



SANYO Semiconductors

DATA SHEET

An ON Semiconductor Company

LV8405V — Bi-CMOS IC 2ch Forward/Reverse Motor Driver

Overview

LV8405T is a 2ch forward/reverse motor driver IC using D-MOS FET for output stage. As MOS circuit is used, it supports the PWM input. Its features are that the on resistance (0.75Ω typ) and current dissipation are low.

It also provides protection functions such as heat protection circuit and reduced voltage detection and is optimal for the motors that need high-current.

Functions

- 2ch forward/reverse motor driver.
- Low power consumption.
- Low-temperature resistance 0.75Ω.
- Built-in low voltage reset and thermal shutdown circuit.
- Four mode function forward/reverse, brake, stop.
- Built-in charge pump.

Specifications

Maximum Ratings at Ta = 25°C, SGND = PGND = 0V

Parameter	Symbol	Conditions	Ratings	Unit
Power supply voltage (for load)	VM max		-0.5 to 16.0	V
Power supply voltage (for control)	VCC max		-0.5 to 6.0	V
Output current	IO max		1.4	A
Output peak current	IO peak	t ≤ 10ms	2.5	A
Input voltage	VIN max		-0.5 to VCC+0.5	V
Allowable power dissipation	Pd max	Mounted on a specified board*	800	mW
Operating temperature	Topr		-20 to +85	°C
Storage temperature	Tstg		-55 to +150	°C

* Specified board : 114.3mm × 76.1mm × 1.6mm, glass epoxy board.

■ Any and all SANYO Semiconductor Co.,Ltd. products described or contained herein are, with regard to "standard application", intended for the use as general electronics equipment (home appliances, AV equipment, communication device, office equipment, industrial equipment etc.). The products mentioned herein shall not be intended for use for any "special application" (medical equipment whose purpose is to sustain life, aerospace instrument, nuclear control device, burning appliances, transportation machine, traffic signal system, safety equipment etc.) that shall require extremely high level of reliability and can directly threaten human lives in case of failure or malfunction of the product or may cause harm to human bodies, nor shall they grant any guarantee thereof. If you should intend to use our products for applications outside the standard applications of our customer who is considering such use and/or outside the scope of our intended standard applications, please consult with us prior to the intended use. If there is no consultation or inquiry before the intended use, our customer shall be solely responsible for the use.

■ Specifications of any and all SANYO Semiconductor Co.,Ltd. products described or contained herein stipulate the performance, characteristics, and functions of the described products in the independent state, and are not guarantees of the performance, characteristics, and functions of the described products as mounted in the customer's products or equipment. To verify symptoms and states that cannot be evaluated in an independent device, the customer should always evaluate and test devices mounted in the customer's products or equipment.

SANYO Semiconductor Co., Ltd.

www.semiconductor-sanyo.com/network

LV8405V

Allowable Operating Conditions at $T_a = 25^\circ\text{C}$, $\text{SGND} = \text{PGND} = 0\text{V}$

Parameter	Symbol	Conditions	Ratings	Unit
Power supply voltage (VM pin)	VM		1.5 to 15.0	V
Power supply voltage (V _{CC} pin)	V _{CC}		2.8 to 5.5	V
Input signal voltage	V _{IN}		0 to V _{CC}	V
Input signal frequency	f max		200	kHz

Electrical Characteristics $T_a = 25^\circ\text{C}$, $V_{CC} = 3.0\text{V}$, $V_M = 6.0\text{V}$, $\text{SGND} = \text{PGND} = 0\text{V}$, unless otherwise specified.

Parameter	Symbol	Conditions	Remarks	Ratings			Unit
				min	typ	max	
Standby load current drain	IMO	$V_{CC} = 0\text{V}$, $V_M = 6\text{V}$	1			1.0	μA
Operating control current drain	IC1	When V _{CC} is applied, with no load	2		0.85	1.2	mA
High-level input voltage	V _{IH}	$2.7 \leq V_{CC} \leq 5.5\text{V}$		$0.6 \times V_{CC}$		V _{CC}	V
Low-level input voltage	V _{IL}	$2.7 \leq V_{CC} \leq 5.5\text{V}$		0		$0.2 \times V_{CC}$	V
High-level input current (IN1, IN2, IN3, IN4)	I _{IH}	IN1, IN2, IN3, IN4 = 3V	3		15	25	μA
Low-level input current (IN1, IN2, IN3, IN4)	I _{IL}	IN1, IN2, IN3, IN4 = 0V	3	-1.0			μA
Pull-down resistance value (IN1-4)	RPD1			100	200	400	k Ω
Charge pump voltage	VG	$V_{CC} + V_M$		8.5	9.0	9.5	V
Output ON resistance 1	RON1	Sum of top and bottom sides ON resistance.	4		0.75	1.2	Ω
Output ON resistance 2	RON2	Sum of top and bottom sides ON resistance. $V_{CC} = 2.8\text{V}$	4		1.0	1.5	Ω
Low-voltage detection voltage	VCS	V _{CC} pin voltage is monitored	5	2.15	2.30	2.45	V
Thermal shutdown temperature	T _{th}	Design guarantee value *	6	150	180	210	$^\circ\text{C}$
Output block	Turn-on time	TPLH	7		0.2	0.4	μS
	Turn-off time	TPHL	7		0.2	0.4	μS

* : Design guarantee value and no measurement is performed.

Remarks

1. Current consumption when output at the VM pin is off.
2. Current consumption at the V_{CC} pin when V_{CC} is 3V and IN1 to IN4 are all 0V (standby mode).
3. Pins IN 1, 2, 3, and 4 are all pulled down.
4. Sum of upper and lower saturation voltages of OUT pin divided by the current.
5. All power transistors are turned off if a low V_{CC} condition is detected.
6. All output transistors are turned off if the thermal protection circuit is activated. They are turned on again as the temperature goes down.
7. Rising time from 10 to 90% and falling time from 90 to 10% are specified.

LV8405V

Package Dimensions

unit : mm (typ)

3178B

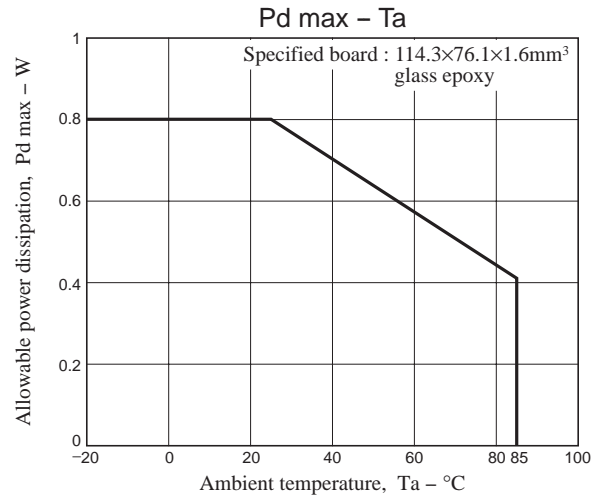
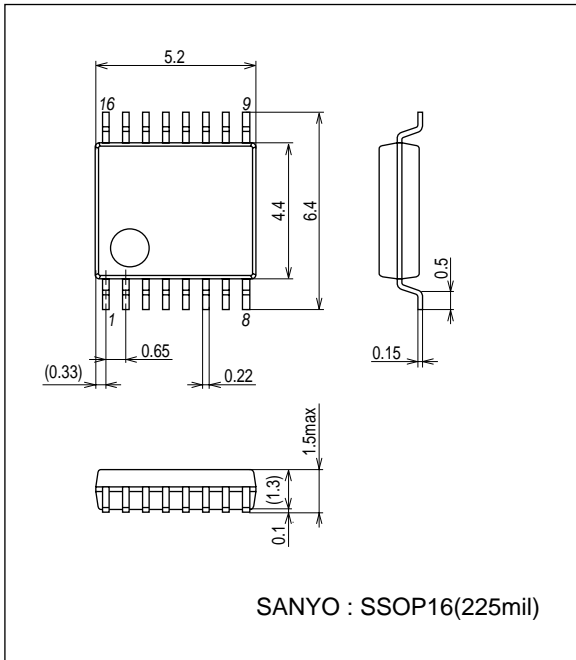

Pin Assignment

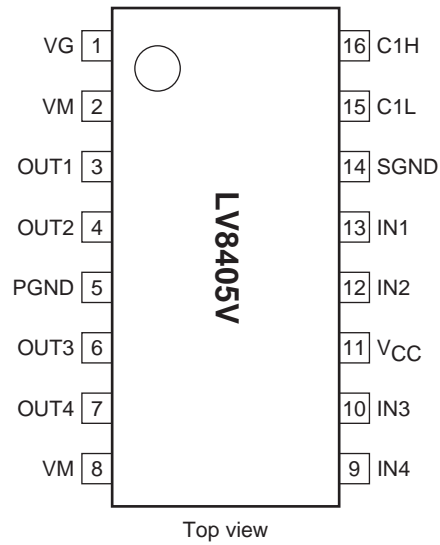

Block Diagram

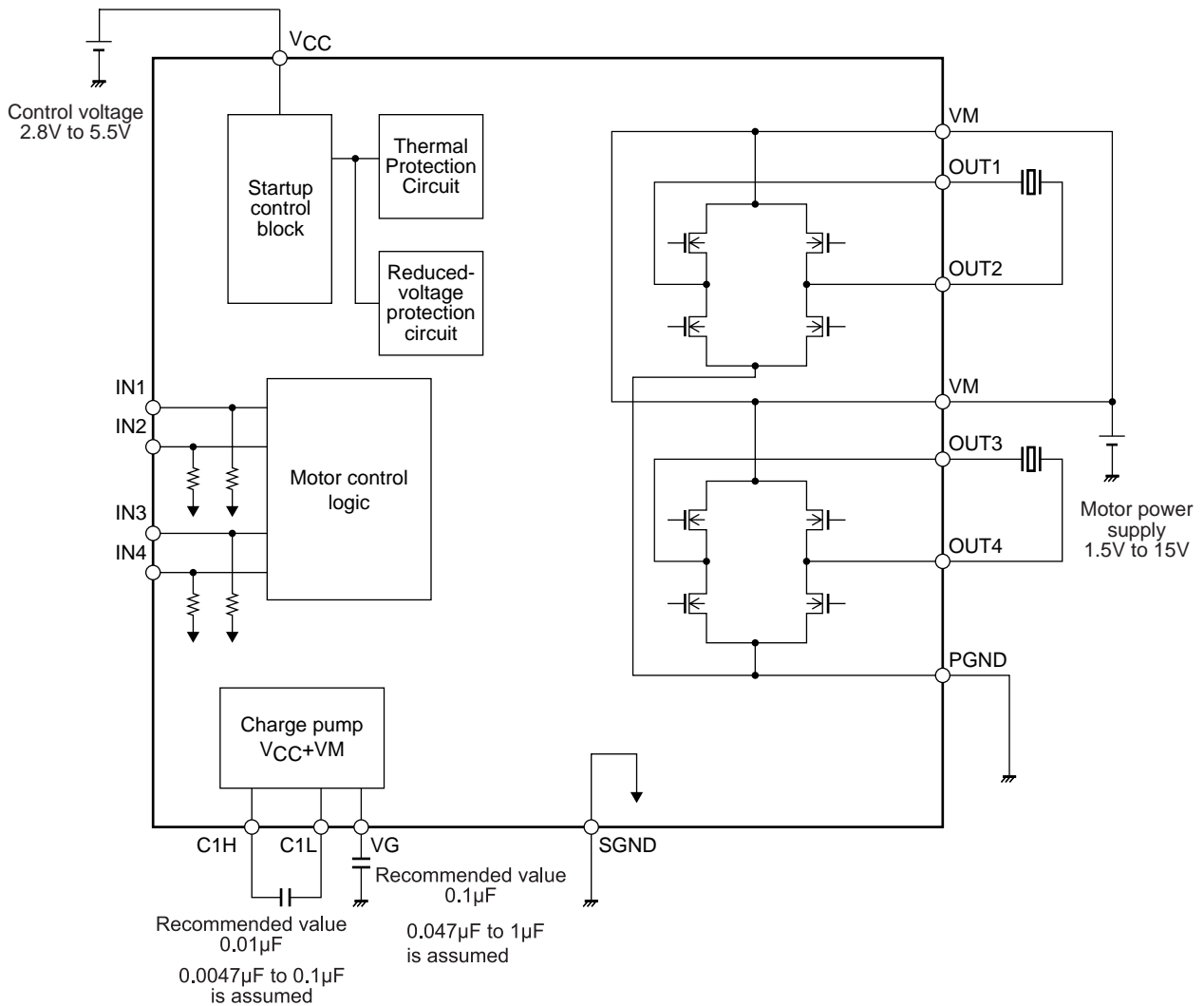

* Connect a kickback absorption capacitor as near as possible to the IC. Coil kickback may cause increase in VM line voltage, and a voltage exceeding the maximum rating may be applied momentarily to the IC, which results in deterioration or damage of the IC

Truth Table

IN1 (IN3)	IN2 (IN4)	OUT1 (OUT3)	OUT2 (OUT4)	Charge pump	Mode
H	H	Z	Z	ON	Standby
H	L	L	H		Reverse
L	H	H	L		Forward
L	L	L	L		Brake

- : denotes a don't care value. Z : High-impedance

- The charge pump is always activated as long as V_{CC} is applied.
- * All power transistors turn off and the motor stops driving when the IC is detected in low voltage or thermal protection mode.

LV8405V

Pin Functions

Pin No.	Pin name	Description	Equivalent circuit
16 1	C1H VG	Step-up capacitor connection pin.	
13 12 10 9	IN1 IN2 IN3 IN4	Driver output switching. (Pull-down resistor incorporated)	
3 4 6 7	OUT1 OUT2 OUT3 OUT4	Driver output.	
2 8	VM	Motor block power supply.	
11	V _{CC}	Logic block power supply.	
14	SGND	Control block ground.	
5	PGND	Driver block ground.	

- SANYO Semiconductor Co.,Ltd. assumes no responsibility for equipment failures that result from using products at values that exceed, even momentarily, rated values (such as maximum ratings, operating condition ranges, or other parameters) listed in products specifications of any and all SANYO Semiconductor Co.,Ltd. products described or contained herein.
- SANYO Semiconductor Co.,Ltd. strives to supply high-quality high-reliability products, however, any and all semiconductor products fail or malfunction with some probability. It is possible that these probabilistic failures or malfunction could give rise to accidents or events that could endanger human lives, trouble that could give rise to smoke or fire, or accidents that could cause damage to other property. When designing equipment, adopt safety measures so that these kinds of accidents or events cannot occur. Such measures include but are not limited to protective circuits and error prevention circuits for safe design, redundant design, and structural design.
- In the event that any or all SANYO Semiconductor Co.,Ltd. products described or contained herein are controlled under any of applicable local export control laws and regulations, such products may require the export license from the authorities concerned in accordance with the above law.
- No part of this publication may be reproduced or transmitted in any form or by any means, electronic or mechanical, including photocopying and recording, or any information storage or retrieval system, or otherwise, without the prior written consent of SANYO Semiconductor Co.,Ltd.
- Any and all information described or contained herein are subject to change without notice due to product/technology improvement, etc. When designing equipment, refer to the "Delivery Specification" for the SANYO Semiconductor Co.,Ltd. product that you intend to use.
- Information (including circuit diagrams and circuit parameters) herein is for example only; it is not guaranteed for volume production.
- Upon using the technical information or products described herein, neither warranty nor license shall be granted with regard to intellectual property rights or any other rights of SANYO Semiconductor Co.,Ltd. or any third party. SANYO Semiconductor Co.,Ltd. shall not be liable for any claim or suits with regard to a third party's intellectual property rights which has resulted from the use of the technical information and products mentioned above.

This catalog provides information as of March, 2010. Specifications and information herein are subject to change without notice.



Компания «ЭлектроПласт» предлагает заключение долгосрочных отношений при поставках импортных электронных компонентов на взаимовыгодных условиях!

Наши преимущества:

- Оперативные поставки широкого спектра электронных компонентов отечественного и импортного производства напрямую от производителей и с крупнейших мировых складов;
- Поставка более 17-ти миллионов наименований электронных компонентов;
- Поставка сложных, дефицитных, либо снятых с производства позиций;
- Оперативные сроки поставки под заказ (от 5 рабочих дней);
- Экспресс доставка в любую точку России;
- Техническая поддержка проекта, помощь в подборе аналогов, поставка прототипов;
- Система менеджмента качества сертифицирована по Международному стандарту ISO 9001;
- Лицензия ФСБ на осуществление работ с использованием сведений, составляющих государственную тайну;
- Поставка специализированных компонентов (Xilinx, Altera, Analog Devices, Intersil, Interpoint, Microsemi, Aeroflex, Peregrine, Syfer, Eurofarad, Texas Instrument, Miteq, Cobham, E2V, MA-COM, Hittite, Mini-Circuits, General Dynamics и др.);

Помимо этого, одним из направлений компании «ЭлектроПласт» является направление «Источники питания». Мы предлагаем Вам помощь Конструкторского отдела:

- Подбор оптимального решения, техническое обоснование при выборе компонента;
- Подбор аналогов;
- Консультации по применению компонента;
- Поставка образцов и прототипов;
- Техническая поддержка проекта;
- Защита от снятия компонента с производства.



Как с нами связаться

Телефон: 8 (812) 309 58 32 (многоканальный)

Факс: 8 (812) 320-02-42

Электронная почта: org@eplast1.ru

Адрес: 198099, г. Санкт-Петербург, ул. Калинина, дом 2, корпус 4, литера А.