

Continuous Rotation Servo (#900-00008)

General Information

The Parallax Continuous Rotation servo is ideal for robotic products that need a geared wheel drive or other projects that require a 360 degree rotation geared motor. The Parallax Continuous Rotation servo output gear shaft is a standard Futaba configuration. The servo can be adjusted with a small Phillips screw driver if the unit becomes out adjustment on its center set point. Servo is custom manufactured for Parallax by Futaba.



Technical Specifications

- > Power 6vdc max
- > Average Speed 60 rpm
 Note: with 5vdc and no torque
- > Weight 45.0 grams/1.59oz
- > Torque 3.40 kg-cm/47oz-in
- > Size mm (L x W x H)
 40.5x20.0x38.0
- > Size in (L x W x H)
 1.60x.79x1.50
- > Manual adjustment port

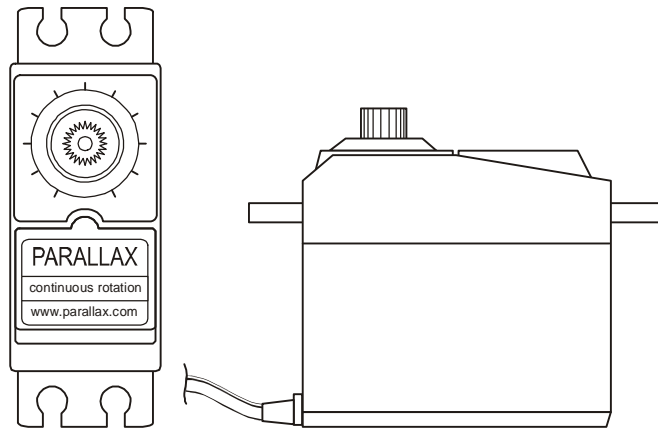

Adjusting the set point for the servo

Using a Parallax screwdriver or an (0x40) size Phillips screw driver. Program the BASIC Stamp® microcontroller you are using with one of the following codes or setup your pulse generator to 1.5 ms at 20ms intervals. Once the pulses are generated and the servo is powered and connected. Insert the Phillips side of your screw driver in to the adjustment port. Once inserted you should be able to turn the internal potentiometer to the left and right. You should see the servo change direction also to the left and right. If not make sure you are making contact with the potentiometer. **Warning: do not press too hard you may do permanent damage to the servo.** To adjust the potentiometer turn to the left/right until the servo stops turning. Be sure to adjust the potentiometer slowly to in sure you do not pass the set point. If you do pass it the servo will change direction.

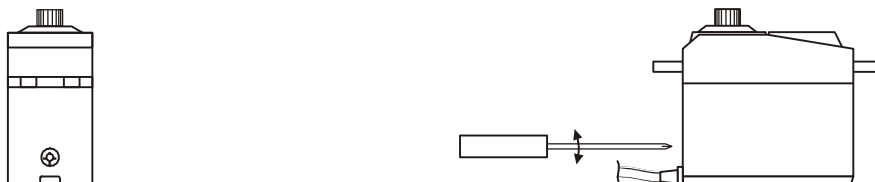

BASIC Stamp 1 code

```
SYMBOL Servo_pin = 0  
  
Start:  
  PULSOUT Servo_pin,150  
  PAUSE 20  
GOTO Start
```

BASIC Stamp 2,2e,2ep code

```
Servo_pin CON 0  
  
Start:  
  PULSOUT Servo_pin,750  
  PAUSE 20  
goto Start
```

BASIC Stamp 2sx,2p24,2p40 code

```
Servo_pin CON 0  
Start:  
  PULSOUT Servo_pin,1875  
  PAUSE 20  
GOTO Start
```

Servo Control from a BASIC Stamp microcontroller

Parallax (www.parallax.com) publishes many circuits and examples to control servos. Most of these examples are available for download from our web site. On www.parallax.com type in "servo" and you'll find example codes below.

Wiring setup

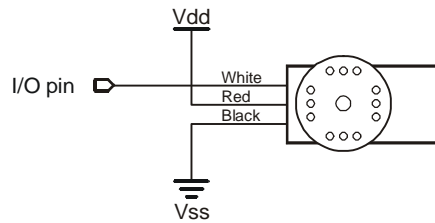

The servo is controlled by pulsing of its signal line. If you are using a Basic Stamp® microcontroller this is done with the 'pulsout' command. Below is PBASIC code that will help you with basic control of a servo. The code below will show center and then rotate the servo to the left and to the right then stop.

Basic Stamp 1 code

```

SYMBOL Temp = W0           'Work space for FOR NEXT
SYMBOL Servo_pin = 0      'I/O pin that is connected to servo

FOR temp = 0 TO 200 '
PULSOUT Servo_pin,150
PAUSE 20
NEXT

FOR temp = 0 TO 200
PULSOUT Servo_pin,180
PAUSE 20
NEXT

FOR temp = 0 TO 200
PULSOUT Servo_pin,120
PAUSE 20
NEXT
Stop

```

BASIC Stamp 2, 2e,2pe code

```

Temp      VAR      Word  'Work space for FOR NEXT
Servo_pin CON      0     'I/O pin that is connected to servo

FOR temp = 0 TO 200
PULSOUT servo_pin,750
PAUSE 20
NEXT

FOR temp = 0 TO 200
PULSOUT servo_pin,900
PAUSE 20
NEXT

FOR temp = 0 TO 200
PULSOUT servo_pin,600
PAUSE 20
NEXT
STOP

```

BASIC Stamp 2sx,2p24/40 code

```

Temp      VAR      Word  'Work space for FOR NEXT
Servo_pin CON      0     'I/O pin that is connected to servo

for temp = 0 to 200
pulsout Servo_pin,1875
pause 20
next

for temp = 0 to 200
pulsout Servo_pin,2250
pause 20
next

for temp = 0 to 200
pulsout Servo_pin,1500
pause 20
next
STOP

```



Компания «ЭлектроПласт» предлагает заключение долгосрочных отношений при поставках импортных электронных компонентов на взаимовыгодных условиях!

Наши преимущества:

- Оперативные поставки широкого спектра электронных компонентов отечественного и импортного производства напрямую от производителей и с крупнейших мировых складов;
- Поставка более 17-ти миллионов наименований электронных компонентов;
- Поставка сложных, дефицитных, либо снятых с производства позиций;
- Оперативные сроки поставки под заказ (от 5 рабочих дней);
- Экспресс доставка в любую точку России;
- Техническая поддержка проекта, помощь в подборе аналогов, поставка прототипов;
- Система менеджмента качества сертифицирована по Международному стандарту ISO 9001;
- Лицензия ФСБ на осуществление работ с использованием сведений, составляющих государственную тайну;
- Поставка специализированных компонентов (Xilinx, Altera, Analog Devices, Intersil, Interpoint, Microsemi, Aeroflex, Peregrine, Syfer, Eurofarad, Texas Instrument, Miteq, Cobham, E2V, MA-COM, Hittite, Mini-Circuits, General Dynamics и др.);

Помимо этого, одним из направлений компании «ЭлектроПласт» является направление «Источники питания». Мы предлагаем Вам помощь Конструкторского отдела:

- Подбор оптимального решения, техническое обоснование при выборе компонента;
- Подбор аналогов;
- Консультации по применению компонента;
- Поставка образцов и прототипов;
- Техническая поддержка проекта;
- Защита от снятия компонента с производства.



Как с нами связаться

Телефон: 8 (812) 309 58 32 (многоканальный)

Факс: 8 (812) 320-02-42

Электронная почта: org@eplast1.ru

Адрес: 198099, г. Санкт-Петербург, ул. Калинина, дом 2, корпус 4, литера А.