

# ABP SERIES

32305128  
Issue F

## Basic Board Mount Pressure Sensors

High Accuracy, Compensated/Amplified  
60 mbar to 10 bar | 6 kPa to 1 MPa | 1 psi to 150 psi  
Digital or Analog Output, Liquid Media Capable

### DESCRIPTION

The ABP Series are piezoresistive silicon pressure sensors offering a ratiometric analog or digital output for reading pressure over the specified full scale pressure span and temperature range. They are calibrated and temperature compensated for sensor offset, sensitivity, temperature effects and accuracy errors (which include non-linearity, repeatability and hysteresis) using an on-board Application Specific Integrated Circuit (ASIC). Calibrated output values for pressure are updated at approximately 1 kHz for analog and 2 kHz for digital. All products are designed and manufactured according to ISO 9001 standards.

- Dry gases option: The input port is limited to non-corrosive, non-ionic media (e.g., dry air, gases) and should not be exposed to condensation. The gases are limited to media compatible with high temperature polyamide, silicone, alumina ceramic, silicon, gold, and glass.
- Liquid media option: Includes an additional silicone-based gel coating to protect the electronics under port P1, which enables use with non-corrosive liquids (e.g. water and saline) and in applications where condensation can occur. Since port P2 is designed for use with non-corrosive liquids, this option is often suitable for wet-wet differential sensing.

### DIFFERENTIATION

- Enhanced accuracy helps the design engineer fully understand the error in measurement.
- Wide supply voltage range offers design flexibility.
- Power consumption when utilizing sleep mode option allows for use in battery-powered applications.

### VALUE TO CUSTOMERS

- Simplifies design-in: Small size saves room on the PC board (PCB), or simplifies design in smaller and lower power devices. Meets Moisture Sensitivity Level 1 requirements, which allows for unlimited shelf life when stored at <30 °C/85 %RH and, under most storage conditions, allows for PCB soldering without any material concern about solder joint quality due

to aging of the sensor terminals, which minimizes the concern about aging of the terminals prior PCB assembly. Pressure choices allow engineers to select range required for their application. Leadless SMT, SMT, and DIP package options.

- Cost-effective: Small size helps engineers reduce design and manufacturing costs while maintaining enhanced performance and reliability of the systems they design.
- Accurate: Total Error Band (TEB) and wide pressure range enable engineers to optimize system performance by improving resolution and system accuracy. Optional internal diagnostics validate that the sensor readings are correct.
- Flexible: Supply voltage range, variety of pressure units, types, and ranges, output options, and wide operating temperature range simplify use in the application.
- Versatile: Wet-media compatibility, sleep mode, and temperature output options make the sensor a versatile choice for Internet of Things applications.
- Honeywell Brand: Utilize proprietary Honeywell technology, and are protected by multiple global patents.

### POTENTIAL APPLICATIONS

- **Medical:** CPAP, blood analysis, blood pressure monitoring, breast pumps, drug dosing, hospital beds, massage machines, oxygen concentrators, patient monitoring, sleep apnea equipment, urine analyzers, ventilators/portable ventilators, and wound therapy
- **Industrial:** Air brakes, HVAC/transmitters, life sciences, material handling, pneumatic control and regulation, process gas monitoring, and valve positioning/positioners
- **Commercial:** Air beds, coffee makers, and washing machines



### FEATURES

- Measures gage and differential pressures
- Total Error Band (see Figure 1):  $\pm 1.5\%$  FSS
- Liquid media option: Allows for wet/wet operation on dual ported devices
- Industry-leading long-term stability:  $\pm 0.25\%$  FSS
- Industry-leading accuracy:  $\pm 0.25\%$  FSS BFSL
- Wide pressure range: 60 mbar to 10 bar | 6 kPa to 1 MPa | 1 psi to 150 psi
- As small as 8 mm x 7 mm
- High burst pressures (see Table 7)
- Calibrated over temperature range of 0°C to 50°C [32°F to 122°F]
- Operates from a single power supply of either 3.3 Vdc or 5.0 Vdc
- Output: Ratiometric analog or I<sup>2</sup>C- or SPI-compatible 12-bit digital
- Power consumption: 2 uA typical when utilizing sleep mode option
- Meet IPC/JEDEC J-STD-020D.1 Moisture Sensitivity Level 1 requirements
- REACH and RoHS compliant
- Options: Internal diagnostic function, liquid media, sleep mode, temperature output



### PORTFOLIO

Honeywell offers a variety of board mount pressure sensors for potential use in medical and industrial applications. To view the entire product portfolio, [click here](#).

**Honeywell**

## Basic Board Mount Pressure Sensors, ABP Series

**FIGURE 1. TOTAL ERROR BAND**

Total Error Band (TEB) is a single specification that includes all possible sources of error. TEB should not be confused with accuracy, which is actually a component of TEB. TEB is the worst error that the sensor could experience. The TEB specification on a datasheet may be confusing. Honeywell uses the TEB specification in its datasheet because it is the most comprehensive measurement of a sensor's true accuracy. Honeywell also provides the accuracy specification in order to provide a common comparison with competitors' literature that does not use the TEB specification. Many competitors do not use TEB—they simply specify the accuracy of their device. Their accuracy specification, however, may exclude certain parameters. On their datasheet, the errors are listed individually. When combined, the total error (or what would be TEB) can be significant.



**TABLE 1. ABSOLUTE MAXIMUM RATINGS<sup>1</sup>**

CHARACTERISTIC	MIN.	MAX.	UNIT
Supply voltage ( $V_{\text{supply}}$ )	-0.3	6.0	Vdc
Voltage on any pin	-0.3	$V_{\text{supply}} + 0.3$	V
Digital interface clock frequency:			
I <sup>2</sup> C	100	400	kHz
SPI	50	800	
ESD susceptibility (human body model)	2	—	kV
Storage temperature	-40 [-40]	85 [185]	°C [°F]
Soldering time and temperature:			
lead solder temperature (DIP)		4 s max. at 250°C [482°F]	
peak reflow temperature (Leadless SMT, SMT)		15 s max. at 250°C [482°F]	

<sup>1</sup>Absolute maximum ratings are the extreme limits the device will withstand without damage.

**TABLE 2. ENVIRONMENTAL SPECIFICATIONS**

CHARACTERISTIC	PARAMETER
Humidity:	
all external surfaces	0 %RH to 95 %RH, non-condensing
internal surfaces of Liquid Media Option (T, V, F, G)	0 %RH to 100 %RH, condensing
internal surfaces of Dry Gases Option (N, D)	0 %RH to 95 %RH, non-condensing
Vibration	15 g, 10 Hz to 2 kHz
Shock	100 g, 6 ms duration
Life <sup>1</sup>	1 million pressure cycles minimum
Solder reflow	J-STD-020-D.1 Moisture Sensitivity Level 1 (unlimited shelf life when stored at $\leq 30^\circ\text{C}/85\% \text{RH}$ )

<sup>1</sup>Life may vary depending on specific application in which the sensor is used.

**TABLE 3. WETTED MATERIALS<sup>1</sup>**

COMPONENT	PRESSURE PORT 1 (P1)		PRESSURE PORT 2 (P2)
	DRY GAS OPTION	LIQUID MEDIA OPTION	
Ports and covers	high temperature polyamide		
Substrate	alumina ceramic	—	alumina ceramic
Adhesives	epoxy, silicone	epoxy, silicone gel	epoxy, silicone
Electronic components	silicon, glass, solder, gold, aluminum	304 SST	silicon

<sup>1</sup>Contact Honeywell Customer Service for detailed material information.

**TABLE 4. SENSOR PRESSURE TYPES**

PRESSURE TYPE	DESCRIPTION
Gage	Output is proportional to the difference between applied pressure and atmospheric (ambient) pressure.
Differential	Output is proportional to the difference between the pressures applied to each port (Port 1 – Port 2).

## Basic Board Mount Pressure Sensors, ABP Series

**TABLE 5. OPERATING SPECIFICATIONS**

CHARACTERISTIC	ANALOG			DIGITAL			UNIT
	MIN.	TYP.	MAX.	MIN.	TYP.	MAX.	
Supply voltage ( $V_{\text{supply}}$ ): <sup>1,2,3</sup> 3.3 Vdc 5.0 Vdc	3.0 4.75	3.3 5.0	3.6 5.25	3.0 4.75	3.3 5.0	3.6 5.25	Vdc
Supply current: 3.3 Vdc 5.0 Vdc sleep mode option	— — —	2.1 2.7 —	2.8 3.8 —	— — —	3.1 3.7 1	3.9 4.6 10	mA mA uA
Operating temperature range <sup>4</sup>	-40 [-40]	—	85 [185]	-40 [-40]	—	85 [185]	°C [°F]
Compensated temperature range <sup>5</sup>	0 [-32]	—	50 [122]	0 [-32]	—	50 [122]	°C [°F]
Temperature output option <sup>6</sup>	—	—	—	—	±4	—	°C
Startup time (power up to data ready)	—	—	5	—	—	3	ms
Response time	—	1	—	—	0.46	—	ms
Clipping limit: upper lower	— 2.5	— —	97.5 —	— —	— —	— —	%Vsupply
I <sup>2</sup> C/SPI voltage level: low high	— —	— —	— —	— 80	— —	20 —	%Vsupply
Pull up on SDA/MISO, SCL/SCLK, SS	—	—	—	1	—	—	kOhm
Total Error Band <sup>7</sup>	—	—	±1.5	—	—	±1.5	%FSS <sup>8</sup>
Accuracy <sup>9</sup>	—	—	±0.25	—	—	±0.25	%FSS BFSL
Long term stability (1000 hr, 25°C [77°F])	—	—	±0.25	—	—	±0.25	%FSS
Output resolution	0.03 —	— —	— —	— 12	— —	— —	%FSS bits

<sup>1</sup>Sensors are either 3.3 Vdc or 5.0 Vdc based on the catalog listing selected.

<sup>2</sup>Ratiometricity of the sensor (the ability of the device output to scale to the supply voltage) is achieved within the specified operating voltage.

<sup>3</sup>The sensor is not reverse polarity protected. Incorrect application of supply voltage or ground to the wrong pin may cause electrical failure.

<sup>4</sup>Operating temperature range: The temperature range over which the sensor will produce an output proportional to pressure.

<sup>5</sup>Compensated temperature range: The temperature range over which the sensor will produce an output proportional to pressure within the specified performance limits.

<sup>6</sup>Temperature output option: Typical temperature output error over the compensated temperature range of 0°C to 50°C. Operation in Sleep Mode may affect temperature output error depending on duty cycle.

<sup>7</sup>Total Error Band: The maximum deviation from the ideal transfer function over the entire compensated temperature and pressure range. Includes all errors due to offset, full scale span, pressure non-linearity, pressure hysteresis, repeatability, thermal effect on offset, thermal effect on span, and thermal hysteresis.

<sup>8</sup>Full Scale Span (FSS): The algebraic difference between the output signal measured at the maximum (Pmax.) and minimum (Pmin.) limits of the pressure range. (See Figure 2.)

<sup>9</sup>Accuracy: The maximum deviation in output from a Best Fit Straight Line (BFSL) fitted to the output measured over the pressure range at 25°C [77°F]. Includes all errors due to pressure non-linearity, pressure hysteresis, and non-repeatability.

**TABLE 6. SENSOR OUTPUT AT SIGNIFICANT PERCENTAGES (DIGITAL VERSIONS ONLY)**

% OUTPUT	DIGITAL COUNTS	
	DECIMAL	HEX
0	0	0x0000
10	1638	0x0666
50	8192	0x2000
90	14746	0x399A
100	16383	0x3FFF

# Basic Board Mount Pressure Sensors, ABP Series

FIGURE 2. TRANSFER FUNCTION LIMITS<sup>1</sup>

## Analog Versions



$$\text{Output (V)} = \frac{0.8 \times V_{\text{supply}}}{P_{\text{max.}} - P_{\text{min.}}} \times (\text{Pressure}_{\text{applied}} - P_{\text{min.}}) + 0.10 \times V_{\text{supply}}$$

## Digital Versions



$$\text{Output (\% of } 2^{14} \text{ counts)} = \frac{80\%}{P_{\text{max.}} - P_{\text{min.}}} \times (\text{Pressure}_{\text{applied}} - P_{\text{min.}}) + 10\%$$

<sup>1</sup>Transfer Function "A" is shown. See Figure 3 for other available transfer functions.

# Basic Board Mount Pressure Sensors, ABP Series

FIGURE 3. NOMENCLATURE AND ORDER GUIDE

For example, **ABPDNNN150PGAA3** defines an ABP Series Amplified Basic Pressure Sensor, DIP package, NN pressure port, dry gases only, no diagnostics, 150 psi gage pressure range, analog output type, 10% to 90% of Vsupply (analog), transfer function, no temperature output, no sleep mode, 3.3 Vdc supply voltage.

**Product Series**  
**ABP** Amplified Basic

**Package**  
**D** DIP (Dual Inline Pin)  
**M** SMT (Surface Mount Technology)  
**L** Leadless SMT

**Pressure Port**

DIP	SMT	Leadless SMT
<b>NN</b> No port 	<b>NN</b> No port 	<b>NN</b> No port 
<b>AN</b> Single axial barbed port 	<b>AN</b> Single axial barbed port 	<b>AN</b> Single axial barbed port 
<b>LN</b> Single axial barbless port 	<b>LN</b> Single axial barbless port 	<b>LN</b> Single axial barbless port 
<b>JN</b> Single radial barbless port 	<b>JN</b> Single radial barbless port 	—
<b>JJ</b> Dual radial barbless ports, same side 	<b>JJ</b> Dual radial barbless ports, same side 	—
<b>RN</b> Single radial barbed port 	<b>RN</b> Single radial barbed port 	—
<b>RR</b> Dual radial barbed ports, same side 	<b>RR</b> Dual radial barbed ports, same side 	—

**Supply Voltage**  
**3** 3.3 Vdc  
**5** 5.0 Vdc

**Transfer Function<sup>3</sup>**  
**A** 10% to 90% of Vsupply (analog), 2<sup>14</sup> counts (digital) no temperature output, no sleep mode  
**D** 10% to 90% of 2<sup>14</sup> counts (digital only) temperature output enabled, sleep mode enabled  
**S** 10% to 90% of 2<sup>14</sup> counts (digital only) no temperature output, sleep mode enabled  
**T** 10% to 90% of 2<sup>14</sup> counts (digital only) temperature output enabled, no sleep mode

**Output Type**  
**A** Analog **3** I<sup>2</sup>C, Address 0x38  
**S** SPI **4** I<sup>2</sup>C, Address 0x48  
**0** I<sup>2</sup>C, Address 0x08 **5** I<sup>2</sup>C, Address 0x58  
**1** I<sup>2</sup>C, Address 0x18 **6** I<sup>2</sup>C, Address 0x68  
**2** I<sup>2</sup>C, Address 0x28 **7** I<sup>2</sup>C, Address 0x78

**Pressure Range<sup>1,2</sup>**

60 mbar to 10 bar Differential		6 kPa to 1 MPa Differential		1 psi to 150 psi Differential	
<b>060MD</b>	±60 mbar	<b>006KD</b>	±6 kPa	<b>001PD</b>	±1 psi
<b>100MD</b>	±100 mbar	<b>010KD</b>	±10 kPa	<b>005PD</b>	±5 psi
<b>160MD</b>	±160 mbar	<b>016KD</b>	±16 kPa	<b>015PD</b>	±15 psi
<b>250MD</b>	±250 mbar	<b>025KD</b>	±25 kPa	<b>030PD</b>	±30 psi
<b>400MD</b>	±400 mbar	<b>040KD</b>	±40 kPa	<b>060PD</b>	±60 psi
<b>600MD</b>	±600 mbar	<b>060KD</b>	±60 kPa		
<b>001BD</b>	±1 bar	<b>100KD</b>	±100 kPa		
<b>1.6BD</b>	±1.6 bar	<b>160KD</b>	±160 kPa		
<b>2.5BD</b>	±2.5 bar	<b>250KD</b>	±250 kPa		
<b>004BD</b>	±4 bar	<b>400KD</b>	±400 kPa		

Gage		Gage		Gage	
<b>060MG</b>	0 mbar to 60 mbar	<b>006KG</b>	0 kPa to 6 kPa	<b>001PG</b>	0 psi to 1 psi
<b>100MG</b>	0 mbar to 100 mbar	<b>010KG</b>	0 kPa to 10 kPa	<b>005PG</b>	0 psi to 5 psi
<b>160MG</b>	0 mbar to 160 mbar	<b>016KG</b>	0 kPa to 16 kPa	<b>015PG</b>	0 psi to 15 psi
<b>250MG</b>	0 mbar to 250 mbar	<b>025KG</b>	0 kPa to 25 kPa	<b>030PG</b>	0 psi to 30 psi
<b>400MG</b>	0 bar to 400 mbar	<b>040KG</b>	0 kPa to 40 kPa	<b>060PG</b>	0 psi to 60 psi
<b>600MG</b>	0 bar to 600 mbar	<b>060KG</b>	0 kPa to 60 kPa	<b>100PG</b>	0 psi to 100 psi
<b>001BG</b>	0 bar to 1 bar	<b>100KG</b>	0 kPa to 100 kPa	<b>150PG</b>	0 psi to 150 psi
<b>1.6BG</b>	0 bar to 1.6 bar	<b>160KG</b>	0 kPa to 160 kPa		
<b>2.5BG</b>	0 bar to 2.5 bar	<b>250KG</b>	0 kPa to 250 kPa		
<b>004BG</b>	0 bar to 4 bar	<b>400KG</b>	0 kPa to 400 kPa		
<b>006BG</b>	0 bar to 6 bar	<b>600KG</b>	0 kPa to 600 kPa		
<b>010BG</b>	0 bar to 10 bar	<b>001GG</b>	0 kPa to 1 MPa		

**Option**  
**N** Dry gases only, no diagnostics  
**D** Dry gases only, diagnostics on  
**T** Liquid media, silicone gel, no diagnostics  
**V** Liquid media, silicone gel, diagnostics on  
**F** Liquid media, flourosilicone gel, diagnostics on  
**G** Liquid media, flourosilicone gel, no diagnostics

<sup>1</sup> Custom pressure ranges are available. Contact Honeywell Customer Service for more information.

<sup>2</sup> See the explanation of sensor pressure types in Table 4.

<sup>3</sup> The transfer function limits define the output of the sensor at a given pressure input. By specifying Pmin. and Pmax., the output at Pmin. and Pmax., the complete transfer function of the sensor is defined. See the graphical representations of the transfer function in Figure 2.

# Basic Board Mount Pressure Sensors, ABP Series

**TABLE 7. PRESSURE RANGE SPECIFICATIONS**

PRESSURE RANGE (SEE FIGURE 3.)	PRESSURE RANGE		UNIT	OVERPRESSURE <sup>1</sup>		BURST PRESSURE <sup>2</sup>		COMMON MODE PRESSURE <sup>3</sup>
	PMIN.	PMAX.		PORT 1 (P1)	PORT 2 (P2)	PORT 1 (P1)	PORT 2 (P2)	
<b>1 psi to 150 psi</b>								
<b>Differential</b>								
060MD	-60	60	mbar	2000	850	3500	1000	10000
100MD	-100	100	mbar	4000	1400	7000	2500	10000
160MD	-160	160	mbar	4000	1400	7000	2500	10000
250MD	-250	250	mbar	10000	2000	19000	4000	10000
400MD	-400	400	mbar	10000	2000	19000	4000	10000
600MD	-600	600	mbar	17000	2000	19000	4000	10000
001BD	-1	1	bar	17	4	19	8	17
1.6BD	-1.6	1.6	bar	17	8	19	16	17
2.5BD	-2.5	2.5	bar	17	8	19	16	17
004BD	-4.0	4.0	bar	17	16	19	19	17
<b>Gage</b>								
060MG	0	60	mbar	2000	—	3500	—	5500
100MG	0	100	mbar	2000	—	3500	—	10000
160MG	0	160	mbar	2000	—	3500	—	10000
250MG	0	250	mbar	4000	—	7000	—	10000
400MG	0	400	mbar	10000	—	19000	—	10000
600MG	0	600	mbar	10000	—	19000	—	10000
001BG	0	1	bar	17	—	19	—	17
1.6BG	0	1.6	bar	17	—	19	—	17
2.5BG	0	2.5	bar	17	—	19	—	17
004BG	0	4	bar	17	—	19	—	17
006BG	0	6	bar	17	—	19	—	17
010BG	0	10	bar	17	—	19	—	17
<b>6 kPa to 1 MPa</b>								
<b>Differential</b>								
006KD	-6	6	kPa	200	85	350	100	1000
010KD	-10	10	kPa	400	140	700	250	1000
016KD	-16	16	kPa	400	140	700	250	1000
025KD	-25	25	kPa	1000	200	1900	400	1000
040KD	-40	40	kPa	1000	200	1900	400	1000
060KD	-60	60	kPa	1700	200	1900	400	1000
100KD	-100	100	kPa	1700	400	1900	800	1700
160KD	-160	160	kPa	1700	800	1900	1600	1700
250KD	-250	250	kPa	1700	800	1900	1600	1700
400KD	-400	400	kPa	1700	1600	1900	1900	1700
<b>Gage</b>								
006KG	0	6	kPa	200	—	350	—	550
010KG	0	10	kPa	200	—	350	—	1000
016KG	0	16	kPa	200	—	350	—	1000
025KG	0	25	kPa	400	—	700	—	1000
040KG	0	40	kPa	1000	—	1900	—	1000
060KG	0	60	kPa	1000	—	1900	—	1000
100KG	0	100	kPa	1700	—	1900	—	1700
160KG	0	160	kPa	1700	—	1900	—	1700
250KG	0	250	kPa	1700	—	1900	—	1700
400KG	0	400	kPa	1700	—	1900	—	1700
600KG	0	600	kPa	1700	—	1900	—	1700
001GG	0	1	MPa	1.7	—	1.9	—	1.7

# Basic Board Mount Pressure Sensors, ABP Series

**TABLE 7. PRESSURE RANGE SPECIFICATIONS (CONTINUED)**

PRESSURE RANGE (SEE FIGURE 3.)	PRESSURE RANGE		UNIT	OVERPRESSURE <sup>1</sup>		BURST PRESSURE <sup>2</sup>		COMMON MODE PRESSURE <sup>3</sup>
	PMIN.	PMAX.		Port 1 (P1)	Port 2 (P2)	Port 1 (P1)	Port 2 (P2)	
<b>1 psi to 150 psi</b>								
<b>Differential</b>								
001PD	-1	1	psi	30	10	50	15	150
005PD	-5	5	psi	150	30	275	40	150
015PD	-15	15	psi	250	60	275	120	250
030PD	-30	30	psi	250	120	275	240	250
060PD	-60	60	psi	250	250	275	275	250
<b>Gage</b>								
001PG	0	1	psi	30	—	50	—	150
005PG	0	5	psi	150	—	275	—	150
015PG	0	15	psi	250	—	275	—	250
030PG	0	30	psi	250	—	275	—	250
060PG	0	60	psi	250	—	275	—	250
100PG	0	100	psi	250	—	275	—	250
150PG	0	150	psi	250	—	275	—	250

<sup>1</sup>Overpressure: The maximum pressure which may safely be applied to the product for it to remain in specification once pressure is returned to the operating pressure range. Exposure to higher pressures may cause permanent damage to the product. Unless otherwise specified this applies to all available pressure ports at any temperature with the operating temperature range.

<sup>2</sup>Burst pressure: The maximum pressure that may be applied to the specified port (P1 or P2) of the product without causing escape of pressure media. Product should not be expected to function after exposure to any pressure beyond the burst pressure.

<sup>3</sup>Common mode pressure: The maximum pressure that can be applied simultaneously to both ports of a differential pressure sensor without causing changes in specified performance.

**FIGURE 4. RECOMMENDED FILTER CAP**

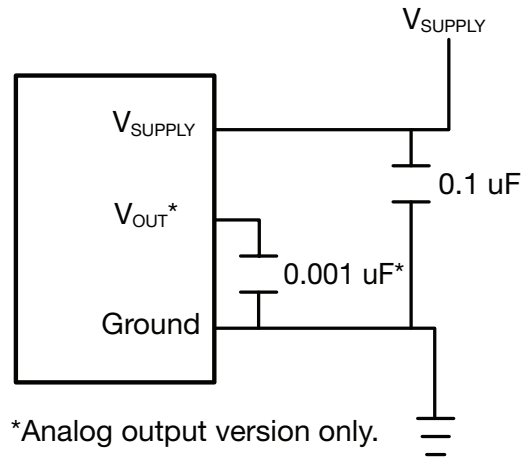

# Basic Board Mount Pressure Sensors, ABP Series

FIGURE 5. DIP PACKAGE DIMENSIONAL DRAWINGS (FOR REFERENCE ONLY: MM [IN.] )

DIP NN: No port



DIP AN: Single axial barbed port

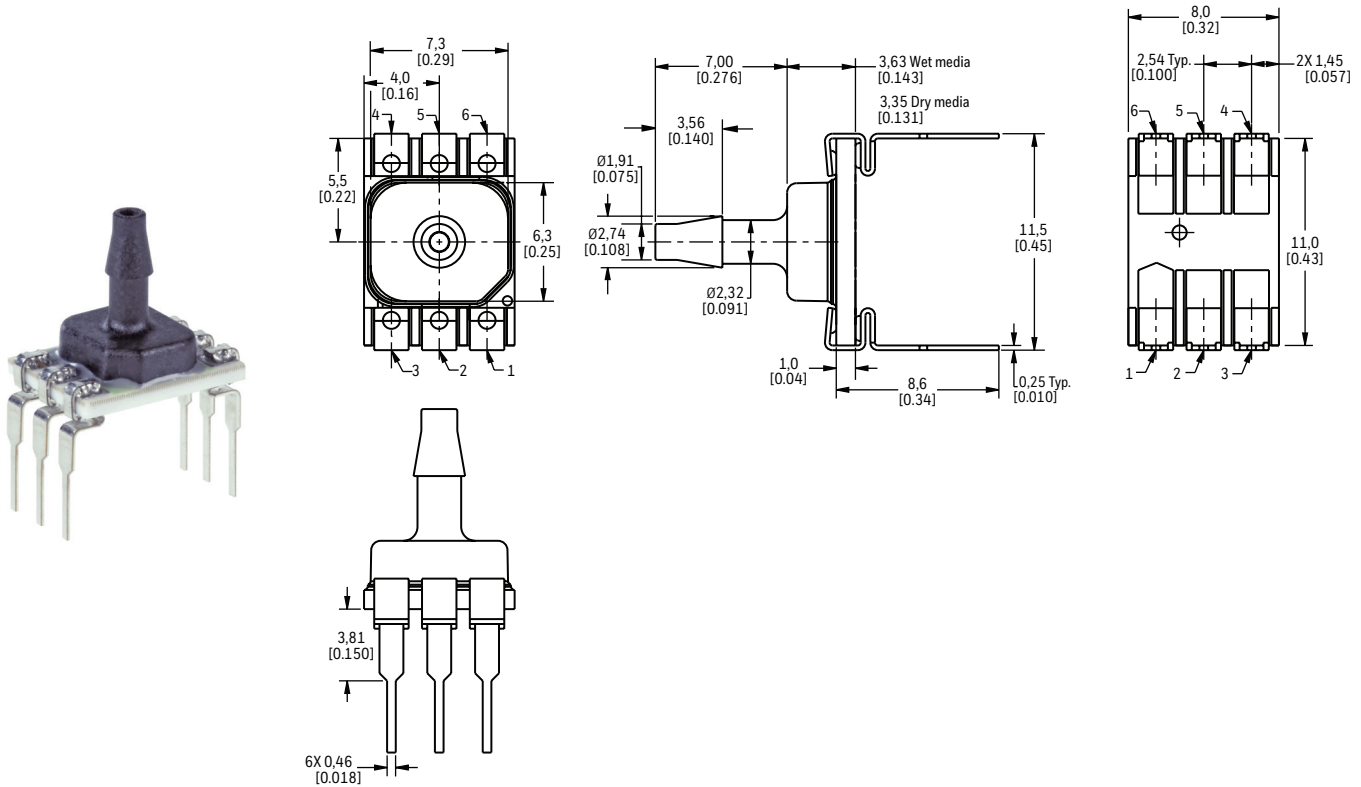



# Basic Board Mount Pressure Sensors, ABP Series

FIGURE 5. DIP PACKAGE DIMENSIONAL DRAWINGS (CONTINUED)

**DIP LN:** Single axial barless port

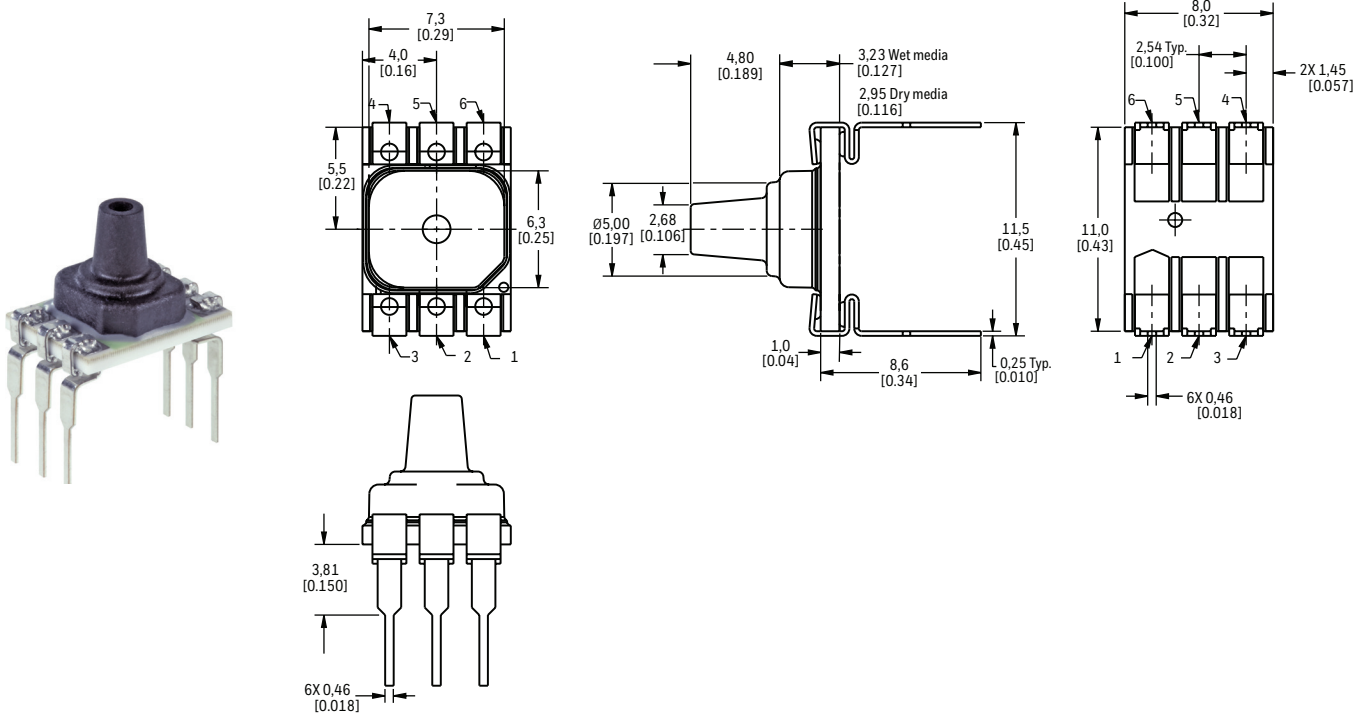

**DIP JN:** Single radial barless port



# Basic Board Mount Pressure Sensors, ABP Series

**FIGURE 5. DIP PACKAGE DIMENSIONAL DRAWINGS (CONTINUED)**

**DIP JJ:** Dual radial barbless ports, same side



**DIP RN:** Single radial barbed port



**DIP RR:** Dual radial barbed ports, same side



# Basic Board Mount Pressure Sensors, ABP Series

**FIGURE 6. SMT PACKAGE DIMENSIONAL DRAWINGS (FOR REFERENCE ONLY: MM [IN.] )**

**SMT NN:** No port



**SMT AN:** Single axial barbed port



**SMT LN:** Single axial barbless port



**SMT JN:** Single radial barbless port



# Basic Board Mount Pressure Sensors, ABP Series

FIGURE 6. SMT PACKAGE DIMENSIONAL DRAWINGS (CONTINUED)

**SMT JJ:** Dual radial barless ports, same side

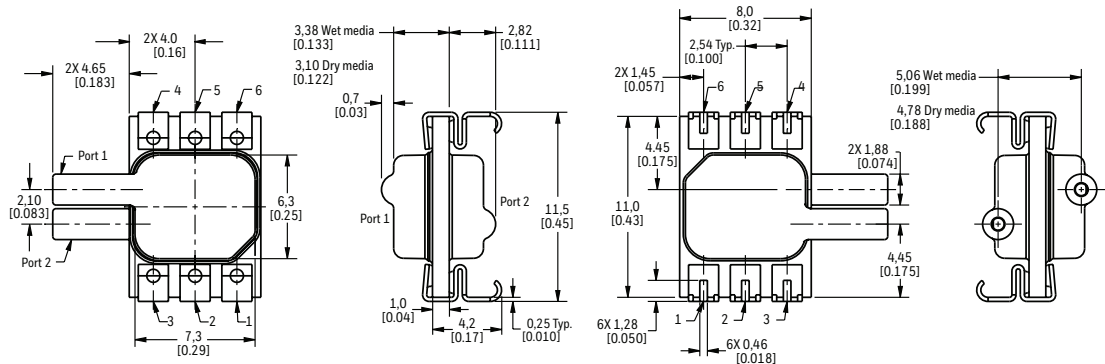
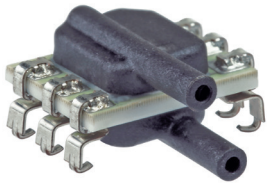

**SMT RN:** Single radial barbed port

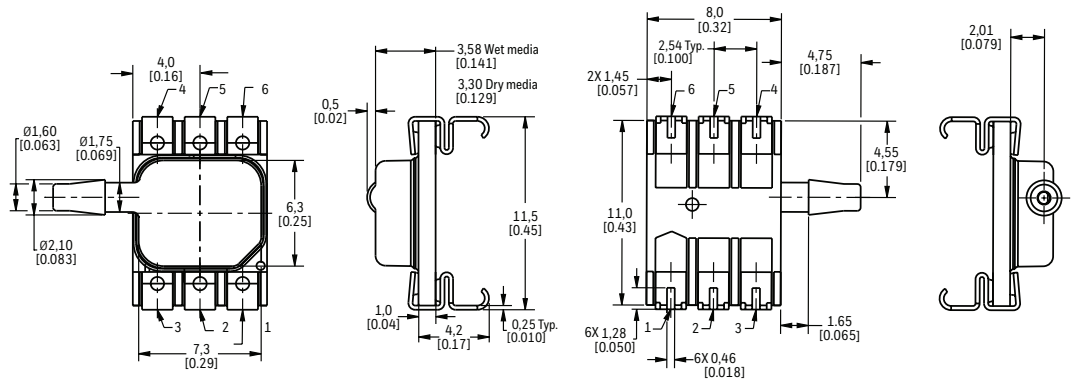
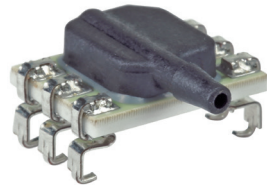

**SMT RR:** Dual radial barbed ports, both sides

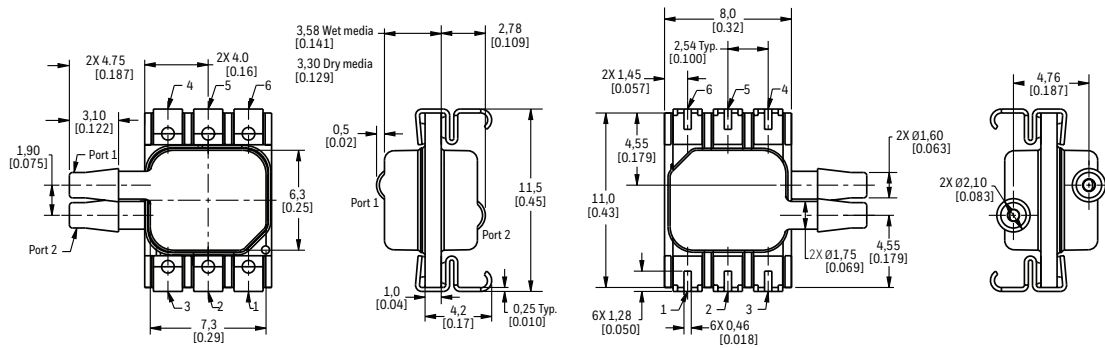
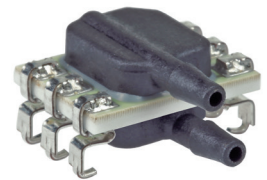

# Basic Board Mount Pressure Sensors, ABP Series

FIGURE 7. LEADLESS SMT PACKAGE DIMENSIONAL DRAWINGS (FOR REFERENCE ONLY: MM [IN.]

Leadless SMT NN: No port



Leadless SMT AN: Single axial barbed port



Leadless SMT LN: Single axial barbless port



TABLE 8. PINOUTS						
OUTPUT TYPE	PIN 1	PIN 2	PIN 3	PIN 4	PIN 5	PIN 6
I <sup>2</sup> C	GND	V <sub>supply</sub>	INT	NC	SDA	SCL
SPI	GND	V <sub>supply</sub>	SS	NC	MISO	SCLK
analog	GND	NC	V <sub>out</sub>	NC	NC	V <sub>supply</sub>

FIGURE 8. RECOMMENDED PCB LAYOUTS



## ADDITIONAL MATERIALS

The following associated literature is available at [sensing.honeywell.com](http://sensing.honeywell.com):

- Product range guide
- Installation instructions
- Application note

## WARRANTY/REMEDY

Honeywell warrants goods of its manufacture as being free of defective materials and faulty workmanship during the applicable warranty period. Honeywell's standard product warranty applies unless agreed to otherwise by Honeywell in writing; please refer to your order acknowledgment or consult your local sales office for specific warranty details. If warranted goods are returned to Honeywell during the period of coverage, Honeywell will repair or replace, at its option, without charge those items that Honeywell, in its sole discretion, finds defective.

**The foregoing is buyer's sole remedy and is in lieu of all other warranties, expressed or implied, including those of merchantability and fitness for a particular purpose. In no event shall Honeywell be liable for consequential, special, or indirect damages.**

While Honeywell may provide application assistance personally, through our literature and the Honeywell web site, it is buyer's sole responsibility to determine the suitability of the product in the application.

Specifications may change without notice. The information we supply is believed to be accurate and reliable as of this writing. However, Honeywell assumes no responsibility for its use.

## FOR MORE INFORMATION

Honeywell Sensing and Internet of Things services its customers through a worldwide network of sales offices and distributors. For application assistance, current specifications, pricing or the nearest Authorized Distributor, visit [sensing.honeywell.com](http://sensing.honeywell.com) or call:

Asia Pacific +65 6355-2828  
Europe +44 1698 481481  
USA/Canada +1-800-537-6945

### Honeywell Sensing and Internet of Things

9680 Old Bailes Road  
Fort Mill, SC 29707  
[honeywell.com](http://honeywell.com)

32305128-F-EN | F | 07/19  
© 2019 Honeywell International Inc. All rights reserved.

## WARNING PERSONAL INJURY

DO NOT USE these products as safety or emergency stop devices or in any other application where failure of the product could result in personal injury.

**Failure to comply with these instructions could result in death or serious injury.**

## WARNING MISUSE OF DOCUMENTATION

- The information presented in this product sheet is for reference only. Do not use this document as a product installation guide.
- Complete installation, operation, and maintenance information is provided in the instructions supplied with each product.

**Failure to comply with these instructions could result in death or serious injury.**

**Honeywell**



Компания «ЭлектроПласт» предлагает заключение долгосрочных отношений при поставках импортных электронных компонентов на взаимовыгодных условиях!

Наши преимущества:

- Оперативные поставки широкого спектра электронных компонентов отечественного и импортного производства напрямую от производителей и с крупнейших мировых складов;
- Поставка более 17-ти миллионов наименований электронных компонентов;
- Поставка сложных, дефицитных, либо снятых с производства позиций;
- Оперативные сроки поставки под заказ (от 5 рабочих дней);
- Экспресс доставка в любую точку России;
- Техническая поддержка проекта, помощь в подборе аналогов, поставка прототипов;
- Система менеджмента качества сертифицирована по Международному стандарту ISO 9001;
- Лицензия ФСБ на осуществление работ с использованием сведений, составляющих государственную тайну;
- Поставка специализированных компонентов (Xilinx, Altera, Analog Devices, Intersil, Interpoint, Microsemi, Aeroflex, Peregrine, Syfer, Eurofarad, Texas Instrument, Miteq, Cobham, E2V, MA-COM, Hittite, Mini-Circuits, General Dynamics и др.);

Помимо этого, одним из направлений компании «ЭлектроПласт» является направление «Источники питания». Мы предлагаем Вам помощь Конструкторского отдела:

- Подбор оптимального решения, техническое обоснование при выборе компонента;
- Подбор аналогов;
- Консультации по применению компонента;
- Поставка образцов и прототипов;
- Техническая поддержка проекта;
- Защита от снятия компонента с производства.



#### Как с нами связаться

**Телефон:** 8 (812) 309 58 32 (многоканальный)

**Факс:** 8 (812) 320-02-42

**Электронная почта:** [org@eplast1.ru](mailto:org@eplast1.ru)

**Адрес:** 198099, г. Санкт-Петербург, ул. Калинина, дом 2, корпус 4, литера А.