



TFT LCD Module Product Specification

DT022CTFT
2.2" (240(RGB) x 320 PIXELS) TFT Module

January 9, 2018

Remark:

Contents in this document are subject to change without notice. No part of this document may be reproduced or transmitted in any form or by any means, electronic or mechanical, for any purpose, without the express written permission of Displaytech Ltd.

Displaytech Ltd.

Tel: (852) 2311 2080 ; Fax: (852) 2722 6998 ; Email: sales@displaytech.com.hk

Address: 31E Billion Plaza 2, No. 10 Cheung Yue Street, Cheung Sha Wan, Kowloon, Hong Kong.

Website: <http://www.displaytech.com.hk>

Revision Record

REV	CHANGES	DATE
1.0	First release	Jan 9, 2018
	-	
	-	

Table of Content

Revision Record	1
1. Scope	3
2. Application	3
3. General Information.....	3
4. Outline Drawing	4
5. Interface Signals	5
6. Absolute Maximum Ratings.....	6
7. Electrical Specifications	6
8. Command/AC Timing	7
9. Optical Specification	12
10. Environmental / Reliability Tests.....	14
11. Precautions for Use of LCD Modules.....	14

1. Scope

This data sheet is to introduce the specification of DT022CTFT active matrix TFT module. It is composed of a color TFT-LCD panel, driver ICs, FPC and a backlight unit. The 2.2" display area contains 240 (RGB) x 320 pixels.

2. Application

Digital equipment which need color display, mobile navigator/video systems.

3. General Information

Item	Contents	Unit
Size	2.2	inch
Resolution	240(RGB) x 320	/
Interface	RGB/MCU	/
Technology Type	a-Si	/
Pixel Pitch	0.141 x 0.141	mm
Pixel Configuration	R.G.B. Vertical Stripe	/
Outline Dimension (W x H x D)	38.50 x 56.16 x 2.35	mm
Active Area	33.84 x 45.12	mm
Display Mode	Normally white, Transmissive	/
Viewing Direction	6 o'clock	/
Backlight Type	LED	/
Driver IC	ILI9341V	/

4. Outline Drawing

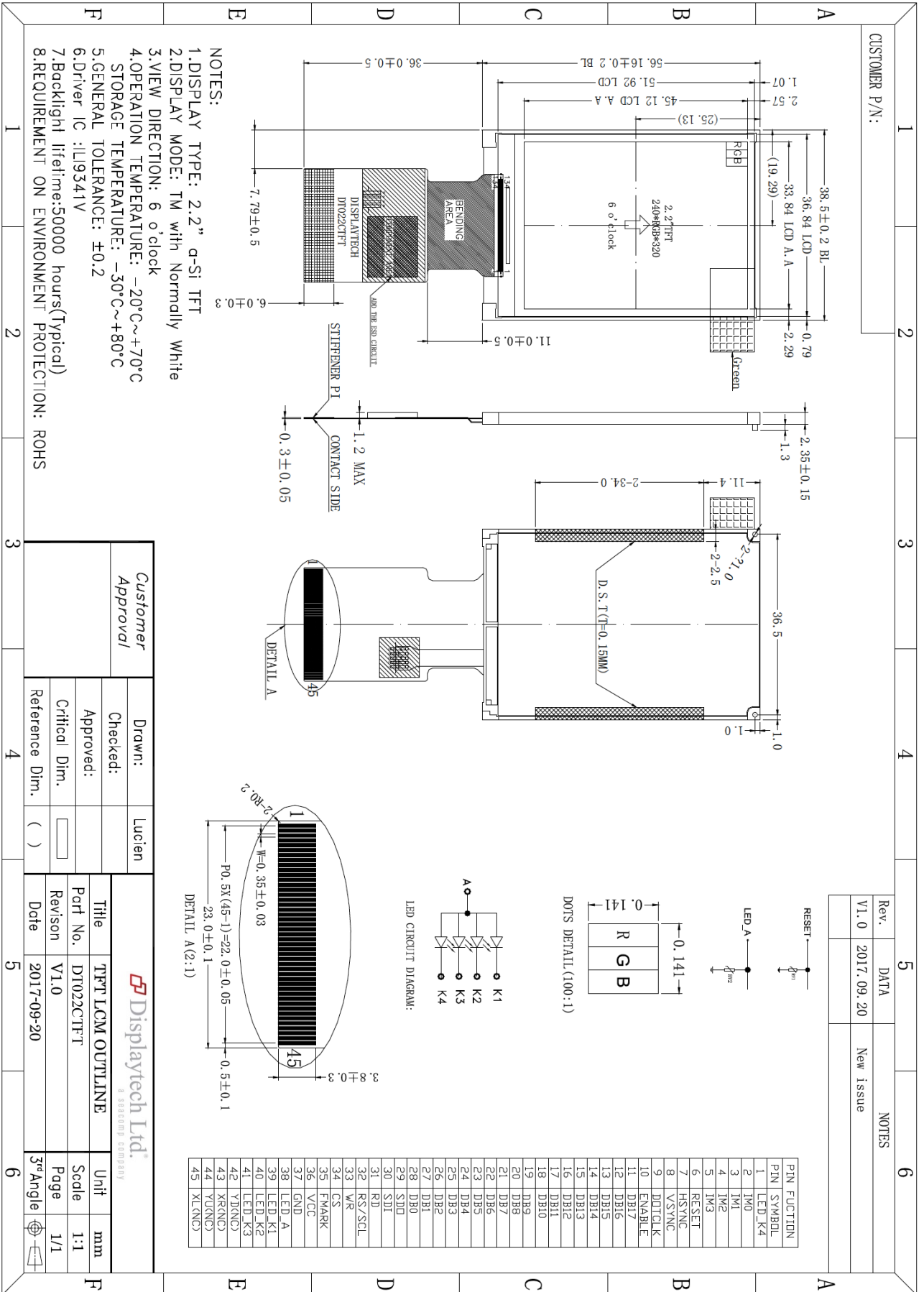

Customer Approval	
Drawn:	Lucien
Checked:	
Approved:	
Critical Dim.	
Reference Dim.	()

Title		TFT LCM OUTLINE	
Part No.		DT022CTFT	
Revision		V1.0	
Date		2017-09-20	

Displaytech Ltd.		a 38800000 COMPANY	
Unit	mm	Scale	1:1
Page	1/1	3rd Angle	

5. Interface Signals

No	Symbol	Description	Remarks
1	LED-K4	LED backlight (Cathode)	
2	IM0	System interface select	Note
3	IM1	System interface select	
4	IM2	System interface select	
5	IM3	System interface select	
6	RESET	Reset signal, Active low	
7	HSYNC	Line sync signal for RGB interface operation	
8	VSYNC	Frame sync signal for RGB interface operation	
9	DOTCLK	Dot clock signal for RGB interface operation	
10	ENABLE	Data enable signal for RGB interface operation	
11 ~ 28	DB17 ~ DB0	Data bus	
29	SDO	Serial data output in serial bus system interface	
30	SDI	Serial data Input in serial bus system interface	
31	RD	Read enable pin I80 parallel bus system interface	
32	RS/SCL	RS: Data or Command select pin in parallel interface When RS="1", data is selected When RS="0", command is selected SCL: Serial data clock in serial bus system	
33	WR	Write enable pin in I80 parallel bus system interface	
34	CS	Chip select signal	
35	FMARK	Tearing effect output pin to synchronize MPU to frame writing	
36	VCC	Power supply	
37	GND	Ground	
38	LED-A	LED backlight (Anode)	
39	LED-K1	LED backlight (Cathode)	
40	LED-K2	LED backlight (Cathode)	
41	LED-K3	LED backlight (Cathode)	
42	YD (NC)	Touch panel pin (No connection)	
43	XR (NC)	Touch panel pin (No connection)	
44	YU (NC)	Touch panel pin (No connection)	
45	XL (NC)	Touch panel pin (No connection)	

Note:

IM3	IM2	IM1	IM0	Interface	DB Pin in use	
					Register/Content	GRAM
0	0	0	0	80 MCU 8-bit bus interface I	DB[7:0]	DB[7:0]
0	0	0	1	80 MCU 16-bit bus interface I	DB[7:0]	DB[15:0]
0	0	1	0	80 MCU 9-bit bus interface I	DB[7:0]	DB[8:0]
0	0	1	1	80 MCU 18-bit bus interface I	DB[7:0]	DB[17:0]
0	1	0	1	3-line 9-bit data serial interface I	SDA: In/Out	
0	1	1	0	4-line 8-bit data serial interface I	SDA: In/Out	
1	0	0	0	80 MCU 16-bit bus interface II	DB[8:1]	DB[17:10] DB[8:1]
1	0	0	1	80 MCU 8-bit bus interface II	DB[17:10]	DB[17:10]
1	0	1	0	80 MCU 18-bit bus interface II	DB[8:1]	DB[17:0]
1	0	1	1	80 MCU 9-bit bus interface II	DB[17:10]	DB[17:9]
1	1	0	1	3-line 9-bit data serial interface II	SDI: In, SDO: Out	
1	1	1	0	4-line 8-bit data serial interface II	SDI: In, SDO: Out	

6. Absolute Maximum Ratings

6.1 Electrical absolute maximum ratings

Parameter	Symbol	MIN	MAX	Unit	Remark
Power Supply Voltage	VCC	-0.3	3.6	V	

Notes:

- If the module is above these absolute maximum ratings. It may become permanently damaged. Using the module within the following electrical characteristic conditions are also exceeded, the module will malfunction and cause poor reliability.
- VCC > VSS must be maintained.

6.2 Environment conditions

Parameter	Symbol	MIN	MAX	Unit	Remark
Operating Temperature	TOPR	-20	+70	°C	
Storage Temperature	TSTG	-30	+80	°C	

Note:

- The response time will become lower when operated at low temperature.
- Background color changes slightly depending on ambient temperature. The phenomenon is reversible.
- Ta ≤ 40°C : 85%RH MAX.
Ta > 40°C : Absolute humidity must be lower than the humidity of 85%RH at 40°C.

7. Electrical Specifications

7.1 Electrical characteristics

GND=0V, Ta=25°C

Item	Symbol	MIN	TYP	MAX	Unit	Remark	
Power Supply	VCC	2.6	2.8	3.3	V	Ta=25°C	
Input Signal Voltage	Low Level	VIL	0	-	0.2VCC	V	VCC=2.8V
	High Level	VIH	0.8VCC	-	VCC	V	VCC=2.8V
Current Consumption	ICC1	-	5	10	mA	Normal mode	
	ICC2	-	0.05	0.1	mA	Sleep mode	

Note: Tested in 1×1 chessboard pattern.

7.2 LED backlight

Ta=25°C

Item	Symbol	MIN	TYP	MAX	Unit	Remark
Forward current	IF	-	60	-	mA	
Forward voltage	VF	-	3.0	-	V	
LED life time	-	-	50,000	-	Hrs	Note

Note : The "LED life time" is defined as the module brightness decrease to 50% original brightness at Ta=25°C and IL =60mA. The LED lifetime could be decreased if operating IL is larger than 60mA.

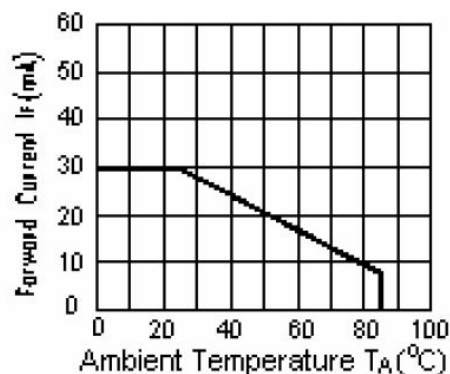

8. Command/AC Timing

8.1 Display Parallel 18/16/9/8-bit Interface Timing Characteristics (8080-I system)

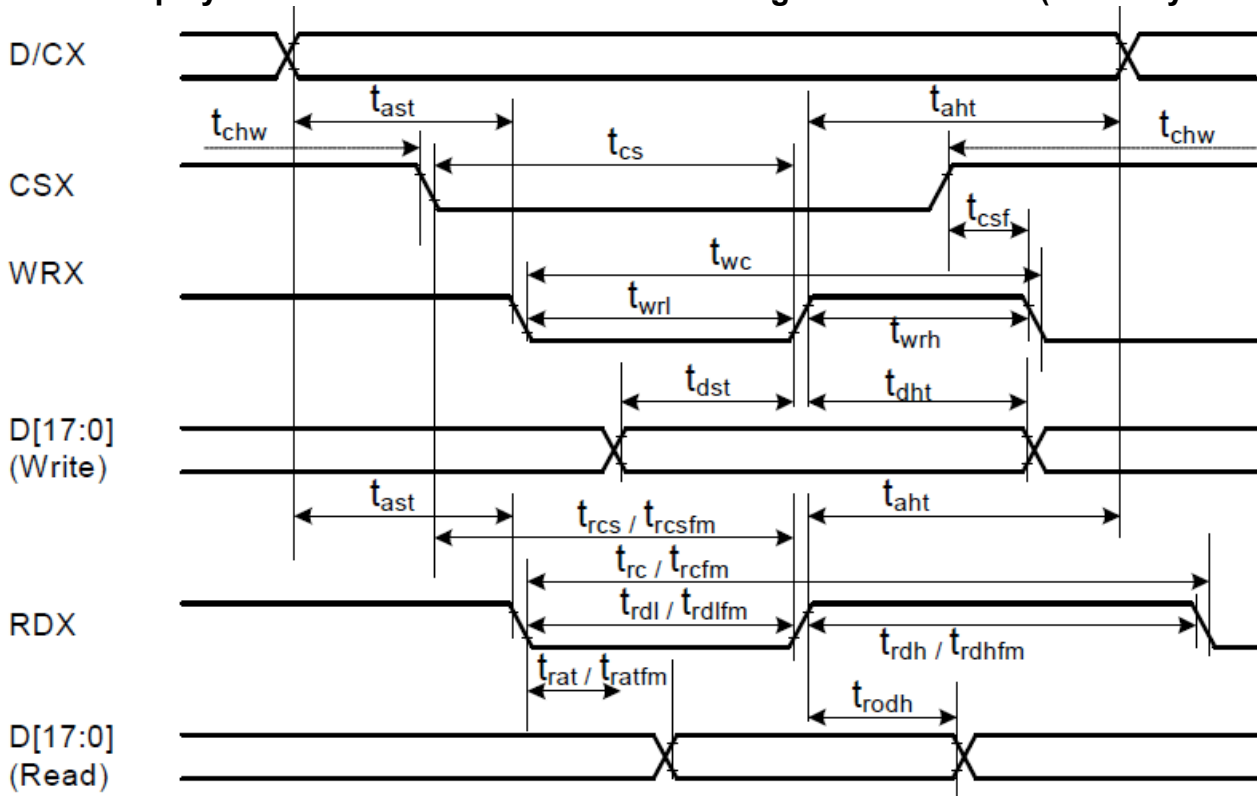

Signal	Symbol	Parameter	Min.	Max.	Unit	Description
DCX	tast	Address setup time	0	-	ns	
	taht	Address hold time (Write/Read)	0	-	ns	
CSX	tchw	CSX "H" pulse width	0	-	ns	
	tcs	Chip Select setup time (Write)	15	-	ns	
	trcs	Chip Select setup time (Read ID)	45	-	ns	
	trcsfm	Chip Select setup time (Read FM)	355	-	ns	
	tcsf	Chip Select Wait time (Write/Read)	10	-	ns	
WRX	twc	Write cycle	66	-	ns	
	twrh	Write Control pulse H duration	15	-	ns	
	twrl	Write Control pulse L duration	15	-	ns	
RDX(FM)	trcfm	Read Cycle (FM)	450	-	ns	
	trdhfm	Read Control H duration (FM)	90	-	ns	
	trdlfm	Read Control L duration (FM)	355	-	ns	
RDX(ID)	trc	Read cycle (ID)	160	-	ns	
	trdh	Read Control pulse H duration	90	-	ns	
	trdl	Read Control pulse L duration	45	-	ns	
D[17:0] D[15:0] D[8:0] D[7:0]	tdst	Write data setup time	10	-	ns	For maximum CL=30pF For minimum CL=8pF
	tdht	Write data hold time	10	-	ns	
	trat	Read access time	-	40	ns	
	tratfm	Read access time	-	340	ns	
	trod	Read output disable time	20	80	ns	

Note 1: Ta= -30 to 70°C, VDDI=1.65 to 3.3V, VCI=2.5 to 3.3V, VSS=0V.

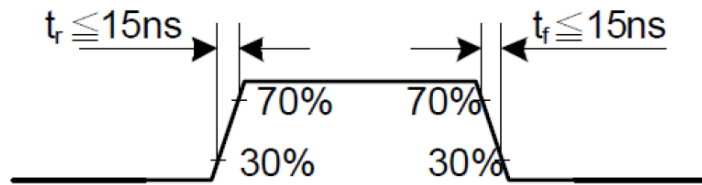

CSX timings:

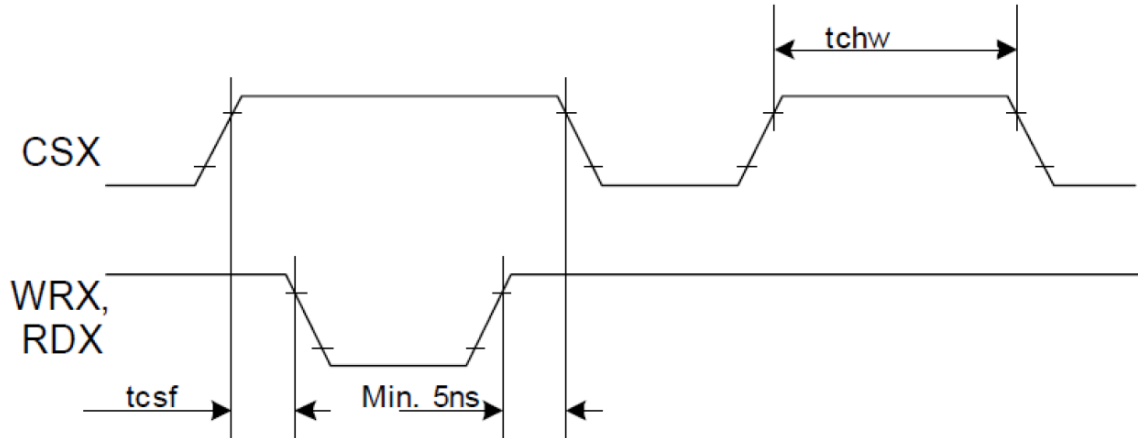

Note: Logic high and low levels are specified as 30% and 70% of VDDI for input signals.

Write to read or read to write timings:

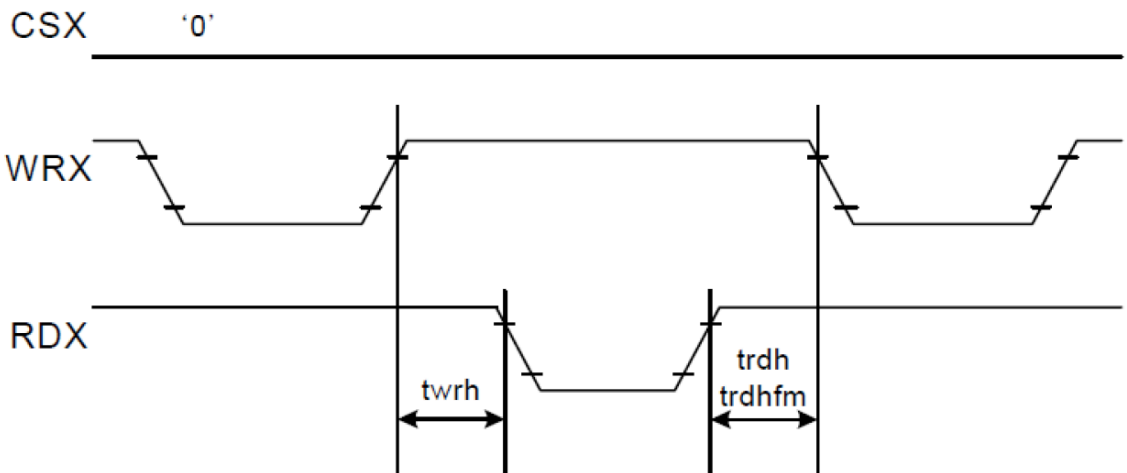

Note: Logic high and low levels are specified as 30% and 70% of VDDI for input signals.

8.2 Display Parallel 18/16/9/8-bit Interface Timing Characteristics (8080-II system)

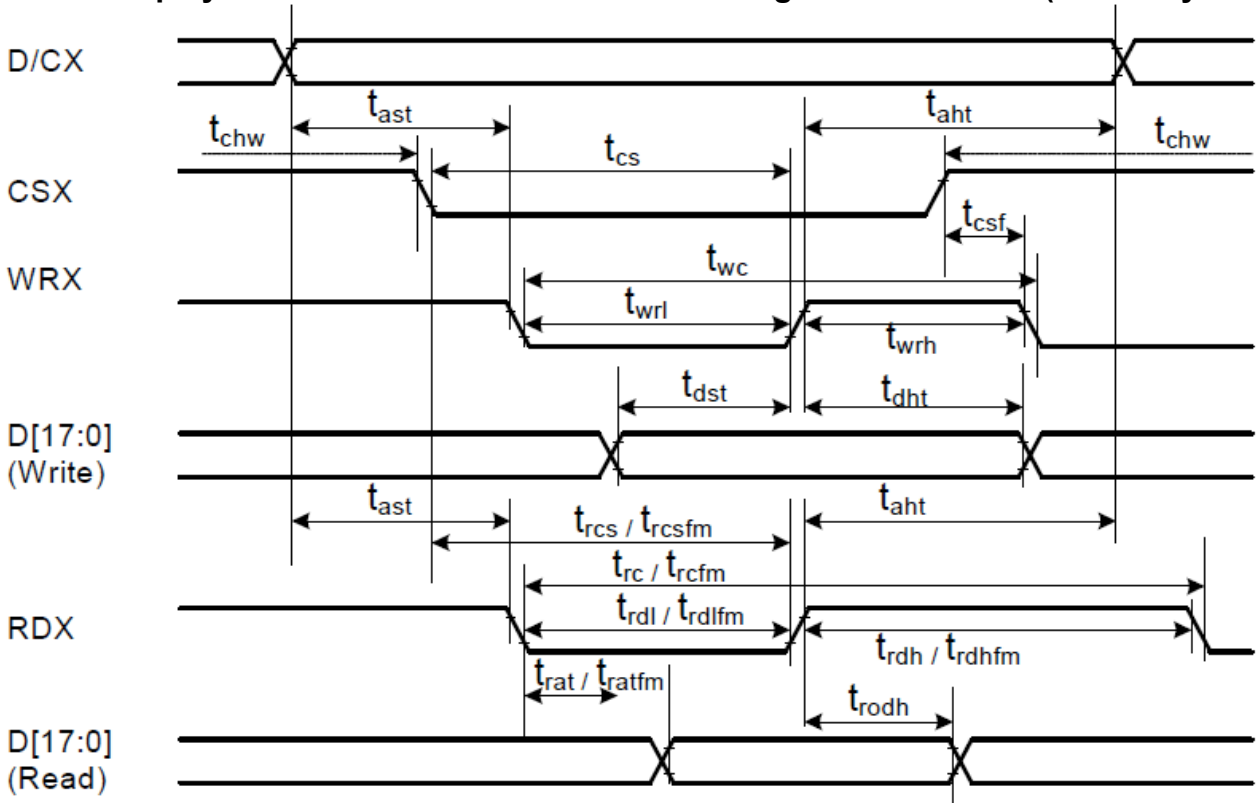

Signal	Symbol	Parameter	Min.	Max.	Unit	Description
DCX	tast	Address setup time	0	-	ns	
	taht	Address hold time (Write/Read)	0	-	ns	
CSX	tchw	CSX "H" pulse width	0	-	ns	
	tcs	Chip Select setup time (Write)	15	-	ns	
	trcs	Chip Select setup time (Read ID)	45	-	ns	
	trcsfm	Chip Select setup time (Read FM)	355	-	ns	
	tcsf	Chip Select Wait time (Write/Read)	10	-	ns	
WRX	twc	Write cycle	66	-	ns	
	twrh	Write Control pulse H duration	15	-	ns	
	twrl	Write Control pulse L duration	15	-	ns	
RDX(FM)	trcfm	Read Cycle (FM)	450	-	ns	
	trdhfm	Read Control H duration (FM)	90	-	ns	
	trdlfm	Read Control L duration (FM)	355	-	ns	
RDX(ID)	trc	Read cycle (ID)	160	-	ns	
	trdh	Read Control pulse H duration	90	-	ns	
	trdl	Read Control pulse L duration	45	-	ns	
D[17:0] D[17:0]&D[8:1] D[17:10] D[17:9]	tdst	Write data setup time	10	-	ns	For maximum CL=30pF For minimum CL=8pF
	tdht	Write data hold time	10	-	ns	
	trat	Read access time	-	40	ns	
	tratfm	Read access time	-	340	ns	
	trod	Read output disable time	20	80	ns	

Note 1: Ta= -30 to 70°C, VDDI=1.65 to 3.3V, VCI=2.5 to 3.3V, VSS=0V.

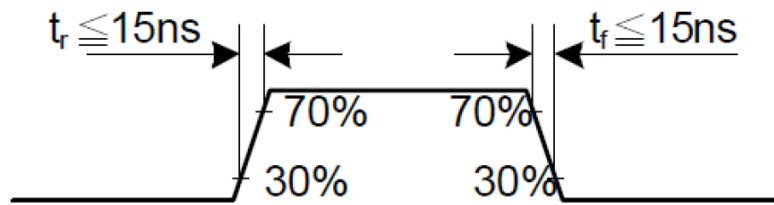

CSX timings:

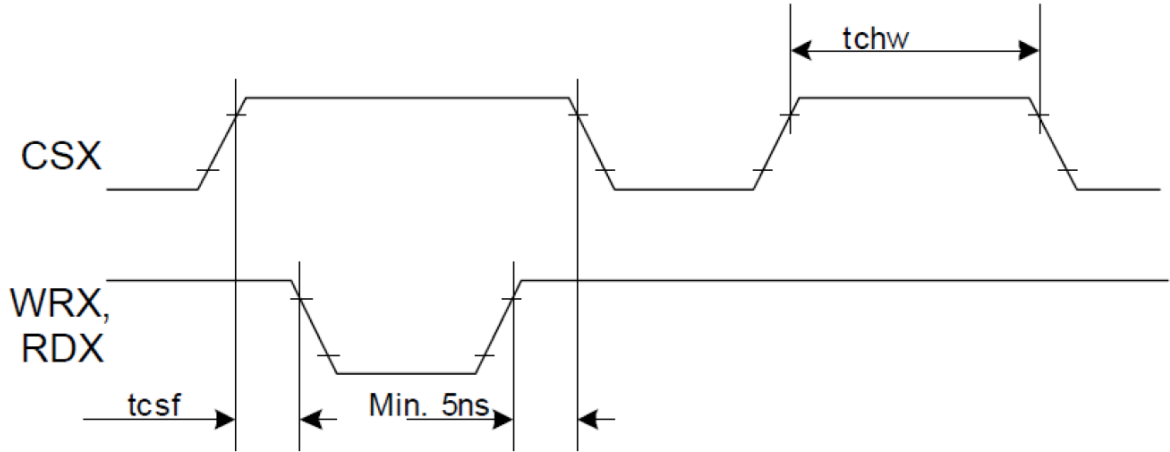

Note: Logic high and low levels are specified as 30% and 70% of VDDI for input signals.

Write to read to read to write timings:

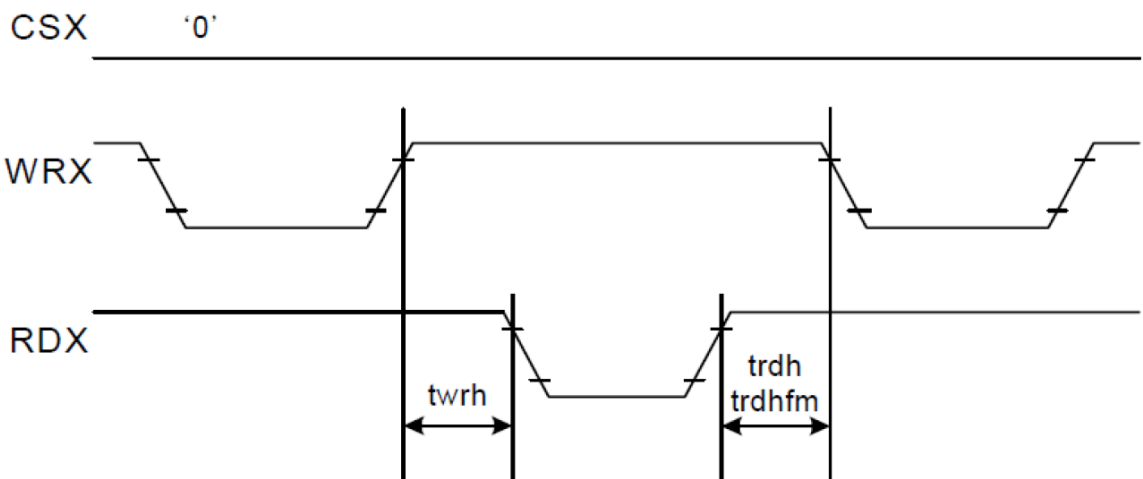

Note: Logic high and low levels are specified as 30% and 70% of VDDI for input signals.

8.3 Parallel 18/16/6-bit RGB Interface Timing Characteristics

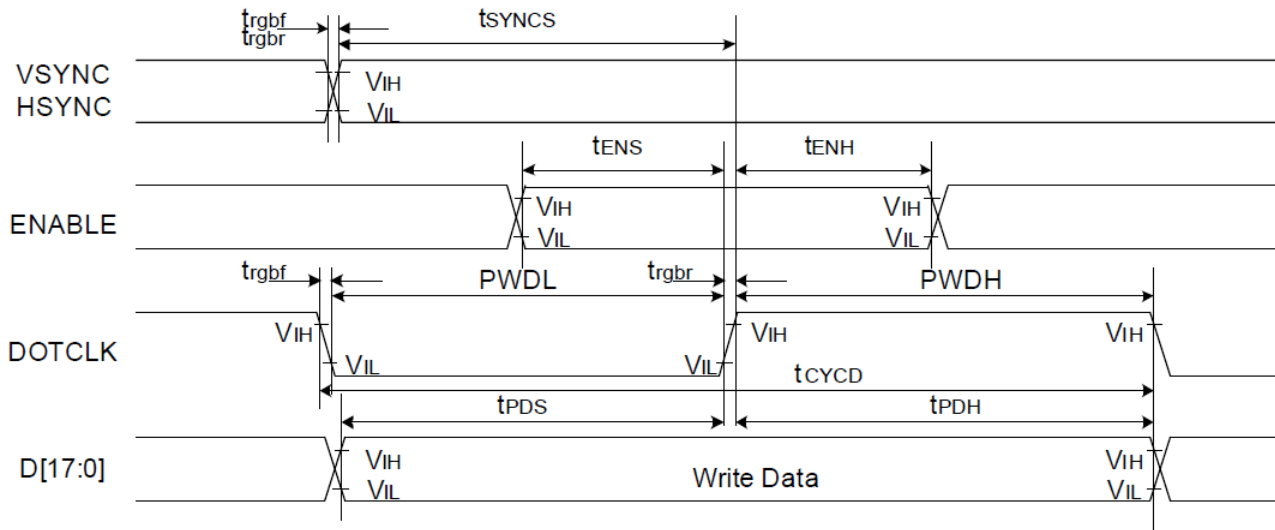

Signal	Symbol	Parameter	Min.	Max.	Unit	Description	
VSYNC/ HSYNC	t_{synCS}	VSYNC/HSYNC setup time	15	-	ns	18/16-bit bus RGB interface mode	
	t_{synCH}	VSYNC/HSYNC hold time	15	-	ns		
DE	t_{ENS}	DE setup time	15	-	ns		
	t_{ENH}	DE hold time	15	-	ns		
D[17:0]	t_{POS}	Data setup time	15	-	ns		
	t_{PDH}	Data hold time	15	-	ns		
DOTCLK	PWDH	DOTCLK high-level period	15	-	ns		
	PWDL	DOTCLK low-level period	15	-	ns		
	t_{CYCD}	DOTCLK cycle time	100	-	ns		
	t_{rgbr}, t_{rgbf}	DOTCLK, HSYNC, VSYNC rise/fall time	-	15	ns		
VSYNC/ HSYNC	t_{synCS}	VSYNC/HSYNC setup time	15	-	ns		6-bit bus RGB interface mode
	t_{synCH}	VSYNC/HSYNC hold time	15	-	ns		
DE	t_{ENS}	DE setup time	15	-	ns		
	t_{ENH}	DE hold time	15	-	ns		
D[17:0]	t_{POS}	Data setup time	15	-	ns		
	t_{PDH}	Data hold time	15	-	ns		
DOTCLK	PWDH	DOTCLK high-level period	15	-	ns		
	PWDL	DOTCLK low-level period	15	-	ns		
	t_{CYCD}	DOTCLK cycle time	50	-	ns		
	t_{rgbr}, t_{rgbf}	DOTCLK, HSYNC, VSYNC rise/fall time	-	15	ns		

Note 1: $T_a = -30$ to 70°C , $V_{DDI} = 1.65$ to 3.3V , $V_{CI} = 2.5$ to 3.3V , $AGND = VSS = 0\text{V}$.

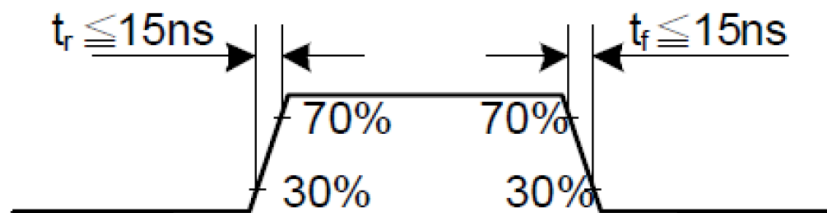

9. Optical Specification

Item	Symbol	Condition	MIN	TYP	MAX	Unit	Remark
Contrast ratio	CR	$\theta=0^\circ$	300	500	-		Note 1, 2
Response time	Tr	25°C	-	10	-	ms	Note 1, 3
	Tf		-	10	-		
View angles	θT	CR ≥ 10	-	55	-	Degree	Note 4
	θB		-	65	-		
	θL		-	65	-		
	θR		-	65	-		
Chromaticity	White	Brightness is on	x	0.28	-		Note 1, 5
			y	0.33	-		
	Red		x	0.51	-		
			y	0.34	-		
	Green		x	0.31	-		
			y	0.56	-		
Blue	x	0.15	-				
	y	0.14	-				
NTSC Ratio	S		50	60		%	Note 1, 5
Luminance	L		250	330	-	cd/m ²	Note 1, 6
Uniformity	U		-	80	-	%	Note 1, 7

Note 1: Definition of optical measurement system.

Temperature = 25°C(±3°C)

LED back-light: ON, Environment brightness < 150 lx

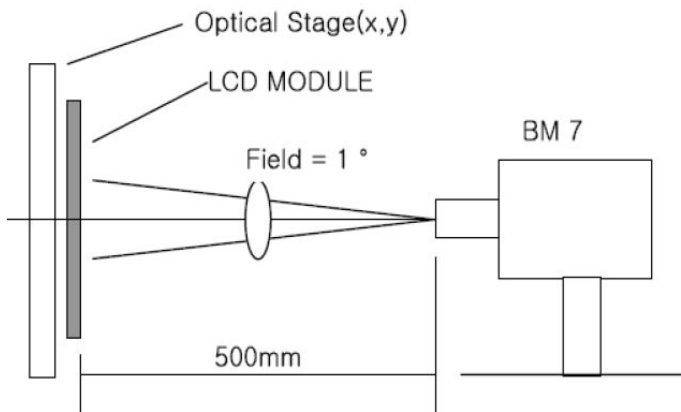

Note 2: Contrast ratio is defined as follow:

$$\text{Contrast Ratio} = \frac{\text{Surface Luminance with all white pixels}}{\text{Surface Luminance with all black pixels}}$$

Note 3: Response time is defined as follow:

Response time is the time required for the display to transition from black to white (Rise time, Tr) and from white to black (Decay Time, Tf).

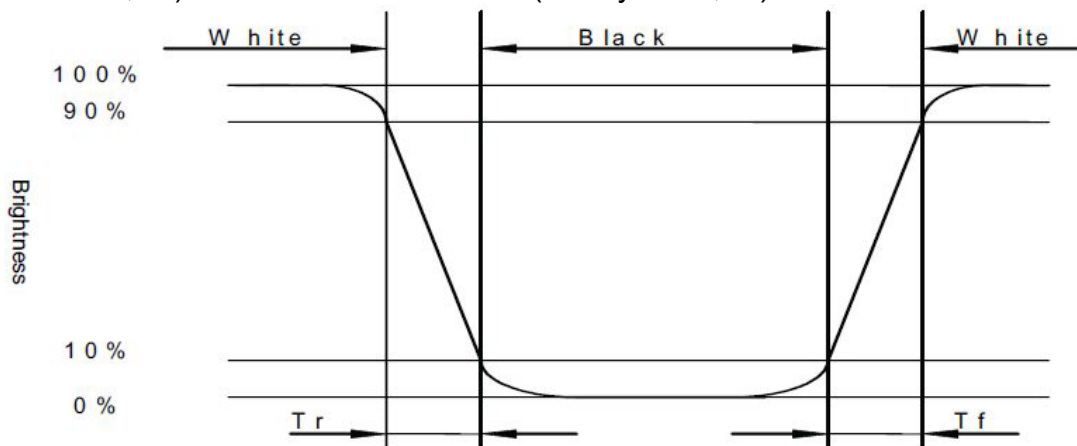

Note 4: Viewing angle range is defined as follow:

Viewing angle is measured at the center point of the LCD.

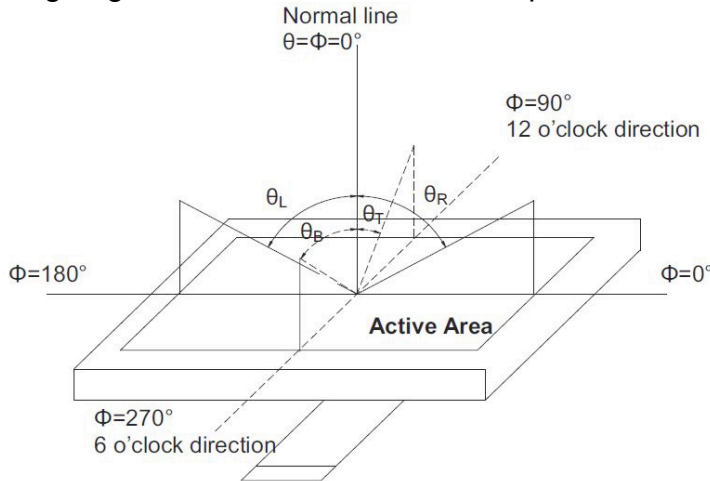

Note 5: Color chromaticity is defined as follow (CIE1931)

Color coordinates measured at center point of LCD.

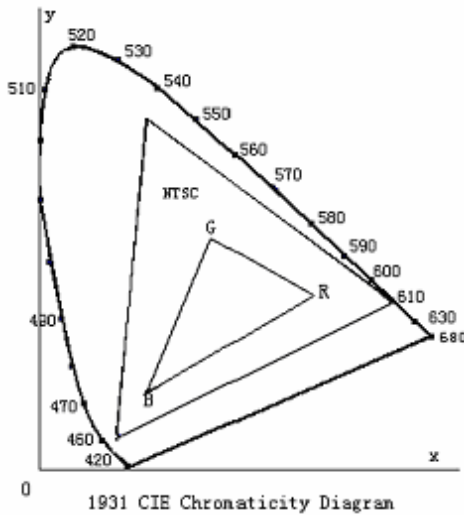

$$S = \frac{\text{area of RGB triangle}}{\text{area of NTSC triangle}} \times 100\%$$

Note 6: Luminance is defined as follow:

Luminance is defined as the brightness of all pixels “White” at the center of display area on optimum contrast.

Note 7: Luminance Uniformity is defined as follow:

Active area is divided into 9 measuring areas (Refer Fig.2). Every measuring point is placed at the center of each measuring area.

$$\text{Uniformity (U)} = \frac{\text{Minimum Luminance(brightness) in 9 points}}{\text{Maximum Luminance(brightness) in 9 points}}$$

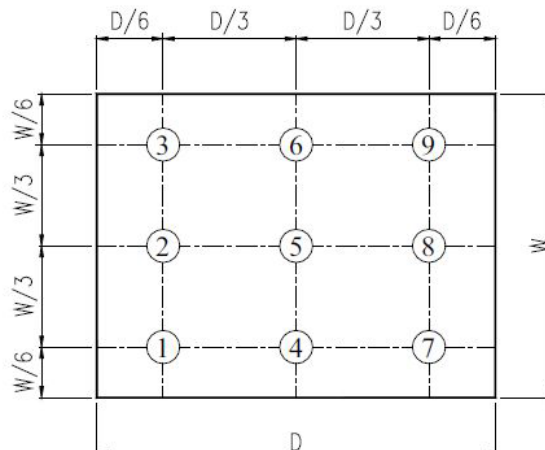

Fig. 2 Definition of uniformity

10. Environmental / Reliability Tests

No	Test Item	Condition	Judgment Criteria
1	High Temp Operation	Ta=+70°C, 96hrs	Per table below
2	Low Temp Operation	Ta=-20°C, 96hrs	Per table below
3	High Temp Storage	Ta=+80°C, 96hrs	Per table below
4	Low Temp Storage	Ta=-30°C, 96hrs	Per table below
5	High Temp & High Humidity Storage	Ta=+60°C, 90% RH, 96hrs	Per table below (polarizer discoloration is excluded)
6	Thermal Shock (Non-operation)	-30°C 30 min~+70°C 30 min, Change time: 5min, 10 Cycles	Per table below
7	ESD (Operation)	C=150pF, R=330Ω, 5points/panel Air:±8KV, 5times; Contact:±4KV, 5 times;	Per table below
8	Vibration (Non-operation)	Frequency range: 10~55Hz, Stroke: 1.5mm Sweep: 10Hz~55Hz~10Hz 2 hours for each direction of X.Y.Z.	Per table below
9	Shock (Non-operation)	60G 6ms, ±X,±Y,±Z 3times, for each direction	Per table below
10	Package Drop Test	Height: 80cm, 1 corner, 3 edges, 6 surfaces	Per table below

Inspection	Criterion (after test)
Appearance	No crack on the FPC, on the LCD panel
Alignment of LCD panel	No bubbles in the LCD panel No other defects of alignment in active area
Electrical current	Within device specifications
Function / Display	No broken circuit, no short circuit or no black line No other defects of display

11. Precautions for Use of LCD Modules

11.1 Safety

The liquid crystal in the LCD is poisonous. Do not put it in your mouth. If the liquid crystal touches your skin or clothes, wash it off immediately using soap and water.

11.2 Handling

- The LCD and touch panel is made of plate glass. Do not subject the panel to mechanical shock or to excessive force on its surface.
- Do not handle the product by holding the flexible pattern portion in order to assure the reliability.
- Transparency is an important factor for the touch panel. Please wear clear finger sacks, gloves and mask to protect the touch panel from finger print or stain and also hold the portion outside the view area when handling the touch panel.
- Provide a space so that the panel does not come into contact with other components.
- To protect the product from external force, put a covering lens (acrylic board or similar board) and keep an appropriate gap between them.
- Transparent electrodes may be disconnected if the panel is used under environmental conditions where dew condensation occurs.

- g. Property of semiconductor devices may be affected when they are exposed to light, possibly resulting in IC malfunctions.
- h. To prevent such IC malfunctions, your design and mounting layout shall be done in the way that the IC is not exposed to light in actual use.

11.3 Static electricity

- a. Ground soldering iron tips, tools and testers when they are in operation.
- b. Ground your body when handling the products.
- c. Power on the LCD module before applying the voltage to the input terminals.
- d. Do not apply voltage which exceeds the absolute maximum rating.
- e. Store the products in an anti-electrostatic bag or container.

11.4 Storage

- a. Store the products in a dark place at $+25^{\circ}\text{C}\pm 10^{\circ}\text{C}$ with low humidity (40% RH to 60% RH). Don't expose to sunlight or fluorescent light.
- b. Storage in a clean environment, free from dust, active gas, and solvent.

10.5 Cleaning

- a. Do not wipe the touch panel with dry cloth, as it may cause scratch.
- b. Wipe off the stain on the product by using soft cloth moistened with ethanol. Do not allow ethanol to get in between the upper film and the bottom glass. It may cause peeling issue or defective operation. Do not use any organic solvent or detergent other than ethanol.

11.6 Cautions for installing and assembling

- a. Bezel edge must be positioned in the area between the Active area and View area. The bezel may press the touch screen and cause activation if the edge touches the active area. A gap of approximately 0.5mm is needed between the bezel and the top electrode. It may cause unexpected activation if the gap is too narrow. There is a tolerance of 0.2 to 0.3mm for the outside dimensions of the touch panel and tail. A gap must be made to absorb the tolerance in the case and connector.
- b. In order to make the display assembly stable and firm, DLC recommends to design some supporting at the display backside, especially for the display with tape-attached touch panel, such supporting is important and essential, or else, the display may drop-off from front after some period of time.
- c. Do not display the fixed pattern for a long time because it may develop image sticking due to the LCD structure. If the screen is displayed with fixed pattern, use a screen saver.

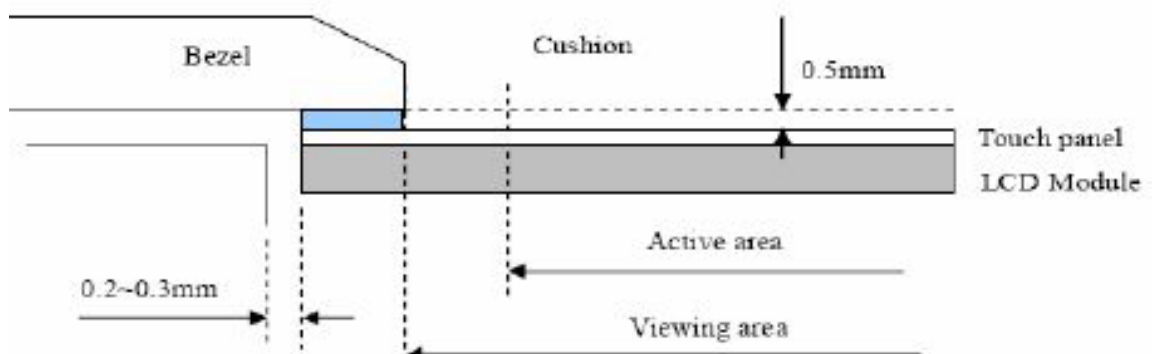



Компания «ЭлектроПласт» предлагает заключение долгосрочных отношений при поставках импортных электронных компонентов на взаимовыгодных условиях!

Наши преимущества:

- Оперативные поставки широкого спектра электронных компонентов отечественного и импортного производства напрямую от производителей и с крупнейших мировых складов;
- Поставка более 17-ти миллионов наименований электронных компонентов;
- Поставка сложных, дефицитных, либо снятых с производства позиций;
- Оперативные сроки поставки под заказ (от 5 рабочих дней);
- Экспресс доставка в любую точку России;
- Техническая поддержка проекта, помощь в подборе аналогов, поставка прототипов;
- Система менеджмента качества сертифицирована по Международному стандарту ISO 9001;
- Лицензия ФСБ на осуществление работ с использованием сведений, составляющих государственную тайну;
- Поставка специализированных компонентов (Xilinx, Altera, Analog Devices, Intersil, Interpoint, Microsemi, Aeroflex, Peregrine, Syfer, Eurofarad, Texas Instrument, Miteq, Cobham, E2V, MA-COM, Hittite, Mini-Circuits, General Dynamics и др.);

Помимо этого, одним из направлений компании «ЭлектроПласт» является направление «Источники питания». Мы предлагаем Вам помощь Конструкторского отдела:

- Подбор оптимального решения, техническое обоснование при выборе компонента;
- Подбор аналогов;
- Консультации по применению компонента;
- Поставка образцов и прототипов;
- Техническая поддержка проекта;
- Защита от снятия компонента с производства.



Как с нами связаться

Телефон: 8 (812) 309 58 32 (многоканальный)

Факс: 8 (812) 320-02-42

Электронная почта: org@eplast1.ru

Адрес: 198099, г. Санкт-Петербург, ул. Калинина, дом 2, корпус 4, литера А.