

# RFSW6232

General Purpose Differential 3T Switch  
50MHz to 6000MHz

The RFSW6232 is a Differential Three Throw Switch that offers very low insertion loss along with excellent linearity performance. It is ideal for filter switching to 6000MHz. The RFSW6232 is compatible with +1.8V control logic and is packaged in a compact 2mm x 2mm, 18-pin, leadless QFN package which allows for a very small solution size and no requirements for external DC blocking capacitors, unless external DC is applied to the device ports.

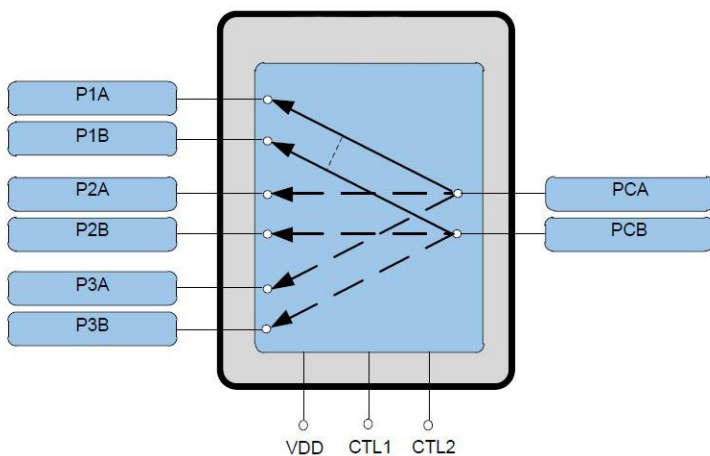

Functional Block Diagram



Package: QFN, 18-pin,  
2.0mm x 2.0mm

## Features

- Very Low Insertion Loss and High Isolation
  - <0.5dB Insertion Loss 1GHz
  - >20dB Isolation at 2.5GHz Typical
- Power Handling to 36dBm
- Low Phase Error +/-3° at 2GHz
- Multi-Band Operation 50MHz to 6000MHz
- HBM ESD Rating >2kV on All Ports
- QFN Package, 2mm x 2mm x 0.55mm, 18-Pin
- No DC Blocking Capacitors Required in Most Applications

## Applications

- Filter Switching
- Antenna Switching
- Differential Switching

## Ordering Information

RFSW6232SQ	Sample bag with 25 pieces
RFSW6232SR	7" Reel with 100 pieces
RFSW6232TR7	7" Reel with 2500 pieces
RFSW6232PCK-410	50MHz to 6000MHz PCBA with 5-piece sample bag

## Absolute Maximum Ratings

Parameter	Rating	Unit
V <sub>DD</sub>	3.9	V
C <sub>TL1</sub> , C <sub>TL2</sub>	3.0	dBm
Maximum Input Power - Momentary Infrequent Occurrence	+37.5 in 50Ω, 25°C +37 in 50Ω, 90°C +34.5 in 50Ω, 105°C +32.5 in 6:1, 90°C +30 in 6:1, 105°C	dBm
Maximum Input Power - Continuous Operation	+36 in 50Ω, 25°C +35.5 in 50Ω, 90°C +33 in 50Ω, 105°C +31 in 6:1, 90°C +28.5 in 6:1, 105°C	dBm
Storage Temperature	-65 to +150	°C
ESD Rating - Human Body Model (HBM)	2000	V
Moisture Sensitivity Level	MSL2	



Caution! ESD sensitive device.



RFMD Green: RoHS status based on EU Directive 2011/65/EU (at time of this document revision), halogen free per IEC 61249-2-21, < 1000ppm each of antimony trioxide in polymeric materials and red phosphorus as a flame retardant, and <2% antimony in solder.

Exceeding any one or a combination of the Absolute Maximum Rating conditions may cause permanent damage to the device. Extended application of Absolute Maximum Rating conditions to the device may reduce device reliability. Specified typical performance or functional operation of the device under Absolute Maximum Rating conditions is not implied.

## Recommended Operating Condition

Parameter	Specification			Unit
	Min	Typ	Max	
Operating Temperature Range	-40	25	+105	°C
Operating Junction Temperature			125	°C
Switch Supply Voltage	2.4	3.1	3.5	V

## Nominal Operating Parameters

Parameter	Specification			Unit	Condition
	Min	Typ	Max		
<b>900MHz Specifications</b>					<b>Nominal Conditions Unless Otherwise Stated, V<sub>DD</sub> = 2.7V, V<sub>HIGH</sub> / V<sub>LOW</sub> = 1.8V / 0V, Temp = 25°C, 50Ω, Single-ended</b>
Frequency		900		MHz	
Insertion Loss (P1, P2 or P3 to PC)		0.36	0.5	dB	900MHz
Isolation					
P1 to P2 or P3	25	28		dB	900MHz; S1, S2, or S3 active
P1, P2 or P3 to PC	25	38		dB	900MHz; HI mode active
Harmonics					
P1, P2 or P3 to PC, 2F <sub>0</sub>	-85	-100		dBc	P <sub>IN</sub> = 26dBm, CW, 900MHz
P1, P2 or P3 to PC, 3F <sub>0</sub>	-85	-98		dBc	
P1, P2 or P3 to PC, up to 2.75GHz	-85	-103		dBc	

Parameter	Specification			Unit	Condition
	Min	Typ	Max		
<b>900MHz Specifications – Continued</b>					<b>Nominal Conditions Unless Otherwise Stated, <math>V_{DD} = 2.7V</math>, <math>V_{HIGH} / V_{LOW} = 1.8V / 0V</math>, Temp = 25°C, 50Ω, Single-ended</b>
Input IP2	110	120		dBm	$P_{IN} = 20dBm$
Input IP3	65	70		dBm	
Return Loss (P1, P2, P3)		24.7		dB	900MHz; Active to PC
<b>2000MHz Specifications</b>					<b>Nominal Conditions Unless Otherwise Stated, <math>V_{DD} = 2.7V</math>, <math>V_{HIGH} / V_{LOW} = 1.8V / 0V</math>, Temp = 25°C, 50Ω, Single-ended</b>
Frequency		2000		MHz	
Insertion Loss (P1, P2 or P3 to PC)		0.42	0.5	dB	2GHz; S1, S2 or S3 Active
Isolation					
P1 to P2 or P3	20	22.5		dB	2GHz; S1, S2 or S3 Active
P1, P2 or P3 to PC	20	22.5		dB	2GHz; HI Mode Active
Harmonics					
P1, P2 or P3 to PC, $2F_0$	-85	-104		dBc	2GHz
P1, P2 or P3 to PC, $3F_0$	-85	-98		dBc	
P1, P2 or P3 to PC	-85	-103		dBc	
Input IP2	110	120		dBm	$P_{IN} = 20dBm, 2GHz$
Input IP3	65	70		dBm	
Return Loss					
P1A, P2A, P3A		20.9		dB	2GHz
P1B, P2B, P3B		20.9		dB	
Phase Balance (P1, P2, or P3–PC)	-3	1.4	+3	Deg	Test at 1980MHz
<b>2500MHz Specifications</b>					<b>Nominal Conditions Unless Otherwise Stated, <math>V_{DD} = 2.7V</math>, <math>V_{HIGH} / V_{LOW} = 1.8V / 0V</math>, Temp = 25°C, 50Ω, Single-ended</b>
Frequency		2500		MHz	
Insertion Loss (P1, P2 or P3 to PC)		0.45	0.55	dB	2500MHz; S1, S2 or S3 Active
Isolation					
P1 to P2 or P3	16	20.7		dB	2500MHz; S1, S2 or S3 Active
P1, P2 or P3 to PCA	16	21		dB	2500MHz; HI Mode Active
Harmonics					
P1, P2 or P3 to PC, $2F_0$	-85	-98		dBc	2500MHz
P1, P2 or P3 to PC, $3F_0$	-85	-102		dBc	
P1, P2 or P3 to PC, up to 12.75GHz	-85	-103		dBc	
Input IP2 – UMTS Mode	110	115		dBm	$P_{IN} = 20dBm, 2500MHz$

Parameter	Specification			Unit	Condition
	Min	Typ	Max		
<b>2500MHz Specifications – Continued</b>					<b>Nominal Conditions Unless Otherwise Stated, <math>V_{DD} = 2.7V</math>, <math>V_{HIGH} / V_{LOW} = 1.8V / 0V</math>, Temp = 25°C, 50Ω, Single-ended</b>
Input IP3 – UMTS Mode	65	70		dBm	PIN = 20dBm, 2500MHz
Return Loss (P1, P2, P3)		24.7		dB	2500MHz
<b>DC Control and Electrical Specifications</b>					<b>Nominal Conditions Unless Otherwise Stated, <math>V_{DD} = 2.7V</math>, <math>V_{HIGH} / V_{LOW} = 1.8V / 0V</math>, Temp = 25°C, 50Ω, Single-ended</b>
$V_{DD}$ Supply Current	50	75	100	μA	S1, S2 or S3 Mode active
$C_{TL1}$ , $C_{TL2}$ – Control Voltage High	1.3		2.7	V	
$C_{TL1}$ , $C_{TL2}$ – Control Voltage Low	0		0.45	V	
Control Current			1	μA	
Switching Speed		3	5	μs	10% to 90% RF

## Notes:

1. The DP3T switch is controlled by CTL1, CTL2. The poles are synchronized such that each is connected to the same port number.
2. Operation of switch may be delayed up to 100 microseconds after initial application of VDD supply, under extreme cold conditions.

## Mode Control Table

Mode	CTL1	CTL2	Test Condition
P1A – PCA	High	Low	S1
P1B – PCB			
P2A – PCA	Low	Low	S2
P2B – PCB			
P3A – PCA	Low	High	S3
P3B – PCB			
PCA – PCB (High Isolation)	High	High	HI

Note: HI mode connects a termination across PCA-PCB and disconnects P1, P2 and P3 paths.

## Low Frequency Linearity Table

Frequency	2.5MHz	5MHz	25MHz	50MHz
IP3	55dBm	57dBm	64dBm	67dBm
IP2	74dBm	80dBm	86dBm	90dBm

Typical Performance: T = 25°C, V<sub>DD</sub> = 3.3V unless otherwise noted

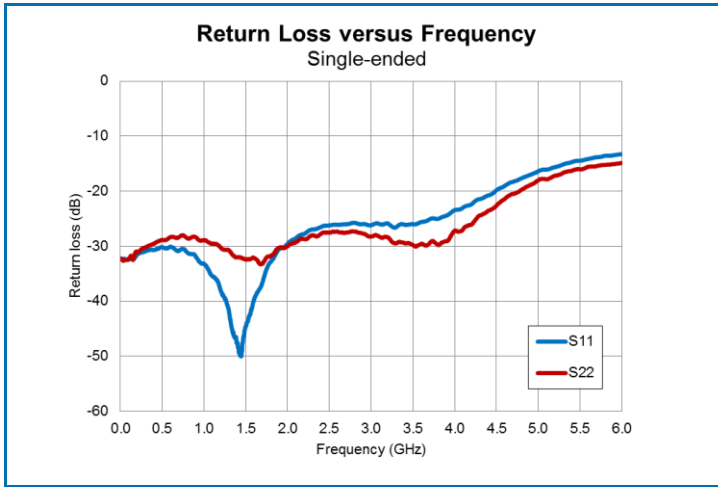
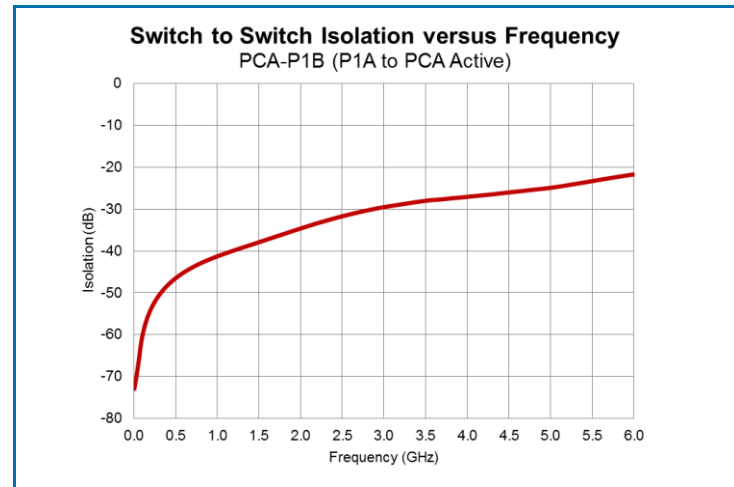
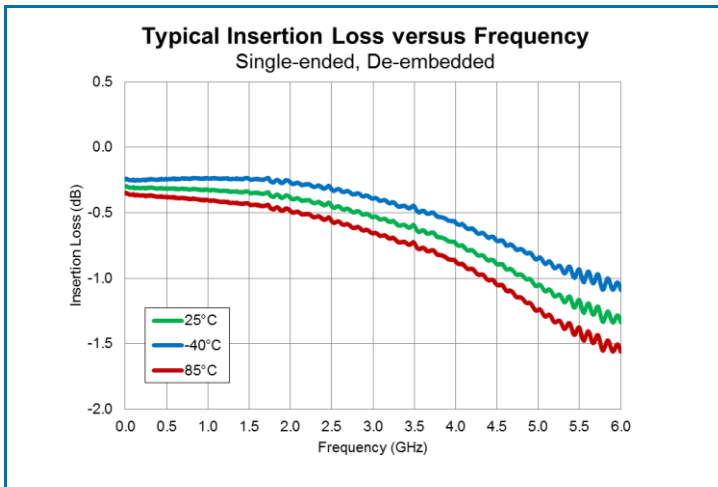

Evaluation Board Schematic 50MHz to 6000MHz Application Circuit

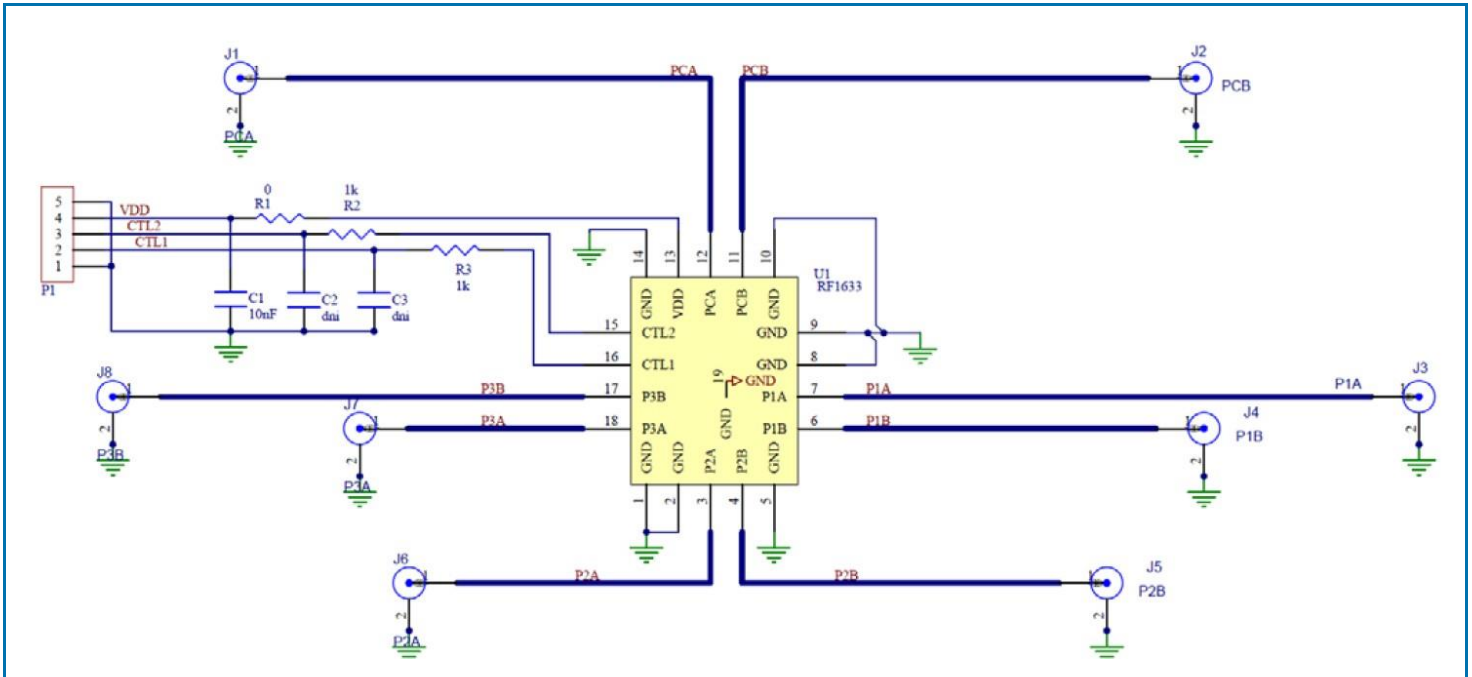

Evaluation Board Bill of Materials (BOM) 50MHz to 6000MHz Application Circuit

Description	Reference Designator	Manufacturer	Manufacturer's P/N
RFSW6232-410(A) Evaluation Board		Viasystems	RFSW6232-410(A)
General Purpose Differential 3T Switch	U1	RFMD	RFSW6232
CAP, 10000pF, 10%, 25V, X7R, 0402	C1	Murata Electronics	GRM155R71E103KA01D
RES, 0Ω, 0402	R1	Kamaya, Inc.	RMC1/16SJPTH
RES, 1K, 5%, 1/16W, 0402	R2-R3	Kamaya, Inc.	RMC1/16S-102JTH
CAP, 100pF, 5%, 50V, C0G, 0402, DNI	C2-C3	Taiyo Yuden (USA), Inc.	RM UMK105CG101JV-F
CONN, SMA, END LNCH, MINI, FLT, 0.068"	PCA, PCB, P1A, P1B, P2A, P2B, P3A, P3B	Emerson Network Power	142-0741-851
CONN, HDR, ST, PLRZD, 5-PIN, 0.100"	P1	ITW Pancon	MPSS100-5-C

Evaluation Board Assembly Drawing

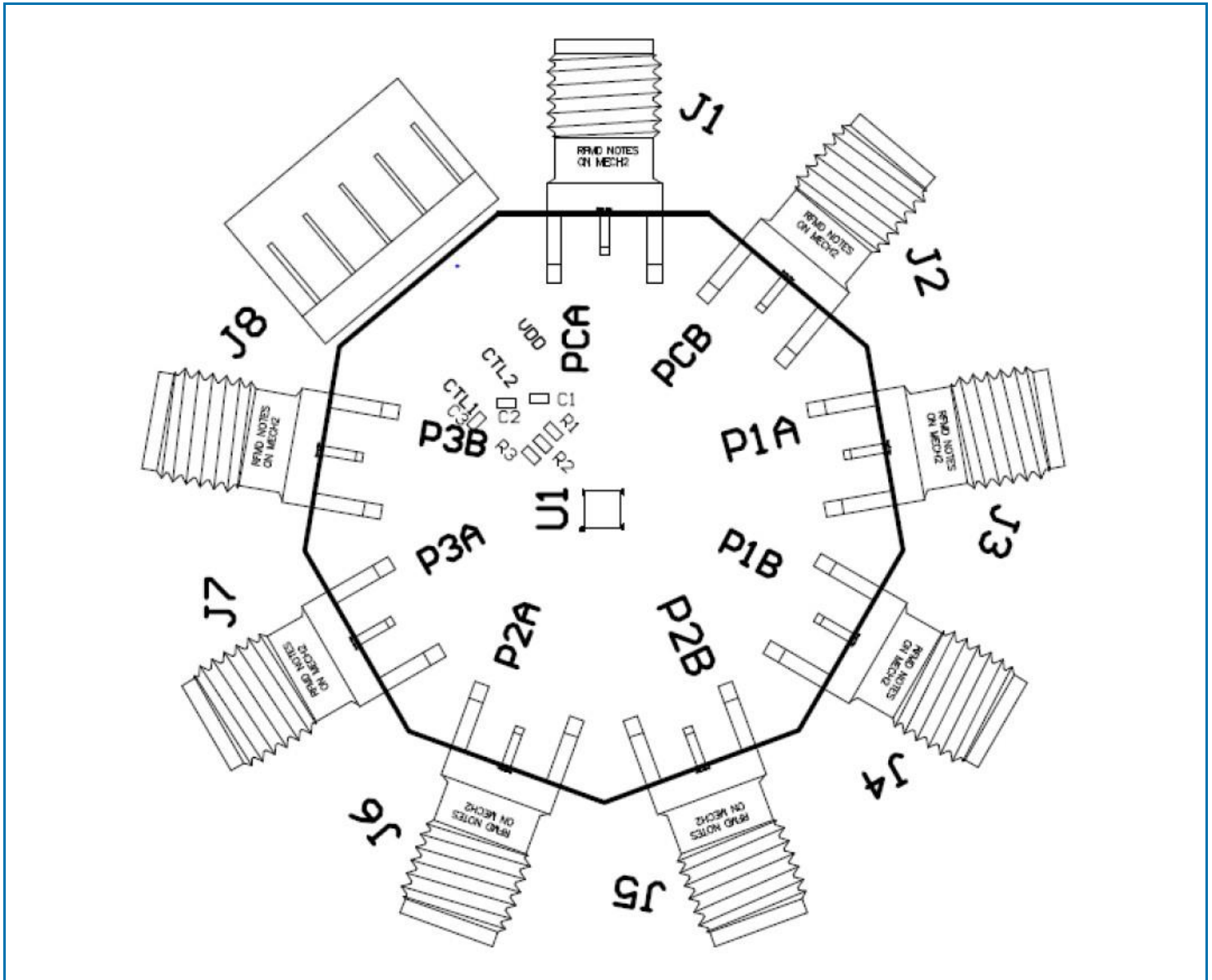

## Pin Names and Descriptions

Pin	Name	Description
1	GND	RF and DC Ground
2	GND	RF and DC Ground
3	P2A	RF Path 2 Pole A
4	P2B	RF Path 2 Pole B
5	GND	RF and DC Ground
6	P1B	RF Path 1 Pole B
7	P1A	RF Path 1 Pole A
8	GND	RF and DC Ground
9	GND	RF and DC Ground
10	GND	RF and DC Ground
11	PCB	Antenna Common Pole B
12	PCA	Antenna Common Pole A
13	VDD	DC Power Supply Input
14	GND	RF and DC Ground
15	CTL2	Control Logic Line 2
16	CTL1	Control Logic Line 1
17	P3B	RF Path 3 Pole B
18	P3A	RF Path 3 Pole A
PKG BASE	GND	RF and DC Ground

## Pin Out Top View

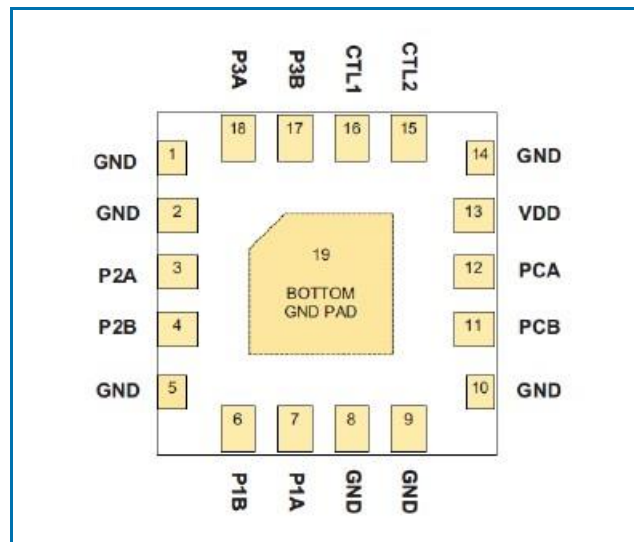



**Package Outline (Dimensions in millimeters)**

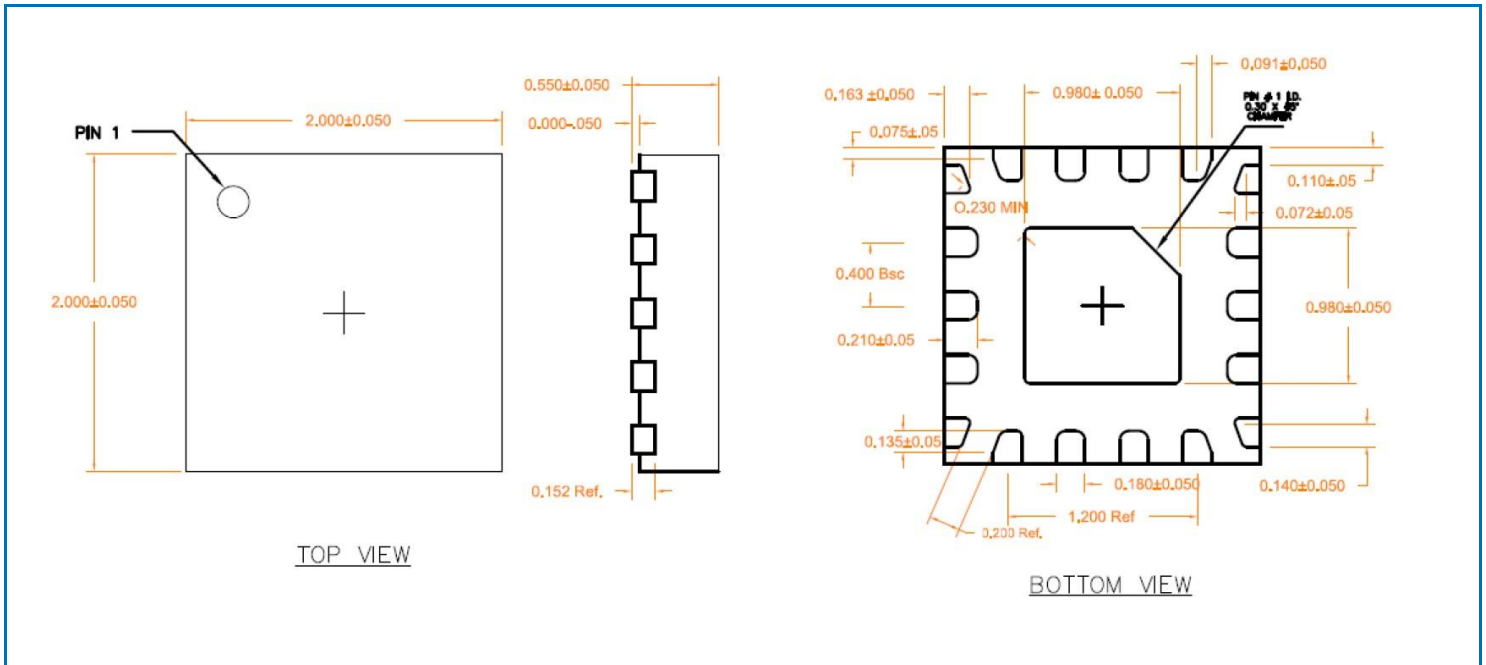

**Branding Diagram**

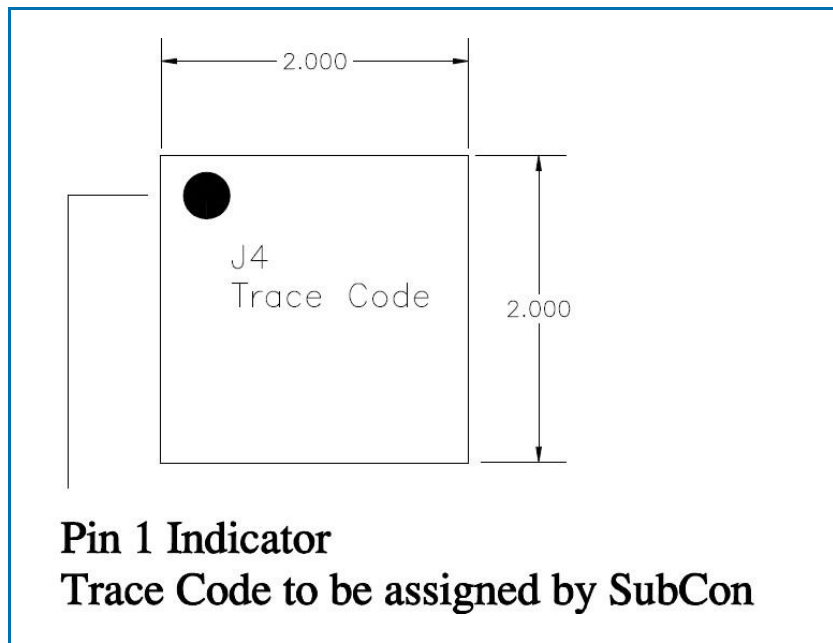



Компания «ЭлектроПласт» предлагает заключение долгосрочных отношений при поставках импортных электронных компонентов на взаимовыгодных условиях!

Наши преимущества:

- Оперативные поставки широкого спектра электронных компонентов отечественного и импортного производства напрямую от производителей и с крупнейших мировых складов;
- Поставка более 17-ти миллионов наименований электронных компонентов;
- Поставка сложных, дефицитных, либо снятых с производства позиций;
- Оперативные сроки поставки под заказ (от 5 рабочих дней);
- Экспресс доставка в любую точку России;
- Техническая поддержка проекта, помощь в подборе аналогов, поставка прототипов;
- Система менеджмента качества сертифицирована по Международному стандарту ISO 9001;
- Лицензия ФСБ на осуществление работ с использованием сведений, составляющих государственную тайну;
- Поставка специализированных компонентов (Xilinx, Altera, Analog Devices, Intersil, Interpoint, Microsemi, Aeroflex, Peregrine, Syfer, Eurofarad, Texas Instrument, Miteq, Cobham, E2V, MA-COM, Hittite, Mini-Circuits, General Dynamics и др.);

Помимо этого, одним из направлений компании «ЭлектроПласт» является направление «Источники питания». Мы предлагаем Вам помощь Конструкторского отдела:

- Подбор оптимального решения, техническое обоснование при выборе компонента;
- Подбор аналогов;
- Консультации по применению компонента;
- Поставка образцов и прототипов;
- Техническая поддержка проекта;
- Защита от снятия компонента с производства.



#### Как с нами связаться

**Телефон:** 8 (812) 309 58 32 (многоканальный)

**Факс:** 8 (812) 320-02-42

**Электронная почта:** [org@eplast1.ru](mailto:org@eplast1.ru)

**Адрес:** 198099, г. Санкт-Петербург, ул. Калинина, дом 2, корпус 4, литера А.