

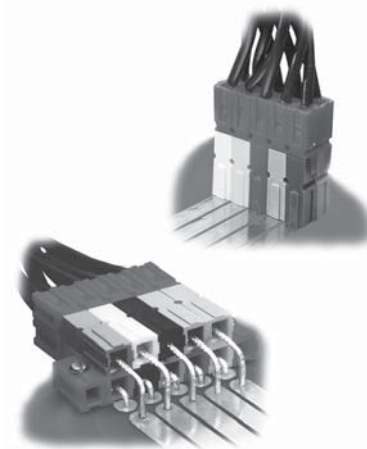

Anderson Power Products® printed circuit board (PCB) contact series, when utilized with the Powerpole® 15/45 connector housings, provides a reliable wire to printed circuit board connection. They are rated at 25 amps, 600 volts, AC/DC. This contact is available in both straight and right angle terminations for perpendicular and parallel mounting and is ideal for all applications that require high current connections to the PCB.

FEATURES

- **Straight & right angle terminals**
Flexibility of parallel or perpendicular mounting to the PCB
- **Tin plated copper contacts**
Minimal contact resistance at high currents
- **Fits standard housing & accessories**
Allows for configurations that can be color coded & polarized
- **Two level right angle contacts**
Dual level right angle powerpole assemblies provide high power density



PRODUCT SPECIFICATIONS

Connector Model	25A PCB	PCB traces	See temperature curve or contact the factory
Current rating for a single mated pair	25 amps *	Housing material	Polycarbonate 94 V-0(Max. op. temp. = 105°C / 221°F)
Maximum operating voltage AC/DC	600 volts		Operating temp. = ambient temp. + temp. rise at current
Contact material	Tin plated copper alloy	 * See Temperature Rise Chart. Based on 0.002 in ² copper foil on PCB & 12AWG wire cross-section.	
PCB hole (inches)	.070 hole		
PCB hole (mm)	1.80		

ORDERING INFORMATION

25 amp Right Angle PCB Contact*

Part Number	Description	Contact Length in.	sq. mm
1377G1	Right Angle - LD	0.70	17.8
1377G2	Right Angle - LD	0.40	10.2
1377G11	Right Angle - LD	0.70	17.8
1377G12	Right Angle - LD	0.40	10.2
1377G14	Right Angle - LD	0.18	4.6
1377G15	Right Angle - LD	1.02	25.9
1377G16	Right Angle - LD	0.72	18.3
1377G17	Right Angle - LD	0.88	22.4
1377G18	Right Angle - LD	0.58	14.7
1317G1	Right Angle - HD	0.70	17.8
1317G2	Right Angle - HD	0.40	10.2
1317G11	Right Angle - HD	0.70	17.8
1317G14	Right Angle - HD	0.18	4.6
1317G15	Right Angle - HD	1.02	25.9
1317G16	Right Angle - HD	0.72	18.3
1317G17	Right Angle - HD	0.88	22.4
1317G18	Right Angle - HD	0.58	14.7

25 amp Straight PCB Contact*

Part Number	Description	Contact Length in.	sq. mm
1377G3	Straight Terminal - LD	2.16	54.9
1377G4	Straight Terminal - LD	1.7	43.2
1377G13	Straight Terminal - LD	1.11	28.2
1317G3	Straight Terminal - HD	2.16	54.9
1317G4	Straight Terminal - HD	2.16	43.2
1317G13	Straight Terminal - HD	1.11	28.2

Housings Only

Part Number	Description
1327	Red housing
1327G5	Green housing
1327G6	Black housing
1327G7	White housing
1327G8	Blue housing
1327G16	Yellow housing

housings only continued

Part Number	Description
1327G17	Orange housing
1327G18	Gray housing
1327G21	Brown housing
1327G22	Pink housing
1327G23	Purple housing

Accessories

Part Number	Description
1399G9	Red mounting wing
1399G8	Blue mounting wing
1399G1**	Red short spacer with end hole
1399G2**	Red long spacer
1399G6**	Red short spacer without hole
110G68	PP15/45 retention clip
114555P1	Staple 1x1 (H x W)
114555P2	Staple 1x2 (H x W)
114555P3	Staple 1x3 (H x W)
114555P7	Staple 1x4 (H x W)
114555P8	Staple 1x6 (H x W)
114555P5	Staple 2x1 (H x W)
114555P6	Staple 2x2 (H x W)
114555P9	Staple 2x2 - long (H x W)

* LD - low detent or HD - high detent

** Contact customer service for additional colors

Note: For additional colors please contact customer service.

HEADQUARTERS: 13 Pratts Junction Road, P.O. Box 579, Sterling, MA 01564 T:978-422-3600 F:978-422-3700

EUROPE: Rathely Road, Fermoy Co. Cork, Ireland T:353-(0)25-32277 F:353-(0)25-32296

ASIA/PACIFIC: IDEAL Anderson Asia Pacific Ltd., Unit 922-928 Topsail Plaza, 11 On Sum Street, Shatin N.T., Hong Kong T:852-2636-0836 F:852-2635-9036

CHINA: IDEAL Anderson Technologies (Shenzhen) Ltd., Block A8 Tantou W. Ind. Par, Songgang Baoan District, Shenzhen, P.R. China 51810 T: 86-755-2768-2118 F: 86-755-2768-2218

TAIWAN: IDEAL Anderson Asia Pacific Ltd., Taiwan Branch, 4F-2, No.116, Dadun 20th St., Situn District, Taichung City 407, Taiwan (R.O.C.) T: 886-4-2310-6451 F:886-4-2310-6460

www.andersonpower.com

DIMENSIONS

Straight Terminals

Part Number	-C-		-E-	
	mm	in.	mm	in.
1377G3	54.9	2.16	56.4	2.22
1377G4	43.2	1.70	44.7	1.76
1317G3	54.9	2.16	56.4	2.22
1317G4	43.2	2.16	44.7	1.76
1377G13	28.2	1.11	29.7	1.17
1317G13	28.2	1.11	29.7	1.17

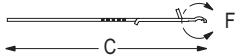

Low Detent Contact, Straight Terminal

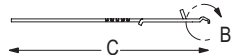

High Detent Contact, Straight Terminal

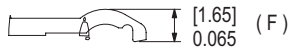

Low Detent Contact, Bent or Straight



High Detent Contact, Bent or Straight

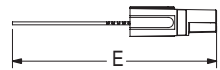

Straight Terminal Inside a Housing

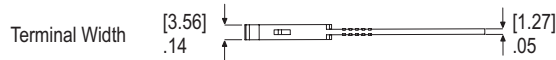

PCB Center Line

-A-	-B-	-C-	-D-	-E-	-F-	-G-	
mm	in.	mm	in.	mm	in.	mm	in.
7.9	.31	7.9	.31	24.7	.97	8.4	.33
				16.3	.64	34.5	1.36
						13.7	.54

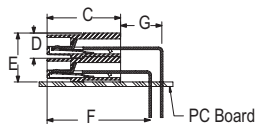
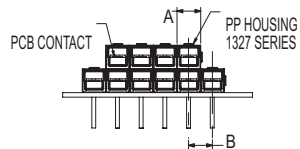

Housing

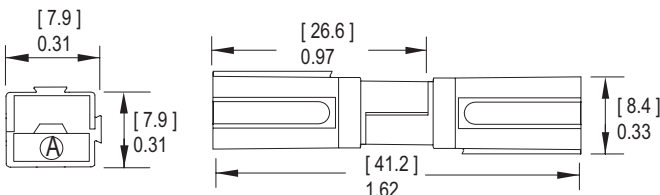

TEMPERATURE RISE CHART

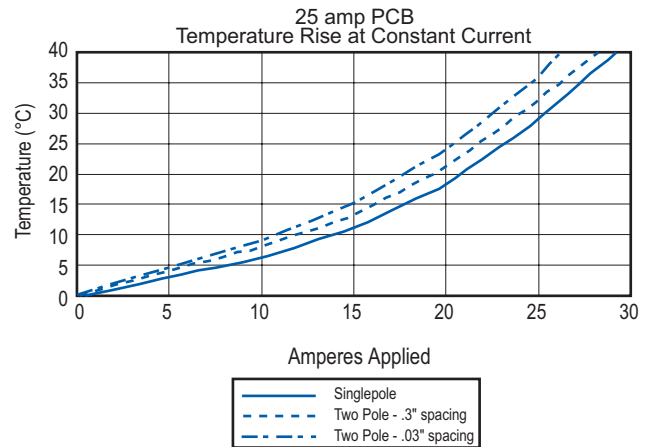

Note: Based on 0.002 in² copper foil on PCB & 12AWG wire cross-section.

Right Angle Contacts

Part Number	-A-		-B-		-D-	
	mm	in.	mm	in.	mm	in.
1377G1	36.8	1.46	17.8	0.70	38.6	1.52
1377G2	33.0	1.30	10.2	0.40	34.5	1.36
1377G11	29.0	1.14	17.8	0.70	30.7	1.21
1377G12	24.2	0.95	10.2	0.40	25.7	1.01
1377G14	33.0	1.30	4.6	0.18	34.5	1.36
1377G15	29.0	1.14	25.9	1.02	30.7	1.21
1377G16	24.1	0.95	18.3	0.72	25.4	1.00
1377G17	29.0	1.14	22.4	0.88	30.7	1.21
1377G18	25.4	1.00	14.7	0.58	27.2	1.07
1317G1	36.8	1.46	17.8	0.70	38.6	1.52
1317G2	33.0	1.30	10.2	0.40	34.5	1.36
1317G11	29.0	1.14	17.8	0.70	30.7	1.21
1317G14	33.0	1.30	4.6	0.18	34.5	1.36
1317G15	29.0	1.14	25.9	1.02	30.7	1.21
1317G16	24.1	0.95	18.3	0.72	25.4	1.00
1317G17	29.0	1.14	22.4	0.88	30.7	1.21
1317G18	25.4	1.00	14.7	0.58	27.2	1.07

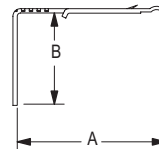

Right Angle Contact Without a Housing

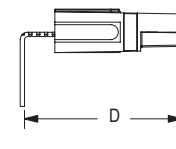

Right Angle Contact With a Housing

Staple

Part Number	H x W	-A-		-B-	
		mm	in.	mm	in.
114555P1	1x1	12.0	0.472	6.0	0.236
114555P2	1x2	12.0	0.472	13.5	0.531
114555P3	1x3	12.0	0.472	21.5	0.846
114555P7	1x4	12.0	0.472	29.5	1.161
114555P8	1x6	12.0	0.472	45.5	1.791
114555P5	2x1	20.0	0.787	6.0	0.236
114555P6	2x2	20.0	0.787	13.5	0.531
114555P9	2x2 (long)	23.0	0.905	13.5	0.531

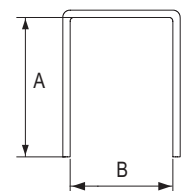

Anderson Power Products High Current printed circuit board (PCB) contact series, when utilized with the Powerpole® 15/45 connector housings, provides a reliable wire to PCB connection. They are UL Recognized at 45 amps, AC or DC. The connector may be configured in 1 and 2 row configurations, in both vertical and right angle mounted terminations. This connector provides an ideal solution for applications that require high current connections to a PCB.

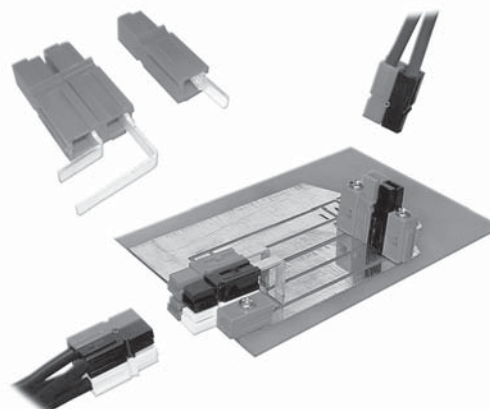

FEATURES

- **Current rating 45 amps**
Enables high current connections directly to the PCB
- **Vertical and right angle terminations**
Allows for design flexibility
- **High durability**
 - Rated up to 1,500 cycles (no load)
 - Under Load (Hot Plug 250 cycles @ 120V)
- **Offered in pre-assembled 1 and 2 row configurations (See Ordering Information)**
 - Reduces assembly costs of housings and contacts
 - Pre-assembled configurations prevent accidental separation of housings
- **Individual housings and contacts also sold separately**
 - Allows for customization of configurations
 - Allows for color coding of housings to wires for ease of manufacturing

PRODUCT SPECIFICATIONS

UL Current Rating For Single Mated Pair	45 amps (for others see rating curves)*	PCB Thickness - in. [mm]	0.093 [2.4] - 0.125 [3.2]
Max Recommended Voltage - (per IEC 60950-1)	150V (pollution degree 3) - 250V (pollution degree 2)	Contact Material	Tin plating copper alloy
Minimum Creepage	2.8mm	Housing Material	Polycarbonate 94 V-0 rated
Voltage Drop For Mated Pair	≤ 2.50 mV		
Connector Mating Force For Mated Pair	2 - 3 Lbf.		
PCB Footprint	See following page		



* See Temperature Rise Chart

ORDERING INFORMATION

High Power Connector

Part Number	Description
PP45PC12S	1x2 vertical mount, short tail, black housing
PP45PC13S	1x3 vertical mount, short tail, black housing
PP45PC12R	1x2 horizontal, single row, right angle tail, black housing
PP45PC13R	1x3 horizontal, single row, right angle tail, black housing
PP45PC21R	2x1 horizontal, dual row, right angle tail, black housing
PP45PC22R	2x2 horizontal, dual row, right angle tail, black housing
PP45PC23R	2x3 horizontal, dual row, right angle tail, black housing

High Power Contact

Part Number	Description
1335G1	Vertical mount, short tail contact
1336G1	Horizontal (Bottom), right angle mount
1337G1	Horizontal (Top), right angle mount

Housings Only

Part Number	Description
1327	Red housing
1327G5	Green housing
1327G6	Black housing
1327G7	White housing
1327G8	Blue housing
1327G16	Yellow housing
1327G17	Orange housing
1327G18	Gray housing
1327G21	Brown housing
1327G22	Pink housing
1327G23	Purple housing

Accessories

Part Number	Description
1399G9	Red mounting wing
1399G8	Blue mounting wing
1399G1	Red short spacer with end hole
1399G2	Red long spacer
1399G6	Red short spacer without hole
110G68	PP15/45 retention clip
114555P1	Staple 1x1 (H x W)
114555P2	Staple 1x2 (H x W)
114555P3	Staple 1x3 (H x W)
114555P7	Staple 1x4 (H x W)
114555P8	Staple 1x6 (H x W)
114555P5	Staple 2x1 (H x W)
114555P6	Staple 2x2 (H x W)
114555P9	Staple 2x2 - long (H x W)

Note: For additional colors please contact customer service. For finger proof housings see page 18.

HEADQUARTERS: 13 Pratts Junction Road, P.O. Box 579, Sterling, MA 01564 T:978-422-3600 F:978-422-3700

EUROPE: Rathealy Road, Fermoy Co. Cork, Ireland T:353-(0)25-32277 F:353-(0)25-32296

ASIA/PACIFIC: IDEAL Anderson Asia Pacific Ltd., Unit 922-928 Topsail Plaza, 11 On Sum Street, Shatin N.T., Hong Kong T:852-2636-0836 F:852-2635-9036

CHINA: IDEAL Anderson Technologies (Shenzhen) Ltd., Block A8 Tantou W. Ind. Par, Songgang Baoan District, Shenzhen, PR. China 51810 T: 86-755-2768-2118 F: 86-755-2768-2218

TAIWAN: IDEAL Anderson Asia Pacific Ltd., Taiwan Branch, 4F.-2, No.116, Dadun 20th St., Situn District, Taichung City 407, Taiwan (R.O.C.) T: 886-4-2310-6451 F:886-4-2310-6460

www.andersonpower.com

DIMENSIONS

Straight Terminal

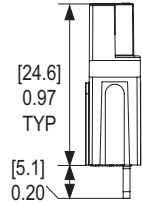

Right Angle Terminal

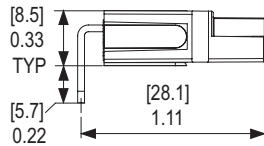

Right Angle Terminal 2 High

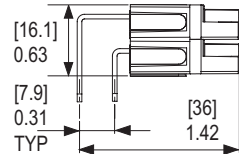

Typical Contact Orientation

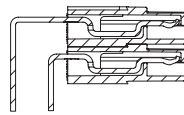

Blocked Housings 2 x 2

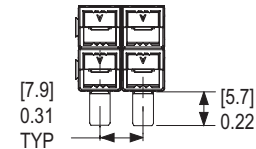

Footprint

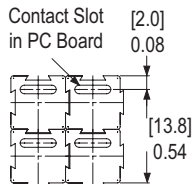

Multipole Vertical Mount Connector Typical Placement

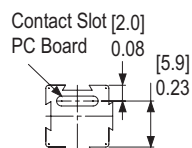

Singlepole Vertical Mount Connector Typical Placement

Staple

Part Number	H x W	- A - mm in.	- B - mm in.
114555P1	1x1	12.0 0.472	6.0 0.236
114555P2	1x2	12.0 0.472	13.5 0.531
114555P3	1x3	12.0 0.472	21.5 0.846
114555P7	1x4	12.0 0.472	29.5 1.161
114555P8	1x6	12.0 0.472	45.5 1.791
114555P5	2x1	20.0 0.787	6.0 0.236
114555P6	2x2	20.0 0.787	13.5 0.531
114555P9	2x2 (long)	23.0 0.905	13.5 0.531

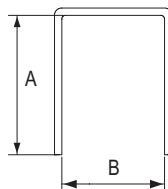

TEMPERATURE RISE CHART

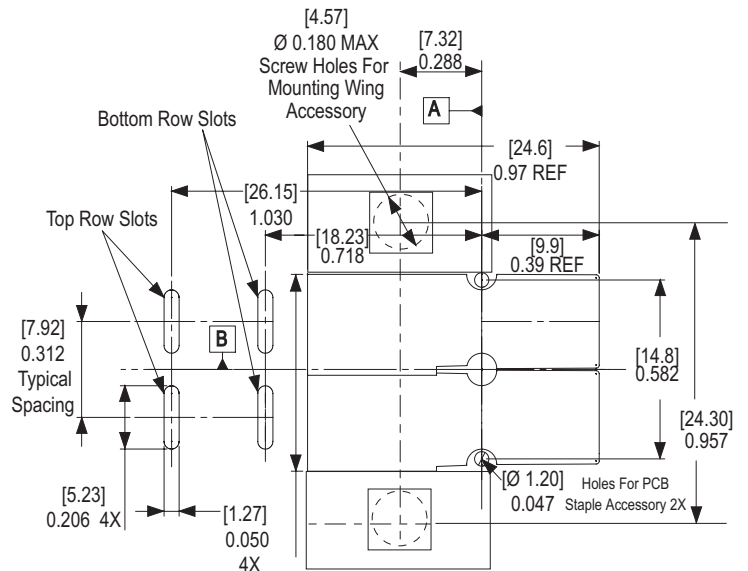
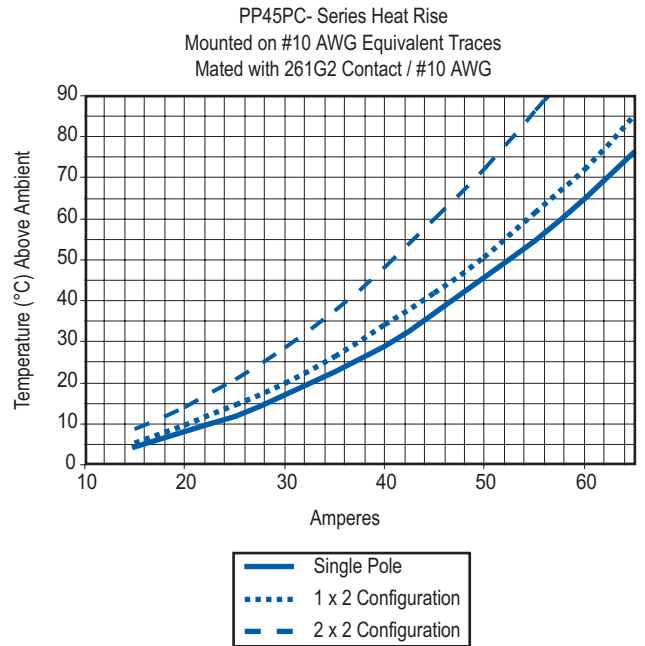

The innovative design of our Powerclaw® family of connectors for the power electronics market makes connecting and disconnecting a snap, enabling safe and convenient "hot swapping" during equipment maintenance without the need to power down. Compact and robust, they're rated at 55 amps for single pole and 50 amps for multipole connections.

Our mini horizontal and vertical Powerclaw contacts offer the same high current capacity as our original Powerclaws while providing the design engineer more options when board real estate is at a minimum.

* Contact factory for ratings

FEATURES

- **Quick disconnect**
Avoids the need for unfastening ring type terminals
- **Snap-On interface**
Ensures foolproof assembly and proper connection
- **Vertical mini-powerclaw UL rated**
For current interruption (hot-plug) so that equipment can be hot swapped
- **Anti-static packaging**
Meets electronics industry PCB requirements
- **Vacuum packaging**
Prevents tarnishing of contacts during shelf life

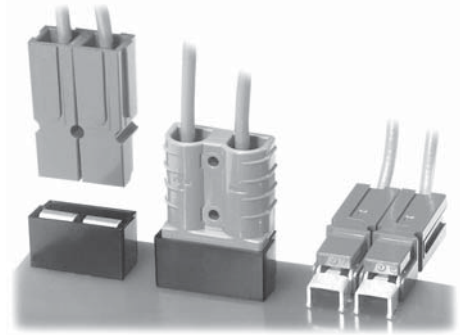

PRODUCT SPECIFICATIONS

Product Information	PP Powerclaw	SB® Powerclaw Powerclaw	Locking Mini-Powerclaw	Vertical & Horizontal
Maximum Current* (per Tin Contact)	55 amps	50 amps	55 amps	55 amps
Maximum Voltage (AC or DC)	600 volts	600 volts	600 volts	600 volts
Housing Material	Polycarbonate	Polycarbonate	Polycarbonate	Polycarbonate for vertical guide housings
Contact Material	Copper Alloy	Copper Alloy	Copper Alloy	Copper Alloy
Contact Plating: Tin	100 microinches Sn over 50 microinches Ni	100 microinches Sn over 50 microinches Ni	100 microinches Sn over 50 microinches Ni	100 microinches Sn over 50 microinches Ni
Contact Plating: Silver	100 microinches Ag over 50 microinches Ni	100 microinches Ag over 50 microinches Ni	100 microinches Ag over 50 microinches Ni	100 microinches Ag over 50 microinches Ni
Mating/Unmating Forces	7 lbf. Average (31 Newtons)	15 lbf. Average (66 Newtons)	7 lbf. Average (31 Newtons)	4 lbf. per contact (17 Newtons)
Suggested Board Thickness	.150" max.	.150" max.	.150" max.	.250" max.

* See Temperature Rise Chart

High Power PCB Contacts		High Power PCB Contacts	
Test Condition	Specification Tested to and Met:	Test Condition	Specification Tested to and Met:
Mechanical		Environmental	
Sine Vibration	MIL-STD-1344, Method 2005, Test Condition I.	Temperature Cycling	MIL-STD-1344, Method 1003, Test Condition A.
Mechanical Shock	MIL-STD-1344, Method 2004, Test Condition I.	Humidity	MIL-STD-1344, Method 3001, Type 1.
Mating Force	APP Specification, 7 lbf. average mating force.	Flammability	
Durability	10,000 cycles, APP Specification	PP-, LP-, SB-series	UL94 V-0
Electrical			
Temperature Rise at rated current	UL1977		
Dielectric Voltage	MIL-STD-1344, Method 3001, Type 1.		
Withstand	Type 1.		
Contact Resistance	MIL-STD-1344, Method 3004, Type 1		



HEADQUARTERS: 13 Pratts Junction Road, P.O. Box 579, Sterling, MA 01564 T:978-422-3600 F:978-422-3700

EUROPE: Rathealy Road, Fermoy Co. Cork, Ireland T:353-(0)25-32277 F:353-(0)25-32296

ASIA/PACIFIC: IDEAL Anderson Asia Pacific Ltd., Unit 922-928 Topsail Plaza, 11 On Sum Street, Shatin N.T., Hong Kong T:852-2636-0836 F:852-2635-9036

CHINA: IDEAL Anderson Technologies (Shenzhen) Ltd., Block A8 Tantou W. Ind. Par, Songgang Baoan District, Shenzhen, P.R. China 51810 T: 86-755-2768-2118 F: 86-755-2768-2218

TAIWAN: IDEAL Anderson Asia Pacific Ltd., Taiwan Branch, 4F.-2, No.116, Dadun 20th St., Situn District, Taichung City 407, Taiwan (R.O.C.) T: 886-4-2310-6451 F:886-4-2310-6460

www.andersonpower.com

ORDERING INFORMATION

Standard Powerclaw

Position Definition	PC	XXX	X	XX
	(Powerclaw)	(Color)	(Plating)	(Housing)
		BLK-Black	T-Tin	PP-Powerpole 75
		RED-Red	S-Silver	LP-Locking Powerpole 75
		BLU-Blue		SB-SB50
		WHT-White		
		GRA-Gray		
		GRN-Green		

Example: Blue 75 locking Powerclaw with tin plating (PC-BLU-T-LP)

Note: For additional colors please contact customer service

Individual Contacts and Guide Housings*

Part No.	Description
PC5930S	Std PC horizontal mount contact – Silver (Ag)
PC5930T	Std PC horizontal mount contact – Tin (Sn)
PC5933T	Mini-PC vertical contact – Tin (Sn)
PC5933S	Mini-PC vertical contact – Silver (Ag)
PC5934T	Mini-PC horizontal contact – Tin (Sn)
PC5934S	Mini-PC horizontal contact – Silver (Ag)
PC-HSG-SB	Guide housing for SB50 (Black)
PC-HSG-PP	Guide housing for PP75 (Black)

* For non-ESD bulk packaged product, add -BK to part number when ordering.

Packaging Quantity

APP's Powerclaw® contacts and connectors are packaged in ESD plastic and foam. This prevents our contacts and connectors from carrying any electrostatic charge that could damage ICs and other sensitive components on a PC board during assembly. The vacuum-sealed package also prevents tarnishing or adverse environmental reactions to occur on the contact. Contacts and housings are also available in bulk quantities, packaged in non-ESD cartons.

Packaging	Quantity
PP Powerclaw	20 per bag
Locking PP Powerclaw	20 per bag
SB Powerclaw	10 per bag
Mini-Powerclaw contacts	20 per bag
Guide Housings	10 per bag or bulk

TEMPERATURE RISE CHART

Temperature Rise at Constant Currents

Powerclaw® Tested in Accordance with EIA 364-70, No enclosure, 25+/-5 deg. C. ambient (#8 AWG Foil on Board Side, #6 AWG conductor on wire side, Contact Cat. No. 5900). Temperature Rise of Contact at exit from Housing Interface (No Air Flow over Test Loop).

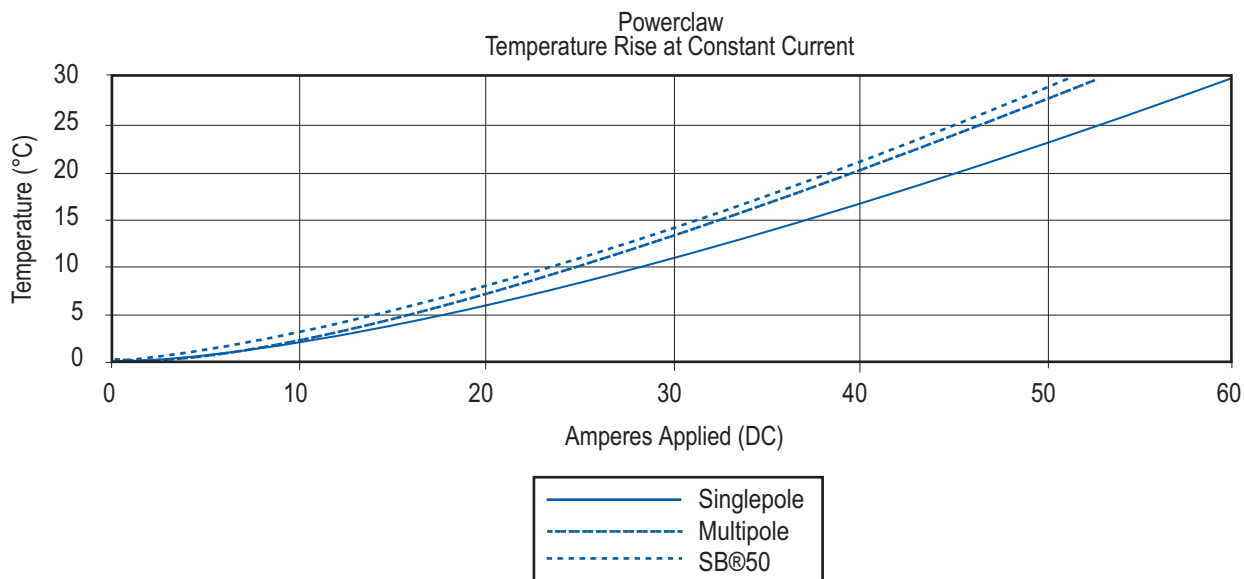

HEADQUARTERS: 13 Pratts Junction Road, P.O. Box 579, Sterling, MA 01564 T:978-422-3600 F:978-422-3700

EUROPE: Rathealy Road, Fermoy Co. Cork, Ireland T:353-(0)25-32277 F:353-(0)25-32296

ASIA/PACIFIC: IDEAL Anderson Asia Pacific Ltd., Unit 922-928 Topsail Plaza, 11 On Sum Street, Shatin N.T., Hong Kong T:852-2636-0836 F:852-2635-9036

CHINA: IDEAL Anderson Technologies (Shenzhen) Ltd., Block A8 Tantou W. Ind. Par, Songgang Baoan District, Shenzhen, P.R. China 51810 T: 86-755-2768-2118 F: 86-755-2768-2218

TAIWAN: IDEAL Anderson Asia Pacific Ltd., Taiwan Branch, 4F.-2, No.116, Dadun 20th St., Situn District, Taichung City 407, Taiwan (R.O.C.) T: 886-4-2310-6451 F:886-4-2310-6460

www.andersonpower.com

STANDARD POWERCLAW DIMENSIONS

Standard Powerclaw with locking PP75

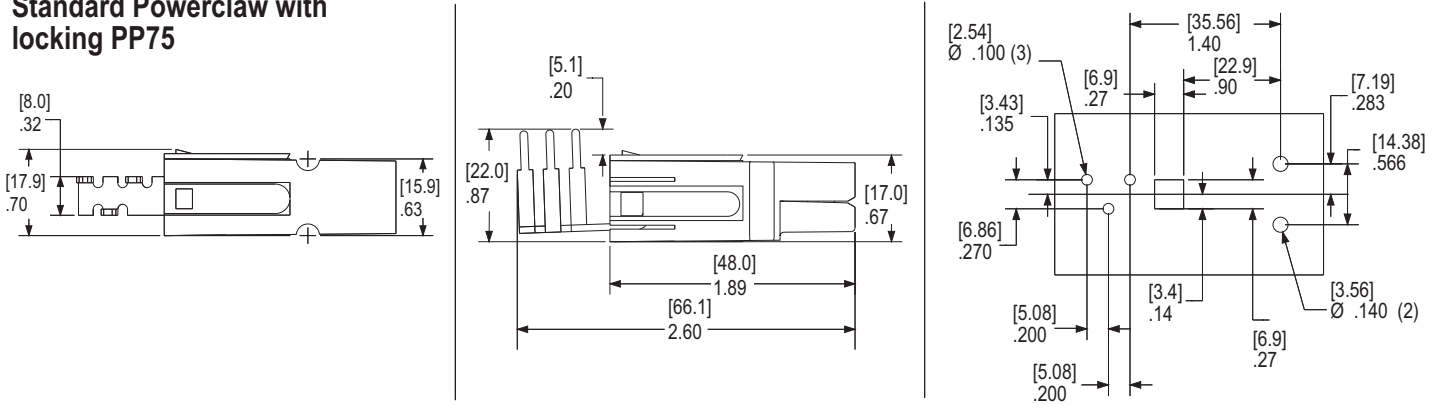

Standard Powerclaw with PP75

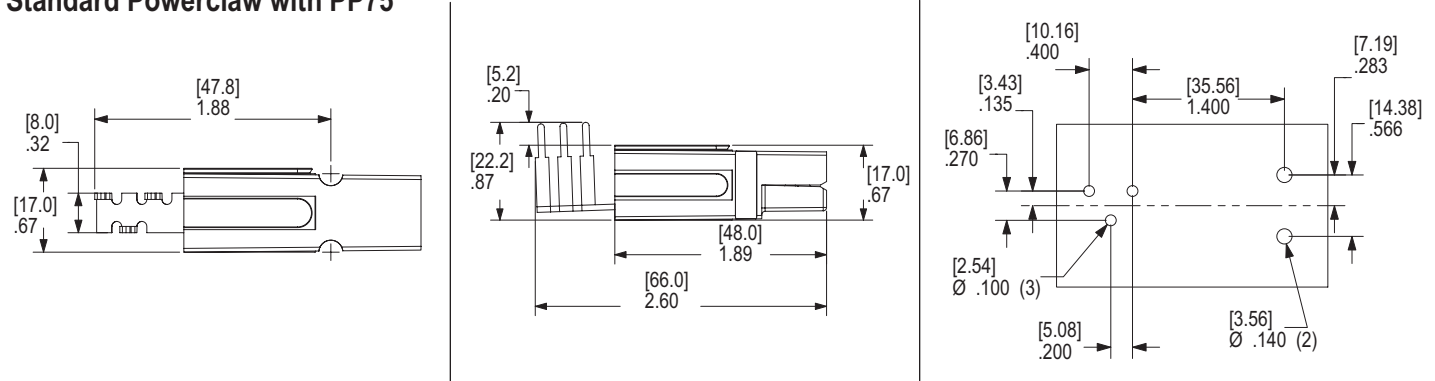

Standard Powerclaw with SB®50

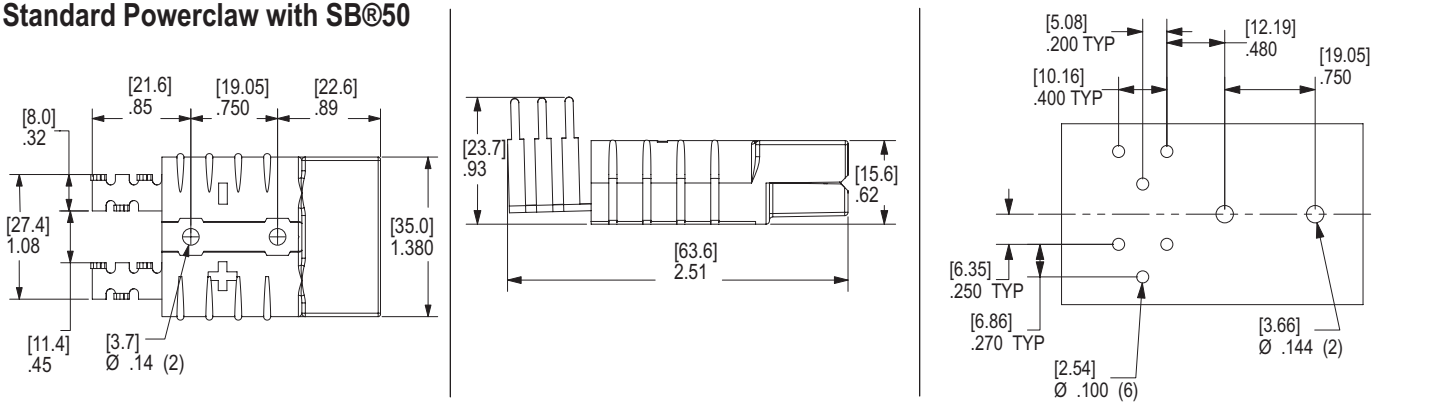

Staple for single powerpole

Part Number: PCSTAPLE-1

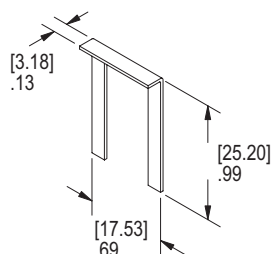

Staple for double powerpole

Part Number: PCSTAPLE-2

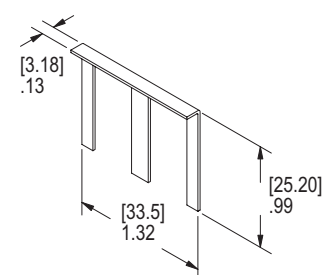

HEADQUARTERS: 13 Pratts Junction Road, P.O. Box 579, Sterling, MA 01564 T:978-422-3600 F:978-422-3700

EUROPE: Rathealy Road, Fermoy Co. Cork, Ireland T:353-(0)25-32277 F:353-(0)25-32296

ASIA/PACIFIC: IDEAL Anderson Asia Pacific Ltd., Unit 922-928 Topsail Plaza, 11 On Sum Street, Shatin N.T., Hong Kong T:852-2636-0836 F:852-2635-9036

CHINA: IDEAL Anderson Technologies (Shenzhen) Ltd., Block A8 Tantou W. Ind. Par, Songgang Baoan District, Shenzhen, P.R. China 51810 T: 86-755-2768-2118 F: 86-755-2768-2218

TAIWAN: IDEAL Anderson Asia Pacific Ltd., Taiwan Branch, 4F.-2, No.116, Dadun 20th St., Situn District, Taichung City 407, Taiwan (R.O.C.) T: 886-4-2310-6451 F:886-4-2310-6460

MINI-POWERCLAW DIMENSIONS

Vertical Powerclaw

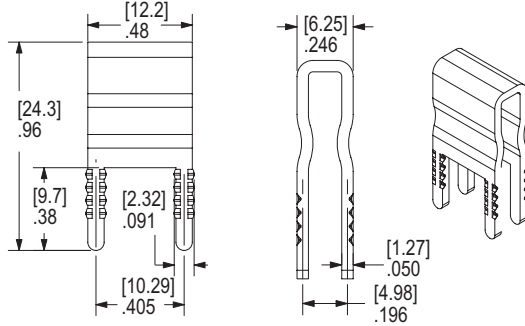

Horizontal Powerclaw

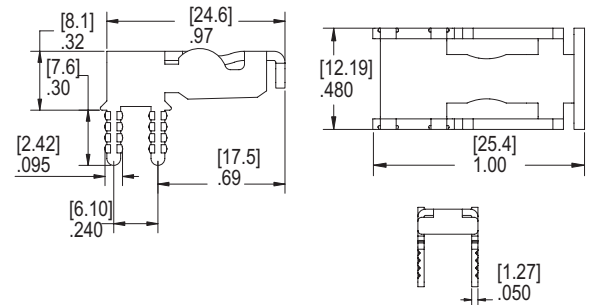

Vertical PCB Placement - Hole Configuration (with or without housing)

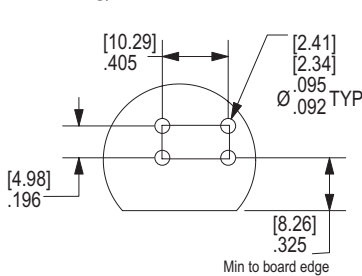

Vertical Contact With Single PP75 Guide Housing NOT Required

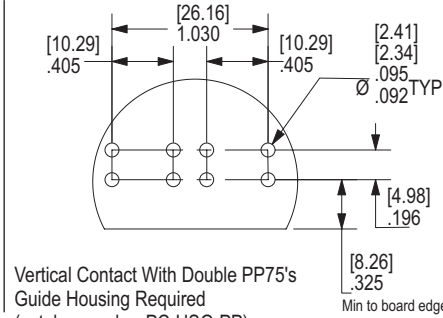

Vertical Contact With Double PP75's Guide Housing Required (catalog number PC-HSG-PP)

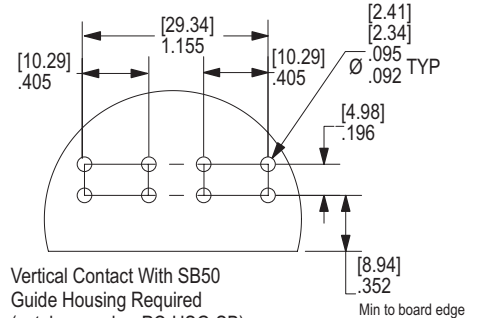

Vertical Contact With SB50 Guide Housing Required (catalog number PC-HSG-SB)

Horizontal PCB Placement - Hole Configuration

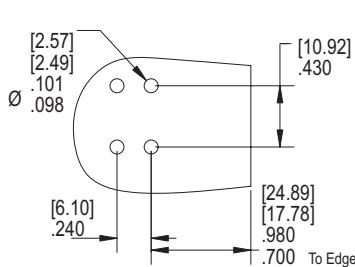

PCB Hole Layout for Singlepole Powerpole

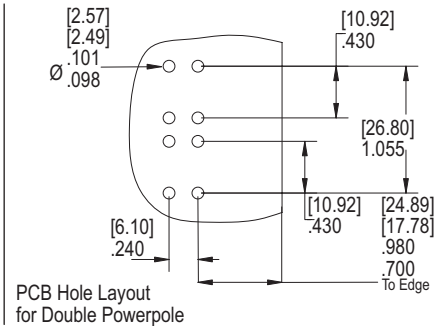

PCB Hole Layout for Double Powerpole

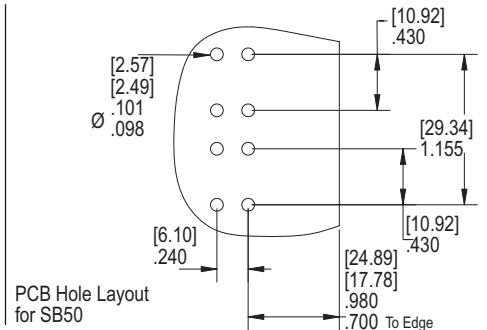

PCB Hole Layout for SB50

Mated Horizontal Contacts (board attachment)

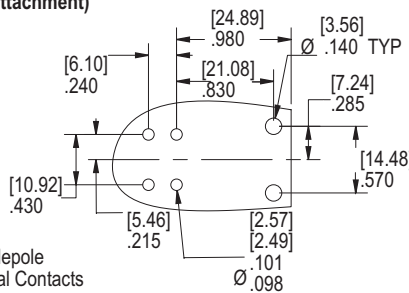

For Singlepole Horizontal Contacts

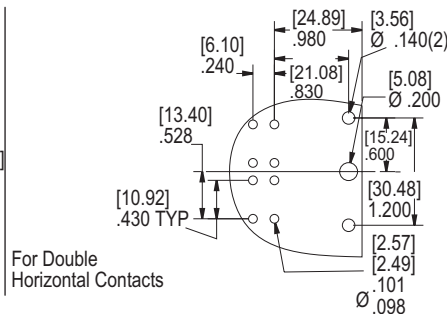

For Double Horizontal Contacts

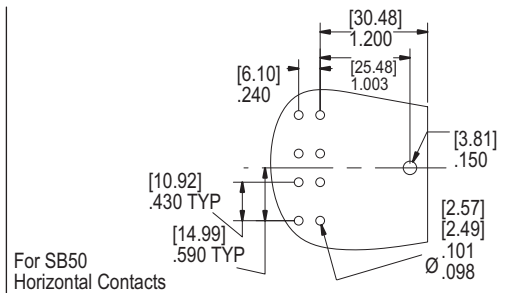

For SB50 Horizontal Contacts



Компания «ЭлектроПласт» предлагает заключение долгосрочных отношений при поставках импортных электронных компонентов на взаимовыгодных условиях!

Наши преимущества:

- Оперативные поставки широкого спектра электронных компонентов отечественного и импортного производства напрямую от производителей и с крупнейших мировых складов;
- Поставка более 17-ти миллионов наименований электронных компонентов;
- Поставка сложных, дефицитных, либо снятых с производства позиций;
- Оперативные сроки поставки под заказ (от 5 рабочих дней);
- Экспресс доставка в любую точку России;
- Техническая поддержка проекта, помощь в подборе аналогов, поставка прототипов;
- Система менеджмента качества сертифицирована по Международному стандарту ISO 9001;
- Лицензия ФСБ на осуществление работ с использованием сведений, составляющих государственную тайну;
- Поставка специализированных компонентов (Xilinx, Altera, Analog Devices, Intersil, Interpoint, Microsemi, Aeroflex, Peregrine, Syfer, Eurofarad, Texas Instrument, Miteq, Cobham, E2V, MA-COM, Hittite, Mini-Circuits, General Dynamics и др.);

Помимо этого, одним из направлений компании «ЭлектроПласт» является направление «Источники питания». Мы предлагаем Вам помощь Конструкторского отдела:

- Подбор оптимального решения, техническое обоснование при выборе компонента;
- Подбор аналогов;
- Консультации по применению компонента;
- Поставка образцов и прототипов;
- Техническая поддержка проекта;
- Защита от снятия компонента с производства.



Как с нами связаться

Телефон: 8 (812) 309 58 32 (многоканальный)

Факс: 8 (812) 320-02-42

Электронная почта: org@eplast1.ru

Адрес: 198099, г. Санкт-Петербург, ул. Калинина, дом 2, корпус 4, литера А.