

System Lens Drivers

μ-step System Lens Driver for Digital Still Cameras



BU24032GW

● **General Description**

BU24032GW is a system Lens Driver that uses μ-step driving to make the configuration of the sophisticated, high precision and low noise lens driver system possible. This IC has a built-in driver for both DC motor and voice coil motor and a μ-step controller that decreases CPU power. Therefore, multifunctional lens can be applied.

● **Features**

- Built-in 6 channels Driver block
 - 1ch-5ch: Voltage control type H-bridge (Adaptable to STM 1systems)
 - 6ch: Current control type H-bridge
- Built-in 2 channels PI driving circuit
- Built-in 3 channels Waveforming circuit
- Built-in FLL digital servo circuit
- Built-in PLL circuit

● **Applications**

- Digital still cameras

● **Typical Application Circuit**

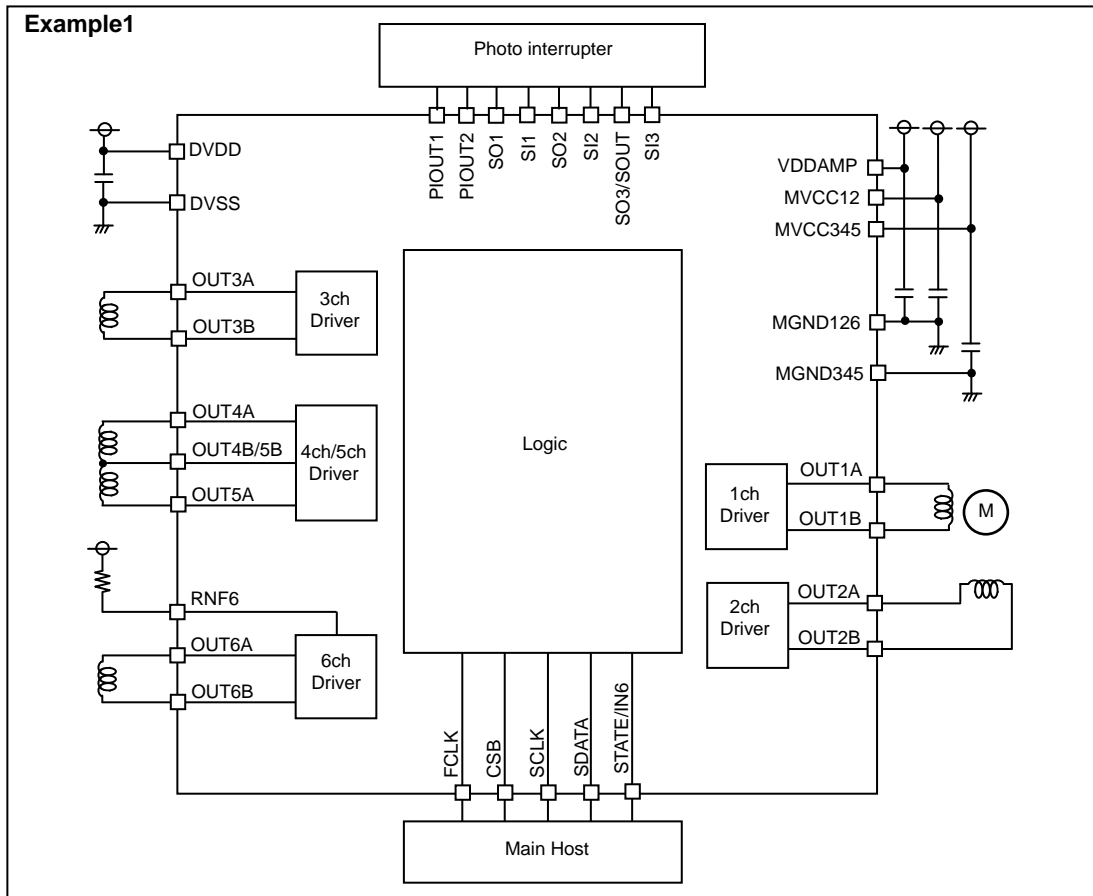

● **Key Specifications**

- Digital Power Supply Voltage: 2.7V to 3.6V
- Driver Power Supply Voltage: 2.7V to 5.5V
- Output Current (1ch-5ch): ±500mA(Max)
- Input Clock Frequency: 1MHz to 28MHz
- FET ON Resistance (1ch-5ch): 2.0Ω(Typ)
- FET ON Resistance (6ch): 1.0Ω(Typ)
- Operating Temperature Range: -20°C to +85°C

● **Package**

UCSP75M2 2.50mm x 2.50mm x 0.85mm

● Pin Configuration

(Bottom view)

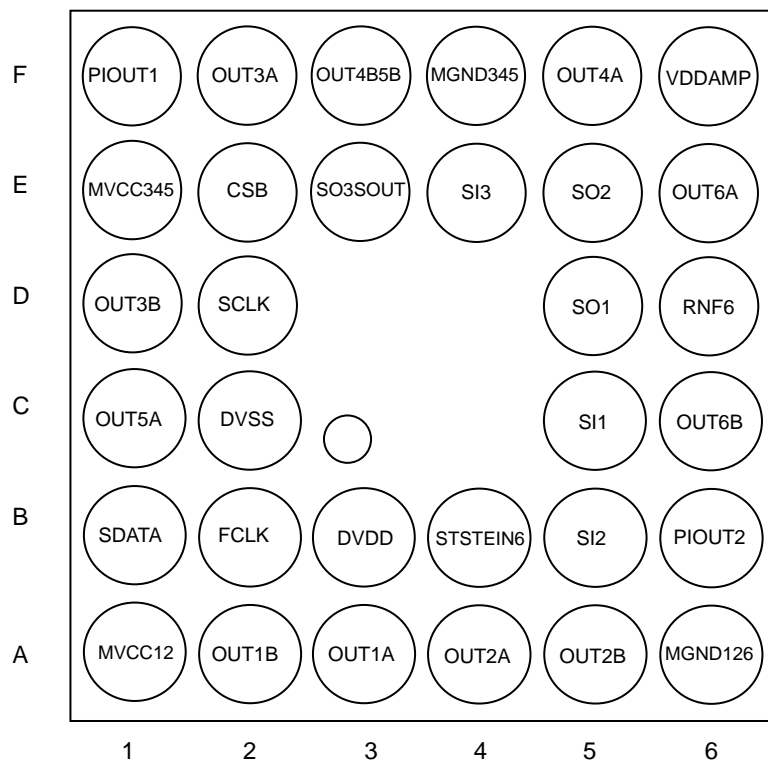

● Pin Description

Land Matrix No.	Pin Name	Power Supply	Function	Land Matrix No.	Pin Name	Power Supply	Function
B3	DVDD	-	Digital power supply	A6	MGND126	-	1ch, 2ch, 6ch Driver ground
C2	DVSS	-	ground	A3	OUT1A	MVCC12	1ch Driver A output
B2	FCLK	DVDD	FCLK logic input	A2	OUT1B	MVCC12	1ch Driver B output
E2	CSB	DVDD	CSB logic input	A4	OUT2A	MVCC12	2ch Driver A output
D2	SCLK	DVDD	SCLK logic input	A5	OUT2B	MVCC12	2ch Driver B output
B1	SDATA	DVDD	SDATA logic input	E1	MVCC345	-	3ch, 4ch, 5ch Driver power supply
B4	STATE/IN6	DVDD	STATE/IN6 logic input, output	F4	MGND345	-	3ch, 4ch, 5ch Driver ground
F1	PIOUT1	DVDD	PI driving output 1	F2	OUT3A	MVCC345	3ch Driver A output
B6	PIOUT2	VDDAMP	PI driving output 2	D1	OUT3B	MVCC345	3ch Driver B output
C5	SI1	DVDD	Waveforming input1	F5	OUT4A	MVCC345	4ch Driver A output
D5	SO1	DVDD	Waveforming output1	F3	OUT4B/5B	MVCC345	4ch/5ch Driver B output
B5	SI2	DVDD	Waveforming input2	C1	OUT5A	MVCC345	5ch Driver A output
E5	SO2	DVDD	Waveforming output2	F6	VDDAMP	-	6ch Power supply of current driver control
E4	SI3	DVDD	Waveforming input3	D6	RNF6	-	6ch Driver power supply
E3	SO3/SOUT	DVDD	Waveforming output3 / SOUT logic output	E6	OUT6A	RNF6	6ch Driver A output
A1	MVCC12	-	1ch, 2ch Driver power supply	C6	OUT6B	RNF6	6ch Driver B output

●Block Diagram

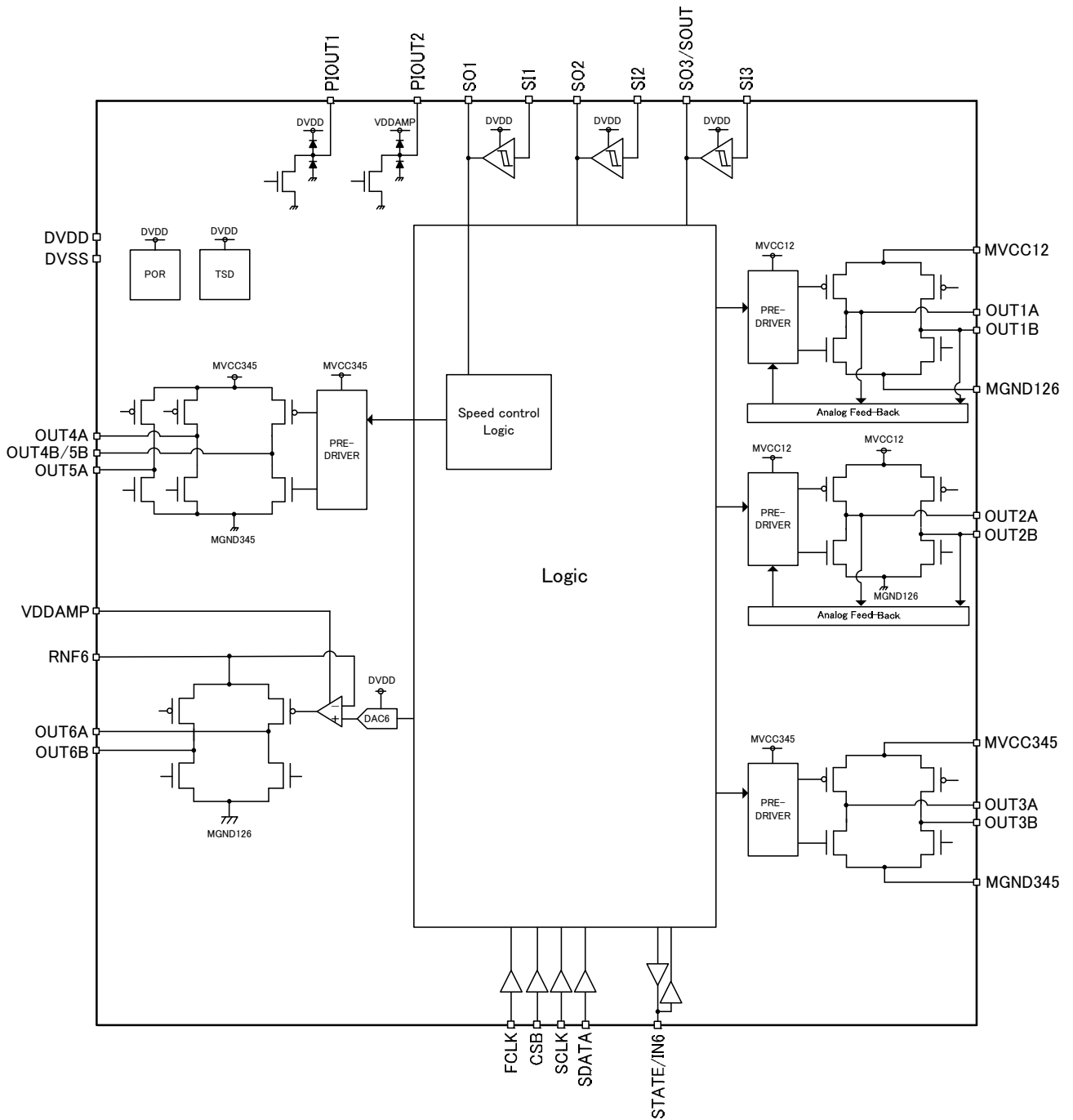

●Description of Blocks

Stepping Motor Driver (1ch, 2ch Driver)

Built-in stepping motor driver of PWM driving type.
 1 stepping motor can be driven.
 Built-in voltage feedback circuit of D-class type.

(1) Control

It corresponds to both Clock IN and Autonomous control.

(i)Clock IN Control

Set the registers for the stepping motor control.

The stepping motor is rotated and synchronized with the input clock in the STATE pin.

It is possible to select the mode of stepping motor control from μ -step, 1-2 phase excitation, 2 phase excitation and the number of edge for electrical angle cycle from 4, 8, 32, 64, 128, 256, 512 or 1024.

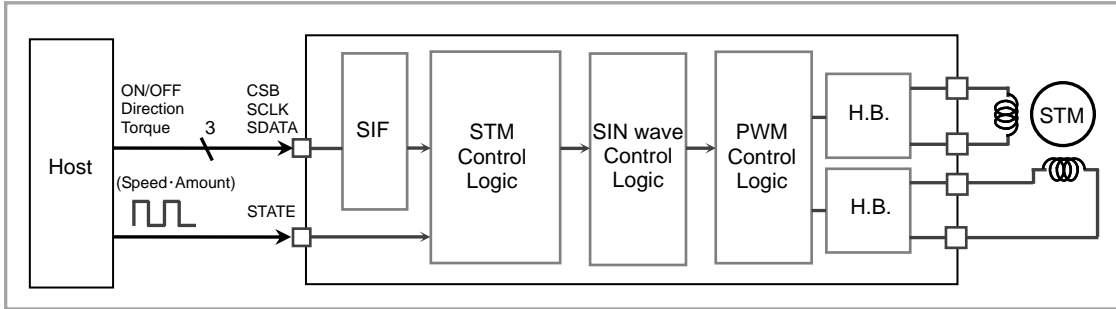

(ii)Autonomous Control

The stepping motor is rotated by setting the registers for the stepping motor control.

The state of rotation command (executing:1, finished:0), Cache register and motor position are the output from the serial output (SOUT pin). Also, the signal (MO output) which is synchronized with the motor rotation is the output from STATE pin.

It is possible to select the mode of stepping motor control from μ -step (1024 portion), 1-2 phase excitation and 2 phase excitation.

Built-in Cache registers.

Cache registers enable the setting of subsequent process while the motor is in operation. Through these registers, operations are done continuously.

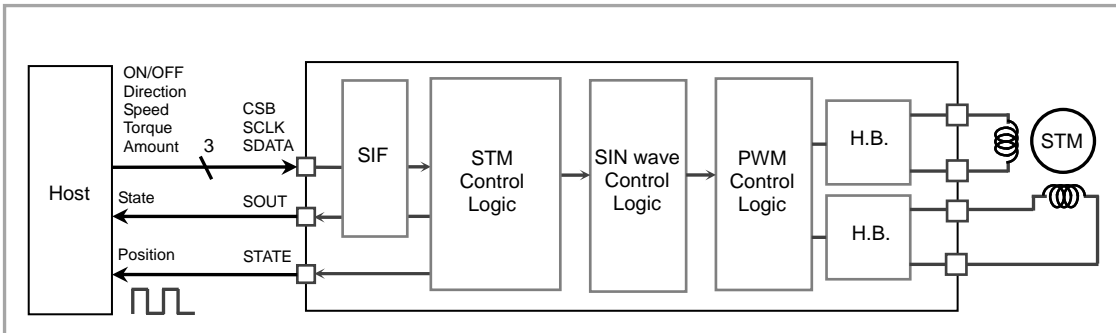

●Description of Blocks

Voltage Driver (3ch-5ch Driver)

Built-in voltage driver of PWM driving type.

4ch/5ch driver is the exclusive driver.

Built-in digital FLL speed control logic for 5ch driver.

(1)Control

(i)Register Control

■3ch Driver, 4ch Driver, 5ch Driver (at speed control = OFF)

The PWM drive is executed by the PWM duty ratio, the PWM direction and the PWM ON/OFF which are controlled by the register settings.

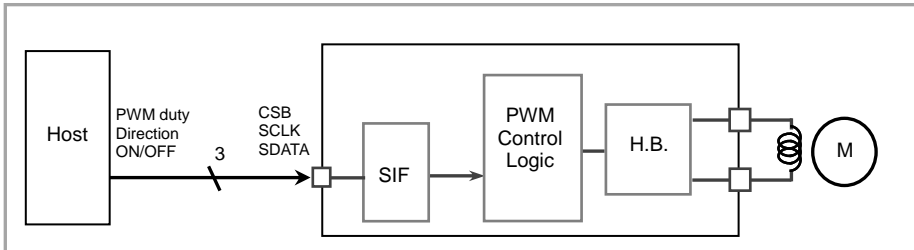

■5ch Driver (at speed control = ON)

The speed control drive is executed by the target speed value, the direction, the coefficient value of PI filter and the turning ON/OFF which are controlled by the register settings.

The motor speed is adjusted by comparing the target speed with the motor speed detected at the signal of photo-interrupter.

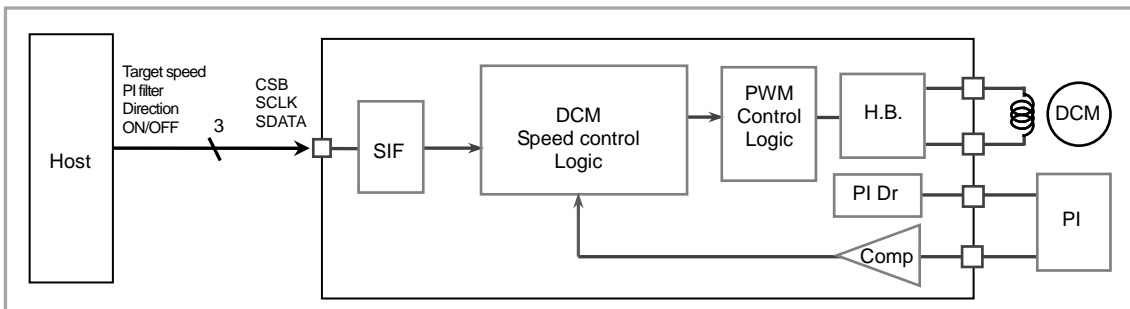

●Description of Blocks

Current Driver (6ch Driver)

Built-in constant current driver.

The voltage of RNF pin and the external resistor (RRNF) determine the amount of output current. The internal high-precision amplifier (CMOS gate input) is used for the constant current control. If any resistance component exists in the wirings of RNF pin and the external resistor (RRNF), the precision can be reduced. To avoid this, pay utmost attention to the wirings.

(1) Control

(i)Register Control

The constant current drive is executed by the output current value, the current direction and the current ON/OFF which are controlled by the register settings.

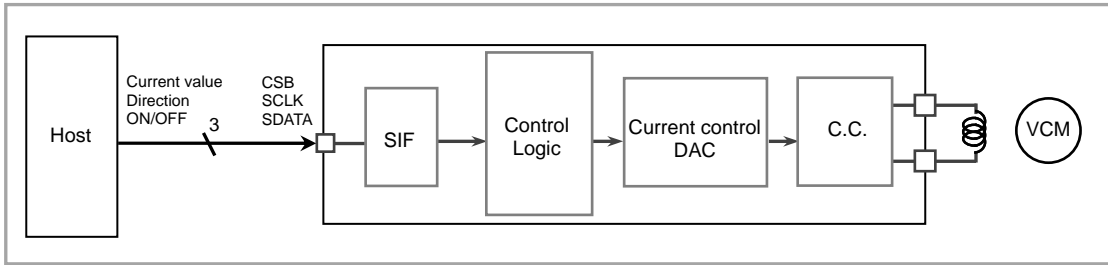

(ii)External Pin Control

The constant current drive is executed by the output current value and current direction which are controlled by the register setting. Constant current driving ON/OFF is controlled by IN6 pin.

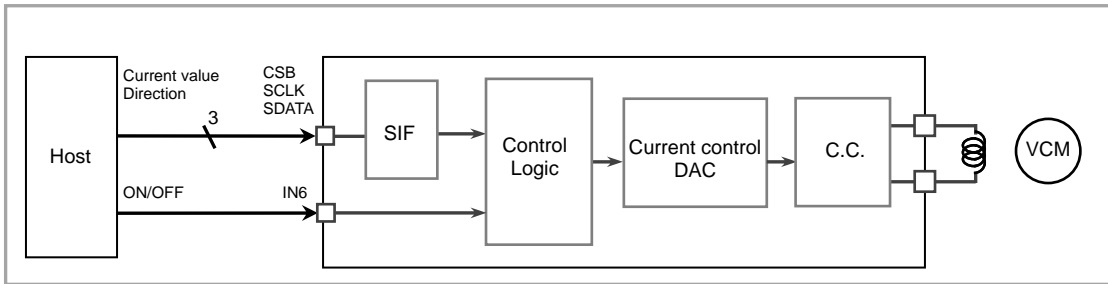

● Absolute Maximum Ratings (Ta=25°C)

Parameter	Symbol	Limit	Unit	Remark
Power Supply Voltage	DVDD	-0.3 to +4.5	V	
	MVCC	-0.3 to +7.0	V	MVCC12, MVCC345, VDDAMP
Input Voltage	VIN	-0.3 to supply voltage+0.3	V	
Input / output Current *1	IIN	±500	mA	MVCC12, MVCC345, RNF6
		+50	mA	by PIOUT pin
Storage Temperature Range	TSTG	-55 to +125	°C	
Operating Temperature Range	TOPE	-20 to +85	°C	
Permissible Dissipation *2	PD	800	mW	

*1 Must not exceed PD.

*2 To use at a temperature higher than Ta=25 °C, derate 8mW per 1 °C
(At mounting 50mm x 58mm x 1.75mm glass epoxy board.)

● Recommended Operating Rating (Ta=25°C)

Parameter	Symbol	Limit	Unit	Remark
Digital Power Supply Voltage	DVDD	2.7 to 3.6	V	DVDD ≤ MVCC
Driver Power Supply Voltage	MVCC	2.7 to 5.5	V	MVCC12, MVCC345, VDDAMP
Clock Operating Frequency	FCLK	1 to 28	MHz	Reference clock

●Electrical Characteristics

(Unless otherwise specified, Ta=25°C, DVDD=3.0V, MVCC=5.0V, DVSS=MGND=0.0V)

Parameter	Symbol	Limit			Unit	Conditions
		MIN	TYP	MAX		
<Current Consumption>						
Quiescence (DVDD)	ISSD	-	20	50	μ A	CMD_RS=0
(MVCC)	ISSM	-	0	10	μ A	
Operation (DVDD)	IDDD	-	4	8	mA	CMD_RS=STB=CLK_EN=1 FCLK=24MHz CLK_DIV setting : 0h No load
<Logic Block>						
Low-level Input Voltage	VIL	DVSS	-	0.3DVDD	V	
High-level Input Voltage	VIH	0.7DVDD	-	DVDD	V	
Low-level Input Current	IIL	0	-	10	μ A	VIL=DVSS
High-level Input Current	IIH	0	-	10	μ A	VIH=DVDD
Low-level Output Voltage	VOL	DVSS	-	0.2DVDD	V	IOL=1.0mA
High-level Output Voltage	VOH	0.8DVDD	-	DVDD	V	IOH=1.0mA
<PI Driving Circuit>						
Output Voltage	PIVO	-	0.15	0.5	V	IIH=30mA
<Waveforming Circuit>						
High-level Threshold Voltage	VthH	-	-	1.9	V	DVDD=3.25V
Low-level Threshold Voltage	VthL	0.9	-	-	V	DVDD=3.25V
Hysteresis Width	Vhys	0.2	-	0.6	V	DVDD=3.25V
<Voltage Driver Block 1ch-5ch>						
ON-resistance	Ron	-	2.0	2.5	Ω	IO=±100mA (the sum of high and low sides)
OFF-leak Current	IOZ	-10	0	+10	μ A	Output Hiz setting
Average Voltage Accuracy between different Output Pins	Vdiff	-5	-	+5	%	STM driver(1ch,2ch) Vdiff setting : 2Bh
<Current driver block 6ch>						
ON-resistance	Ron	-	1.0	1.5	Ω	IO=±100mA (the sum of high and low sides)
OFF-leak Current	IOZ	-10	0	+10	μ A	Output Hiz setting
Output Current	IO	193	200	207	mA	DAC setting : 80h RRNF=1 Ω

● Typical Performance Curves

(Unless otherwise specified, $T_a=25^\circ\text{C}$, $DVDD=3.0\text{V}$, $MVCC=5.0\text{V}$, $DVSS=MGND=0.0\text{V}$)

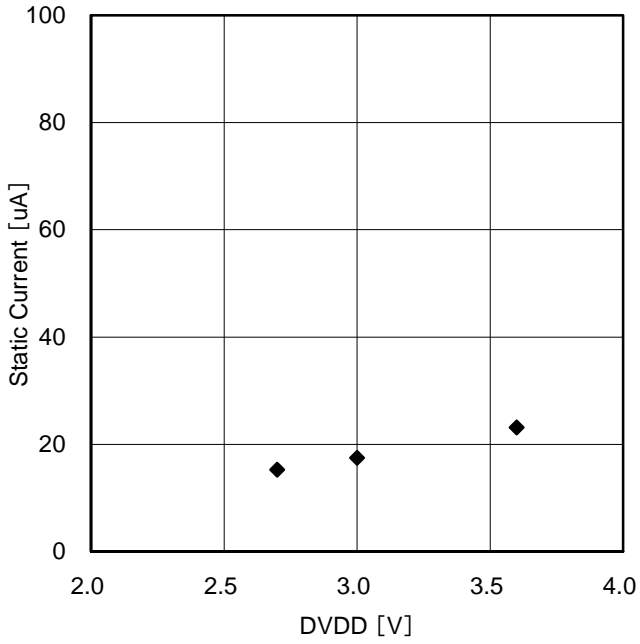

Figure 1. DVDD Static Current Voltage Dependency

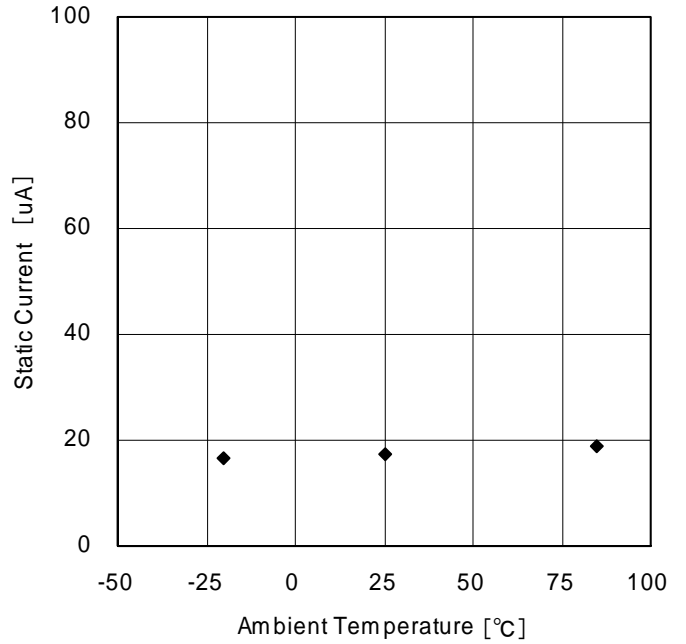

Figure 2. DVDD Static Current Temperature Dependency

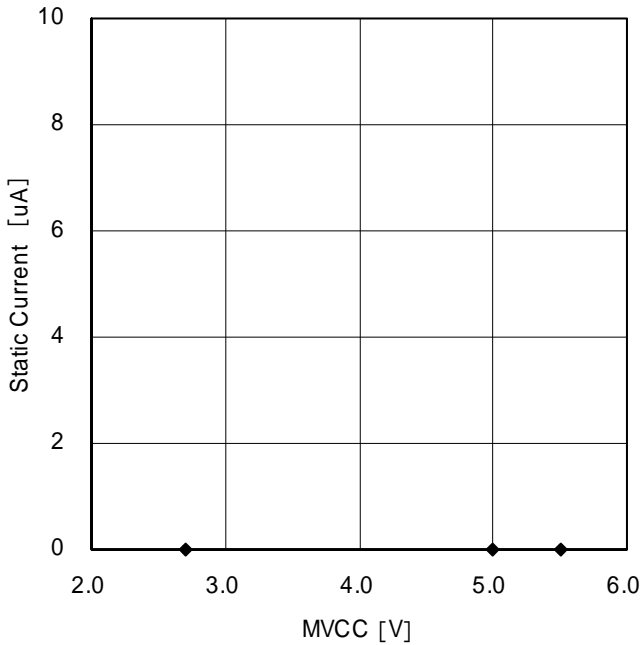

Figure 3. MVCC Static Current Voltage Dependency

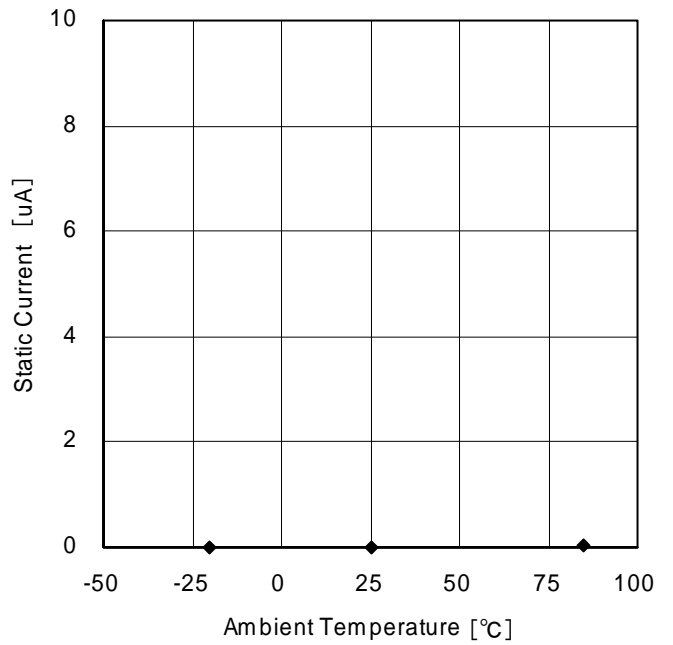

Figure 4. MVCC Static Current Temperature Dependency

● Typical Performance Curves

(Unless otherwise specified, $T_a=25^\circ\text{C}$, $DVDD=3.0\text{V}$, $MVCC=5.0\text{V}$, $DVSS=MGND=0.0\text{V}$)

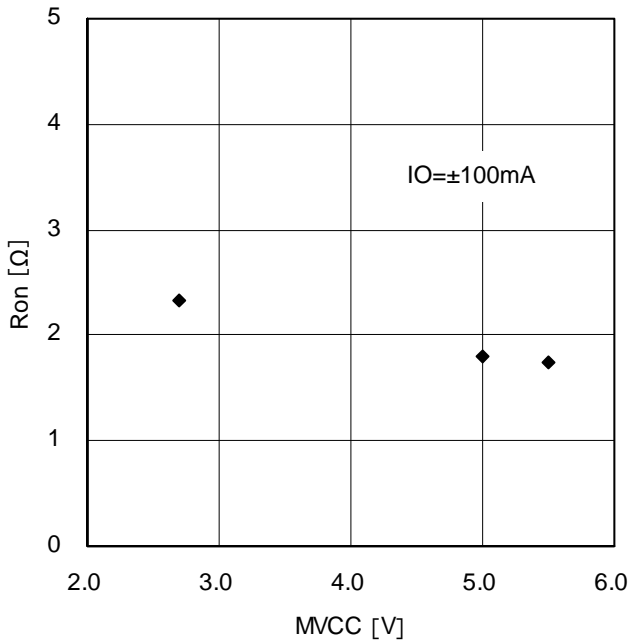

Figure 5. Output ON-Resistance
MVCC Dependency
(Voltage driver block)

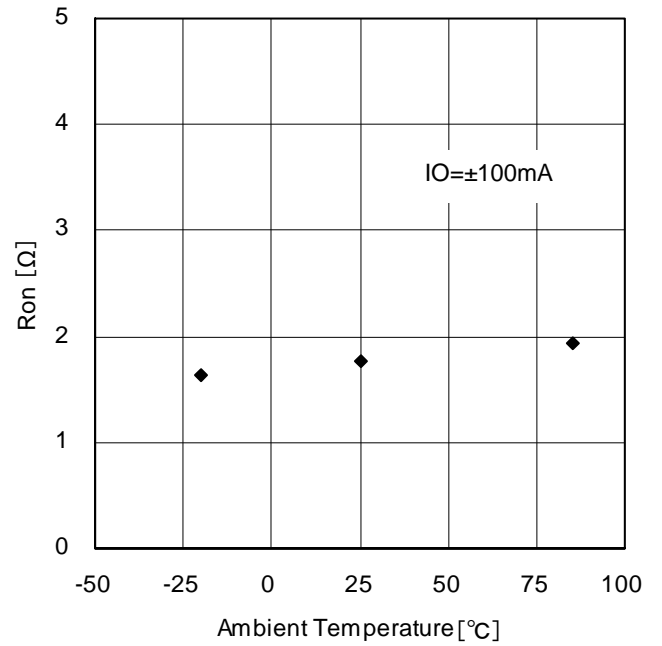

Figure 6. Output ON-Resistance
Temperature Dependency
(Voltage driver block)

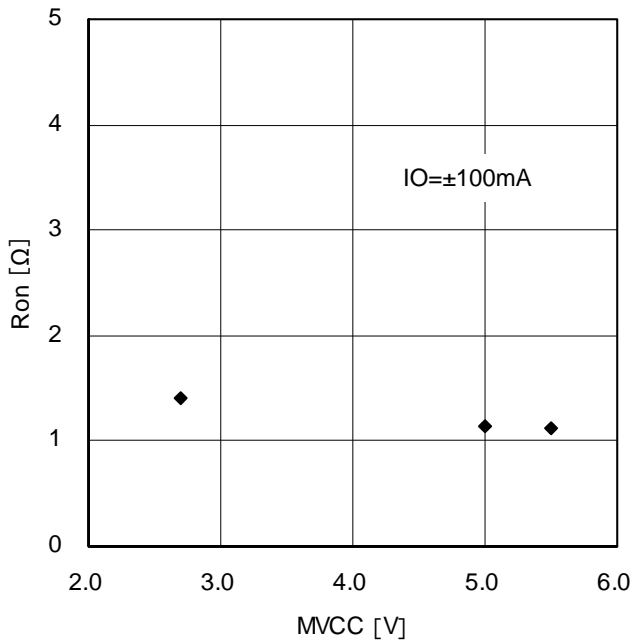

Figure 7. Output ON-Resistance
MVCC Dependency
(Current driver block)

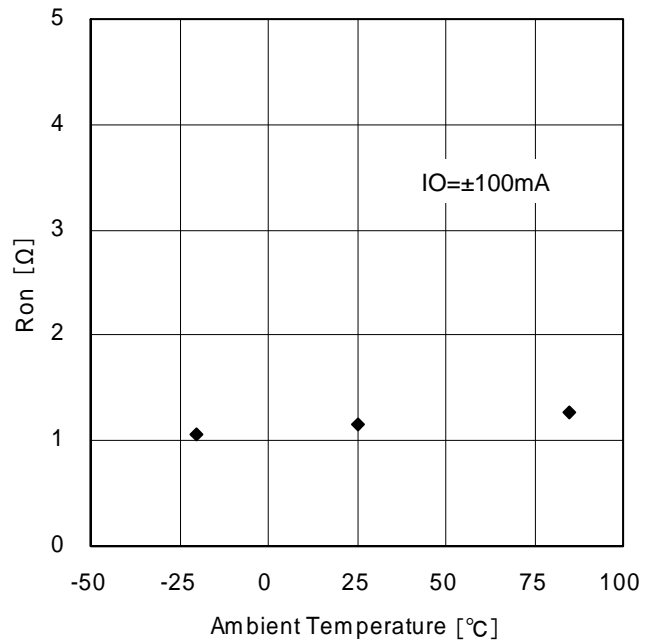

Figure 8. Output ON-Resistance
Temperature Dependency
(Current driver block)

● Typical Performance Curves

(Unless otherwise specified, $T_a=25^{\circ}\text{C}$, $\text{DVDD}=3.0\text{V}$, $\text{MVCC}=5.0\text{V}$, $\text{DVSS}=\text{MGND}=0.0\text{V}$)

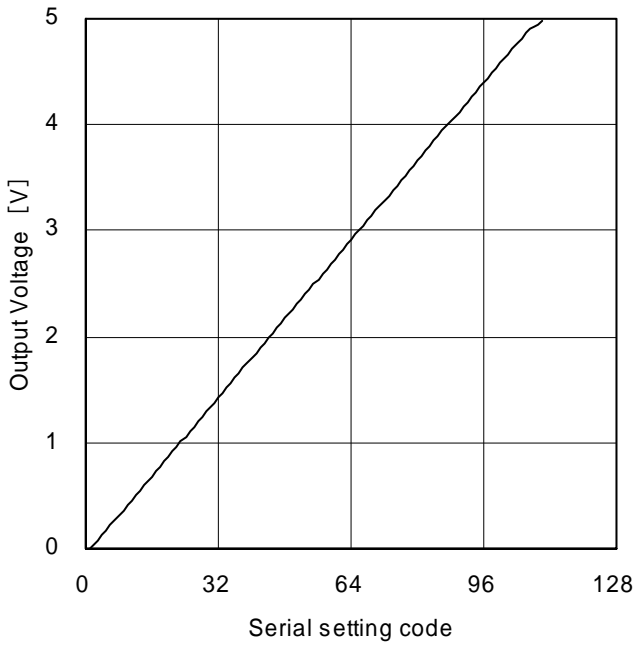

Figure 9. Average Voltage Accuracy between different output pins (Voltage driver block)

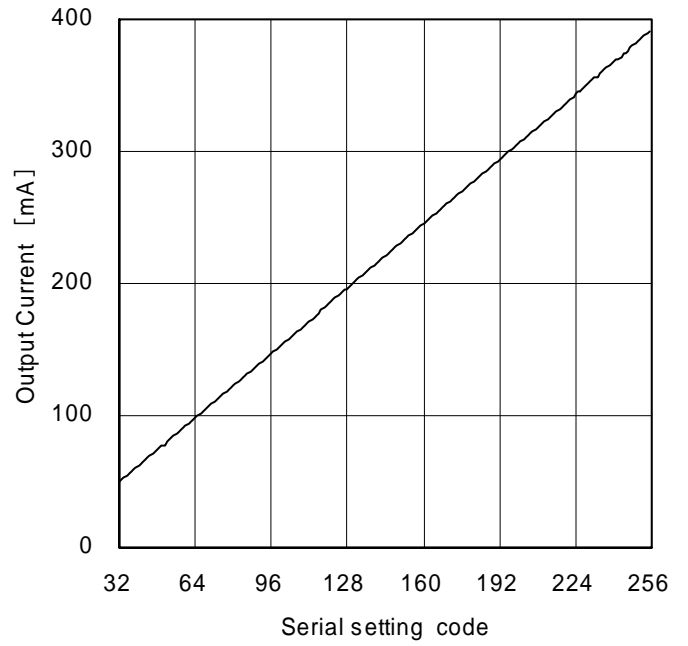

Figure 10. Output Current (Current driver block, $\text{RRNF} = 1.0\Omega$, $\text{RL} = 5.0\Omega$)

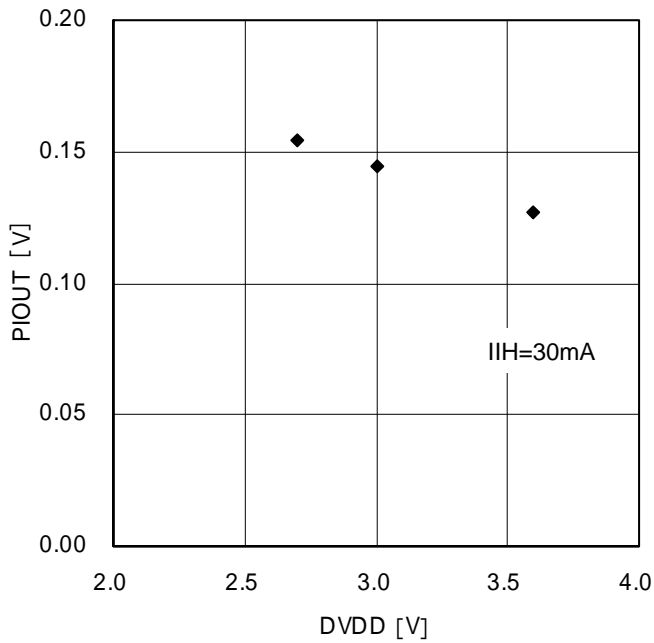

Figure 11. Output Voltage DVDD Dependency (PI driving circuit)

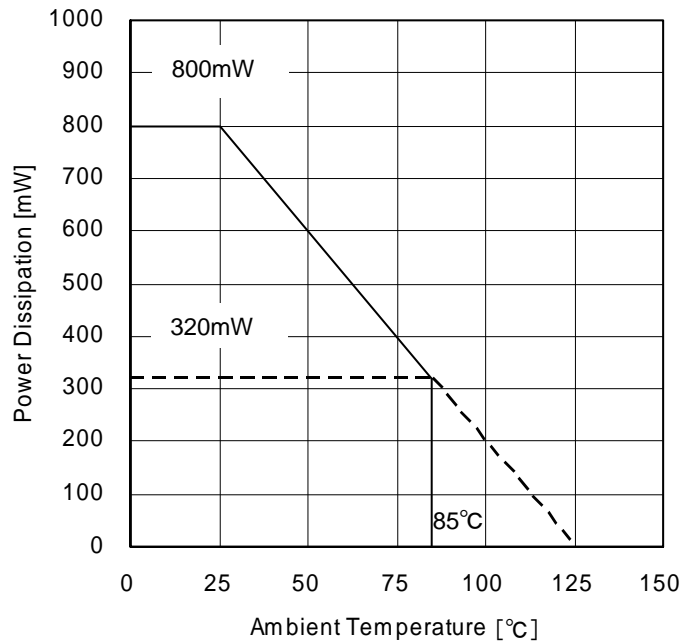
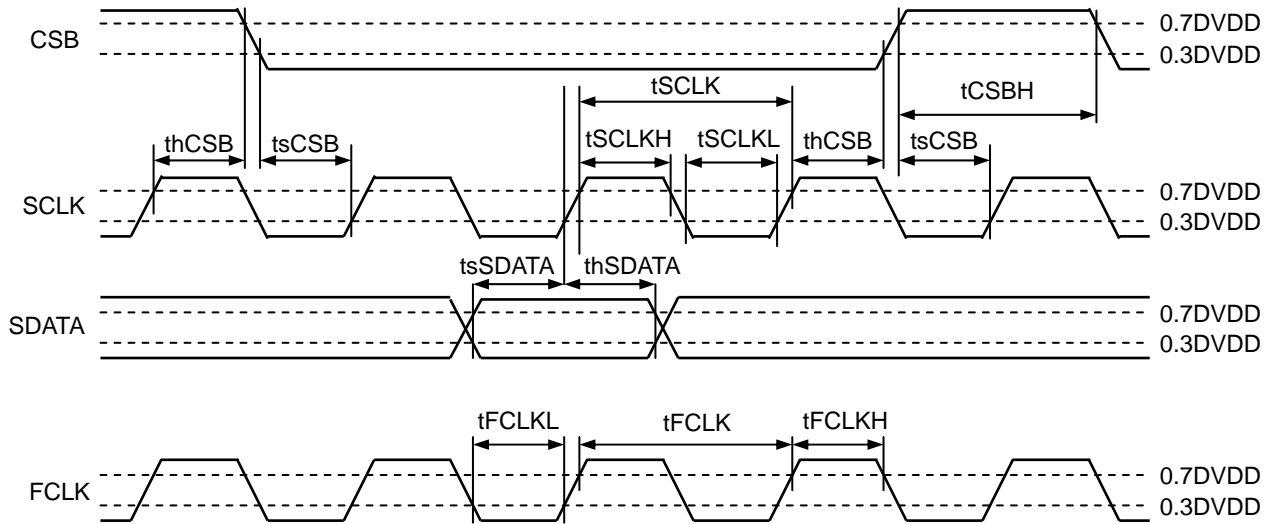

Figure 12. Power Dissipation Curve

●Timing Chart

(Unless otherwise specified, $T_a=25^{\circ}\text{C}$, $\text{DVDD} = 3.0\text{V}$)

Parameter	Symbol	Specification
SCLK input cycle	tSCLK	More than 100 nsec
SCLK L-level input time	tSCLKL	More than 50 nsec
SCLK H-level input time	tSCLKH	More than 50 nsec
SDATA setup time	tsSDATA	More than 50 nsec
SDATA hold time	thSDATA	More than 50 nsec
CSB H-level input time	tCSBH	More than 380 nsec
CSB setup time	tsCSB	More than 50 nsec
CSB hold time	thCSB	More than 50 nsec
FCLK input cycle	tFCLK	More than 36 nsec
FCLK L-level input time	tFCLKL	More than 18 nsec
FCLK H-level input time	tFCLKH	More than 18 nsec



(note1) FCLK is asynchronous with SCLK.
 (note2) Duty of FCLK, SCLK are free.

●Serial interface

Control commands are framed by a 16-bit serial input (MSB first) and are sent through CSB, SCLK, and SDATA pins. The 4 higher-order bits specify addresses, while the remaining 12 bits specify data. Data of every bit is sent through SDATA pin, which is retrieved during the rising edge of SCLK. Data becomes valid when CSB is Low and is registered during the rising edge of CSB. Furthermore, the interface will be synchronized with the falling edges of SCLK to output the SOUT data of the 12 bits.

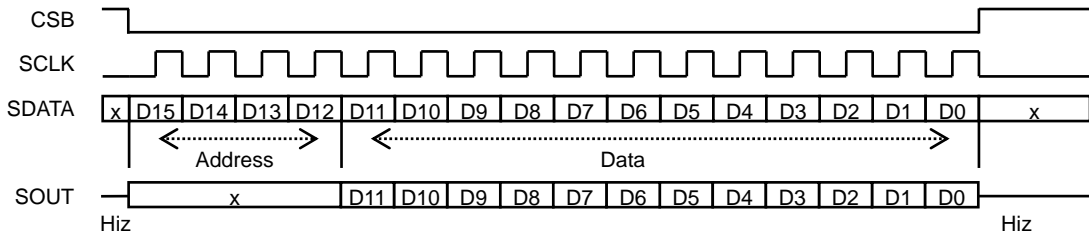

<Register map>

Address[3:0]				Data[11:0]												
15	14	13	12	11	10	9	8	7	6	5	4	3	2	1	0	
0	0	0	0	A_Mode[1:0]		A_SEL[2:0]		A_different_output_voltage[6:0]						0	0	
0	0	0	1	0	0	0	0	A_Cycle[5:0]						0	0	
				0	0	1	0	A_Cycle[13:6]								
				0	1	0	0	0	0	0	A_Start_POS[3:0]					
				0	1	1	0	A_BEXC	0	0	A_BSL	A_AEXC	0	0	A_AS_L	
0	0	1	0	1	1	1	0	0	0	A_POS[1:0]		0	0	A_PS	A_Stop	
0	0	1	1	A_EN	A_RT	A_Pulse[9:0]										
0	0	1	1	A_ACT	A_BUSY	L	L	L	L	L	L	L	L	L	L	
0	1	1	1	A_Position[9:6]				L	L	L	L	L	L	L	L	
1	0	1	1	0	0	0	0	0	0	0	0	0	0	0	A_CTL	
				0	0	1	0	0	0	SO3_SEL	45_SEL	0	0	0	EXT_CTL	
1	1	0	1	0	0	Chopping[1:0]		CacheM	0	0	CLK_EN	CLK_DIV[3:0]				
				0	0	0	0	0	0	0	0	0	0	PI_CTL2	PI_CTL1	
				0	0	1	0	0	0	0	0	0	3_State_CTL[1:0]		3_CHOP[1:0]	
				0	1	0	0	0	3_PWM_Duty[6:0]							
				0	1	1	0	0	0	0	0	0	4_State_CTL[1:0]		4_CHOP[1:0]	
				0	1	1	1	0	4_PWM_Duty[6:0]							
				1	0	0	0	5_DET_SEL	0	0	5_SPEN	5_State_CTL[1:0]		5_CHOP[1:0]		
				1	0	0	1	0	5_PWM_Duty[6:0]							
				1	0	1	0	5_TARSP[7:0]								
				1	0	1	1	0	5_PSP[2:0]			0	5_ISP[2:0]			
1	1	1	0	0	0	0	0	6_IOUT[7:0]								
				0	1	0	0	0	0	0	0	0	0	6_State_CTL[1:0]		
				1	0	1	0	0	0	0	0	0	HYS3	HYS2	HYS1	
				1	1	0	0	0	0	0	0	0	STB	0	STM_RS	CMD_RS
Addresses other than those above				Setting prohibited												

(Note1) The notation A is defined as Ach: 1ch and 2ch driver.
 (Note2) After reset (Power ON reset), the initial condition is saved in all registers.
 (Note3) The addresses 4'b0011, and 4'b0111 have data (ACT, BUSY, Position [9:6]), which are internal register values and output from SOUT pin.
 (Note4) For Mode, different output voltage, Cycle, EN, and RT registers, data that are written before the access to the Pulse register becomes valid and determines the rising edge of CSB after the access to the Pulse register.
 (The Mode, different output voltage, Cycle, EN, RT, and Pulse registers contain Cache registers. Any registers other than those do not contain Cache registers.)

●Application Example

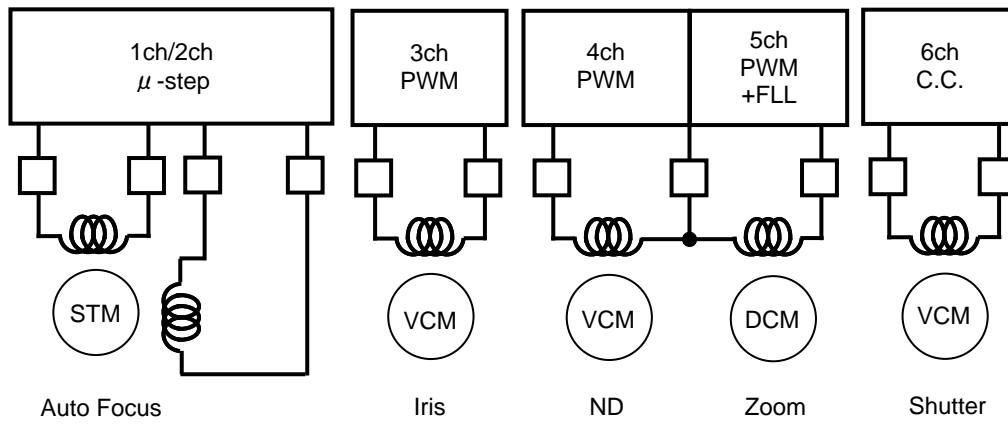

● I/O Equivalence Circuit

Pin	Equivalent Circuit Diagram	Pin	Equivalent Circuit Diagram
FCLK CSB SCLK SDATA		STATE/IN6	
SI1 SI2 SI3		SO1 SO2 SO3/SOUT	
PIOUT1		PIOUT2	
OUT1A OUT1B OUT2A OUT2B		OUT3A OUT3B OUT4A OUT5A OUT4B/5B	
OUT6A OUT6B			

●Operational Notes

- 1) Absolute maximum ratings
If applied voltage, operating temperature range, or other absolute maximum ratings are exceeded, the LSI may be damaged. Do not apply voltages or temperatures that exceed the absolute maximum ratings. If you expect that any voltage or temperature could be exceeding the absolute maximum ratings, take physical safety measures such as fuses to prevent any conditions exceeding the absolute maximum ratings from being applied to the LSI.
- 2) GND potential
The voltage of the ground pin must be the lowest voltage of all pins of the IC at all operating conditions. Ensure that no pins are at a voltage below the ground pin at any time, even during transient condition.
- 3) Thermal design
Use a thermal design that allows for a sufficient margin by taking into account the permissible power dissipation (PD) in actual operating conditions.
- 4) Short circuit between pins and malfunctions
Ensure that when mounting the IC on the PCB the direction and position are correct. Incorrect mounting may result in damaging the IC. Avoid nearby pins being shorted to each other especially to ground. Inter-pin shorts could be due to many reasons such as metal particles, water droplets (in very humid environment) and unintentional solder bridge deposited in between pins during assembly to name a few.
- 5) Operation in strong magnetic field
Operating the IC in the presence of a strong electromagnetic field may cause the IC to malfunction.
- 6) Power ON sequence
To turn ON the DVDD, be sure to reset at CMD_RS register.
- 7) Thermal shutdown
The IC incorporates a built-in thermal shutdown circuit, which is designed to turn off the IC when the internal temperature of the IC reaches a specified value. It is not designed to protect the IC from damage or guarantee its operation. Do not continue to operate the IC after this function is activated. Do not use the IC in conditions where this function will always be activated.
- 8) PI drive circuit
The output voltage of PIOU1 should not exceed the voltage of the power supply voltage DVDD.
The output voltage of PIOU2 should not exceed the voltage of the power supply voltage VDDAMP.

● Ordering Information

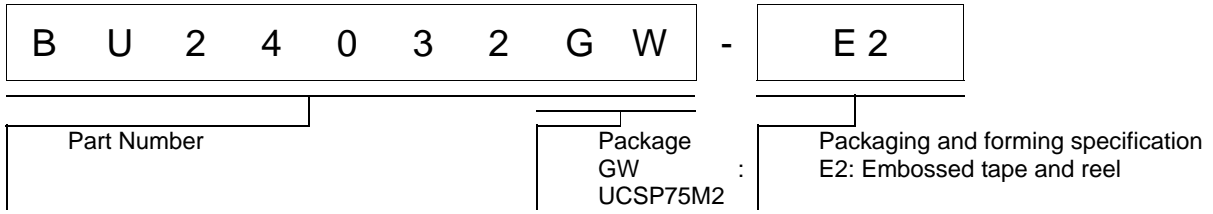

● Marking Diagram

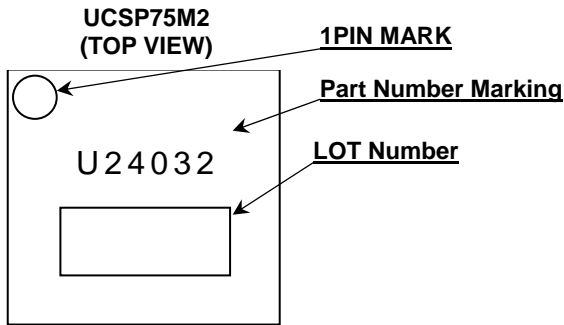

●Physical Dimension Tape and Reel Information

Package Name	UCSP75M2
--------------	----------

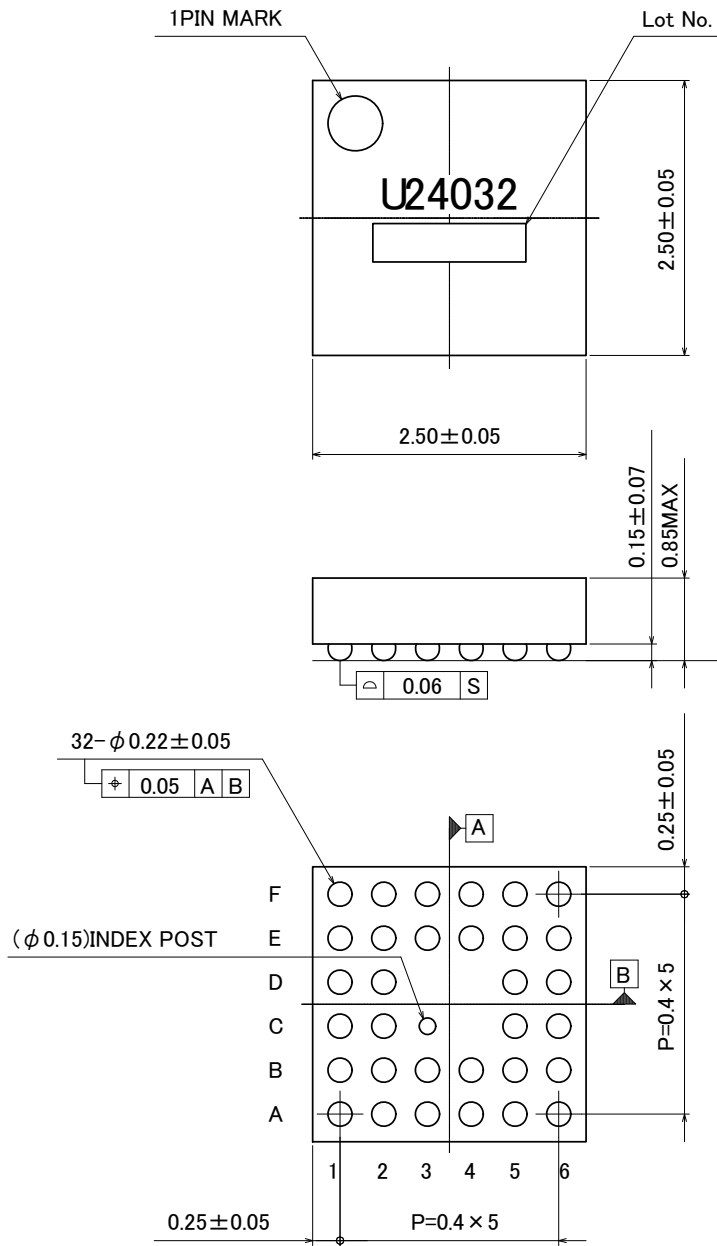

Tape	Embossed carriertape
Quantity	3,000pcs/Reel
Direction of feed	E2 (The direction is 1pin product is at the upper left when you hold reel on the hand and you pull out the tape on the right hand)

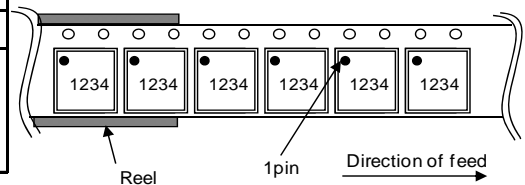

●Revision History

Date	Revision	Changes
26.Sep.2012	001	New Release
18.Apr.2013	002	Update some English words, sentences, descriptions, grammar and formatting.

Notice

Precaution on using ROHM Products

- Our Products are designed and manufactured for application in ordinary electronic equipments (such as AV equipment, OA equipment, telecommunication equipment, home electronic appliances, amusement equipment, etc.). If you intend to use our Products in devices requiring extremely high reliability (such as medical equipment ^(Note 1), transport equipment, traffic equipment, aircraft/spacecraft, nuclear power controllers, fuel controllers, car equipment including car accessories, safety devices, etc.) and whose malfunction or failure may cause loss of human life, bodily injury or serious damage to property ("Specific Applications"), please consult with the ROHM sales representative in advance. Unless otherwise agreed in writing by ROHM in advance, ROHM shall not be in any way responsible or liable for any damages, expenses or losses incurred by you or third parties arising from the use of any ROHM's Products for Specific Applications.

(Note1) Medical Equipment Classification of the Specific Applications

JAPAN	USA	EU	CHINA
CLASS III	CLASS III	CLASS II b	CLASS III
CLASS IV		CLASS III	

- ROHM designs and manufactures its Products subject to strict quality control system. However, semiconductor products can fail or malfunction at a certain rate. Please be sure to implement, at your own responsibilities, adequate safety measures including but not limited to fail-safe design against the physical injury, damage to any property, which a failure or malfunction of our Products may cause. The following are examples of safety measures:
 - Installation of protection circuits or other protective devices to improve system safety
 - Installation of redundant circuits to reduce the impact of single or multiple circuit failure
- Our Products are designed and manufactured for use under standard conditions and not under any special or extraordinary environments or conditions, as exemplified below. Accordingly, ROHM shall not be in any way responsible or liable for any damages, expenses or losses arising from the use of any ROHM's Products under any special or extraordinary environments or conditions. If you intend to use our Products under any special or extraordinary environments or conditions (as exemplified below), your independent verification and confirmation of product performance, reliability, etc. prior to use, must be necessary:
 - Use of our Products in any types of liquid, including water, oils, chemicals, and organic solvents
 - Use of our Products outdoors or in places where the Products are exposed to direct sunlight or dust
 - Use of our Products in places where the Products are exposed to sea wind or corrosive gases, including Cl₂, H₂S, NH₃, SO₂, and NO₂
 - Use of our Products in places where the Products are exposed to static electricity or electromagnetic waves
 - Use of our Products in proximity to heat-producing components, plastic cords, or other flammable items
 - Sealing or coating our Products with resin or other coating materials
 - Use of our Products without cleaning residue of flux (even if you use no-clean type fluxes, cleaning residue of flux is recommended); or Washing our Products by using water or water-soluble cleaning agents for cleaning residue after soldering
 - Use of the Products in places subject to dew condensation
- The Products are not subject to radiation-proof design.
- Please verify and confirm characteristics of the final or mounted products in using the Products.
- In particular, if a transient load (a large amount of load applied in a short period of time, such as pulse. is applied, confirmation of performance characteristics after on-board mounting is strongly recommended. Avoid applying power exceeding normal rated power; exceeding the power rating under steady-state loading condition may negatively affect product performance and reliability.
- De-rate Power Dissipation (Pd) depending on Ambient temperature (Ta). When used in sealed area, confirm the actual ambient temperature.
- Confirm that operation temperature is within the specified range described in the product specification.
- ROHM shall not be in any way responsible or liable for failure induced under deviant condition from what is defined in this document.

Precaution for Mounting / Circuit board design

- When a highly active halogenous (chlorine, bromine, etc.) flux is used, the residue of flux may negatively affect product performance and reliability.
- In principle, the reflow soldering method must be used; if flow soldering method is preferred, please consult with the ROHM representative in advance.

For details, please refer to ROHM Mounting specification

Precautions Regarding Application Examples and External Circuits

1. If change is made to the constant of an external circuit, please allow a sufficient margin considering variations of the characteristics of the Products and external components, including transient characteristics, as well as static characteristics.
2. You agree that application notes, reference designs, and associated data and information contained in this document are presented only as guidance for Products use. Therefore, in case you use such information, you are solely responsible for it and you must exercise your own independent verification and judgment in the use of such information contained in this document. ROHM shall not be in any way responsible or liable for any damages, expenses or losses incurred by you or third parties arising from the use of such information.

Precaution for Electrostatic

This Product is electrostatic sensitive product, which may be damaged due to electrostatic discharge. Please take proper caution in your manufacturing process and storage so that voltage exceeding the Products maximum rating will not be applied to Products. Please take special care under dry condition (e.g. Grounding of human body / equipment / solder iron, isolation from charged objects, setting of ionizer, friction prevention and temperature / humidity control).

Precaution for Storage / Transportation

1. Product performance and soldered connections may deteriorate if the Products are stored in the places where:
 - [a] the Products are exposed to sea winds or corrosive gases, including Cl₂, H₂S, NH₃, SO₂, and NO₂
 - [b] the temperature or humidity exceeds those recommended by ROHM
 - [c] the Products are exposed to direct sunshine or condensation
 - [d] the Products are exposed to high Electrostatic
2. Even under ROHM recommended storage condition, solderability of products out of recommended storage time period may be degraded. It is strongly recommended to confirm solderability before using Products of which storage time is exceeding the recommended storage time period.
3. Store / transport cartons in the correct direction, which is indicated on a carton with a symbol. Otherwise bent leads may occur due to excessive stress applied when dropping of a carton.
4. Use Products within the specified time after opening a humidity barrier bag. Baking is required before using Products of which storage time is exceeding the recommended storage time period.

Precaution for Product Label

QR code printed on ROHM Products label is for ROHM's internal use only.

Precaution for Disposition

When disposing Products please dispose them properly using an authorized industry waste company.

Precaution for Foreign Exchange and Foreign Trade act

Since our Products might fall under controlled goods prescribed by the applicable foreign exchange and foreign trade act, please consult with ROHM representative in case of export.

Precaution Regarding Intellectual Property Rights

1. All information and data including but not limited to application example contained in this document is for reference only. ROHM does not warrant that foregoing information or data will not infringe any intellectual property rights or any other rights of any third party regarding such information or data. ROHM shall not be in any way responsible or liable for infringement of any intellectual property rights or other damages arising from use of such information or data.:
2. No license, expressly or implied, is granted hereby under any intellectual property rights or other rights of ROHM or any third parties with respect to the information contained in this document.

Other Precaution

1. This document may not be reprinted or reproduced, in whole or in part, without prior written consent of ROHM.
2. The Products may not be disassembled, converted, modified, reproduced or otherwise changed without prior written consent of ROHM.
3. In no event shall you use in any way whatsoever the Products and the related technical information contained in the Products or this document for any military purposes, including but not limited to, the development of mass-destruction weapons.
4. The proper names of companies or products described in this document are trademarks or registered trademarks of ROHM, its affiliated companies or third parties.

General Precaution

1. Before you use our Products, you are requested to carefully read this document and fully understand its contents. ROHM shall not be in any way responsible or liable for failure, malfunction or accident arising from the use of any ROHM's Products against warning, caution or note contained in this document.
2. All information contained in this document is current as of the issuing date and subject to change without any prior notice. Before purchasing or using ROHM's Products, please confirm the latest information with a ROHM sales representative.
3. The information contained in this document is provided on an "as is" basis and ROHM does not warrant that all information contained in this document is accurate and/or error-free. ROHM shall not be in any way responsible or liable for any damages, expenses or losses incurred by you or third parties resulting from inaccuracy or errors of or concerning such information.



Компания «ЭлектроПласт» предлагает заключение долгосрочных отношений при поставках импортных электронных компонентов на взаимовыгодных условиях!

Наши преимущества:

- Оперативные поставки широкого спектра электронных компонентов отечественного и импортного производства напрямую от производителей и с крупнейших мировых складов;
- Поставка более 17-ти миллионов наименований электронных компонентов;
- Поставка сложных, дефицитных, либо снятых с производства позиций;
- Оперативные сроки поставки под заказ (от 5 рабочих дней);
- Экспресс доставка в любую точку России;
- Техническая поддержка проекта, помощь в подборе аналогов, поставка прототипов;
- Система менеджмента качества сертифицирована по Международному стандарту ISO 9001;
- Лицензия ФСБ на осуществление работ с использованием сведений, составляющих государственную тайну;
- Поставка специализированных компонентов (Xilinx, Altera, Analog Devices, Intersil, Interpoint, Microsemi, Aeroflex, Peregrine, Syfer, Eurofarad, Texas Instrument, Miteq, Cobham, E2V, MA-COM, Hittite, Mini-Circuits, General Dynamics и др.);

Помимо этого, одним из направлений компании «ЭлектроПласт» является направление «Источники питания». Мы предлагаем Вам помощь Конструкторского отдела:

- Подбор оптимального решения, техническое обоснование при выборе компонента;
- Подбор аналогов;
- Консультации по применению компонента;
- Поставка образцов и прототипов;
- Техническая поддержка проекта;
- Защита от снятия компонента с производства.



Как с нами связаться

Телефон: 8 (812) 309 58 32 (многоканальный)

Факс: 8 (812) 320-02-42

Электронная почта: org@eplast1.ru

Адрес: 198099, г. Санкт-Петербург, ул. Калинина, дом 2, корпус 4, литера А.