

NHD-C12864B2Z-RN-FBW

COG (Chip-On-Glass) Liquid Crystal Display Module

NHD-	Newhaven Display
C12864-	128 x 64 Pixels
B2Z-	Model
R-	Reflective
N-	No Backlight
F-	FSTN (+)
B-	6:00 view
W-	Wide Temp (-20°C ~ +70°C)
	RoHS Compliant

Newhaven Display International, Inc.

2511 Technology Drive, Suite 101

Elgin IL, 60124

Ph: 847-844-8795

Fax: 847-844-8796

www.newhavendisplay.com

nhtech@newhavendisplay.com

nhsales@newhavendisplay.com

Document Revision History

Revision	Date	Description	Changed by
0	5/12/2008	Initial Release	-
1	3/18/2009	User guide reformat	-
2	7/14/2009	User guide reformat	BE
3	5/10/2011	Code Update	JT
4	11/7/2011	Example program updated	AK

Functions and Features

- 128 x 64 Pixels
- Built-in ST7565R controller
- 8080 MPU interfaces
- RoHS Compliant

Mechanical Drawing

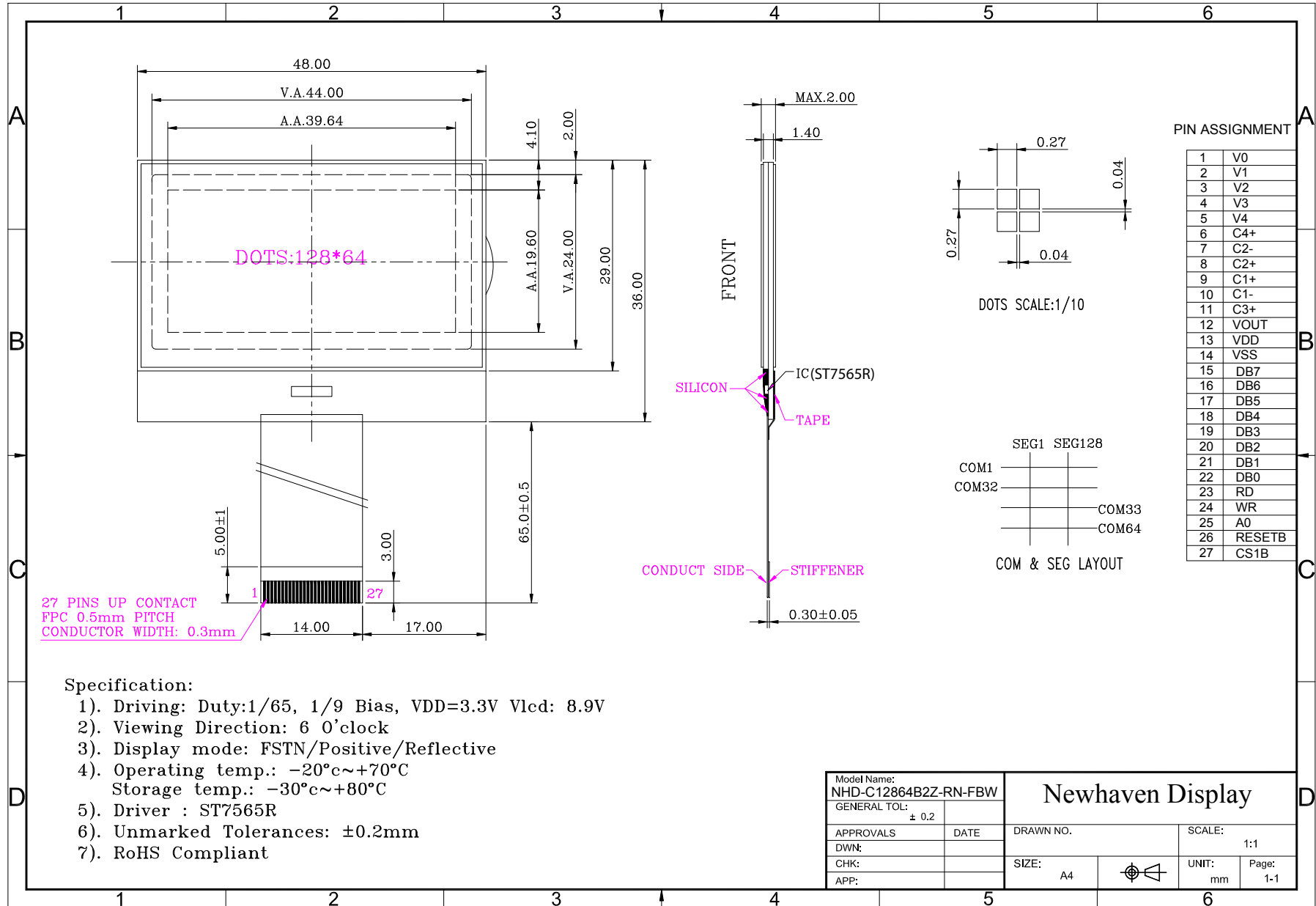

Specification:

- 1). Driving: Duty:1/65, 1/9 Bias, VDD=3.3V Vled: 8.9V
- 2). Viewing Direction: 6 O'clock
- 3). Display mode: FSTN/Positive/Reflective
- 4). Operating temp.: -20°C~+70°C
Storage temp.: -30°C~+80°C
- 5). Driver : ST7565R
- 6). Unmarked Tolerances: ±0.2mm
- 7). RoHS Compliant

Model Name: NHD-C12864B2Z-RN-FBW		Newhaven Display	
GENERAL TOL: ± 0.2			
APPROVALS	DATE	DRAWN NO.	SCALE: 1:1
DWN:		SIZE: A4	UNIT: mm
CHK:			Page: 1-1
APP:			

Pin Description and Wiring Diagram

Pin No.	Symbol	External Connection	Function Description
1	V0	Power Supply	CAP to VSS (0.1~1Uf)
2	V1	Power supply	CAP to VSS (0.1~1Uf)
3	V2	Power Supply	CAP to VSS (0.1~1Uf)
4	V3	Power Supply	CAP to VSS (0.1~1Uf)
5	V4	Power Supply	CAP to VSS (0.1~1Uf)
6	C4+	Power Supply	No Connect
7	C2-	Power Supply	CAP to PIN8 (1~2.2uF)
8	C2+	Power Supply	CAP to PIN7 (1~2.2uF)
9	C1+	Power Supply	CAP to PIN10(1~2.2uF)
10	C1-	Power Supply	CAP to PIN9 (1~2.2uF)
11	C3+	Power Supply	CAP to PIN10 (1~2.2uF)
12	V _{OUT}	Power Supply	CAP to VSS (1~2.2uF)
13	V _{DD}	Power Supply	Power Supply for logic
14	V _{SS}	Power Supply	Ground
15~22	DB7~DB0	MPU	This is an 8-bit-directional data bus.
23	/RD	MPU	Active low Read signal
24	/WR	MPU	Active low Write signal
25	A0	MPU	Register Select. 0: instruction; 1: data register
26	RESTB	MPU	Active low Reset signal. (May tie to VDD)
27	CS1B	MPU	Active low Chip Select. (May tie to VSS)

Recommended LCD connector: 27 pins, 0.5mm Pitch FFC

Backlight connector: --- **Mates with:** ---

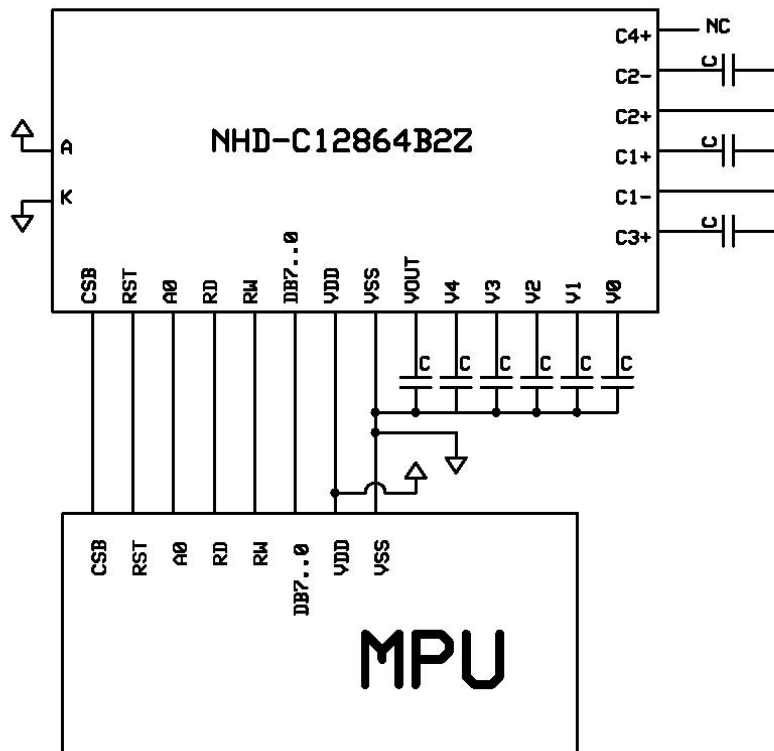

Electrical Characteristics

Item	Symbol	Condition	Min.	Typ.	Max.	Unit
Operating Temperature Range	Top	Absolute Max	-20	-	+70	°C
Storage Temperature Range	Tst	Absolute Max	-30	-	+80	°C
Supply Voltage	VDD		-	3.3	-	V
Supply Current	IDD	Ta=25III, VDD=3.3V	-	0.5	-	mA
Supply for LCD (contrast)	VDD-V0	Ta =25III	-	8.9	-	V
"H" Level input	Vih		0.7VDD	-	VDD	V
"L" Level input	Vil		0	-	0.8	V
"H" Level output	Voh		0.7VDD	-	VDD	V
"L" Level output	Vol		-	-	0.8	V

Optical Characteristics

Item	Symbol	Condition	Min.	Typ.	Max.	Unit
Viewing Angle - Vertical	K2- K 1	CR = 2.0	70	-	-	°
Viewing Angle - Horizontal	Φ	CR = 2.0	-	² 30	-	°
Contrast Ratio	CR	Φ=0, θ=25	3	5	-	-
Response Time (rise)	Tr	Φ=0, θ=25	-	150	250	ms
Response Time (fall)	Tf	Φ=0, θ=25	-	200	300	ms

Controller Information

Built-in ST7565R. Download specification at http://www.newhavendisplay.com/app_notes/ST7565R.pdf

Timing Characteristics

System bus read/write characteristics 1 (for the 8080 series MPU)

(Ta=25°C, VDD=3.0V)

Item	Signal	Symbol	condition	Min.	Max.	Unit
Address hold time	A0	t _{AH8}		0	-	ns
Address setup time		t _{AW8}		0	-	
Address cycle time		t _{CYC8}		240	-	
Enable L pulse width(write)	WR	t _{CCLW}		80	-	
Enable H pulse width(write)		t _{CCHW}		80	-	
Enable L pulse width(read)	RD	t _{CCLR}		140	-	
Enable H pulse width(read)		t _{CCHR}		80	-	
Write data setup time	DB0~DB7	t _{DS8}		40	-	
Write address hold time		t _{DH8}		0	-	
Read access time		t _{ACC8}	CL=100Pf	-	70	
Read output disable time		t _{OH8}	CL=100Pf	5	50	

Item	Signal	Symbol	Min.	Typ.	Max.	Unit
Reset time		t _R	-	-	1.0	us
Reset 'L' pulse width	/RES	t _{RW}	1.0	-	-	

System Bus Read/Write Characteristics 1 (For the 8080 Series MPU)

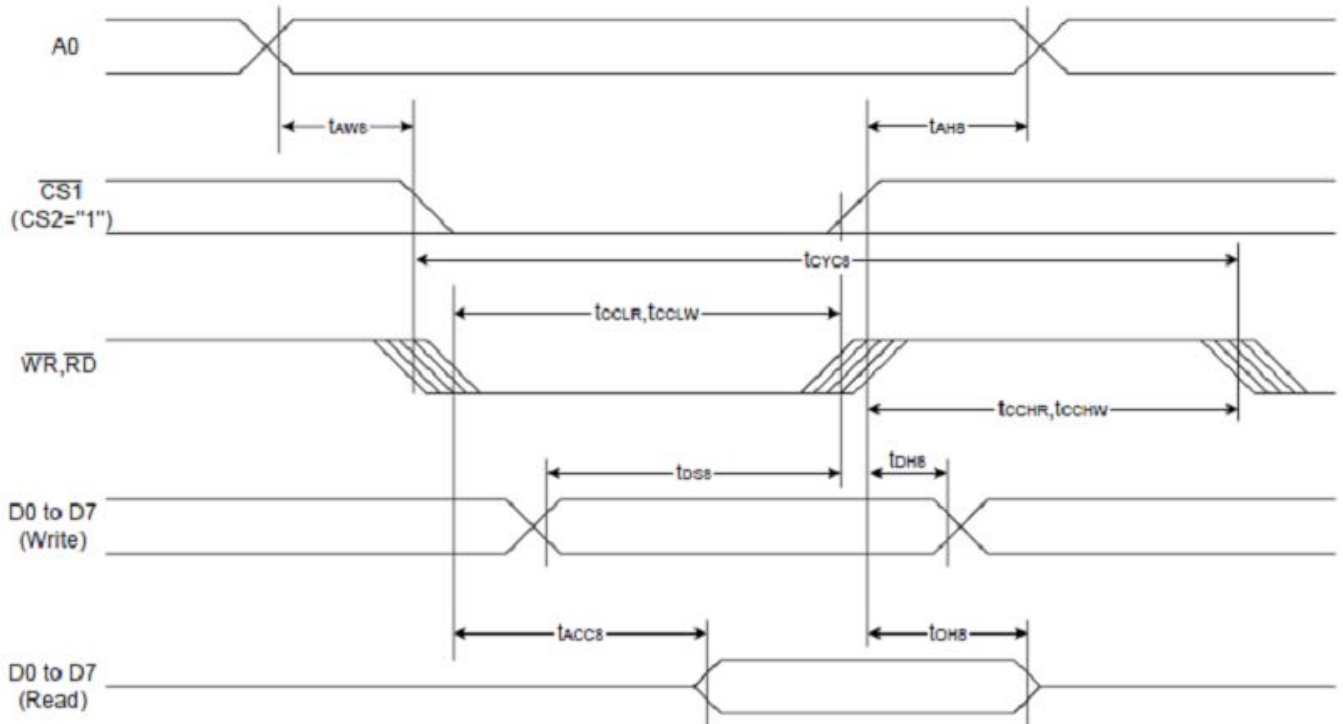

Table of Commands

Table 16: Table of ST7565R Commands

(Note) *: ignored data

Command	Command Code										Function		
	A0	/RD	/WR	D7	D6	D5	D4	D3	D2	D1		D0	
(1) Display ON/OFF	0	1	0	1	0	1	0	1	1	1	0	1	LCD display ON/OFF 0: OFF, 1: ON
(2) Display start line set	0	1	0	0	1	Display start address					0	Sets the display RAM display start line address	
(3) Page address set	0	1	0	1	0	1	Page address				0	Sets the display RAM page address	
(4) Column address set upper bit	0	1	0	0	0	0	1	Most significant column address				0	Sets the most significant 4 bits of the display RAM column address.
Column address set lower bit				0	0	0	0	Least significant column address				0	Sets the least significant 4 bits of the display RAM column address.
(5) Status read	0	0	1	Status				0	0	0	0	0	Reads the status data
(6) Display data write	1	1	0	Write data							0	Writes to the display RAM	
(7) Display data read	1	0	1	Read data							0	Reads from the display RAM	
(8) ADC select	0	1	0	1	0	1	0	0	0	0	0	0	Sets the display RAM address SEG output correspondence 0: normal, 1: reverse
(9) Display normal/reverse	0	1	0	1	0	1	0	0	1	1	0	1	Sets the LCD display normal/ reverse 0: normal, 1: reverse
(10) Display all points ON/OFF	0	1	0	1	0	1	0	0	1	0	0	1	Display all points 0: normal display 1: all points ON
(11) LCD bias set	0	1	0	1	0	1	0	0	0	1	0	1	Sets the LCD drive voltage bias ratio 0: 1/9 bias, 1: 1/7 bias (ST7565R)
(12) Read-modify-write	0	1	0	1	1	1	0	0	0	0	0	0	Column address increment At write: +1 At read: 0
(13) End	0	1	0	1	1	1	0	1	1	1	0	0	Clear read/modify/write
(14) Reset	0	1	0	1	1	1	0	0	0	1	0	0	Internal reset
(15) Common output mode select	0	1	0	1	1	0	0	0	*	*	*	1	Select COM output scan direction 0: normal direction 1: reverse direction
(16) Power control set	0	1	0	0	0	1	0	1	Operating mode		0	0	Select internal power supply operating mode
(17) V ₀ voltage regulator internal resistor ratio set	0	1	0	0	0	1	0	0	Resistor ratio		0	0	Select internal resistor ratio(Rb/Ra) mode
(18) Electronic volume mode set	0	1	0	1	0	0	0	0	0	0	0	1	Set the V ₀ output voltage electronic volume register
Electronic volume register set				0	0	Electronic volume value					0	0	
(19) Sleep mode set	0	1	0	1	0	1	0	1	1	0	0	1	0: Sleep mode, 1: Normal mode
(20) Booster ratio set	0	1	0	1	1	1	1	1	0	0	0	0	select booster ratio 00: 2x,3x,4x 01: 5x 11: 6x
(21) NOP	0	1	0	1	1	1	0	0	0	1	1	1	Command for non-operation
(22) Test	0	1	0	1	1	1	1	*	*	*	*	*	Command for IC test. Do not use this command

Example Initialization Program

```
'-----  
Sub Init  
Reset P3.7          'set Read/write to '0' for write  
Reset P3.0          'RS  
Set P3.1            'reset  
Reset P3.4 'E  
'Set P3.3  
'Reset P3.3  
Waitms 2  
'Set P3.3  
Waitms 20  
A = &HA2            '1/9 BIAS  
Call Writecom  
A = &HA0            'ADC SELECT , NORMAL  
Call Writecom  
A = &HC8            'COM OUTPUT REVERSE  
Call Writecom  
A = &HA4            'DISPLAY ALL POINTS NORMAL  
Call Writecom  
A = &H40            'DISPLAY START LINE SET  
Call Writecom  
A = &H25            'INTERNAL RESISTOR RATIO  
Call Writecom  
A = &H81            'ELECTRONIC VOLUME MODE SET  
Call Writecom  
A = &H10            'ELECTRONIC VOLUME  
Call Writecom  
A = &H2F            'POWER CONTROLLER SET  
Call Writecom  
A = &HAF            'DISPLAY ON  
Call Writecom  
End Sub
```

```
'-----  
Sub Writecom  
Reset P3.0          'A0 low  
Reset P3.7          'R/W low  
Set P3.6            'CS2  
Set P3.4            'E  
P1 = A  
Reset P3.4  
Reset P3.6  
Reset P3.7  
End Sub
```

```
Sub Writedata  
Set P3.0            'A0 high  
Reset P3.7          'R/W low  
Set P3.6            'CS2  
Set P3.4            'E  
P1 = A  
Reset P3.4  
Reset P3.6  
Reset P3.7  
End Sub  
'-----
```

Quality Information

Test Item	Content of Test	Test Condition	Note
High Temperature storage	Endurance test applying the high storage temperature for a long time.	+80°C , 48hrs	2
Low Temperature storage	Endurance test applying the low storage temperature for a long time.	-30°C , 48hrs	1,2
High Temperature Operation	Endurance test applying the electric stress (voltage & current) and the high thermal stress for a long time.	+70°C 48hrs	2
Low Temperature Operation	Endurance test applying the electric stress (voltage & current) and the low thermal stress for a long time.	-20°C , 48hrs	1,2
High Temperature / Humidity Operation	Endurance test applying the electric stress (voltage & current) and the high thermal with high humidity stress for a long time.	+40°C , 90% RH , 48hrs	1,2
Thermal Shock resistance	Endurance test applying the electric stress (voltage & current) during a cycle of low and high thermal stress.	-0°C,30min -> 25°C,5min -> 50°C,30min = 1 cycle 10 cycles	
Vibration test	Endurance test applying vibration to simulate transportation and use.	10-55Hz , 15mm amplitude. 60 sec in each of 3 directions X,Y,Z For 15 minutes	3
Static electricity test	Endurance test applying electric static discharge.	VS=800V, RS=1.5kΩ, CS=100pF One time	

Note 1: No condensation to be observed.

Note 2: Conducted after 4 hours of storage at 25°C, 0%RH.

Note 3: Test performed on product itself, not inside a container.

Precautions for using LCDs/LCMs

See Precautions at www.newhavendisplay.com/specs/precautions.pdf

Warranty Information and Terms & Conditions

http://www.newhavendisplay.com/index.php?main_page=terms



Компания «ЭлектроПласт» предлагает заключение долгосрочных отношений при поставках импортных электронных компонентов на взаимовыгодных условиях!

Наши преимущества:

- Оперативные поставки широкого спектра электронных компонентов отечественного и импортного производства напрямую от производителей и с крупнейших мировых складов;
- Поставка более 17-ти миллионов наименований электронных компонентов;
- Поставка сложных, дефицитных, либо снятых с производства позиций;
- Оперативные сроки поставки под заказ (от 5 рабочих дней);
- Экспресс доставка в любую точку России;
- Техническая поддержка проекта, помощь в подборе аналогов, поставка прототипов;
- Система менеджмента качества сертифицирована по Международному стандарту ISO 9001;
- Лицензия ФСБ на осуществление работ с использованием сведений, составляющих государственную тайну;
- Поставка специализированных компонентов (Xilinx, Altera, Analog Devices, Intersil, Interpoint, Microsemi, Aeroflex, Peregrine, Syfer, Eurofarad, Texas Instrument, Miteq, Cobham, E2V, MA-COM, Hittite, Mini-Circuits, General Dynamics и др.);

Помимо этого, одним из направлений компании «ЭлектроПласт» является направление «Источники питания». Мы предлагаем Вам помощь Конструкторского отдела:

- Подбор оптимального решения, техническое обоснование при выборе компонента;
- Подбор аналогов;
- Консультации по применению компонента;
- Поставка образцов и прототипов;
- Техническая поддержка проекта;
- Защита от снятия компонента с производства.



Как с нами связаться

Телефон: 8 (812) 309 58 32 (многоканальный)

Факс: 8 (812) 320-02-42

Электронная почта: org@eplast1.ru

Адрес: 198099, г. Санкт-Петербург, ул. Калинина, дом 2, корпус 4, литера А.