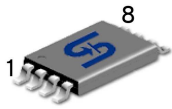

TSM6968SD

20V Dual N-Channel MOSFET w/ESD Protected

TSSOP-8

Pin Definition:

- | | |
|-------------|-------------|
| 1. Drain 1 | 8. Drain 2 |
| 2. Source 1 | 7. Source 2 |
| 3. Source 1 | 6. Source 2 |
| 4. Gate 1 | 5. Gate 2 |

PRODUCT SUMMARY

V_{DS} (V)	$R_{DS(on)}$ (m Ω)	I_D (A)
20	22 @ $V_{GS} = 4.5V$	6.5
	29 @ $V_{GS} = 2.5V$	5.5

Features

- Advance Trench Process Technology
- High Density Cell Design for Ultra Low On-resistance
- ESD Protect 2KV

Application

- Specially Designed for Li-on Battery Packs
- Battery Switch Application

Ordering Information

Part No.	Package	Packing
TSM6968SDCA RVG	TSSOP-8	3Kpcs / 13" Reel

Note: "G" denotes for Halogen Free

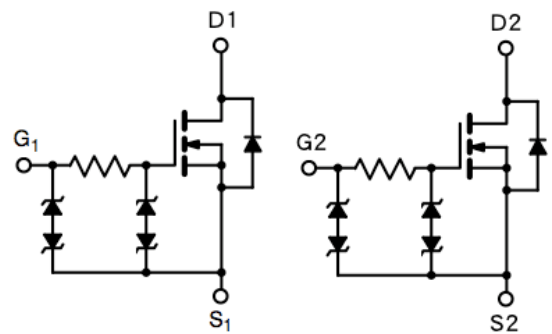
Block Diagram

Dual N-Channel MOSFET

Absolute Maximum Rating ($T_a = 25^\circ C$ unless otherwise noted)

Parameter	Symbol	Limit	Unit
Drain-Source Voltage	V_{DS}	20	V
Gate-Source Voltage	V_{GS}	± 12	V
Continuous Drain Current, $V_{GS} @ 4.5V$.	I_D	6.5	A
Pulsed Drain Current, $V_{GS} @ 4.5V$	I_{DM}	30	A
Continuous Source Current (Diode Conduction) ^{a,b}	I_S	1.4	A
Maximum Power Dissipation	P_D	$T_a = 25^\circ C$	1.04
		$T_a = 75^\circ C$	0.625
Operating Junction Temperature	T_J	+150	$^\circ C$
Operating Junction and Storage Temperature Range	T_J, T_{STG}	-55 to +150	$^\circ C$

Thermal Performance

Parameter	Symbol	Limit	Unit
Junction to Foot (Drain) Thermal Resistance	$R_{\theta_{JF}}$	83	$^\circ C/W$
Junction to Ambient Thermal Resistance (PCB mounted)	$R_{\theta_{JA}}$	120	$^\circ C/W$

Notes:

- Pulse width limited by the Maximum junction temperature
- Surface Mounted on FR4 Board, $t \leq 5$ sec.

Electrical Specifications (Ta = 25°C unless otherwise noted)

Parameter	Conditions	Symbol	Min	Typ	Max	Unit
Static						
Drain-Source Breakdown Voltage	V _{GS} = 0V, I _D = 250uA	BV _{DSS}	20	--	--	V
Gate Threshold Voltage	V _{DS} = V _{GS} , I _D = 250uA	V _{GS(TH)}	0.6	0.8	1.0	V
Gate Body Leakage	V _{GS} = ±12V, V _{DS} = 0V	I _{GSS}	--	--	±10	uA
Zero Gate Voltage Drain Current	V _{DS} = 16V, V _{GS} = 0V	I _{DSS}	--	--	1.0	uA
On-State Drain Current	V _{DS} = 5V, V _{GS} = 4.5V	I _{D(ON)}	30	--	--	A
Drain-Source On-State Resistance	V _{GS} = 4.5V, I _D = 6.5A	R _{DS(ON)}	--	15	22	mΩ
	V _{GS} = 2.5V, I _D = 5.5A		--	20	29	
Forward Transconductance	V _{DS} = 10V, I _D = 6.5A	g _{fs}	--	30	--	S
Diode Forward Voltage	I _S = 1.7A, V _{GS} = 0V	V _{SD}	--	0.6	1.2	V
Dynamic^b						
Total Gate Charge	V _{DS} = 10V, I _D = 6.5A, V _{GS} = 4.5V	Q _g	--	15	20	nC
Gate-Source Charge		Q _{gs}	--	3.4	--	
Gate-Drain Charge		Q _{gd}	--	1.2	--	
Input Capacitance	V _{DS} = 10V, V _{GS} = 0V, f = 1.0MHz	C _{iss}	--	950	--	pF
Output Capacitance		C _{oss}	--	450	--	
Reverse Transfer Capacitance		C _{rss}	--	135	--	
Switching^c						
Turn-On Delay Time	V _{DD} = 10V, R _L = 10Ω, I _D = 1A, V _{GEN} = 4.5V, R _G = 6Ω	t _{d(on)}	--	140	200	nS
Turn-On Rise Time		t _r	--	210	250	
Turn-Off Delay Time		t _{d(off)}	--	3700	4800	
Turn-Off Fall Time		t _f	--	2000	2600	

Notes:

- pulse test: PW ≤ 300μS, duty cycle ≤ 2%
- For DESIGN AID ONLY, not subject to production testing.
- Switching time is essentially independent of operating temperature.

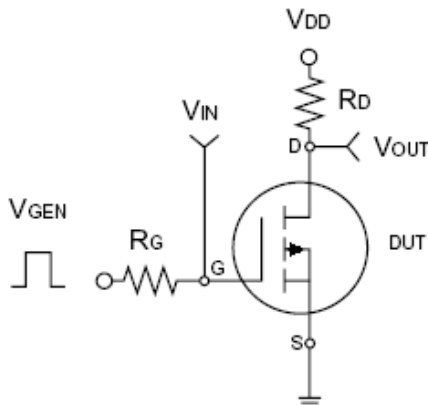
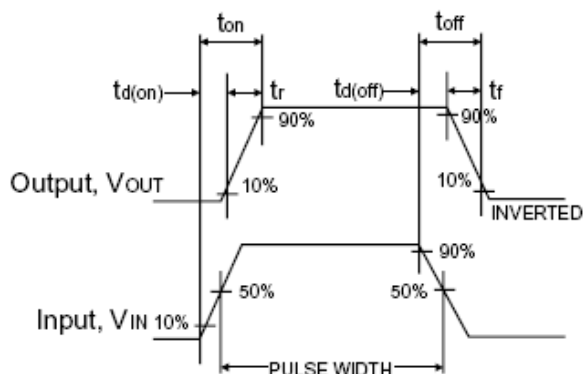

Switching Test Circuit

Switchin Waveforms

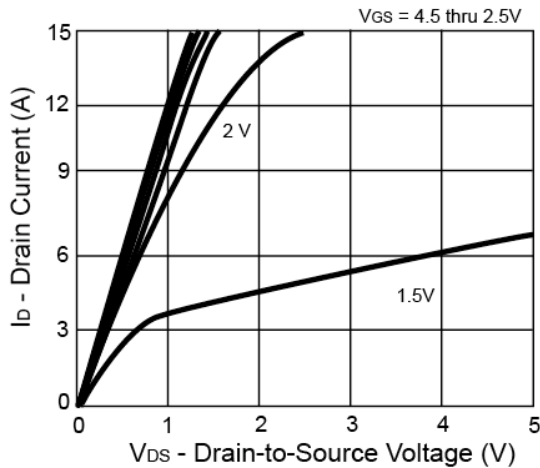
Electrical Characteristics Curve (Ta = 25°C, unless otherwise noted)

Output Characteristics

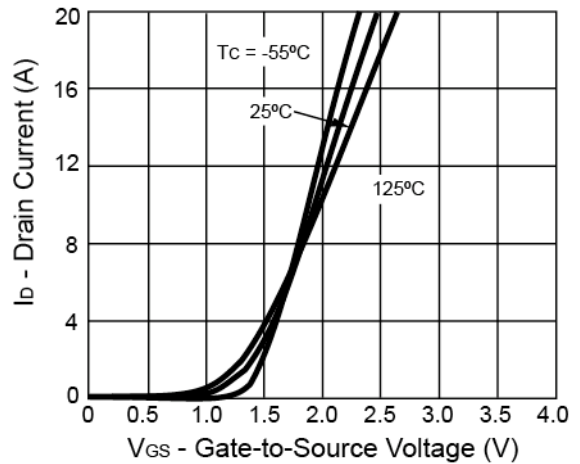

Transfer Characteristics



On-Resistance vs. Drain Current

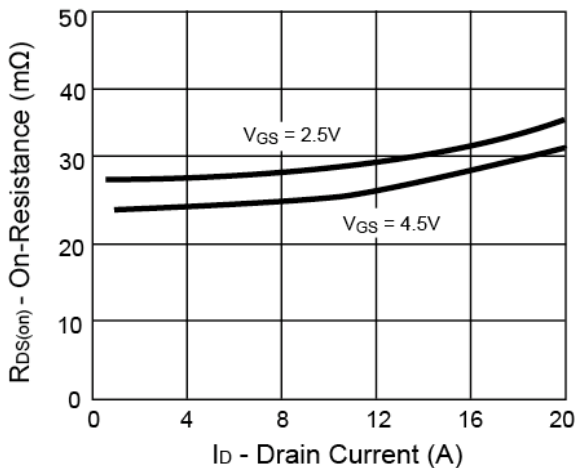

Gate Charge

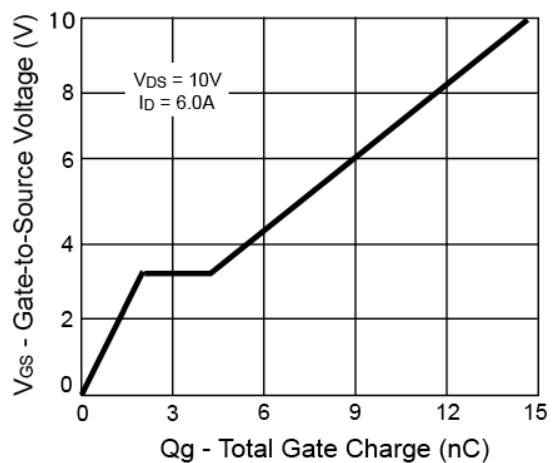

On-Resistance vs. Junction Temperature

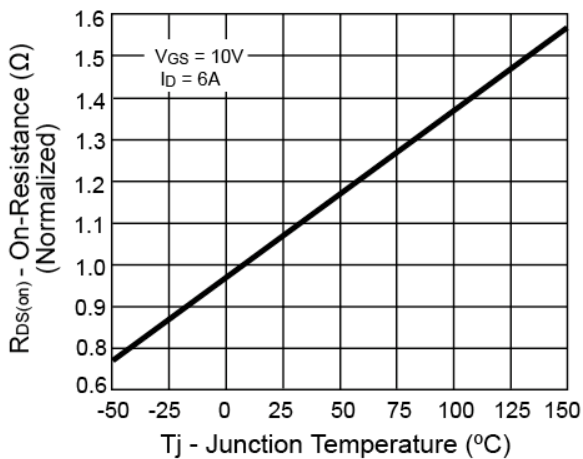

Source-Drain Diode Forward Voltage

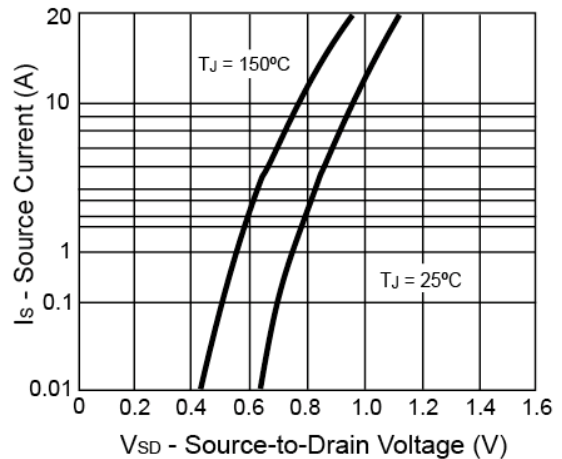

Electrical Characteristics Curve (Ta = 25°C, unless otherwise noted)

On-Resistance vs. Gate-Source Voltage

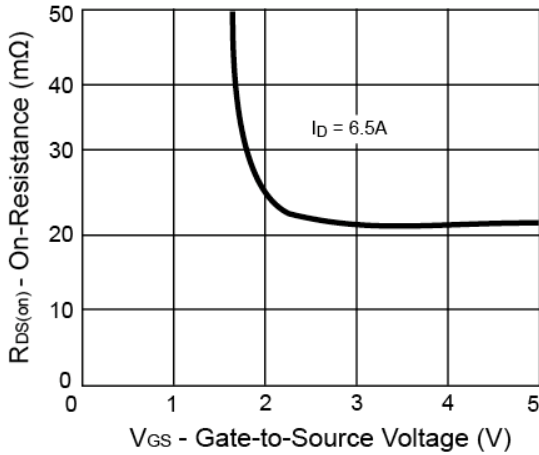

Threshold Voltage

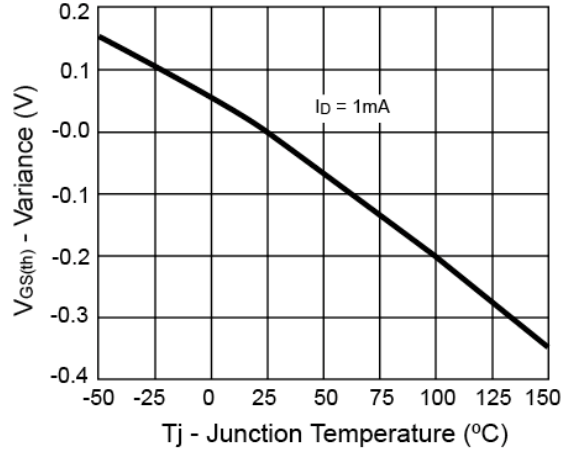

Single Pulse Power

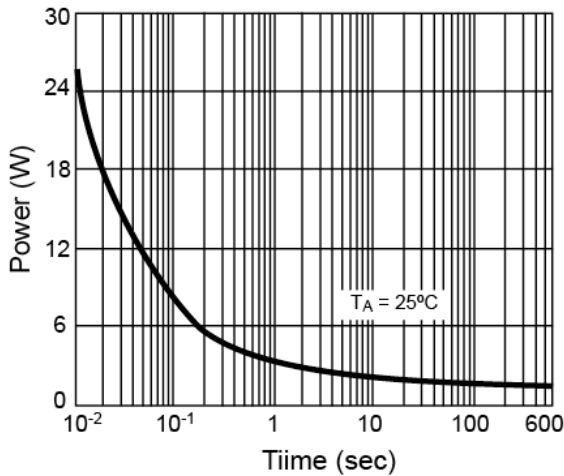

Normalized Thermal Transient Impedance, Junction-to-Ambient

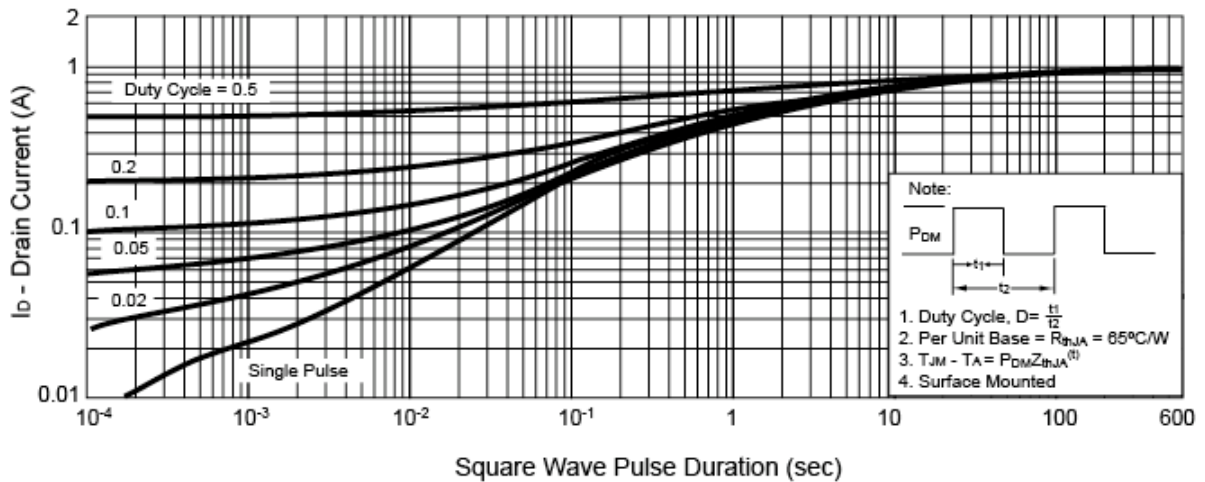

TSSOP-8 Mechanical Drawing

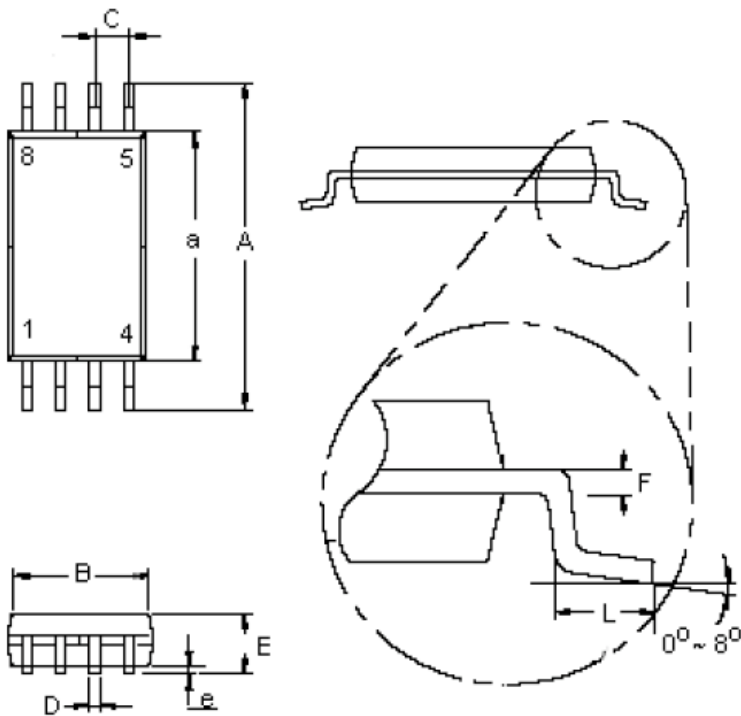

TSSOP-8 DIMENSION				
DIM	MILLIMETERS		INCHES	
	MIN	MAX	MIN	MAX
A	6.20	6.60	0.244	0.260
a	4.30	4.50	0.170	0.177
B	2.90	3.10	0.114	0.122
C	0.65 (typ)		0.025 (typ)	
D	0.25	0.30	0.010	0.019
E	1.05	1.20	0.041	0.049
e	0.05	0.15	0.002	0.009
F	0.127		0.005	
L	0.50	0.70	0.020	0.028

Marking Diagram

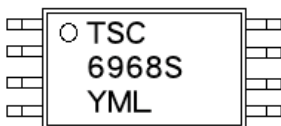

Y = Year Code

M = Month Code for Halogen Free Product

O =Jan **P** =Feb **Q** =Mar **R** =Apr

S =May **T** =Jun **U** =Jul **V** =Aug

W =Sep **X** =Oct **Y** =Nov **Z** =Dec

L = Lot Code



TSM6968SD

20V Dual N-Channel MOSFET w/ESD Protected

Notice

Specifications of the products displayed herein are subject to change without notice. TSC or anyone on its behalf, assumes no responsibility or liability for any errors or inaccuracies.

Information contained herein is intended to provide a product description only. No license, express or implied, to any intellectual property rights is granted by this document. Except as provided in TSC's terms and conditions of sale for such products, TSC assumes no liability whatsoever, and disclaims any express or implied warranty, relating to sale and/or use of TSC products including liability or warranties relating to fitness for a particular purpose, merchantability, or infringement of any patent, copyright, or other intellectual property right.

The products shown herein are not designed for use in medical, life-saving, or life-sustaining applications. Customers using or selling these products for use in such applications do so at their own risk and agree to fully indemnify TSC for any damages resulting from such improper use or sale.



Компания «ЭлектроПласт» предлагает заключение долгосрочных отношений при поставках импортных электронных компонентов на взаимовыгодных условиях!

Наши преимущества:

- Оперативные поставки широкого спектра электронных компонентов отечественного и импортного производства напрямую от производителей и с крупнейших мировых складов;
- Поставка более 17-ти миллионов наименований электронных компонентов;
- Поставка сложных, дефицитных, либо снятых с производства позиций;
- Оперативные сроки поставки под заказ (от 5 рабочих дней);
- Экспресс доставка в любую точку России;
- Техническая поддержка проекта, помощь в подборе аналогов, поставка прототипов;
- Система менеджмента качества сертифицирована по Международному стандарту ISO 9001;
- Лицензия ФСБ на осуществление работ с использованием сведений, составляющих государственную тайну;
- Поставка специализированных компонентов (Xilinx, Altera, Analog Devices, Intersil, Interpoint, Microsemi, Aeroflex, Peregrine, Syfer, Eurofarad, Texas Instrument, Miteq, Cobham, E2V, MA-COM, Hittite, Mini-Circuits, General Dynamics и др.);

Помимо этого, одним из направлений компании «ЭлектроПласт» является направление «Источники питания». Мы предлагаем Вам помощь Конструкторского отдела:

- Подбор оптимального решения, техническое обоснование при выборе компонента;
- Подбор аналогов;
- Консультации по применению компонента;
- Поставка образцов и прототипов;
- Техническая поддержка проекта;
- Защита от снятия компонента с производства.



Как с нами связаться

Телефон: 8 (812) 309 58 32 (многоканальный)

Факс: 8 (812) 320-02-42

Электронная почта: org@eplast1.ru

Адрес: 198099, г. Санкт-Петербург, ул. Калинина, дом 2, корпус 4, литера А.