

QPO-1 Output Ripple Attenuation SiP

Description:

The QPO-1 output ripple attenuator SiP uses active filtering to reduce output the periodic and random disturbances (PARD) over 30 dB from 500 Hz to 500 kHz and it can be extended down to 50 Hz with additional capacitance added to the VREF pin⁽¹⁾. The QPO-1 operates over a voltage range from 3 to 30 Vdc and supports load currents as high as 10 A. Output regulation is maintained with remote sense or trim adjustment of the power supply. The closed loop architecture improves transient response and ensures quiet point-of-load regulation when used in conjunction with the power supply's control loop or trim node.

The waveforms in Figure 2 show the QPO-1's ability to both filter a converter's output ripple and maintain a constant output voltage during a load transient. The input voltage of the QPO-1 (dark blue) shows varying amplitude and frequency PARD before and during the load transient, but the QPO-1 output voltage (light blue) remains relatively unaffected. The converter used is a Vicor Mini, 48 Vdc to 5 Vdc converter (Model number: V48B5C200BN).



Figure 1 - QPO-1LZ (~1 in² area)

Features:

- > 30 dB PARD attenuation, 500 Hz to 500 kHz
- 3 - 30 V_{DC} operating range
- 10A rating
- Supports precise point-of load regulation
- Up to 99% efficiency
- User selectable performance optimization for attenuation, power dissipation, and transient response
- 25.3 x 25.3 x 5.0 mm Lidded SiP (System-in-Package)
- 24.9 x 24.9 x 4.4 mm Open-frame SiP
- Low profile LGA package
- Closed control loop improves transient response of most DC-DC converters and power supplies
- Reduces required number of output capacitors to support dynamic loads.

Applications

- Telecom Base Stations
- Point of Load Power Systems
- Sensors Requiring Low Noise Power
- Medical Instrumentation

QPO-1 Performance

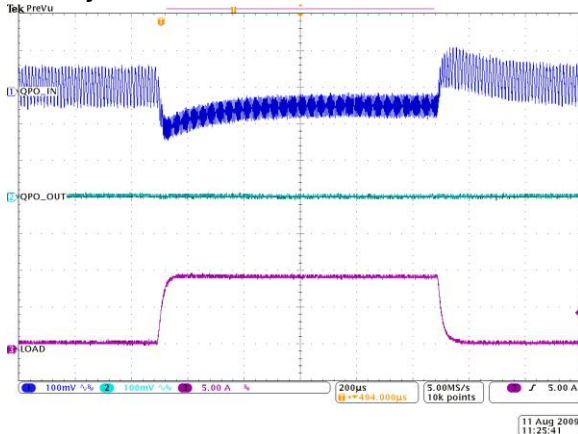

Figure 2 - PARD and Transient Attenuation during a 1A to 10A load step (~1A/µs).

Typical Application

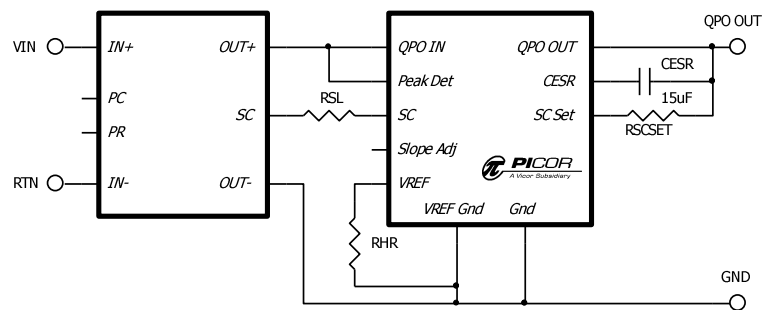

Figure 3 - Typical Application: SC/Trim supports applications that don't require remote sense.

Note 1: For off-line supplies, 20 dB of attenuation can be achieved down to 50 Hz with additional capacitance (CHR) added from the VREF pin to the REFVND pin.

Absolute Maximum Ratings – Exceeding these parameters may result in permanent damage to the product.

Input Voltage, QPO IN, PEAK IN to GND, REFGND, continuous	-0.5 to 33 Vdc
Input Voltage, QPO IN, PEAK IN to GND, REFGND, 100ms transient	-0.5 to 40 Vdc
Reference Voltage, VREF to GND, REFGND, continuous	-0.5 to 33 Vdc
QPO IN to QPO OUT, no internal current limiting ⁽²⁾	15 Adc
Power dissipation, @ 10 A ⁽³⁾	4 W
Operating temperature - T _A	-40 to 125 °C
Thermal resistance - R _{θJA} , using PCB layout in Figure 23	22 °C/W
Thermal resistance - R _{θPCB}	4 °C/W
Storage temperature, JEDEC Standard J-STD-033B	-55 to 125 °C
Reflow temperature, 20 s exposure	245 °C
ESD, Human body model (HBM)	-4000 to 4000 V

Electrical Characteristics – Parameter limits apply over the operating temp. range, unless otherwise noted.

Parameter	Notes	Min	Max	Units	
Operating load current range	Minimum load required for proper operation.	0.03	10	Adc	
Output voltage range	Continuous	3.0	30	Vdc	
Headroom voltage range (VHR)	See applications details for setting	225	525	mVdc	
Transient response voltage droop, di/dt > 1A/μs ⁽⁴⁾	ΔIOUT = 2 A	VHR = 375mV @ 100mA, CIN = 200uF		50	mVdc
	ΔIOUT = 10 A	VHR = 375mV @ 100mA, CIN = 1500uF		50	mVdc
Output noise	Input PARD = 100mVpp, 50 – 500kHz With CHR ⁽¹⁾ = 25uF			10	mVpp
				5	mVrms
SC output current accuracy	See applications details for setting	-1	+1	%	
Input bias current	Input current from QPO IN to GND		60	mA	

Note 2: User must protect load path and limit steady state load current to be less than the absolute maximum of 15A.

Note 3: See Figure 18 for the QPO-1's power de-rating curve.

Note 4: For faster current transients an additional input capacitor (CIN), between QPO IN and GND, will be required to maintain a minimal voltage drop.

Pad Descriptions

Pad Number	Name	Description	LGA Pattern (Top View)
1, 19, 20	GND	Common ground	
2	SLOPE ADJ	RSA resistor connection that sets the slope of the headroom voltage adjustment vs. load current (mV/A)	
3	VREF	Reference of the active filter that determines the QPO OUT voltage	
4	REFGND	Ground reference for the VREF pin (critical low noise connection, not internally connected to GND)	
5	CESR	Active filter compensation capacitor connection	
6	SC SET	RSCSET resistor connection that programs the SC trim control current	
7, 8, 9, 10, 17	QPO OUT	Output pins	
11, 12, 13, 14, 18	QPO IN	Input pins (critical thermal path to remove heat from the package, see PCB suggested layout Figure 23)	
15	PEAK IN	Peak Detector Input	
16	SC	Current source used to drive the SC/Trim pin of the power source	

Ordering Information

Part Number	Description
QPO-1LZ ⁽⁵⁾	QPO-1 LGA Package, RoHS Compliant
QPO-1LZ-01	QPO-1 LGA Package, RoHS Compliant, Open Frame Package

Note 5: QPO-1LZ is a non-hermetically sealed package. Please read the "Post Solder Cleaning" section on page 16.

Product Highlights

Picor's QPO-1 output ripple attenuator System-in-a-Package (SiP) provides the user with features that can optimize the performance of the product to meet their system needs. The QPO-1 uses active filtering to achieve greater than 30 dB attenuation of periodic and random deviation (PARD) over the frequency range of 1 kHz to 500 kHz. For converters running off-line, with greater low frequency output ripple, attenuation can be extended to be greater than 20 dB at 50 Hz by connecting a 25 μ F capacitor between the VREF and REFVND pins.

The QPO-1 operates over an output voltage range of 3 to 30 Vdc and is compatible with most switching power supplies and DC-DC converters. Remote Sense or SC/Trim can be selected to maintain output voltage regulation at the load. The SC/Trim feature will adjust the converter output voltage to compensate the headroom voltage drop of the filter if remote sense is not available or not preferred. The SC function works with converters that have a positive reference type trim adjustment feature.

The QPO-1 can be used in an open loop configuration without either remote sense or SC/trim. In this mode of operation the QPO-1 will still provide greater than 30 dB of ripple and noise attenuation, but DC errors will not be corrected once the converter and headroom voltages are established, resulting in reduced load regulation and transient performance.

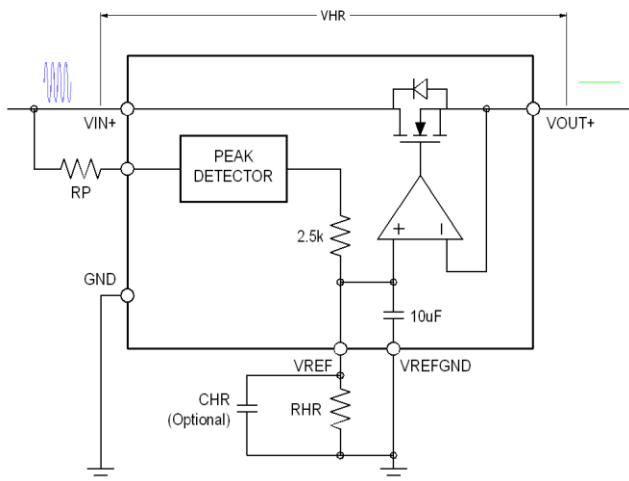

Figure 4 - QPO-1 Active Filter Block Diagram

The QPO-1's closed loop architecture greatly improves load transient response of the converter while ensuring steady-state precise point of load voltage regulation.

The headroom setting of the QPO-1 filter dramatically reduces the capacitance needed at the converter output to provide equivalent transient performance and ripple reduction. Figure 2 demonstrates how the QPO-1 can be an

ideal solution for noise sensitive applications providing ripple and noise reduction and improved output regulation with high transient loads. More information about the QPO-1's transient abilities can be found on Picor's website:

http://www.vicorpower.com/webdav/site/com.vicor.www/s_hared/documents/whitepapers/wp_load_capacitance.pdf

QPO-1 Functional Description

PARD Attenuation:

The QPO-1 uses a closed-loop, active filtering technique to provide differential attenuation of PARD (Periodic and Random Deviations), typically associated with a DC to DC converter's output voltage. The active filter provides attenuation from lower frequencies up to 500 KHz. The lower frequency range can be extended by adding an external by-pass cap across the RHR resistor, as shown in Figure 4.

Active attenuation is achieved by using a FET as a variable resistor that can dynamically change its resistance depending on the voltage difference between the input voltage and the QPO-1's internal reference voltage. When the difference is lower, the FET's resistance is reduced, lowering the overall voltage drop across the QPO-1. When higher, the resistance is increased, increasing the voltage drop across the QPO-1. The QPO-1's output voltage is the same as the voltage that is on its VREF pin.

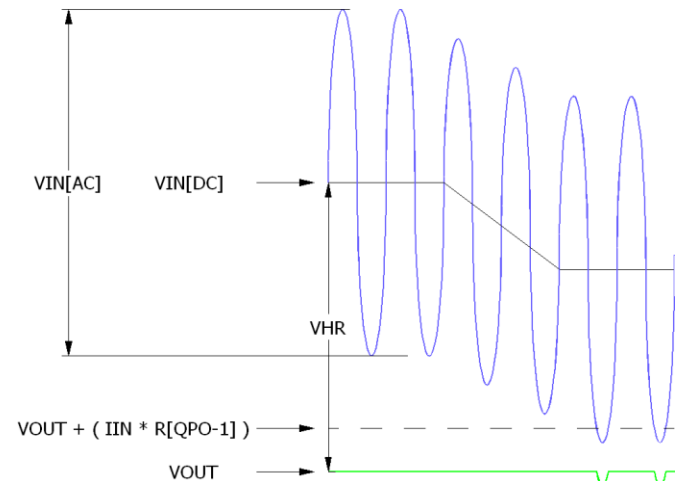

Figure 5 - Attenuation Headroom

There is a finite minimum resistance of about 10 m Ω between QPO IN and QPO OUT that determines the minimum voltage drop of the QPO-1. At a 10 A load, this would mean a minimum 100 mV DC drop across QPO-1 without setting any additional headroom for attenuating ripple. In Figure 5 this voltage is defined as " $V_{OUT} + (I_{IN} * R_{QPO-1})$ ". Figure 5 illustrates that as the DC headroom voltage gets reduced, the difference between VIN[DC] and VOUT, the input ripple eventually gets

passed to the output. When the negative peak of the VIN waveform goes below this minimum level, the VOUT voltage drops accordingly.

The limitation on the high end is that the voltage between QPO IN and QPO OUT cannot be greater than 30V or dissipate more than the rated power at ambient temperature. This is to insure that the QPO-1 does not get internally damaged.

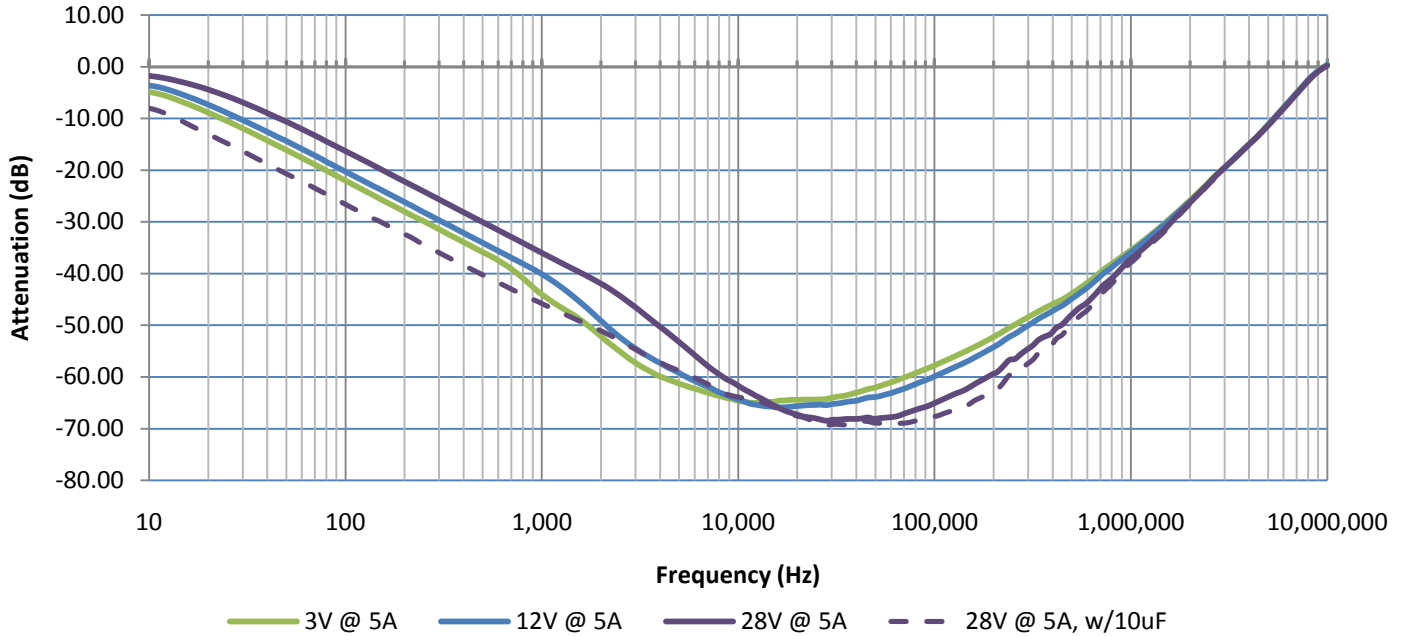

Figure 6 - PARD attenuation over the typical operating voltage range.

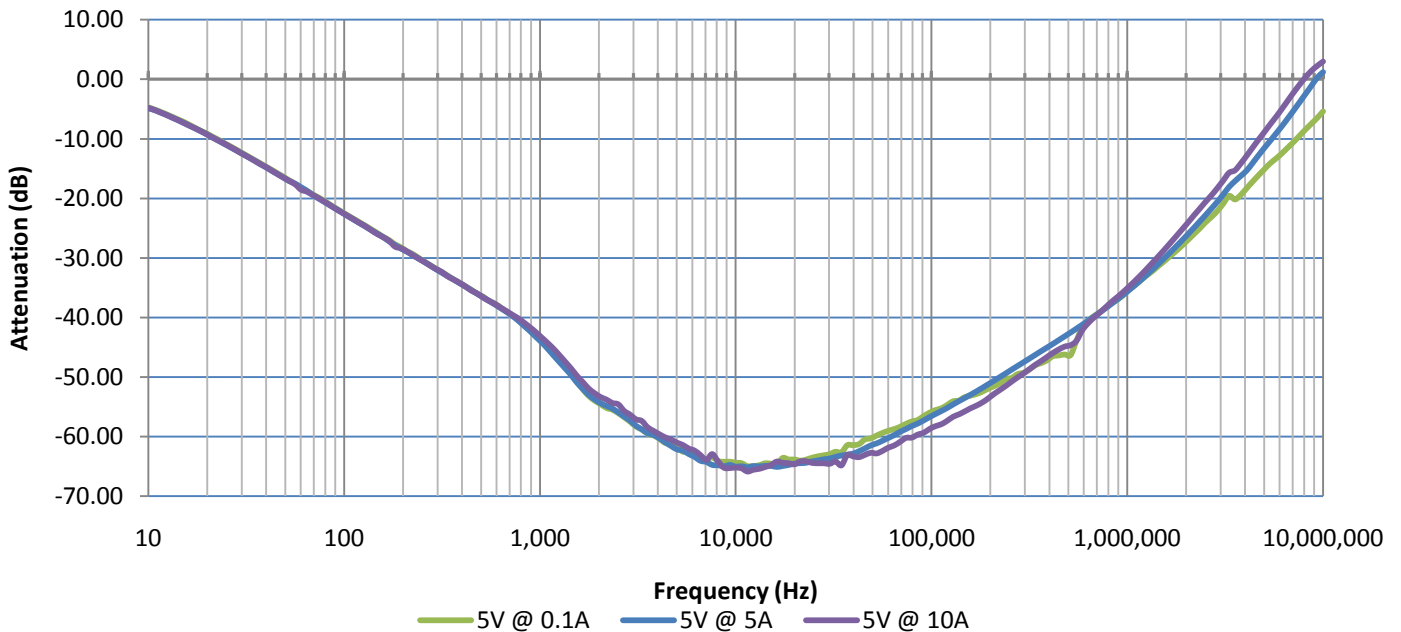

Figure 7 - PARD attenuation for a fixed voltage, light to full load.

The plots in Figure 6 show the QPO-1's PARD attenuation capabilities over a frequency range of 10Hz to 10MHz; using a 100mV_{p-p} sine wave impressed upon a DC rail with a constant 5A load. As the magnitude of the DC voltage increases, the lower frequency end of the attenuation decreases, but it can be increased with the addition of an external capacitor across

the REF pin to REF GND pin. The 28V plots (solid and dashed purple lines) are shown with and without an additional 10uF capacitor (Panasonic EEU-FC2A100 or similar) added. The plots in Figure 7 show that the QPO-1's PARD attenuation is constant over the full load range; from a light load of 100mA to the full rated load of 10A.

Built into the QPO-1 is the “peak detector” function, which is designed to adjust the static DC headroom voltage by half of the peak to peak voltage, to prevent passing a portion of the ripple voltage to the output. The filter time constant of the VREF pin determines the low frequency attenuation response of the QPO-1. The high frequency attenuation response is determined by the roll-off characteristics of the active loop.

Peak Detector:

The peak detector function is used to adapt the QPO-1’s headroom voltage in response to an increase in amplitude of converter ripple. The peak detector adds about half of the input ripple’s peak to peak value to the programmed dc value of the headroom. The increase in headroom will cause the SC circuit to source more current into the converter’s trim circuit, increasing the converter’s output voltage, as shown in Figure 8, which will compensate for the extra headroom voltage drop. The converter’s remote sense capabilities will automatically compensate for the increase in headroom.

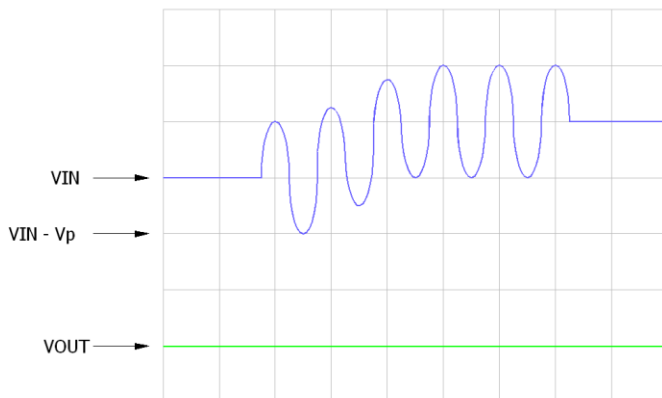

Figure 8 - Peak detector affecting the QPO-1’s output in remote sense mode.

The peak detector creates the internal reference voltage rail that gets divided down by the headroom resistor *RHR*, so a connection to the input bus must always be made. The use of *RP* to make this connection gives the user the ability to disable the peak detector, if so desired, by adding the *CP* optional capacitor between the *PEAK IN* pin and ground. The addition of this capacitor creates an RC filter network that filters out the converter’s ripple to the peak detector. If the user only wants the peak detector function enabled, then the *RP* resistor can be omitted and the *PEAK DET* pin connected with a metal trace.

Using a 1k resistor for *RP*, and a 1uF ceramic capacitor for *CP*, will attenuate the *PEAK IN* signal by 30dB or more for frequencies of 5.5 KHz or greater. This will maintain a constant headroom voltage even with variations in ripple amplitude from the converter.

Slope Adjust:

The QPO-1 has a current sensing function that creates a voltage at the Slope Adjust pin that is proportional with the load current. This feature can be used to improve the efficiency of the filter when the supply ripple amplitude reduces with increasing load, as with variable frequency DC-DC converters. By selecting the appropriate *RSA* resistor value, the slope of the headroom reduction versus load current can be set. Reducing the headroom voltage by the amount set by the *RSA* value results in reduced power dissipation in the QPO-1 when compared to a fixed headroom setting. The current sensing function also provides a power limit function that forces the filter to its minimum possible power loss if the load current approaches 15 Amps, providing a power fold-back limiting feature. The *RSA* resistor is calculated by using the following equation:

$$RSA = \frac{0.05V}{A} * \frac{\Delta IOUT}{\Delta VHR} * 2.5k$$

Where; $\Delta IOUT$ = Maximum change in load current

ΔVHR = desired change in headroom voltage over maximum load range

RSA = slope adjust resistor

The slope adjust feature can be disabled by either using a large resistor value (100k or greater) for *RSA* or by omitting this resistor entirely.

Headroom Adjust:

The *RHR* resistor is used to program the desired voltage drop across the QPO-1. This voltage must be greater than the ripple voltage that the QPO-1 is to filter, with additional voltage added for the voltage drops in the attenuation path. Like the *RP* resistor, **the *RHR* resistor must always be installed for proper operation.** The value of *RHR* can be calculated using this equation:

$$RHR = \frac{VOUT * 2.5k}{VHR}$$

Where; *RHR* = headroom setting resistor value,

VOUT = the voltage on the QPO’s output,

VHR = the target headroom voltage.

If this resistor is omitted, then the reference pin will be at the same voltage as the input pin, forcing the output pin to be the same voltage as the input pin.

SC Function:

The function of the SC circuit is to use a converter’s trim or SC (secondary control) pin to compensate for the voltage drop across the QPO-1, thereby maintaining the desired output voltage on the QPO’s output. The QPO-1’s SC circuit sources

a current into the converter's SC/Trim pin to raise the output voltage of the converter.

The current required to increase a converter's output voltage is dependent on the converter and its internal reference circuitry. The QPO-1 is designed to drive a converter which has a fixed reference voltage with a series resistor which can be offset by the injection of current into the pin. The current can be calculated using the following equation:

$$ISCSET = \frac{VHR * VRPT}{VOUT * RIN}$$

Where; *VOUT* = Nominal converter output voltage
VRPT = internal reference voltage
VHR = QPO-1's headroom voltage.
RIN = internal series resistor.

The *RSCSET* resistor is calculated by dividing the headroom voltage by *ISCSET*. The *RSCSET* equation reduces to the following:

$$RSCSET = \frac{RIN * VOUT}{VRPT}$$

Where; *VOUT* = Nominal converter output voltage
VRPT = internal reference voltage
RIN = internal series resistor.

When using one of Vicor's Micro, Mini or Maxi converters, the *RIN* = 1kΩ and the *VRPT* = 1.23V.

The *RSL* resistor, shown in Figure 3, is used to limit the amount of current the QPO-1 can source during start-up. The SC current is derived from the headroom voltage and at start-up the headroom voltage is greater than when in normal operation. This higher current can over-drive a converter to the point where an over-voltage fault can occur. *RSL* is calculated using the following equation:

$$RSL = \frac{VIN + 8V - (1.1 * VRPT)}{ISCMAX}$$

Where; *RSL* = current limiting resistor for the QPO SC circuit,
VIN = the QPO's input voltage,
VRPT = the nominal SC voltage of the converter,
ISCMAX = the current that will force a converter to have 110% of its nominal voltage on its output.

$$ISCMAX = \frac{0.1 * VRPT}{RIN}$$

Where; *ISCMAX* = the current that will force a converter to have 110% of its nominal voltage on its output.

VSC = the nominal SC voltage of the converter,
RINT = the internal series resistor of the converter's reference circuit.

Remote Sense:

Compensation for the QPO-1's voltage drop can be done using the converter's remote sense pins, if available. The on-board sensing network can be attached as is shown in Figure 10, using *RRS* and *CRS*.

QPO Applications

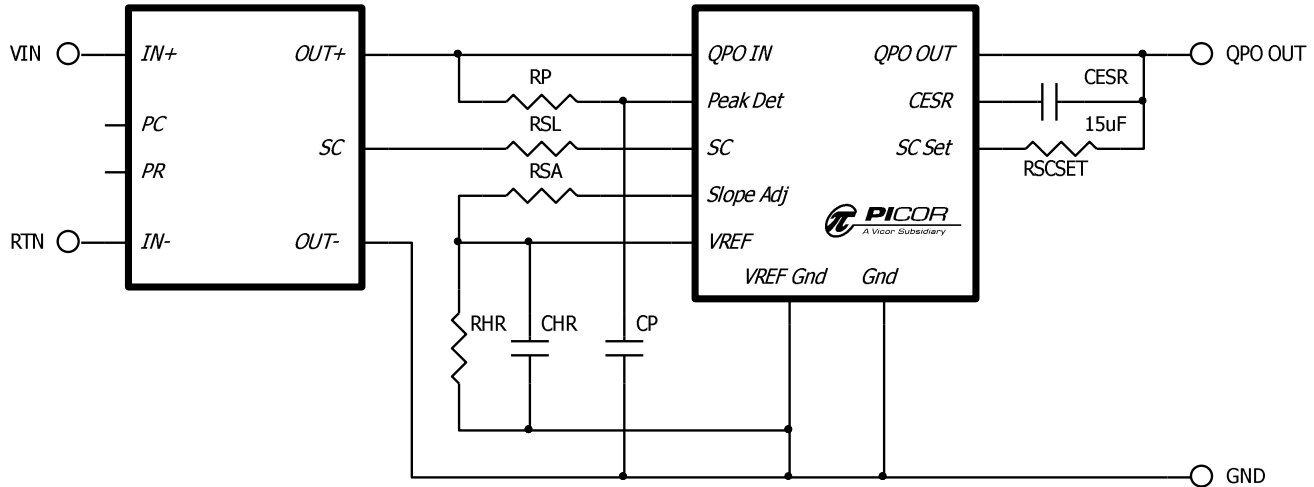

Figure 9 - QPO's output voltage regulated by SC circuit.

In Figure 9, the QPO-1's SC function is used to adapt the converter's output voltage to compensate for the headroom voltage drop across the QPO-1. The SC function sources a programmed current into the SC/Trim pin of the converter, raising its reference voltage so that the converter's output voltage is increased by the amount of the headroom voltage. The current is programmed via the *RSCSET* resistor and *RSL* is used to limit the current during start-up to prevent over-driving the converter.

Figure 10 shows the converter adapting for the QPO-1's headroom voltage drop by using its own remote sensing pins. When using remote sensing, it is recommended to use the RC

network (*RRS* and *CRS*) to provide the feedback to the positive sense pin to maintain converter stability. These values are recommended for the Vicor family of converters using short, low parasitic, connections to the point of load. They may have to be adjusted for other converters or for very long or high parasitic connections to the load.

In both circuits; *RHR*, *RP* and *CCSR* are vital components required for proper operation. *RSA*, *CP* and *CHR* are optional components that may or may not be required. The QPO-1 is not designed to be paralleled to increase the rated current limit of the filter.

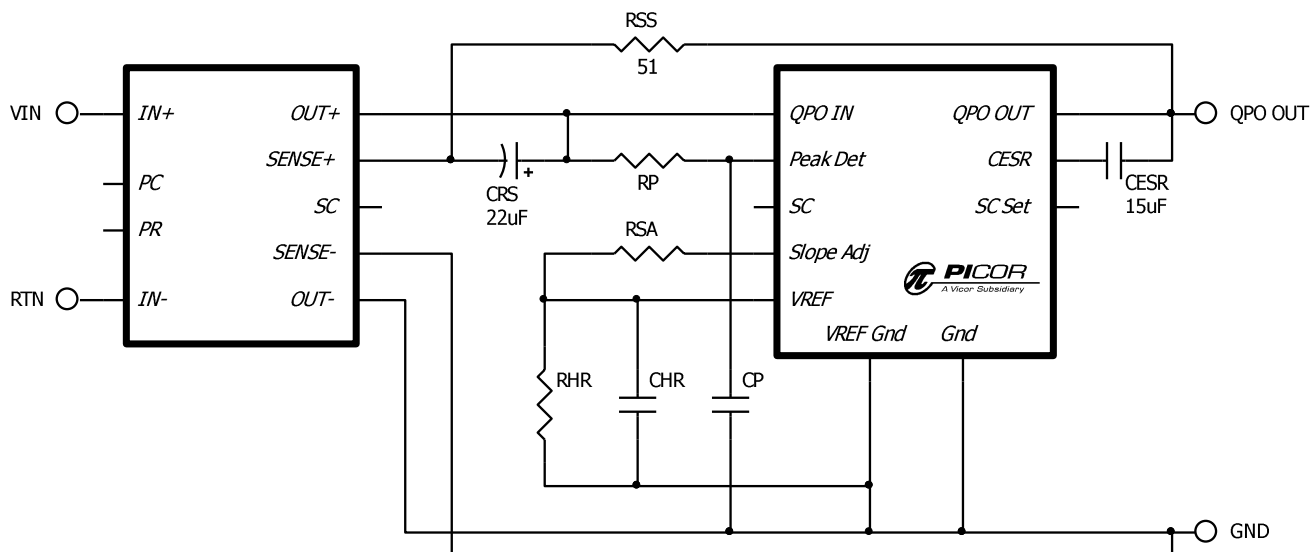

Figure 10 - QPO's output voltage regulated by remote sense.

QPO Optional Start-up Circuits

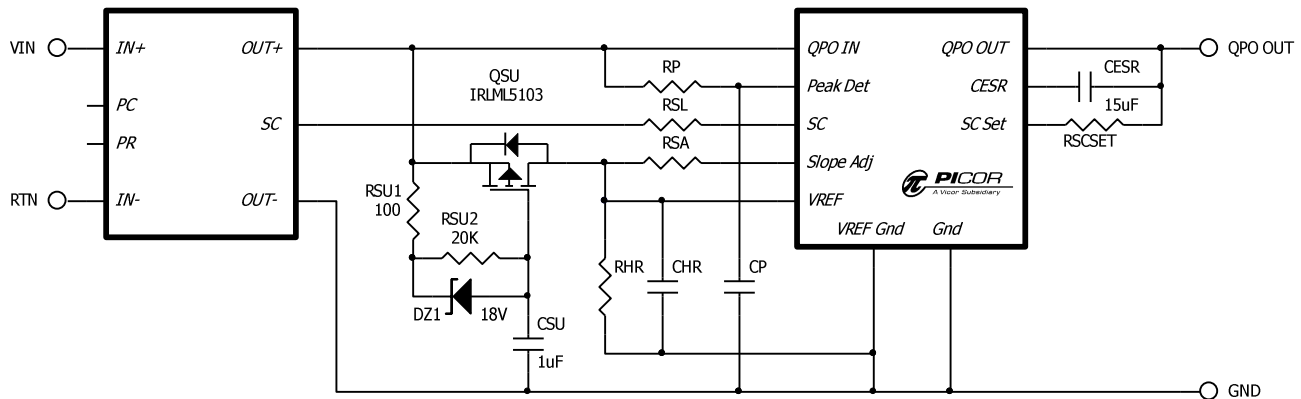

Figure 11 - Optional Start-up circuit using SC control.

In Figure 11, an optional start-up circuit has been added to a SC regulated design; comprised of components *RSU1*, *RSU2*, *DZ1*, *QSU* and *CSU*. During start-up, this circuit is used to connect the QPO-1's reference pin to its input pin. This

eliminates the delay of the output voltage reaching its proper value due to the *VREF* pin internal capacitor being charged through an internal resistor.

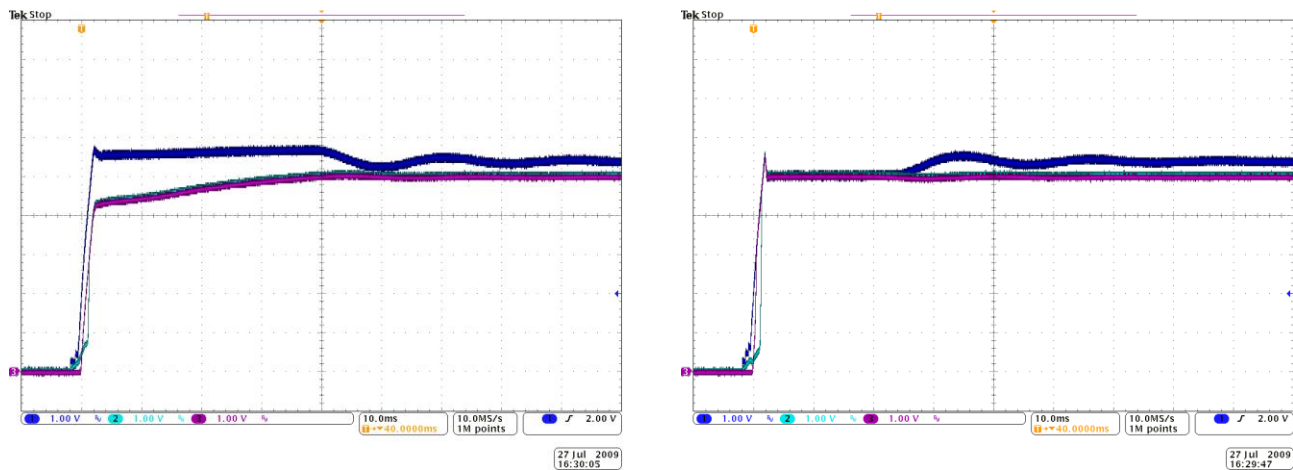

Figure 12 - Start-up waveforms; without (left) and with (right) the optional Startup circuit.

Channel 1 (blue) is *VIN+* from the converter, Channel 2 (light blue) is *QPO_{OUT}*, and Channel 3 (violet) is the QPO-1's *VREF* pin.

In the picture to the left in Figure 12 shows the start-up voltage waveforms without the optional start-up circuit, using the circuit design shown in Figure 9. The QPO-1's input voltage (the converter's output voltage) can be seen to be greater than the nominal 5V output of the converter. This is due to the QPO-1's SC circuit having greater headroom voltage during start-up and therefore over-driving the SC/Trim pin of the converter. After about 40ms, the *V_{REF}* voltage reaches its 5V pre-set limit and the converter's output voltage starts to drop, eventually steadying out at about 5.35V, the nominal output voltage plus the QPO-1's headroom voltage. The potential problem with this start-up is that the converter could fault due to its output being forced to a voltage greater than 110% of the nominal value.

For converters with lower nominal output voltages, this could be very serious condition. The addition of extra headroom capacitance, between *VREF* and *GND*, to increase the PARD attenuation at lower frequencies will increase the duration of the over-driving of the converter.

The waveforms to the right in Figure 12 are the same converter with the optional start-up circuit enabled, shown in Figure 11. Here, the *VREF* is forced to follow *QPO IN*, so *QPO OUT* follows as well. After about 25ms, the start-up circuit releases the *VREF* pin and it adjusts its value down to generate the proper headroom voltage across the QPO-1. Using this method, there is no possibility of over-driving the converter and causing a fault.

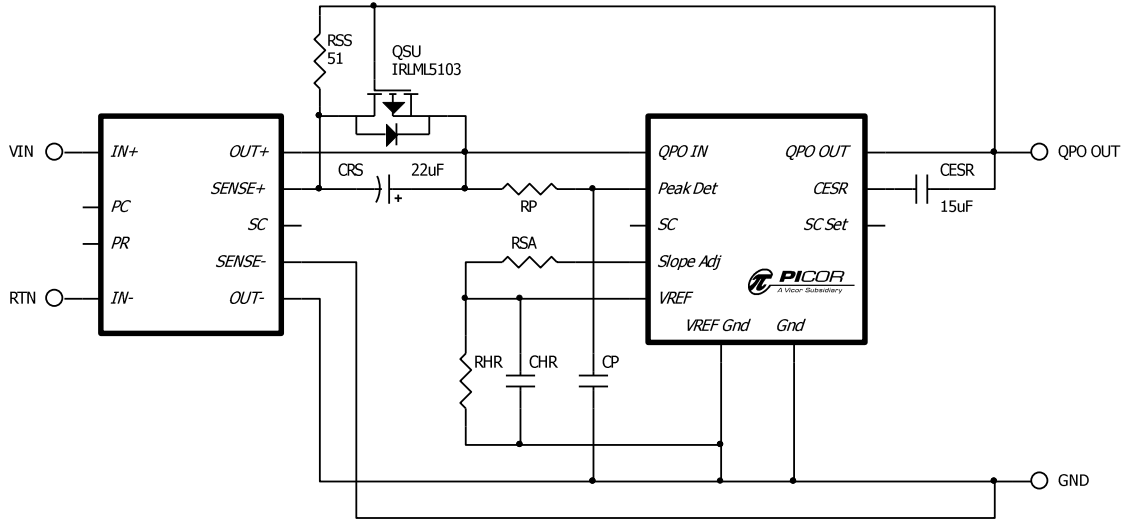

Figure 13 – Optional Start-up circuit using remote sense.

The start-up circuit shown in Figure 13 will short the converter's SENSE+ pin to the converter's positive output while the system is powering up and the filter's output

voltage is low. When the voltage difference across the filter is less than the minimum gate to source voltage of the PFET, the PFET will turn off and normal voltage sensing will start.

Using the QPO-1 with Split ±Supplies

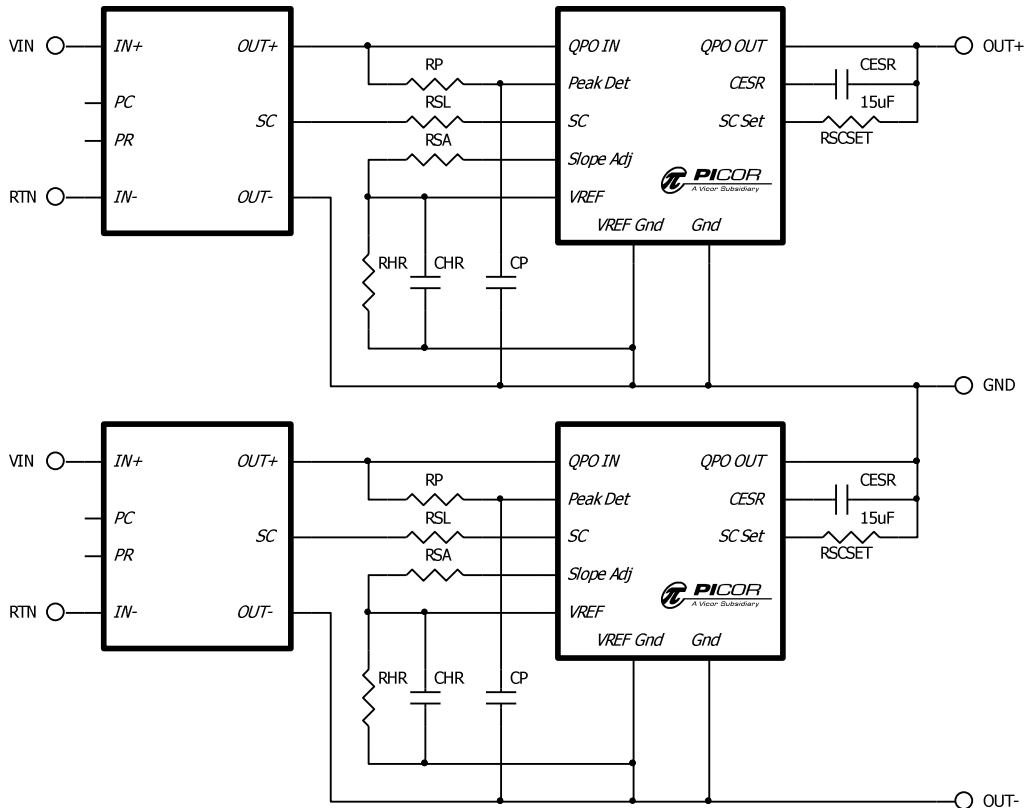

Figure 14 - ±Supply using two isolated converters.

Figure 14 shows a typically split supply configuration using two isolated dc to dc converters. Here, the QPO-1's SC circuits will compensate each converter for its own headroom voltage drop. This circuit can be adapted to be used with

converters that have output sensing pins, eliminating the SC components and the possible start-up circuitry. The QPO-1 is not recommended for use with single converters that have a split rail output.

Converter Output Voltage Trimming: Trimming "UP" using Remote Sense

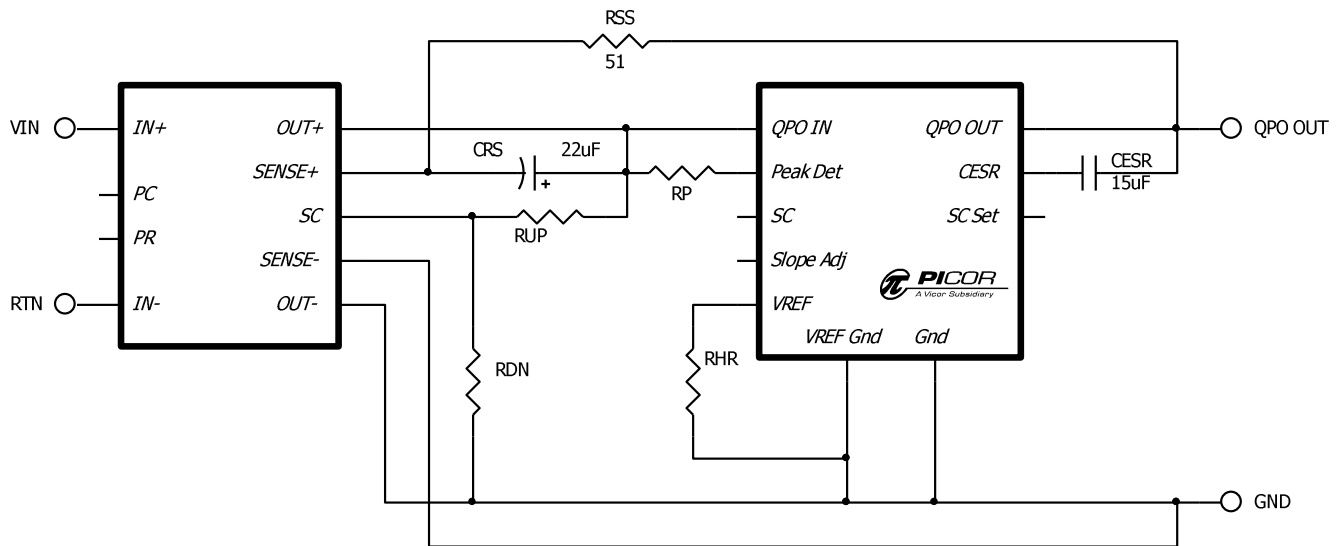

Figure 15 - Trimming a converter using remote sensing.

When trimming up a converter in a remote sense configuration, the designer must be aware that the voltage the trim-up resistor is connected to, the output of the converter, is not just the desired trim-up voltage but also the headroom voltage of the filter. The voltage programmed on the converter's SC pin is based on just the trimmed up voltage alone. To calculate the RUP resistor use the following equation:

$$RUP = \frac{RREF * (VNOM * (VOUT + VHR) - (VOUT * VREF))}{VREF * (VOUT - VNOM)}$$

Where: RUP = trim up resistor
 VNOM = nominal converter output voltage
 VOUT = desired output voltage, seen on QPO-1's output
 VHR = headroom voltage drop across the QPO-1
 VREF = converter's internal reference voltage
 RREF = converter's internal series resistor

Trimming "Down" using Remote Sense or SC control

When trimming down a converter, in either remote sense or SC control, there are no other voltage drops to take into consideration so the equation to calculate a trim down resistor is:

$$RDN = \frac{RREF * VOUT}{(VNOM - VOUT)}$$

Where: RDN = trim down resistor
 VNOM = nominal converter output voltage
 VOUT = desired output voltage, seen on QPO-1's output
 RREF = converter's internal series resistor

Trimming "UP" using SC control

When trimming up a converter using SC control, as is shown in Figure 16, the designer would calculate the trim-up resistor based on the designed trimmed up voltage without regard for the headroom voltage drop. The QPO-1's SC circuit will adapt the converter's output for the additional headroom voltage drop of the filter.

$$RUP = \frac{RREF * VOUT * (VNOM - VREF)}{VREF * (VOUT - VNOM)}$$

Where: RUP = trim up resistor
 VNOM = nominal converter output voltage
 VOUT = desired output voltage, seen on QPO-1's output
 VREF = converter's internal reference voltage
 RREF = converter's internal series resistor

Calculating RSCSET

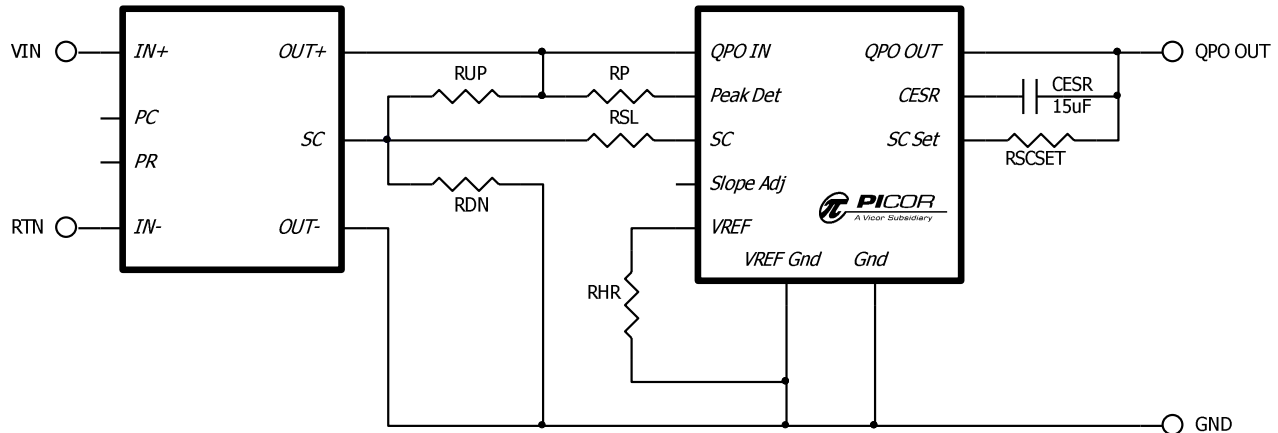

Figure 16 – Trimming a converter using SC control.

With a Trim up resistor

Once the value of the trim-up resistor is known, the SCSET resistor can be calculated using the following equation:

$$RSCSET = \frac{VHR}{ISC}$$

Where: $RSCSET$ = ISC programming resistor

VHR = QPO-1's headroom voltage drop

ISC = current sourced into the SC/Trim pin of the converter to adapt its output voltage for the headroom voltage drop of the QPO-1

ISC is the current generated by the QPO-1 that, in addition with the current from the RUP resistor, adapts the converter's SC pin to the proper voltage to generate a trimmed up output voltage plus the QPO-1's headroom voltage. ISC can be calculated by subtracting the RUP current from the total current required by the SC reference pin.

$$ISC = ITOT - IUP$$

Where: ISC = QPO-1 generated current

$ITOT$ = Total current required by the SC reference for trimming

IUP = current provided by the trim up resistor

$ITOT$ can be calculated by subtracting the original reference voltage of the SC pin from the trimmed up value, VSC , and then dividing by the series reference resistor. VSC can be calculated by dividing the converter's output voltage ($VOUT+VHR$) by the overall gain of the converter, $VNOM/VREF$. IUP is the difference in voltage between the converter's output and the converter's SC voltage, divided by the RUP resistor.

$$ITOT = \frac{VSC - VREF}{RREF}$$

$$IUP = \frac{VOUT + VHR - VSC}{RUP}$$

$$VSC = \frac{VREF(VOUT + VHR)}{VNOM}$$

Where: $ITOT$ = Total current required by the SC reference for trimming

VSC = converter's SC/Trim pin voltage

IUP = current provided by the trim up resistor

Combining these equations, the equation for $RSCSET$ becomes:

$$RSCSET = \frac{VHR * RREF * RUP}{RUP(VSC - VREF) - RREF(VOUT + VHR - VSC)}$$

With a Trim down resistor

The addition of a trim-down resistor sinks current out of the SC pin of the converter, lowering the voltage on the pin due to the voltage drop across the internal series resistor. The SC circuit of the QPO must now source current into the RDN resistor to reduce the amount of current being sourced by the converter's SC circuit and raise the voltage on the converter's SC pin to increase the converter's output voltage.

The current required from the QPO is the difference in current between what is being sunk through the *RDN* resistor and what is being sourced by the converter's SC circuit.

$$ISC = IDN - I$$

Where: *I* = current being sourced by the converter's SC circuit
IDN = current sunk by the trim down resistor
ISC = current required from the QPO

To calculate *IDN* and *I* you need to first calculate the voltage on the converter's SC pin, *VSC*.

$$VSC = \frac{VREF(VOUT + VHR)}{VNOM}$$

Where: *VSC* = voltage on SC pin
VNOM = the converter's nominal output voltage
VHR = the voltage drop across the filter
VREF = the converter's internal reference voltage

IDN and *I* can be calculated using the following equations:

$$IDN = \frac{VSC}{RDN}$$

$$I = \frac{VREF - VSC}{RREF}$$

RSCSET is calculated by dividing the headroom voltage drop by the *ISC* current:

$$RSCSET = \frac{VHR}{ISC}$$

Or

$$RSCSET = \frac{VHR}{IDN - I}$$

Calculating the RSL resistor:

The current generated by the QPO-1's SC circuit is based on the headroom voltage drop across the filter. During start-up, before the system has had a chance to stabilize, the voltage drop across the QPO-1 can be much greater than the desired, pre-programmed, headroom voltage drop. The higher headroom voltage will generate a higher SC current and can over-drive a converter so that it faults due to an over-voltage on its output. Typically, a converter's output can be trimmed up to 110% of its nominal value.

The *RSL* resistor is used limit the amount of current the QPO-1 can source during start-up. The compliance voltage of the

QPO-1's SC circuit is about 8V greater than the QPO-1's input voltage. The maximum current the converter's SC circuit should see, based on 110% maximum trim-up, would be:

$$IMAX = \frac{VREF * 0.1}{RREF}$$

The minimum *RSL* resistor value can be calculated using this *IMAX* limit as follows:

$$RSL = \frac{VIN + 8V - VSC}{IMAX}$$

Filter Calculator Program

Picor has developed a standalone calculator, shown in Figure 17, which calculates all the required external components for a variety of filters and converters. It will work with either SC controlled or remote sensing topologies; with any of Vicor brick converters or any other manufacturers' converters with similar SC/Trim circuits.

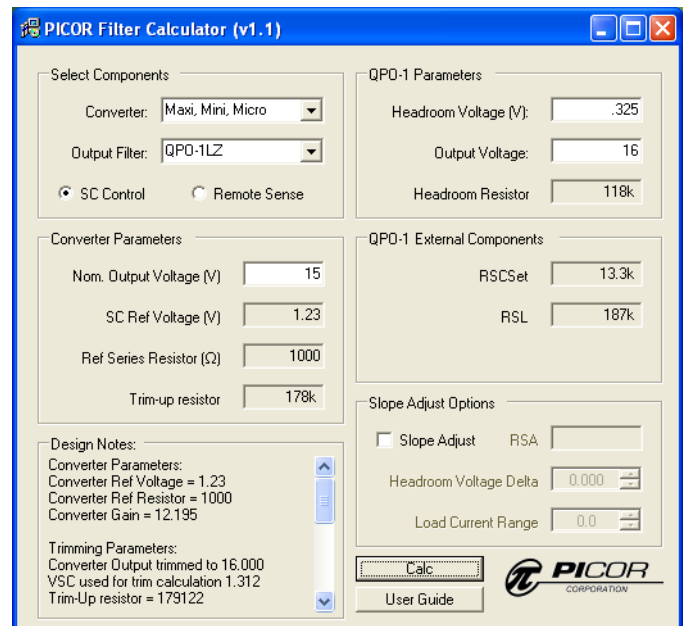

Figure 17 - Output Filter calculator

The user selects the converter type and QPO-1 filter then enters the nominal converter output voltage, the voltage on the QPO-1's output and the headroom voltage drop. The program will calculate all the resistors needed, to the closest 1% value, for this particular configuration.

This program is a Windows® based executable file and is available from your local Vicor FAE or sales representative.

QPO-1 Power De-rating Curve

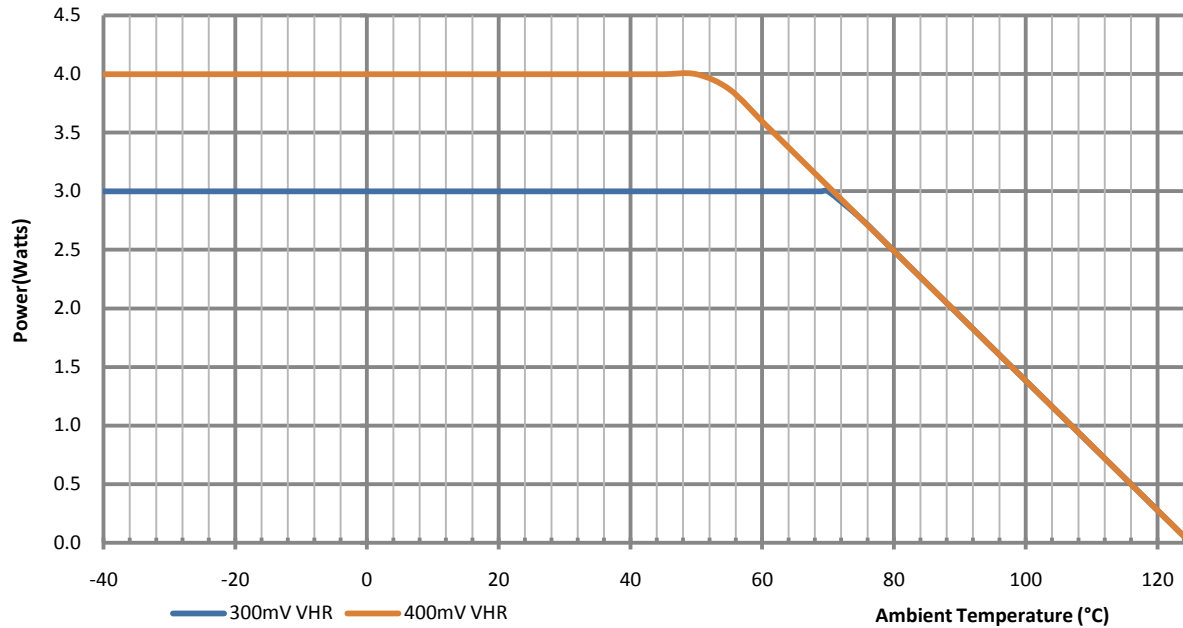

Figure 18 - QPO-1 power de-rating curve, not to exceed the 10A maximum current.

The QPO-1 is de-rated by power, assuming that the maximum recommended load current of 10A is not exceeded. In Figure 18, a 4W limit would assume 400mV of headroom at a 10A load, and would de-rate just after 50°C ambient temperature.

If the part were to have 300mV of headroom at 10A, the de-rating would start just after 70°C ambient. This de-rating curve applies to both the lidded and open-frame versions of the QPO-1.

Package Mechanicals

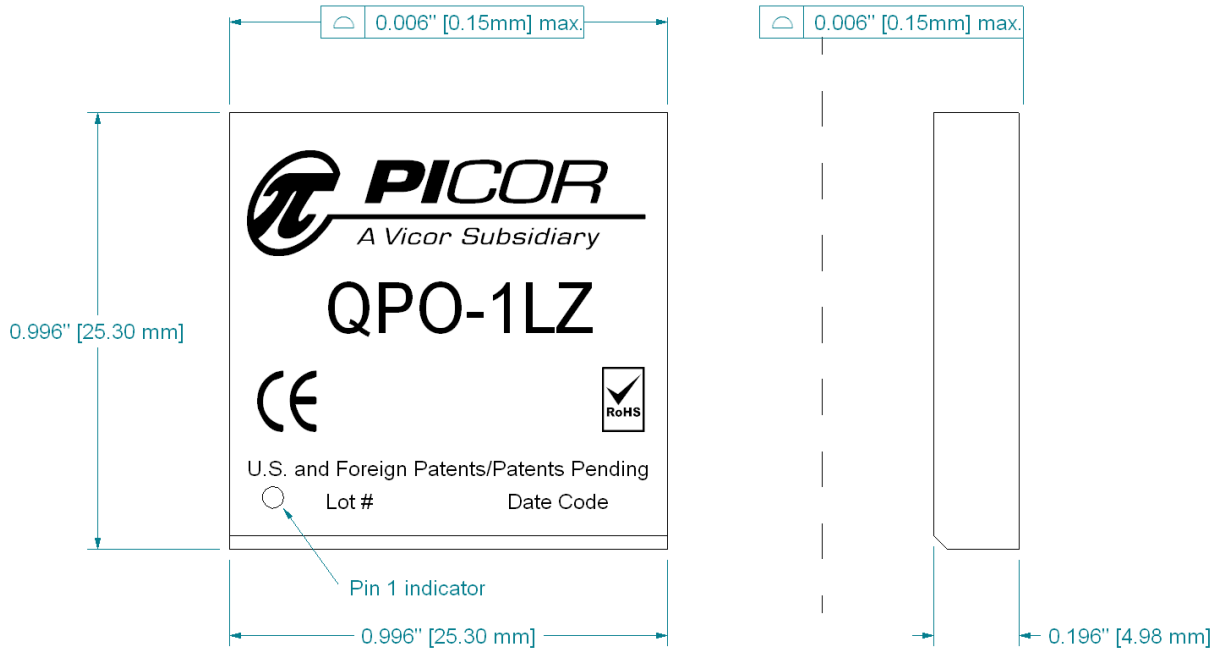

Figure 19 – QPO-1LZ package dimensions.

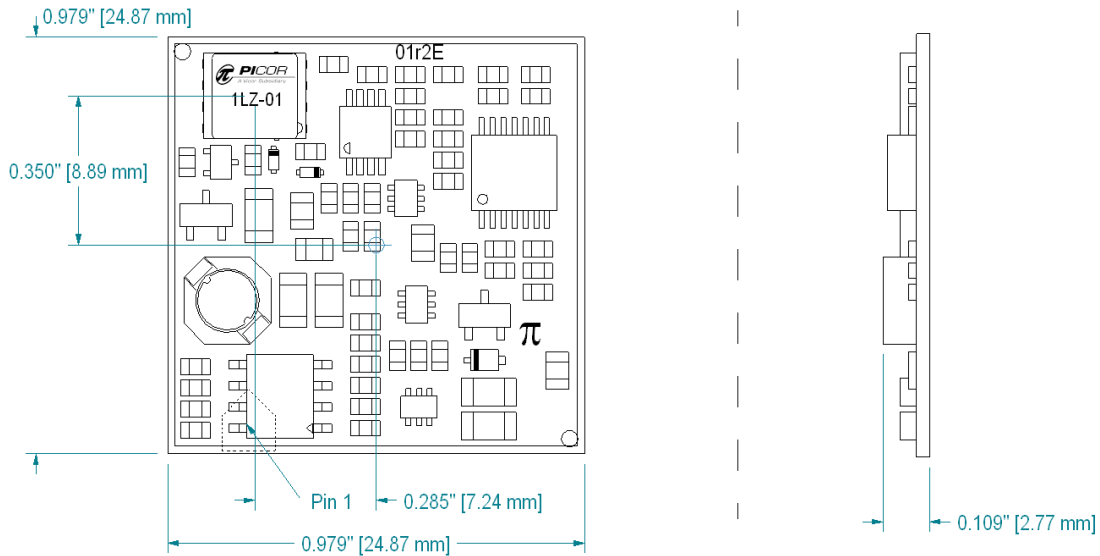

Figure 20 – QPO-1LZ-01 board dimensions and label location.

QPO Mechanical Data

Datum	Units	QPO-1LZ	QPO-1LZ-01	Notes
FITS	Failure/Billion Hrs.	386	386	FITS based on the BellCore Standard TR-332
MTBF	Million Hrs.	2.59	2.59	MTBFs based on the BellCore Standard TR-332
Weight	grams	3.1	NA	
MSL		3	3	
Peak reflow Temperature	°C/20 seconds	245	245	IPC/JEDEC J-STD-020D

Pad and Stencil Definitions:

QPO-1 LGA
Pattern
(Bottom View)

QPO-1 PCB
Receptor Pattern
(Top View)

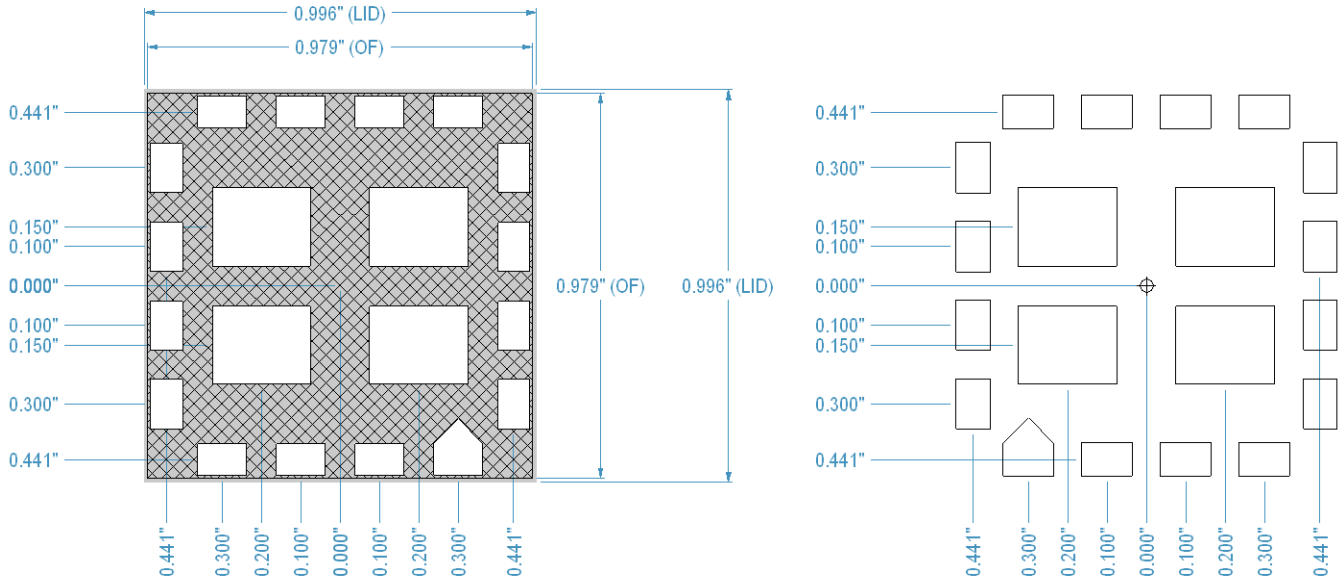

Figure 21 – Bottom view of open-frame (OF) and lidded (LID) products. (All dimensions are in inches.)

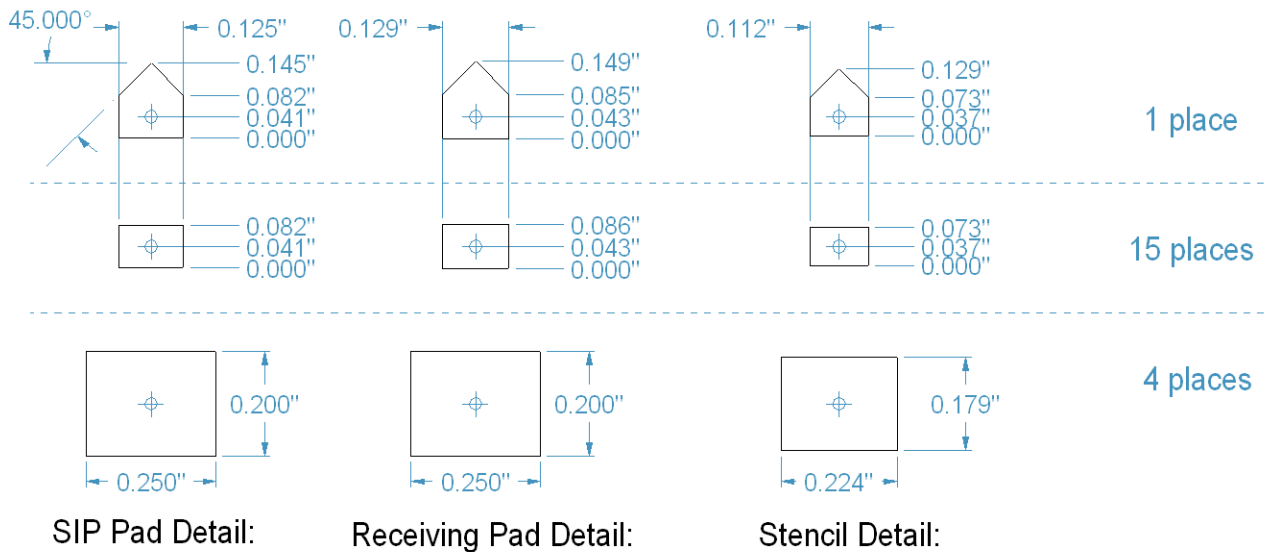

Figure 22 – Recommended receptor and stencil patterns. (All dimensions are in inches.)

Stencil definition is based on a 6mil stencil thickness, 80% of SIP pad area coverage. SIP Package dimensions are for both the Open-Frame (OF) and Lidded (LID) versions of the QPO-1.

QPO PCB Layout Recommendations:

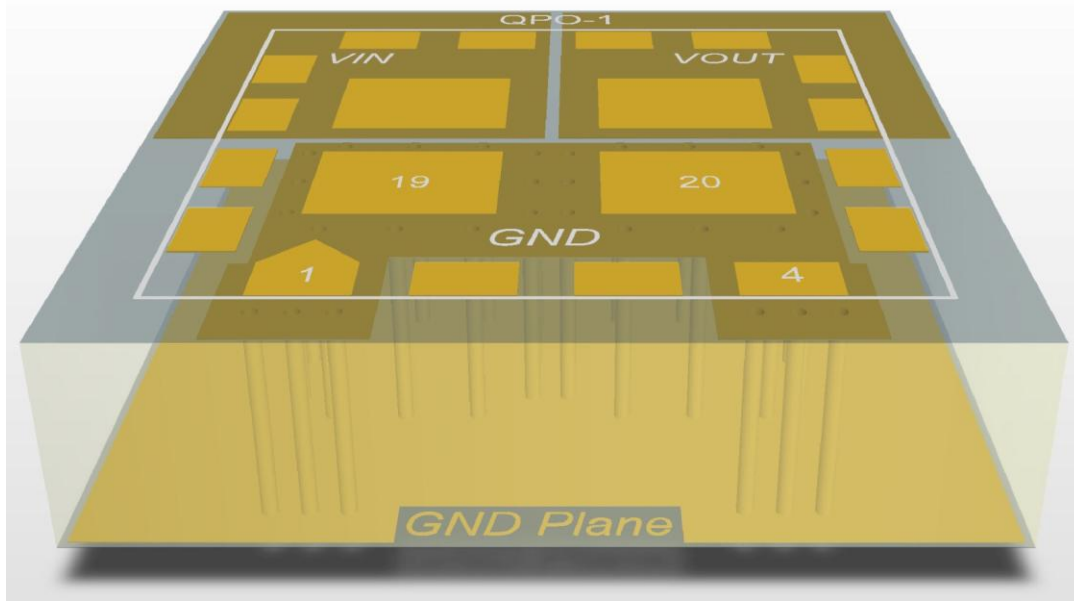

Figure 23 - 3D view of GND pad connections to GND plane layer.

PCB Layout

In order to realize the maximum PARD attenuation from the QPO-1, a proper receiving pattern and careful attenuation to PCB layout are critical. The layout in Figure 23 shows the recommended method of laying out the copper regions for the QPO-1 for maximum attenuation.

The QPO-1 has two large ground pads (19 and 20) in its center, along with a “house” shaped pad (1) in one corner. These pads are the system grounds for the QPO-1 and are connected together, along with the reference ground (4), to a solid copper plane beneath the QPO-1. The reference ground is not connected to the system ground in the QPO-1 and must be connected on the receiving artwork for proper circuit operation. This plane is then connected by vias to a ground plane layer that completely covers the whole area occupied

by the QPO-1, including the QPO’s VIN and VOUT regions underneath the QPO-1.

Post Solder Cleaning

Picor’s LZ version QP SIPs are not hermetically sealed and must not be exposed to liquid, including but not limited to cleaning solvents, aqueous washing solutions or pressurized sprays. When soldering, it is recommended that no-clean flux solder be used, as this will ensure that potentially corrosive mobile ions will not remain on, around, or under the module following the soldering process. For applications where the end product must be cleaned in a liquid solvent, Picor recommends using the QPO-1LZ-01, open-frame version of the PARD filter.

QPO-1 Evaluation Boards	
Part #	Description:
QPO-1 Eval1	Stand alone QPO-1 board that can be mounted either horizontally or vertically and has optional start-up circuit on board. User programmed headroom, SC and Slope Adjust resistors.
QPO-1 Eval3	QPO-1 with a Vicor Micro converter socket, pre-programmed with 3 SC component combinations for use with 5V, 12V or 28V converters, or can be user defined. Circuit options can be enabled through on-board switches.
QPO-1 Eval5	QPO-1 with a Vicor Mini converter socket designed to be used in either remote sense or SC controlled applications. Pre-programmed with 3 SC component combinations for use with 5V, 12V or 28V converters, or can be user defined. Circuit options can be enabled through on-board switches.

Warranty

Vicor products are guaranteed for two years from date of shipment against defects in material or workmanship when in normal use and service. This warranty does not extend to products subjected to misuse, accident, or improper application or maintenance. Vicor shall not be liable for collateral or consequential damage. This warranty is extended to the original purchaser only.

EXCEPT FOR THE FOREGOING EXPRESS WARRANTY, VICOR MAKES NO WARRANTY, EXPRESS OR LIMITED, INCLUDING, BUT NOT LIMITED TO, THE WARRANTY OF MERCHANTABILITY OR FITNESS FOR A PARTICULAR PURPOSE.

Vicor will repair or replace defective products in accordance with its own best judgment. For service under this warranty, the buyer must contact Vicor to obtain a Return Material Authorization (RMA) number and shipping instructions. Products returned without prior authorization will be returned to the buyer. The buyer will pay all charges incurred in returning the product to the factory. Vicor will pay all reshipment charges if the product was defective within the terms of this warranty.

Information published by Vicor has been carefully checked and is believed to be accurate; however, no responsibility is assumed for inaccuracies. Vicor reserves the right to make changes to any products without further notice to improve reliability, function, or design. Vicor does not assume any liability arising out of the application or use of any product or circuit; neither does it convey any license under its patent rights nor the rights of others. Vicor general policy does not recommend the use of its components in life support applications wherein a failure or malfunction may directly threaten life or injury. Per Vicor Terms and Conditions of Sale, the user of Vicor components in life support applications assumes all risks of such use and indemnifies Vicor against all damages.

Vicor's comprehensive line of power solutions includes high density AC-DC and DC-DC modules and accessory components, fully configurable AC-DC and DC-DC power supplies, and complete custom power systems.

Information furnished by Vicor is believed to be accurate and reliable. However, no responsibility is assumed by Vicor for its use. Vicor components are not designed to be used in applications, such as life support systems, wherein a failure or malfunction could result in injury or death. All sales are subject to Vicor's Terms and Conditions of Sale, which are available upon request.

Specifications are subject to change without notice.

Vicor Corporation
25 Frontage Road
Andover, MA 01810
USA

Picor Corporation
51 Industrial Drive
North Smithfield, RI 02896
USA

Customer Service: custserv@vicorpower.com
Technical Support: apps@vicorpower.com
Tel: 800-735-6200
Fax: 978-475-6715



Компания «ЭлектроПласт» предлагает заключение долгосрочных отношений при поставках импортных электронных компонентов на взаимовыгодных условиях!

Наши преимущества:

- Оперативные поставки широкого спектра электронных компонентов отечественного и импортного производства напрямую от производителей и с крупнейших мировых складов;
- Поставка более 17-ти миллионов наименований электронных компонентов;
- Поставка сложных, дефицитных, либо снятых с производства позиций;
- Оперативные сроки поставки под заказ (от 5 рабочих дней);
- Экспресс доставка в любую точку России;
- Техническая поддержка проекта, помощь в подборе аналогов, поставка прототипов;
- Система менеджмента качества сертифицирована по Международному стандарту ISO 9001;
- Лицензия ФСБ на осуществление работ с использованием сведений, составляющих государственную тайну;
- Поставка специализированных компонентов (Xilinx, Altera, Analog Devices, Intersil, Interpoint, Microsemi, Aeroflex, Peregrine, Syfer, Eurofarad, Texas Instrument, Miteq, Cobham, E2V, MA-COM, Hittite, Mini-Circuits, General Dynamics и др.);

Помимо этого, одним из направлений компании «ЭлектроПласт» является направление «Источники питания». Мы предлагаем Вам помощь Конструкторского отдела:

- Подбор оптимального решения, техническое обоснование при выборе компонента;
- Подбор аналогов;
- Консультации по применению компонента;
- Поставка образцов и прототипов;
- Техническая поддержка проекта;
- Защита от снятия компонента с производства.



Как с нами связаться

Телефон: 8 (812) 309 58 32 (многоканальный)

Факс: 8 (812) 320-02-42

Электронная почта: org@eplast1.ru

Адрес: 198099, г. Санкт-Петербург, ул. Калинина, дом 2, корпус 4, литера А.