



**1 Form A 5A
slim power relay
complies with IEC61010
reinforced insulation**

PA-N RELAYS

New



RoHS compliant

Protective construction: Sealed type (RTIII)

FEATURES

- 1. High density mounting**
5mm(W) × 20mm(L) × 12.5mm(H)
.197inch(W) × .787inch(L) × .492inch(H)
- 2. Low operating power**
Nominal operating power: 110mW
- 3. Complies with IEC61010 reinforced insulation standards**
- 4. Long Insulation distance**
 - Clearance: 5.29mm .208inch
 - Creepage distance: 5.35mm .211inch (Between contact and coil)
 - 3,000 V breakdown voltage and 6,000V surge breakdown voltage
- 5. Complies with Standard for Hazardous Location (ANSI/ISA 12.12.01)**

TYPICAL APPLICATIONS

- 1. Output relays for programmable controllers and temperature controllers**
- 2. Industrial equipment, office equipment**
- 3. Measuring devices and test equipment**

ORDERING INFORMATION

APAN 3 1

Contact arrangement

3: 1 Form A (Bifurcated)

Terminals and Nominal operating power

1: PC board terminal (110 mW)

Nominal coil voltage (DC)

03: 3V, 4H: 4.5V, 05: 5V, 06: 6V, 09: 9V, 12: 12V, 18: 18V, 24: 24V

Note: Certified by UL/C-UL and TÜV

TYPES

Contact arrangement	Nominal coil voltage	Part No.
1 Form A	3 V DC	APAN3103
	4.5 V DC	APAN314H
	5 V DC	APAN3105
	6 V DC	APAN3106
	9 V DC	APAN3109
	12 V DC	APAN3112
	18 V DC	APAN3118
	24 V DC	APAN3124

Standard packing: Tube: 25 pcs.; Case: 1,000 pcs.

* Terminal sockets available.

RATING

1. Coil data

Nominal coil voltage	Pick-up voltage (at 20°C 68°F)	Drop-out voltage (at 20°C 68°F)	Nominal operating current [±10%] (at 20°C 68°F)	Coil resistance [±10%] (at 20°C 68°F)	Nominal operating power	Max. applied voltage (at 20°C 68°F)
3 V DC	70%V or less of nominal voltage* (Initial)	5%V or more of nominal voltage* (Initial)	36.7 mA	82 Ω	110mW	120%V of nominal voltage
4.5 V DC			24.4 mA	184 Ω		
5 V DC			22.0 mA	227 Ω		
6 V DC			18.3 mA	327 Ω		
9 V DC			12.2 mA	736 Ω		
12 V DC			9.2 mA	1,309 Ω		
18 V DC			6.1 mA	2,945 Ω		
24 V DC			4.6 mA	5,236 Ω		

Note: *Pulse drive (JIS C 5442)

2. Specifications

Characteristics	Item	Specifications	
Contact	Arrangement	1 Form A (Bifurcated)	
	Contact resistance (Initial)	Max. 30 mΩ (By voltage drop 6 V DC 1A)	
	Contact material	AgNi type + Au	
Rating	Nominal switching capacity (resistive load)	5 A 250 V AC, 5 A 30 V DC	
	Max. switching power (resistive load)	1,250 VA, 150 W	
	Max. switching voltage	250 V (AC), 110 V (DC) (0.4 A)	
	Max. switching current	5 A (AC, DC)	
	Nominal operating power	110 mW	
	Min. switching capacity (Reference value)*1	1 mA 5 V DC	
Electrical characteristics	Insulation resistance (Initial)	Min. 1,000MΩ (at 500V DC) Measurement at same location as "Breakdown voltage" section.	
	Breakdown voltage (Initial)	Between open contacts	1,000 Vrms for 1min. (Detection current: 10mA.)
		Between contact and coil	3,000 Vrms for 1min. (Detection current: 10mA.)
	Surge breakdown voltage (Initial) (Between contacts and coil)*2	6,000 V	
	Operate time (at nominal voltage) (at 20°C 68°F) (Initial)	Max. 10 ms (excluding contact bounce time)	
Release time (at nominal voltage) (at 20°C 68°F) (Initial)	Max. 5 ms (excluding contact bounce time and without diode)		
Mechanical characteristics	Shock resistance	Functional	Min. 147 m/s ² (Half-wave pulse of sine wave: 11 ms; detection time: 10μs.)
		Destructive	Min. 980 m/s ² (Half-wave pulse of sine wave: 6 ms.)
	Vibration resistance	Functional	10 to 55 Hz at double amplitude of 2.5 mm (Detection time: 10μs.)
		Destructive	10 to 55 Hz at double amplitude of 3.5 mm
Expected life	Mechanical	Min. 2×10 ⁷ (at 180 times/min.)	
	Electrical	Min. 10 ⁵ (3 A 250 V AC, 30 V DC, resistive load) Min. 5×10 ⁴ (5 A 250 V AC, 30 V DC, resistive load) (at 20 times/min.)*4	
Conditions	Conditions for operation, transport and storage*3	Ambient temperature: -40°C to 90°C -40°F to 194°F ; Humidity: 5 to 85% R.H. (Not freezing and condensing at low temperature)	
	Max. operating speed	20 times/min. (at nominal switching capacity)*4	
Unit weight		Approx. 3 g .15 oz	

Notes: *1. This value can change due to the switching frequency, environmental conditions, and desired reliability level, therefore it is recommended to check this with the actual load.

*2. Wave is standard shock voltage of ±1.2×50μs according to JEC-212-1981

*3. The upper limit of the ambient temperature is the maximum temperature that can satisfy the coil temperature rise value. Refer to Usage, transport and storage conditions in NOTES.

*4. Operating frequency of 5 A 250 V AC is 6 times/min. (ON : OFF = 1 s : 9 s)

REFERENCE DATA

1. Max. switching capacity

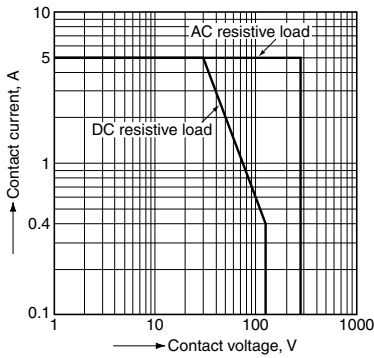

2. Life curve

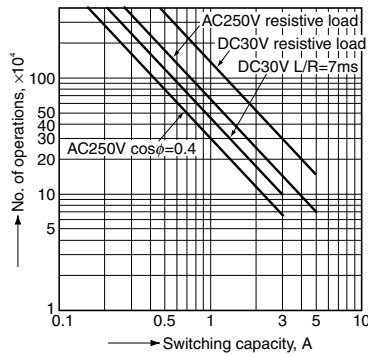

3. Coil temperature rise

Tested sample: APAN3124, 6 pcs.
 Measured portion: Inside the coil
 Ambient temperature: 20°C 68°F, 90°C 194°F (No contact current)

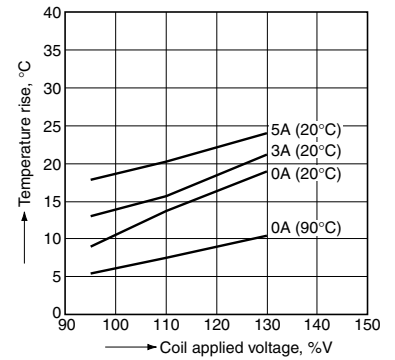

4. Operate & release time

Tested sample: APAN3124, 20 pcs.
 Measured direction: Upright

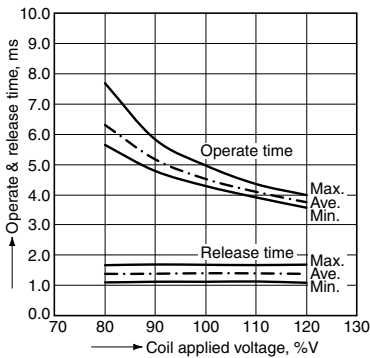

5. Ambient temperature characteristics

Tested sample: APAN3124, 6 pcs.

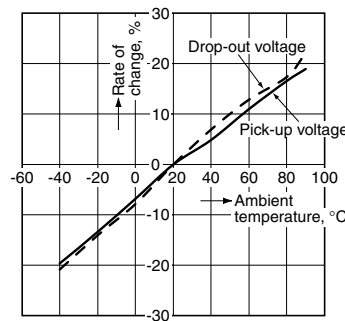

6. Malfunctional shock

Tested sample: APAN3124, 6 pcs.

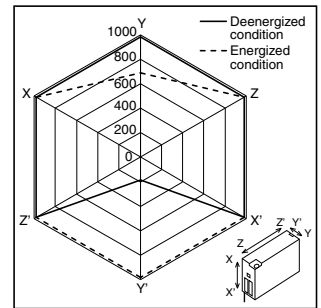

DIMENSIONS (mm inch)

The CAD data of the products with a **CAD Data** mark can be downloaded from: <http://industrial.panasonic.com/ac/e/>

CAD Data

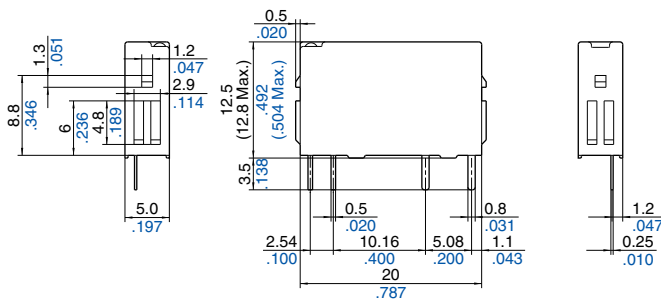

PC board pattern (Bottom view)

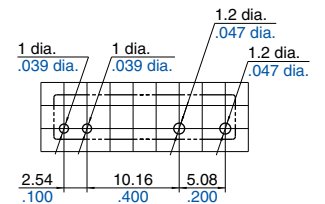

Tolerance: $\pm 0.1 \pm 0.004$

Schematic (Bottom view)

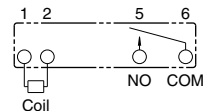

General tolerance: $\pm 0.3 \pm 0.012$

SAFETY STANDARDS

UL/C-UL (Recognized)				TÜV (Certified)			
File No.	Contact ratings	Temp.	Cycles	File No.	Contact ratings	Temp.	Cycles
E43149	5 A 250 V AC Resistive	40°C 104°F	5×10 ⁴	B16 01 13461 348	5 A 250 V AC (cosφ=1.0)	40°C 104°F	5×10 ⁴
	5 A 250 V AC Resistive	90°C 194°F	10 ⁴		5 A 250 V AC (cosφ=1.0)	90°C 194°F	10 ⁴
	5 A 30 V DC General use	40°C 104°F	5×10 ⁴		5 A 30 V DC (0 ms)	40°C 104°F	5×10 ⁴
	5 A 30V DC, 3 A 250 V AC General use	90°C 194°F	10 ⁴		5 A 30 V DC (0 ms)	90°C 194°F	10 ⁴
	3 A 250 V AC Resistive	40°C 104°F	10 ⁵		3 A 250 V AC (cosφ=1.0)	40°C 104°F	10 ⁵
	3 A 30 V DC General use	40°C 104°F	10 ⁵		3 A 30 V DC (0 ms)	40°C 104°F	10 ⁵
	B300, R300 Pilot duty	40°C 104°F	—				
E479891	Class I, Division 2, Groups A, B, C, D Hazardous Location (ANSI/ISA 12.12.01-2015, CAN/CSA C22.2 No.213-15)						

- Insulation distance (between contact and coil)
- UL/C-UL: Clearance distance: 5.29 mm **.208 inch**, Creepage distance: 5.35 mm **.211 inch**
- TÜV: Clearance distance: 5.29 mm **.208 inch**, Creepage distance: 5.35 mm **.211 inch**

NOTES

- For cautions for use, please read "GENERAL APPLICATION GUIDELINES".
- If it includes ripple, the ripple factor should be less than 5%.
- Specification values for pick-up and drop-out voltages are for the relay mounting with its terminals below.

Tested sample: APAN3124, 6 pcs.
 Ambient temperature: 20°C 68°F
 Measured direction: 6 direction

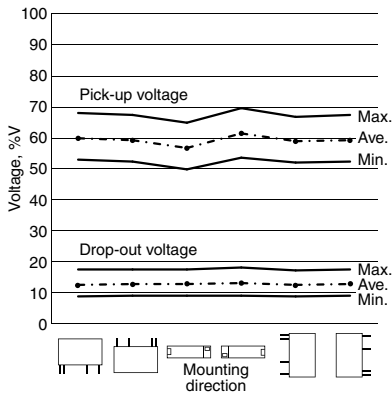

- When mounting the relays within 1 mm **.039 inch**, please notice the condition below.

- 1) Mount the relays in the same direction.

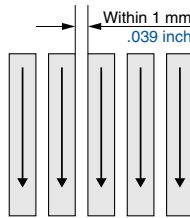

- 2) Coil terminals (Terminal No. 1 & 2) polarity should be arranged in the same direction.

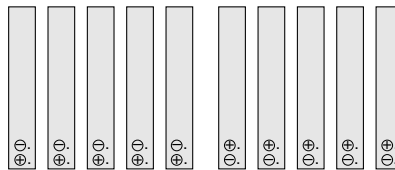

Please contact

Panasonic Corporation

Electromechanical Control Business Division

■ 1006, Oaza Kadoma, Kadoma-shi, Osaka 571-8506, Japan
industrial.panasonic.com/ac/e/

Panasonic®

Mouser Electronics

Authorized Distributor

Click to View Pricing, Inventory, Delivery & Lifecycle Information:

Panasonic:

[APAN3105](#) [APAN3118](#) [APAN3103](#) [APAN3112](#) [APAN3109](#) [APAN314H](#) [APAN3124](#) [APAN3106](#)



Компания «ЭлектроПласт» предлагает заключение долгосрочных отношений при поставках импортных электронных компонентов на взаимовыгодных условиях!

Наши преимущества:

- Оперативные поставки широкого спектра электронных компонентов отечественного и импортного производства напрямую от производителей и с крупнейших мировых складов;
- Поставка более 17-ти миллионов наименований электронных компонентов;
- Поставка сложных, дефицитных, либо снятых с производства позиций;
- Оперативные сроки поставки под заказ (от 5 рабочих дней);
- Экспресс доставка в любую точку России;
- Техническая поддержка проекта, помощь в подборе аналогов, поставка прототипов;
- Система менеджмента качества сертифицирована по Международному стандарту ISO 9001;
- Лицензия ФСБ на осуществление работ с использованием сведений, составляющих государственную тайну;
- Поставка специализированных компонентов (Xilinx, Altera, Analog Devices, Intersil, Interpoint, Microsemi, Aeroflex, Peregrine, Syfer, Eurofarad, Texas Instrument, Miteq, Cobham, E2V, MA-COM, Hittite, Mini-Circuits, General Dynamics и др.);

Помимо этого, одним из направлений компании «ЭлектроПласт» является направление «Источники питания». Мы предлагаем Вам помощь Конструкторского отдела:

- Подбор оптимального решения, техническое обоснование при выборе компонента;
- Подбор аналогов;
- Консультации по применению компонента;
- Поставка образцов и прототипов;
- Техническая поддержка проекта;
- Защита от снятия компонента с производства.



Как с нами связаться

Телефон: 8 (812) 309 58 32 (многоканальный)

Факс: 8 (812) 320-02-42

Электронная почта: org@eplast1.ru

Адрес: 198099, г. Санкт-Петербург, ул. Калинина, дом 2, корпус 4, литера А.