



LP2950*/2951

100mA Low-Dropout Voltage Regulator

General Description

The LP2950 and LP2951 are micropower voltage regulators with very low dropout voltage (typically 40mV at light loads and 380mV at 100mA), and very low quiescent current (75A typical). The quiescent current of the LP2950 /LP2951 increases only slightly in dropout, thus prolonging battery life. This feature, among others, makes the LP2950 and LP2951 ideally suited for use in battery-powered systems.

Available in a 3-pin TO-92 package, the LP2950 is pin-compatible with the older 5V regulators. Additional system functions, such as programmable output voltage and logic-controlled shutdown, are available in the 8-pin DIP and 8-pin SOIC versions of the LP2951.

Data sheets and support documentation can be found on Micrel's web site at: www.micrel.com.

Features

- High accuracy 5V, guaranteed 100mA output
- Extremely low quiescent current
- Low-dropout voltage
- Extremely tight load and line regulation
- Very low temperature coefficient
- Use as regulator or reference
- Needs only 1µF for stability

LP2951 Versions Only

- Current and thermal limiting
- Error flag warns of output dropout
- Logic-controlled electronic shutdown
- Output programmable from 1.24 to 29V

Applications

- Automotive electronics
- Voltage reference
- Avionics

Block Diagram

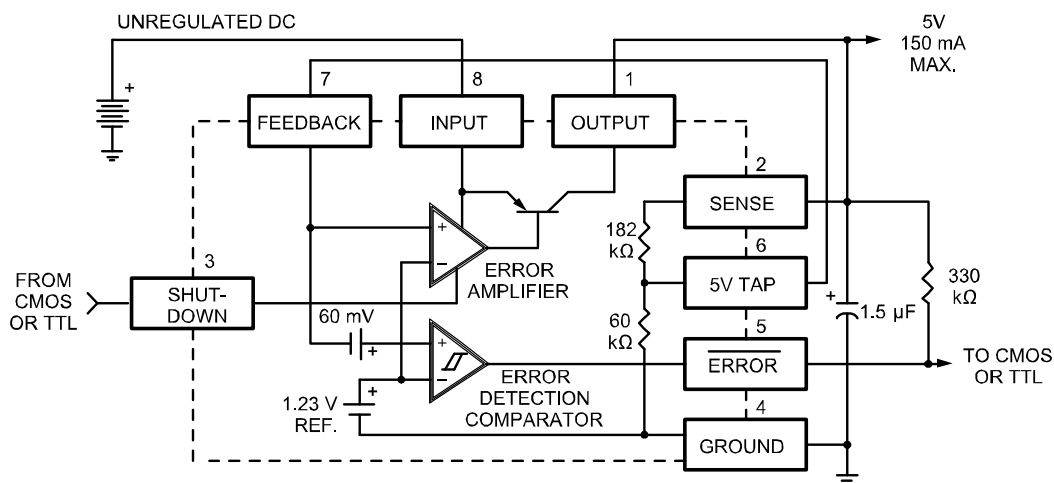

LP2950 and LP2951 Block Diagram
(Pin Numbers Refer to LP2951)

* LP2950 Discontinuance September 2007.

Additional features available with the LP2951 also include an error flag output that warns of a low output voltage, which is often due to failing batteries on the input. This may also be used as a power-on reset. A logic-compatible shutdown input is also available which enables the regulator to be switched on and off. This part may also be pin-strapped for a 5V output, or programmed from 1.24V to 29V with the use of two external resistors.

The LP2950 is available as either a -02 or -03 version. The -02 and -03 versions are guaranteed for junction

temperatures from -40°C to $+125^{\circ}\text{C}$; the -02 version has a tighter output and reference voltage specification range over temperature. The LP2951 is available as an -02 or -03 version.

The LP2950 and LP2951 have a tight initial tolerance (0.5% typical), a very low output voltage temperature coefficient which allows use as a low-power voltage reference, and extremely good load and line regulation (0.05% typical). This greatly reduces the error in the overall circuit, and is the result of careful design techniques and process control.

Ordering Information

Part Number	Voltage	Accuracy	Junction Temperature Range	Package	Lead Finish
LP2950-02BZ*	5.0V	0.5%	-40° to $+125^{\circ}\text{C}$	3-Pin TO-92 Plastic	Standard
LP2950-03BZ*	5.0V	1.0%	-40° to $+125^{\circ}\text{C}$	3-Pin TO-92 Plastic	Standard
LP2951-02BM	5.0V	0.5%	-40° to $+125^{\circ}\text{C}$	8-Pin SOIC	Standard
LP2951-03BM	5.0V	1.0%	-40° to $+125^{\circ}\text{C}$	8-Pin SOIC	Standard
LP2951-02BN	5.0V	0.5%	-40° to $+125^{\circ}\text{C}$	8-Pin Plastic DIP	Standard
LP2951-03BN**	5.0V	1.0%	-40° to $+125^{\circ}\text{C}$	8-Pin Plastic DIP	Standard
LP2951-02YM	5.0V	0.5%	-40° to $+125^{\circ}\text{C}$	8-Pin SOIC	Pb-Free
LP2951-03YM	5.0V	1.0%	-40° to $+125^{\circ}\text{C}$	8-Pin SOIC	Pb-Free
LP2951-02YN	5.0V	0.5%	-40° to $+125^{\circ}\text{C}$	8-Pin Plastic DIP	Pb-Free

Note:

* TO-92 Package discontinuance notification issued September 2007. End-of-life-buy offer thru December 31, 2007. Contact factory for additional information.

** Contact factory for Pb-Free version.

Pin Configuration

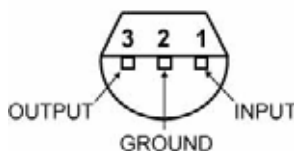

TO-92 (Z)
(Bottom View)

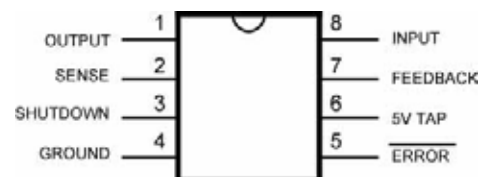

DIP (N) and SOIC (M)

See MIC2950 for a part with: 1) higher output (150mA), 2) transient protection (60V), and 3) reverse input protection to -20V .

Absolute Maximum Ratings⁽¹⁾

If Military/Aerospace specified devices are required, contact your local Micrel representative/distributor for availability and specifications.

Power Dissipation Internally Limited
 Lead Temperature (soldering, 5 sec.) 260°C
 Storage Temperature -65°C to +150°C
 Operating Junction Temperature Range⁽⁸⁾
 LP2950, LP2951 -40°C to +125°C
 Input Supply Voltage -0.3 to +30V
 Feedback Input Voltage^(9, 10) -1.5 to +30V
 Shutdown Input Voltage⁽⁹⁾ -0.3 to +30V
 Error Comparator Output Voltage⁽⁹⁾ -0.3 to +30V
 ESD Rating is to be determined

Electrical Characteristics⁽¹⁾

T_A = 25°C except as noted.

Parameter	Condition	Min	Typ	Max	Units
Output Voltage T _J = 25°C	LP295x-02 (±0.5%)	4.975	5.000	5.025	V
	LP295x-03 (±1%)	4.950	5.000	5.050	V
	LP2951-4.8 (±1%)	4.802	4.850	4.899	V
Output Voltage -25°C ≤ T _J ≤ +85°C	LP295x-02 (±0.5%)	4.950		5.050	V
	LP295x-03 (±1%)	4.925		5.075	V
	LP2951-4.8 (±1%)	4.777		4.872	V
Output Voltage Over Full Temperature Range -40°C to +125°C	LP295x-02 (±0.5%)	4.940		5.060	V
	LP295x-03 (±1%)	4.900		5.100	V
	LP2951-4.8 (±1%)	4.753		4.947	V
Output Voltage Over Load Variation	LP295x-02 (±0.5%), 100μA ≤ I _L ≤ 100mA, T _J ≤ T _{J(max)}	4.930		5.070	V
	LP295x-03 (±1%), 100μA ≤ I _L ≤ 100mA, T _J ≤ T _{J(max)}	4.880		5.120	V
	LP2951-4.8 (±1%), 100μA ≤ I _L ≤ 100mA, T _J ≤ T _{J(max)}	4.733		4.967	V
Output Voltage Temperature Coefficient	LP295x-02 (±0.5%), Note 12		20	100	ppm/°C
	LP295x-03 (±1%), Note 12		50	150	ppm/°C
	LP2951-4.8 (±1%), Note 12		50	150	ppm/°C
Line Regulation	LP295x-02 (±0.5%), Notes 14, 15		0.03	0.10 0.20	% %
	LP295x-03 (±1%), Notes 14, 15		0.04	0.20 0.40	% %
	LP2951-4.8 (±1%), Notes 14, 15		0.04	0.20 0.40	% %
Load Regulation	LP295x-02 (±0.5%), Note 14 , 100μA ≤ I _L ≤ 100mA		0.04	0.10 0.20	% %
	LP295x-03 (±1%), Note 14 , 100μA ≤ I _L ≤ 100mA		0.10	0.20 0.30	% %
	LP2951-4.8 (±1%), Note 14 , 100μA ≤ I _L ≤ 100mA		0.10	0.20 0.30	% %

Parameter	Condition	Min	Typ	Max	Units
Dropout Voltage	Note 5 , $I_L = 100\mu\text{A}$		50	80 150	mV mV
	Note 5 , $I_L = 100\text{mA}$		380	450 600	mV mV
Ground Current	$I_L = 100\mu\text{A}$		100	150 200	μA μA
	$I_L = 100\text{mA}$		8	12 14	mA mA
Dropout Current	$V_{IN} = 4.5\text{V}$, $I_L = 100\mu\text{A}$		180	250 310	μA μA
Current Limit	$V_{OUT} = 0\text{V}$		160	220 220	mA mA
Thermal Regulation	Note 13		0.05	0.20	%/W
Output Noise	10Hz to 100kHz, $C_L = 1\mu\text{F}$		430		μV_{RMS}
	10Hz to 100kHz, $C_L = 200\mu\text{F}$		160		μV_{RMS}
	10Hz to 100kHz, $C_L = 3.3\mu\text{F}$, 0.01 μF bypass Feedback to Output		100		μV_{RMS}
Reference Voltage	LP295x-02 ($\pm 0.5\%$)	1.220 1.200	1.235	1.250 1.260	V V
	LP295x-03 ($\pm 1\%$)	1.210 1.200	1.235	1.260 1.270	V V
	LP2951-4.8 ($\pm 1\%$)	1.210 1.200	1.235	1.260 1.270	V V
Reference Voltage	LP295x-02 ($\pm 0.5\%$), Note 7	1.190		1.270	V
	LP295x-03 ($\pm 1\%$), Note 7	1.185		1.285	V
	LP2951-4.8 ($\pm 1\%$), Note 7	1.185		1.285	V
Feedback Bias Current			20	40 60	nA nA
Reference Voltage	LP295x-02 ($\pm 0.5\%$), Note 12		20		ppm/ $^{\circ}\text{C}$
	LP295x-03 ($\pm 1\%$), Note 12		50		ppm/ $^{\circ}\text{C}$
	LP2951-4.8 ($\pm 1\%$), Note 12		50		ppm/ $^{\circ}\text{C}$
Feedback Bias Current Temperature Coefficient			0.1		nA/ $^{\circ}\text{C}$
Output Leakage Current	$V_{OH} = 30\text{V}$		0.01	1.00 2.00	μA μA
Output Low Voltage (Flag)	$V_{IN} = 4.5\text{V}$, $I_{OL} = 200\mu\text{A}$		150	250 400	mV mV
Upper Threshold Voltage	Note 6	40 25	60		mV mV
Lower Threshold Voltage	Note 6		75	95 140	mV mV
Hysteresis	Note 6		15		mV

Parameter	Condition	Min	Typ	Max	Units
Input Logic Voltage	LP295x-02 ($\pm 0.5\%$) Low High	2.0	1.3	0.7	V
					V
					V
	LP295x-03 ($\pm 1\%$) Low High	2.0	1.3	0.7	V
					V
					V
LP2951-4.8 ($\pm 1\%$) Low High	2.0	1.3	0.7	V	
				V	
				V	
Shutdown Input Current	$V_{\text{SHUTDOWN}} = 2.4\text{V}$		30	50 100	μA μA
	$V_{\text{SHUTDOWN}} = 30\text{V}$		450	600 700	μA μA
Regulator Output Current in Shutdown	Note 11		3	10 20	μA μA

Notes:

- Boldface limits apply at temperature extremes.
- Unless otherwise specified all limits guaranteed for $T_J = 25^\circ\text{C}$, $V_{\text{IN}} = 6\text{V}$, $I_L = 100\mu\text{A}$ and $C_L = 1\mu\text{F}$. Additional conditions for the 8-pin versions are Feedback tied to 5V Tap and Output tied to Output Sense ($V_{\text{OUT}} = 5\text{V}$) and $V_{\text{SHUTDOWN}} \leq 0.8\text{V}$.
- Guaranteed and 100% production tested.
- Guaranteed but not 100% production tested. These limits are not used to calculate outgoing AQL levels.
- Dropout voltage is defined as the input to output differential at which the output voltage drops 100mV below its nominal value measured at 1V differential. At very low values of programmed output voltage, the minimum input supply voltage of 2V (2.3V over temperature) must be taken into account.
- Comparator thresholds are expressed in terms of a voltage differential at the Feedback terminal below the nominal reference voltage measured at 6V input. To express these thresholds in terms of output voltage change, multiply by the error amplifier gain $= V_{\text{OUT}}/V_{\text{REF}} = (R1 + R2)/R2$. For example, at a programmed output voltage of 5V, the Error output is guaranteed to go low when the output drops by $95\text{mV} \times 5\text{V}/1.235\text{V} = 384\text{mV}$. Thresholds remain constant as a percent of V_{OUT} as V_{OUT} is varied, with the dropout warning occurring at typically 5% below nominal, 7.5% guaranteed.
- $V_{\text{REF}} \leq V_{\text{OUT}} \leq (V_{\text{IN}} - 1\text{V})$, $2.3\text{V} \leq V_{\text{IN}} \leq 30\text{V}$, $100\mu\text{A} < I_L \leq 100\text{mA}$, $T_J \leq T_{\text{JMAX}}$.
- The junction-to-ambient thermal resistance of the TO-92 package is 180°C/W with 0.4" leads and 160°C/W with 0.25" leads to a PC board. The thermal resistance of the 8-pin DIP package is 105°C/W junction-to-ambient when soldered directly to a PC board. Junction-to-ambient thermal resistance for the SOIC (M) package is 160°C/W .
- May exceed input supply voltage.
- When used in dual-supply systems where the output terminal sees loads returned to a negative supply, the output voltage should be diode-clamped to ground.
- $V_{\text{SHUTDOWN}} \geq 2\text{V}$, $V_{\text{IN}} \leq 30\text{V}$, $V_{\text{OUT}} = 0$, with Feedback pin tied to 5V Tap.
- Output or reference voltage temperature coefficient is defined as the worst case voltage change divided by the total temperature range.
- Thermal regulation is defined as the change in output voltage at a time T after a change in power dissipation is applied, excluding load or line regulation effects. Specifications are for a 50mA load pulse at $V_{\text{IN}} = 30\text{V}$ (1.25W pulse) for $t = 10\text{ms}$.
- Regulation is measured at constant junction temperature, using pulse testing with a low duty cycle. Changes in output voltage due to heating effects are covered in the specification for thermal regulation.
- Line regulation for the LP2951 is tested at 150°C for $I_L = 1\text{mA}$. For $I_L = 100\mu\text{A}$ and $T_J = 125^\circ\text{C}$, line regulation is guaranteed by design to 0.2%. See Typical Performance Characteristics for line regulation versus temperature and load current.

Typical Characteristics

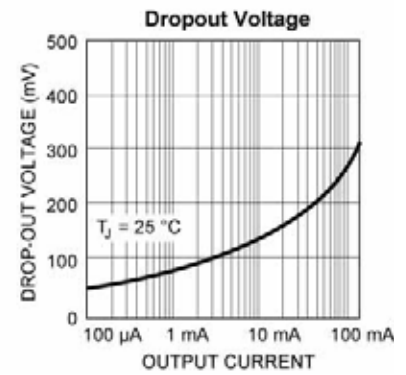
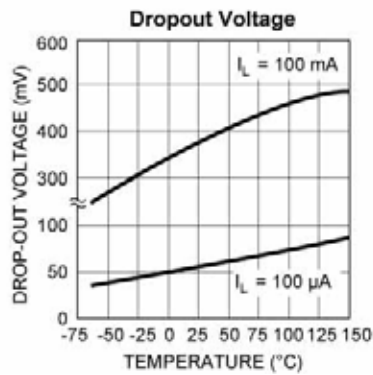
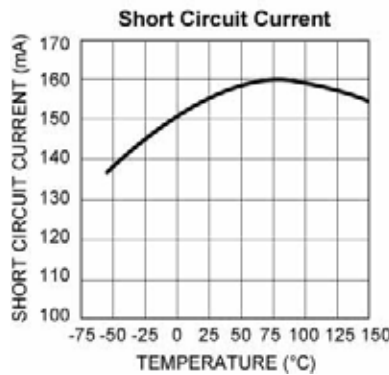
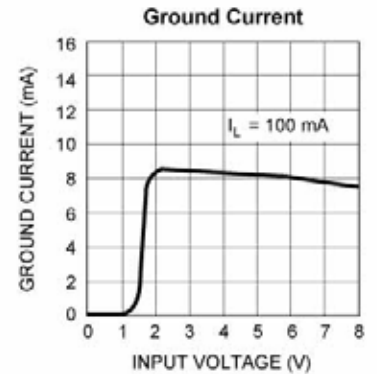
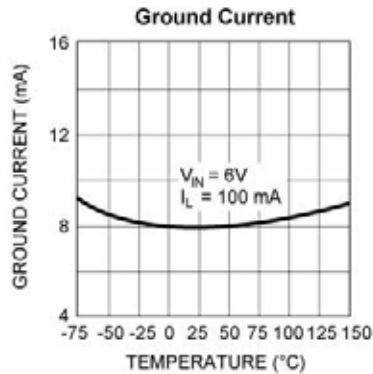
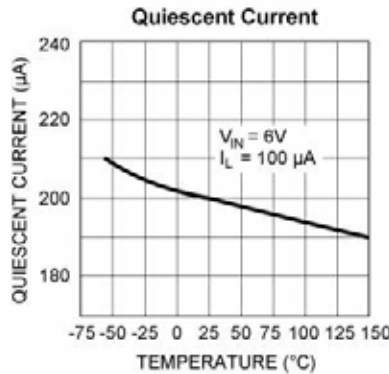
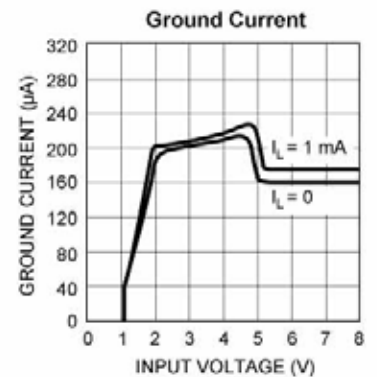
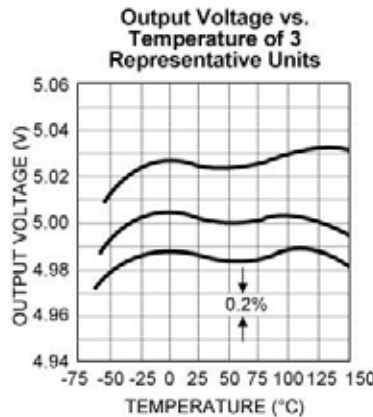
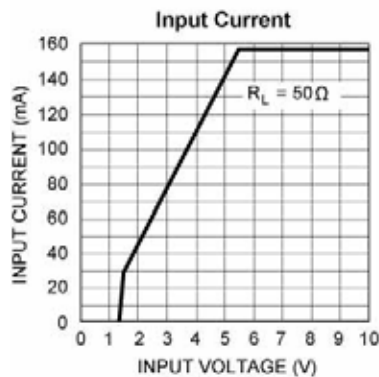
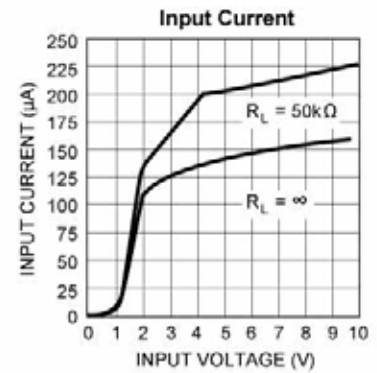
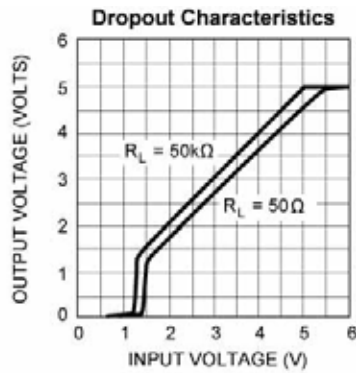
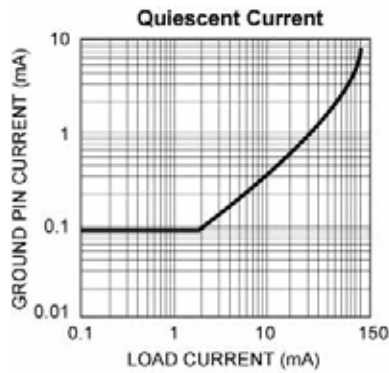

Typical Characteristics (continued)

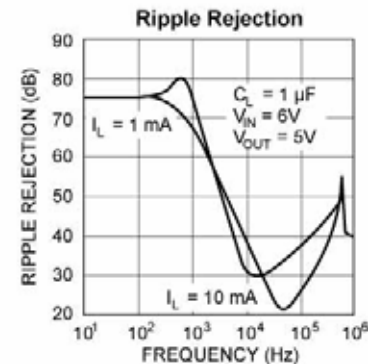
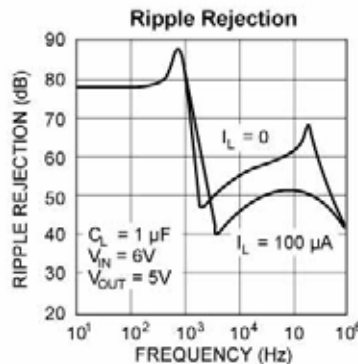
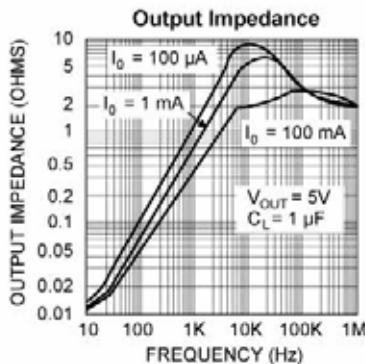
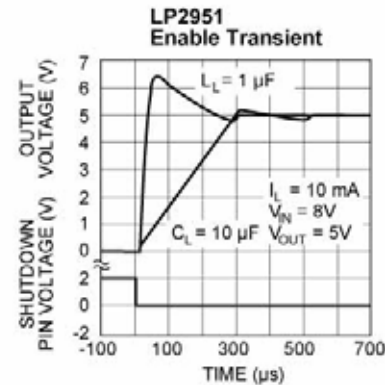
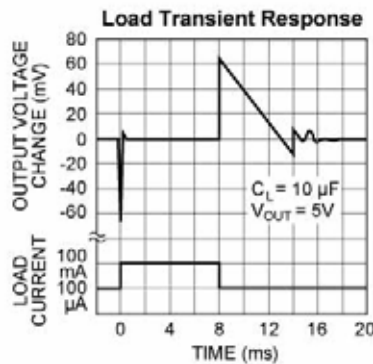
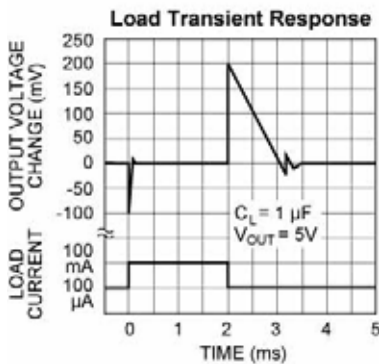
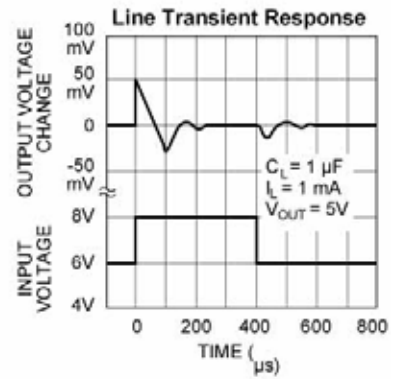
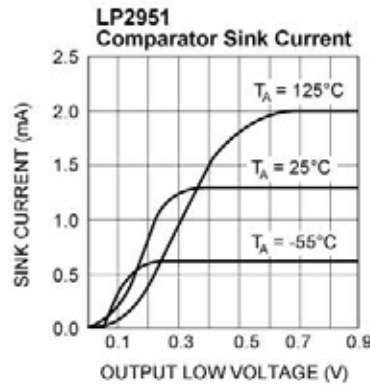
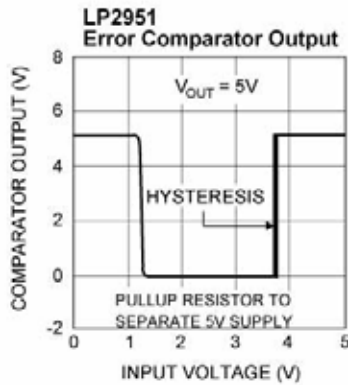
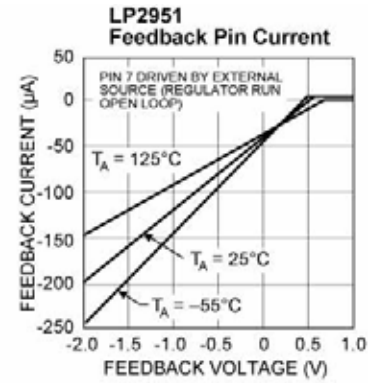
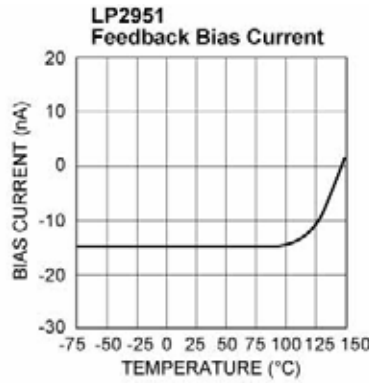
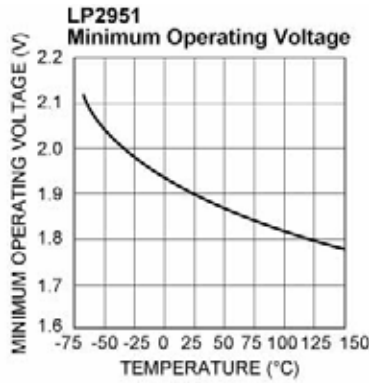

Typical Characteristics (continued)

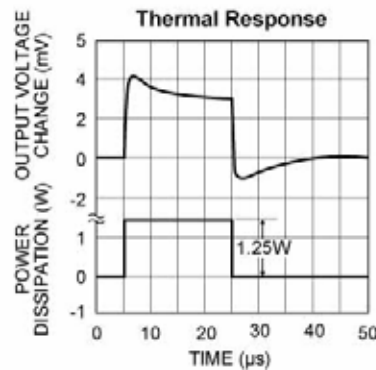
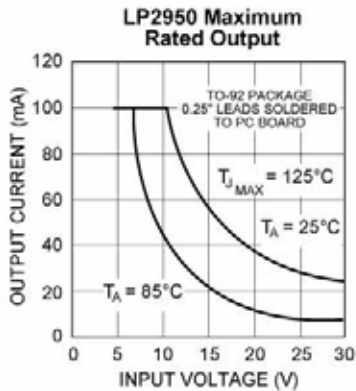
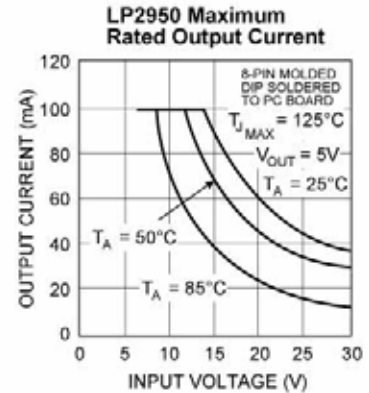
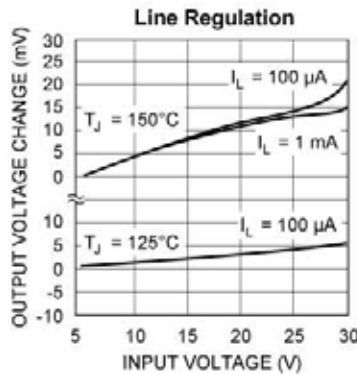
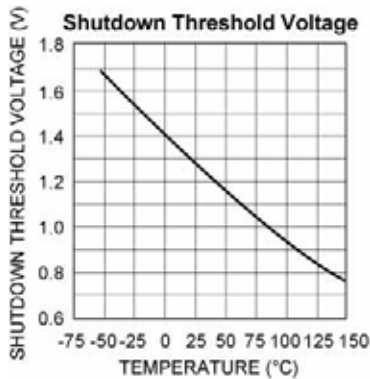
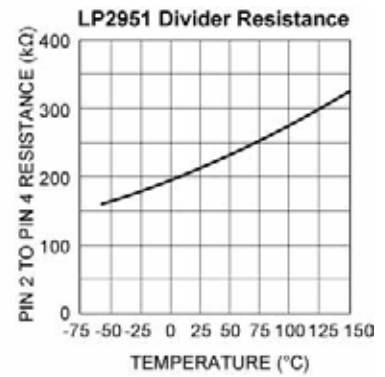
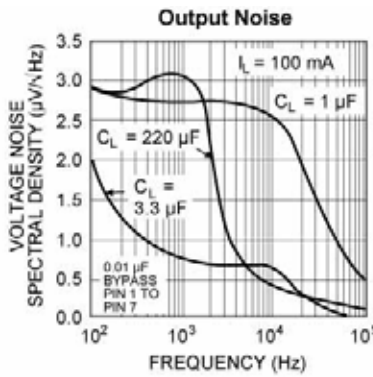
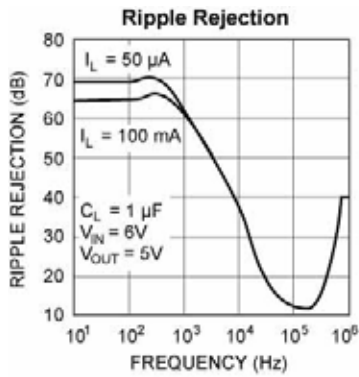

Application Information

External Capacitors

A 1.0 μ F (or greater) capacitor is required between the LP2950/LP2951 output and ground to prevent oscillations due to instability. Most types of tantalum or aluminum electrolytics will be adequate; film types will work, but are costly and therefore not recommended. Many aluminum electrolytics have electrolytes that freeze at about -30°C , so solid tantalum capacitors are recommended for operation below -25°C . The important parameters of the capacitor are an effective series resistance of about 5 or less and a resonant frequency above 500kHz. The value of this capacitor may be increased without limit.

At lower values of output current, less output capacitance is required for output stability. The capacitor can be reduced to 0.33 μ F for current below 10mA or 0.1 μ F for currents below 1mA. Using the 8-pin versions at voltages below 5V runs the error amplifier at lower gains so that more output capacitance is needed. For the worst-case situation of a 100mA load at 1.23V output (Output shorted to Feedback) a 3.3 μ F (or greater) capacitor should be used.

The LP2950 will remain stable and in regulation with no load in addition to the internal voltage divider, unlike many other voltage regulators. This is especially important in CMOS RAM keep-alive applications. When setting the output voltage of the LP2951 version with external resistors, a minimum load of 1 μ A is recommended.

A 0.1 μ F capacitor should be placed from the LP2950/LP2951 input to ground if there is more than 10 inches of wire between the input and the AC filter capacitor or if a battery is used as the input.

Stray capacitance to the LP2951 Feedback terminal (pin 7) can cause instability. This may especially be a problem when using high value external resistors to set the output voltage. Adding a 100pF capacitor between Output and Feedback and increasing the output capacitor to at least 3.3 μ F will remedy this.

Error Detection Comparator Output

A logic low output will be produced by the comparator whenever the LP2951 output falls out of regulation by more than approximately 5%. This figure is the comparator's built-in offset of about 60mV divided by the 1.235V reference voltage. (Refer to the block diagram on Page 1). This trip level remains "5% below normal" regardless of the programmed output voltage of the LP2951. For example, the error flag trip level is typically 4.75V for a 5V output or 11.4V for a 12V output. The out of regulation condition may be due either to low input voltage, current limiting, or thermal limiting.

Figure 1 is a timing diagram depicting the /ERROR signal and the regulated output voltage as the LP2951 input is ramped up and down. The /ERROR signal becomes valid (low) at about 1.3V input. It goes high at about 5V input (the input voltage at which $V_{\text{OUT}} = 4.75\text{V}$). Since the LP2951's dropout voltage is load-dependent (see curve in Typical Performance Characteristics), the input voltage trip point (about 5V) will vary with the load current. The output voltage trip point (approximately 4.75V) does not vary with load.

The error comparator has an open-collector output which requires an external pull-up resistor. Depending on system requirements, this resistor may be returned to the 5V output or some other supply voltage. In determining a value for this resistor, note that while the output is rated to sink 400 μ A, this sink current adds to battery drain in a low battery condition. Suggested values range from 100k to 1M Ω . The resistor is not required if this output is unused.

Programming the Output Voltage (LP2951)

The LP2951 may be pin-strapped for 5V using its internal voltage divider by tying Pin 1 (output) to Pin 2 (SENSE) and Pin 7 (FEEDBACK) to Pin 6 (5V TAP). Alternatively, it may be programmed for any output voltage between its 1.235V reference and its 30V maximum rating. An external pair of resistors is required, as shown in Figure 2.

The complete equation for the output voltage is:

$$V_{\text{OUT}} = V_{\text{REF}} \times \left\{ 1 + \frac{R_1}{R_2} \right\} + I_{\text{FB}} R_2$$

where V_{REF} is the nominal 1.235 reference voltage and I_{FB} is the feedback pin bias current, nominally 20nA. The minimum recommended load current of 1 μ A forces an upper limit of 1.2M Ω on the value of R_2 , if the regulator must work with no load (a condition often found in CMOS in standby), I_{FB} will produce a 2% typical error in V_{OUT} which may be eliminated at room temperature by trimming R_1 . For better accuracy, choosing $R_2 = 100\text{k}\Omega$ reduces this error to 0.17% while increasing the resistor program current to 12 μ A. Since the LP2951 typically draws 60 μ A at no load with Pin 2 open-circuited, this is a small price to pay.

Reducing Output Noise

In reference applications it may be advantageous to reduce the AC noise present at the output. One method is to reduce the regulator bandwidth by increasing the size of the output capacitor. This is the only method by which noise can be reduced on the 3-pin LP2950 and is relatively inefficient, as increasing the capacitor from 1 μ F to 220 μ F only decreases the noise from 430 μ V to 160 μ Vrms for a 100kHz bandwidth at 5V output.

Noise can be reduced fourfold by a bypass capacitor across R_1 , since it reduces the high frequency gain from 4 to unity. Pick:

$$C_{\text{BYPASS}} \cong \frac{1}{2\pi R_1 \bullet 200\text{Hz}}$$

or about $0.01\mu\text{F}$. When doing this, the output capacitor must be increased to $3.3\mu\text{F}$ to maintain stability. These changes reduce the output noise from $430\mu\text{V}$ to $100\mu\text{Vrms}$ for a 100kHz bandwidth at 5V output. With the bypass capacitor added, noise no longer scales with output voltage so that improvements are more dramatic at higher output voltages.

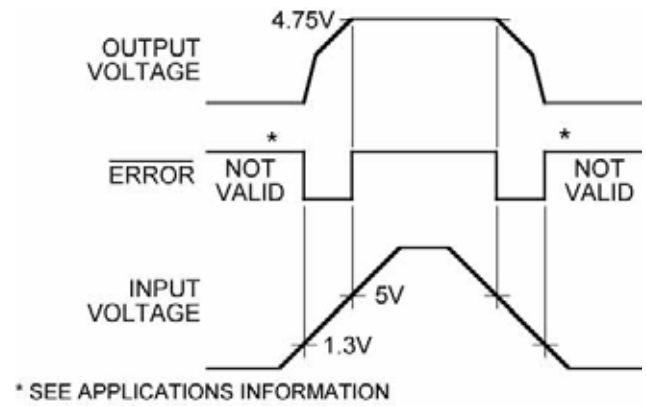

Figure 1. ERROR Output Timing

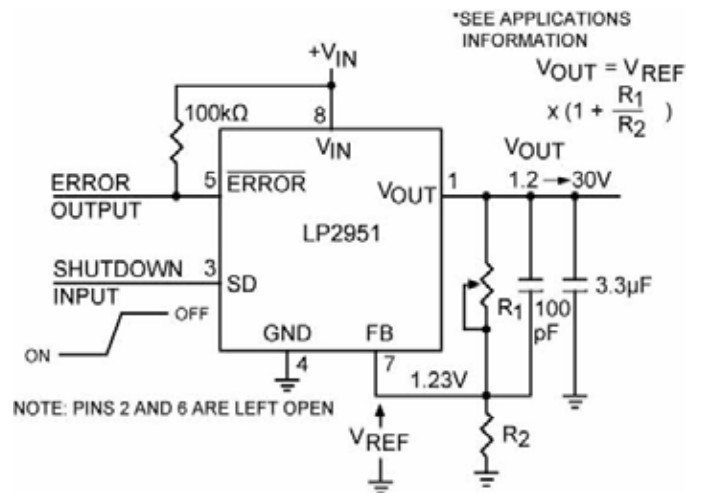
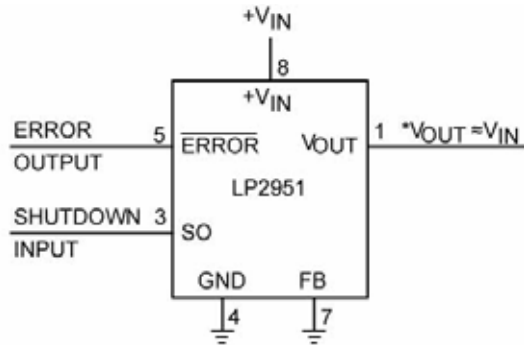

Figure 2. Adjustable Regulator

Typical Applications



*MINIMUM INPUT-OUTPUT VOLTAGE RANGES FROM 40mV TO 400mV, DEPENDING ON LOAD CURRENT. CURRENT LIMIT IS TYPICALLY 160mA.

Wide Input Voltage Range Current Limiter

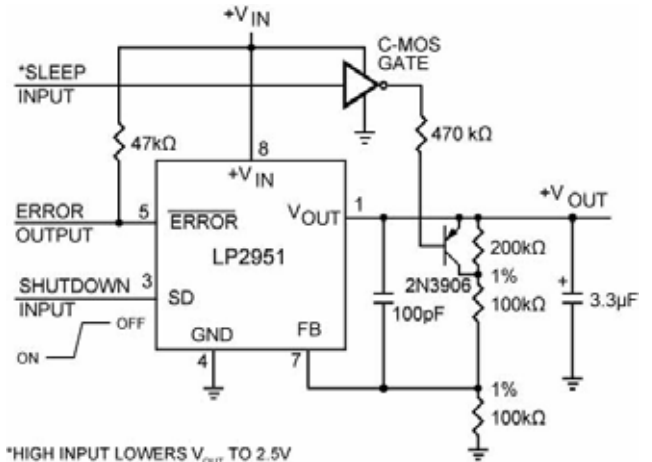

*HIGH INPUT LOWERS V_{OUT} TO 2.5V

5V Regulator with 2.5V Sleep Function

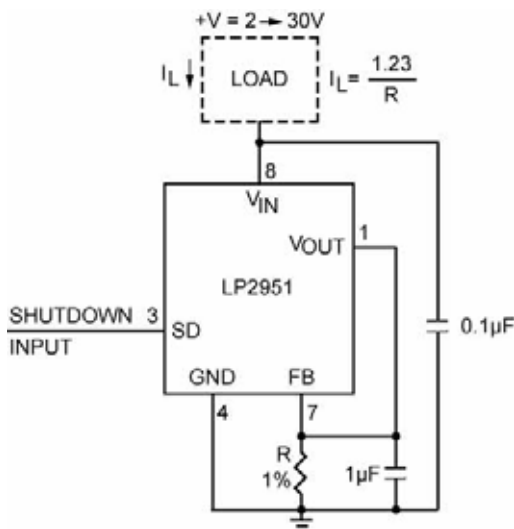

Low Drift Current Source

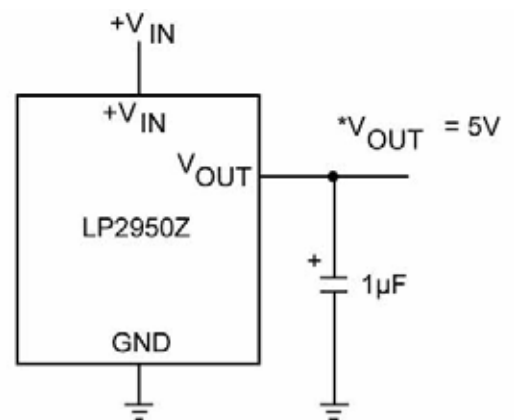

*MINIMUM INPUT-OUTPUT VOLTAGE RANGES FROM 40mV TO 400mV, DEPENDING ON LOAD CURRENT.

5V Current Limiter

Typical Applications

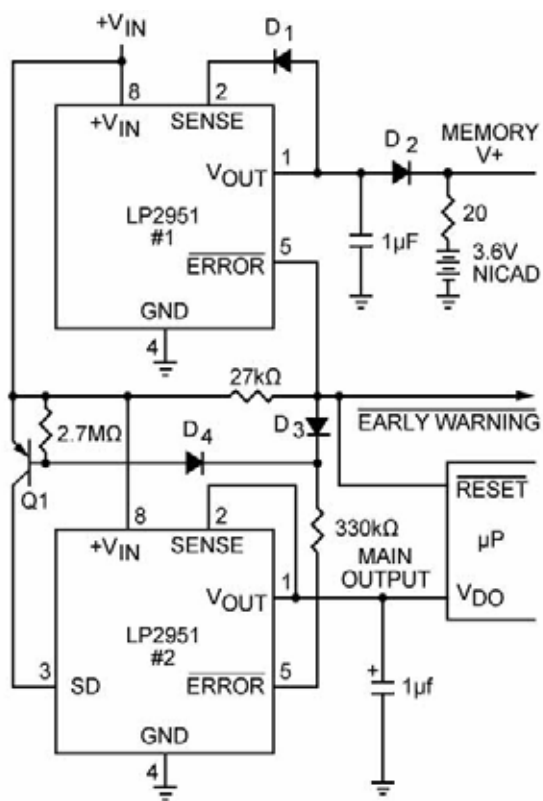

- EARLY WARNING FLAG ON LOW INPUT VOLTAGE
- MAIN OUTPUT LATCHES OFF AT LOWER INPUT VOLTAGES
- BATTERY BACKUP ON AUXILIARY OUTPUT

OPERATION: REG. #1'S V_{OUT} IS PROGRAMMED ONE DIODE DROP ABOVE 5 V. ITS ERROR FLAG BECOMES ACTIVE WHEN $V_{IN} \leq 5.7$ V. WHEN V_{IN} DROPS BELOW 5.3 V, THE ERROR FLAG OF REG. #2 BECOMES ACTIVE AND VIA Q1 LATCHES THE MAIN OUTPUT OFF. WHEN V_{IN} AGAIN EXCEEDS 5.7 V REG. #1 IS BACK IN REGULATION AND THE EARLY WARNING SIGNAL RISES, UNLATCHING REG. #2 VIA D3.

Regulator with Early Warning and Auxiliary Output

Typical Applications

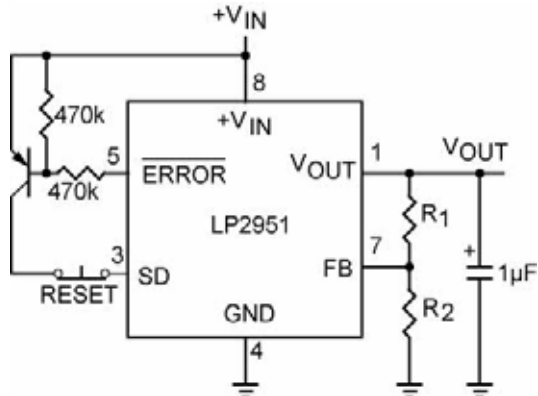

Latch Off When Error Flag Occurs

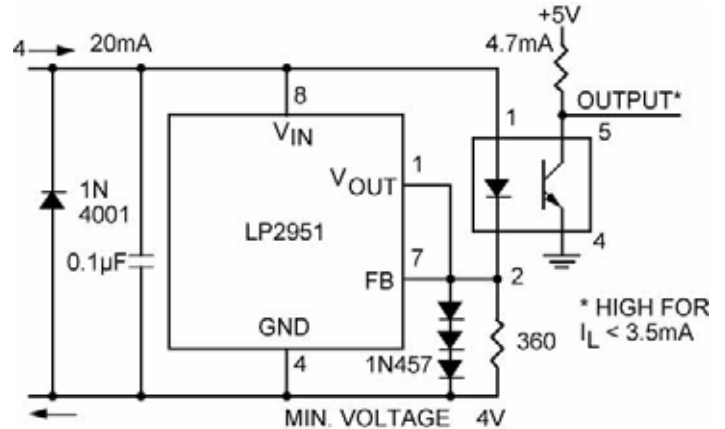

Open Circuit Detector for 4mA to 20mA Current Loop

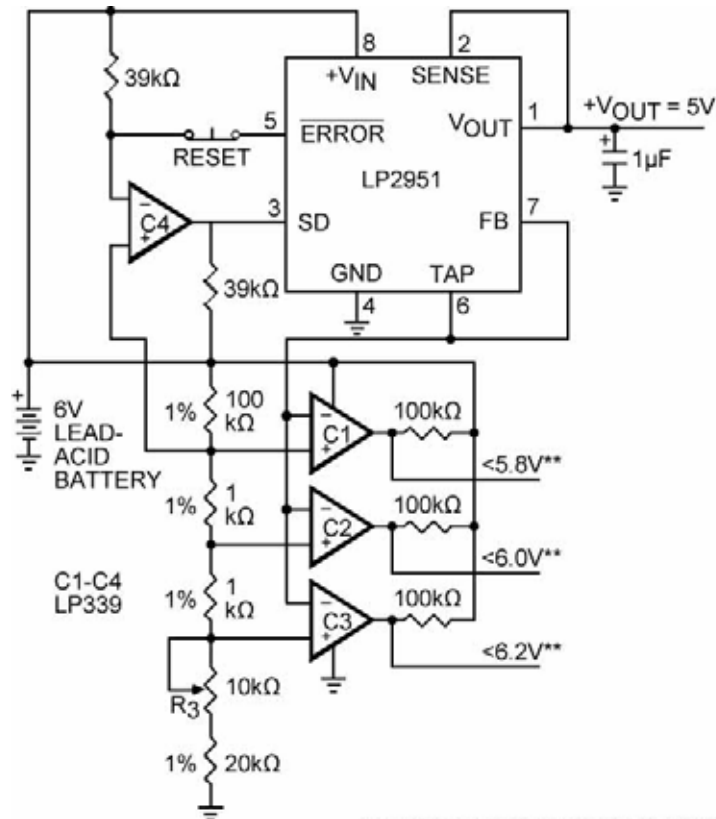

C1 TO C4 ARE COMPARATORS (LP339 OR EQUIVALENT)

*OPTIONAL LATCH OFF WHEN DROP OUT OCCURS. ADJUST R3 FOR C2 SWITCHING WHEN V_{IN} IS 6.0V

**OUTPUTS GO LOW WHEN V_{IN} DROPS BELOW DESIGNATED THRESHOLDS.

Regulator with State-of-Charge Indicator

Typical Applications

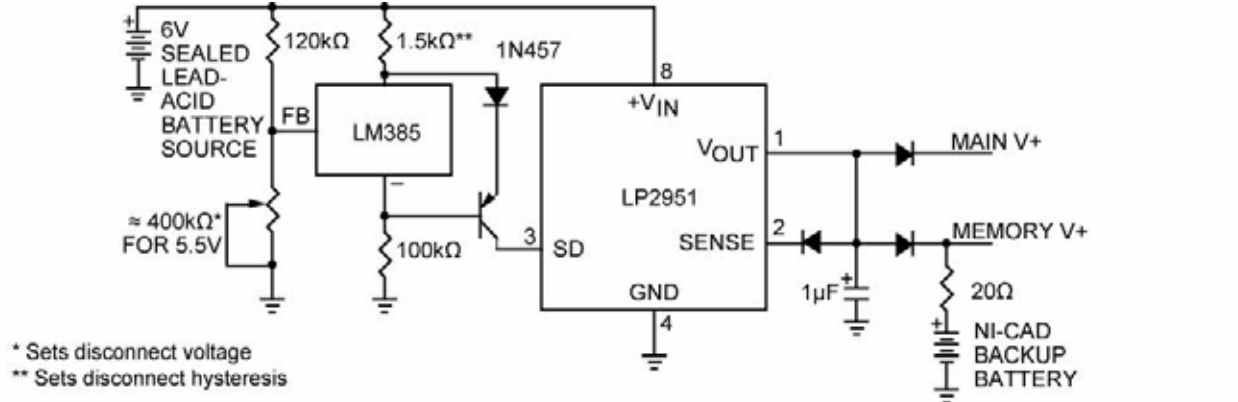

For values shown, Regulator shuts down when $V_{IN} < 5.5\text{ V}$ and turns on again at 6.0 V . Current drain in disconnected mode is $150\mu\text{A}$.

Low Battery Disconnect

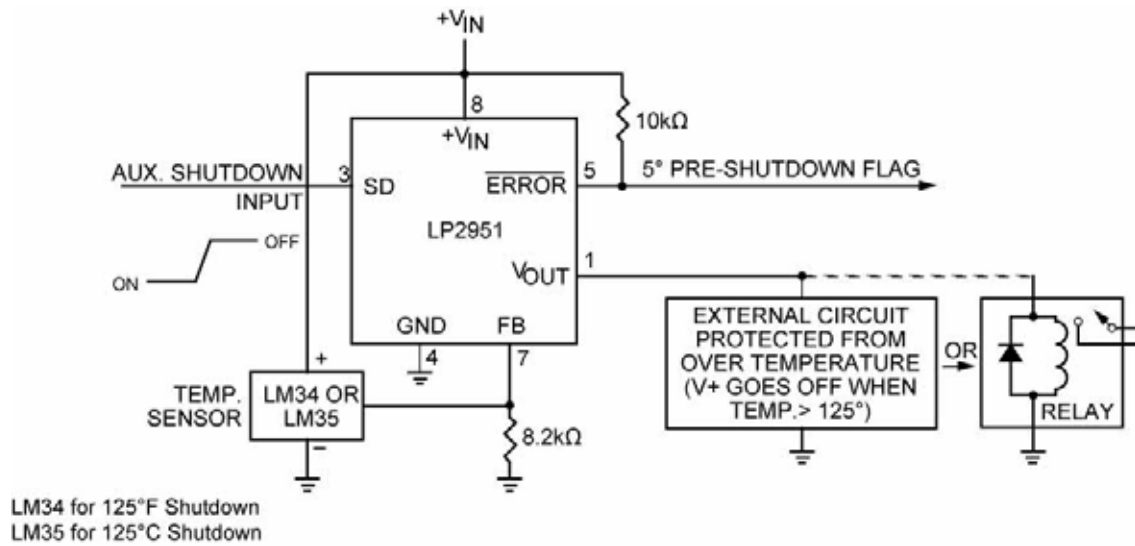

System Over Temperature Protection Circuit

Schematic Diagram

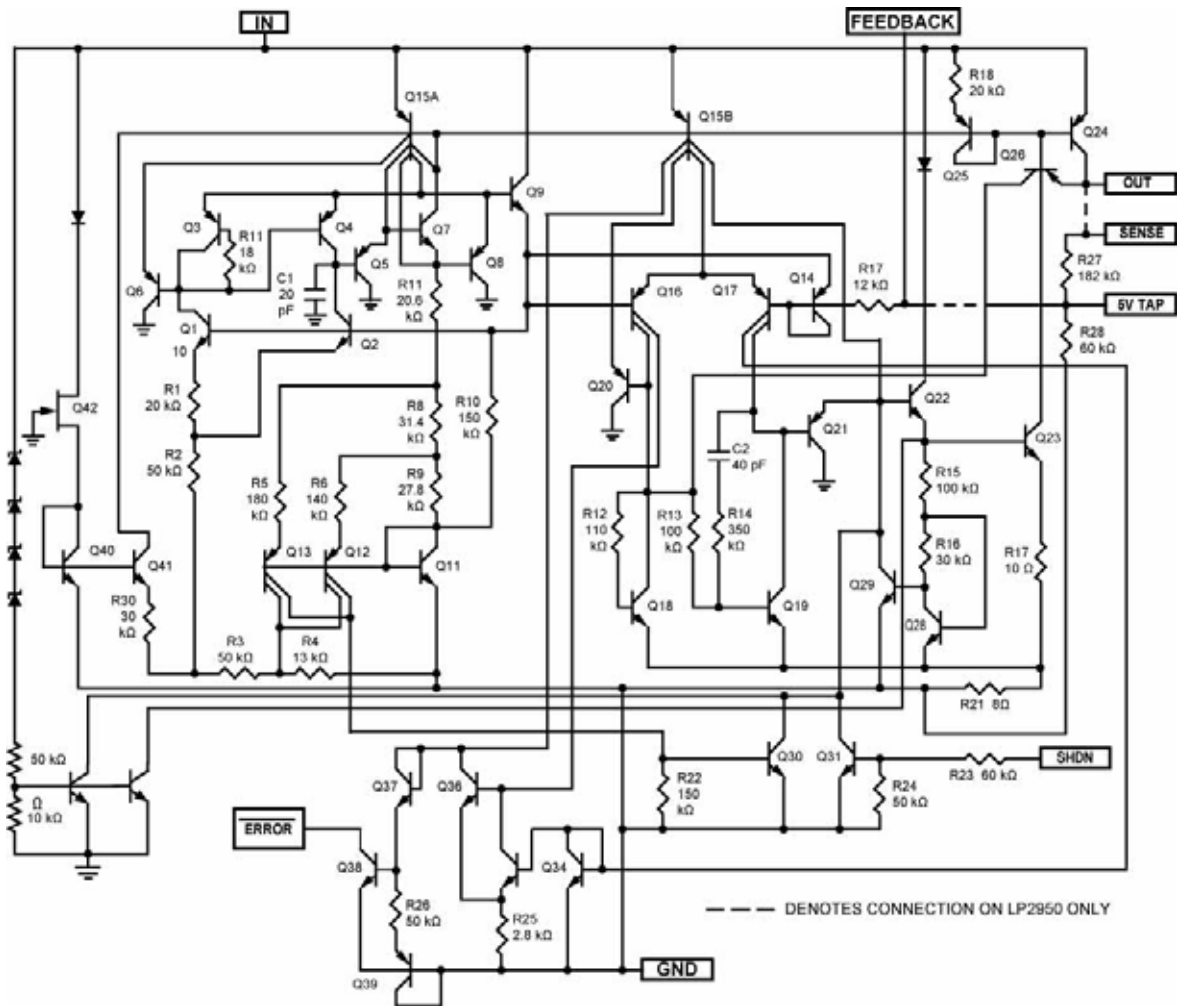

Package Information

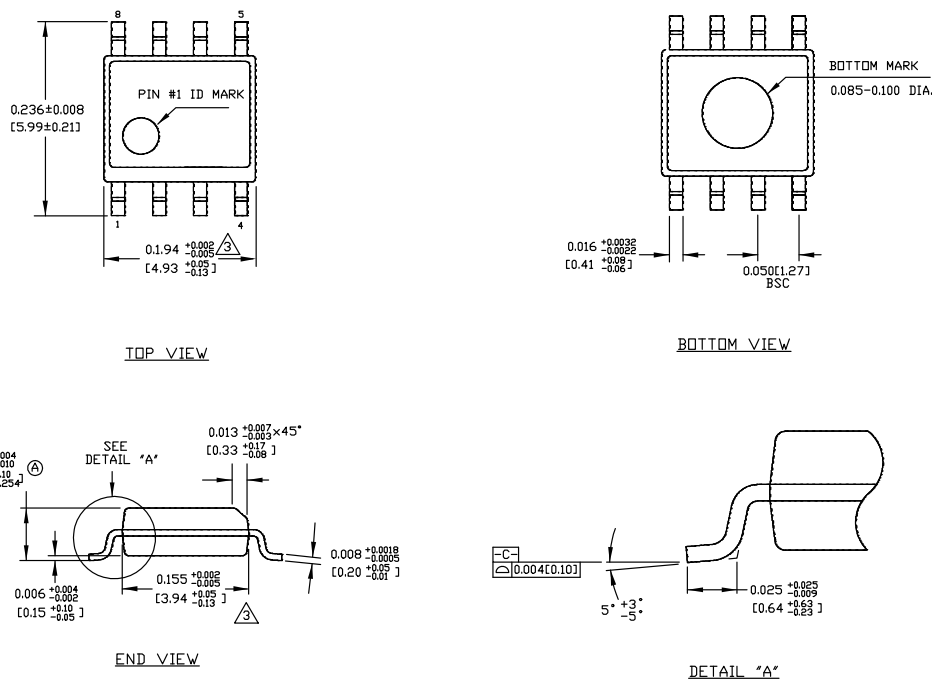

- NOTES:**
1. DIMENSIONS ARE IN INCHES(MM).
 2. CONTROLLING DIMENSION: INCHES.
- △ DIMENSION DOES NOT INCLUDE MOLD FLASH OR PROTRUSIONS, EITHER OF WHICH SHALL NOT EXCEED 0.010(0.25) PER SIDE.

8-Pin SOIC (M)

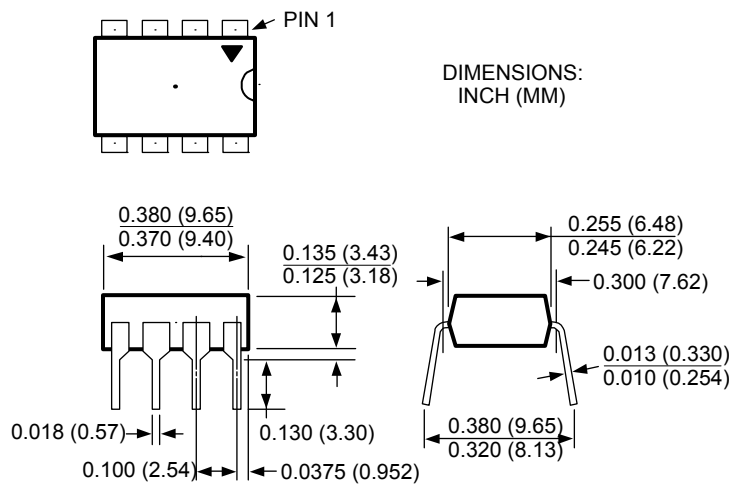

8-Pin Plastic DIP (N)

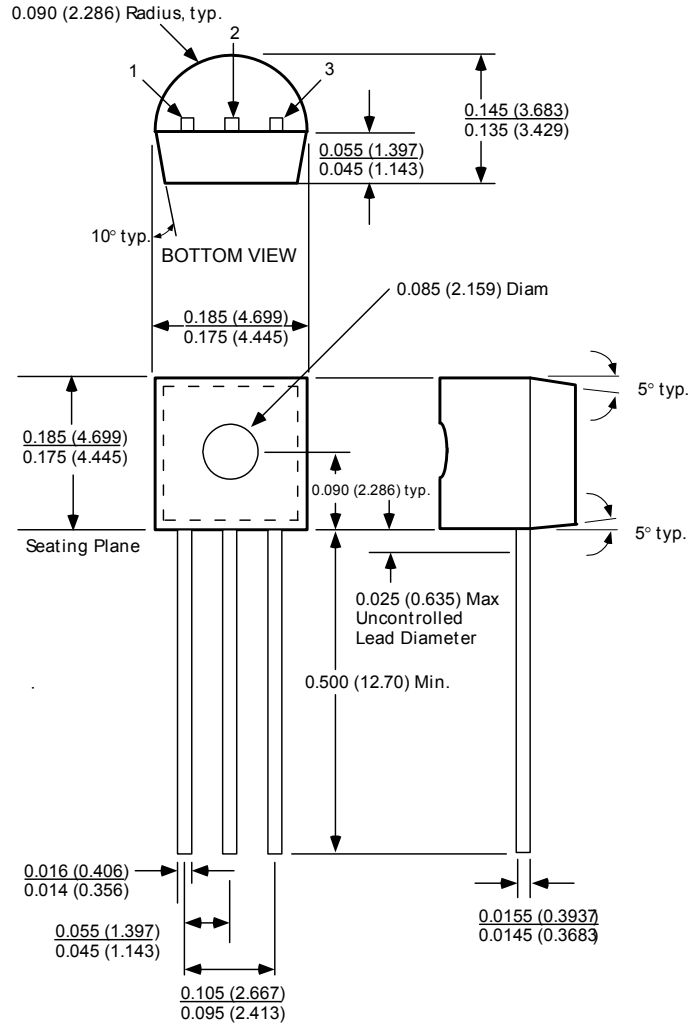

TO-92 (Z)

MICREL, INC. 2180 FORTUNE DRIVE SAN JOSE, CA 95131 USA
 TEL +1 (408) 944-0800 FAX +1 (408) 474-1000 WEB <http://www.micrel.com>

The information furnished by Micrel in this data sheet is believed to be accurate and reliable. However, no responsibility is assumed by Micrel for its use. Micrel reserves the right to change circuitry and specifications at any time without notification to the customer.

Micrel Products are not designed or authorized for use as components in life support appliances, devices or systems where malfunction of a product can reasonably be expected to result in personal injury. Life support devices or systems are devices or systems that (a) are intended for surgical implant into the body or (b) support or sustain life, and whose failure to perform can be reasonably expected to result in a significant injury to the user. A Purchaser's use or sale of Micrel Products for use in life support appliances, devices or systems is a Purchaser's own risk and Purchaser agrees to fully indemnify Micrel for any damages resulting from such use or sale.

© 1999 Micrel, Incorporated.



Компания «ЭлектроПласт» предлагает заключение долгосрочных отношений при поставках импортных электронных компонентов на взаимовыгодных условиях!

Наши преимущества:

- Оперативные поставки широкого спектра электронных компонентов отечественного и импортного производства напрямую от производителей и с крупнейших мировых складов;
- Поставка более 17-ти миллионов наименований электронных компонентов;
- Поставка сложных, дефицитных, либо снятых с производства позиций;
- Оперативные сроки поставки под заказ (от 5 рабочих дней);
- Экспресс доставка в любую точку России;
- Техническая поддержка проекта, помощь в подборе аналогов, поставка прототипов;
- Система менеджмента качества сертифицирована по Международному стандарту ISO 9001;
- Лицензия ФСБ на осуществление работ с использованием сведений, составляющих государственную тайну;
- Поставка специализированных компонентов (Xilinx, Altera, Analog Devices, Intersil, Interpoint, Microsemi, Aeroflex, Peregrine, Syfer, Eurofarad, Texas Instrument, Miteq, Cobham, E2V, MA-COM, Hittite, Mini-Circuits, General Dynamics и др.);

Помимо этого, одним из направлений компании «ЭлектроПласт» является направление «Источники питания». Мы предлагаем Вам помощь Конструкторского отдела:

- Подбор оптимального решения, техническое обоснование при выборе компонента;
- Подбор аналогов;
- Консультации по применению компонента;
- Поставка образцов и прототипов;
- Техническая поддержка проекта;
- Защита от снятия компонента с производства.

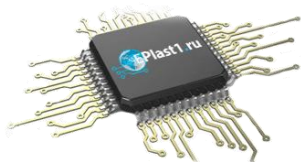

Как с нами связаться

Телефон: 8 (812) 309 58 32 (многоканальный)

Факс: 8 (812) 320-02-42

Электронная почта: org@eplast1.ru

Адрес: 198099, г. Санкт-Петербург, ул. Калинина, дом 2, корпус 4, литера А.