



Features

- Low capacitance
- Performance stability over life
- High insulation resistance
-  UL pending
- RoHS compliant*

Applications

- DC power supply protection (48 V)

2033 Series Gas Discharge Tube Surge Protector

The Bourns® Model 2033 Series is a 2-electrode 5-stack GDT surge arrester device designed for use with DC power supplies. The series is high current rated with low capacitance and allows for reset of the arrester without use of external components.

Characteristics

Test Methods per ITU-T (CCITT) K.12 and IEEE C62.31

Characteristic	Model No.	
	2033-80	2033-140
DC Sparkover $\pm 30\%$ @ 100 V/s	800 V	1400 V
Impulse Sparkover 1.2/50 μ s, 6 kV	< 2000 V	< 2300 V
Impulse Sparkover 1.2/50 μ s, 6 kV See Figure 1, C1-C4 100 pF	< 900 V	< 950 V

Insulation Resistance (IR)	100 VDC	> 10 G Ω
DC Operating Voltage (1)		60 V $\pm 20\%$
Glow Voltage	10 mA	~ 500 V
Arc Voltage	1 A	~ 100 V
Glow-Arc Transition Current		< 1 A
Capacitance	1 MHz	< 1 pF
Impulse Discharge Current	20 kA, 8/20 μ s	10 operations
	100 A, 8/20 μ s	300 operations
	4 kA, 10/350 μ s	± 5 operations
Operating & Storage Temperature		-40 °C to +125 °C
Climatic Category (IEC 60068-1)		40 / 125 / 21
Moisture Sensitivity Level		1
ESD Classification (HBM)		6

Notes:



(1) DC current source 30 A max.

- At delivery AQL 0.65 Level II, DIN ISO 2859.
- Bourns recommends reflowing surface mount devices per IPC/JEDEC J-STD-020 rev. D

How to Order

	2033 - xx - G5 - xx LF
Model Number Designator	
Voltage (Divided by 10)	
80 = 800 V	
140 = 1400 V	
Number of Gas Chambers	
G5 = Five Chambers	
Packaging	
Blank = Bulk	
T1 = Tape and Reel	
RoHS Compliancy	
LF = RoHS Compliant Product	

Typical Part Marking

2033-80-G5-LF	 80 2033
2033-140-G5-LF	 140 2033

BOURNS®

Asia-Pacific: Tel: +886-2 2562-4117 • Email: asiacus@bourns.com

EMEA: Tel: +36 88 520 390 • Email: eurocus@bourns.com

The Americas: Tel: +1-951 781-5500 • Email: americus@bourns.com

www.bourns.com

*RoHS Directive 2015/863, Mar 31, 2015 and Annex.

Specifications are subject to change without notice.

The device characteristics and parameters in this data sheet can and do vary in different applications and actual device performance may vary over time.

Users should verify actual device performance in their specific applications.

2033 Series Gas Discharge Tube Surge Protector

BOURNS®

Optimizing Model 2033 Series Stacked GDT Turn-on Performance

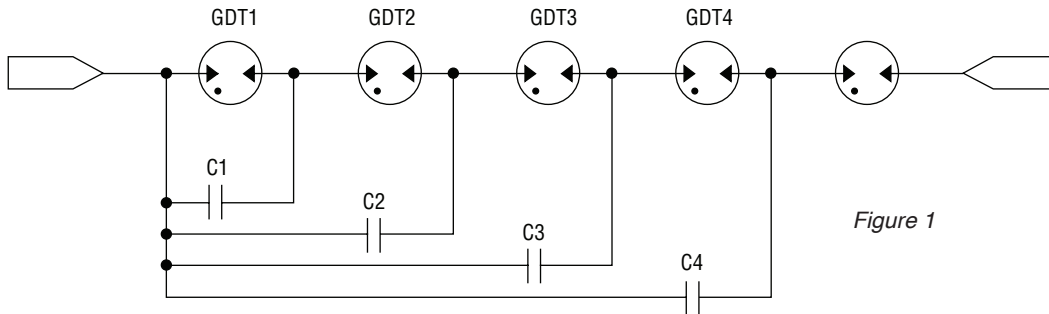

Figure 1

Application

In high current 48 Vdc supply applications, multiple GDTs are required to be connected in series so that the sum of the arc voltages exceed the dc supply voltage. The combined arc voltages of the stacked GDT (typically $12\text{ V} \times 5 = 60\text{ V}$) exceed the 48 Vdc supply which is then not capable of providing enough current to maintain the GDT in an on-state of operation. A stacked GDT design allows for proper reset of the GDT after a transient event.

The downside of a stacked design is that the summation of the individual GDT chamber sparkover voltages results in a device with a high impulse sparkover voltage. For example, if each chamber of the stacked GDT had an impulse sparkover voltage of 400 V, the total impulse sparkover for the entire GDT would be $5 \times 400\text{ V}$ (2000 V). In many cases, this higher sparkover voltage can have a negative impact to downstream components if their voltage sensitivity is less than the impulse sparkover of the stacked GDT.

Solution

High impulse sparkover can be improved by utilizing decoupling capacitors across 4 of 5 individual chambers of the stacked GDT. Typical capacitor values can range from 100 pF to 1 nF.

How it Works

In its initial state, all component values are zero. Under a fast rising voltage ramp condition, there is a capacitive voltage division across GDT1 and C1. During the voltage ramp, most of the voltage appears across GDT1. When the voltage across GDT1 reaches its sparkover voltage (400 V), the voltage across GDT1 drops to its arc voltage which is typically around 12 V.

As a result, the capacitor is charged to a value equaling the sparkover voltage less the arc voltage (example: $400\text{ V} - 12\text{ V} = 388\text{ V}$) which is then applied to GDT2. When GDT2 reaches 400 V, it then attains sparkover and the process repeats itself until GDT5 finally attains sparkover. This cascading turn-on mechanism of the capacitively coupled GDT chambers result in a significantly improved impulse sparkover voltage.

Results

In the table below, both 800 V and 1400 V stacked GDTs were compared using a $5\text{ kV}/\mu\text{s}$ voltage ramp. ITU K.12 recommends using a linear ramp as the best method for evaluating GDT impulse sparkover under fast rising voltage conditions. Impulse sparkover voltage limiting is significantly improved versus using the stacked GDT discretely. It should be noted that there is some improvement in impulse limiting by using a larger capacitor (1 nF). However, the improvement in impulse limiting must be measured against the cost of using a larger capacitor.

C1-C4 Capacitor Values	Model 2033-80 Typical Impulse Sparkover @ $5\text{ kV}/\mu\text{s}$	Model 2033-140 Typical Impulse Sparkover @ $5\text{ kV}/\mu\text{s}$
No Capacitor	2200 V	2400 V
100 pF	700 V	988 V
1 nF	600 V	886 V

NOTE: Impulse sparkover in the characteristic table on Page 1 is shown under combination wave conditions ($8/20\ \mu\text{s}$ current/ $1.2 \times 50\ \mu\text{s}$ voltage). This non-linear voltage condition will give results different than under a linear ramp speed. The typical values in the table above will differ.

Specifications are subject to change without notice.

The device characteristics and parameters in this data sheet can and do vary in different applications and actual device performance may vary over time. Users should verify actual device performance in their specific applications.

2033 Series Gas Discharge Tube Surge Protector

BOURNS®

Product Dimensions

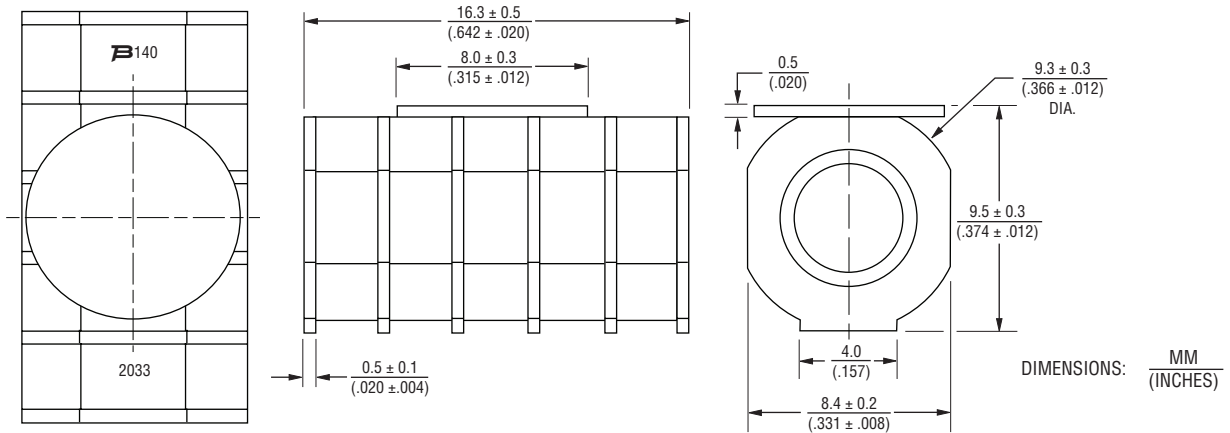

Recommended Pad Layout

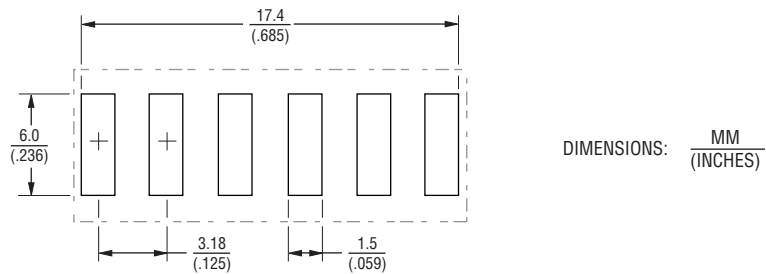

Packaging Specifications

The Model 2033-xx-G5 ships standard bulk, 100 pieces per plastic tray, 500 pieces per box.

Tape and Reel option available; 250 pieces per 13-inch reel.

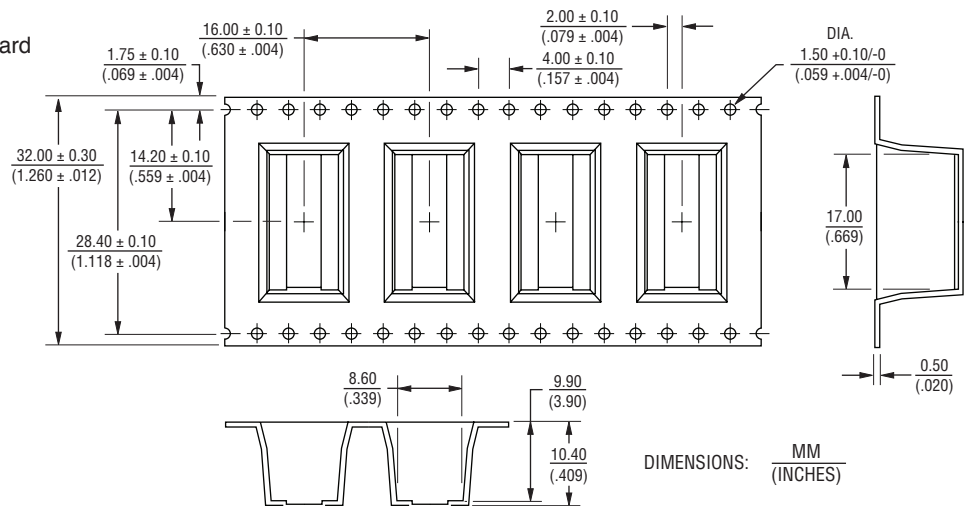

REV. A 02/18

Specifications are subject to change without notice.

The device characteristics and parameters in this data sheet can and do vary in different applications and actual device performance may vary over time. Users should verify actual device performance in their specific applications.



Компания «ЭлектроПласт» предлагает заключение долгосрочных отношений при поставках импортных электронных компонентов на взаимовыгодных условиях!

Наши преимущества:

- Оперативные поставки широкого спектра электронных компонентов отечественного и импортного производства напрямую от производителей и с крупнейших мировых складов;
- Поставка более 17-ти миллионов наименований электронных компонентов;
- Поставка сложных, дефицитных, либо снятых с производства позиций;
- Оперативные сроки поставки под заказ (от 5 рабочих дней);
- Экспресс доставка в любую точку России;
- Техническая поддержка проекта, помощь в подборе аналогов, поставка прототипов;
- Система менеджмента качества сертифицирована по Международному стандарту ISO 9001;
- Лицензия ФСБ на осуществление работ с использованием сведений, составляющих государственную тайну;
- Поставка специализированных компонентов (Xilinx, Altera, Analog Devices, Intersil, Interpoint, Microsemi, Aeroflex, Peregrine, Syfer, Eurofarad, Texas Instrument, Miteq, Cobham, E2V, MA-COM, Hittite, Mini-Circuits, General Dynamics и др.);

Помимо этого, одним из направлений компании «ЭлектроПласт» является направление «Источники питания». Мы предлагаем Вам помощь Конструкторского отдела:

- Подбор оптимального решения, техническое обоснование при выборе компонента;
- Подбор аналогов;
- Консультации по применению компонента;
- Поставка образцов и прототипов;
- Техническая поддержка проекта;
- Защита от снятия компонента с производства.



Как с нами связаться

Телефон: 8 (812) 309 58 32 (многоканальный)

Факс: 8 (812) 320-02-42

Электронная почта: org@eplast1.ru

Адрес: 198099, г. Санкт-Петербург, ул. Калинина, дом 2, корпус 4, литера А.