

THIS DRAWING IS UNPUBLISHED. RELEASED FOR PUBLICATION
 © COPYRIGHT - By - ALL RIGHTS RESERVED.

LOC		DIST		REVISIONS			
P	LTR	DESCRIPTION		DATE	DWN	APVD	
-	-	A		NEW DRAWING PER ECO-14-009318	10JUL2014	NK	RH

SPECIFICATIONS

MECHANICAL LIFE: 30,000 MAKE-AND-BREAK CYCLES.
 CONTACT RESISTANCE: 20 mΩ MAX. INITIAL @ 2-4VDC
 100mA FOR BOTH SILVER AND GOLD
 PLATED CONTACTS.
 CONTACT RATING: GOLD-0.4 VA MAX @ 20 V MAX (AC OR DC)
 SILVER-3 A @ 120 VAC OR 28 VDC
 1 A @ 250 VAC
 INSULATION RESISTANCE: 1,000 MΩ MIN.
 DIELECTRIC STRENGTH: 1,000 Vrms @SEA LEVEL.
 OPERATING TEMPERATURE: -30°C TO 85°C.

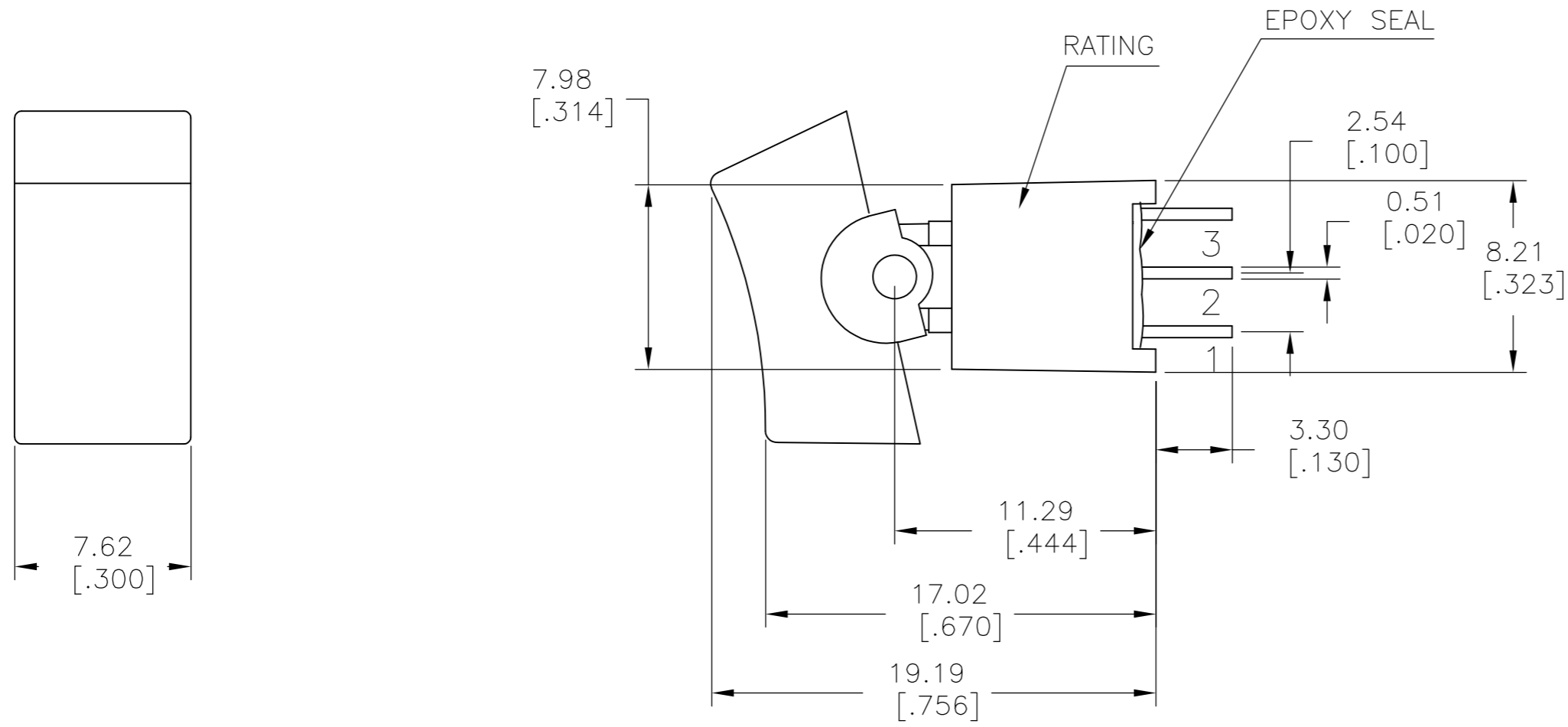

SILVER	2-1,5-4	2-3,5-6	ON-ON	V-BRACKET	VERTICAL	2	2	RAD1R102VS2QES	2267088-8
GOLD	2-1	2-3	ON-ON	V-BRACKET	VERTICAL	1	2	RAS1R102VS2RES	2267088-7
GOLD	2-1,5-4	2-3,5-6	ON-ON	PC THROUGH HOLE	VERTICAL RIGHT ANGLE	2	2	RAD1R102M7RES	2267088-6
GOLD	2-1	2-3	ON-ON	PC THROUGH HOLE	VERTICAL RIGHT ANGLE	1	2	RAS1R102M7RES	2267088-5
SILVER	2-1,5-4	2-3,5-6	ON-ON	PC THROUGH HOLE	RIGHT ANGLE	2	2	RAD1R102M6QES	2267088-4
SILVER	2-1	2-3	ON-ON	PC THROUGH HOLE	RIGHT ANGLE	1	2	RAS1R202M6QES	2267088-3
SILVER	2-1,5-4	2-3,5-6	ON-ON	PC THROUGH HOLE	VERTICAL	2	2	RAD1R102M2QES	2267088-2
GOLD	2-1	2-3	ON-ON	PC THROUGH HOLE	VERTICAL	1	2	RAS1R102M2RES	2267088-1
CONTACT MATERIAL	POS 2	POS 1	FUNCTION	TERMINATION	MOUNT ANGLE	POLES	THROWS	DESCRIPTIVE PN	TE PN

THIS DRAWING IS A CONTROLLED DOCUMENT.		DWN NAGALAKSHMI K 10JUL2014		
DIMENSIONS: mm [INCHES]		CHK HILL, RYAN 10JUL2014		
TOLERANCES UNLESS OTHERWISE SPECIFIED:		APVD HILL, RYAN 10JUL2014	NAME SUBMINIATURE ROCKER SWITCHES	
0 PLC ± -		PRODUCT SPEC	SIZE	
1 PLC ± 0.38[.015]		APPLICATION SPEC	CAGE CODE	
2 PLC ± 0.25[.010]			DRAWING NO	
3 PLC ± -			RESTRICTED TO	
4 PLC ± -			SCALE	
ANGLES ± 5°			SHEET	
MATERIAL	FINISH	WEIGHT	REV	
-	-	-	A	
CUSTOMER DRAWING			SCALE 3:1 SHEET 1 OF 5 REV A	

2267088

THIS DRAWING IS UNPUBLISHED. RELEASED FOR PUBLICATION
 © COPYRIGHT - By - ALL RIGHTS RESERVED.

LOC		DIST		REVISIONS			
P	LTR	DESCRIPTION	DATE	DWN	APVD		
-	-	SEE SHEET 1	-	-	-		

ACTUATOR OPTIONS

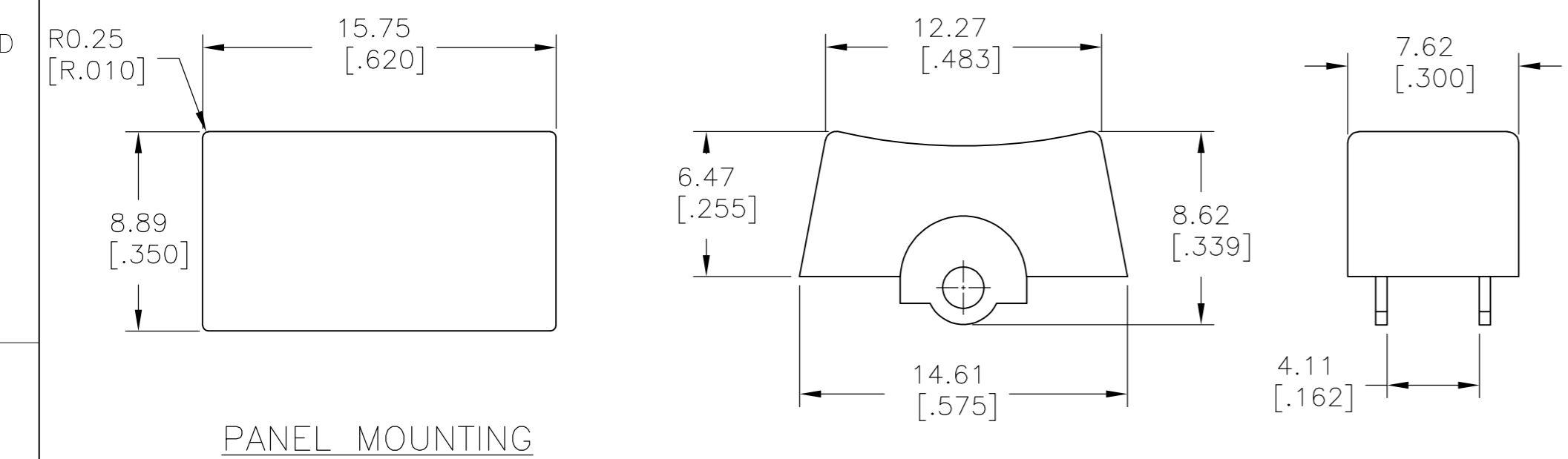

PANEL MOUNTING

R1
WIDE ACTUATOR

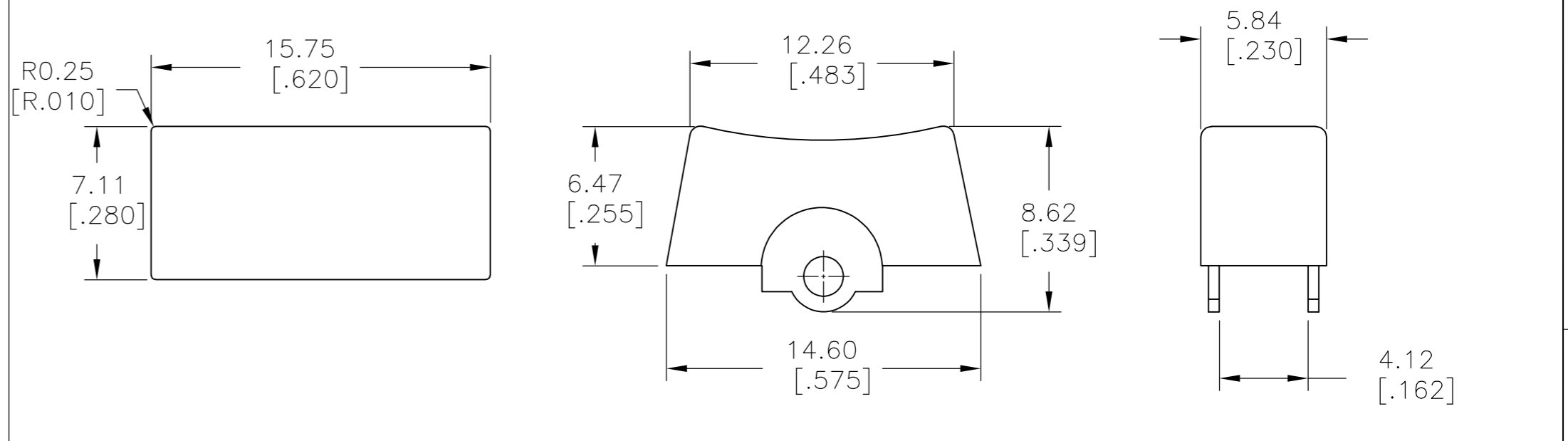

PANEL MOUNTING

R2
NARROW ACTUATOR

TERMINATION OPTIONS

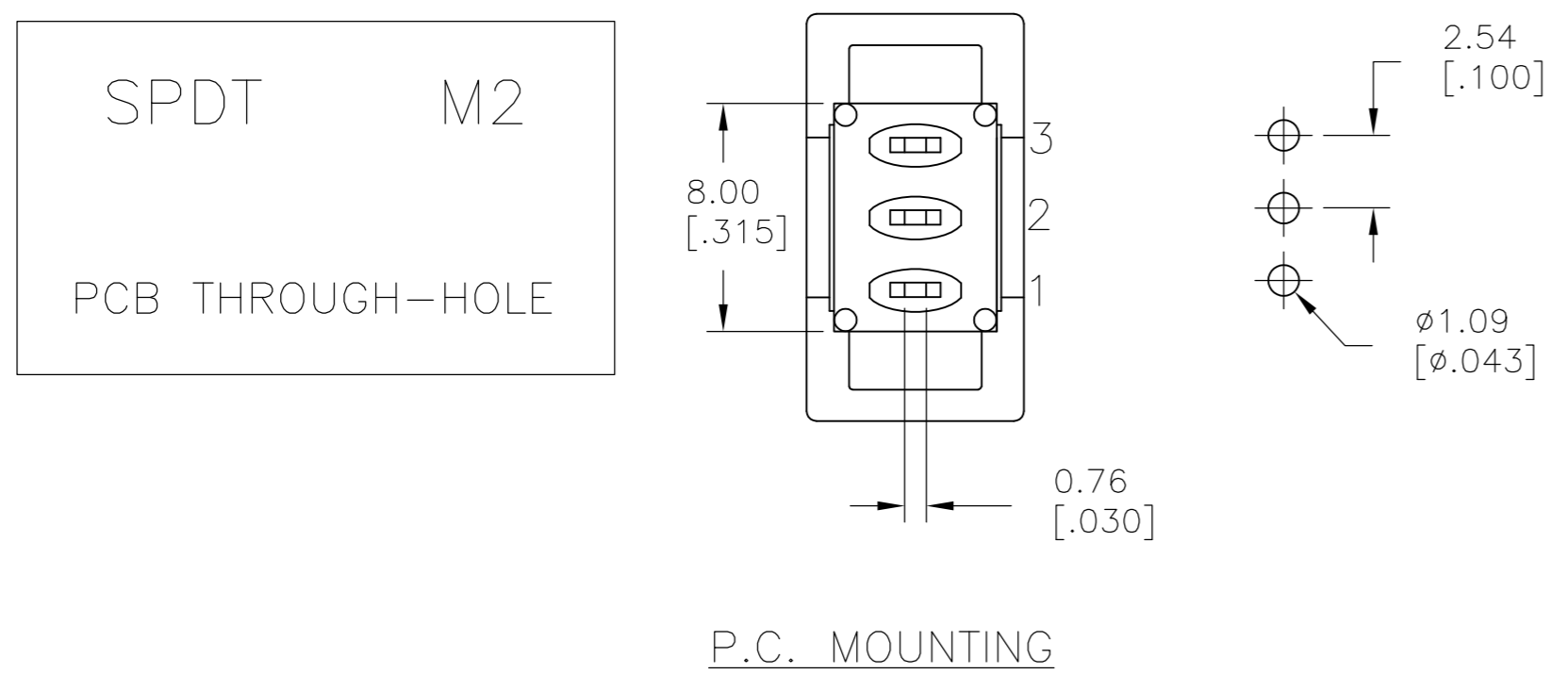

SPDT M2
PCB THROUGH-HOLE

P.C. MOUNTING

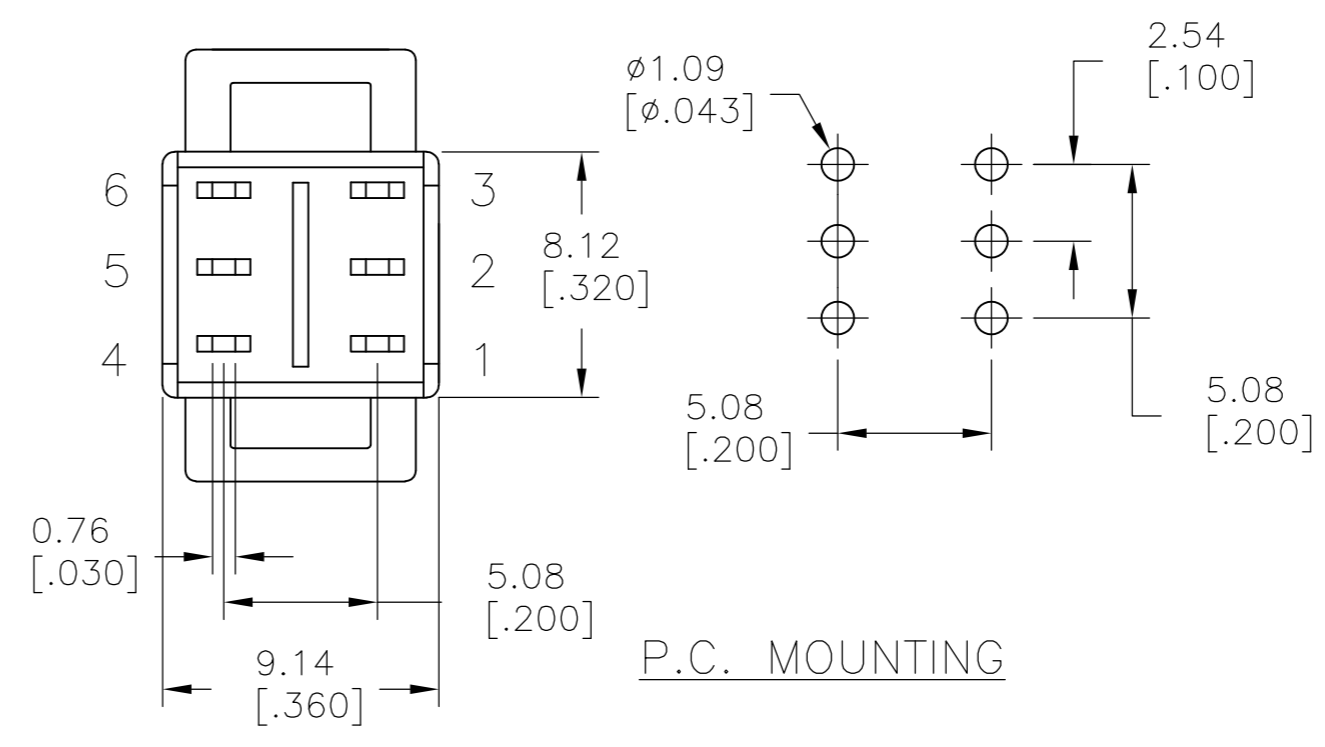

DPDT M2
PCB THROUGH-HOLE

P.C. MOUNTING

LAYOUT FOR PN 2267088-1 & 2

THIS DRAWING IS A CONTROLLED DOCUMENT.		DWN NAGALAKSHMI K 10JUL2014	TE Connectivity	
DIMENSIONS: mm [INCHES]		CHK HILL, RYAN 10JUL2014		
TOLERANCES UNLESS OTHERWISE SPECIFIED:		APVD HILL, RYAN 10JUL2014	NAME SUBMINIATURE ROCKER SWITCHES	
0 PLC ± - 1 PLC ± 0.38[.015] 2 PLC ± 0.25[.010] 3 PLC ± - 4 PLC ± - ANGLES ± 5°		PRODUCT SPEC	SIZE CAGE CODE DRAWING NO RESTRICTED TO	
MATERIAL		FINISH	A2 00779 C=2267088	
		WEIGHT	SCALE 3:1 SHEET 2 OF 5 REV A	
		CUSTOMER DRAWING		

THIS DRAWING IS UNPUBLISHED. RELEASED FOR PUBLICATION
 © COPYRIGHT - By - ALL RIGHTS RESERVED.

LOC		DIST		REVISIONS			
P	LTR	DESCRIPTION	DATE	DWN	APVD		
-	-	SEE SHEET 1	-	-	-		

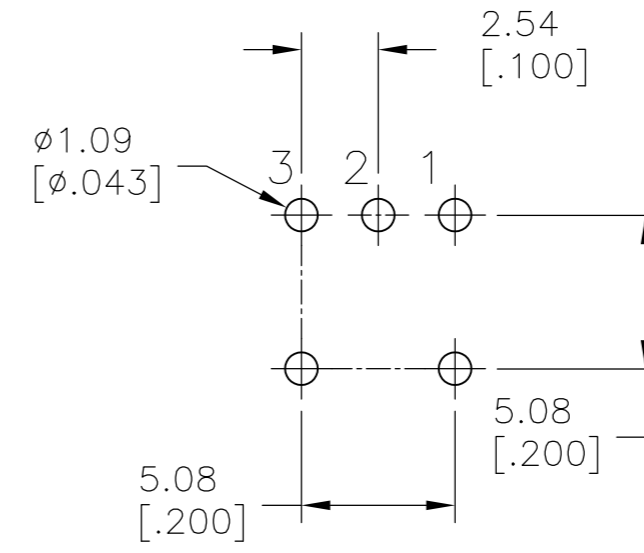
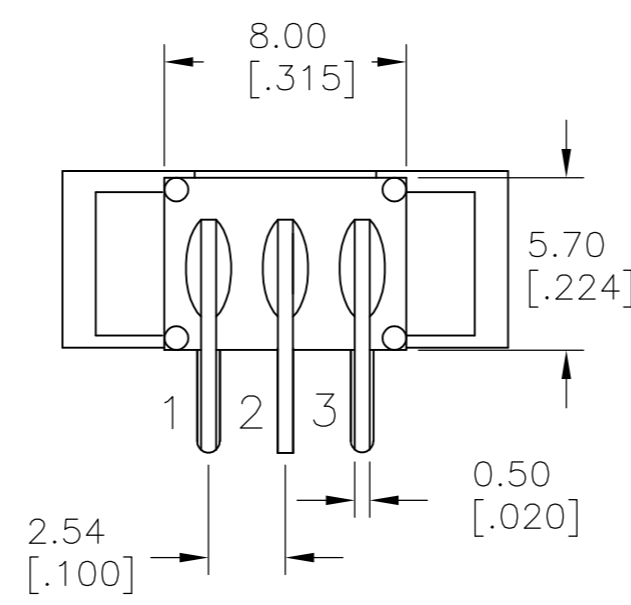
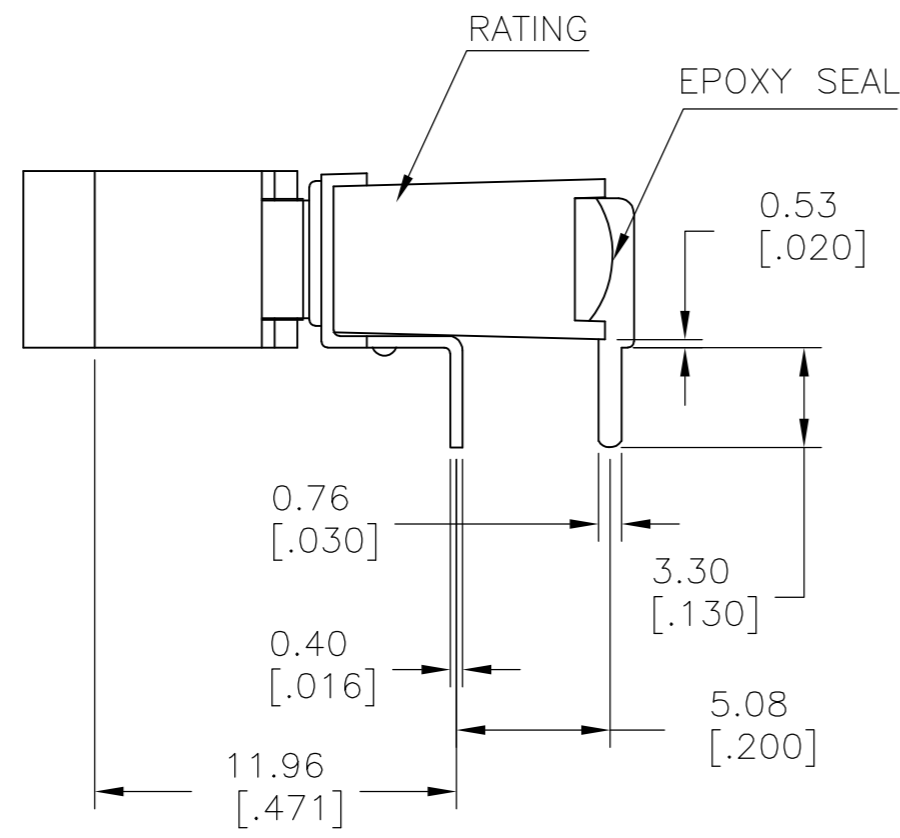
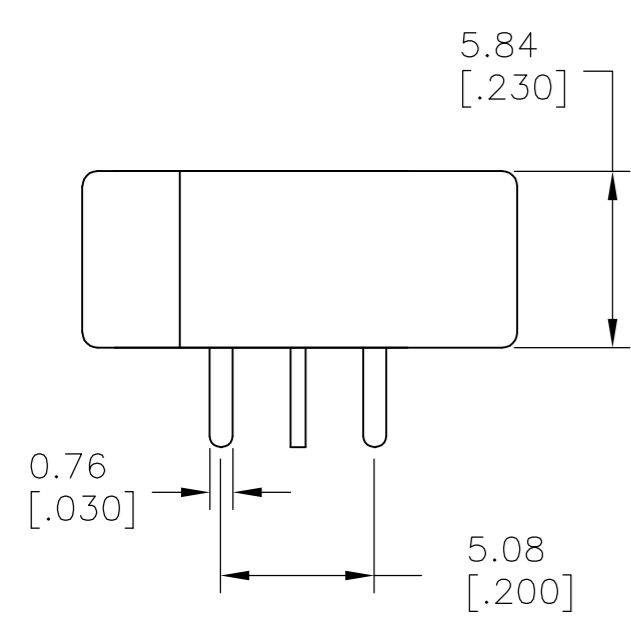

SPDT M6
 RIGHT ANGLE

P.C. MOUNTING

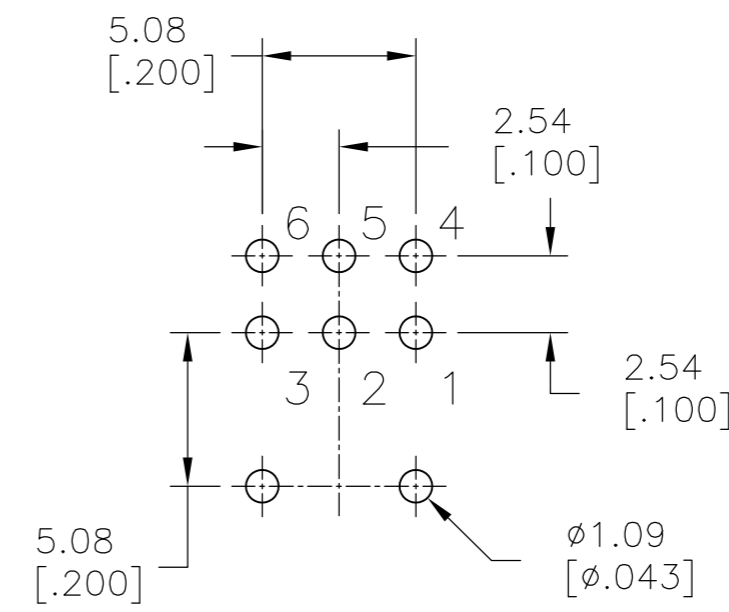
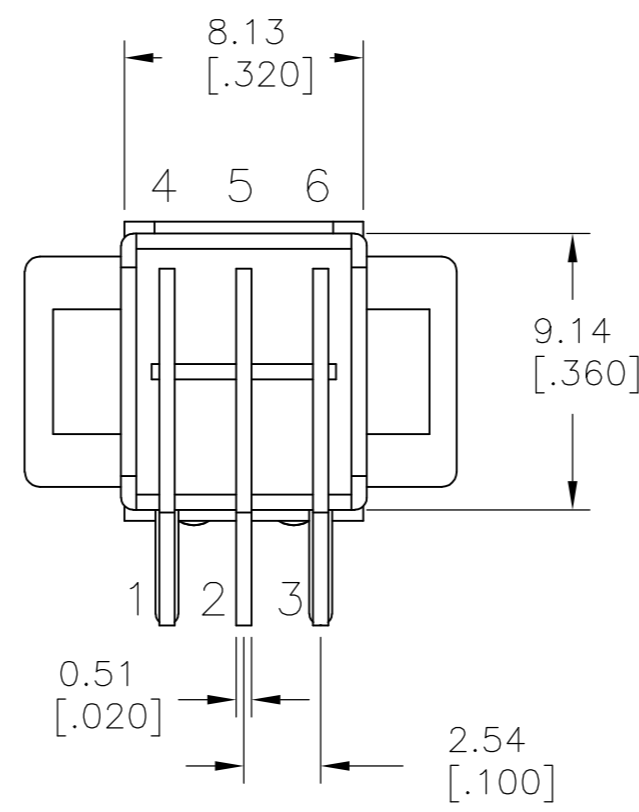
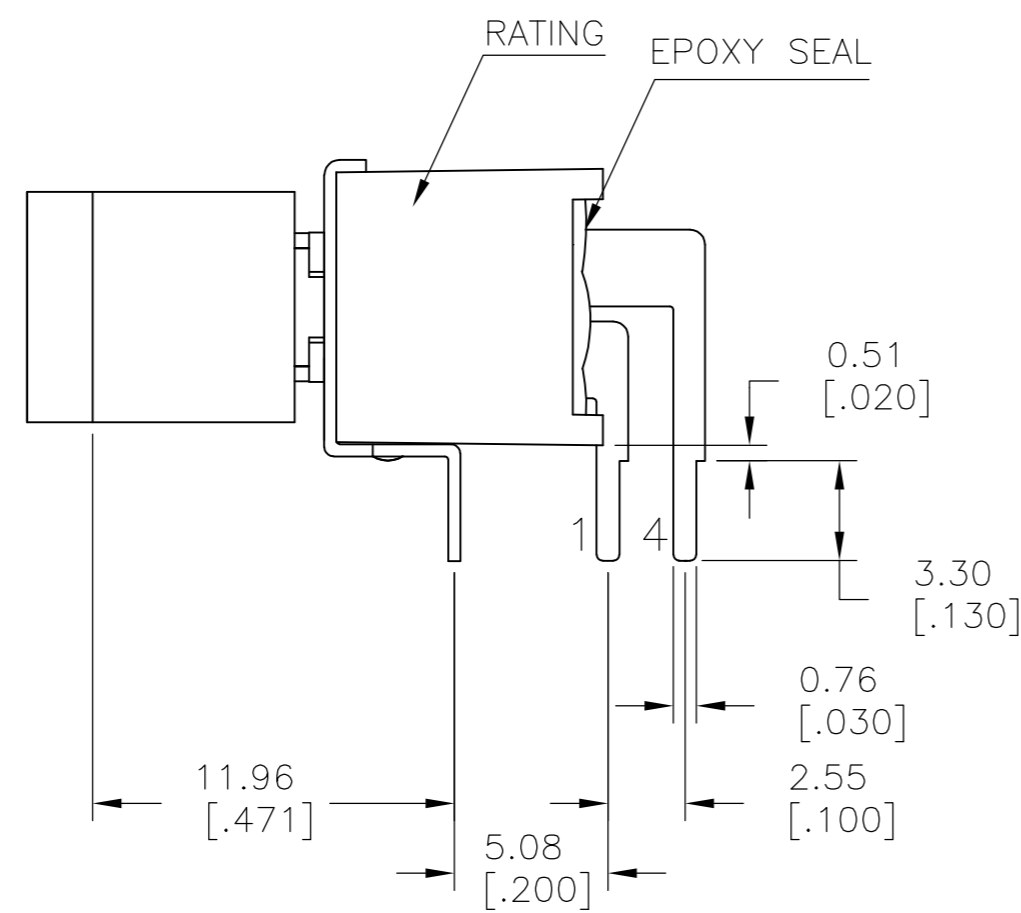
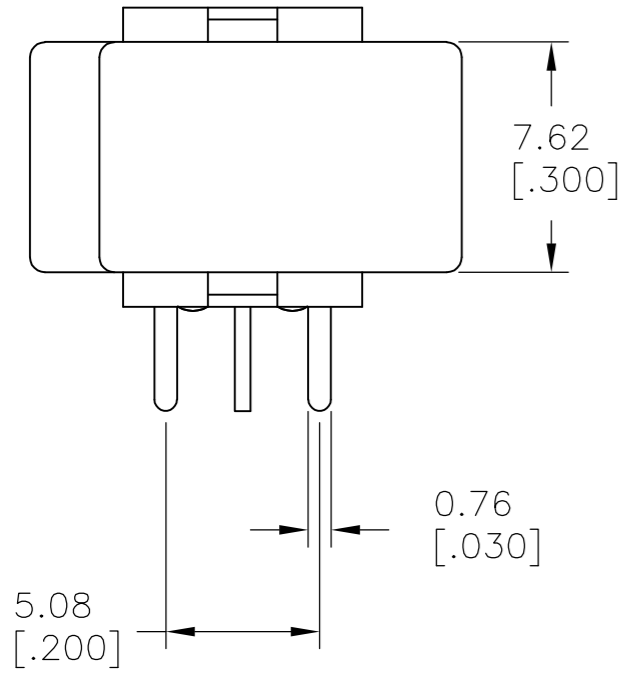

DPDT M6
 RIGHT ANGLE

P.C. MOUNTING

LAYOUT FOR PN 2267088-3 & 4

THIS DRAWING IS A CONTROLLED DOCUMENT.		DWN NAGALAKSHMI K 10JUL2014		
DIMENSIONS: mm [INCHES]		CHK HILL, RYAN 10JUL2014		
TOLERANCES UNLESS OTHERWISE SPECIFIED:		APVD HILL, RYAN 10JUL2014	NAME SUBMINIATURE ROCKER SWITCHES	
0 PLC ± - 1 PLC ± 0.38[.015] 2 PLC ± 0.25[.010] 3 PLC ± - 4 PLC ± - ANGLES ± 5°		PRODUCT SPEC	SIZE A2	
MATERIAL		APPLICATION SPEC	CAGE CODE 00779	DRAWING NO C=2267088
FINISH		WEIGHT	RESTRICTED TO	
		CUSTOMER DRAWING	SCALE 3:1	SHEET 3 OF 5
			REV A	

THIS DRAWING IS UNPUBLISHED. RELEASED FOR PUBLICATION
 © COPYRIGHT - By - ALL RIGHTS RESERVED.

LOC		DIST		REVISIONS			
P	LTR	DESCRIPTION	DATE	DWN	APVD		
-	-	SEE SHEET 1	-	-	-		

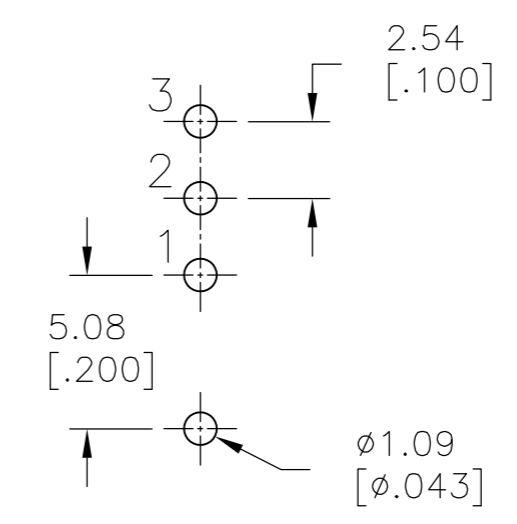
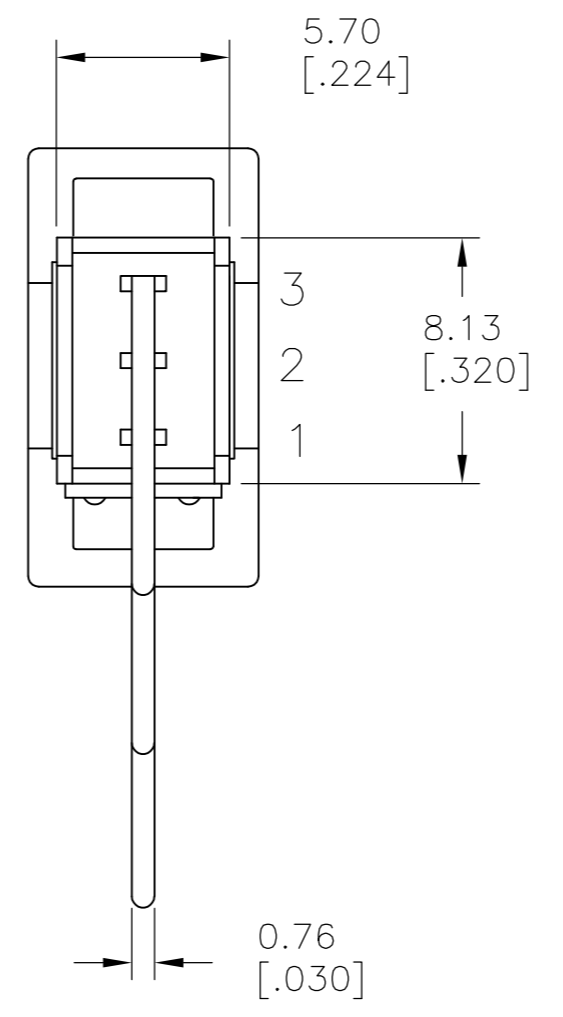
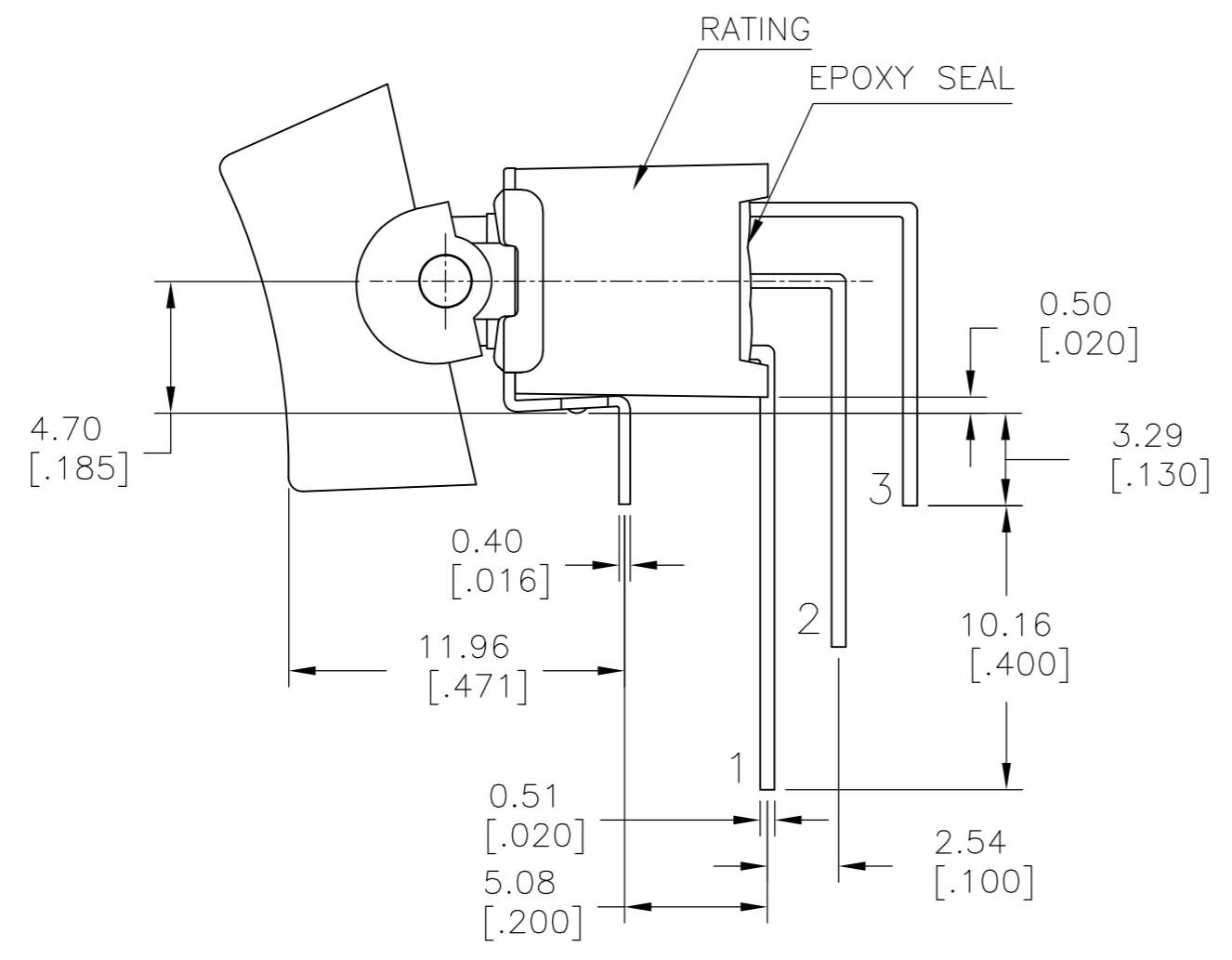
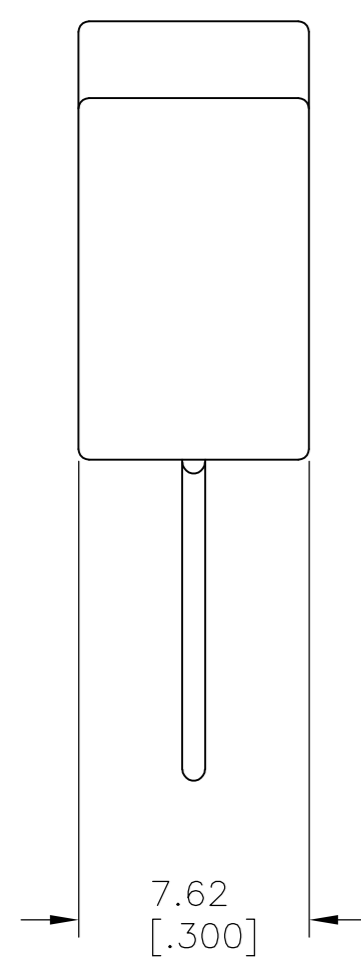

SPDT M7
 VERTICAL
 RIGHT ANGLE

P.C. MOUNTING

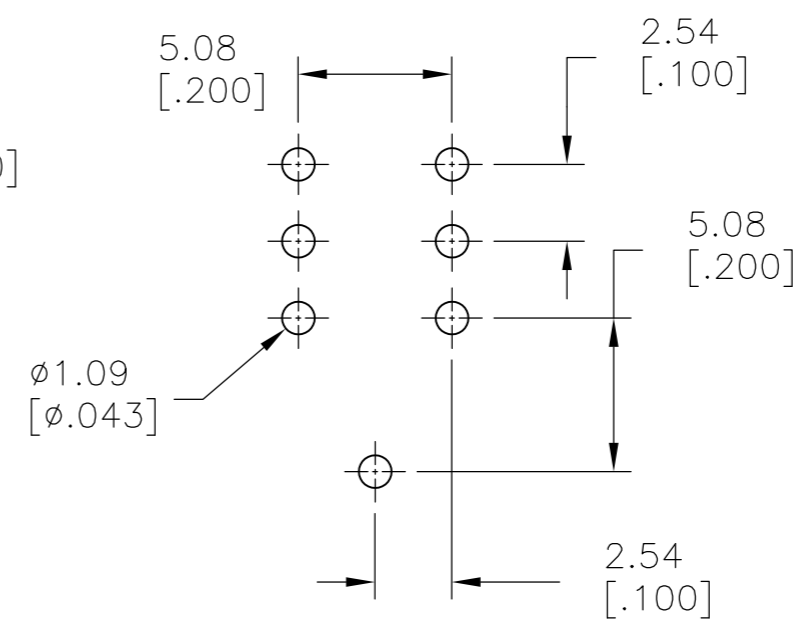
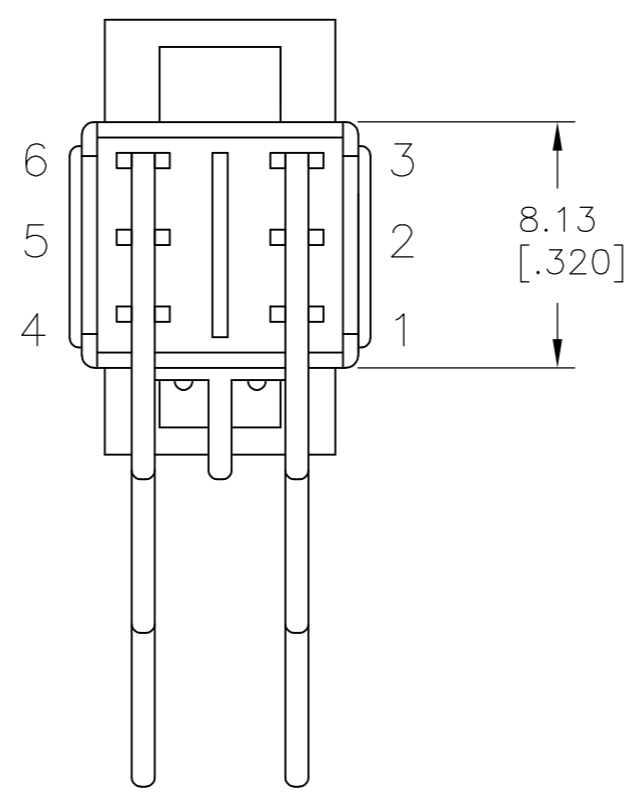
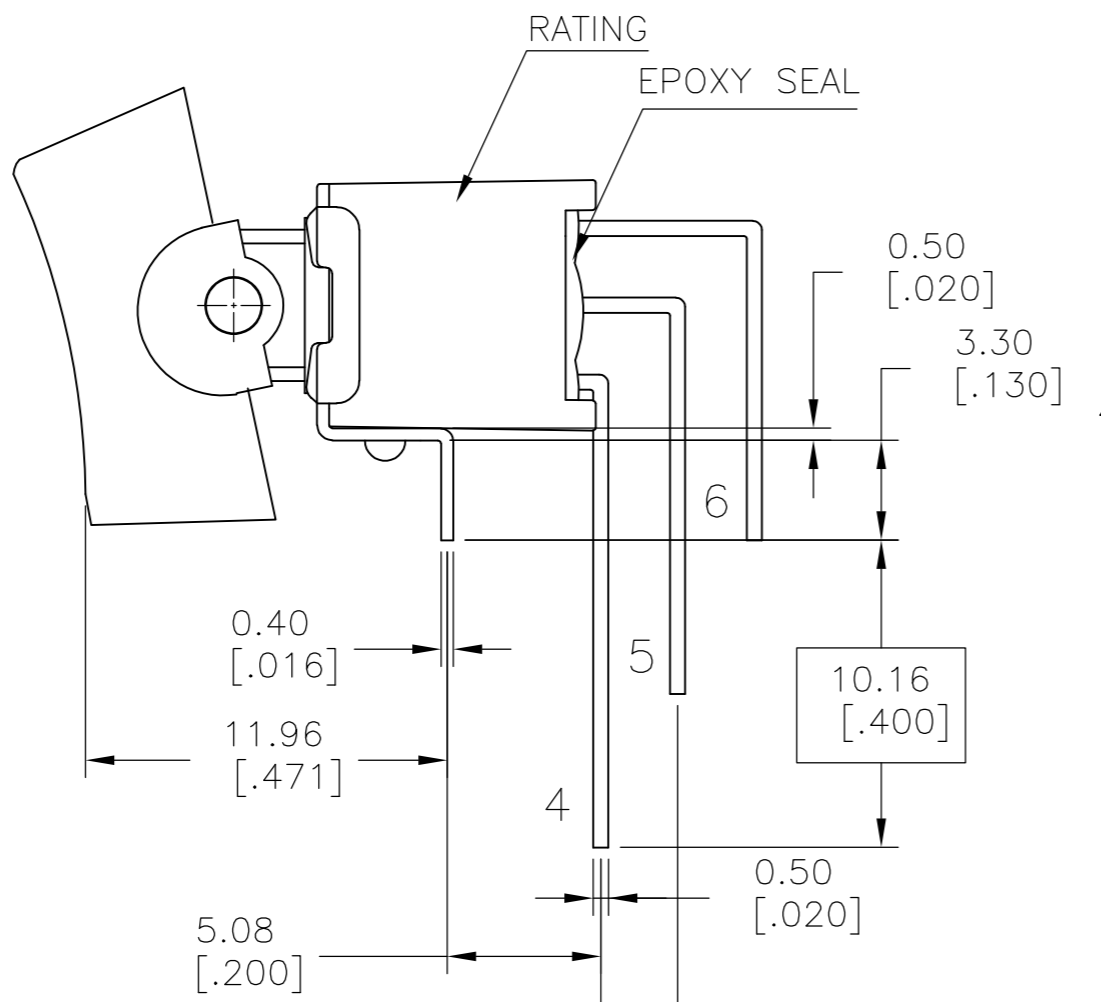
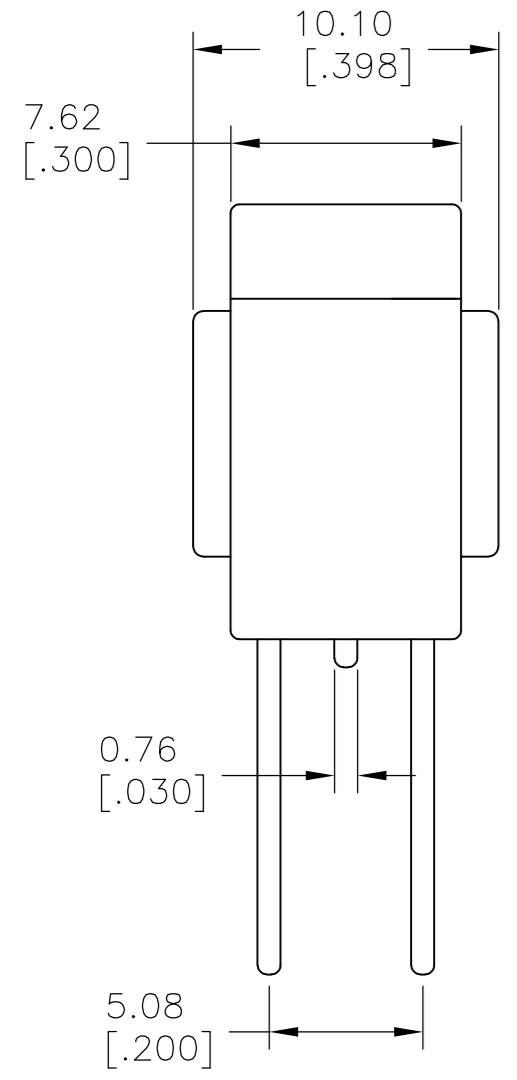

DPDT M7
 VERTICAL
 RIGHT ANGLE

P.C. MOUNTING

LAYOUT FOR PN 2267088-5 & 6

THIS DRAWING IS A CONTROLLED DOCUMENT.		DWN NAGALAKSHMI K 10JUL2014	TE Connectivity	
DIMENSIONS: mm [INCHES]		CHK HILL, RYAN 10JUL2014		
TOLERANCES UNLESS OTHERWISE SPECIFIED:		APVD HILL, RYAN 10JUL2014	NAME SUBMINIATURE ROCKER SWITCHES	
0 PLC ± - 1 PLC ± 0.38[015] 2 PLC ± 0.25[010] 3 PLC ± - 4 PLC ± - ANGLES ± 5°		PRODUCT SPEC	RESTRICTED TO	
MATERIAL		APPLICATION SPEC	SIZE A2	CAGE CODE 00779
FINISH		WEIGHT	DRAWING NO C=2267088	SCALE 3:1
		CUSTOMER DRAWING	SHEET 4 OF 5	REV A

THIS DRAWING IS UNPUBLISHED. RELEASED FOR PUBLICATION
 © COPYRIGHT - By - ALL RIGHTS RESERVED.

LOC		DIST		REVISIONS			
P	LTR	DESCRIPTION	DATE	DWN	APVD		
-	-	SEE SHEET 1	-	-	-		

D

C

B

A

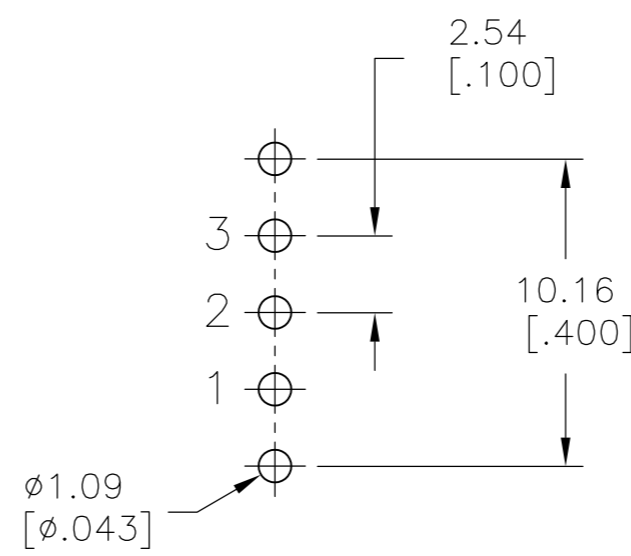
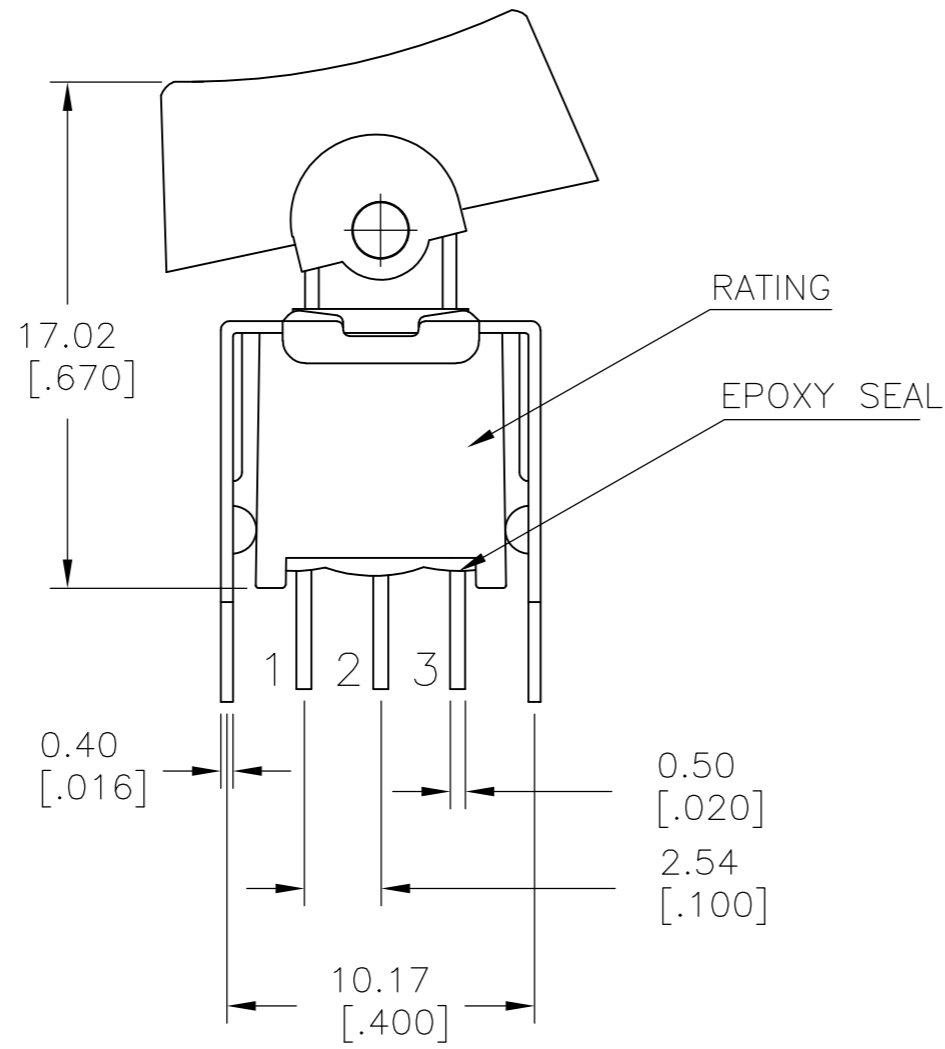
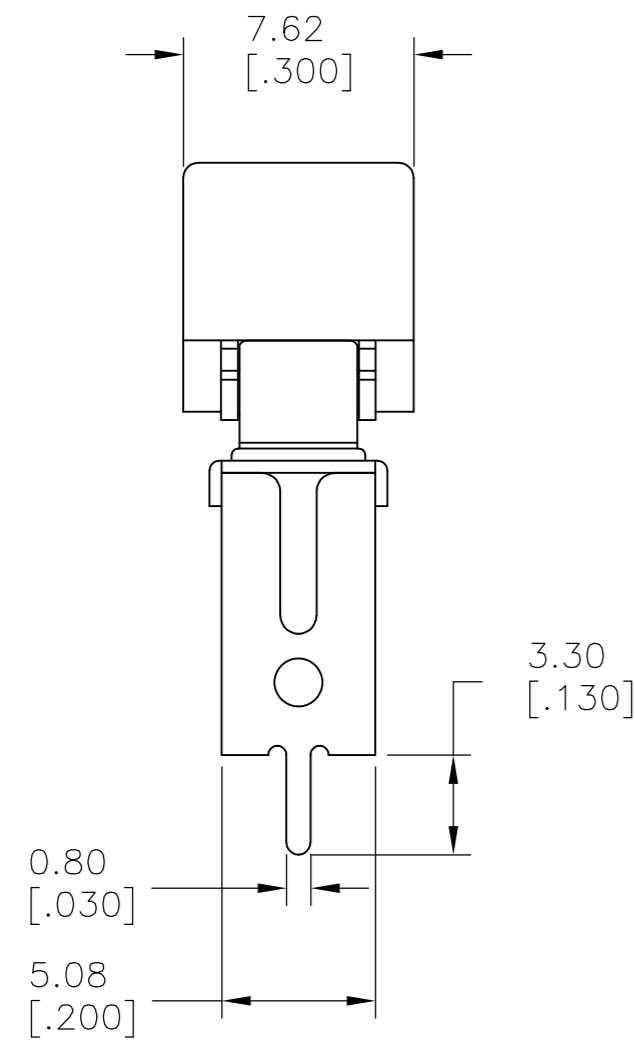

SPDT VS2
 VERTICAL V-BRACKET

P.C. MOUNTING

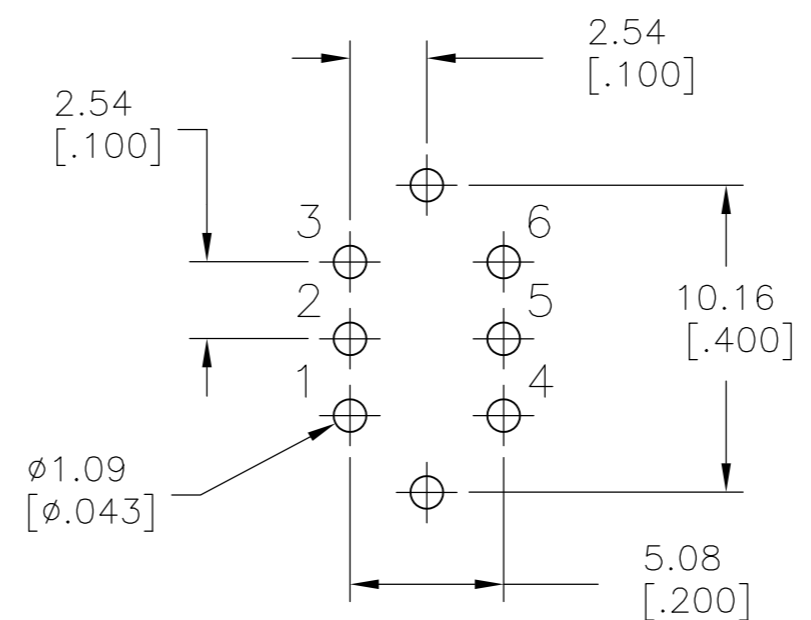
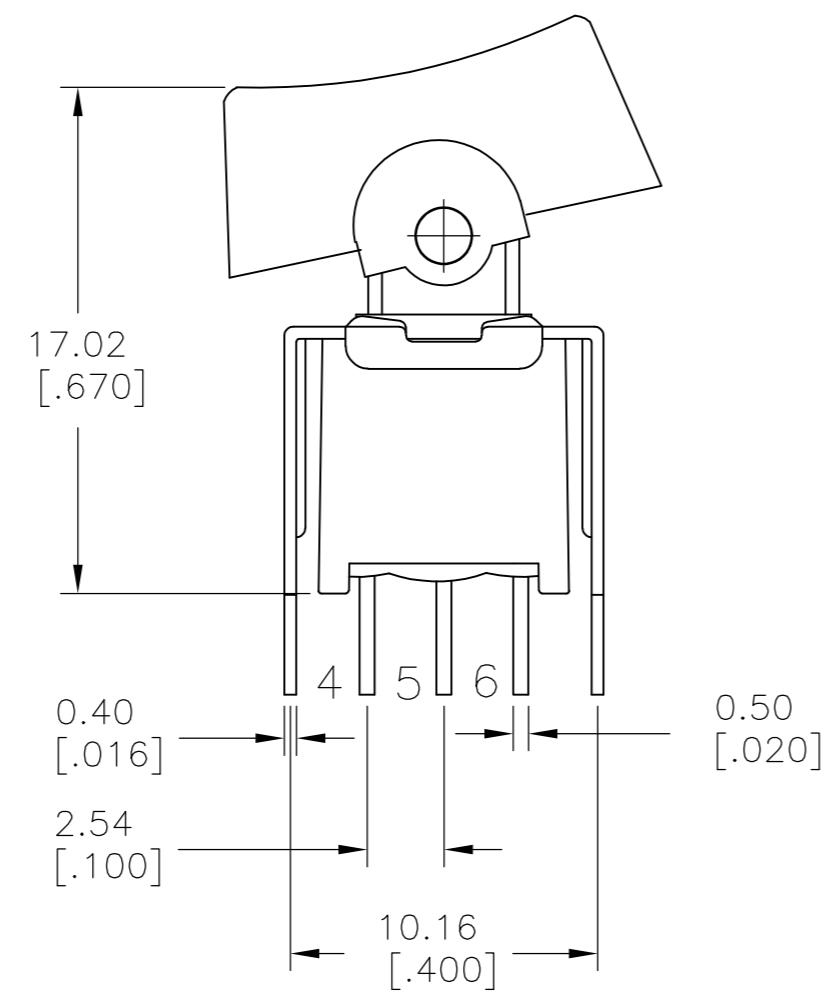
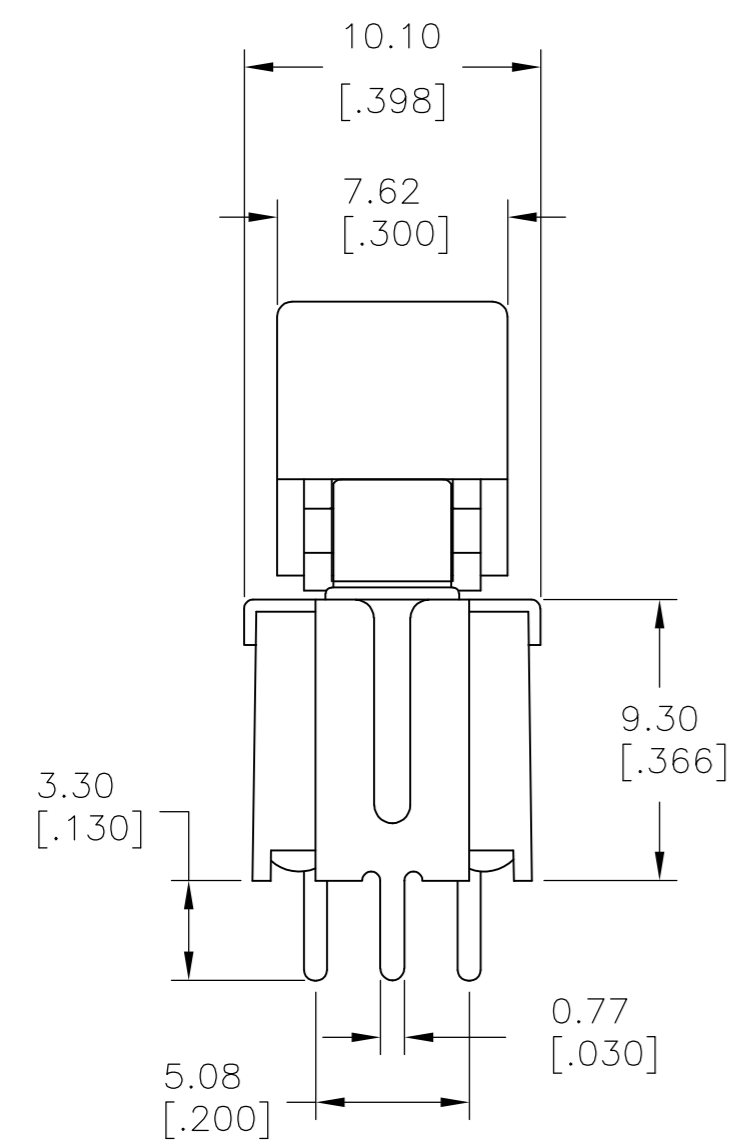

DPDT VS2
 VERTICAL V-BRACKET

P.C. MOUNTING

LAYOUT FOR PN 2267088-7 & 8

THIS DRAWING IS A CONTROLLED DOCUMENT.		DWN NAGALAKSHMI K 10JUL2014																				
DIMENSIONS: mm [INCHES]		CHK HILL, RYAN 10JUL2014																				
TOLERANCES UNLESS OTHERWISE SPECIFIED:		APVD HILL, RYAN 10JUL2014	NAME SUBMINIATURE ROCKER SWITCHES																			
<table border="1"> <tr><td>0 PLC</td><td>±</td><td>-</td></tr> <tr><td>1 PLC</td><td>±</td><td>0.38[.015]</td></tr> <tr><td>2 PLC</td><td>±</td><td>0.25[.010]</td></tr> <tr><td>3 PLC</td><td>±</td><td>-</td></tr> <tr><td>4 PLC</td><td>±</td><td>-</td></tr> <tr><td>ANGLES</td><td>±</td><td>5°</td></tr> </table>		0 PLC	±	-	1 PLC	±	0.38[.015]	2 PLC	±	0.25[.010]	3 PLC	±	-	4 PLC	±	-	ANGLES	±	5°	PRODUCT SPEC -	SIZE A2	
0 PLC	±	-																				
1 PLC	±	0.38[.015]																				
2 PLC	±	0.25[.010]																				
3 PLC	±	-																				
4 PLC	±	-																				
ANGLES	±	5°																				
MATERIAL -		APPLICATION SPEC -	CAGE CODE 00779	DRAWING NO C=2267088	RESTRICTED TO -																	
FINISH -		WEIGHT -	SCALE 3:1		SHEET 5 of 5																	
		CUSTOMER DRAWING		REV A																		



Компания «ЭлектроПласт» предлагает заключение долгосрочных отношений при поставках импортных электронных компонентов на взаимовыгодных условиях!

Наши преимущества:

- Оперативные поставки широкого спектра электронных компонентов отечественного и импортного производства напрямую от производителей и с крупнейших мировых складов;
- Поставка более 17-ти миллионов наименований электронных компонентов;
- Поставка сложных, дефицитных, либо снятых с производства позиций;
- Оперативные сроки поставки под заказ (от 5 рабочих дней);
- Экспресс доставка в любую точку России;
- Техническая поддержка проекта, помощь в подборе аналогов, поставка прототипов;
- Система менеджмента качества сертифицирована по Международному стандарту ISO 9001;
- Лицензия ФСБ на осуществление работ с использованием сведений, составляющих государственную тайну;
- Поставка специализированных компонентов (Xilinx, Altera, Analog Devices, Intersil, Interpoint, Microsemi, Aeroflex, Peregrine, Syfer, Eurofarad, Texas Instrument, Miteq, Cobham, E2V, MA-COM, Hittite, Mini-Circuits, General Dynamics и др.);

Помимо этого, одним из направлений компании «ЭлектроПласт» является направление «Источники питания». Мы предлагаем Вам помощь Конструкторского отдела:

- Подбор оптимального решения, техническое обоснование при выборе компонента;
- Подбор аналогов;
- Консультации по применению компонента;
- Поставка образцов и прототипов;
- Техническая поддержка проекта;
- Защита от снятия компонента с производства.



Как с нами связаться

Телефон: 8 (812) 309 58 32 (многоканальный)

Факс: 8 (812) 320-02-42

Электронная почта: org@eplast1.ru

Адрес: 198099, г. Санкт-Петербург, ул. Калинина, дом 2, корпус 4, литера А.