

High-Voltage Input Integrated Switch Step-Down Regulator

Features

- Up to 96% Typical Efficiency
- Input Voltage Range: 4.0V to 30V
- Output Voltage Range: 2.0V to 15V
- 2% Output Voltage Accuracy
- Integrated N-Channel Buck Switch: 460 mΩ
- 600 mA Output Current
- 500 kHz Fixed Frequency
- Adjustable Output Voltage
- Low Device Shutdown Current
- Peak Current Mode Control
- Internal Compensation
- Stable with Ceramic Capacitors
- Internal Soft-Start
- Cycle-by-Cycle Peak Current Limit
- Under Voltage Lockout (UVLO): 3.5V
- Overtemperature Protection
- Available Package: SOT-23-6

Applications

- PIC[®]/dsPIC[®] Microcontroller Bias Supply
- 24V Industrial Input DC-DC Conversion
- Set-Top Boxes
- DSL Cable Modems
- Automotive
- Wall Cube Regulation
- SLA Battery Powered Devices
- AC-DC Digital Control Power Source
- Power Meters
- D² Package Linear Regulator Replacement
 - See [Figure 5-2](#)
- Consumer
- Medical and Health Care
- Distributed Power Supplies

General Description

The MCP16301 is a highly integrated, high-efficiency, fixed frequency, step-down DC-DC converter in a popular 6-pin SOT-23 package that operates from input voltage sources up to 30V. Integrated features include a high-side switch, fixed frequency Peak Current Mode Control, internal compensation, peak current limit and overtemperature protection. Minimal external components are necessary to develop a complete step-down DC-DC converter power supply.

High converter efficiency is achieved by integrating the current limited, low resistance, high-speed N-Channel MOSFET and associated drive circuitry. High switching frequency minimizes the size of external filtering components, resulting in a small solution size.

The MCP16301 can supply 600 mA of continuous current while regulating the output voltage from 2.0V to 15V. An integrated, high-performance peak current mode architecture keeps the output voltage tightly regulated, even during input voltage steps and output current transient conditions that are common in power systems.

The EN input is used to turn the device on and off. While turned off, only a few micro amps of current are consumed from the input for power shedding and load distribution applications.

Output voltage is set with an external resistor divider. The MCP16301 is offered in a space saving SOT-23-6 surface mount package.

Package Type

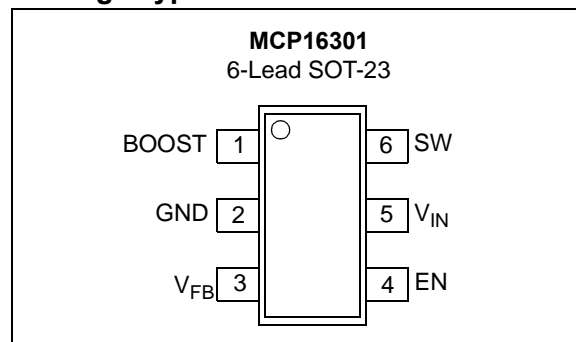

MCP16301

Typical Applications

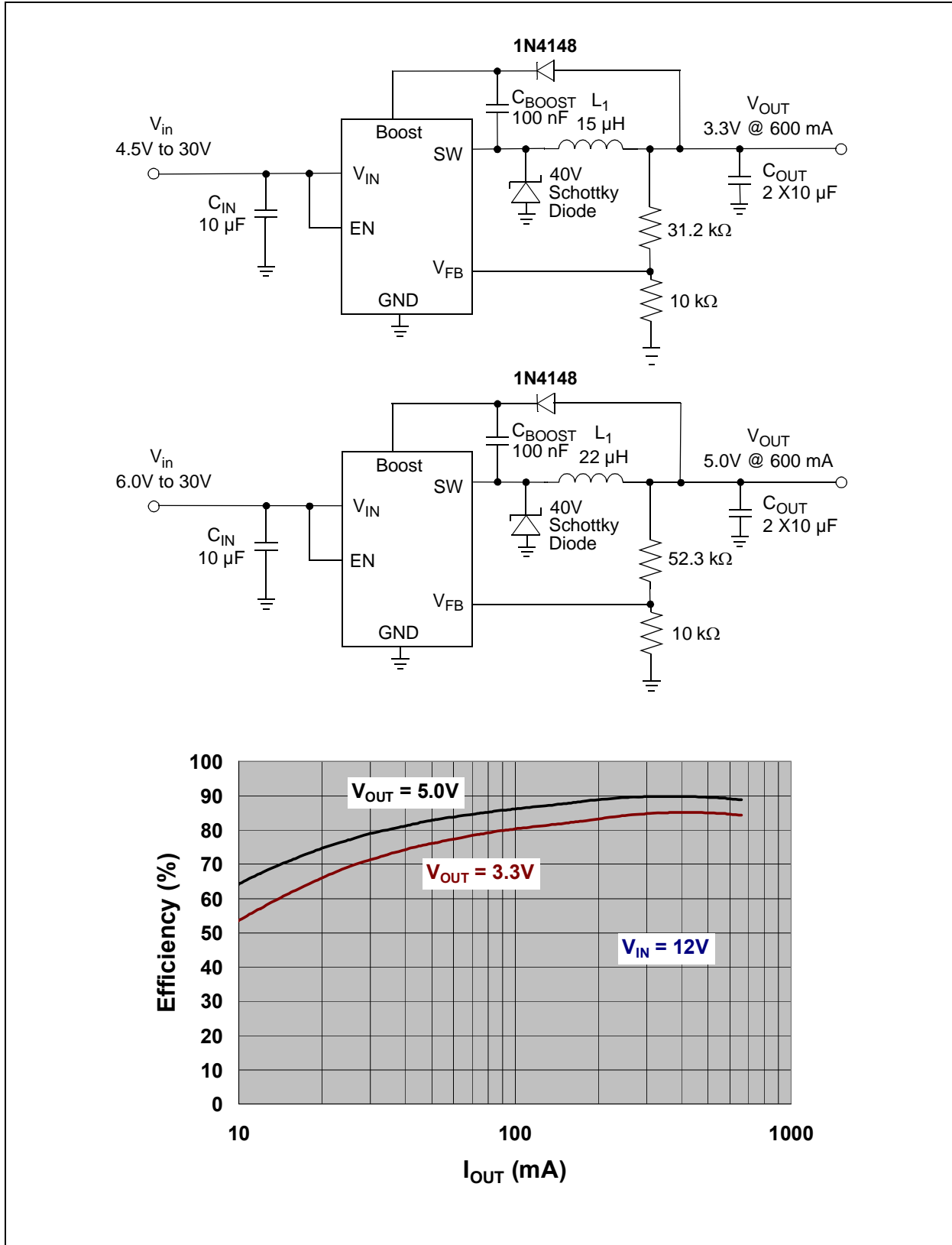

1.0 ELECTRICAL CHARACTERISTICS

Absolute Maximum Ratings †

$V_{IN, SW}$	-0.5V to 40V
BOOST – GND	-0.5V to 46V
BOOST – SW Voltage.....	-0.5V to 6.0V
V_{FB} Voltage	-0.5V to 6.0V
EN Voltage	-0.5V to ($V_{IN} + 0.3V$)
Output Short Circuit Current	Continuous
Power Dissipation	Internally Limited
Storage Temperature	-65°C to +150°C
Ambient Temperature with Power Applied ...	-40°C to +125°C
Operating Junction Temperature.....	-40°C to +125°C
ESD Protection On All Pins:	
HBM.....	3 kV
MM.....	200 V

† **Notice:** Stresses above those listed under “Maximum Ratings” may cause permanent damage to the device. This is a stress rating only and functional operation of the device at those or any other conditions above those indicated in the operational sections of this specification is not intended. Exposure to maximum rating conditions for extended periods may affect device reliability.

DC CHARACTERISTICS

Electrical Characteristics: Unless otherwise indicated, $T_A = +25^\circ\text{C}$, $V_{IN} = V_{EN} = 12V$, $V_{BOOST} - V_{SW} = 3.3V$, $V_{OUT} = 3.3V$, $I_{OUT} = 100\text{ mA}$, $L = 15\ \mu\text{H}$, $C_{OUT} = C_{IN} = 2\ \text{X}\ 10\ \mu\text{F}\ \text{X7R}$ Ceramic Capacitors
Boldface specifications apply over the T_A range of -40°C to $+125^\circ\text{C}$.

Parameters	Sym	Min	Typ	Max	Units	Conditions
Input Voltage	V_{IN}	—	4.0	30	V	Note 1
Feedback Voltage	V_{FB}	0.784	0.800	0.816	V	
Output Voltage Adjust Range	V_{OUT}	2.0	—	15.0	V	Note 2
Feedback Voltage Line Regulation	$(\Delta V_{FB}/V_{FB})/\Delta V_{IN}$	—	0.01	0.1	%/V	$V_{IN} = 12V$ to $30V$;
Feedback Input Bias Current	I_{FB}	-250	± 10	+250	nA	
Undervoltage Lockout Start	$UVLO_{STRT}$	—	3.5	4.0	V	V_{IN} Rising
Undervoltage Lockout Stop	$UVLO_{STOP}$	2.4	3.0	—	V	V_{IN} Falling
Undervoltage Lockout Hysteresis	$UVLO_{HYS}$	—	0.4	—	V	
Switching Frequency	f_{SW}	425	500	550	kHz	$I_{OUT} = 200\text{ mA}$
Maximum Duty Cycle	DC_{MAX}	90	95	—	%	$V_{IN} = 5V$; $V_{FB} = 0.7V$; $I_{OUT} = 100\text{ mA}$
Minimum Duty Cycle	DC_{MIN}	—	1	—	%	
NMOS Switch On Resistance	$R_{DS(ON)}$	—	0.46	—	Ω	$V_{BOOST} - V_{SW} = 3.3V$
NMOS Switch Current Limit	$I_{N(MAX)}$	—	1.3	—	A	$V_{BOOST} - V_{SW} = 3.3V$
Quiescent Current	I_Q	—	2	7.5	mA	$V_{BOOST} = 3.3V$; Note 3
Quiescent Current - Shutdown	I_Q	—	7	10	μA	$V_{OUT} = EN = 0V$
Maximum Output Current	I_{OUT}	600	—	—	mA	Note 1
EN Input Logic High	V_{IH}	1.4	—	—	V	
EN Input Logic Low	V_{IL}	—	—	0.4	V	
EN Input Leakage Current	I_{ENLK}	—	0.05	1.0	μA	$V_{EN} = 12V$
Soft-Start Time	t_{SS}	—	150	—	μS	EN Low to High, 90% of V_{OUT}

Note 1: The input voltage should be $>$ output voltage + headroom voltage; higher load currents increase the input voltage necessary for regulation. See characterization graphs for typical input to output operating voltage range.

2: For $V_{IN} < V_{OUT}$, V_{OUT} will not remain in regulation.

3: V_{BOOST} supply is derived from V_{OUT} .

MCP16301

DC CHARACTERISTICS (CONTINUED)

Electrical Characteristics: Unless otherwise indicated, $T_A = +25^\circ\text{C}$, $V_{IN} = V_{EN} = 12\text{V}$, $V_{BOOST} - V_{SW} = 3.3\text{V}$, $V_{OUT} = 3.3\text{V}$, $I_{OUT} = 100\text{ mA}$, $L = 15\ \mu\text{H}$, $C_{OUT} = C_{IN} = 2 \times 10\ \mu\text{F X7R Ceramic Capacitors}$
Boldface specifications apply over the T_A range of -40°C to $+125^\circ\text{C}$.

Parameters	Sym	Min	Typ	Max	Units	Conditions
Thermal Shutdown Die Temperature	T_{SD}	—	150	—	$^\circ\text{C}$	
Die Temperature Hysteresis	T_{SDHYS}	—	30	—	$^\circ\text{C}$	

- Note** 1: The input voltage should be $>$ output voltage + headroom voltage; higher load currents increase the input voltage necessary for regulation. See characterization graphs for typical input to output operating voltage range.
2: For $V_{IN} < V_{OUT}$, V_{OUT} will not remain in regulation.
3: V_{BOOST} supply is derived from V_{OUT} .

TEMPERATURE SPECIFICATIONS

Electrical Specifications:						
Parameters	Sym	Min	Typ	Max	Units	Conditions
Temperature Ranges						
Operating Junction Temperature Range	T_J	-40	—	+125	$^\circ\text{C}$	Steady State
Storage Temperature Range	T_A	-65	—	+150	$^\circ\text{C}$	
Maximum Junction Temperature	T_J	—	—	+150	$^\circ\text{C}$	Transient
Package Thermal Resistances						
Thermal Resistance, 6L-SOT-23	θ_{JA}	—	190.5	—	$^\circ\text{C/W}$	EIA/JESD51-3 Standard

2.0 TYPICAL PERFORMANCE CURVES

Note: The graphs and tables provided following this note are a statistical summary based on a limited number of samples and are provided for informational purposes only. The performance characteristics listed herein are not tested or guaranteed. In some graphs or tables, the data presented may be outside the specified operating range (e.g., outside specified power supply range) and therefore outside the warranted range.

Note: Unless otherwise indicated, $V_{IN} = EN = 12V$, $C_{OUT} = C_{IN} = 2 \times 10 \mu F$, $L = 15 \mu H$, $V_{OUT} = 3.3V$, $I_{LOAD} = 200 \text{ mA}$, $T_A = +25^\circ C$.

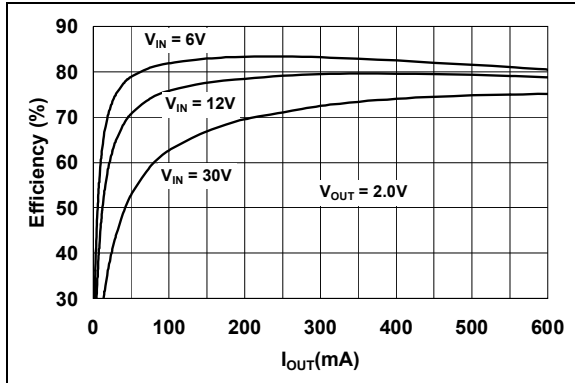

FIGURE 2-1: 2.0V V_{OUT} Efficiency vs. I_{OUT} .

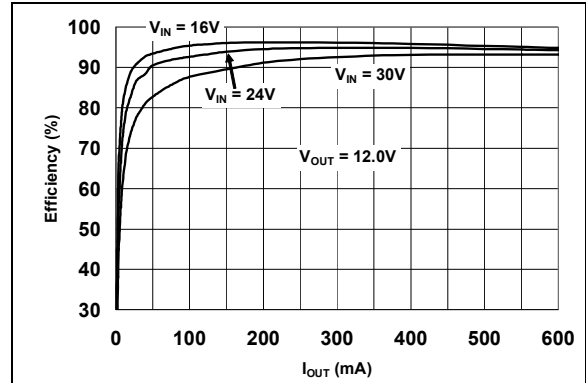

FIGURE 2-4: 12V V_{OUT} Efficiency vs. I_{OUT} .

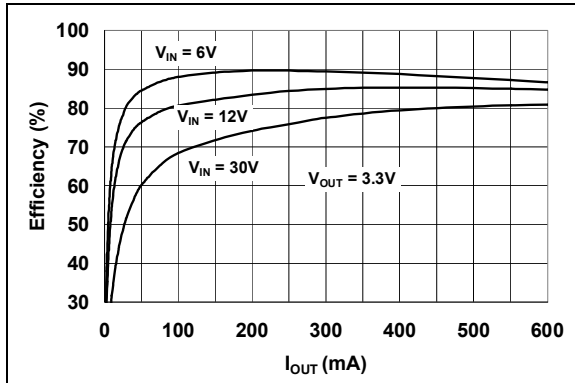

FIGURE 2-2: 3.3V V_{OUT} Efficiency vs. I_{OUT} .

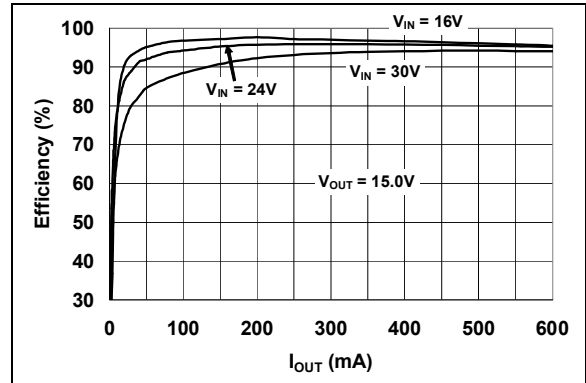

FIGURE 2-5: 15V V_{OUT} Efficiency vs. I_{OUT} .

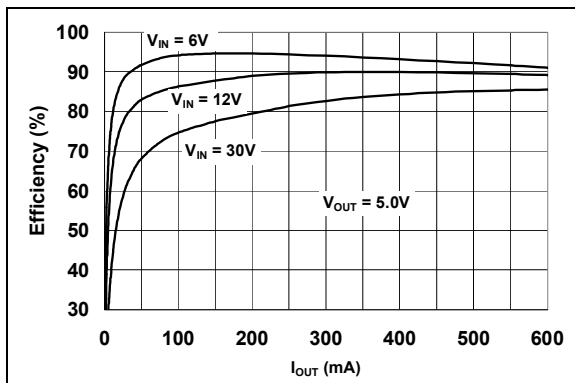

FIGURE 2-3: 5.0V V_{OUT} Efficiency vs. I_{OUT} .

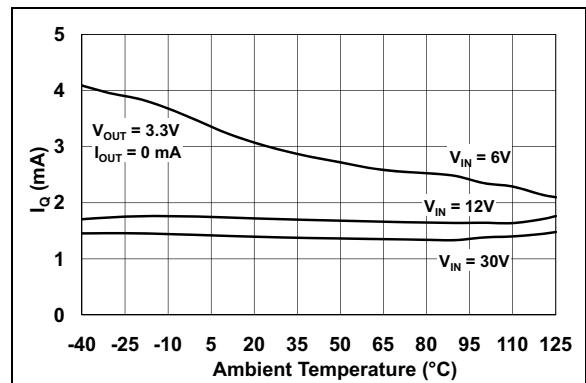

FIGURE 2-6: Input Quiescent Current vs. Temperature.

MCP16301

Note: Unless otherwise indicated, $V_{IN} = EN = 12V$, $C_{OUT} = C_{IN} = 2 \times 10 \mu F$, $L = 15 \mu H$, $V_{OUT} = 3.3V$, $I_{LOAD} = 200 mA$, $T_A = +25^\circ C$.

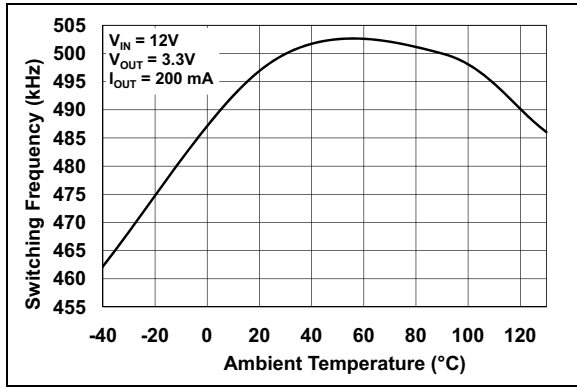

FIGURE 2-7: Switching Frequency vs. Temperature; $V_{OUT} = 3.3V$.

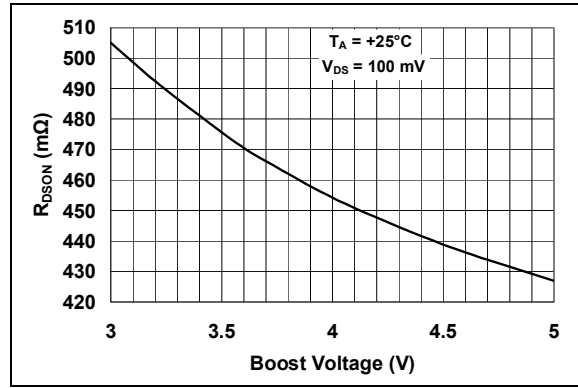

FIGURE 2-10: Switch $R_{DS(on)}$ vs. V_{BOOST} .

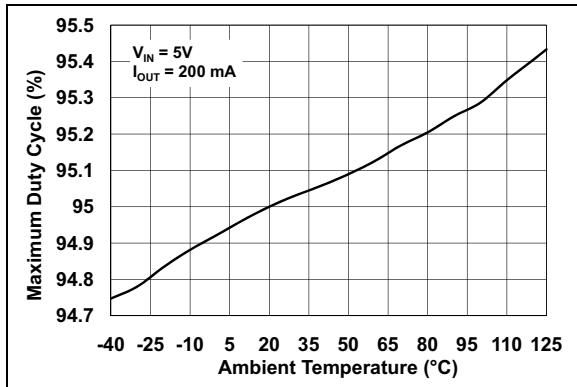

FIGURE 2-8: Maximum Duty Cycle vs. Ambient Temperature; $V_{OUT} = 5.0V$.

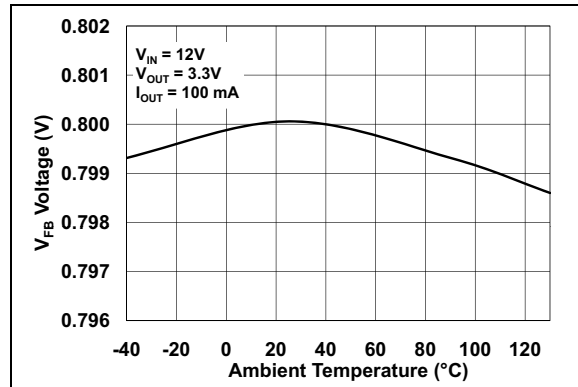

FIGURE 2-11: V_{FB} vs. Temperature; $V_{OUT} = 3.3V$.

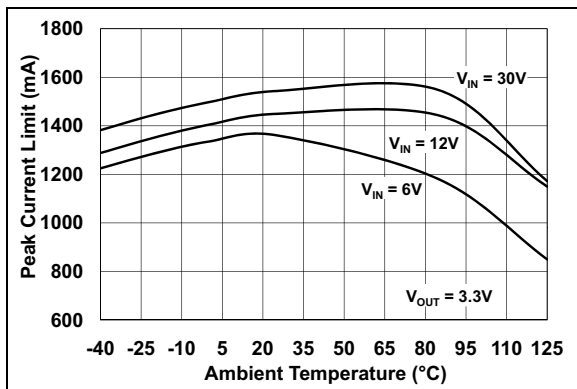

FIGURE 2-9: Peak Current Limit vs. Temperature; $V_{OUT} = 3.3V$.

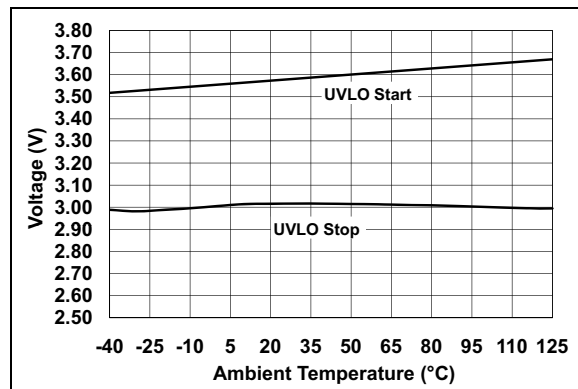

FIGURE 2-12: Under Voltage Lockout vs. Temperature.

Note: Unless otherwise indicated, $V_{IN} = EN = 12V$, $C_{OUT} = C_{IN} = 2 \times 10 \mu F$, $L = 15 \mu H$, $V_{OUT} = 3.3V$, $I_{LOAD} = 200 \text{ mA}$, $T_A = +25^\circ C$.

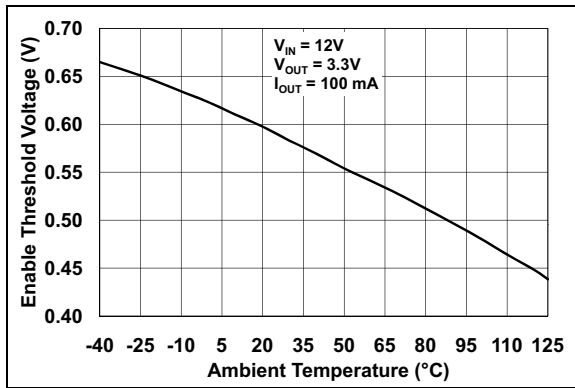

FIGURE 2-13: EN Threshold Voltage vs. Temperature.

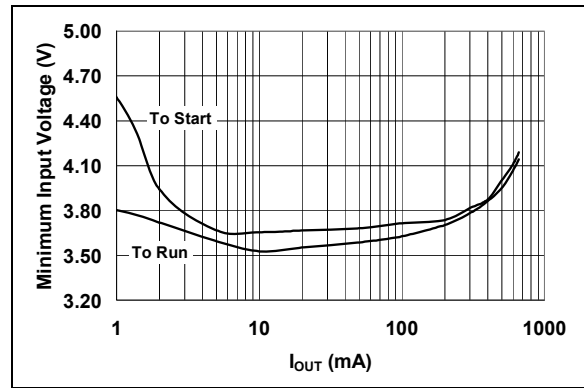

FIGURE 2-16: Typical Minimum Input Voltage vs. Output Current.

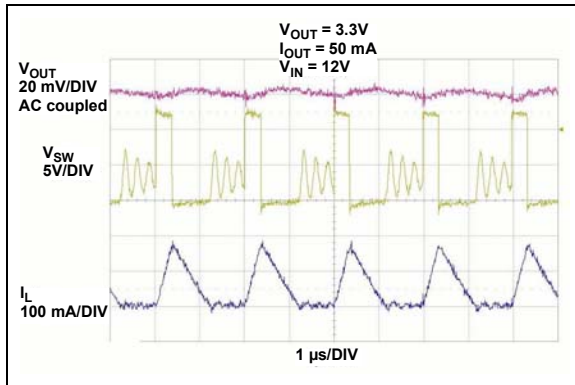

FIGURE 2-14: Light Load Switching Waveforms.

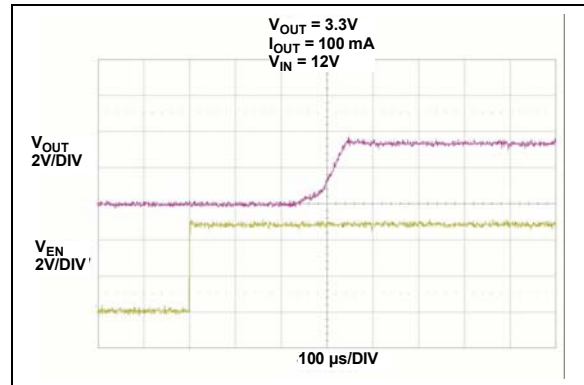

FIGURE 2-17: Startup From Enable.

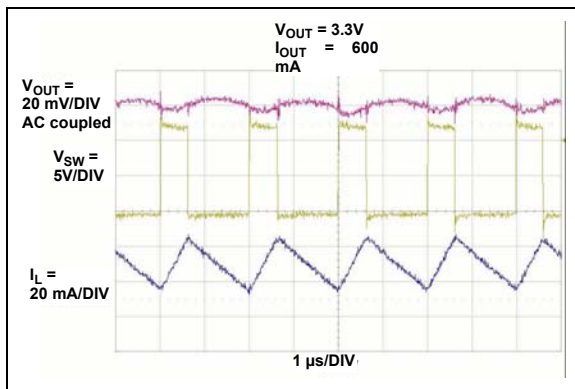

FIGURE 2-15: Heavy Load Switching Waveforms.

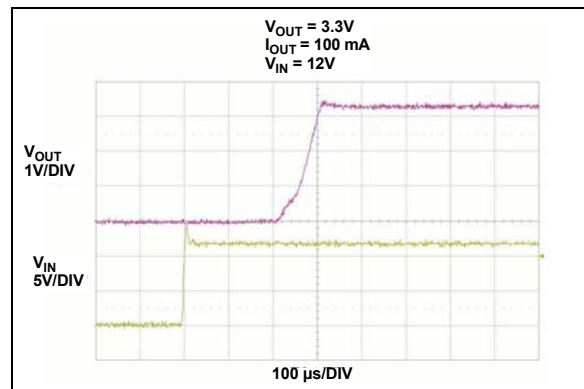

FIGURE 2-18: Startup From V_{IN} .

MCP16301

Note: Unless otherwise indicated, $V_{IN} = EN = 12V$, $C_{OUT} = C_{IN} = 2 \times 10 \mu F$, $L = 15 \mu H$, $V_{OUT} = 3.3V$, $I_{LOAD} = 200 \text{ mA}$, $T_A = +25^\circ C$.

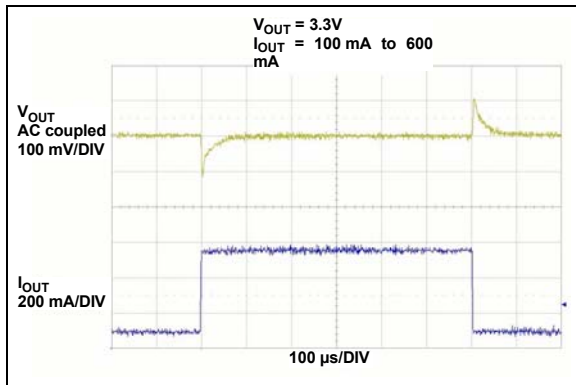

FIGURE 2-19: Load Transient Response.

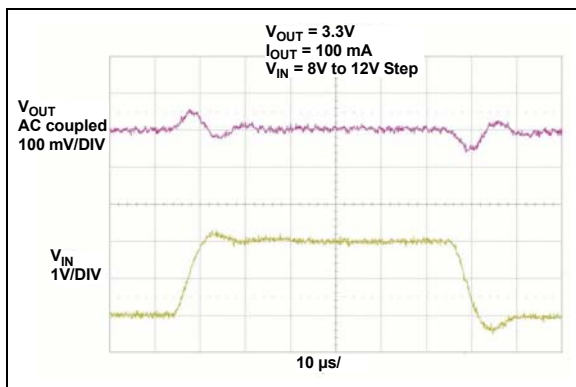

FIGURE 2-20: Line Transient Response.

3.0 PIN DESCRIPTIONS

The descriptions of the pins are listed in [Table 3-1](#).

TABLE 3-1: PIN FUNCTION TABLE

MCP16301 SOT-23	Symbol	Description
1	BOOST	Boost voltage that drives the internal NMOS control switch. A bootstrap capacitor is connected between the BOOST and SW pins.
2	GND	Ground Pin
3	V _{FB}	Output voltage feedback pin. Connect V _{FB} to an external resistor divider to set the output voltage.
4	EN	Enable pin. Logic high enables the operation. Do not allow this pin to float.
5	V _{IN}	Input supply voltage pin for power and internal biasing.
6	SW	Output switch node, connects to the inductor, freewheeling diode and the bootstrap capacitor.

3.1 Boost Pin (BOOST)

The high side of the floating supply used to turn the integrated N-Channel MOSFET on and off is connected to the boost pin.

3.2 Ground Pin (GND)

The ground or return pin is used for circuit ground connection. The length of the trace from the input cap return, output cap return and GND pin should be made as short as possible to minimize the noise on the GND pin.

3.3 Feedback Voltage Pin (V_{FB})

The V_{FB} pin is used to provide output voltage regulation by using a resistor divider. The V_{FB} voltage will be 0.800V typical with the output voltage in regulation.

3.4 Enable Pin (EN)

The EN pin is a logic-level input used to enable or disable the device switching, and lower the quiescent current while disabled. A logic high (> 1.4V) will enable the regulator output. A logic low (<0.4V) will ensure that the regulator is disabled.

3.5 Power Supply Input Voltage Pin (V_{IN})

Connect the input voltage source to V_{IN}. The input source should be decoupled to GND with a 4.7 μF - 20 μF capacitor, depending on the impedance of the source and output current. The input capacitor provides AC current for the power switch and a stable voltage source for the internal device power. This capacitor should be connected as close as possible to the V_{IN} and GND pins. For lighter load applications, a 1 μF X7R (or X5R, for limited temperature range, -40 to +85°C) ceramic capacitor can be used.

3.6 Switch Pin (SW)

The Switch Node pin is connected internally to the N-Channel switch, and externally to the SW node consisting of the inductor and Schottky diode. The SW node can rise very fast, as a result of the internal switch turning on. The external Schottky diode should be connected close to the SW node and GND.

MCP16301

NOTES:

4.0 DETAILED DESCRIPTION

4.1 Device Overview

The MCP16301 is a high-input voltage step-down regulator, capable of supplying 600 mA to a regulated output voltage from 2.0V to 15V. Internally, the trimmed 500 kHz oscillator provides a fixed frequency, while the Peak Current Mode Control architecture varies the duty cycle for output voltage regulation. An internal floating driver is used to turn the high-side integrated N-Channel MOSFET on and off. The power for this driver is derived from an external boost capacitor whose energy is supplied from a fixed voltage ranging between 3.0V and 5.5V, typically the input or output voltage of the converter. For applications with an output voltage outside of this range, 12V for example, the boost capacitor bias can be derived from the output using a simple Zener diode regulator.

4.1.1 INTERNAL REFERENCE VOLTAGE

$$V_{REF}$$

An integrated precise 0.8V reference combined with an external resistor divider sets the desired converter output voltage. The resistor divider range can vary without affecting the control system gain. High-value resistors consume less current, but are more susceptible to noise.

4.1.2 INTERNAL COMPENSATION

All control system components necessary for stable operation over the entire device operating range are integrated, including the error amplifier and inductor current slope compensation. To add the proper amount of slope compensation, the inductor value changes along with the output voltage (see [Table 5-1](#)).

4.1.3 EXTERNAL COMPONENTS

External components consist of:

- input capacitor
- output filter (Inductor and Capacitor)
- freewheeling diode
- boost capacitor
- boost blocking diode
- resistor divider.

The selection of the external inductor, output capacitor, input capacitor and freewheeling diode is dependent upon the output voltage and the maximum output current.

4.1.4 ENABLE INPUT

Enable input, (EN), is used to enable and disable the device. If disabled, the MCP16301 device consumes a minimal current from the input. Once enabled, the internal soft start controls the output voltage rate of rise, preventing high-inrush current and output voltage overshoot.

4.1.5 SOFT START

The internal reference voltage rate of rise is controlled during startup, minimizing the output voltage overshoot and the inrush current.

4.1.6 UNDER VOLTAGE LOCKOUT

An integrated Under Voltage Lockout (UVLO) prevents the converter from starting until the input voltage is high enough for normal operation. The converter will typically start at 3.5V and operate down to 3.0V. Hysteresis is added to prevent starting and stopping during startup, as a result of loading the input voltage source.

4.1.7 OVERTEMPERATURE PROTECTION

Overtemperature protection limits the silicon die temperature to +150°C by turning the converter off. The normal switching resumes at +120°C.

MCP16301

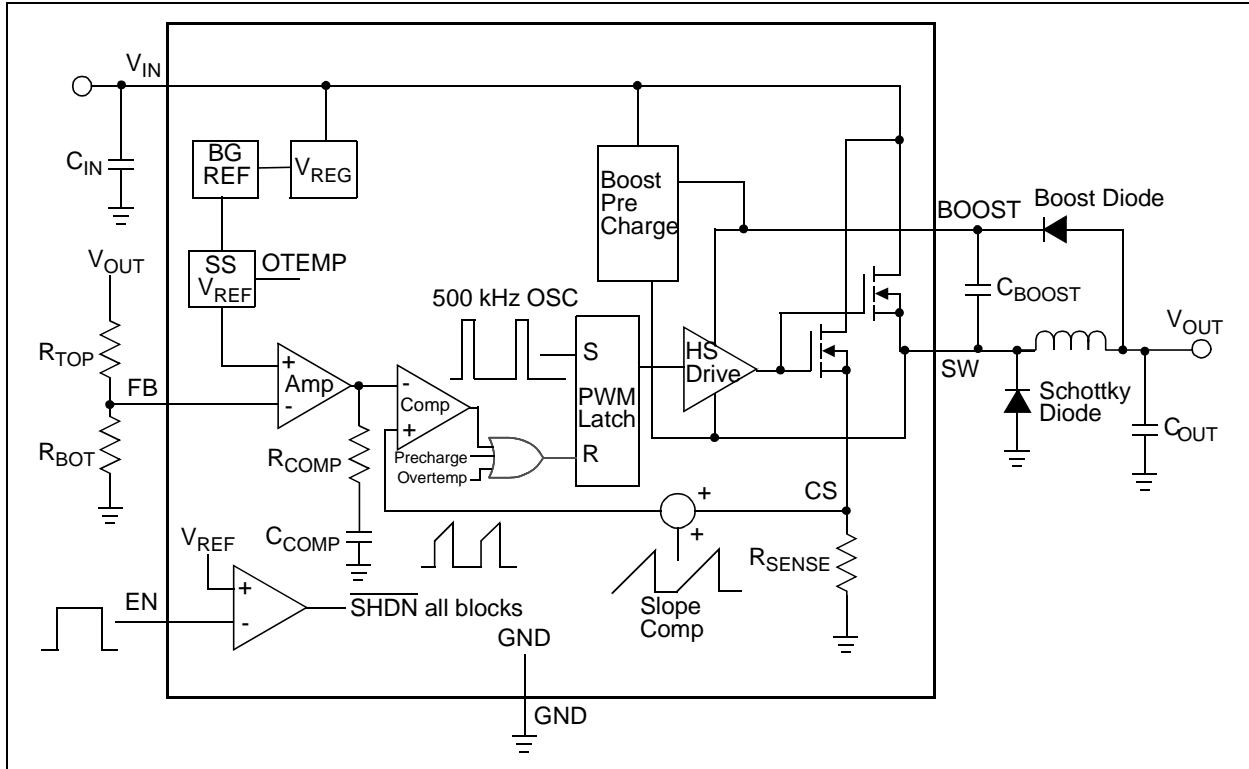

FIGURE 4-1: MCP16301 Block Diagram.

4.2 Functional Description

4.2.1 STEP-DOWN OR BUCK CONVERTER

The MCP16301 is a non-synchronous, step-down or buck converter capable of stepping input voltages ranging from 4V to 30V down to 2.0V to 15V for $V_{IN} > V_{OUT}$.

The integrated high-side switch is used to chop or modulate the input voltage using a controlled duty cycle for output voltage regulation. High efficiency is achieved by using a low resistance switch, low forward drop diode, low equivalent series resistance (ESR), inductor and capacitor. When the switch is turned on, a DC voltage is applied to the inductor ($V_{IN} - V_{OUT}$), resulting in a positive linear ramp of inductor current. When the switch turns off, the applied inductor voltage is equal to $-V_{OUT}$, resulting in a negative linear ramp of inductor current (ignoring the forward drop of the Schottky diode).

For steady-state, continuous inductor current operation, the positive inductor current ramp must equal the negative current ramp in magnitude. While operating in steady state, the switch duty cycle must be equal to the relationship of V_{OUT}/V_{IN} for constant output voltage regulation, under the condition that the inductor current is continuous, or never reaches zero. For discontinuous inductor current operation, the steady-state duty cycle will be less than V_{OUT}/V_{IN} to maintain voltage regulation. The average of the

chopped input voltage or SW node voltage is equal to the output voltage, while the average of the inductor current is equal to the output current.

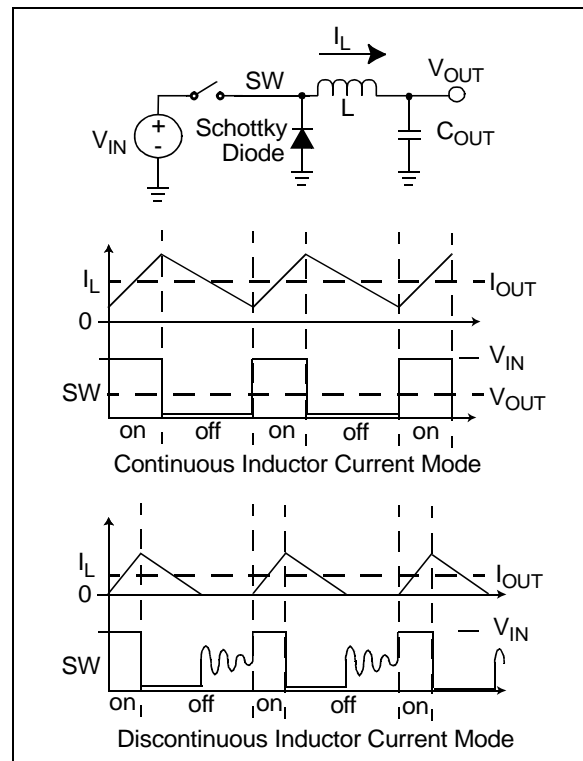

FIGURE 4-2: Step-Down Converter.

4.2.2 PEAK CURRENT MODE CONTROL

The MCP16301 integrates a Peak Current Mode Control architecture, resulting in superior AC regulation while minimizing the number of voltage loop compensation components, and their size, for integration. Peak Current Mode Control takes a small portion of the inductor current, replicates it and compares this replicated current sense signal with the output of the integrated error voltage. In practice, the inductor current and the internal switch current are equal during the switch-on time. By adding this peak current sense to the system control, the step-down power train system is reduced from a 2nd order to a 1st order. This reduces the system complexity and increases its dynamic performance.

For Pulse-Width Modulation (PWM) duty cycles that exceed 50%, the control system can become bimodal where a wide pulse followed by a short pulse repeats instead of the desired fixed pulse width. To prevent this mode of operation, an internal compensating ramp is summed into the current shown in [Figure 4-1](#).

4.2.3 PULSE-WIDTH MODULATION (PWM)

The internal oscillator periodically starts the switching period, which in MCP16301's case occurs every 2 μ s or 500 kHz. With the integrated switch turned on, the inductor current ramps up until the sum of the current sense and slope compensation ramp exceeds the integrated error amplifier output. The error amplifier output slews up or down to increase or decrease the inductor peak current feeding into the output LC filter. If the regulated output voltage is lower than its target, the inverting error amplifier output rises. This results in an increase in the inductor current to correct for errors in the output voltage.

The fixed frequency duty cycle is terminated when the sensed inductor peak current, summed with the internal slope compensation, exceeds the output voltage of the error amplifier. The PWM latch is reset, by turning off the internal switch and preventing it from turning on until the beginning of the next cycle. An overtemperature signal, or boost cap undervoltage, can also reset the PWM latch to asynchronously terminate the cycle.

4.2.4 HIGH SIDE DRIVE

The MCP16301 features an integrated high-side N-Channel MOSFET for high efficiency step-down power conversion. An N-Channel MOSFET is used for its low resistance and size (instead of a P-Channel MOSFET). The N-Channel MOSFET gate must be driven above its source to fully turn on the transistor. A gate-drive voltage above the input is necessary to turn on the high side N-Channel. The high side drive voltage should be between 3.0V and 5.5V. The N-Channel source is connected to the inductor and Schottky diode, or switch node.

When the switch is off, the inductor current flows through the Schottky diode, providing a path to recharge the boost cap from the boost voltage source, typically the output voltage for 3.0V to 5.0V output applications. A boost-blocking diode is used to prevent current flow from the boost cap back into the output during the internal switch-on time. Prior to startup, the boost cap has no stored charge to drive the switch. An internal regulator is used to "pre-charge" the boost cap.

Once pre-charged, the switch is turned on and the inductor current flows. When the switch turns off, the inductor current free-wheels through the Schottky diode, providing a path to recharge the boost cap. Worst case conditions for recharge occur when the switch turns on for a very short duty cycle at light load, limiting the inductor current ramp. In this case, there is a small amount of time for the boost capacitor to recharge. For high input voltages there is enough pre-charge current to replace the boost cap charge. For input voltages above 5.5V typical, the MCP16301 device will regulate the output voltage with no load. After starting, the MCP16301 will regulate the output voltage until the input voltage decreases below 4V. See [Figure 2-16](#) for device range of operation over input voltage, output voltage and load.

4.2.5 ALTERNATIVE BOOST BIAS

For 3.0V to 5.0V output voltage applications, the boost supply is typically the output voltage. For applications with $3.0V < V_{OUT} < 5.0V$, an alternative boost supply can be used.

Alternative boost supplies can be from the input, input derived, output derived or an auxiliary system voltage.

For low voltage output applications with unregulated input voltage, a shunt regulator derived from the input can be used to derive the boost supply. For applications with high output voltage or regulated high input voltage, a series regulator can be used to derive the boost supply.

MCP16301

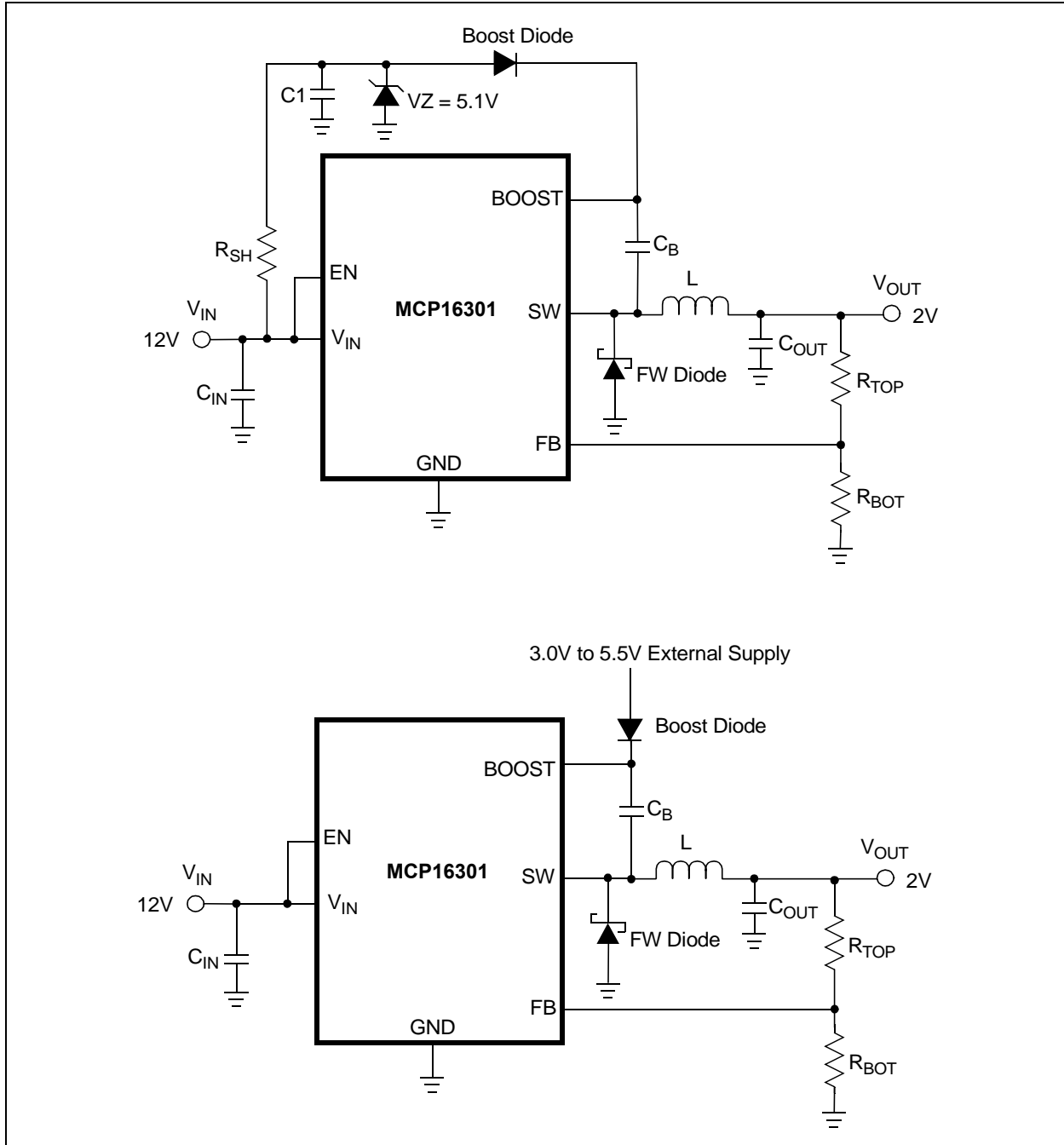

FIGURE 4-3: Shunt and External Boost Supply.

Shunt Boost Supply Regulation is used for low output voltage converters operating from a wide ranging input source. A regulated 3.0V to 5.5V supply is needed to provide high side-drive bias. The shunt uses a Zener diode to clamp the voltage within the 3.0V to 5.5V range using the resistance shown in [Figure 4-3](#).

To calculate the shunt resistance, the boost drive current can be estimated using [Equation 4-1](#).

I_{BOOST_TYP} for 3.3V Boost Supply = 0.6 mA

I_{BOOST_TYP} for 5.0V Boost Supply = 0.8 mA.

EQUATION 4-1: BOOST CURRENT

$$I_{BOOST} = I_{BOOST_TYP} \times 1.5mA$$

To calculate the shunt resistance, the maximum I_{BOOST} and I_Z current are used at the minimum input voltage (Equation 4-2).

V_Z and I_Z can be found on the Zener diode manufacturer's data sheet. Typical $I_Z = 1\text{ mA}$.

EQUATION 4-2: SHUNT RESISTANCE

$$R_{SH} = \frac{V_{INMIN} - V_Z}{I_{Boost} + I_Z}$$

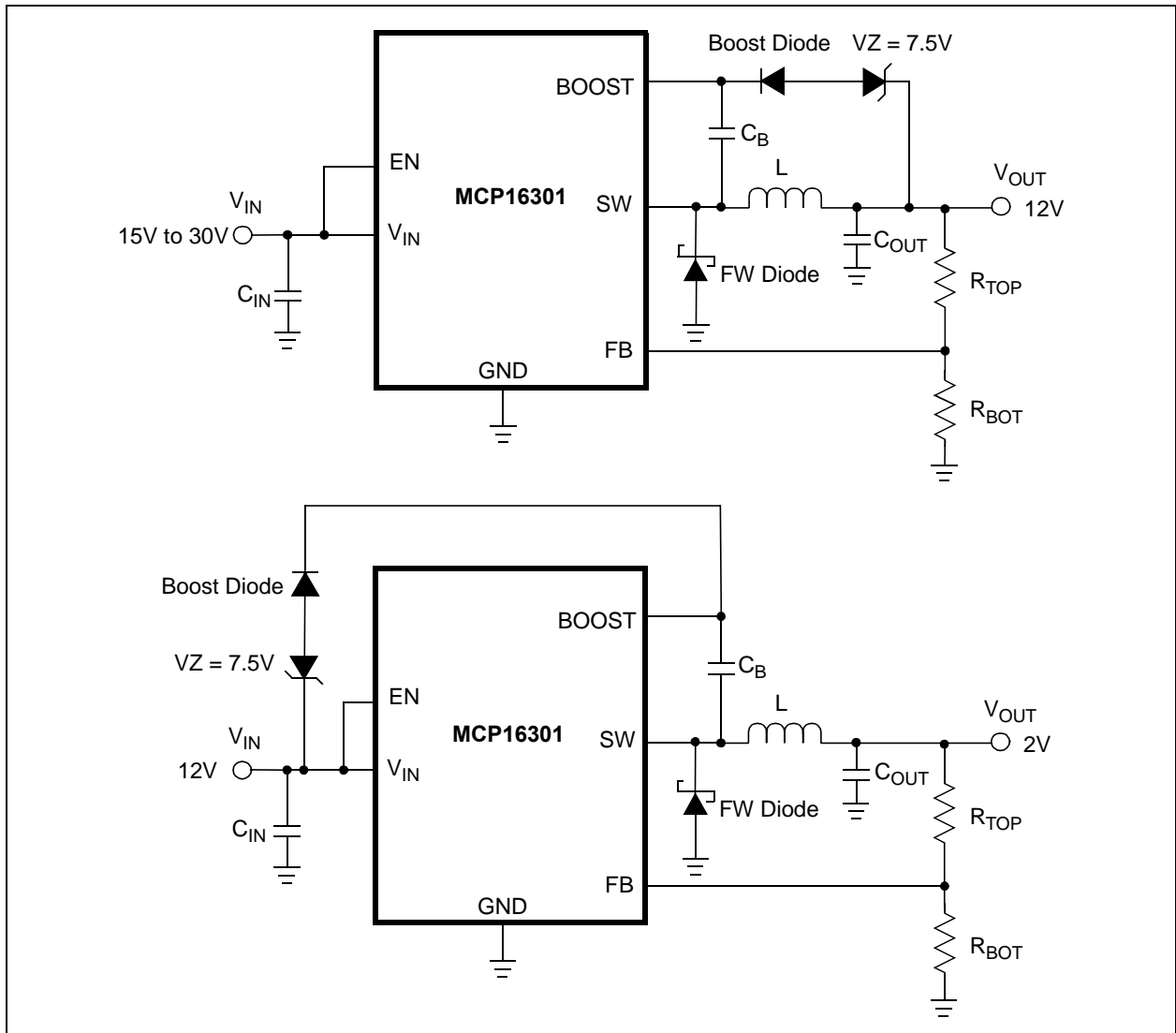

FIGURE 4-4: Series Regulator Boost Supply.

Series regulator applications use a Zener diode to drop the excess voltage. The series regulator bias source can be input or output voltage derived, as shown in Figure 4-4. The boost supply must remain between 3.0V and 5.5V at all times for proper circuit operation.

MCP16301

NOTES:

5.0 APPLICATION INFORMATION

5.1 Typical Applications

The MCP16301 step-down converter operates over a wide input voltage range, up to 30V maximum. Typical applications include generating a bias or V_{DD} voltage for the PIC[®] microcontroller product line, digital control system bias supply for AC-DC converters, 24V industrial input and similar applications.

5.2 Adjustable Output Voltage Calculations

To calculate the resistor divider values for the MCP16301, Equation 5-1 can be used. R_{TOP} is connected to V_{OUT} , R_{BOT} is connected to GND and both are connected to the V_{FB} input pin.

EQUATION 5-1:

$$R_{TOP} = R_{BOT} \times \left(\frac{V_{OUT}}{V_{FB}} - 1 \right)$$

EXAMPLE 5-1:

$$\begin{aligned} V_{OUT} &= 3.3V \\ V_{FB} &= 0.8V \\ R_{BOT} &= 10 \text{ k}\Omega \\ R_{TOP} &= 31.25 \text{ k}\Omega \text{ (Standard Value = 31.2 k}\Omega\text{)} \\ V_{OUT} &= 3.3V \end{aligned}$$

EXAMPLE 5-2:

$$\begin{aligned} V_{OUT} &= 5.0V \\ V_{FB} &= 0.8V \\ R_{BOT} &= 10 \text{ k}\Omega \\ R_{TOP} &= 52.5 \text{ k}\Omega \text{ (Standard Value = 52.3 k}\Omega\text{)} \\ V_{OUT} &= 4.98V \end{aligned}$$

The transconductance error amplifier gain is controlled by its internal impedance. The external divider resistors have no effect on system gain, so a wide range of values can be used. A 10 k Ω resistor is recommended as a good trade-off for quiescent current and noise immunity.

5.3 General Design Equations

The step down converter duty cycle can be estimated using Equation 5-2, while operating in Continuous Inductor Current mode. This equation also counts the forward drop of the freewheeling diode and internal N-Channel MOSFET switch voltage drop. As the load current increases, the switch voltage drop and diode voltage drop increase, requiring a larger PWM duty cycle to maintain the output voltage regulation. Switch voltage drop is estimated by multiplying the switch current times the switch resistance or $R_{DS(ON)}$.

EQUATION 5-2: CONTINUOUS INDUCTOR CURRENT DUTY CYCLE

$$D = \frac{(V_{OUT} + V_{Diode})}{(V_{IN} - (I_{SW} \times R_{DS(ON)})}$$

The MCP16301 device features an integrated slope compensation to prevent the bimodal operation of the PWM duty cycle. Internally, half of the inductor current down slope is summed with the internal current sense signal. For the proper amount of slope compensation, it is recommended to keep the inductor down-slope current constant by varying the inductance with V_{OUT} , where $K = 0.22V/\mu H$.

EQUATION 5-3:

$$K = V_{OUT}/L$$

For $V_{OUT} = 3.3V$, an inductance of 15 μH is recommended.

TABLE 5-1: RECOMMENDED INDUCTOR VALUES

V_{OUT}	K	$L_{STANDARD}$
2.0V	0.20	10 μH
3.3V	0.22	15 μH
5.0V	0.23	22 μH
12V	0.21	56 μH
15V	0.22	68 μH

MCP16301

5.4 Input Capacitor Selection

The step-down converter input capacitor must filter the high input ripple current, as a result of pulsing or chopping the input voltage. The MCP16301 input voltage pin is used to supply voltage for the power train and as a source for internal bias. A low equivalent series resistance (ESR), preferably a ceramic capacitor, is recommended. The necessary capacitance is dependent upon the maximum load current and source impedance. Three capacitor parameters to keep in mind are the voltage rating, equivalent series resistance and the temperature rating. For wide temperature range applications, a multi-layer X7R dielectric is mandatory, while for applications with limited temperature range, a multi-layer X5R dielectric is acceptable. Typically, input capacitance between 4.7 μF and 10 μF is sufficient for most applications. For applications with 100 mA to 200 mA load, a 1 μF X7R capacitor can be used, depending on the input source and its impedance.

The input capacitor voltage rating should be a minimum of V_{IN} plus margin. Table 5-2 contains the recommended range for the input capacitor value.

5.5 Output Capacitor Selection

The output capacitor helps in providing a stable output voltage during sudden load transients, and reduces the output voltage ripple. As with the input capacitor, X5R and X7R ceramic capacitors are well suited for this application.

The MCP16301 is internally compensated, so the output capacitance range is limited. See Table 5-2 for the recommended output capacitor range.

The amount and type of output capacitance and equivalent series resistance will have a significant effect on the output ripple voltage and system stability. The range of the output capacitance is limited due to the integrated compensation of the MCP16301.

The output voltage capacitor voltage rating should be a minimum of V_{OUT} , plus margin.

Table 5-2 contains the recommended range for the input and output capacitor value:

TABLE 5-2: CAPACITOR VALUE RANGE

Parameter	Min	Max
C_{IN}	2.2 μF	none
C_{OUT}	20 μF	none

5.6 Inductor Selection

The MCP16301 is designed to be used with small surface mount inductors. Several specifications should be considered prior to selecting an inductor. To optimize system performance, the inductance value is determined by the output voltage (Table 5-1) so the inductor ripple current is somewhat constant over the output voltage range.

EQUATION 5-4: INDUCTOR RIPPLE CURRENT

$$\Delta I_L = \frac{V_L}{L} \times t_{\text{ON}}$$

EXAMPLE 5-3:

$$\begin{aligned} V_{\text{IN}} &= 12\text{V} \\ V_{\text{OUT}} &= 3.3\text{V} \\ I_{\text{OUT}} &= 600\text{ mA} \end{aligned}$$

EQUATION 5-5: INDUCTOR PEAK CURRENT

$$I_{\text{LPK}} = \frac{\Delta I_L}{2} + I_{\text{OUT}}$$

$$\begin{aligned} \text{Inductor ripple current} &= 319\text{ mA} \\ \text{Inductor peak current} &= 760\text{ mA} \end{aligned}$$

An inductor saturation rating minimum of 760 mA is recommended. Low ESR inductors result in higher system efficiency. A trade-off between size, cost and efficiency is made to achieve the desired results.

TABLE 5-3: MCP16301 RECOMMENDED 3.3V INDUCTORS

Part Number	Value (µH)	DCR (Ω)	I _{SAT} (A)	Size WxLxH (mm)
Coilcraft®				
ME3220	15	0.52	0.90	3.2x2.5x1.0
LPS4414	15	0.440	0.92	4.3x4.3x1.4
LPS6235	15	0.125	2.00	6.0x6.0x3.5
MSS6132	15	0.135	1.56	6.1x6.1x3.2
MSS7341	15	0.057	1.78	7.3x7.3x4.1
ME3220	15	0.520	0.8	2.8x3.2x2.0
XFL2006	15	2.02	0.25	2.0x2.0x0.6
LPS3015	15	0.700	0.61	3.0x3.0x1.4
Würth Elektronik®				
744028	15	0.750	0.35	2.8x2.8x1.1
744029	15	0.600	0.42	2.8x2.8x1.35
744025	15	0.400	0.900	2.8x2.8x2.8
744031	15	0.255	0.450	3.8x3.8x1.65
744042	15	0.175	0.75	4.8x4.8x1.8
Coiltronics®				
SD12	15	0.48	0.692	5.2x5.2x1.2
SD18	15	0.266	0.831	5.2x5.2x1.8
SD20	15	0.193	0.718	5.2x5.2x2.0
SD3118	15	0.51	0.75	3.2x3.2x1.8
SD52	15	0.189	0.88	5.2x5.5x2.0
Sumida®				
CDPH4D19F	15	0.075	0.66	5.2x5.2x2.0
CDRH2D09C	15	0.52	0.24	3.2x3.2x1.0
CDRH2D162D	15	0.198	0.35	3.2x3.2x1.8
CDRH3D161H	15	0.328	0.65	4.0x4.0x1.8
TDK - EPC®				
VLF3012A	15	0.54	0.41	2.8x2.6x1.2
VLF30251	15	0.5	0.47	2.5x3.0x1.2
VLF4012A	15	0.46	0.63	3.5x3.7x1.2
VLF5014A	15	0.28	0.97	4.5x4.7x1.4
B82462G4332M	15	0.097	1.05	6x6x2.2

5.7 Freewheeling Diode

The freewheeling diode creates a path for inductor current flow after the internal switch is turned off. The average diode current is dependent upon output load current at duty cycle (D). The efficiency of the converter is a function of the forward drop and speed of the freewheeling diode. A low forward drop Schottky diode is recommended. The current rating and voltage rating of the diode is application dependent. The diode voltage rating should be a minimum of V_{IN}, plus margin. For example, a diode rating of 40V should be used for an application with a maximum input of 30V. The average diode current can be calculated using [Equation 5-6](#).

EQUATION 5-6: DIODE AVERAGE CURRENT

$$I_{D1AVG} = (1 - D) \times I_{OUT}$$

EXAMPLE 5-4:

I _{OUT}	=	0.5A
V _{IN}	=	15V
V _{OUT}	=	5V
D	=	5/15
I _{D1AVG}	=	333 mA

A 0.5A to 1A diode is recommended.

TABLE 5-4: FREEWHEELING DIODES

App	Manufacturer	Part Number	Rating
12 V _{IN} 600 mA	Diodes Inc.	DFLS120L-7	20V, 1A
24 V _{IN} 100 mA	Diodes Inc.	B0540Ws-7	40V, 0.5A
18 V _{IN} 600 mA	Diodes Inc.	B130L-13-F	30V, 1A

5.8 Boost Diode

The boost diode is used to provide a charging path from the low voltage gate drive source, while the switch node is low. The boost diode blocks the high voltage of the switch node from feeding back into the output voltage when the switch is turned on, forcing the switch node high.

A standard 1N4148 ultra-fast diode is recommended for its recovery speed, high voltage blocking capability, availability and cost. The voltage rating required for the boost diode is V_{IN}.

For low boost voltage applications, a small Schottky diode with the appropriately rated voltage can be used to lower the forward drop, increasing the boost supply for gate drive.

MCP16301

5.9 Boost Capacitor

The boost capacitor is used to supply current for the internal high side drive circuitry that is above the input voltage. The boost capacitor must store enough energy to completely drive the high side switch on and off. A 0.1 μF X5R or X7R capacitor is recommended for all applications. The boost capacitor maximum voltage is 5.5V, so a 6.3V or 10V rated capacitor is recommended.

5.10 Thermal Calculations

The MCP16301 is available in a SOT-23-6 package. By calculating the power dissipation and applying the package thermal resistance (θ_{JA}), the junction temperature is estimated. The maximum continuous junction temperature rating for the MCP16301 is +125°C.

To quickly estimate the internal power dissipation for the switching step-down regulator, an empirical calculation using measured efficiency can be used. Given the measured efficiency, the internal power dissipation is estimated by Equation 5-7. This power dissipation includes all internal and external component losses. For a quick internal estimate, subtract the estimated Schottky diode loss and inductor ESR loss from the P_{DIS} calculation in Equation 5-7.

EQUATION 5-7: TOTAL POWER DISSIPATION ESTIMATE

$$\left(\frac{V_{OUT} \times I_{OUT}}{\text{Efficiency}}\right) - (V_{OUT} \times I_{OUT}) = P_{Dis}$$

The difference between the first term, input power, and the second term, power delivered, is the total system power dissipation. The freewheeling Schottky diode losses are determined by calculating the average diode current and multiplying by the diode forward drop. The inductor losses are estimated by $P_L = I_{OUT}^2 \times L_{ESR}$.

EQUATION 5-8: DIODE POWER DISSIPATION ESTIMATE

$$P_{Diode} = V_F \times ((1 - D) \times I_{OUT})$$

EXAMPLE 5-5:

V_{IN}	=	10V
V_{OUT}	=	5.0V
I_{OUT}	=	0.4A
Efficiency	=	90%
Total System Dissipation	=	222 mW
L_{ESR}	=	0.15 Ω
P_L	=	24 mW
Diode VF	=	0.50
D	=	50%
P_{Diode}	=	125 mW

MCP16301 internal power dissipation estimate:

$$P_{DIS} - P_L - P_{DIODE} = 73 \text{ mW}$$

θ_{JA}	=	198°C/W
Estimated Junction Temperature Rise	=	+14.5°C

5.11 PCB Layout Information

Good printed circuit board layout techniques are important to any switching circuitry, and switching power supplies are no different. When wiring the switching high-current paths, short and wide traces should be used. Therefore, it is important that the input and output capacitors be placed as close as possible to the MCP16301 to minimize the loop area.

The feedback resistors and feedback signal should be routed away from the switching node and the switching current loop. When possible, ground planes and traces should be used to help shield the feedback signal and minimize noise and magnetic interference.

A good MCP16301 layout starts with C_{IN} placement. C_{IN} supplies current to the input of the circuit when the switch is turned on. In addition to supplying high-frequency switch current, C_{IN} also provides a stable voltage source for the internal MCP16301 circuitry. Unstable PWM operation can result if there are excessive transients or ringing on the V_{IN} pin of the MCP16301 device. In Figure 5-1, C_{IN} is placed close to pin 5. A ground plane on the bottom of the board provides a low resistive and inductive path for the return current. The next priority in placement is the freewheeling current loop formed by D1, C_{OUT} and L, while strategically placing C_{OUT} return close to C_{IN} return. Next, C_B and D_B should be placed between the boost pin and the switch node pin SW. This leaves space close to the MCP16301 V_{FB} pin to place R_{TOP} and R_{BOT} . R_{TOP} and R_{BOT} are routed away from the Switch node so noise is not coupled into the high-impedance V_{FB} input.

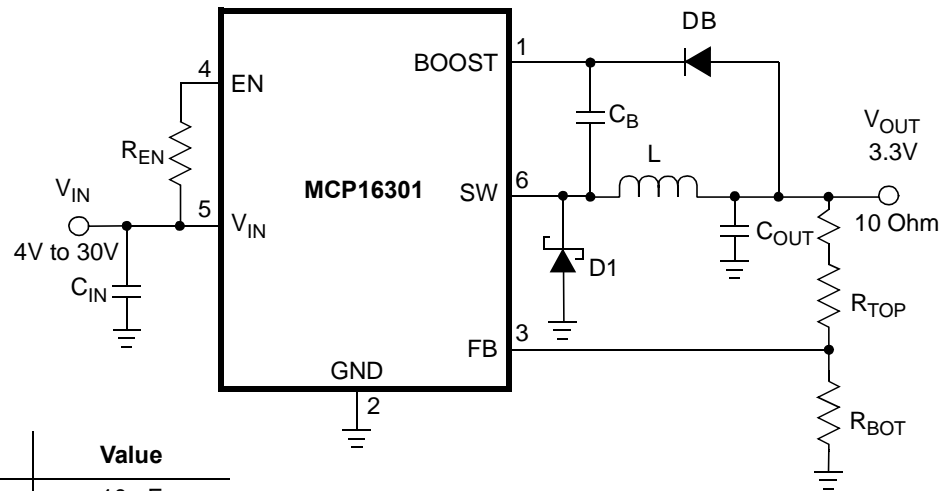
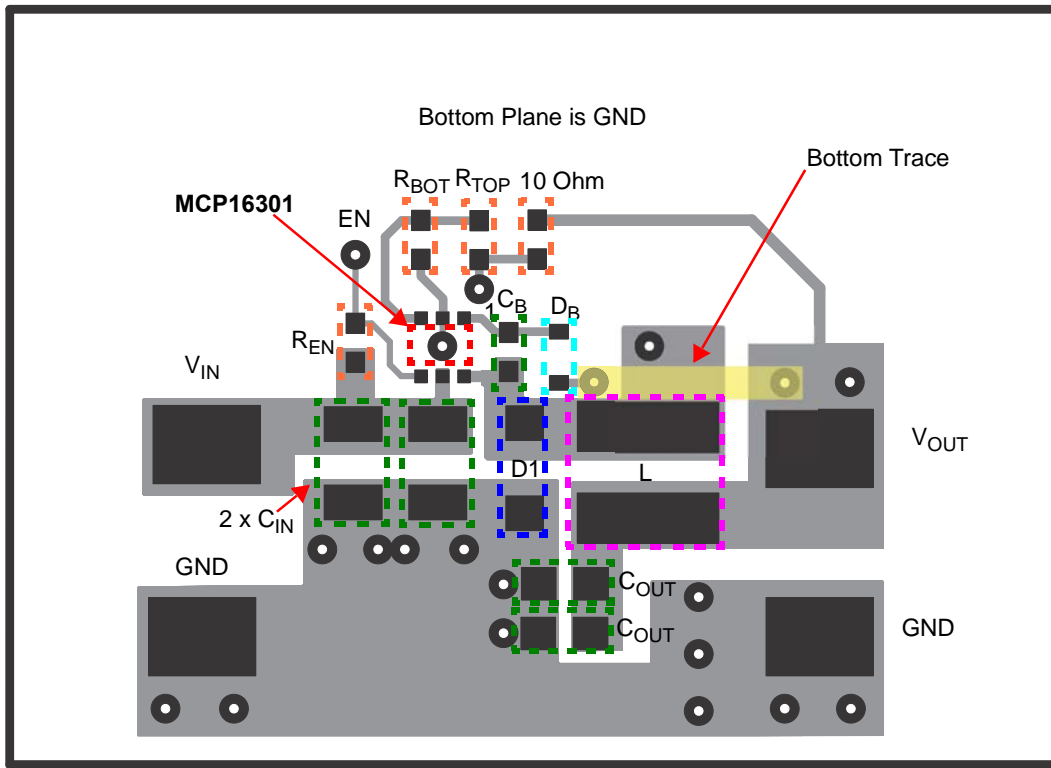

Component	Value
C_{IN}	10 μ F
C_{OUT}	2 x 10 μ F
L	15 μ H
R_{TOP}	31.2 k Ω
R_{BOT}	10 k Ω
D1	B140
D _B	1N4148
C _B	100 nF

***Note:** 10 Ohm resistor is used with network analyzer, to measure system gain and phase.

FIGURE 5-1: MCP16301 SOT-23-6 Recommended Layout, 600 mA Design.

MCP16301

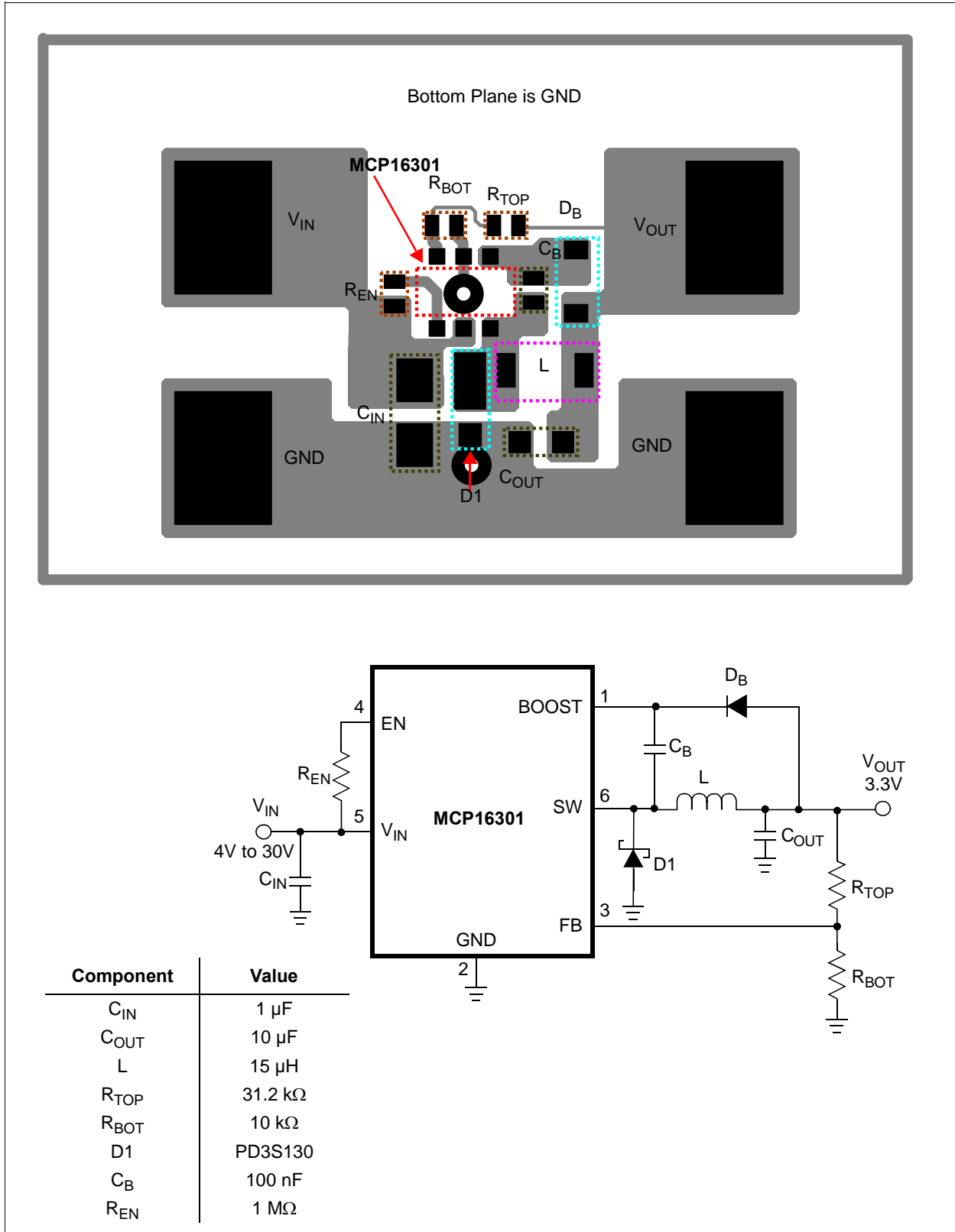

FIGURE 5-2: MCP16301 SOT-23-6 D^2 Recommended Layout, 200 mA Design.

6.0 TYPICAL APPLICATION CIRCUITS

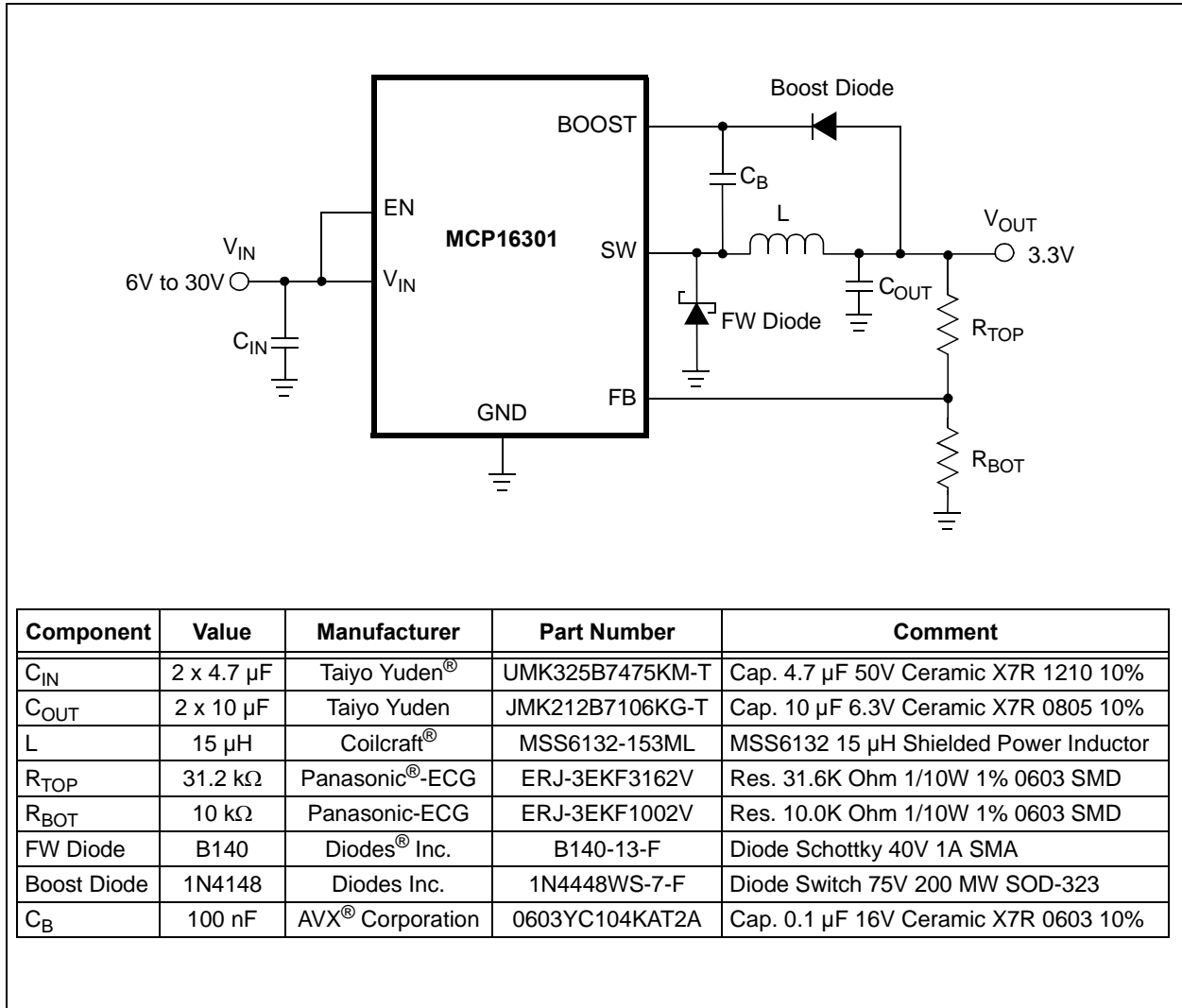

FIGURE 6-1: Typical Application 30V V_{IN} to 3.3V V_{OUT} .

MCP16301

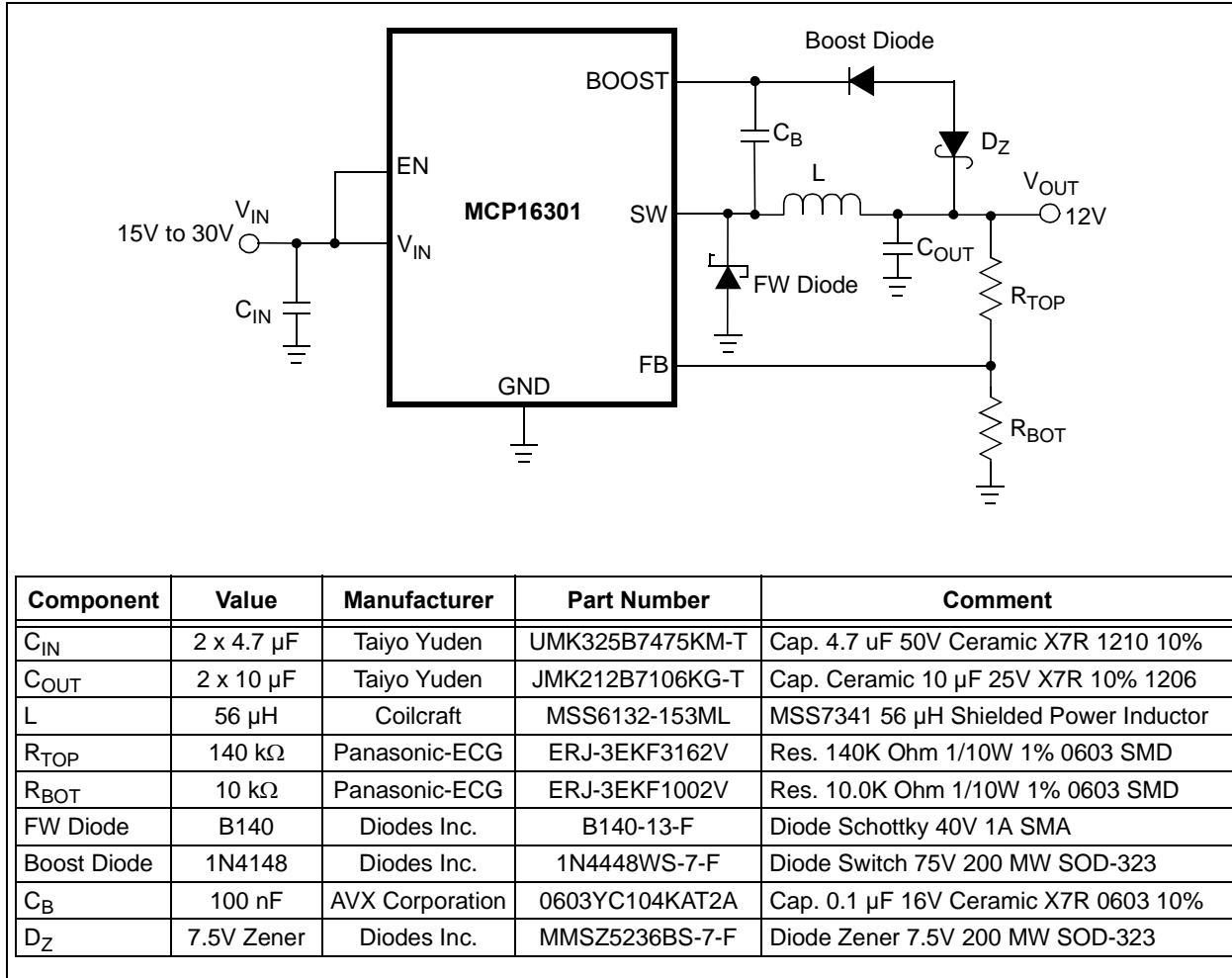

FIGURE 6-2: Typical Application 15V – 30V Input; 12V Output.

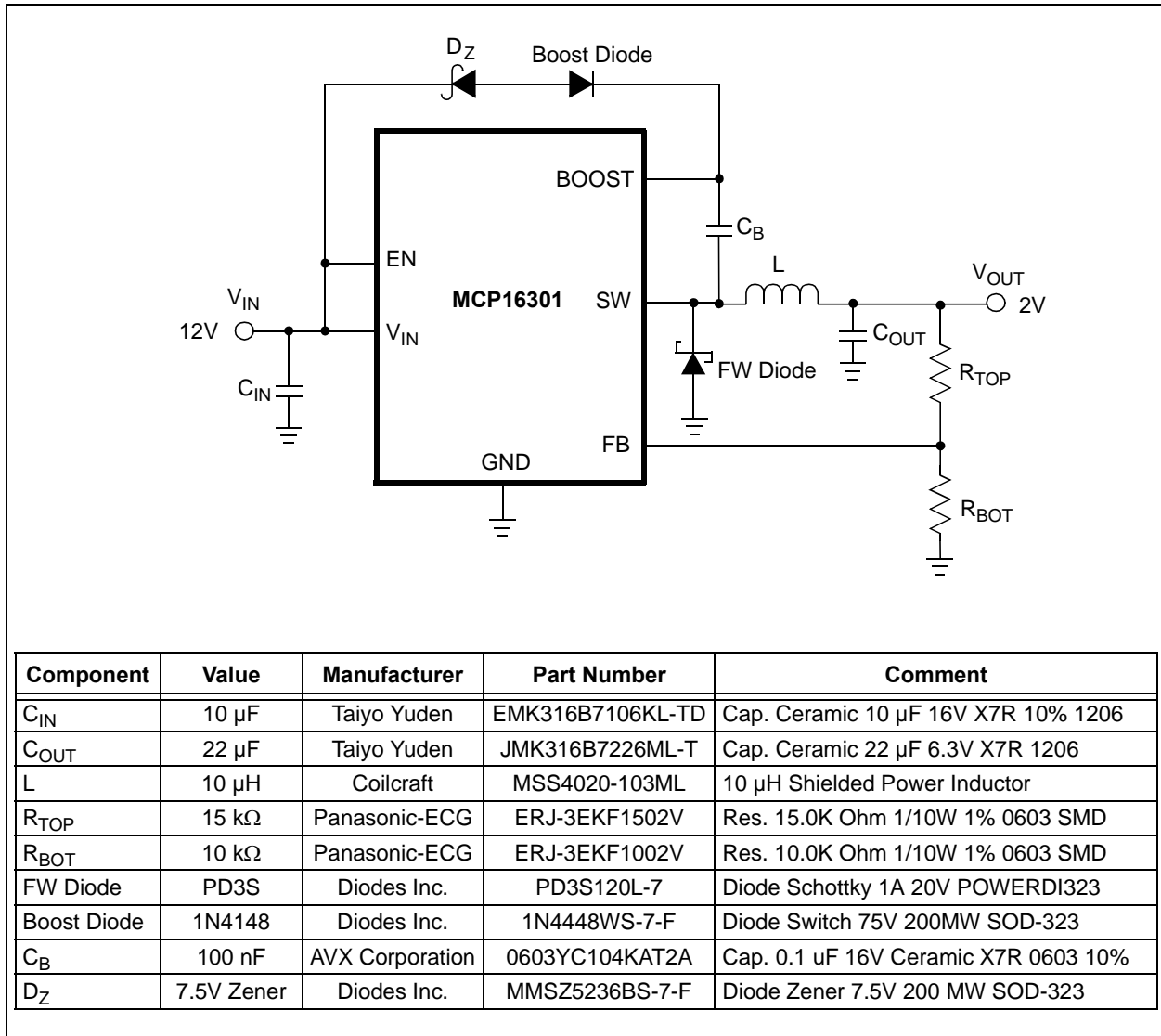

FIGURE 6-3: Typical Application 12V Input; 2V Output at 600 mA.

MCP16301

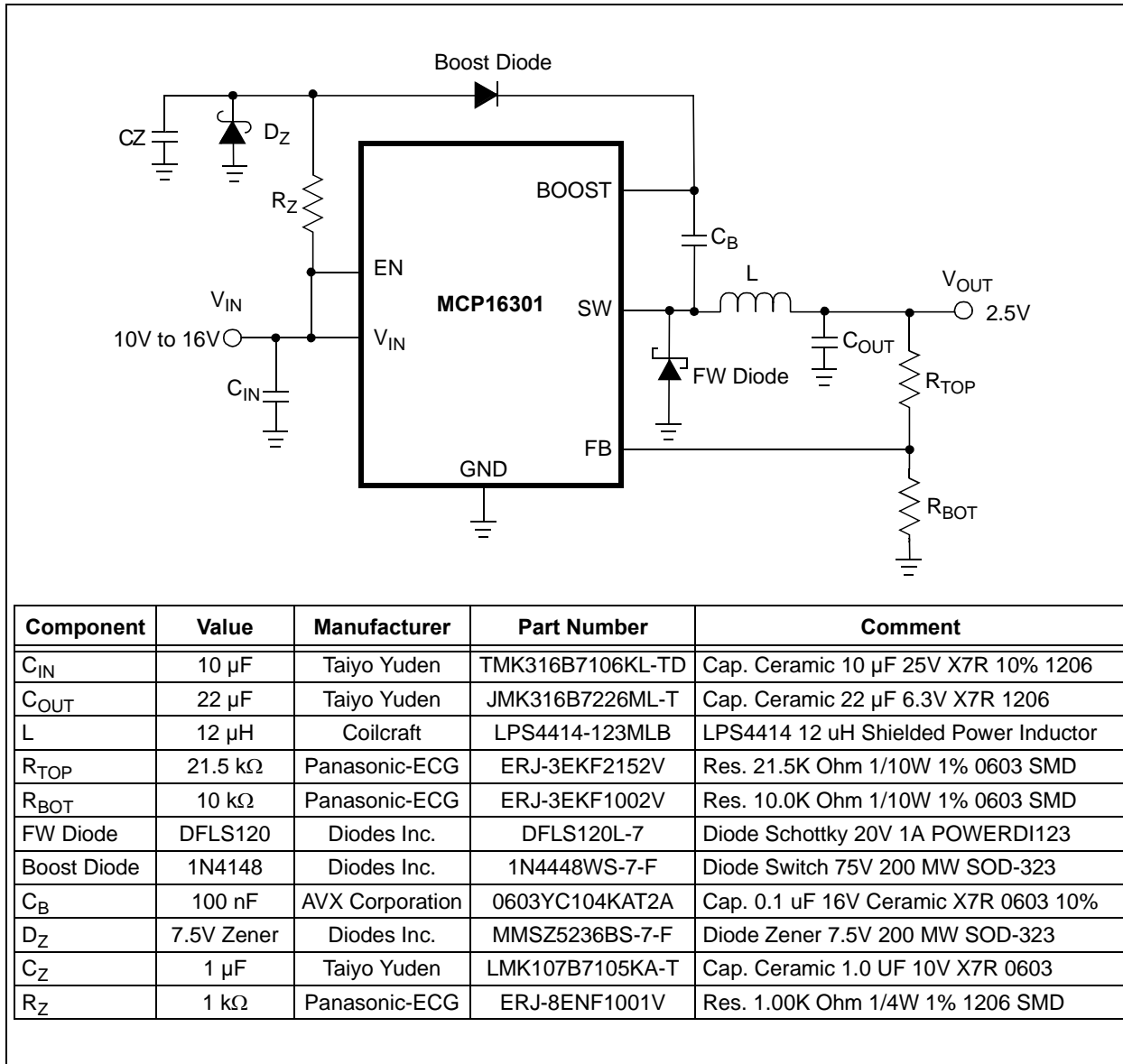

FIGURE 6-4: Typical Application 10V to 16V V_{IN} to 2.5V V_{OUT} .

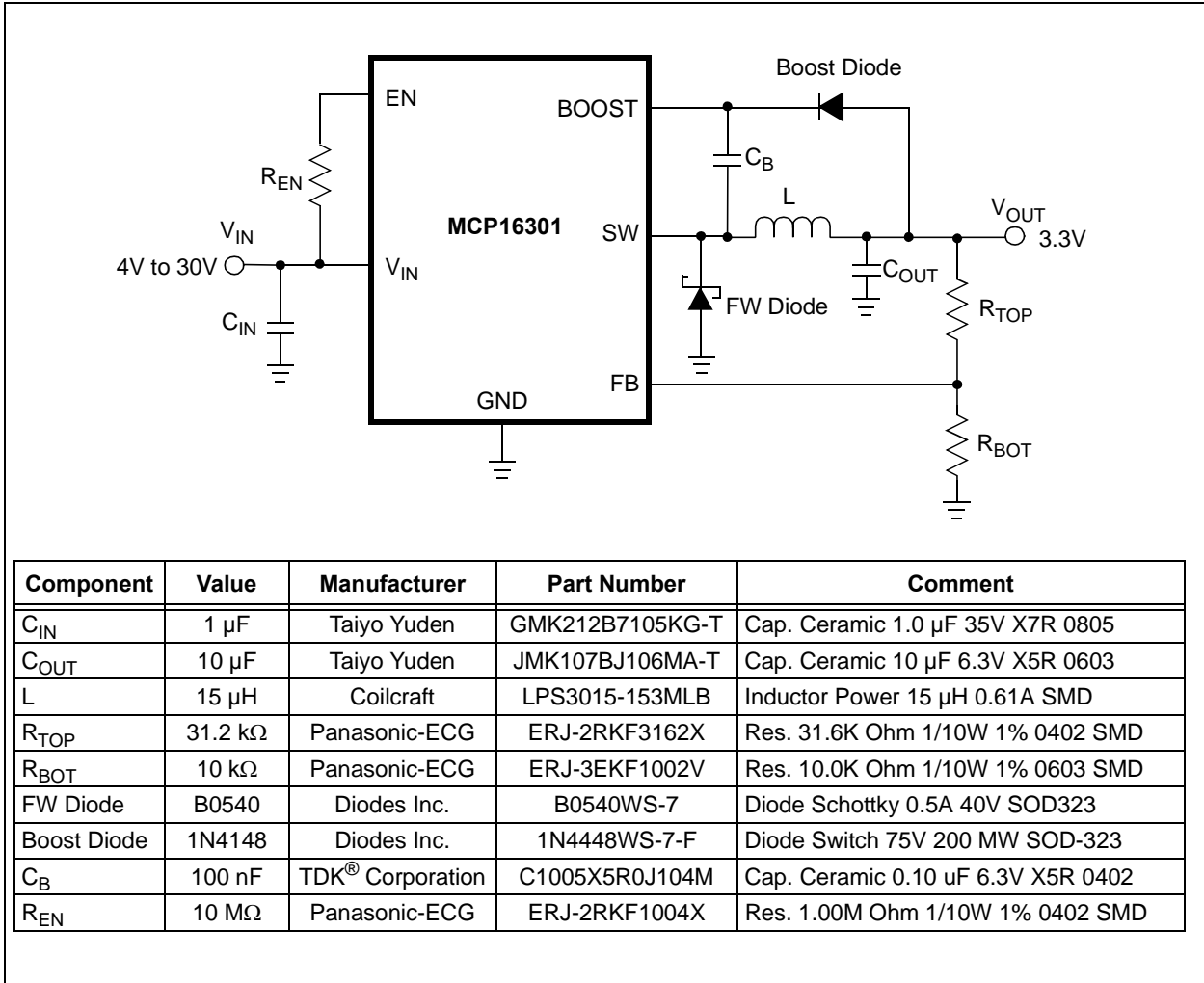

FIGURE 6-5: Typical Application 4V to 30V V_{IN} to 3.3V V_{OUT} at 150 mA.

MCP16301

NOTES:

7.0 PACKAGING INFORMATION

7.1 Package Marking Information

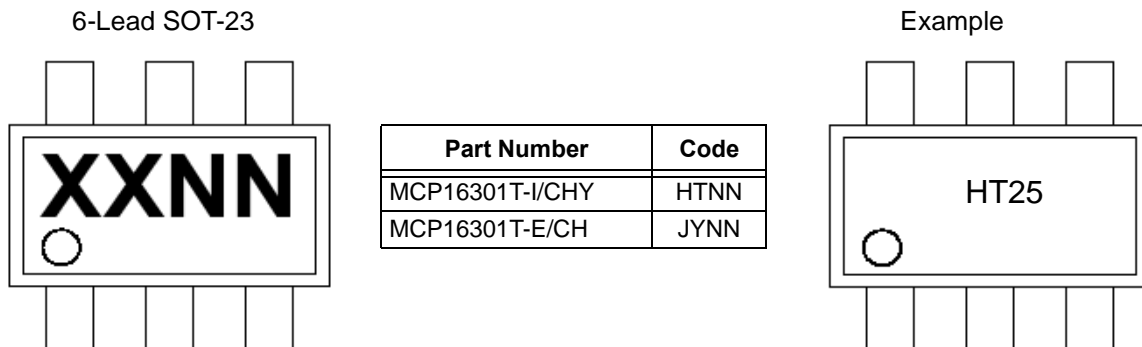

Legend:	XX...X	Customer-specific information
	Y	Year code (last digit of calendar year)
	YY	Year code (last 2 digits of calendar year)
	WW	Week code (week of January 1 is week '01')
	NNN	Alphanumeric traceability code
	(e3)	Pb-free JEDEC designator for Matte Tin (Sn)
	*	This package is Pb-free. The Pb-free JEDEC designator (e3) can be found on the outer packaging for this package.
Note:	In the event the full Microchip part number cannot be marked on one line, it will be carried over to the next line, thus limiting the number of available characters for customer-specific information.	

MCP16301

6-Lead Plastic Small Outline Transistor (CHY) [SOT-23]

Note: For the most current package drawings, please see the Microchip Packaging Specification located at <http://www.microchip.com/packaging>

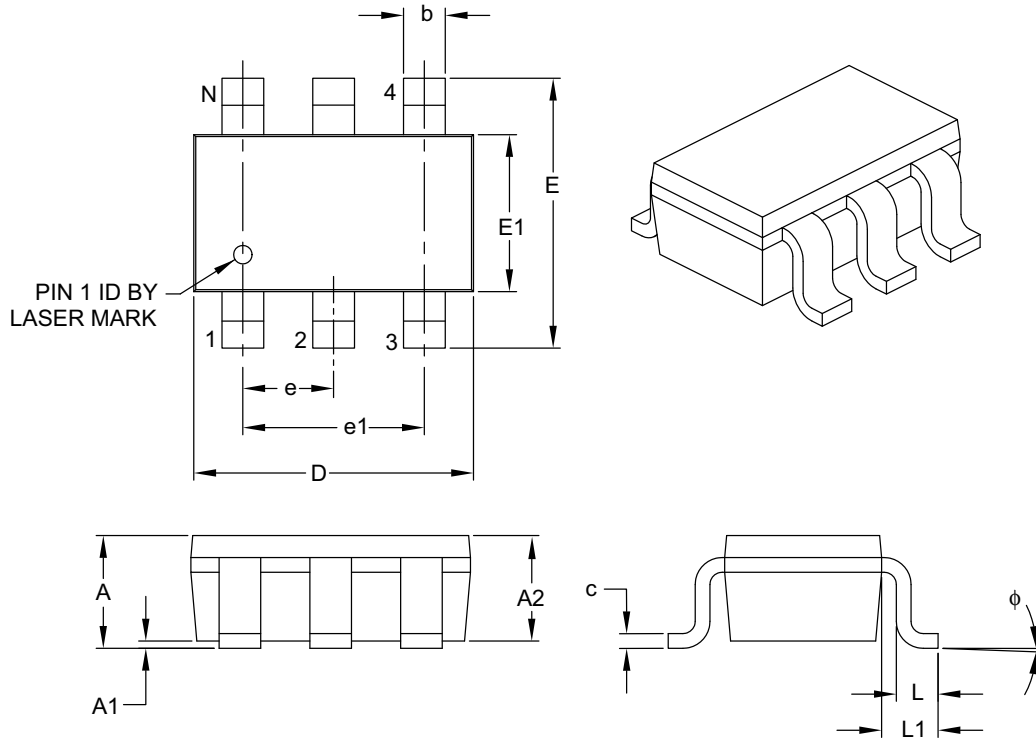

Dimension Limits	Units	MILLIMETERS		
		MIN	NOM	MAX
Number of Pins	N	6		
Pitch	e	0.95 BSC		
Outside Lead Pitch	e1	1.90 BSC		
Overall Height	A	0.90	–	1.45
Molded Package Thickness	A2	0.89	–	1.30
Standoff	A1	0.00	–	0.15
Overall Width	E	2.20	–	3.20
Molded Package Width	E1	1.30	–	1.80
Overall Length	D	2.70	–	3.10
Foot Length	L	0.10	–	0.60
Footprint	L1	0.35	–	0.80
Foot Angle	ϕ	0°	–	30°
Lead Thickness	c	0.08	–	0.26
Lead Width	b	0.20	–	0.51

Notes:

- Dimensions D and E1 do not include mold flash or protrusions. Mold flash or protrusions shall not exceed 0.127 mm per side.
- Dimensioning and tolerancing per ASME Y14.5M.

BSC: Basic Dimension. Theoretically exact value shown without tolerances.

Microchip Technology Drawing C04-028B

6-Lead Plastic Small Outline Transistor (CHY) [SOT-23]

Note: For the most current package drawings, please see the Microchip Packaging Specification located at <http://www.microchip.com/packaging>

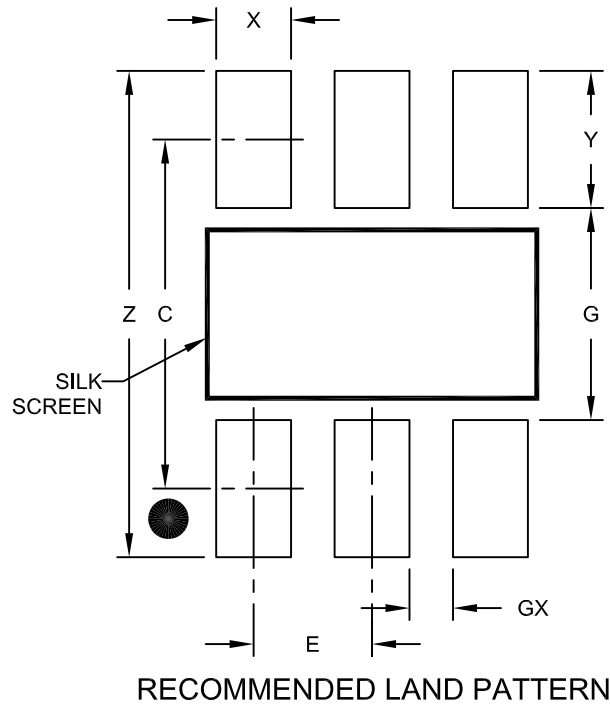

Dimension Limits	Units	MILLIMETERS		
		MIN	NOM	MAX
Contact Pitch	E	0.95 BSC		
Contact Pad Spacing	C		2.80	
Contact Pad Width (X6)	X			0.60
Contact Pad Length (X6)	Y			1.10
Distance Between Pads	G	1.70		
Distance Between Pads	GX	0.35		
Overall Width	Z			3.90

Notes:

1. Dimensioning and tolerancing per ASME Y14.5M

BSC: Basic Dimension. Theoretically exact value shown without tolerances.

Microchip Technology Drawing No. C04-2028A

MCP16301

6-Lead Plastic Small Outline Transistor (CH) [SOT-23]

Note: For the most current package drawings, please see the Microchip Packaging Specification located at <http://www.microchip.com/packaging>

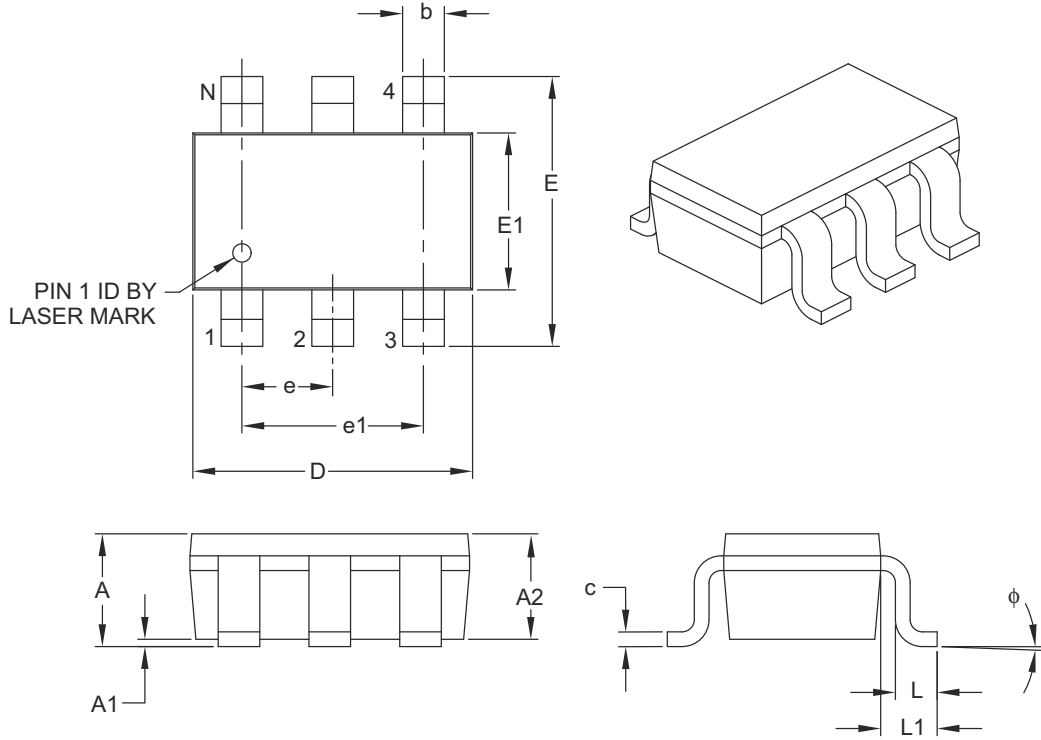

Dimension Limits	Units	MILLIMETERS		
		MIN	NOM	MAX
Number of Pins	N	6		
Pitch	e	0.95 BSC		
Outside Lead Pitch	e1	1.90 BSC		
Overall Height	A	0.90	–	1.45
Molded Package Thickness	A2	0.89	–	1.30
Standoff	A1	0.00	–	0.15
Overall Width	E	2.20	–	3.20
Molded Package Width	E1	1.30	–	1.80
Overall Length	D	2.70	–	3.10
Foot Length	L	0.10	–	0.60
Footprint	L1	0.35	–	0.80
Foot Angle	ϕ	0°	–	30°
Lead Thickness	c	0.08	–	0.26
Lead Width	b	0.20	–	0.51

Notes:

- Dimensions D and E1 do not include mold flash or protrusions. Mold flash or protrusions shall not exceed 0.127 mm per side.
- Dimensioning and tolerancing per ASME Y14.5M.

BSC: Basic Dimension. Theoretically exact value shown without tolerances.

Microchip Technology Drawing C04-028B

6-Lead Plastic Small Outline Transistor (CH) [SOT-23]

Note: For the most current package drawings, please see the Microchip Packaging Specification located at <http://www.microchip.com/packaging>

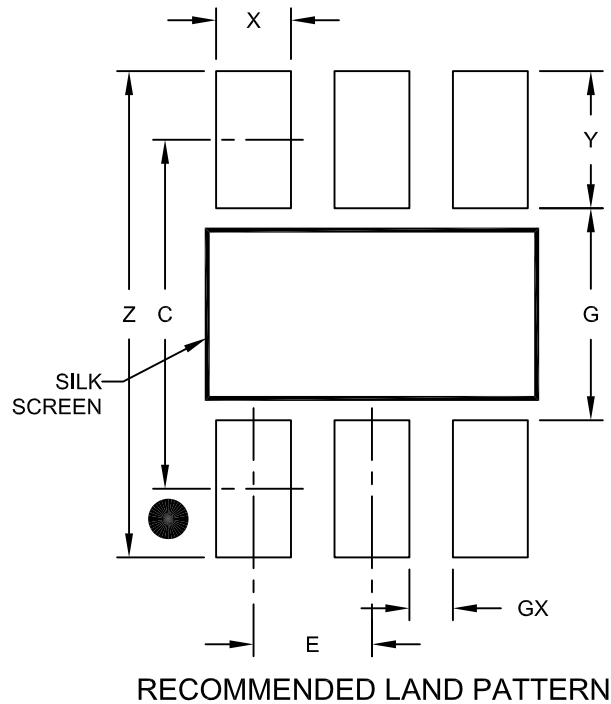

Dimension Limits	Units	MILLIMETERS		
		MIN	NOM	MAX
Contact Pitch	E	0.95 BSC		
Contact Pad Spacing	C		2.80	
Contact Pad Width (X6)	X			0.60
Contact Pad Length (X6)	Y			1.10
Distance Between Pads	G	1.70		
Distance Between Pads	GX	0.35		
Overall Width	Z			3.90

Notes:

1. Dimensioning and tolerancing per ASME Y14.5M

BSC: Basic Dimension. Theoretically exact value shown without tolerances.

Microchip Technology Drawing No. C04-2028A

MCP16301

NOTES:

APPENDIX A: REVISION HISTORY

Revision B (November 2012)

The following is the list of modifications:

1. Added Extended Temperature characteristic.
2. Added 6-lead SOT-23 package version (CH code).
3. Updated the following characterization charts: Figure [2-6](#), [2-7](#), [2-8](#), [2-9](#), [2-11](#), [2-12](#) and [2-13](#).
4. Updated [Section 7.0, Packaging Information](#).
5. Updated [Product Identification System](#).

Revision A (May 2011)

- Original Release of this Document.

MCP16301

NOTES:

PRODUCT IDENTIFICATION SYSTEM

To order or obtain information, e.g., on pricing or delivery, refer to the factory or the listed sales office.

<u>PART NO.</u>	<u>X</u>	<u>-X</u>	<u>/XXX</u>
Device	Tape and Reel	Temperature Range	Package
Device:	MCP16301T: High Voltage Step-Down Regulator, Tape and Reel		
Temperature Range:	E = -40°C to +125°C (Extended) I = -40°C to +85°C (Industrial)		
Package:	CH = Plastic Small Outline Transistor (SOT-23), 6-lead CHY* = Plastic Small Outline Transistor (SOT-23), 6-lead *Y = Nickel palladium gold manufacturing designator.		

Examples:

- a) MCP16301T-I/CHY: Step-Down Regulator, Tape and Reel, Industrial Temperature, 6LD SOT-23 package
- b) MCP16301T-E/CH: Step-Down Regulator, Tape and Reel, Extended Temperature, 6LD SOT-23 package

MCP16301

NOTES:

Note the following details of the code protection feature on Microchip devices:

- Microchip products meet the specification contained in their particular Microchip Data Sheet.
- Microchip believes that its family of products is one of the most secure families of its kind on the market today, when used in the intended manner and under normal conditions.
- There are dishonest and possibly illegal methods used to breach the code protection feature. All of these methods, to our knowledge, require using the Microchip products in a manner outside the operating specifications contained in Microchip's Data Sheets. Most likely, the person doing so is engaged in theft of intellectual property.
- Microchip is willing to work with the customer who is concerned about the integrity of their code.
- Neither Microchip nor any other semiconductor manufacturer can guarantee the security of their code. Code protection does not mean that we are guaranteeing the product as “unbreakable.”

Code protection is constantly evolving. We at Microchip are committed to continuously improving the code protection features of our products. Attempts to break Microchip's code protection feature may be a violation of the Digital Millennium Copyright Act. If such acts allow unauthorized access to your software or other copyrighted work, you may have a right to sue for relief under that Act.

Information contained in this publication regarding device applications and the like is provided only for your convenience and may be superseded by updates. It is your responsibility to ensure that your application meets with your specifications. MICROCHIP MAKES NO REPRESENTATIONS OR WARRANTIES OF ANY KIND WHETHER EXPRESS OR IMPLIED, WRITTEN OR ORAL, STATUTORY OR OTHERWISE, RELATED TO THE INFORMATION, INCLUDING BUT NOT LIMITED TO ITS CONDITION, QUALITY, PERFORMANCE, MERCHANTABILITY OR FITNESS FOR PURPOSE. Microchip disclaims all liability arising from this information and its use. Use of Microchip devices in life support and/or safety applications is entirely at the buyer's risk, and the buyer agrees to defend, indemnify and hold harmless Microchip from any and all damages, claims, suits, or expenses resulting from such use. No licenses are conveyed, implicitly or otherwise, under any Microchip intellectual property rights.

Trademarks

The Microchip name and logo, the Microchip logo, dsPIC, FlashFlex, KEELOQ, KEELOQ logo, MPLAB, PIC, PICmicro, PICSTART, PIC³² logo, rPIC, SST, SST Logo, SuperFlash and UNI/O are registered trademarks of Microchip Technology Incorporated in the U.S.A. and other countries.

FilterLab, Hampshire, HI-TECH C, Linear Active Thermistor, MTP, SEEVAL and The Embedded Control Solutions Company are registered trademarks of Microchip Technology Incorporated in the U.S.A.

Silicon Storage Technology is a registered trademark of Microchip Technology Inc. in other countries.

Analog-for-the-Digital Age, Application Maestro, BodyCom, chipKIT, chipKIT logo, CodeGuard, dsPICDEM, dsPICDEM.net, dsPICworks, dsSPEAK, ECAN, ECONOMONITOR, FanSense, HI-TIDE, In-Circuit Serial Programming, ICSP, Mindi, MiWi, MPASM, MPF, MPLAB Certified logo, MPLIB, MPLINK, mTouch, Omniclient Code Generation, PICC, PICC-18, PICDEM, PICDEM.net, PICkit, PICtail, REAL ICE, rLAB, Select Mode, SQI, Serial Quad I/O, Total Endurance, TSHARC, UniWinDriver, WiperLock, ZENA and Z-Scale are trademarks of Microchip Technology Incorporated in the U.S.A. and other countries.

SQTP is a service mark of Microchip Technology Incorporated in the U.S.A.

GestIC and ULPP are registered trademarks of Microchip Technology Germany II GmbH & Co. & KG, a subsidiary of Microchip Technology Inc., in other countries.

All other trademarks mentioned herein are property of their respective companies.

© 2011-2012, Microchip Technology Incorporated, Printed in the U.S.A., All Rights Reserved.

 Printed on recycled paper.

ISBN: 978-1-62076-684-2

QUALITY MANAGEMENT SYSTEM
CERTIFIED BY DNV
== ISO/TS 16949 ==

Microchip received ISO/TS-16949:2009 certification for its worldwide headquarters, design and wafer fabrication facilities in Chandler and Tempe, Arizona; Gresham, Oregon and design centers in California and India. The Company's quality system processes and procedures are for its PIC[®] MCUs and dsPIC[®] DSCs, KEELOQ[®] code hopping devices, Serial EEPROMs, microperipherals, nonvolatile memory and analog products. In addition, Microchip's quality system for the design and manufacture of development systems is ISO 9001:2000 certified.



MICROCHIP

Worldwide Sales and Service

AMERICAS

Corporate Office
2355 West Chandler Blvd.
Chandler, AZ 85224-6199
Tel: 480-792-7200
Fax: 480-792-7277
Technical Support:
<http://www.microchip.com/support>
Web Address:
www.microchip.com

Atlanta
Duluth, GA
Tel: 678-957-9614
Fax: 678-957-1455

Boston
Westborough, MA
Tel: 774-760-0087
Fax: 774-760-0088

Chicago
Itasca, IL
Tel: 630-285-0071
Fax: 630-285-0075

Cleveland
Independence, OH
Tel: 216-447-0464
Fax: 216-447-0643

Dallas
Addison, TX
Tel: 972-818-7423
Fax: 972-818-2924

Detroit
Farmington Hills, MI
Tel: 248-538-2250
Fax: 248-538-2260

Indianapolis
Noblesville, IN
Tel: 317-773-8323
Fax: 317-773-5453

Los Angeles
Mission Viejo, CA
Tel: 949-462-9523
Fax: 949-462-9608

Santa Clara
Santa Clara, CA
Tel: 408-961-6444
Fax: 408-961-6445

Toronto
Mississauga, Ontario,
Canada
Tel: 905-673-0699
Fax: 905-673-6509

ASIA/PACIFIC

Asia Pacific Office
Suites 3707-14, 37th Floor
Tower 6, The Gateway
Harbour City, Kowloon
Hong Kong
Tel: 852-2401-1200
Fax: 852-2401-3431

Australia - Sydney
Tel: 61-2-9868-6733
Fax: 61-2-9868-6755

China - Beijing
Tel: 86-10-8569-7000
Fax: 86-10-8528-2104

China - Chengdu
Tel: 86-28-8665-5511
Fax: 86-28-8665-7889

China - Chongqing
Tel: 86-23-8980-9588
Fax: 86-23-8980-9500

China - Hangzhou
Tel: 86-571-2819-3187
Fax: 86-571-2819-3189

China - Hong Kong SAR
Tel: 852-2401-1200
Fax: 852-2401-3431

China - Nanjing
Tel: 86-25-8473-2460
Fax: 86-25-8473-2470

China - Qingdao
Tel: 86-532-8502-7355
Fax: 86-532-8502-7205

China - Shanghai
Tel: 86-21-5407-5533
Fax: 86-21-5407-5066

China - Shenyang
Tel: 86-24-2334-2829
Fax: 86-24-2334-2393

China - Shenzhen
Tel: 86-755-8203-2660
Fax: 86-755-8203-1760

China - Wuhan
Tel: 86-27-5980-5300
Fax: 86-27-5980-5118

China - Xian
Tel: 86-29-8833-7252
Fax: 86-29-8833-7256

China - Xiamen
Tel: 86-592-2388138
Fax: 86-592-2388130

China - Zhuhai
Tel: 86-756-3210040
Fax: 86-756-3210049

ASIA/PACIFIC

India - Bangalore
Tel: 91-80-3090-4444
Fax: 91-80-3090-4123

India - New Delhi
Tel: 91-11-4160-8631
Fax: 91-11-4160-8632

India - Pune
Tel: 91-20-2566-1512
Fax: 91-20-2566-1513

Japan - Osaka
Tel: 81-66-152-7160
Fax: 81-66-152-9310

Japan - Yokohama
Tel: 81-45-471-6166
Fax: 81-45-471-6122

Korea - Daegu
Tel: 82-53-744-4301
Fax: 82-53-744-4302

Korea - Seoul
Tel: 82-2-554-7200
Fax: 82-2-558-5932 or
82-2-558-5934

Malaysia - Kuala Lumpur
Tel: 60-3-6201-9857
Fax: 60-3-6201-9859

Malaysia - Penang
Tel: 60-4-227-8870
Fax: 60-4-227-4068

Philippines - Manila
Tel: 63-2-634-9065
Fax: 63-2-634-9069

Singapore
Tel: 65-6334-8870
Fax: 65-6334-8850

Taiwan - Hsin Chu
Tel: 886-3-5778-366
Fax: 886-3-5770-955

Taiwan - Kaohsiung
Tel: 886-7-213-7828
Fax: 886-7-330-9305

Taiwan - Taipei
Tel: 886-2-2508-8600
Fax: 886-2-2508-0102

Thailand - Bangkok
Tel: 66-2-694-1351
Fax: 66-2-694-1350

EUROPE

Austria - Wels
Tel: 43-7242-2244-39
Fax: 43-7242-2244-393

Denmark - Copenhagen
Tel: 45-4450-2828
Fax: 45-4485-2829

France - Paris
Tel: 33-1-69-53-63-20
Fax: 33-1-69-30-90-79

Germany - Munich
Tel: 49-89-627-144-0
Fax: 49-89-627-144-44

Italy - Milan
Tel: 39-0331-742611
Fax: 39-0331-466781

Netherlands - Drunen
Tel: 31-416-690399
Fax: 31-416-690340

Spain - Madrid
Tel: 34-91-708-08-90
Fax: 34-91-708-08-91

UK - Wokingham
Tel: 44-118-921-5869
Fax: 44-118-921-5820

10/26/12



Компания «ЭлектроПласт» предлагает заключение долгосрочных отношений при поставках импортных электронных компонентов на взаимовыгодных условиях!

Наши преимущества:

- Оперативные поставки широкого спектра электронных компонентов отечественного и импортного производства напрямую от производителей и с крупнейших мировых складов;
- Поставка более 17-ти миллионов наименований электронных компонентов;
- Поставка сложных, дефицитных, либо снятых с производства позиций;
- Оперативные сроки поставки под заказ (от 5 рабочих дней);
- Экспресс доставка в любую точку России;
- Техническая поддержка проекта, помощь в подборе аналогов, поставка прототипов;
- Система менеджмента качества сертифицирована по Международному стандарту ISO 9001;
- Лицензия ФСБ на осуществление работ с использованием сведений, составляющих государственную тайну;
- Поставка специализированных компонентов (Xilinx, Altera, Analog Devices, Intersil, Interpoint, Microsemi, Aeroflex, Peregrine, Syfer, Eurofarad, Texas Instrument, Miteq, Cobham, E2V, MA-COM, Hittite, Mini-Circuits, General Dynamics и др.);

Помимо этого, одним из направлений компании «ЭлектроПласт» является направление «Источники питания». Мы предлагаем Вам помощь Конструкторского отдела:

- Подбор оптимального решения, техническое обоснование при выборе компонента;
- Подбор аналогов;
- Консультации по применению компонента;
- Поставка образцов и прототипов;
- Техническая поддержка проекта;
- Защита от снятия компонента с производства.



Как с нами связаться

Телефон: 8 (812) 309 58 32 (многоканальный)

Факс: 8 (812) 320-02-42

Электронная почта: org@eplast1.ru

Адрес: 198099, г. Санкт-Петербург, ул. Калинина, дом 2, корпус 4, литера А.