

3M™ HM PRESS-FIT HEADER, 8-ROW, HM SERIES  
FOR HARD METRIC APPLICATIONS

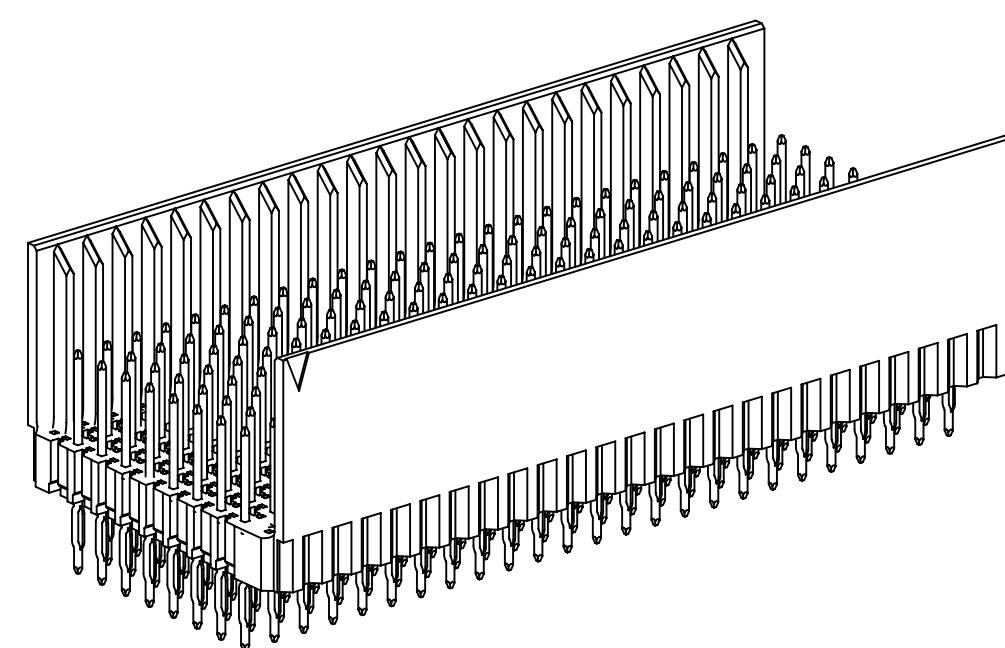

HM-H200E1-8CX1  
HM-H244E2-8BX1

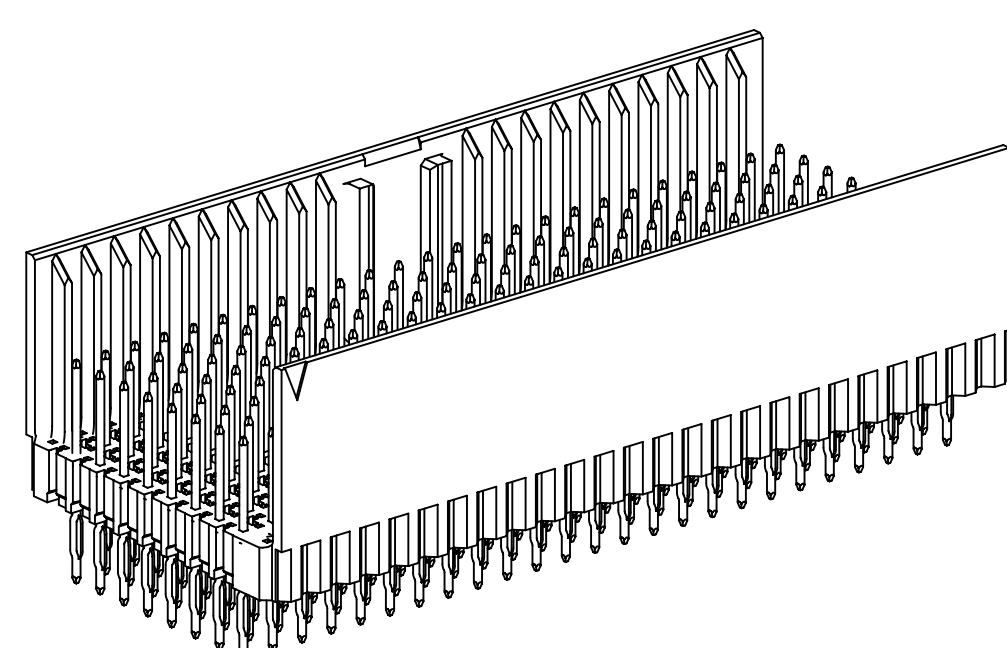

HM-H200DE1-8CX1  
HM-H244DE2-8BX1

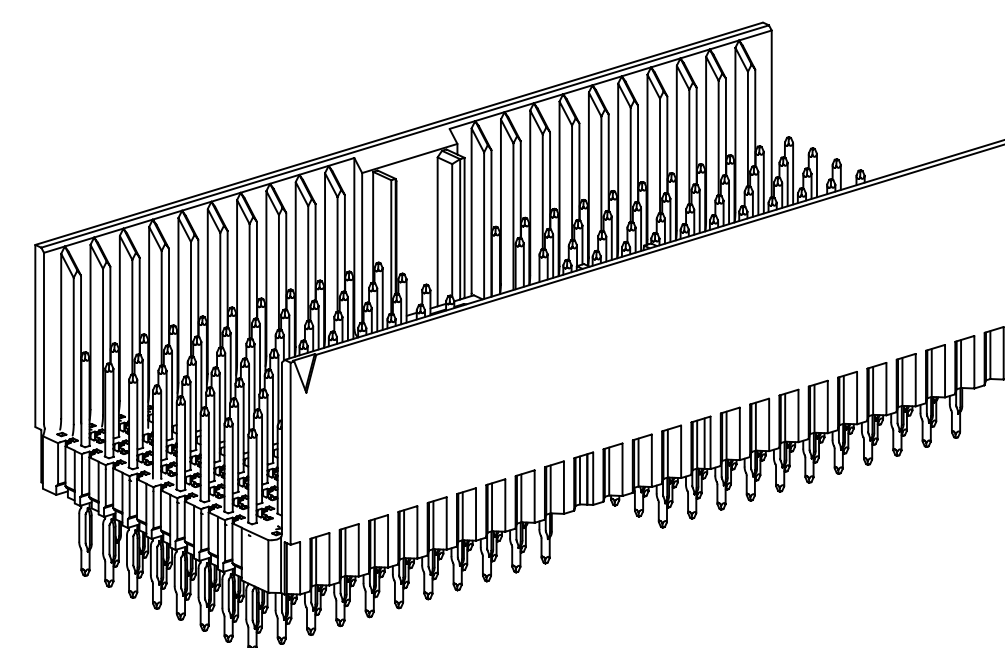

HM-H176D1-8CX1  
HM-H220D2-8BX1

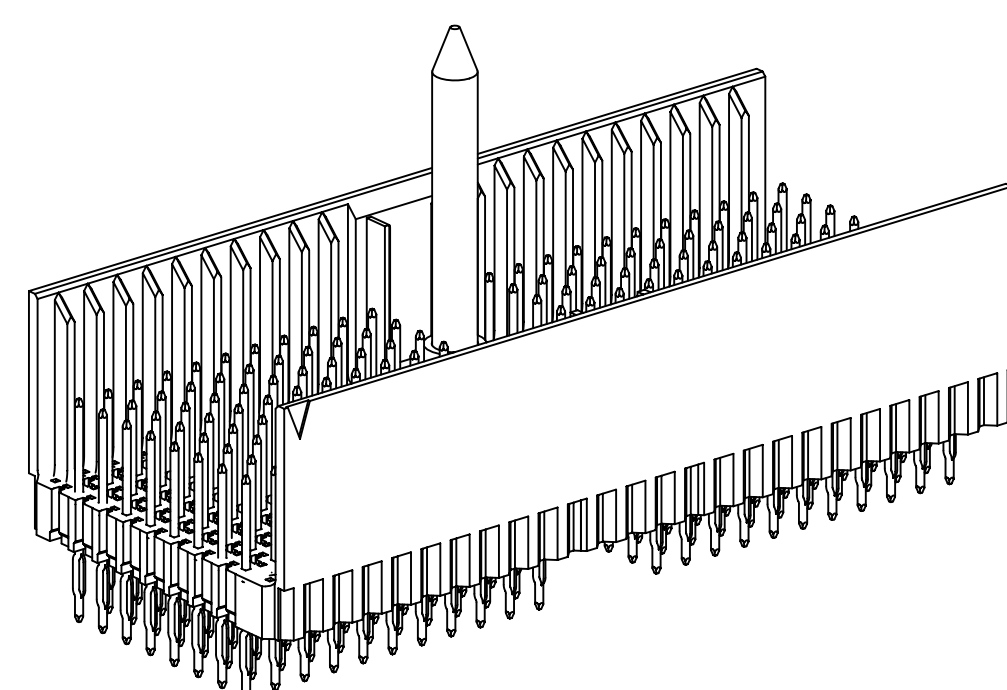

HM-H176DG1-8CX1  
HM-H220DG2-8BX1

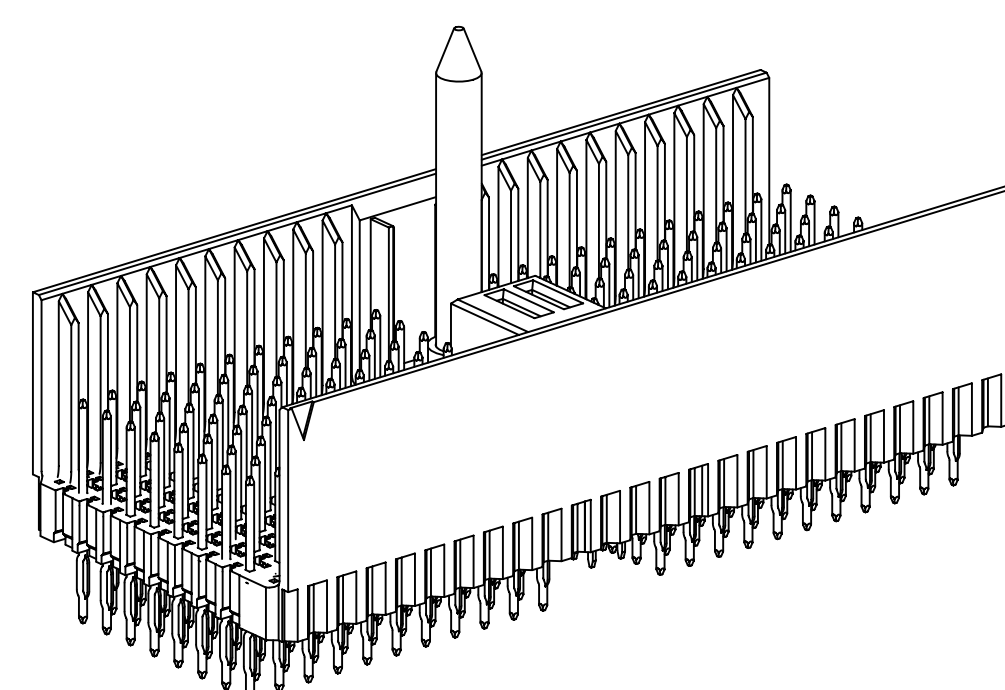

HM-H176DPWR1-8CX1  
HM-H220DPWR2-8BX1

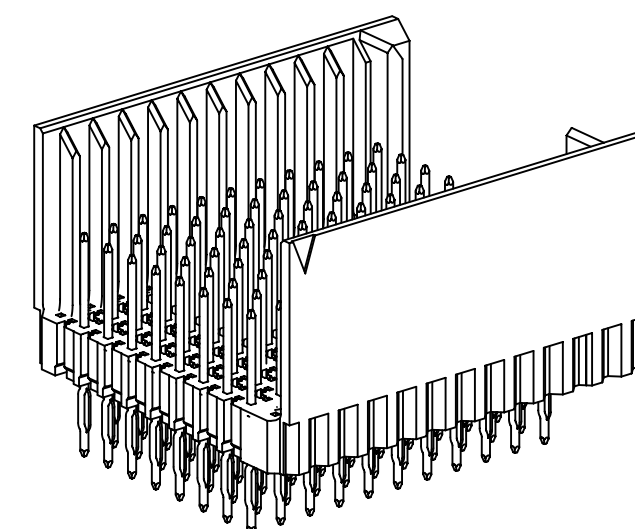

HM-H088FL1-8CX1  
HM-H110FL2-8BX1

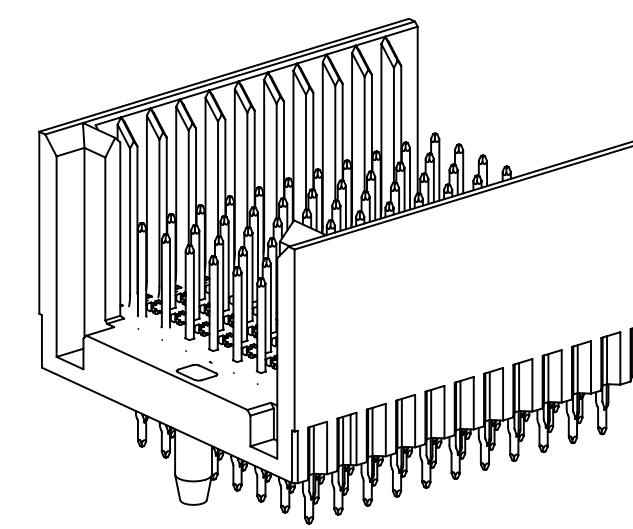

HM-H088FR1-8CX1  
HM-H110FR2-8BX1

(UNLESS OTHERWISE SHOWN)  
ORDERING INFORMATION  
(ROWS I AND Z NOT LOADED)

HM-HXXXXX1-8CX1-XXXXX

HEADER POSITION AND TYPE      TAIL STYLE:  
P = PRESS-FIT TAIL  
S = SOLDER TAIL      PLATING

(UNLESS OTHERWISE SHOWN)  
ORDERING INFORMATION  
(ROWS I AND Z LOADED, 8.3MM MATE LENGTH)

HM-HXXXXX2-8BX1-XXXXX

HEADER POSITION AND TYPE      TAIL STYLE:  
P = PRESS-FIT TAIL  
S = SOLDER TAIL      PLATING

PLATING SPECIFICATIONS:

TG30L = .76µM [30µIN] MIN. GOLD ON CONTACT AREA, LUBRICATED  
2.54µM [100µIN] MIN. TIN/LEAD ON TERMINAL AREA (RIA C2 & E2 APPLY)  
1.27µM [50µIN] MIN. NICKEL ALL OVER.  
TYPICALLY HIGHER MAKE ORDER QUANTITIES AS COMPARED TO TG30.

TG30 = .76µM [30µIN] MIN. GOLD ON CONTACT AREA  
2.54µM [100µIN] MIN. TIN/LEAD ON TERMINAL AREA (RIA C2 & E2 APPLY)  
1.27µM [50µIN] MIN. NICKEL ALL OVER.  
STANDARD OPTION.

TG50 = 1.27µM [50µIN] MIN. GOLD ON CONTACT AREA, LUBRICATED  
2.54µM [100µIN] MIN. TIN/LEAD ON TERMINAL AREA (RIA C2 & E2 APPLY)  
1.27µM [50µIN] MIN. NICKEL ALL OVER.  
NON-STANDARD OPTION (AVAILABLE WITH LONGER LEAD TIMES AND HIGHER MAKE ORDER QUANTITIES, MOQ)

KR = .76µM [30µIN] MIN. GOLD ON CONTACT AREA  
2.54µM [100µIN] MIN. MATTE TIN ON TERMINAL AREA (RIA C2 & E2 APPLY)  
1.27µM [50µIN] MIN. NICKEL ALL OVER.

- \* MODULAR/SCALABLE FORMAT IEC 61076-4-101
- \* PRESS-FIT OF SOLDER TAIL VERSION
- \* 101 MATED LINES PER INCH
- \* SHIPS WITH PROTECTIVE CAP, WHICH ALSO SERVES AS AN INSERTION TOOL
- \* END-TO-END STACKABLE WITH 8 ROW 3M™ HM AND HSHM PRODUCTS
- \* INTEGRATED GUIDE AND GUIDE PIN
- \* MULTI-PURPOSE CENTER (MPC) KEYING AND GUIDANCE
- \* FOUR INTEGRATED 8.25 A POWER CONTACTS AND GUIDE PIN

- NOTES
1. MATERIAL:  
PLASTIC: HIGH TEMP LCP, UL94V-0  
PINS: COPPER ALLOY.
  2. REGULATORY INFORMATION:  
ROHS COMPLIANT. SEE THE REGULATORY INFORMATION APPENDIX (RIA) IN THE "ROHS COMPLIANCE" SECTION OF WWW.3MCONNECTORS.COM FOR COMPLIANCE INFORMATION (RIA E1 & C1 APPLY)
  3. IN THE EVENT OF CONFLICT BETWEEN THIS DATA AND THAT CONTAINED IN THE PRODUCT SPECIFICATION, THE PRODUCT SPECIFICATION TAKES PRECEDENT.

MECHANICAL:

NORMAL FORCE (NOMINAL): .57N [58g] SIGNAL  
ENGAGEMENT FORCE (NOMINAL): .32N [33g] SIGNAL  
SEPARATION FORCE (NOMINAL): .20N [20g] SIGNAL  
WIPE (NOMINAL, SHORTEST CONTACT): 2.67 [.105] SIGNAL  
MATE/UNMATE CYCLES: 250  
APPLICATION: THIS MODULE IS NOT SUITABLE FOR STAND-ALONE USE. (REFER TO IEC-61076-4-101)

ELECTRICAL:

CURRENT RATING (FULLY LOADED): 1A @ 70°C SIGNAL  
INSULATION RESISTANCE: 1 X 10<sup>4</sup> MΩ @ 100 V<sub>DC</sub>  
WITHSTANDING VOLTAGE: 750V<sub>RMS</sub>

ENVIRONMENTAL:

TEMPERATURE RATING: -55°C TO 125°C  
PROCESS RATING: MAX. 260°C (PER J-STD-020C)  
WITHSTANDING VOLTAGE: 1 (PER J-STD-020C)

3M™ ELECTRONIC SOLUTIONS DIVISION  
INTERCONNECT SOLUTIONS  
<http://www.3mconnectors.com>

3M IS A TRADEMARK OF 3M COMPANY.  
FOR TECHNICAL, SALES OR ORDERING  
INFORMATION CALL 800-225-5373

**CAUS**  
UL FILE NO: E68080

DESIGN REFERENCE		NEXT ASSEMBLY		REV	ECO	ISSUE DATE AND DESCRIPTION	DRFT	CHKD
CAGD		CAGD		001		MAR 28, 2012		
DIVISION		DIVISION CODE		DATE		DATE		
Interconnect Solutions		ISD		T. SUNIGA		MAR 28, 2012		
DO NOT SCALE DRAWING	SCALE 5/2	TOLERANCES EXCEPT AS NOTED		3M		© 3M COPYRIGHT 2012 This document and the information it contains are 3M property and may not be reproduced or further distributed without 3M permission, or used or disclosed other than for 3M authorized purposes. All rights reserved.		
THIRD ANGLE PROJECTION		MILLIMETERS		TITLE				
INTERPRET PER ASME Y14.5 - 1994		0 ± .01 .000 ± .005 -.0000 ±		HM PRESS-FIT HEADER, 8-ROW, HM SERIES				
MAX SURFACE ROUGHNESS		0 ± .3 .00 ± .13 .000 ±		CAGE NUMBER		DRAWING NO.		REV.
MARKED ONLY		ANGLES		D78-5100-2517-0		A		
				MODEL		SHT 1 OF 4		

78-5100-2517-0  
DRAWING NUMBER

A  
REVISION

B

A

3M™ HM PRESS-FIT HEADER, 8-ROW, HM SERIES  
FOR HARD METRIC APPLICATIONS

NOTES  
1 CAPS TO BE REMOVED AFTER PRESS-FIT INSTALLATION PROCESS.

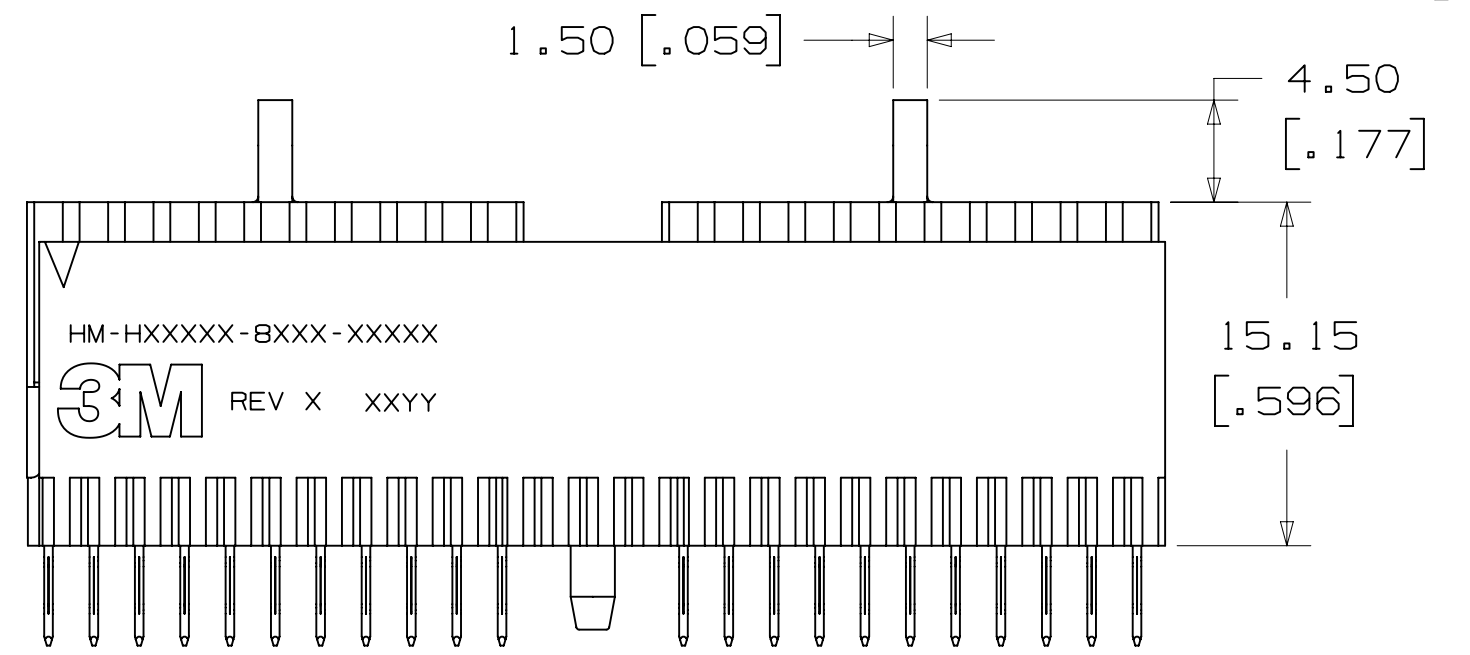
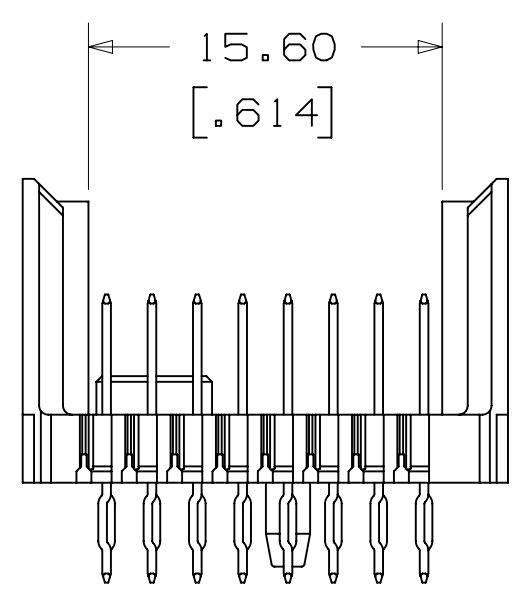
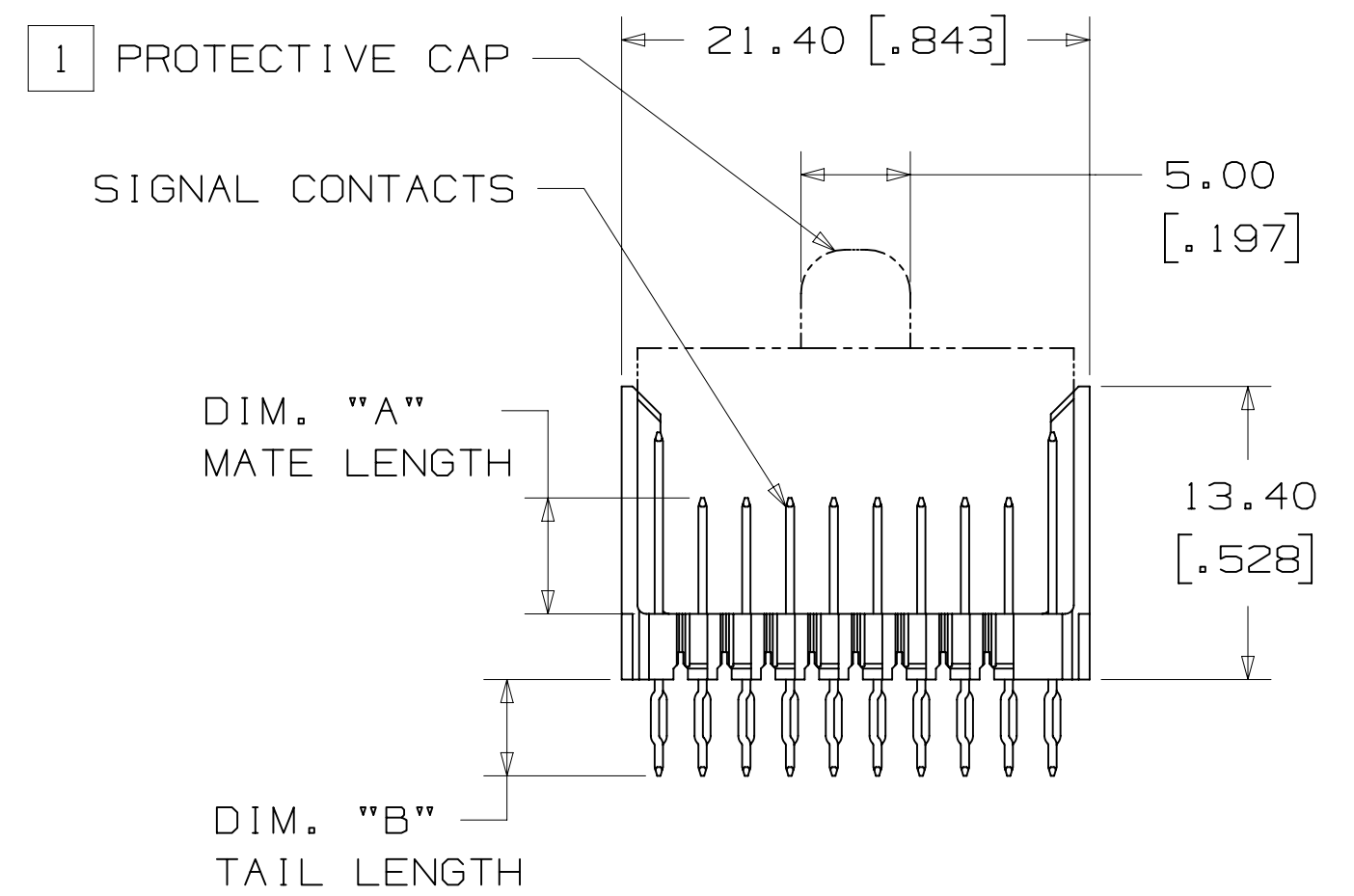
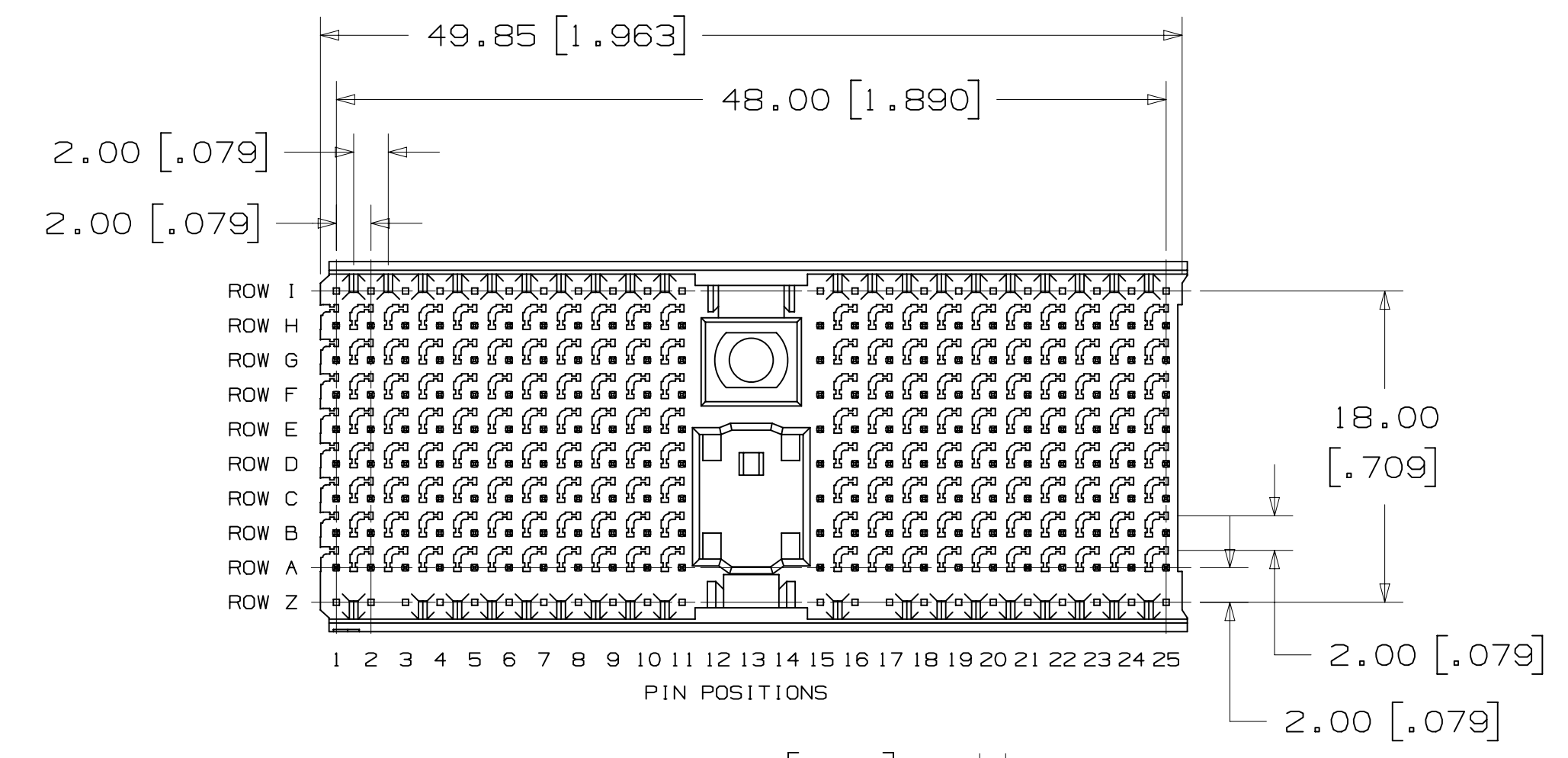
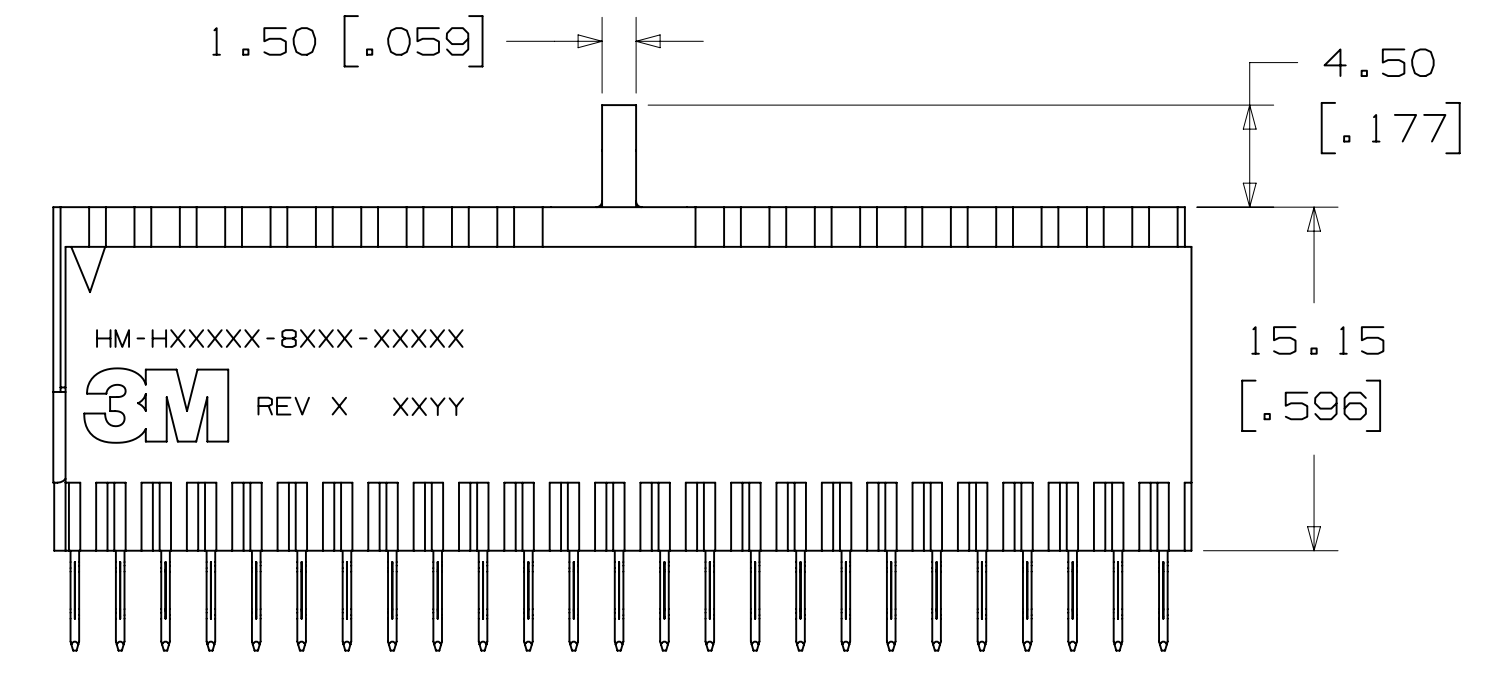
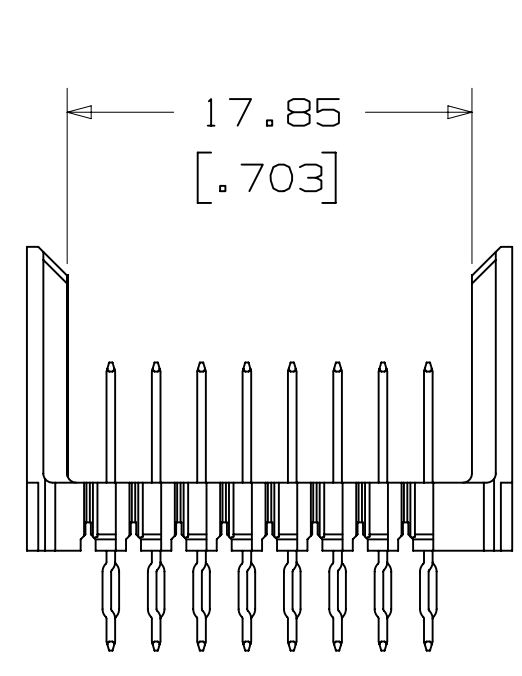
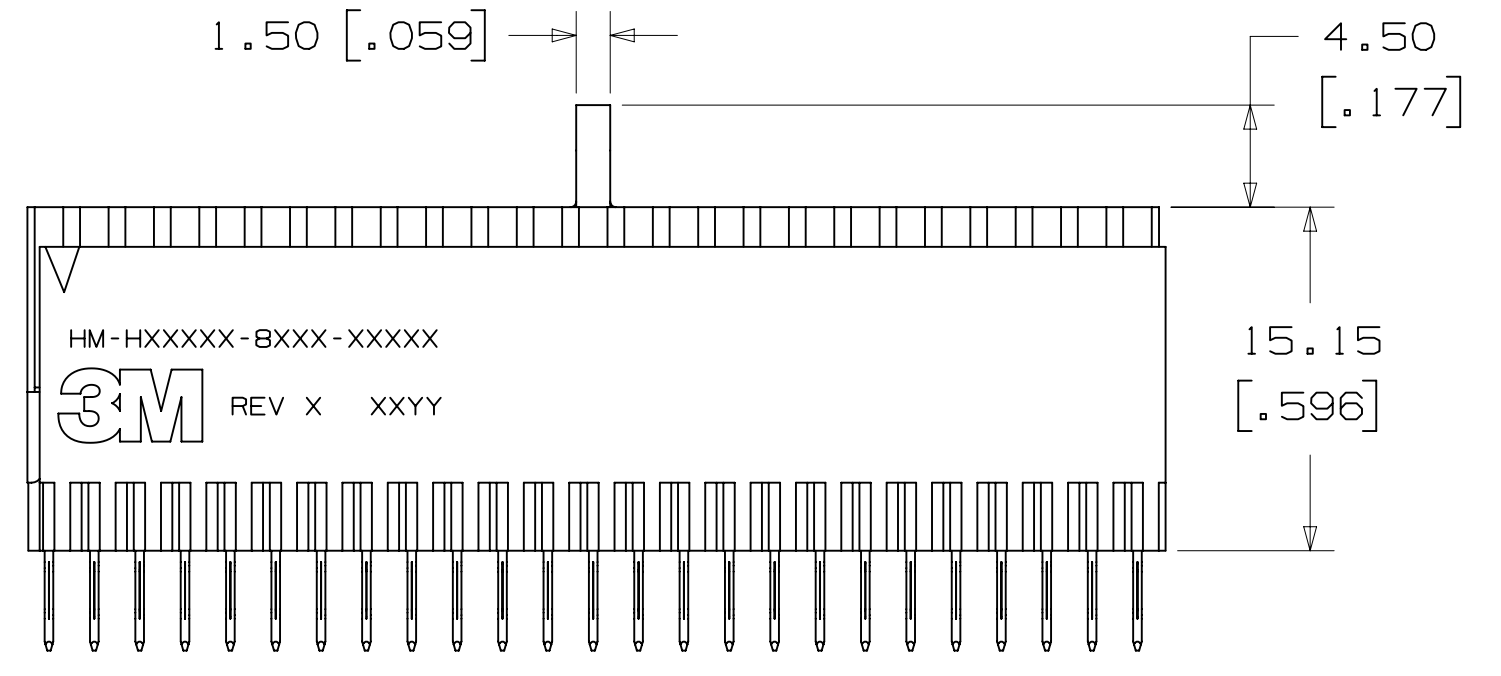
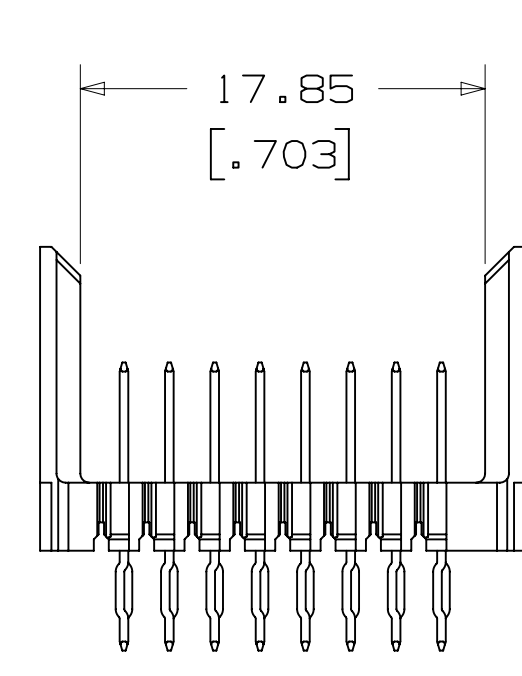
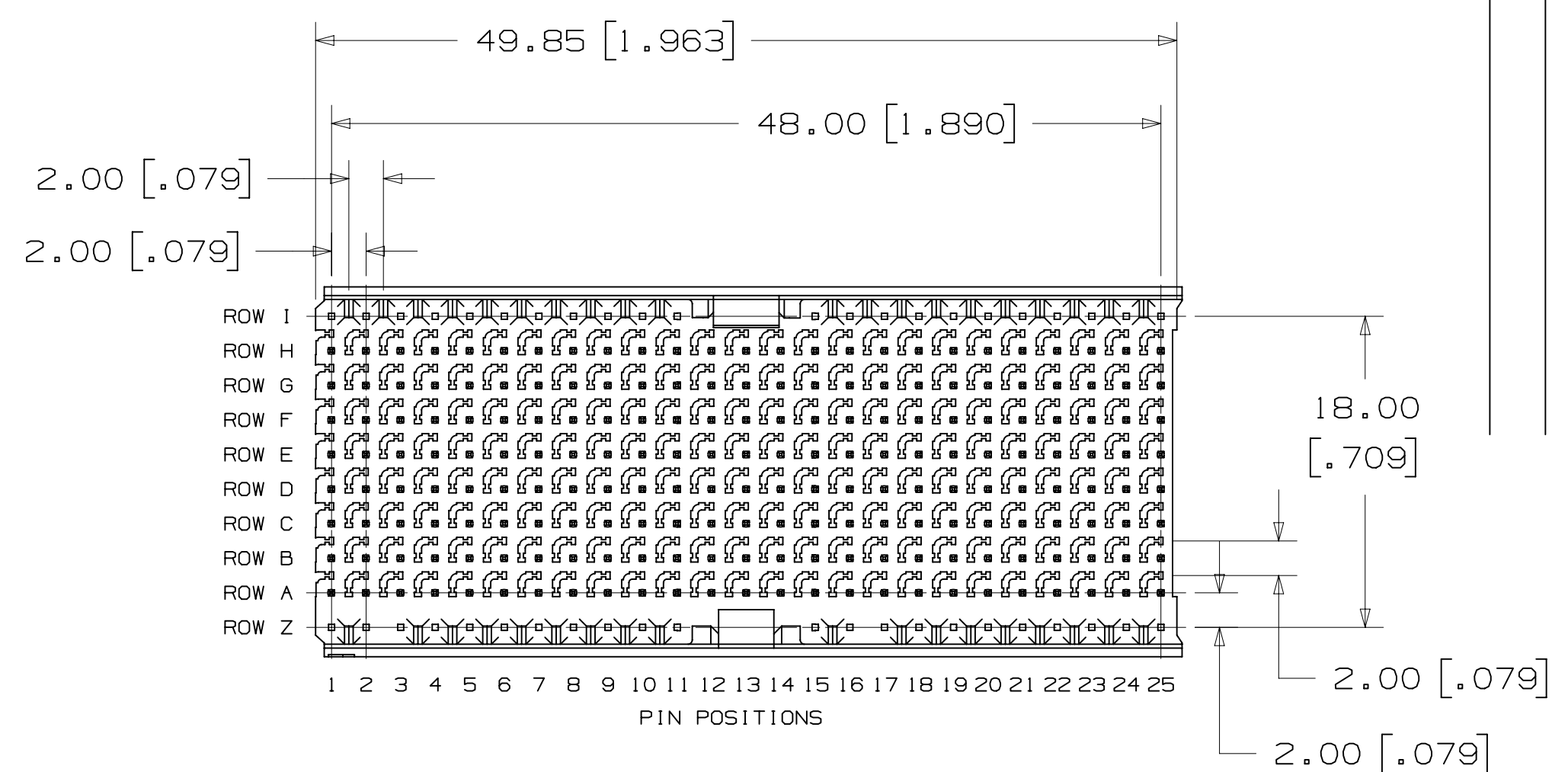
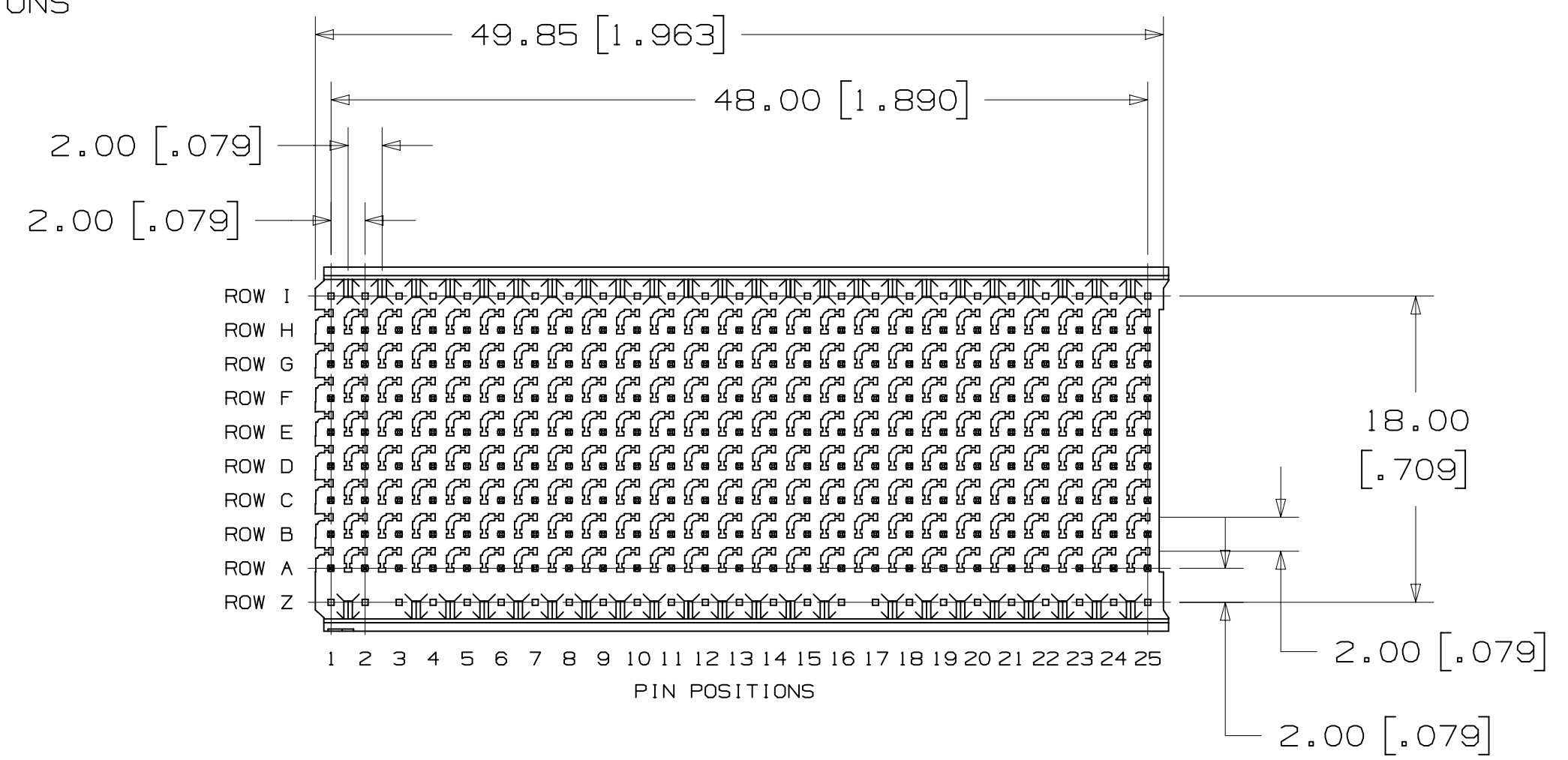

TYPICAL SIDE VIEW DIMENSIONS FOR THE HEADERS ON THIS DRAWING

STANDARD CONFIGURATION  
DIM. "A" 5.3 [.21] FOR ROWS A THRU H  
DIM. "B" 4.4 [.17] EXCEPT AS NOTED  
FOR NON-STANDARD CONFIGURATIONS CONTACT A 3M SALES REPRESENTATIVE

DESIGN REFERENCE	NEXT ASSEMBLY	REV	ECO	ISSUE DATE AND DESCRIPTION	DRFT	CHKD
		A	39815	MAR 28, 2012 PRODUCTION RELEASE	JNC	TS
DIVISION		SCALE		TOLERANCES EXCEPT AS NOTED		
Interconnect Solutions		3/1		INCHES .00 ± .01 .000 ± .005 .0000 ±		
DO NOT SCALE DRAWING		INTERPRET PER ASME Y14.5 - 1994		MILLIMETERS 0 ± .00 ± .13 .000 ±		© 3M COPYRIGHT 2012 This document and the information it contains are 3M property and may not be reproduced or further distributed without 3M permission, or used or disclosed other than for 3M authorized purposes. All rights reserved.
THIRD ANGLE PROJECTION		MAX SURFACE ROUGHNESS		CAGE NUMBER		
		SURFACES MARKED ONLY		D 78-5100-2517-0		
				REV. A		
				SHT 2 OF 4		

3M™ HM PRESS-FIT HEADER, 8-ROW, HM SERIES  
FOR HARD METRIC APPLICATIONS

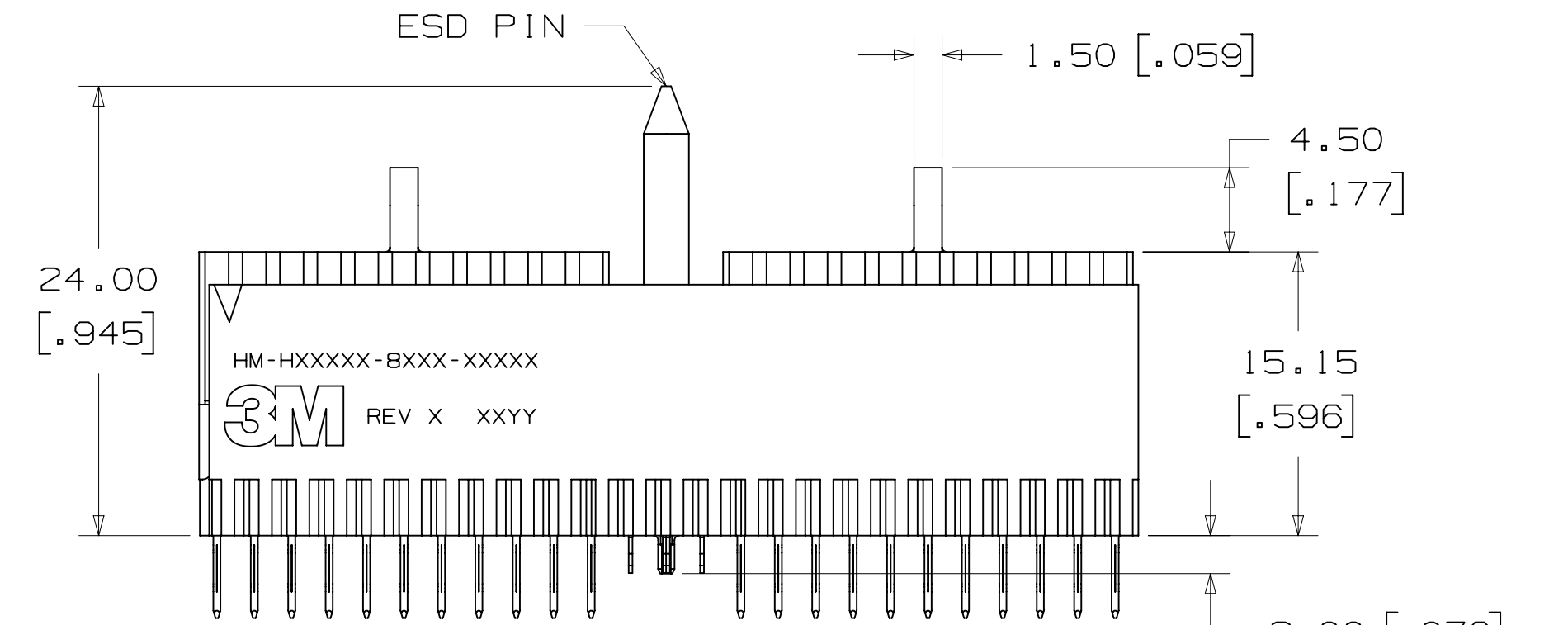
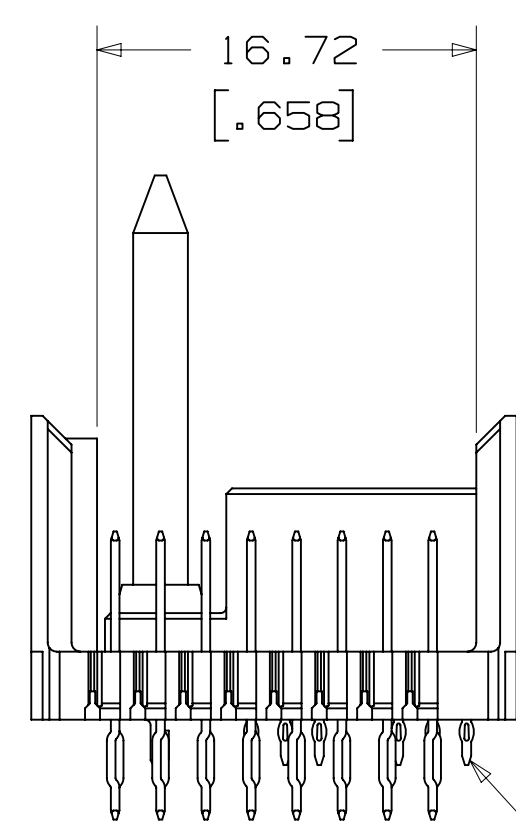
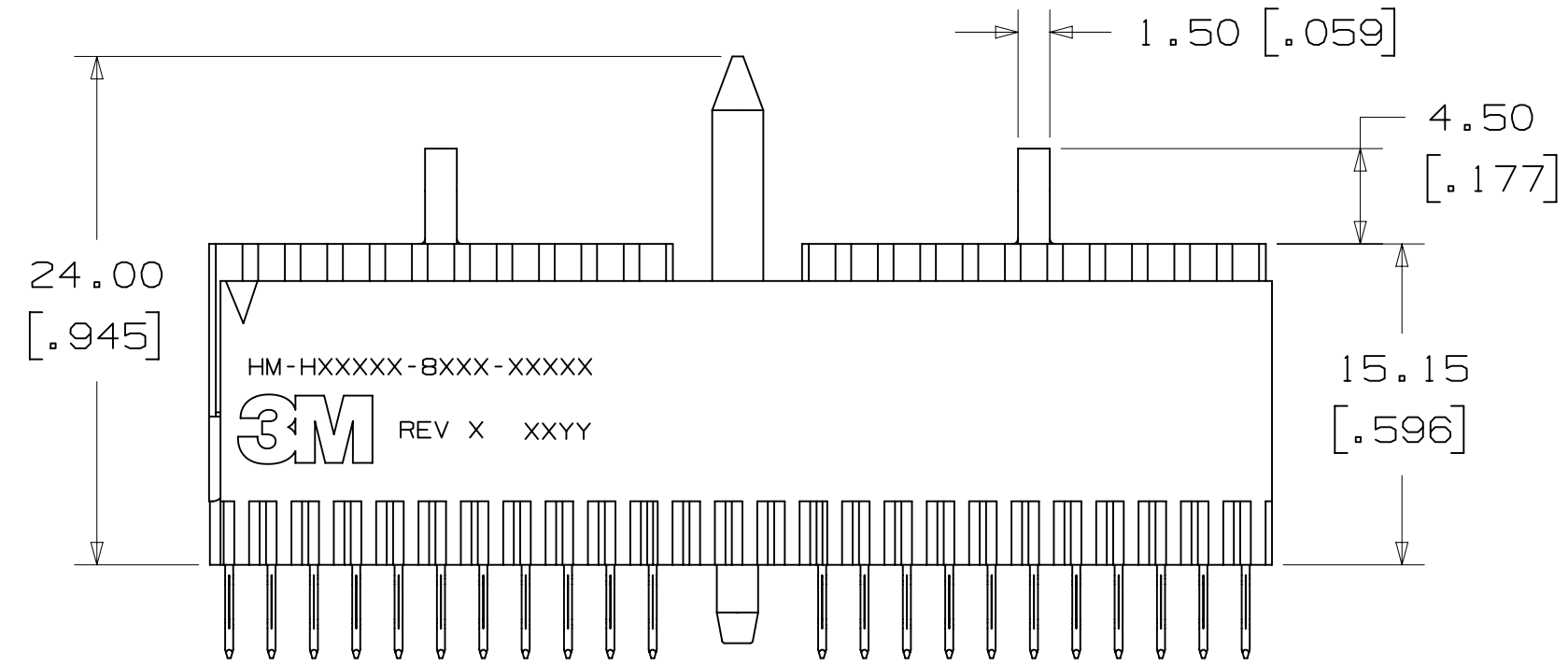
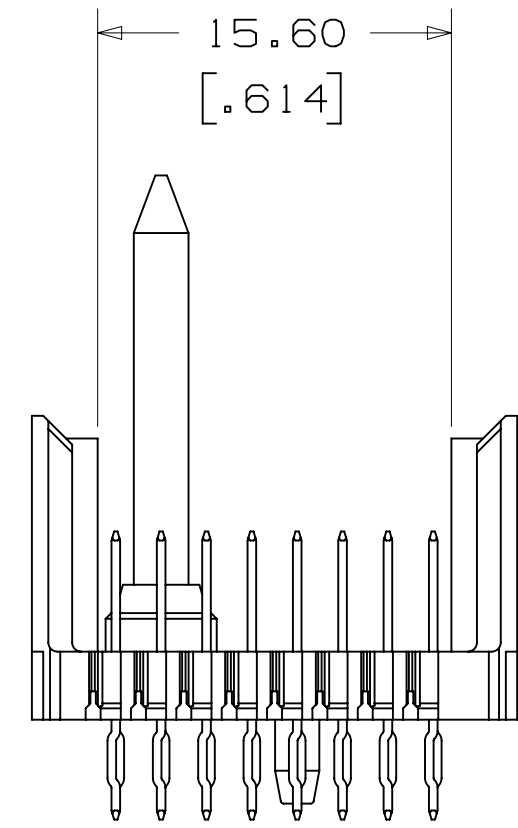
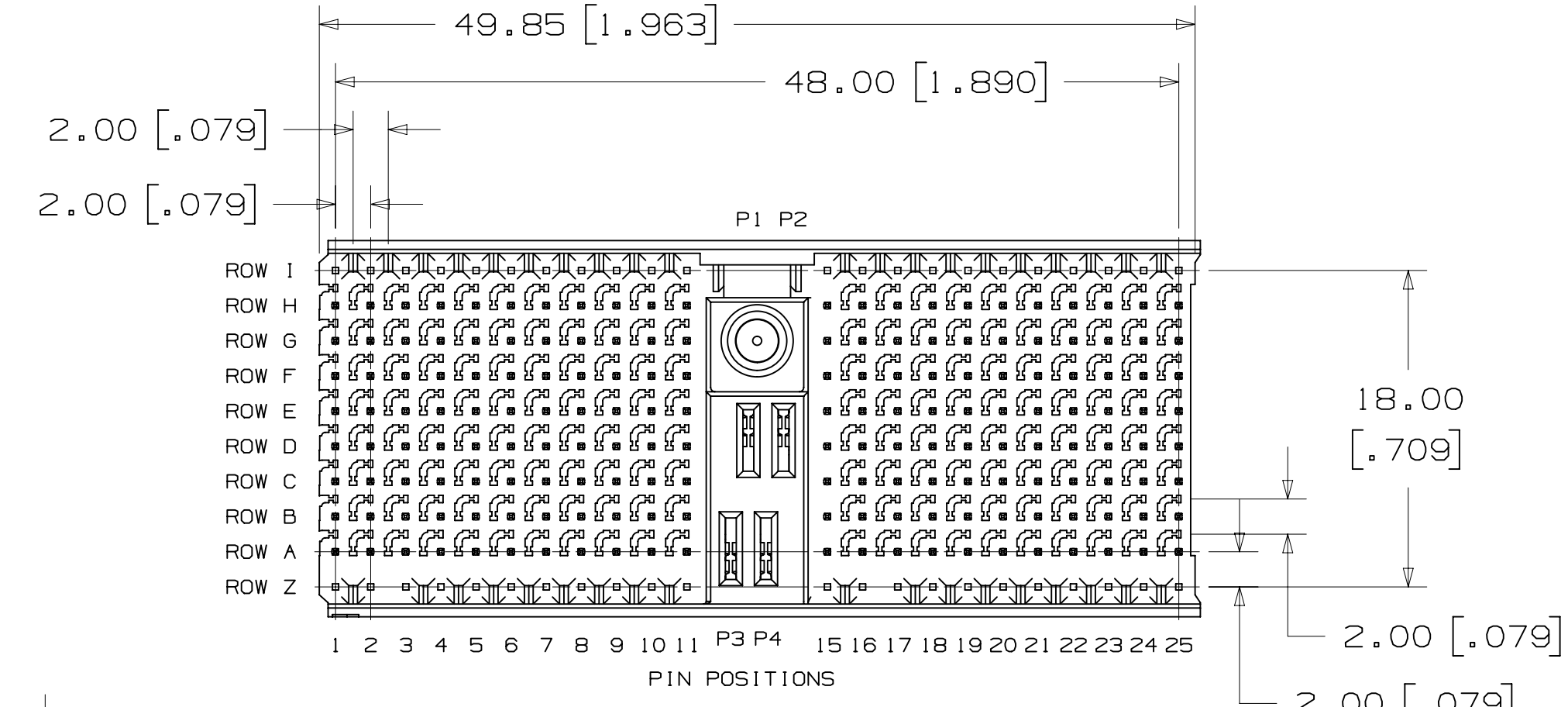
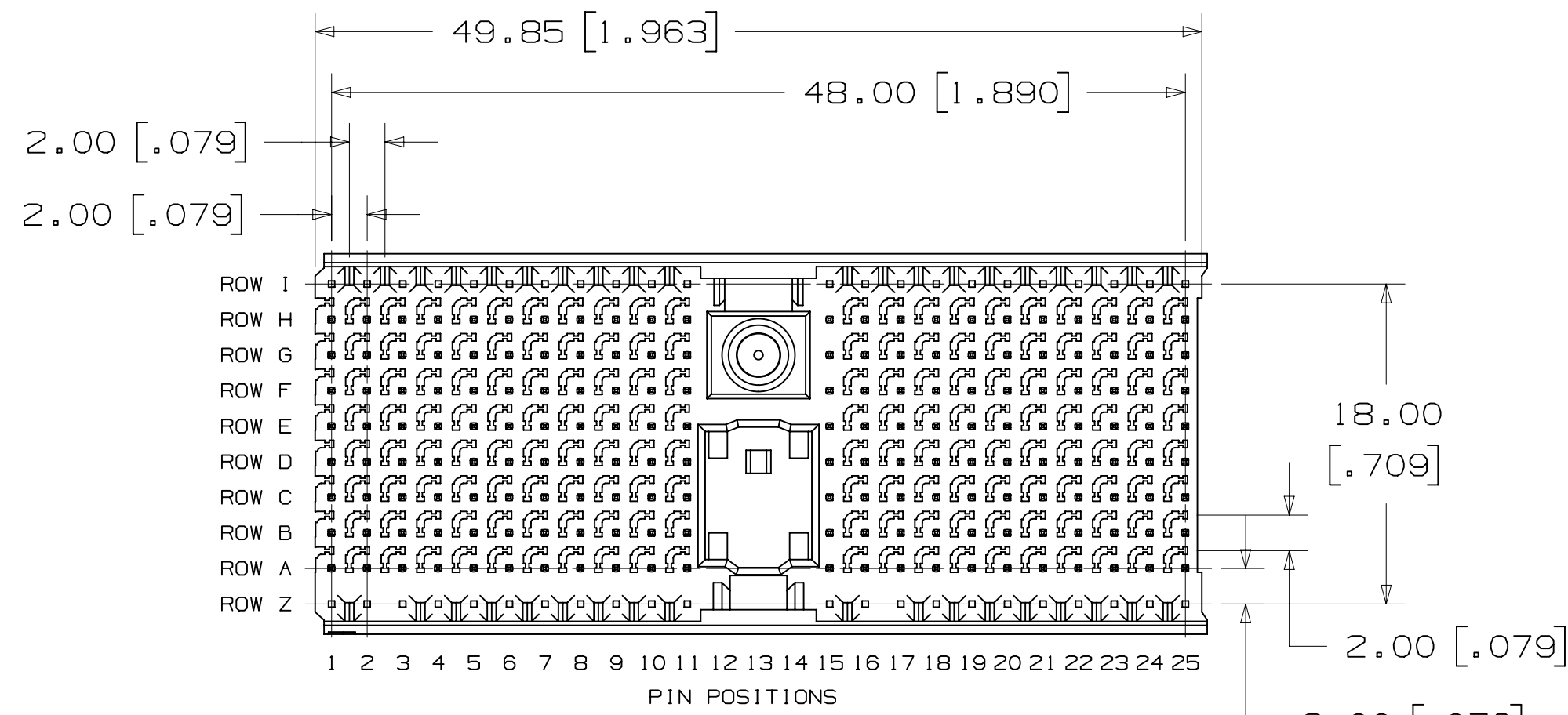

HM-H176DG1-8CX1  
HM-H220DG2-8BX1

HM-H176DPWR1-8CXX  
HM-H220DPWR2-8BXX

DIM. "B" TAIL LENGTH  
1 = 4.4 [.17] PIN, 2.0 [.08] POWER AND 2.0 [.08] ESD  
2 = 4.4 [.17] PIN, 4.4 [.17] POWER AND 2.0 [.08] ESD

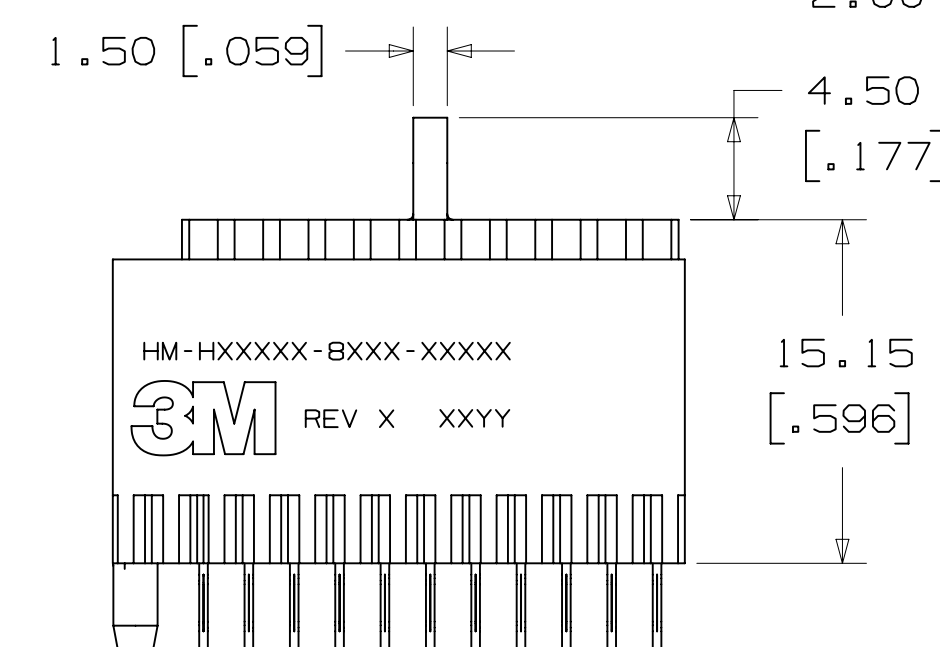
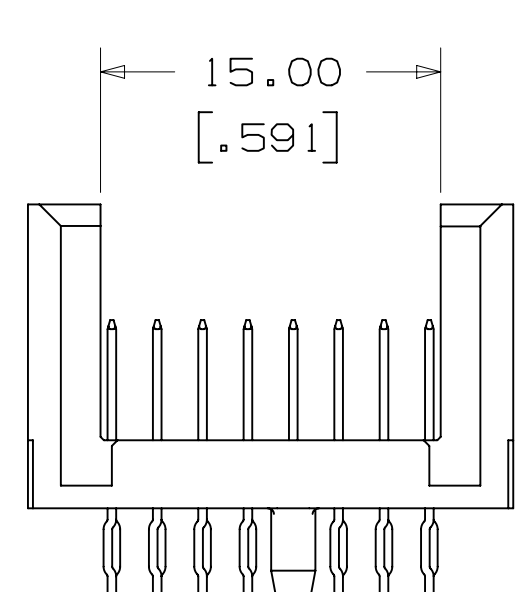
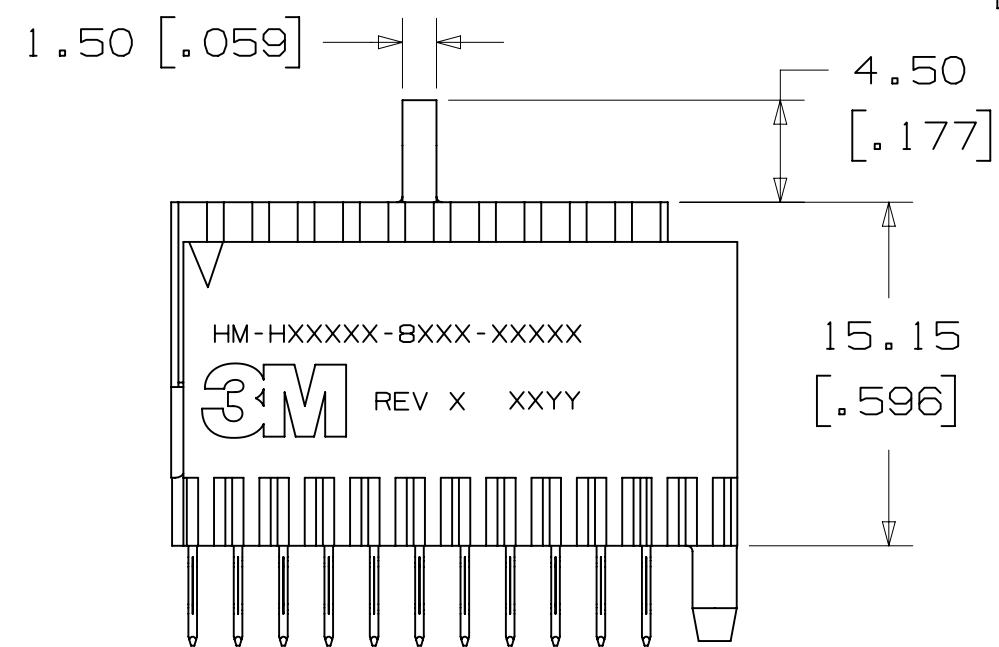
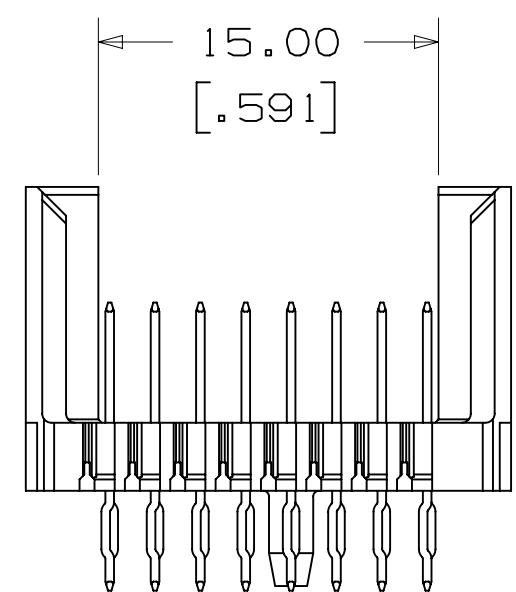
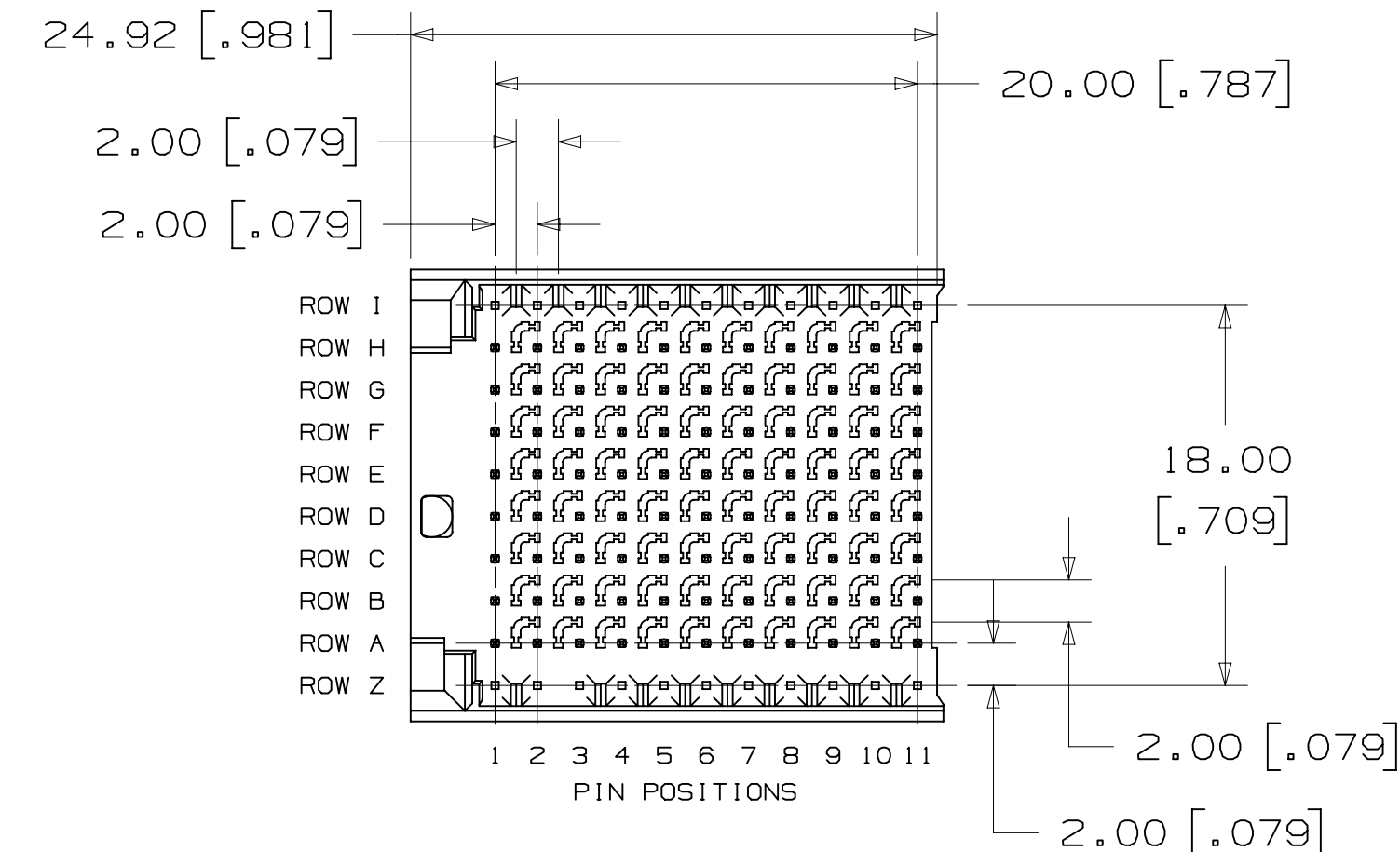
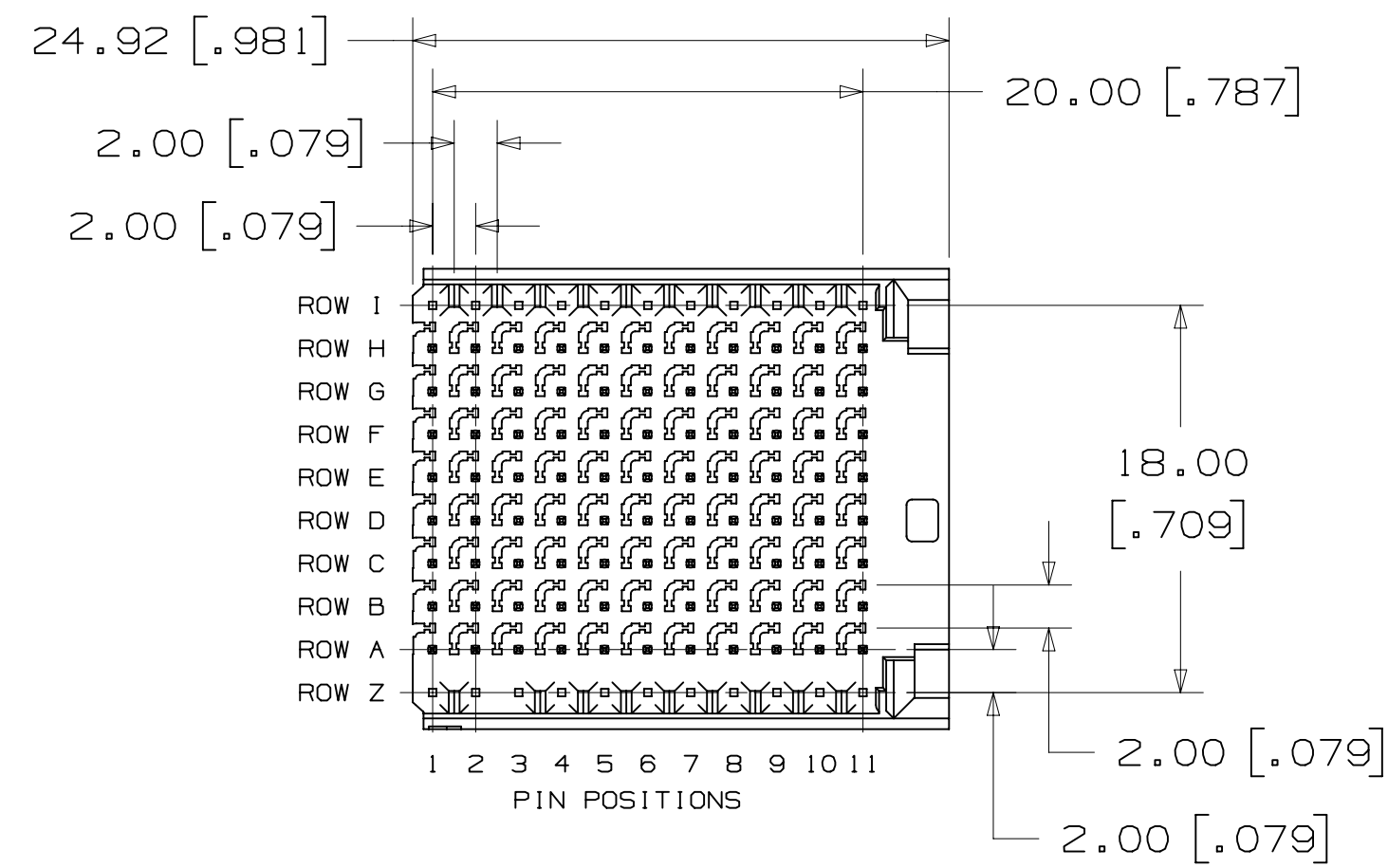

HM-H088FL1-8CX1  
HM-H110FL2-8BX1

HM-H088FR1-8CX1  
HM-H110FR2-8BXX1

DESIGN REFERENCE	NEXT ASSEMBLY	REV	ECO	ISSUE DATE AND DESCRIPTION	DRFT	CHKD
		A	39815	MAR 28, 2012	JNC	TS
DIVISION				DIVISION CODE		
Interconnect Solutions				ISD		
DO NOT SCALE DRAWING	SCALE 3/1	TOLERANCES EXCEPT AS NOTED				
THIRD ANGLE PROJECTION		INCHES				
INTERPRET PER ASME Y14.5 - 1994		MILLIMETERS				
MAX SURFACE ROUGHNESS		0				
SURFACES		.00 ± .01				
MARKED ONLY		.000 ± .005				
		.000 ± .13				
		.000 ±				
		ANGLES				
		CAGE NUMBER				
		D 78-5100-2517-0				
		MODEL				
		SHT 3 OF 4				

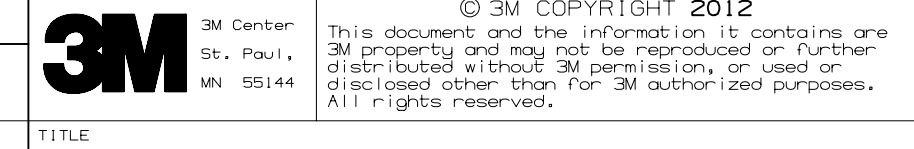

HM PRESS-FIT HEADER, 8-ROW, HM SERIES

CAGE NUMBER D 78-5100-2517-0

78-5100-2517-0  
DRAWING NUMBER

A

3M™ HM PRESS-FIT HEADER, 8-ROW, HM SERIES  
FOR HARD METRIC APPLICATIONS

HOLE	HOLE PLATING TABLE			
	(FINISHED HOLE)	Cu THICKNESS	SnPb THICKNESS	DRILLED HOLE DIA.
DIM. "B"	.690-.790 [.0270-.0310]	.025-.045 [.0010-.0018]	.008-.018 [.0003-.0007]	.810-.860 [.0320-.0340]
DIM. "D"	.550-.650 [.0217-.0256]	.025-.045 [.0010-.0018]	.008-.018 [.0003-.0007]	.686-.727 [.0270-.0286]

NOTES  
1 ROW 1 AND Z HOLES ARE ONLY USED FOR HM-HXXXX2-8BX1 STYLE HEADER.

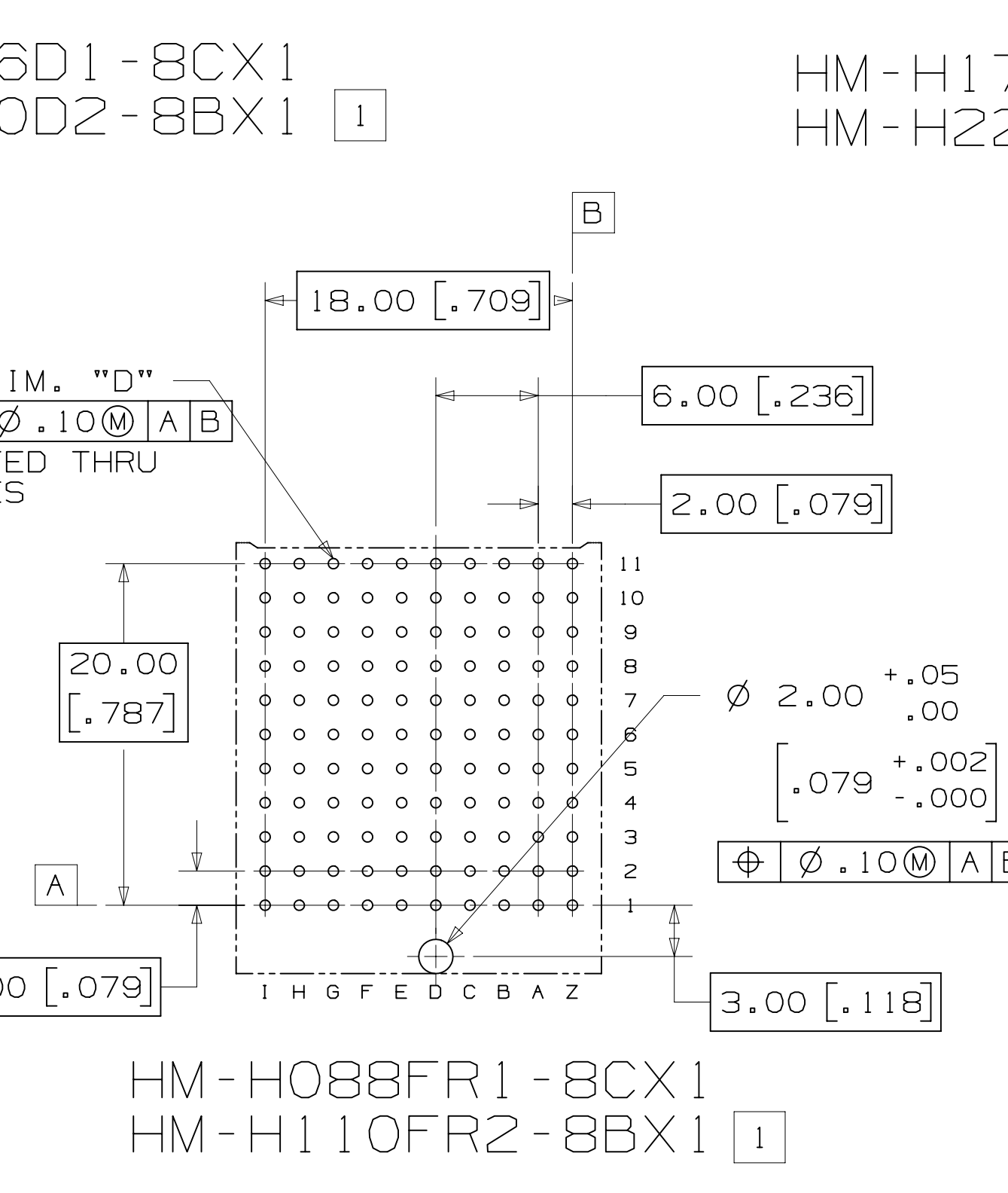
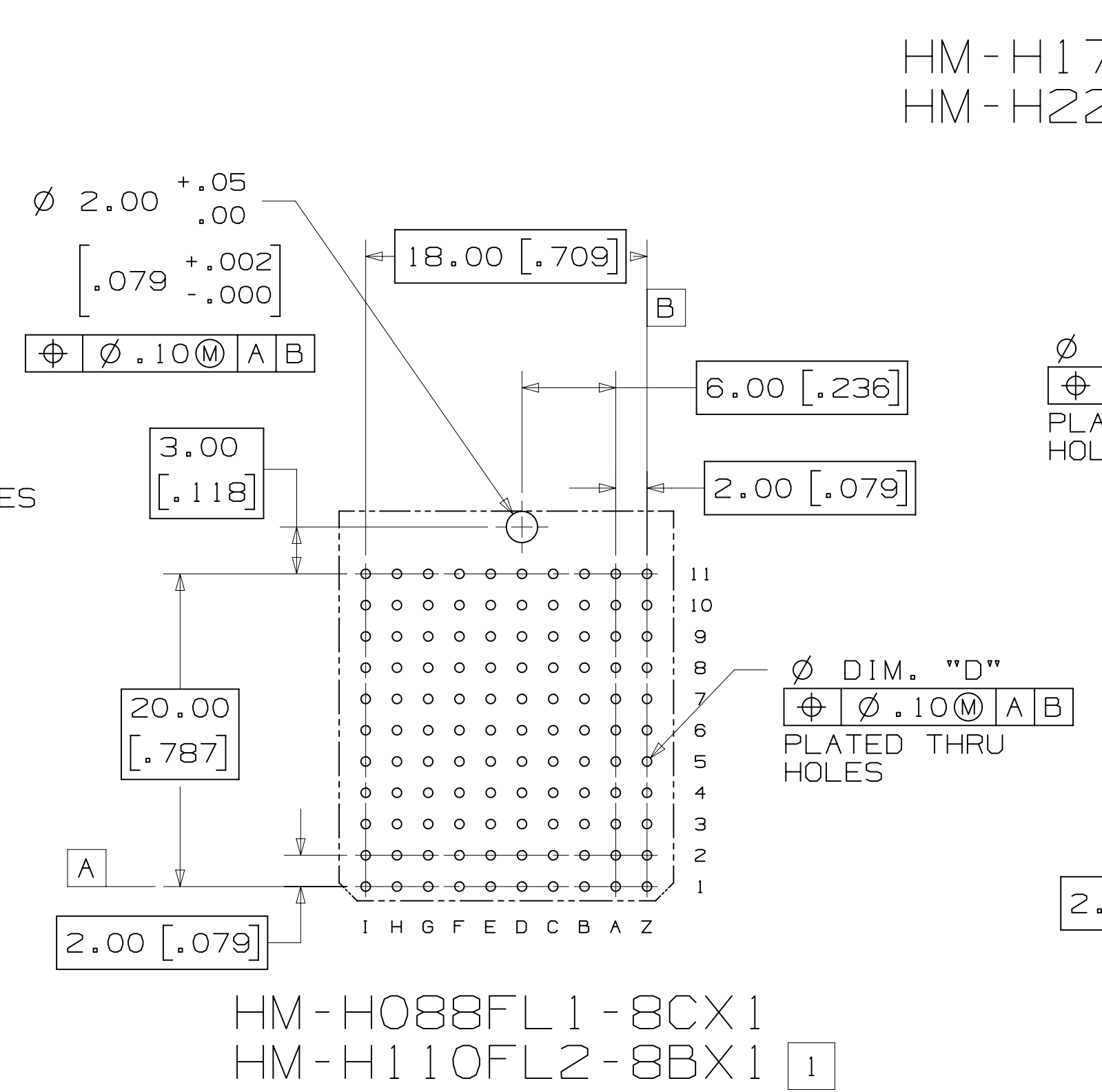
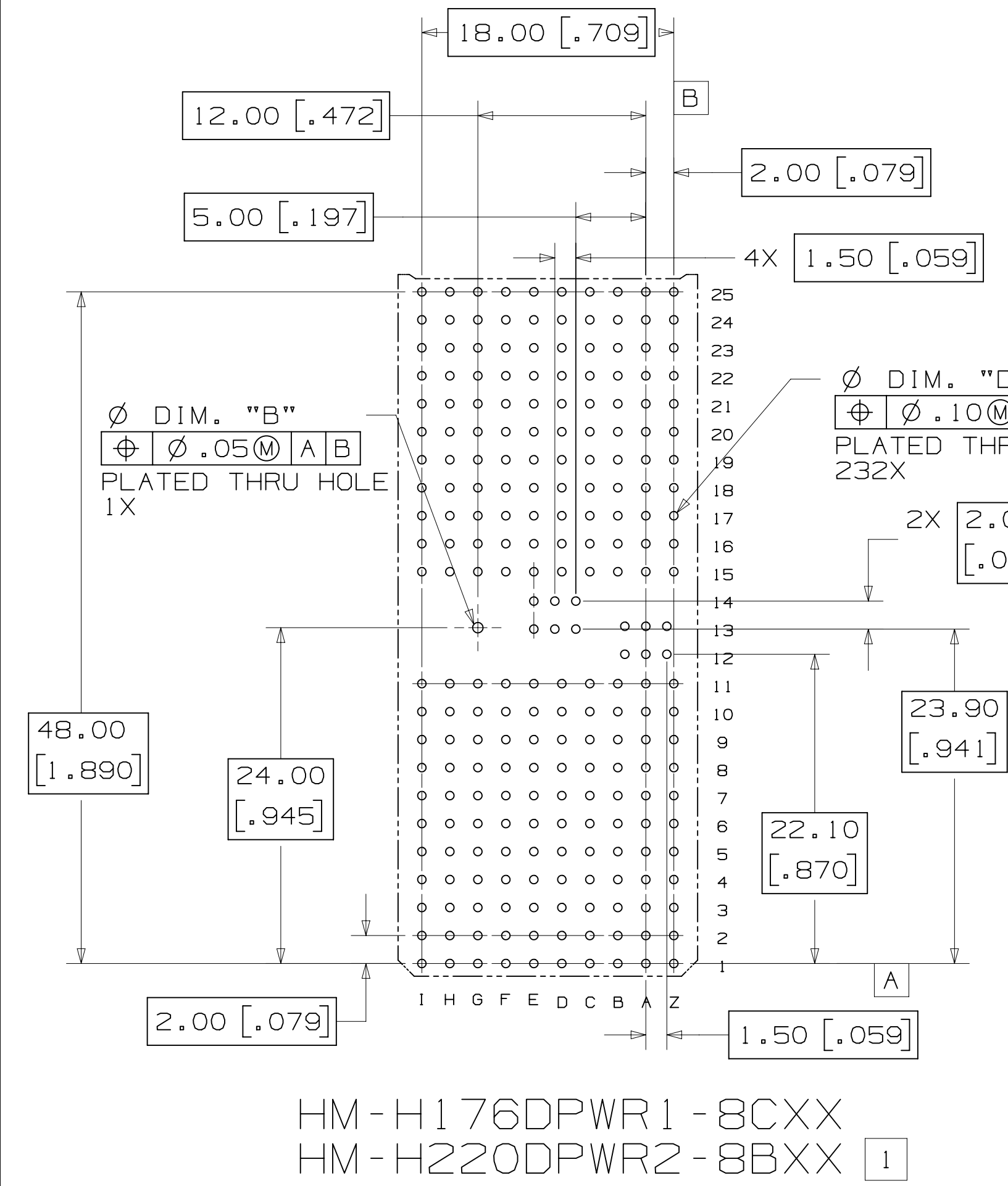
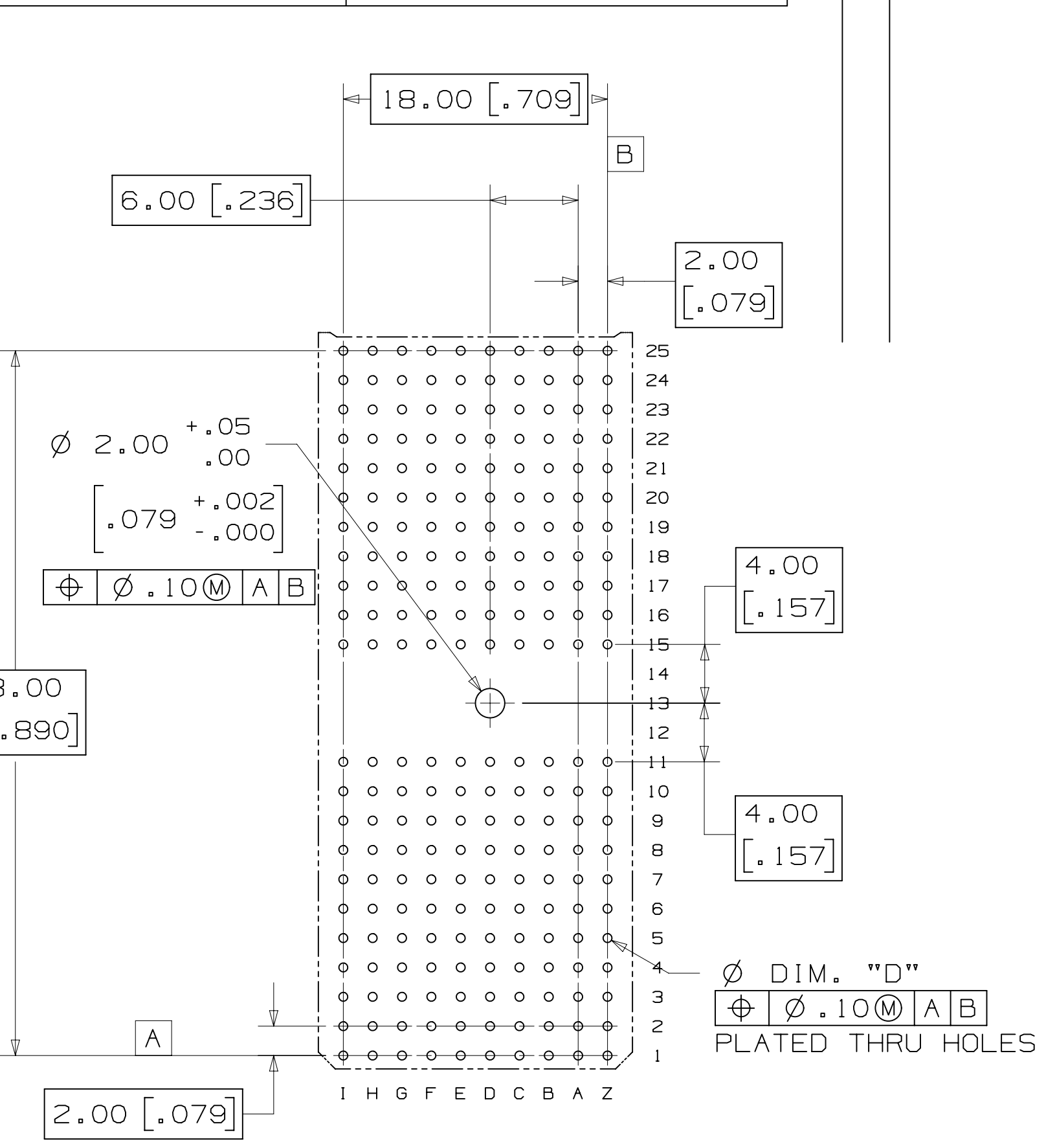
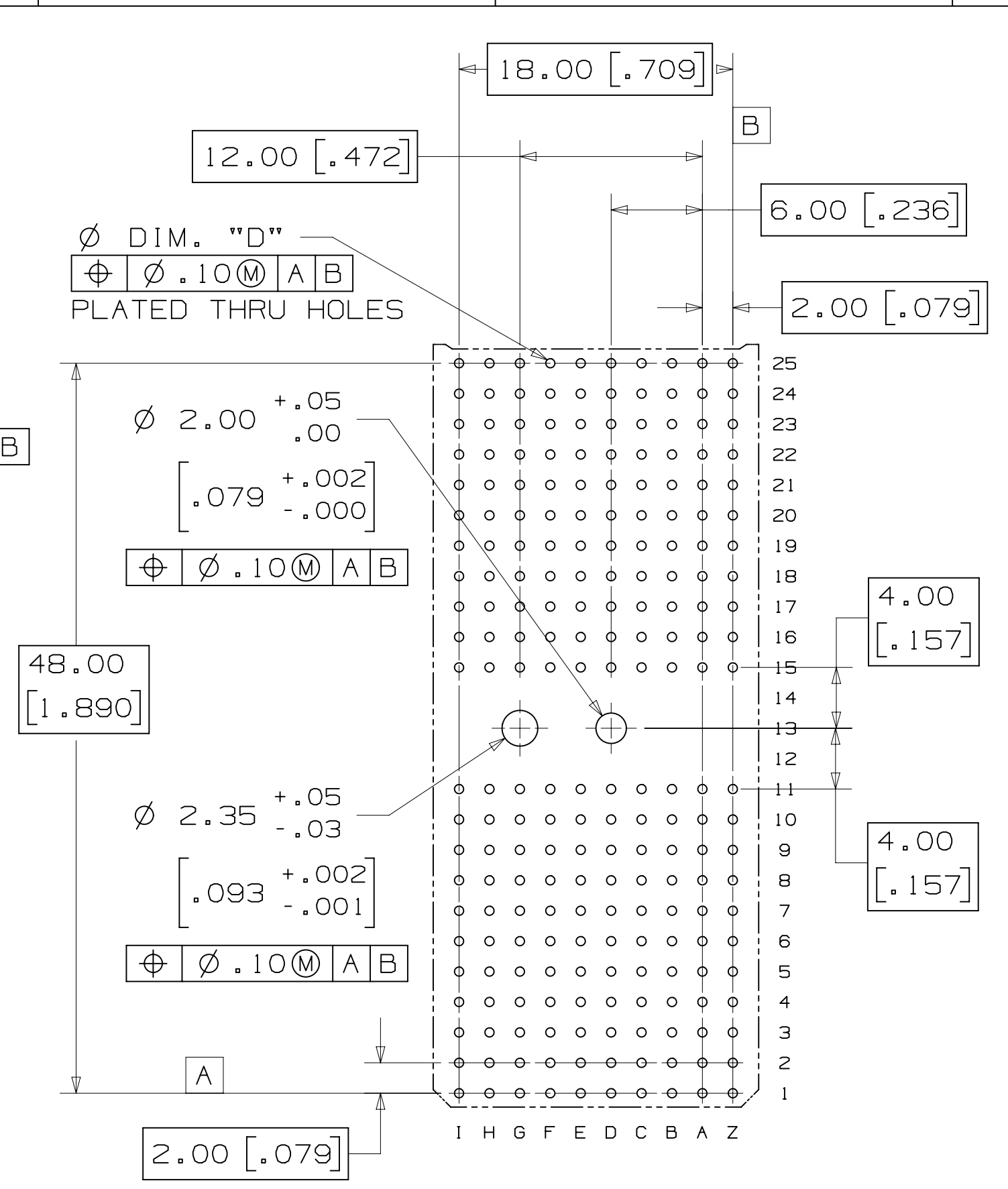
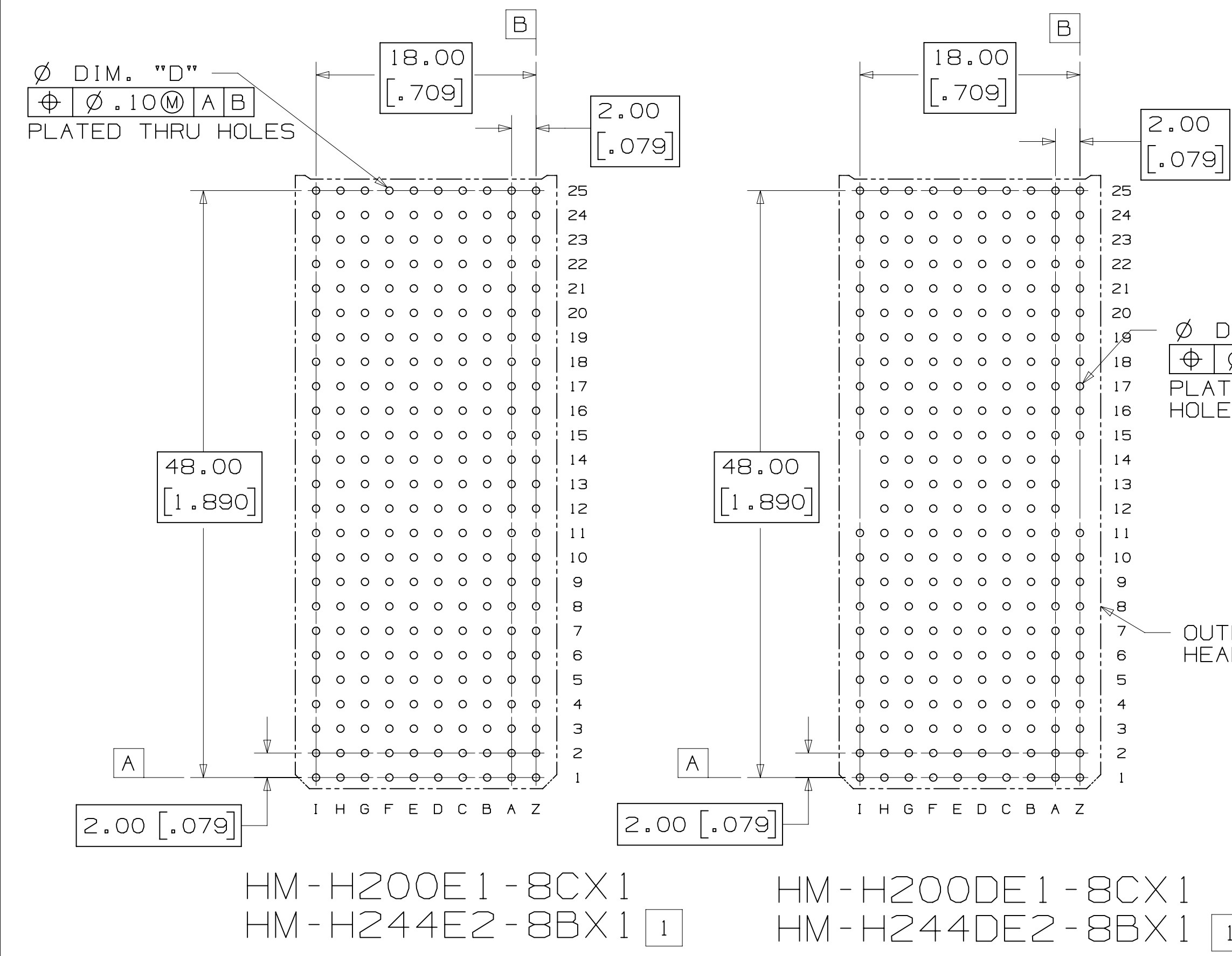

RECOMMENDED PCB MOUNTING HOLE PATTERN  
(VIEWED FROM COMPONENT SIDE)

DESIGN REFERENCE	NEXT ASSEMBLY	REV	ECO	ISSUE DATE AND DESCRIPTION	DRFT	CHKD
		A	39815	MAR 28, 2012	JNC	TS
				PRODUCTION RELEASE		
				DATE	DATE	DATE
				MAR 28, 2012		
				DATE	DATE	DATE
				MAR 28, 2012		
				DATE	DATE	DATE
				MAR 28, 2012		
				DATE	DATE	DATE
				MAR 28, 2012		

DO NOT SCALE DRAWING	SCALE	TOLERANCES EXCEPT AS NOTED
	3	
	1	

THIRD ANGLE PROJECTION	INTERPRET PER ASME Y14.5 - 1994	MAX SURFACE ROUGHNESS	MARKED SURFACES

TITLE	CAGE NUMBER	SIZE	DRAWING NO.	REV.
HM PRESS-FIT HEADER, 8-ROW, HM SERIES	D	78-5100-2517-0	A	

© 3M COPYRIGT 2012  
This document and the information it contains are 3M property and may not be reproduced or further distributed without 3M permission, or used or disclosed other than for 3M authorized purposes. All rights reserved.

MODEL  
SHT 4 OF 4



Компания «ЭлектроПласт» предлагает заключение долгосрочных отношений при поставках импортных электронных компонентов на взаимовыгодных условиях!

Наши преимущества:

- Оперативные поставки широкого спектра электронных компонентов отечественного и импортного производства напрямую от производителей и с крупнейших мировых складов;
- Поставка более 17-ти миллионов наименований электронных компонентов;
- Поставка сложных, дефицитных, либо снятых с производства позиций;
- Оперативные сроки поставки под заказ (от 5 рабочих дней);
- Экспресс доставка в любую точку России;
- Техническая поддержка проекта, помощь в подборе аналогов, поставка прототипов;
- Система менеджмента качества сертифицирована по Международному стандарту ISO 9001;
- Лицензия ФСБ на осуществление работ с использованием сведений, составляющих государственную тайну;
- Поставка специализированных компонентов (Xilinx, Altera, Analog Devices, Intersil, Interpoint, Microsemi, Aeroflex, Peregrine, Syfer, Eurofarad, Texas Instrument, Miteq, Cobham, E2V, MA-COM, Hittite, Mini-Circuits, General Dynamics и др.);

Помимо этого, одним из направлений компании «ЭлектроПласт» является направление «Источники питания». Мы предлагаем Вам помощь Конструкторского отдела:

- Подбор оптимального решения, техническое обоснование при выборе компонента;
- Подбор аналогов;
- Консультации по применению компонента;
- Поставка образцов и прототипов;
- Техническая поддержка проекта;
- Защита от снятия компонента с производства.



#### Как с нами связаться

**Телефон:** 8 (812) 309 58 32 (многоканальный)

**Факс:** 8 (812) 320-02-42

**Электронная почта:** [org@eplast1.ru](mailto:org@eplast1.ru)

**Адрес:** 198099, г. Санкт-Петербург, ул. Калинина, дом 2, корпус 4, литера А.