

## System LED Drivers for Mobile phones

# Chopper type for Flash



BD6062GU

No.11041EBT13

**●Description**

The BD6062GU is 1A Flash LED Driver ICs that can drive 1LED. It is possible to select how to control, 2wired control mode (Direct Control Mode) or 3wired mode (Register Control Mode). The BD6062GU has original Timer function in 3wired mode and easily set pre-flash timer and flash timer.

**●Features**

- 1) 400mA ~ 800mA selectable in Flash mode (Register Control Mode)
- 2) 50 ~ 200mA Torch mode (Register Control Mode)
- 3) 800mA in Flash mode (Direct control Mode)
- 4) 200mA in Torch mode (Direct control Mode)
- 5) Maximum current of LED is 1A in both Flash and Torch mode
- 6) 3Wired Mode and Direct control Mode selectable
- 7) In 3Wired Mode, Pre-Flash Timer and Flash Timer controllable
- 8) In 3Wired Mode, Flash current and Torch current is controllable
- 9) Over voltage protection
- 10) CSP 23pin Small and Thin package

**●Applications**

Flash and torch of camera for mobile phone

**●Line up matrix**

Parameter	BD6062GU
Input voltage	2.7 ~ 5.5V
Switching Frequency	480 ~ 720kHz
Maximum LED Current	1A
Package	VCSP85H2

**●Absolute maximum ratings (Ta=25°C)**

Parameter	Symbol	Ratings	Unit	Condition
Maximum applied voltage	VMAX	7	V	VBAT, VIO
Power dissipation	Pd	1100 *1	mW	
Operating temperature range	Topr	-30~+85	°C	
Storage temperature range	Tstg	-55~+150	°C	

\*1 50mm x 58mm x 1.75mm At glass epoxy board mounting. When it's used by more than Ta=25°C, it's reduced by 11mW/°C

**●Recommended operating range (Ta= -30°C ~ +85°C)**

Parameter	Symbol	Ratings			Unit	Condition
		Min.	Typ.	Max.		
Power Supply Voltage	VDD	2.7	3.6	5.5	V	*2
IO Supply Voltage	VIO	1.62	1.8	3.3	V	*2

\*2 VBAT ≥ VIO

## ●Electrical characteristics

(Unless otherwise noted, Ta = +25°C, VBAT=3.6V, VIO=1.8V)

Parameter	Symbol	Limits			Units	Condition
		Min.	Typ.	Max.		
<b>[Logic control terminal (IFMODE='L', 3wired control mode)]</b>						
Low threshold voltage1	VthL1	-	-	VIO* 0.25	V	
High threshold voltage1	VthH1	VIO* 0.75	-	-	V	
High level Input current1	IinH1	-	-	5	μA	Vin=VIO
Low level Input current1	IinL1	-5	-	-	μA	Vin=0V
<b>[Logic control terminal (IFMODE='H', Direct control mode)]</b>						
Low threshold voltage2	VthL2	-	-	0.4	V	
High threshold voltage2	VthH2	1.4	-	-	V	
High level Input current2	IinH2	-	18.3	30	μA	FLASH=TORCH=5.5V
Low level Input current2	IinL2	-2	-0.1	-	μA	FLASH=TORCH=0V
<b>[Others]</b>						
Input voltage range	Vin	3.1	-	5.5	V	VBAT input range
Quiescent Current	Iq	-	5	10	μA	Torch=Flash= OFF
Current Consumption	Idd1	-	1.8	2.5	mA	VFB=1.0V, Vin=3.6V, Torch mode
Inductor current limit	Icoil	1.5	2.0	2.5	A	Vin=3.6V *3
Switching frequency	fSW	480	600	720	kHz	
SW ON resistance	Ron	-	0.07	0.15	Ω	Iin=200mA
Duty cycle limit	Duty	60	65	-	%	VFB=0V
Output voltage range	Vo	-	-	5.4	V	
Over voltage limit	Ovl	5.4	5.5	5.6	V	VFB=0V
Start up time	Ts		0.5	1.0	ms	0mA to 200mA(Torch)
R torch terminal voltage 1	Vrt1	45	50	55	mV	Itorch[1:0]=00 (50mA)
R torch terminal voltage 2	Vrt2	90	100	110	mV	Itorch[1:0]=01 (100mA)
R torch terminal voltage 3	Vrt3	135	150	165	mV	Itorch[1:0]=10 (150mA)
R torch terminal voltage 4	Vrt4	180	200	220	mV	Itorch[1:0]=11 (200mA)
R flash terminal voltage 1	Vrf1	43	48	53	mV	Iflash[1:0]=00 (400mA)
R flash terminal voltage 2	Vrf2	54	60	66	mV	Iflash[1:0]=01 (500mA)
R flash terminal voltage 3	Vrf3	65	72	79	mV	Iflash[1:0]=10 (600mA)
R flash terminal voltage 4	Vrf4	86	96	106	mV	Iflash[1:0]=11 (800mA)

\*3 This parameter is tested with dc measurement.

●Electrical characteristic curves (Reference data)

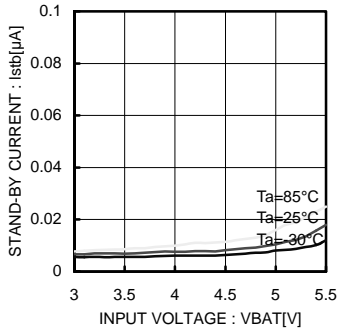

Fig.1 Quiescent current consumption (VBAT)

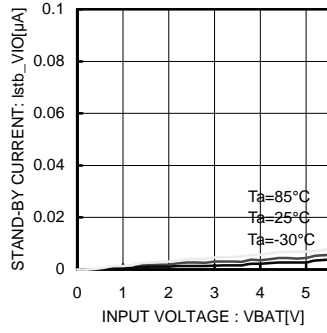

Fig.2 Quiescent current consumption (VIO)

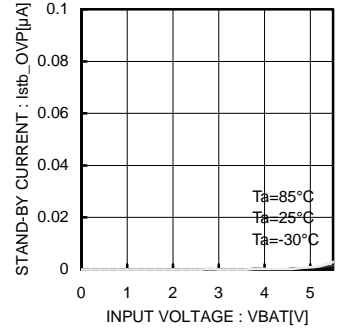

Fig.3 Quiescent current consumption (OVP)

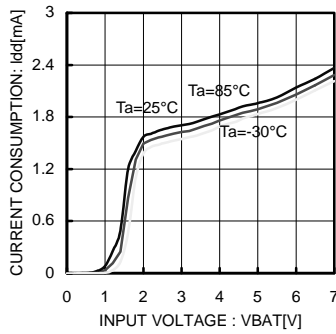

Fig.4 Current consumption (VBAT)

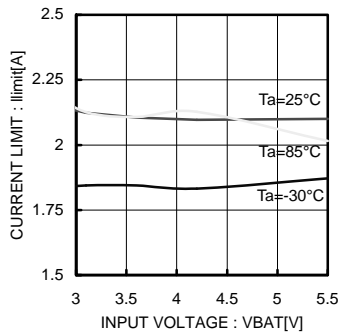

Fig.5 Over-Current Limiter

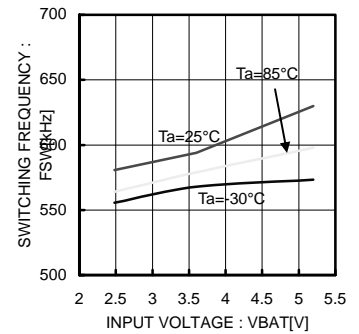

Fig.6 Switching Frequency

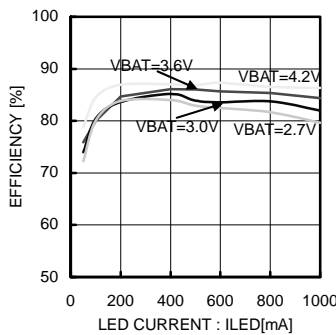

Fig.7 1A appl. Efficiency (Ta = 25°C)

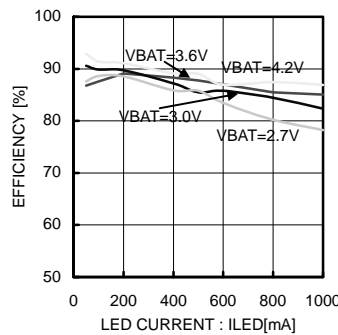

Fig.8 1A appl. Efficiency (Ta = 85°C)

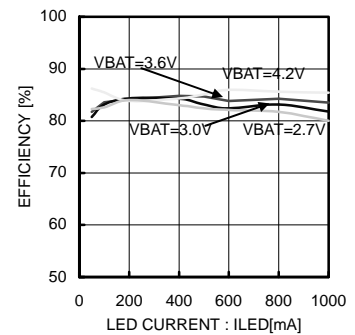

Fig.9 1A appl. Efficiency (Ta = -30°C)

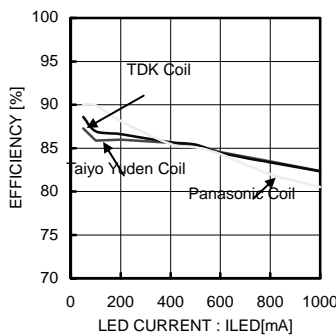

Fig.10 Each Coil Efficiency (Ta = 25°C, VBAT = 3.6V)

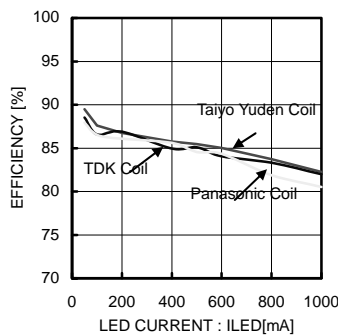

Fig.11 Each Coil Efficiency (Ta = 85°C, VBAT = 3.6V)

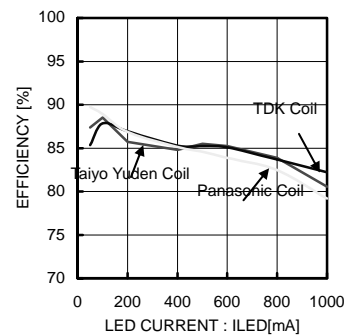

Fig.12 Each Coil Efficiency (Ta = -30°C, VBAT = 3.6V)

●Electrical characteristic curves (Reference data) – Continued

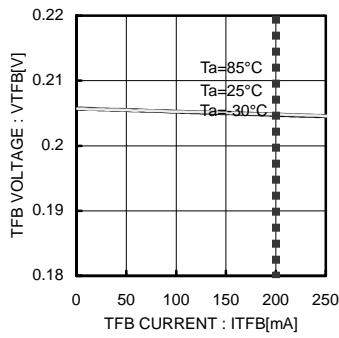

Fig.13 TORCH Load Regulation (VBAT = 5.5V)

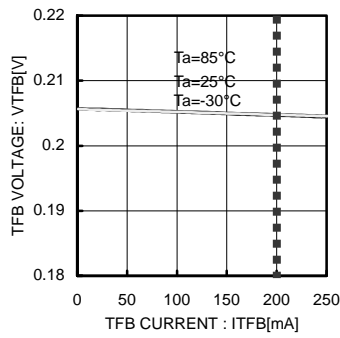

Fig.14 TORCH Load Regulation (VBAT = 3.6V)

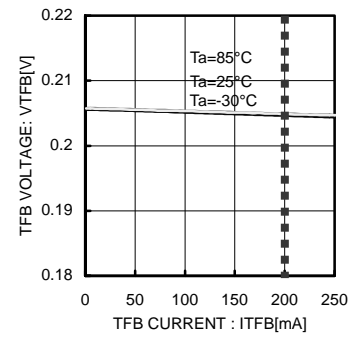

Fig.15 TORCH Load Regulation (VBAT = 2.7V)

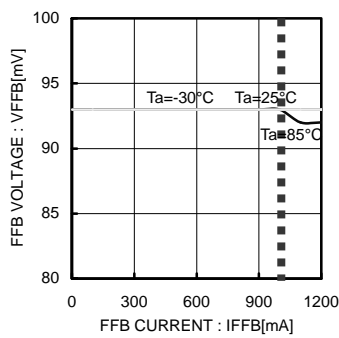

Fig.16 FLASH Load Regulation (VBAT = 5.5V)

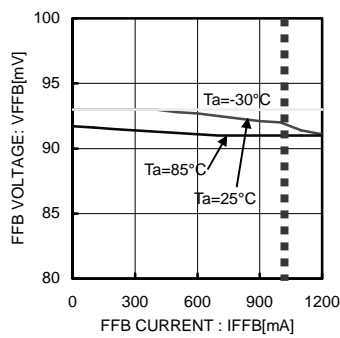

Fig.17 FLASH Load Regulation (VBAT = 3.6V)

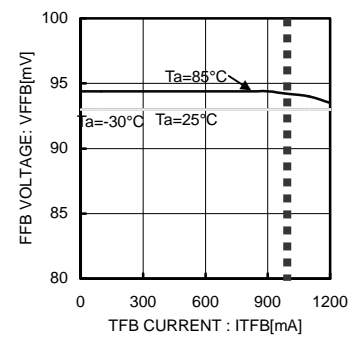

Fig.18 FLASH Load Regulation (VBAT = 2.7V)

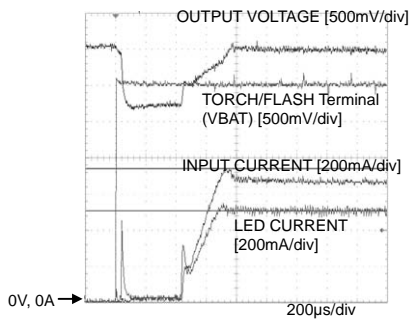

Fig.19 500mA Input rush current (VBAT=3.0V)

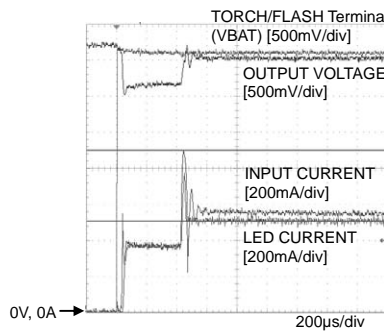

Fig.20 500mA Input rush current (VBAT=3.6V)

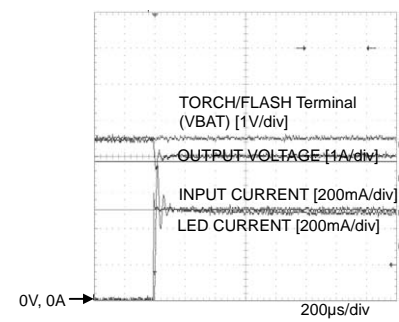

Fig.21 500mA Input rush current (VBAT=4.5V)

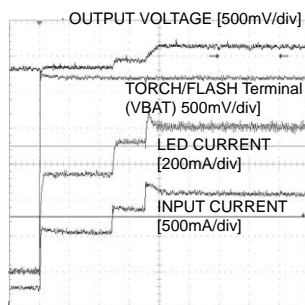

Fig.22 1A Input rush current (200mA → 1A)

●Block diagram and pin configuration

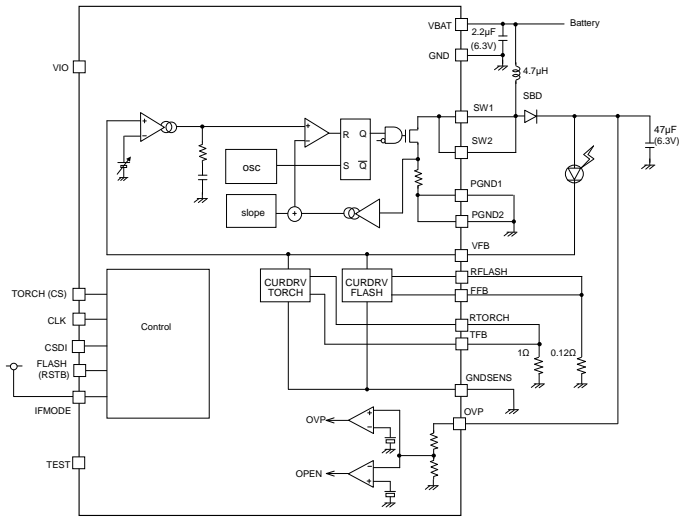

Fig.23 1A application Block diagram of Direct control Mode

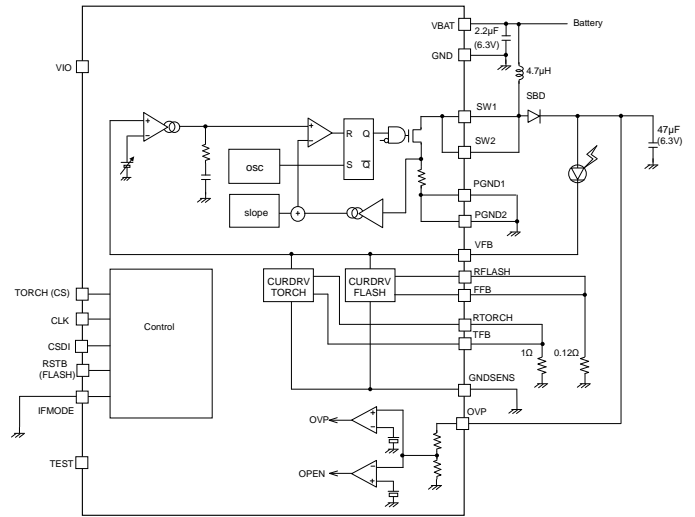

Fig.24 1A application Block diagram of 3wired control Mode

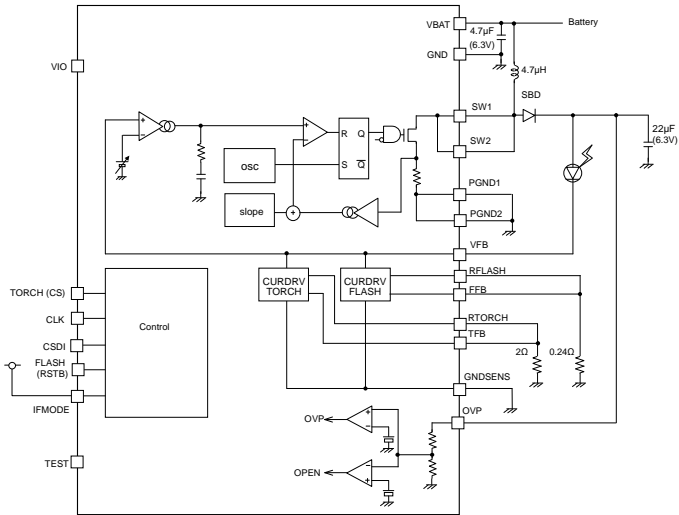

Fig.25 500mA application Block diagram of Direct control Mode

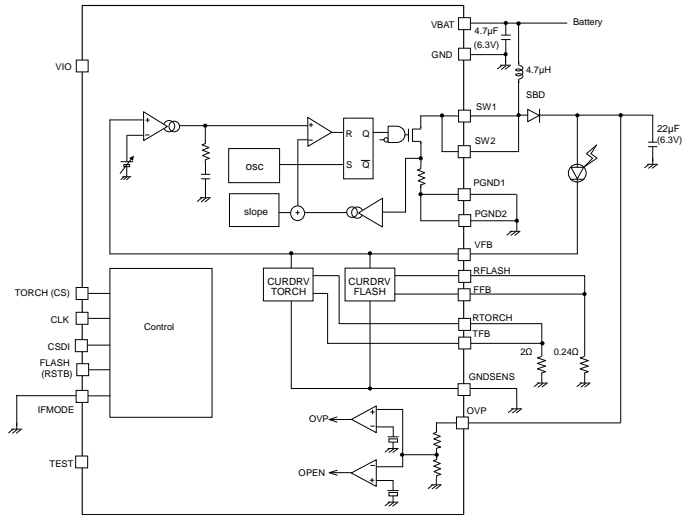

Fig.26 500mA application Block diagram of 3wired control Mode

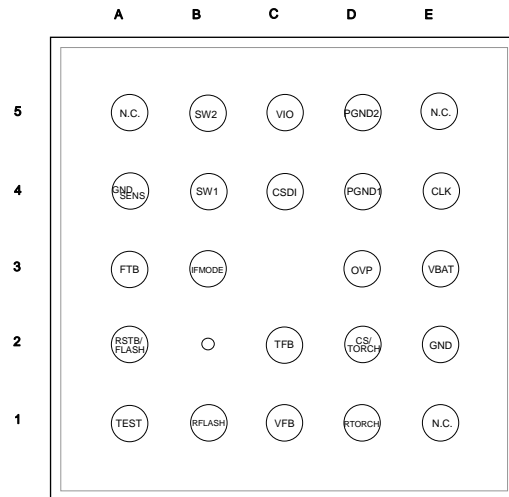

Fig.27 pin location diagram (TOP VIEW)

## ●Pin assignment table

No.	Pin Name	In/ Out	Functions
A1	TEST	In	Digital test select pin
A2	RSTB/FLASH	In	Reset ("L":Reset) (IFMODE='0') FLASH enable ("H") (IFMODE='1')
A3	FFB	In	Flash current driver feedback pin
A4	GNDSENS	In	Sense GND pin for current driver
A5	N.C	-	open
B1	RFLASH	Out	Flash current adjustment resistor pin
B3	IFMODE	In	Interface mode select
B4	SW1	In	Switching terminal 1
B5	SW2	In	Switching terminal 2
C1	VFB	In	Voltage feedback pin
C2	TFB	In	Torch current driver feedback pin
C4	CSDI	In	Data input
C5	VIO	-	I/O power supply pin
D1	RTORCH	Out	Torch current adjustment resistor pin
D2	CS/TORCH	In	Chip select (IFMODE='0') TORCH enable (IFMODE='1')
D3	OVP	In	Boost voltage feedback input pin
D4	PGND1	-	Power GND pin 1
D5	PGND2	-	Power GND pin 2
E1	N.C	-	Open
E2	GND	-	GND pin
E3	VBAT	-	Battery power supply pin
E4	CLK	In	Clock
E5	N.C	-	Open

Total : 23 Pin

## ●Description of function

## 1) CPU I/F

The Control Serial I/F provides access to Flash LED driver control registers.

Write timing show following timing chart.

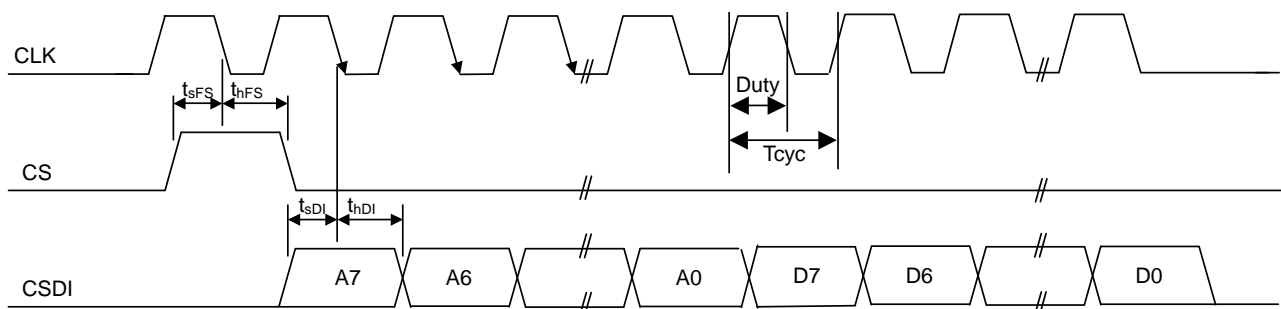

Fig.28 Control Serial Port Timing

## Control Serial Port Specifications

Parameter	Symbol	Limits			Unit	Condition
		Min.	Typ.	Max.		
CS Input Setup	$t_{sFS}$	50	-	-	ns	
CS Input Hold	$t_{hFS}$	50	-	-	ns	
CSDI Input Setup	$t_{sDI}$	50	-	-	ns	
CSDI Input Hold	$t_{hDI}$	50	-	-	ns	
Clock Cycle Time	$T_{cyc}$	133.3	-	-	ns	MAX 7.5 MHz
Duty Ratio	Duty	40	50	60	%	

Performance specifications are guaranteed, but not production tested.

## 2) Register map

Symbol	Address [7:0]	D[7]	D[6]	D[5]	D[4]	D[3]	D[2]	D[1]	D[0]
ENA	01 (H)	-	-	-	-	-	-	Flash	Torch
TIME	02 (H)	-	Tmode	Tdelay2	Tdelay1	Tdelay0	Tflash2	Tflash1	Tflash0
CURR	03 (H)	-	-	-	CLMT	Iflash1	Iflash0	Itorch1	Itorch0
TEST	04 (H)	-	-	-	-	Test3	Test2	Test1	Test0
TEST2	05 (H)	-	-	-	TEST24	TEST23	TEST22	TEST21	TEST20

\*Note: Write access is prohibited in TEST and TEST2 registers.

## Address"00(H)", Enable control

## 2-1) Enable control

Flash	Torch	Output	Default
0	0	off	*
0	1	Itorch	
1	0	Iflash	
1	1	Itorch + Iflash	

\*When IFMODE=H, each enable signal are controlled by CPU directly from Pin.

## Address"01(H)", Timer mode setting and Flash timer period control

## 2-2) Timer mode control

Tmode	Timer mode	Default
0	disable	
1	enable	*

## 2-3) Flash delay timer setting

Tdelay[2:0]	tFlash1	Default
000	0ms	*
001	5ms	
010	10ms	
011	15ms	
100	20ms	
101	25ms	
110	30ms	
111	35ms	

tFLASH1 : Flash on delay timer

It control the period from flash enable to light up.

## 2-4) Flash ON timer setting

Tflash[2:0]	TFlash2	Default
000	50ms	*
001	100ms	
010	150ms	
011	200ms	
100	400ms	
101	600ms	
110	800ms	
111	1000ms	

tFLASH2 : Flash on timer

It control the period from light up to off.

\*When IFMODE=H, it does not use timer function. Flash period is controlled by CPU directly.

Address"02(H)", Flash and Torch current setting

## 2-5) Output current setting for the Torch current driver

Itorch[1:0]	Output current	Default	IFMODE=H
00	50mA	*	
01	100mA		
10	150mA		
11	200mA		*

## 2-6) Output current setting for the Flash current driver

Iflash[1:0]	Output current	Default	IFMODE=H
00	400mA	*	
01	500mA		
10	600mA		
11	800mA		*

## 2-7) Over power protection enable

CLMT	Current Limit	Default	IFMODE=H
0	disable	*	*
1	enable		



It depends on battery or external components condition, internal power consumption will be large at flash action and there is a possibility that it will over Power dissipation of IC.

BD6062GU can limit drive current on over power condition, and protect to over Power dissipation.

When this mode is enable, BD6062GU limit maximum current automatically as below.

Torch     Max200mA → Max200mA  
Flash     Max800mA → 400mA

3) Power Control

BD6062GU can be controlled the status of activation using Enable control resistor.

4) LED drive current (Torch Mode)

The LED current is decided by the voltage of RTORCH terminal. (Rtorch=1.0Ω)

I<sub>LED</sub> is given as follows,

$$I_{LED} = I(\text{Torch Current Driver}) = V_{RTORCH} / 1.0(\Omega)$$

$$V_{RTORCH} = 0.05V, \quad R_{torch} = 1.0\Omega, \quad I_{LED} = 50mA \quad : \quad I_{torch} [1:0] = 00$$

$$V_{RTORCH} = 0.2V, \quad R_{torch} = 1.0\Omega, \quad I_{LED} = 200mA \quad : \quad I_{torch} [1:0] = 11$$

V<sub>RTORCH</sub> is controlled 0.05V~0.2V by resistor setting.

5) LED drive current (Flash Mode)

The LED current is decided by the voltage of RFLASH terminal and RTORCH terminal.

(Rflash=0.12Ω, Rtorch=1.0Ω)

I<sub>LED</sub> is given as follows,

$$I_{LED} = I(\text{Flash Current Driver}) + I(\text{Torch Current Driver}) = V_{RFLASH} / 0.12(\Omega) + V_{RTORCH} / 1.0(\Omega)$$

$$V_{RFLASH} = 0.096V, \quad R_{flash} = 0.12\Omega, \quad I_{torch}[1:0] = 11$$

$$V_{RTORCH} = 0.2V, \quad R_{torch} = 1.0\Omega, \quad I_{flash}[1:0] = 11$$

$$\left. \begin{array}{l} V_{RFLASH} = 0.096V, \quad R_{flash} = 0.12\Omega, \quad I_{torch}[1:0] = 11 \\ V_{RTORCH} = 0.2V, \quad R_{torch} = 1.0\Omega, \quad I_{flash}[1:0] = 11 \end{array} \right\} I_{LED} = 200mA + 800mA = 1000mA$$

V<sub>RFLASH</sub> is controlled 0.048V~0.096V by resistor setting.

6) Basic function

i) Register control interface(3wired) mode (timer enable)

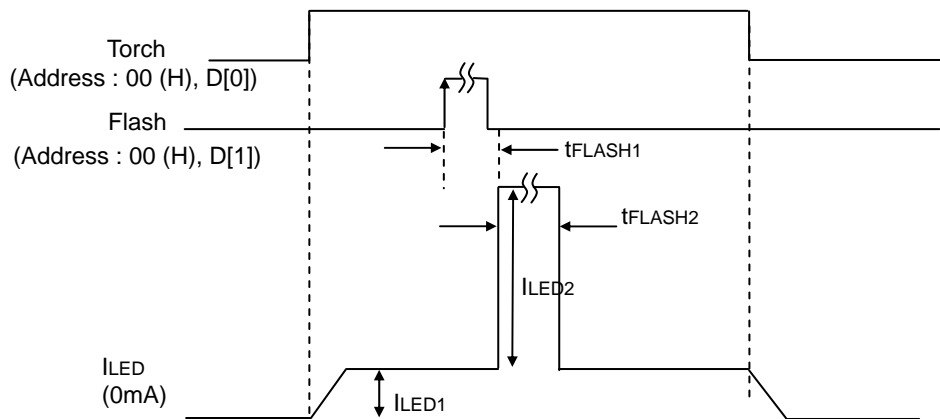

I<sub>LED1</sub> : Torch Current Driver

I<sub>LED2</sub> : Forch Current Driver

t<sub>FLASH1,2</sub> : Flash time is controlled by timer resistor setting.

Fig.29 3wired mode Torch and Flash Timing (Timer enable)

ii) Register control interface(3wired) mode (timer disable)

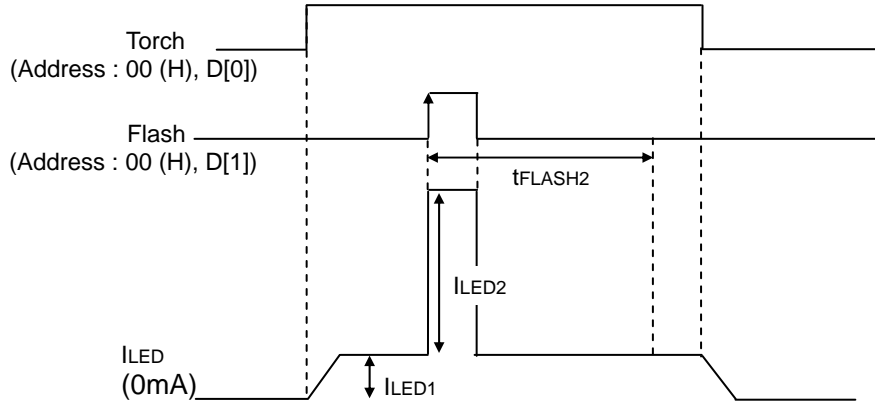

ILED1 : Torch Current Driver  
 ILED2 : Flash Current Driver  
 tFLASH2 : Flash period protect

Fig.30 3wired mode Torch and Flash Timing (Timer disable)

If flash period is over tFLASH2 setting, flash current driver will enable to turn off.  
 Protect time is controlled by flash ON timer resistor setting.

iii) Direct control interface mode

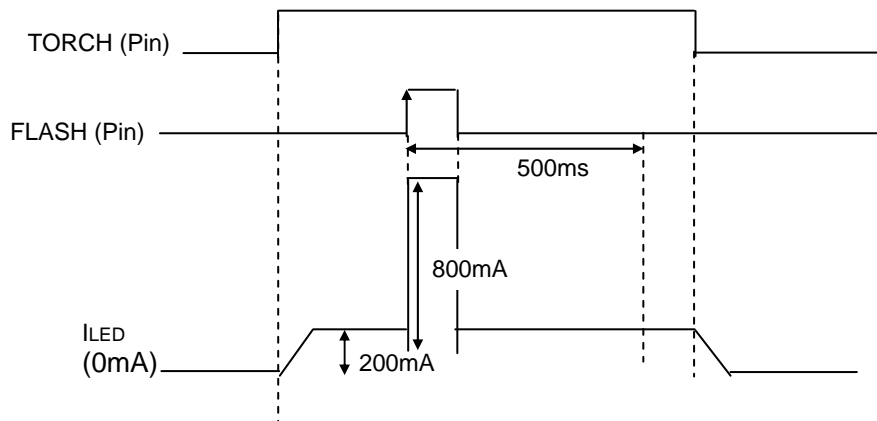

There is LED protect function in this mode.  
 Flash period is over 500ms, then this mode turn off flash.

Fig.31 Direct Control mode Torch and Flash Timing

iv) The voltage of VFB is as follows, (in DC/DC on)

- Torch mode → 350mV
- Flash mode → 350mV

7) Soft start

BD6062GU has soft start function.  
Soft start function will prevent the big peak current from IC and coil.

The detail of soft start is as follows.

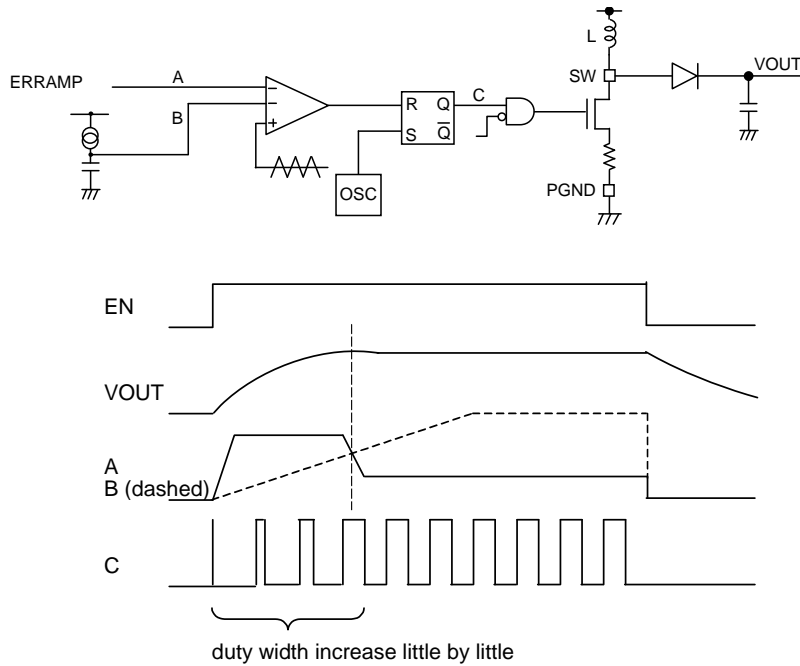

Fig.32 Soft start Diagram and Timing

8) Soft Current Limiter

BD6062GU has Soft Current Limiter function.  
Soft current limiter function will change the value of current gradually.  
It has four steps. And the steps are as follows;

4Step of soft current limiter

Action	Start	2nd step	3rd step	4th step	Normal
Time	0~500us	500~700us	700~800us	800~900us	900us~
Current Limit (DC)	0A* always	0.5A	1A	1.5A	2A
Current Limit "H (peak)	1.125A	1.75A	2.375A	3.0A	3.625A
Current Limit "L (peak)	0.675A	1.05A	1.425A	1.8A	2.175A

Peak current of BD6062GU depends on only soft current limiter.  
Switching frequency or VBAT voltage does not affect Peak current of BD6062GU.

9) Thermal shut down

BD6062GU has a thermal shut down function.  
It works above 175°C, and while, IC will change the status from active to inactive.  
When the temperature will be under 175°C, IC will return to normal operation.

## 10) Safety functions

## 10-1) Over voltage detect function (OVP)

When OVP become more than 5.5V, IC stop the switching.

When OVP become less than detect voltage, the status of switching will restart.

## 10-2) Open detect function (ODF)

When OVP pin is not connected any components, IC will stop the switching.

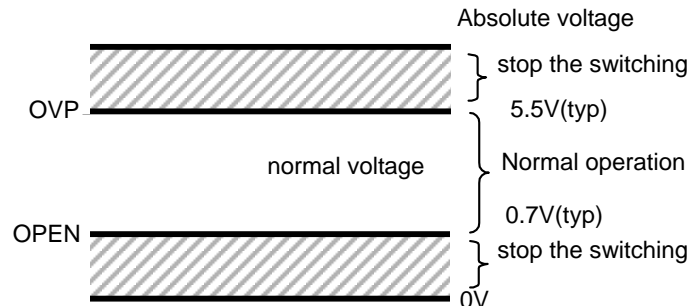

Fig.33 Safety Voltage range

## ● Selection of external parts

Recommended external parts are as shown below.

When to use other parts than these, select the following equivalent parts.

## Coil(L1)

Value	Vendor	Parts number	Size			DCR (ohm)
			X	Y	Z	
4.7 $\mu$ H	Taiyou Yuden	NR4018T4R7M	4.0	4.0	1.8	0.09
4.7 $\mu$ H	TDK	VLF3012AT-4R7MR74*	2.6	2.8	1.2	0.13

\*) for under 500mA application

## Capacitor

Value	Vendor	Parts number	Size		
			X	Y	Z
Cin					
2.2 $\mu$ F	MURATA	GRM188B30J225KE	1.6	0.8	0.8
Cout					
47 $\mu$ F	MURATA	GRM32EB31A476KE20	3.2	3.2	2.5
22 $\mu$ F	MURATA	GRM21BB30J226ME38B*	2.0	1.25	1.25

\*) for under 500mA application

## Resistance

Value	Vendor	Parts number	Size			class
			X	Y	Z	
Rflash						
0.12ohm	ROHM	MCR10EZHFLR120	2.0	1.25	0.55	$\pm 1\%$
0.24ohm	ROHM	MCR10EZHFLR240*	2.0	1.25	0.55	$\pm 1\%$
Rtorch						
1.0ohm	ROHM	MCR10EZHFL1R00	2.0	1.25	0.55	$\pm 1\%$
2.0ohm	ROHM	MCR10EZHFL2R00*	2.0	1.25	0.55	$\pm 1\%$

\*) for under 500mA application

## Shotkey Diode(D1)

VF	Vendor	Parts number	Size		
			X	Y	Z
0.43V	ROHM	RB160M-30	2.6	1.6	0.80

### ●Recommended layout pattern

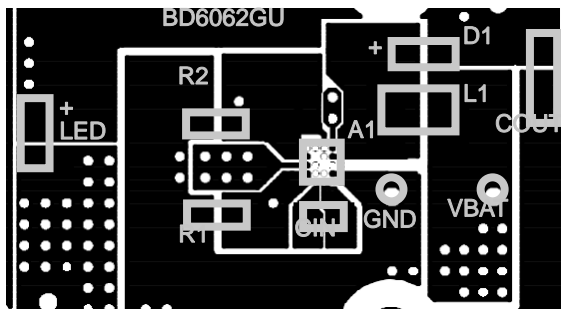

Fig.34 Frontal surface (TOP VIEW)

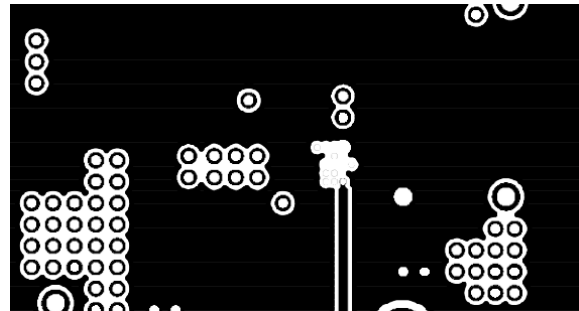

Fig.35 Middle surface1 (TOP VIEW)

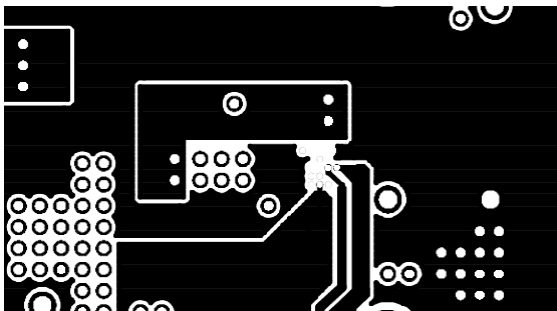

Fig.36 Middle surface2 (TOP VIEW)

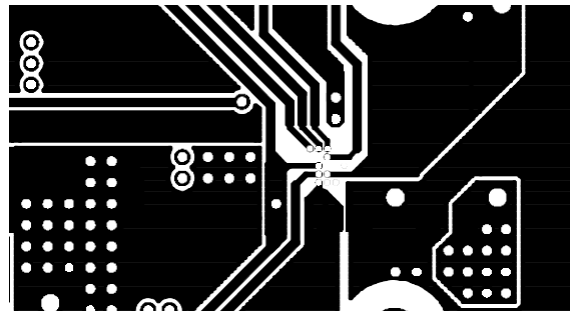

Fig.37 Rear surface (TOP VIEW)

### ●Notes for use

- (1) Absolute Maximum Ratings  
An excess in the absolute maximum ratings, such as supply voltage, temperature range of operating conditions, etc., can break down devices, thus making impossible to identify breaking mode such as a short circuit or an open circuit. If any special mode exceeding the absolute maximum ratings is assumed, consideration should be given to take physical safety measures including the use of fuses, etc.
- (2) Operating conditions  
These conditions represent a range within which characteristics can be provided approximately as expected. The electrical characteristics are guaranteed under the conditions of each parameter.
- (3) Reverse connection of power supply connector  
The reverse connection of power supply connector can break down ICs. Take protective measures against the breakdown due to the reverse connection, such as mounting an external diode between the power supply and the IC's power supply terminal.
- (4) Power supply line  
Design PCB pattern to provide low impedance for the wiring between the power supply and the GND lines. In this regard, for the digital block power supply and the analog block power supply, even though these power supplies has the same level of potential, separate the power supply pattern for the digital block from that for the analog block, thus suppressing the diffraction of digital noises to the analog block power supply resulting from impedance common to the wiring patterns. For the GND line, give consideration to design the patterns in a similar manner.  
Furthermore, for all power supply terminals to ICs, mount a capacitor between the power supply and the GND terminal. At the same time, in order to use an electrolytic capacitor, thoroughly check to be sure the characteristics of the capacitor to be used present no problem including the occurrence of capacity dropout at a low temperature, thus determining the constant.
- (5) GND voltage  
Make setting of the potential of the GND terminal so that it will be maintained at the minimum in any operating state. Furthermore, check to be sure no terminals are at a potential lower than the GND voltage including an actual electric transient.

- ( 6 ) Short circuit between terminals and erroneous mounting  
In order to mount ICs on a set PCB, pay thorough attention to the direction and offset of the ICs. Erroneous mounting can break down the ICs. Furthermore, if a short circuit occurs due to foreign matters entering between terminals or between the terminal and the power supply or the GND terminal, the ICs can break down.
- ( 7 ) Operation in strong electromagnetic field  
Be noted that using ICs in the strong electromagnetic field can malfunction them.
- ( 8 ) Inspection with set PCB  
On the inspection with the set PCB, if a capacitor is connected to a low-impedance IC terminal, the IC can suffer stress. Therefore, be sure to discharge from the set PCB by each process. Furthermore, in order to mount or dismount the set PCB to/from the jig for the inspection process, be sure to turn OFF the power supply and then mount the set PCB to the jig. After the completion of the inspection, be sure to turn OFF the power supply and then dismount it from the jig. In addition, for protection against static electricity, establish a ground for the assembly process and pay thorough attention to the transportation and the storage of the set PCB.
- ( 9 ) Input terminals  
In terms of the construction of IC, parasitic elements are inevitably formed in relation to potential. The operation of the parasitic element can cause interference with circuit operation, thus resulting in a malfunction and then breakdown of the input terminal. Therefore, pay thorough attention not to handle the input terminals, such as to apply to the input terminals a voltage lower than the GND respectively, so that any parasitic element will operate. Furthermore, do not apply a voltage to the input terminals when no power supply voltage is applied to the IC. In addition, even if the power supply voltage is applied, apply to the input terminals a voltage lower than the power supply voltage or within the guaranteed value of electrical characteristics.
- ( 10 ) Ground wiring pattern  
If small-signal GND and large-current GND are provided, It will be recommended to separate the large-current GND pattern from the small-signal GND pattern and establish a single ground at the reference point of the set PCB so that resistance to the wiring pattern and voltage fluctuations due to a large current will cause no fluctuations in voltages of the small-signal GND. Pay attention not to cause fluctuations in the GND wiring pattern of external parts as well.
- ( 11 ) External capacitor  
In order to use a ceramic capacitor as the external capacitor, determine the constant with consideration given to a degradation in the nominal capacitance due to DC bias and changes in the capacitance due to temperature, etc.
- ( 12 ) Thermal shutdown circuit (TSD)  
When junction temperatures become 175°C (typ) or higher, the thermal shutdown circuit operates and turns a switch OFF. The thermal shutdown circuit, which is aimed at isolating the LSI from thermal runaway as much as possible, is not aimed at the protection or guarantee of the LSI. Therefore, do not continuously use the LSI with this circuit operating or use the LSI assuming its operation.
- ( 13 ) Thermal design  
Perform thermal design in which there are adequate margins by taking into account the permissible dissipation (Pd) in actual states of use.
- ( 14 ) Selection of coil  
Select the low DCR inductors to decrease power loss for DC/DC converter.

●Ordering part number

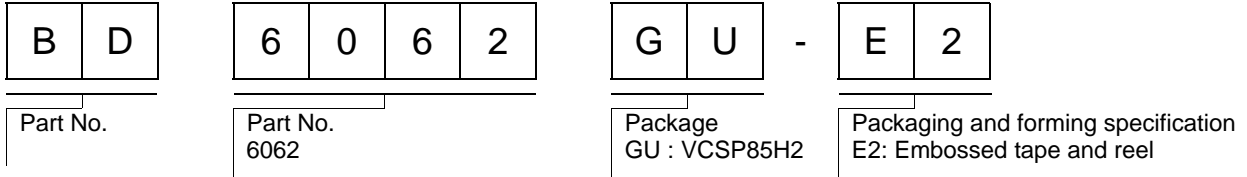

VCSP85H2 (BD6062GU)

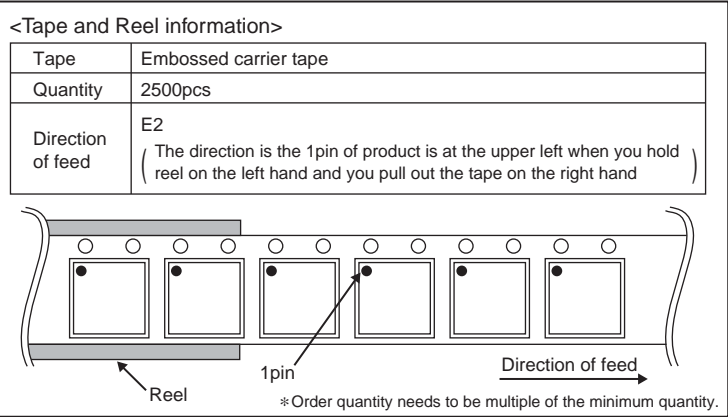
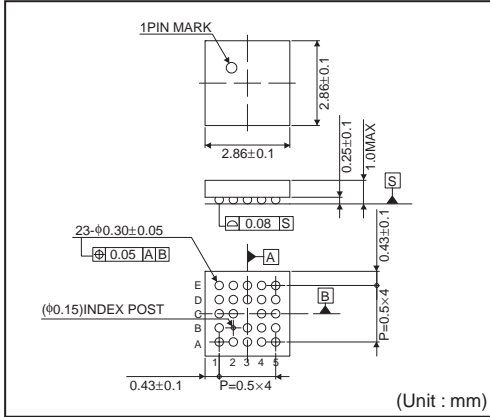

# Notice

## Precaution on using ROHM Products

- Our Products are designed and manufactured for application in ordinary electronic equipments (such as AV equipment, OA equipment, telecommunication equipment, home electronic appliances, amusement equipment, etc.). If you intend to use our Products in devices requiring extremely high reliability (such as medical equipment <sup>(Note 1)</sup>, transport equipment, traffic equipment, aircraft/spacecraft, nuclear power controllers, fuel controllers, car equipment including car accessories, safety devices, etc.) and whose malfunction or failure may cause loss of human life, bodily injury or serious damage to property ("Specific Applications"), please consult with the ROHM sales representative in advance. Unless otherwise agreed in writing by ROHM in advance, ROHM shall not be in any way responsible or liable for any damages, expenses or losses incurred by you or third parties arising from the use of any ROHM's Products for Specific Applications.

(Note1) Medical Equipment Classification of the Specific Applications

JAPAN	USA	EU	CHINA
CLASS III	CLASS III	CLASS II b	CLASS III
CLASS IV		CLASS III	

- ROHM designs and manufactures its Products subject to strict quality control system. However, semiconductor products can fail or malfunction at a certain rate. Please be sure to implement, at your own responsibilities, adequate safety measures including but not limited to fail-safe design against the physical injury, damage to any property, which a failure or malfunction of our Products may cause. The following are examples of safety measures:
  - Installation of protection circuits or other protective devices to improve system safety
  - Installation of redundant circuits to reduce the impact of single or multiple circuit failure
- Our Products are designed and manufactured for use under standard conditions and not under any special or extraordinary environments or conditions, as exemplified below. Accordingly, ROHM shall not be in any way responsible or liable for any damages, expenses or losses arising from the use of any ROHM's Products under any special or extraordinary environments or conditions. If you intend to use our Products under any special or extraordinary environments or conditions (as exemplified below), your independent verification and confirmation of product performance, reliability, etc. prior to use, must be necessary:
  - Use of our Products in any types of liquid, including water, oils, chemicals, and organic solvents
  - Use of our Products outdoors or in places where the Products are exposed to direct sunlight or dust
  - Use of our Products in places where the Products are exposed to sea wind or corrosive gases, including Cl<sub>2</sub>, H<sub>2</sub>S, NH<sub>3</sub>, SO<sub>2</sub>, and NO<sub>2</sub>
  - Use of our Products in places where the Products are exposed to static electricity or electromagnetic waves
  - Use of our Products in proximity to heat-producing components, plastic cords, or other flammable items
  - Sealing or coating our Products with resin or other coating materials
  - Use of our Products without cleaning residue of flux (even if you use no-clean type fluxes, cleaning residue of flux is recommended); or Washing our Products by using water or water-soluble cleaning agents for cleaning residue after soldering
  - Use of the Products in places subject to dew condensation
- The Products are not subject to radiation-proof design.
- Please verify and confirm characteristics of the final or mounted products in using the Products.
- In particular, if a transient load (a large amount of load applied in a short period of time, such as pulse. is applied, confirmation of performance characteristics after on-board mounting is strongly recommended. Avoid applying power exceeding normal rated power; exceeding the power rating under steady-state loading condition may negatively affect product performance and reliability.
- De-rate Power Dissipation (Pd) depending on Ambient temperature (Ta). When used in sealed area, confirm the actual ambient temperature.
- Confirm that operation temperature is within the specified range described in the product specification.
- ROHM shall not be in any way responsible or liable for failure induced under deviant condition from what is defined in this document.

## Precaution for Mounting / Circuit board design

- When a highly active halogenous (chlorine, bromine, etc.) flux is used, the residue of flux may negatively affect product performance and reliability.
- In principle, the reflow soldering method must be used; if flow soldering method is preferred, please consult with the ROHM representative in advance.

For details, please refer to ROHM Mounting specification



**Precautions Regarding Application Examples and External Circuits**

1. If change is made to the constant of an external circuit, please allow a sufficient margin considering variations of the characteristics of the Products and external components, including transient characteristics, as well as static characteristics.
2. You agree that application notes, reference designs, and associated data and information contained in this document are presented only as guidance for Products use. Therefore, in case you use such information, you are solely responsible for it and you must exercise your own independent verification and judgment in the use of such information contained in this document. ROHM shall not be in any way responsible or liable for any damages, expenses or losses incurred by you or third parties arising from the use of such information.

**Precaution for Electrostatic**

This Product is electrostatic sensitive product, which may be damaged due to electrostatic discharge. Please take proper caution in your manufacturing process and storage so that voltage exceeding the Products maximum rating will not be applied to Products. Please take special care under dry condition (e.g. Grounding of human body / equipment / solder iron, isolation from charged objects, setting of ionizer, friction prevention and temperature / humidity control).

**Precaution for Storage / Transportation**

1. Product performance and soldered connections may deteriorate if the Products are stored in the places where:
  - [a] the Products are exposed to sea winds or corrosive gases, including Cl<sub>2</sub>, H<sub>2</sub>S, NH<sub>3</sub>, SO<sub>2</sub>, and NO<sub>2</sub>
  - [b] the temperature or humidity exceeds those recommended by ROHM
  - [c] the Products are exposed to direct sunshine or condensation
  - [d] the Products are exposed to high Electrostatic
2. Even under ROHM recommended storage condition, solderability of products out of recommended storage time period may be degraded. It is strongly recommended to confirm solderability before using Products of which storage time is exceeding the recommended storage time period.
3. Store / transport cartons in the correct direction, which is indicated on a carton with a symbol. Otherwise bent leads may occur due to excessive stress applied when dropping of a carton.
4. Use Products within the specified time after opening a humidity barrier bag. Baking is required before using Products of which storage time is exceeding the recommended storage time period.

**Precaution for Product Label**

QR code printed on ROHM Products label is for ROHM's internal use only.

**Precaution for Disposition**

When disposing Products please dispose them properly using an authorized industry waste company.

**Precaution for Foreign Exchange and Foreign Trade act**

Since our Products might fall under controlled goods prescribed by the applicable foreign exchange and foreign trade act, please consult with ROHM representative in case of export.

**Precaution Regarding Intellectual Property Rights**

1. All information and data including but not limited to application example contained in this document is for reference only. ROHM does not warrant that foregoing information or data will not infringe any intellectual property rights or any other rights of any third party regarding such information or data. ROHM shall not be in any way responsible or liable for infringement of any intellectual property rights or other damages arising from use of such information or data.:
2. No license, expressly or implied, is granted hereby under any intellectual property rights or other rights of ROHM or any third parties with respect to the information contained in this document.

**Other Precaution**

1. This document may not be reprinted or reproduced, in whole or in part, without prior written consent of ROHM.
2. The Products may not be disassembled, converted, modified, reproduced or otherwise changed without prior written consent of ROHM.
3. In no event shall you use in any way whatsoever the Products and the related technical information contained in the Products or this document for any military purposes, including but not limited to, the development of mass-destruction weapons.
4. The proper names of companies or products described in this document are trademarks or registered trademarks of ROHM, its affiliated companies or third parties.

**General Precaution**

1. Before you use our Products, you are requested to carefully read this document and fully understand its contents. ROHM shall not be in any way responsible or liable for failure, malfunction or accident arising from the use of any ROHM's Products against warning, caution or note contained in this document.
2. All information contained in this document is current as of the issuing date and subject to change without any prior notice. Before purchasing or using ROHM's Products, please confirm the latest information with a ROHM sales representative.
3. The information contained in this document is provided on an "as is" basis and ROHM does not warrant that all information contained in this document is accurate and/or error-free. ROHM shall not be in any way responsible or liable for any damages, expenses or losses incurred by you or third parties resulting from inaccuracy or errors of or concerning such information.

# Mouser Electronics

Authorized Distributor

Click to View Pricing, Inventory, Delivery & Lifecycle Information:

[ROHM Semiconductor:](#)

[BD6062GU-E2](#)



Компания «ЭлектроПласт» предлагает заключение долгосрочных отношений при поставках импортных электронных компонентов на взаимовыгодных условиях!

Наши преимущества:

- Оперативные поставки широкого спектра электронных компонентов отечественного и импортного производства напрямую от производителей и с крупнейших мировых складов;
- Поставка более 17-ти миллионов наименований электронных компонентов;
- Поставка сложных, дефицитных, либо снятых с производства позиций;
- Оперативные сроки поставки под заказ (от 5 рабочих дней);
- Экспресс доставка в любую точку России;
- Техническая поддержка проекта, помощь в подборе аналогов, поставка прототипов;
- Система менеджмента качества сертифицирована по Международному стандарту ISO 9001;
- Лицензия ФСБ на осуществление работ с использованием сведений, составляющих государственную тайну;
- Поставка специализированных компонентов (Xilinx, Altera, Analog Devices, Intersil, Interpoint, Microsemi, Aeroflex, Peregrine, Syfer, Eurofarad, Texas Instrument, Miteq, Cobham, E2V, MA-COM, Hittite, Mini-Circuits, General Dynamics и др.);

Помимо этого, одним из направлений компании «ЭлектроПласт» является направление «Источники питания». Мы предлагаем Вам помощь Конструкторского отдела:

- Подбор оптимального решения, техническое обоснование при выборе компонента;
- Подбор аналогов;
- Консультации по применению компонента;
- Поставка образцов и прототипов;
- Техническая поддержка проекта;
- Защита от снятия компонента с производства.



#### Как с нами связаться

**Телефон:** 8 (812) 309 58 32 (многоканальный)

**Факс:** 8 (812) 320-02-42

**Электронная почта:** [org@eplast1.ru](mailto:org@eplast1.ru)

**Адрес:** 198099, г. Санкт-Петербург, ул. Калинина, дом 2, корпус 4, литера А.