

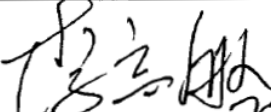

Product Specification

Product Name: VGM096032A2W03

Product Code: M01122

Customer
Approved by Customer
Approved Date:

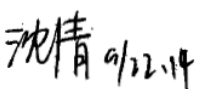
Designed By	Checked By	Approved By	
		R&D	QA
 2019.9.22	 2019.9.22	 2019.9.22	 9/22/14

CONTENT

REVISION RECORD	3
1 OVERVIEW	4
2 FEATURES	4
3 MECHANICAL DATA	4
4 MECHANICAL DRAWING	5
5 MODULE INTERFACE	6
6 FUNCTION BLOCK DIAGRAM	7
7 ABSOLUTE MAXIMUM RATINGS	8
8 ELECTRICAL CHARACTERISTICS	9
8.1 DC ELECTRICAL CHARACTERISTICS	9
8.2 ELECTRO-OPTICAL CHARACTERISTICS	10
8.3 AC ELECTRICAL CHARACTERISTICS	11
9 FUNCTIONAL SPECIFICATION AND APPLICATION CIRCUIT	17
9.1 RESET TIMING	17
9.2 APPLICATION CIRCUIT.....	18
9.3 EXTERNAL DC-DC APPLICATION CIRCUIT	23
9.4 DISPLAY CONTROL INSTRUCTION.....	24
9.5 RECOMMENDED SOFTWARE INITIALIZATION	24
10 PACKAGE SPECIFICATION	25
11 RELIABILITY	26
11.1 RELIABILITY TEST.....	26
11.2 LIFETIME.....	26
11.3 FAILURE CHECK STANDARD.....	26
11 ILLUSTRATION OF OLED PRODUCT NAME	27
12 OUTGOING QUALITY CONTROL SPECIFICATIONS	28
12.1 SAMPLING METHOD	28
12.2 INSPECTION CONDITIONS	28
12.3 QUALITY ASSURANCE ZONES.....	28
12.4 INSPECTION STANDARD.....	29
13 PRECAUTIONS FOR OPERATION AND STORAGE	32
13.1 PRECAUTIONS FOR OPERATION	32
13.2 SOLDERING	32
13.3 PRECAUTIONS FOR STORAGE.....	32
13.4 WARRANTY PERIOD.....	32

1 Overview

VGM096032A2W03 is a monochrome OLED display module with 96×32 dot matrix. The characteristics of this display module are high brightness, self-emission, high contrast ratio, slim/thin outline, wide viewing angle, wide temperature range, and low power consumption.

2 Features

- Display Color: White
- Dot Matrix:96×32
- Driver IC: SH1106G
- Interface: 8-bit 6800 8-bit 8080 I²C 4-wire SPI
- Wide range of operating temperature: -40°C to 70°C

3 Mechanical Data

NO.	ITEM	SPECIFICATION	UNIT
1	Dot Matrix	96(W)×32(H)	-
2	Dot Size	0.15(W)×0.15 (H)	mm ²
3	Dot Pitch	0.17 (W)×0.17 (H)	mm ²
4	Aperture Rate	78	%
5	Active Area	16.3(W)×5.42(H)	mm ²
6	Panel Size	19.8(W)×12.8(H)×1.05(T)	mm ³
7	Module Size	19.8(W)×37.8(H)×1.28 (T)	mm ³
8	Diagonal A/A Size	0.68	inch
9	Module Weight	0.63 ± 10%	gram

4 Mechanical Drawing

如本印章非红色, 则表明该文件为非受控版本, 不会受到控制和更新. 请使用受控文件.
受控章
分发号:

Specification

1. Display: OLED (White)
2. Format: 96*32
3. Driver IC: SH106G
4. General Tolerance: ± 0.3
5. Operate temp: $-40^{\circ}\text{C} \sim 70^{\circ}\text{C}$
6. Storage temp: $-40^{\circ}\text{C} \sim 85^{\circ}\text{C}$
7. RoHS Compliant

Customer Approval Signature	Part Name	Module Ass'y	Date	Rev.	Unit	Sheet
	Project Code	01122	2014.06.04	02	mm	1/1
	Part No.	01122-MA1-A	DES' D BY	CHK' D BY	CHK' D BY	APPROVED

Rev.	Date	Note
①	2014.05.27	Based on M01120: Modify the PFC
②	2014.06.04	Modify the dimension

Pin Assignment NO.	SYMBOL
1	VSS
2	C1N
3	C1P
4	C2P
5	C2N
6	VDD2
7	VDD1
8	IM1
9	IM2
10	CSB
11	RESB
12	A0
13	WRB
14	RDB
15	D0
16	D1
17	D2
18	D3
19	D4
20	D5
21	D6
22	D7
23	IRFP
24	VCOMH
25	VPP

5 Module Interface

PIN NO.	PIN NAME	DESCRIPTION															
1	VSS	Ground.															
2	C1N	Connect to charge pump capacitor.															
3	C1P	These pins are not used and should be disconnected when VPP is supplied externally.															
4	C2P	Connect to charge pump capacitor.															
5	C2N	These pins are not used and should be disconnected when VPP is supplied externally.															
6	VDD2	3.0 – 4.2V power supply pad for Power supply for charge pump circuit. This pin can be disconnected or connect to VDD1 when VPP is supplied externally.															
7	VDD1	Power supply input: 1.65 - 3.5V															
8	IM1	<table border="1"> <thead> <tr> <th>Pin Name</th> <th>I²C</th> <th>6800</th> <th>8080</th> <th>4-SPI</th> </tr> </thead> <tbody> <tr> <td>IM1</td> <td>1</td> <td>0</td> <td>1</td> <td>0</td> </tr> <tr> <td>IM2</td> <td>0</td> <td>1</td> <td>1</td> <td>0</td> </tr> </tbody> </table>	Pin Name	I ² C	6800	8080	4-SPI	IM1	1	0	1	0	IM2	0	1	1	0
Pin Name	I ² C	6800	8080	4-SPI													
IM1	1	0	1	0													
IM2	0	1	1	0													
9	IM2																
10	CSB	This pad is the chip select input. When CSB = “L”, then the chip select becomes active, and data/command I/O is enabled.															
11	RESB	This is a reset signal input pad. When RESB is set to “L”, the settings are initialized. The reset operation is performed by the RESB signal level.															
12	A0	This is the Data/Command control pad that determines whether the data bits are data or a command. A0 = “H”: the inputs at D0 to D7 are treated as display data. A0 = “L”: the inputs at D0 to D7 are transferred to the command registers. In I ² C interface, this pad serves as SA0 to distinguish the different address of OLED driver.															
13	WRB	This is a MPU interface input pad. When connected to an 8080 MPU, this is active LOW. This pad connects to the 8080 MPU WRB signal. The signals on the data bus are latched at the rising edge of the WRB signal. When connected to a 6800 Series MPU: This is the read/write control signal input terminal. When WRB = “H”: Read. When WRB = “L”: Write.															
14	RDB	This is a MPU interface input pad. When connected to an 8080 series MPU, it is active LOW. This pad is connected to the RDB signal of the 8080 series MPU, and the data bus is in an output status when this signal is “L”. When connected to a 6800 series MPU, this is active HIGH. This is used as an enable clock input of the 6800 series MPU. When RDB = “H”: Enable. When RDB = “L”: Disable.															
15~22	D0~D7	This is an 8-bit bi-directional data bus that connects to an 8-bit or 16-bit standard MPU data bus. When the serial interface is selected, then D0 serves as the serial clock input pad (SCL) and D1 serves as the serial data input pad (SI). At this time, D2 to D7 are set to high impedance. When the I ² C interface is selected, then D0 serves as the serial clock input pad (SCL) and D1 serves as the serial data input pad (SDAI). At this time, D2 to D7 are set to high impedance.															
23	IREF	This is a segment current reference pad. A resistor should be connected between this pad and VSS. Set the current at 12.5 μ A.															
24	VCOMH	This is a pad for the voltage output high level for common signals. A capacitor should be connected between this pad and VSS.															
25	VPP	OLED panel power supply. Generated by internal charge pump. Connect to capacitor. It could be supplied externally.															

6 Function Block Diagram

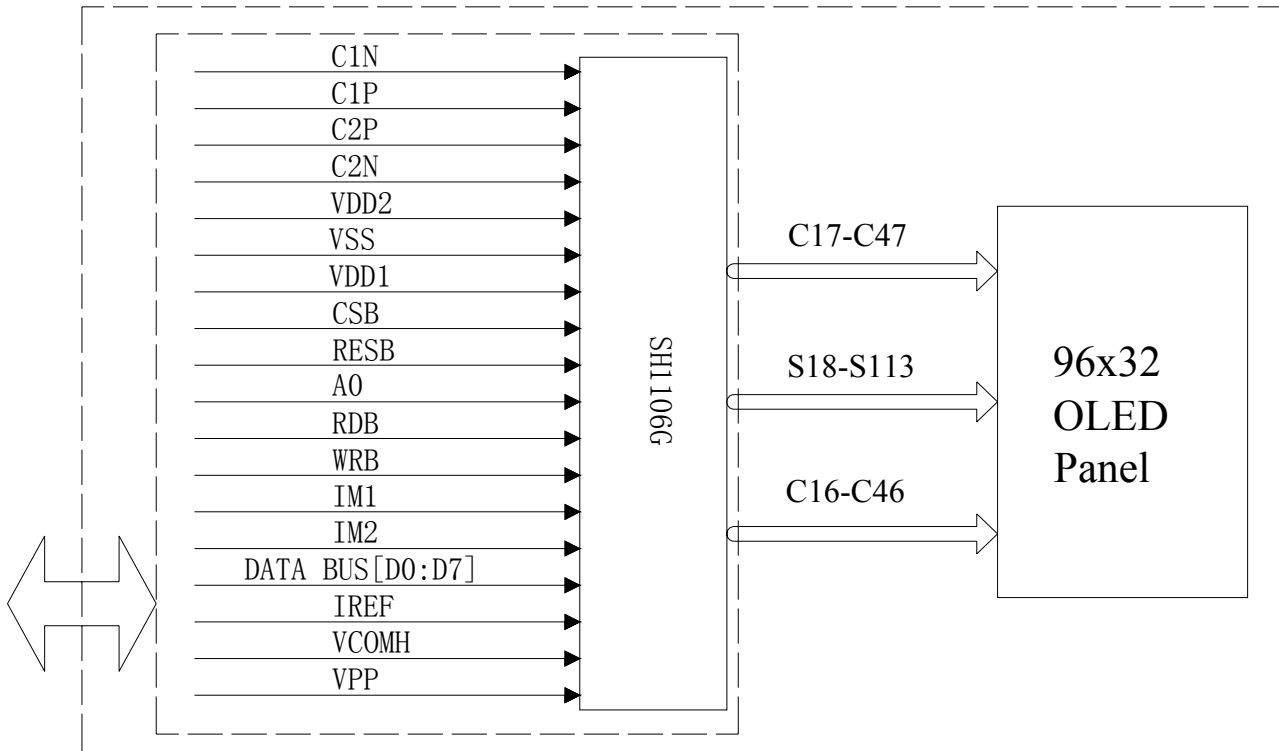

7 Absolute Maximum Ratings

ITEM	SYMBOL	MIN	MAX	UNIT	REMARK
Logic supply voltage	VDD1	-0.3	3.6	V	IC maximum rating
Charge Pump Regulator Supply Voltage	VDD2	-0.3	4.3	V	IC maximum rating
OLED Operating voltage	VPP	-0.3	14.5	V	IC maximum rating
Operating Temp.	Top	-40	70	°C	-
Storage Temp	Tstg	-40	85	°C	-

Note (1): All of the voltages are on the basis of “VSS = 0V”.

Note (2): Permanent breakage of module may occur if the module is used beyond the maximum rating. The module can be normal operated under the conditions according to Section 8 “Electrical Characteristics”. Malfunctioning of the module may occur and the reliability of the module may deteriorate if the module is used beyond the conditions.

8 Electrical Characteristics

8.1 DC Electrical Characteristics

ITEM	SYMBOL	TEST CONDITION	MIN	TYP	MAX	UNIT
Logic Supply Voltage	VDD1	22±3°C, 55±15%R.H	1.65	3.0	3.5	V
OLED Driver Supply Voltage (Generated by Internal DC/DC)	VPP	22±3°C, 55±15%R.H	-	8.0	-	V
Charge Pump Regulator Supply Voltage	VDD2	22±3°C, 55±15%R.H	3.0	3.7	4.2	V
High-level Input Voltage	V _{IH}	-	0.8×VDD1	-	VDD1	V
Low-level Input Voltage	V _{IL}	-	VSS	-	0.2×VDD1	V
High-level Output Voltage	V _{OH}	-	0.8×VDD1	-	VDD1	V
Low-level Output Voltage	V _{OL}	-	VSS	-	0.2×VDD1	V

Note : The VPP input must be kept in a stable value; ripple and noise are not allowed.

8.2 Electro-optical Characteristics

ITEM	SYMBOL	TEST CONDITION	MIN	TYP	MAX	UNIT
Normal Mode Brightness	L _{br}	All pixels ON(1) (VPP generated by internal DC/DC)	120	150	-	cd/m ²
Normal Mode Power Consumption	Pt	All pixels ON(1) (VPP generated by internal DC/DC)	-	55.5	66.6	mW
Sleep mode current consumption in VDD1 & VDD2	ISP	During sleep, TA = +25°C, VDD1 = 3V, VDD2 = 3V. (2)	-	-	10	uA
Sleep mode current consumption in VPP		During sleep, TA = +25°C, VPP = 9V (External)	-	-	10	uA
C.I.E(White)	(x)	x,y(CIE1931)	0.26	0.30	0.34	-
	(y)		0.29	0.33	0.37	-
Dark Room Contrast	CR	-	≥2000:1	-	-	-
Response Time	-	-	-	10	-	μ s
View Angle	-	-	≥160	-	-	Degree

Note(1): Normal Mode test conditions are as follows:

- Driving voltage : VDD2:3.7V(VPP Generated by Internal DC/DC).
- Contrast setting : 0x58
- Frame rate : 104Hz
- Duty setting : 1/32

Note(2): Sleep Mode test conditions are as follows:

- Disable Charge Pump:0XAD,0X8A.
- Set Display OFF:0XAE ,

When the display OFF command is executed, power saver mode will be entered.

Sleep mode:

This mode stops every operation of the OLED display system, and can reduce current consumption nearly to a static current value if no access is made from the microprocessor. The internal status in the sleep mode is as follows:

- Stops the oscillator circuit and DC-DC circuit.
- Stops the OLED drive and outputs HZ as the segment/common driver output.
- Holds the display data and operation mode provided before the start of the sleep mode.
- The MPU can access to the built-in display RAM.

8.3 AC Electrical Characteristics

(1) System buses Read/Write characteristics 1 (For the 8080 Series Interface MPU)

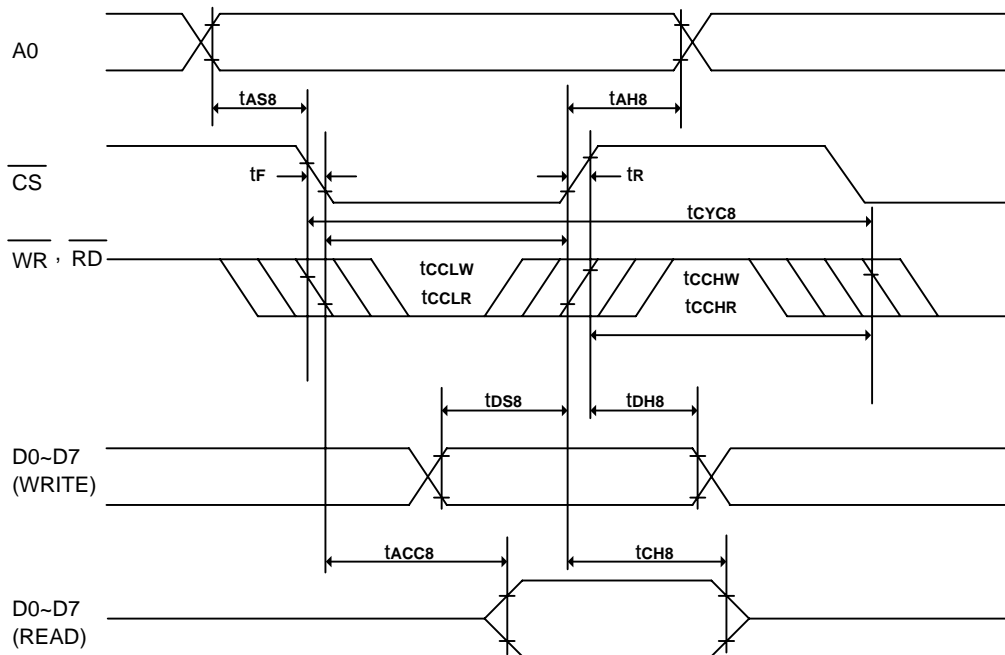

(VDD1 = 1.65 - 3.5V, TA = +25°C)

Symbol	Parameter	Min	Typ	Max	Unit	Condition
t_{CYC8}	System cycle time	600	-	-	ns	
t_{AS8}	Address setup time	0	-	-	ns	
t_{AH8}	Address hold time	0	-	-	ns	
t_{DS8}	Data setup time	80	-	-	ns	
t_{DH8}	Data hold time	30	-	-	ns	
t_{CH8}	Output disable time	20	-	140	ns	$C_L = 100pF$
t_{ACC8}	\overline{RD} access time	-	-	280	ns	$C_L = 100pF$
t_{cCLW}	Control L pulse width (WR)	200	-	-	ns	
t_{cCLR}	Control L pulse width (RD)	240	-	-	ns	
t_{cCHW}	Control H pulse width (WR)	200	-	-	ns	
t_{cCHR}	Control H pulse width (RD)	200	-	-	ns	
t_r	Rise time	-	-	30	ns	
t_f	Fall time	-	-	30	ns	

(VDD1 = 2.4 - 3.5V, T_A = +25°C)

Symbol	Parameter	Min	Typ	Max	Unit	Condition
t _{CYC8}	System cycle time	300	-	-	ns	
t _{AS8}	Address setup time	0	-	-	ns	
t _{AH8}	Address hold time	0	-	-	ns	
t _{DS8}	Data setup time	40	-	-	ns	
t _{DH8}	Data hold time	15	-	-	ns	
t _{CH8}	Output disable time	10	-	70	ns	C _L = 100pF
t _{ACC8}	\overline{RD} access time	-	-	140	ns	C _L = 100pF
t _{CCLW}	Control L pulse width (WR)	100	-	-	ns	
t _{CCLR}	Control L pulse width (RD)	120	-	-	ns	
t _{CCHW}	Control H pulse width (WR)	100	-	-	ns	
t _{CCHR}	Control H pulse width (RD)	100	-	-	ns	
t _R	Rise time	-	-	15	ns	
t _F	Fall time	-	-	15	ns	

(2) System buses Read/Write Characteristics 2 (For the 6800 Series Interface MPU)

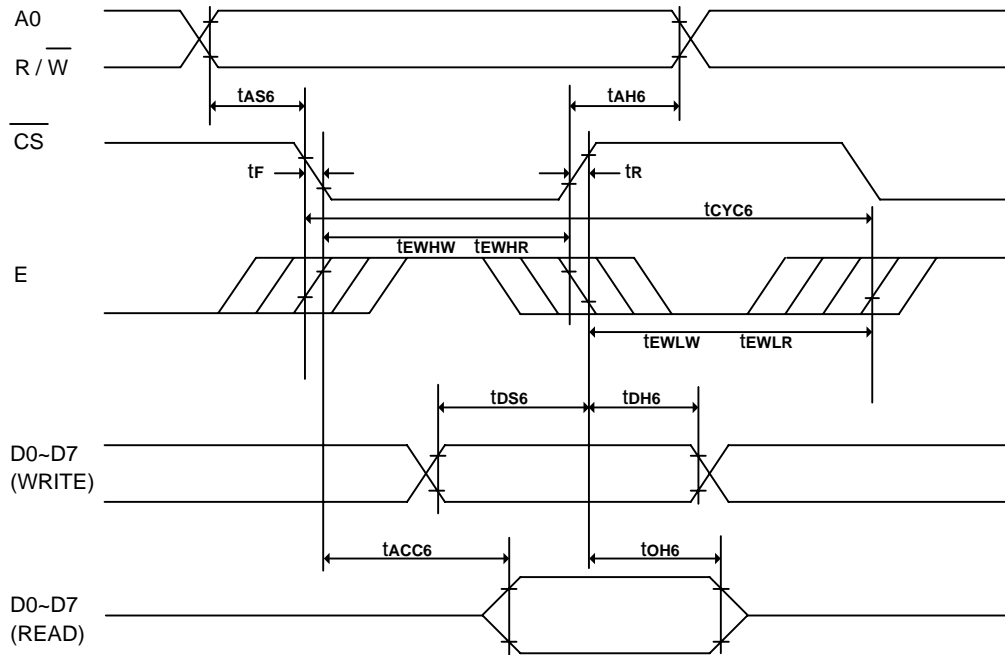

(VDD1 = 1.65 - 3.5V, TA = +25°C)

Symbol	Parameter	Min	Typ	Max	Unit	Condition
t_{CYC6}	System cycle time	600	-	-	ns	
t_{AS6}	Address setup time	0	-	-	ns	
t_{AH6}	Address hold time	0	-	-	ns	
t_{DS6}	Data setup time	80	-	-	ns	
t_{DH6}	Data hold time	30	-	-	ns	
t_{OH6}	Output disable time	20	-	140	ns	$C_L = 100pF$
t_{ACC6}	Access time	-	-	280	ns	$C_L = 100pF$
t_{EWHW}	Enable H pulse width (Write)	200	-	-	ns	
t_{EWHR}	Enable H pulse width (Read)	240	-	-	ns	
t_{EWLW}	Enable L pulse width (Write)	200	-	-	ns	
t_{EWLR}	Enable L pulse width (Read)	200	-	-	ns	
t_{TR}	Rise time	-	-	30	ns	
t_{TF}	Fall time	-	-	30	ns	

(VDD1 = 2.4 - 3.5V, T_A = +25°C)

Symbol	Parameter	Min	Typ	Max	Unit	Condition
t _{CYC6}	System cycle time	300	-	-	ns	
t _{AS6}	Address setup time	0	-	-	ns	
t _{AH6}	Address hold time	0	-	-	ns	
t _{DS6}	Data setup time	40	-	-	ns	
t _{DH6}	Data hold time	15	-	-	ns	
t _{OH6}	Output disable time	10	-	70	ns	C _L = 100pF
t _{ACC6}	Access time	-	-	140	ns	C _L = 100pF
t _{EWHW}	Enable H pulse width (Write)	100	-	-	ns	
t _{EWHR}	Enable H pulse width (Read)	120	-	-	ns	
t _{EWLW}	Enable L pulse width (Write)	100	-	-	ns	
t _{EWLR}	Enable L pulse width (Read)	100	-	-	ns	
t _R	Rise time	-	-	15	ns	
t _F	Fall time	-	-	15	ns	

(3) System buses Write characteristics 3(For the Serial Interface MPU)

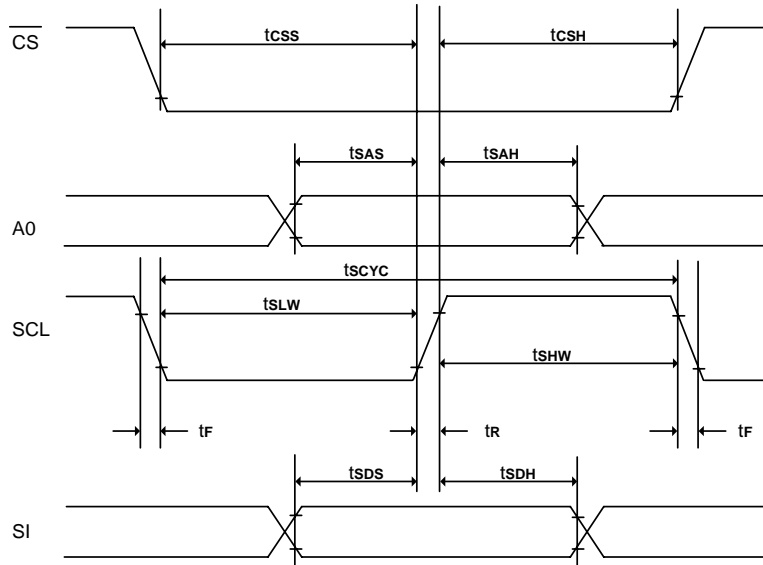

(VDD1 = 1.65 - 3.5V, TA = +25°C)

Symbol	Parameter	Min	Typ	Max	Unit	Condition
tSCYC	Serial clock cycle	500	-	-	ns	
tsAS	Address setup time	300	-	-	ns	
tsAH	Address hold time	300	-	-	ns	
tSDS	Data setup time	200	-	-	ns	
tSDH	Data hold time	200	-	-	ns	
tCSS	\overline{CS} setup time	240	-	-	ns	
tCSH	\overline{CS} hold time time	120	-	-	ns	
tSHW	Serial clock H pulse width	200	-	-	ns	
tSLW	Serial clock L pulse width	200	-	-	ns	
tr	Rise time	-	-	30	ns	
tf	Fall time	-	-	30	ns	

(VDD1 = 2.4 - 3.5V, TA = +25°C)

Symbol	Parameter	Min	Typ	Max	Unit	Condition
tSCYC	Serial clock cycle	250	-	-	ns	
tsAS	Address setup time	150	-	-	ns	
tsAH	Address hold time	150	-	-	ns	
tSDS	Data setup time	100	-	-	ns	
tSDH	Data hold time	100	-	-	ns	
tCSS	\overline{CS} setup time	120	-	-	ns	
tCSH	\overline{CS} hold time time	60	-	-	ns	
tSHW	Serial clock H pulse	100	-	-	ns	
tSLW	Serial clock L pulse	100	-	-	ns	
tr	Rise time	-	-	15	ns	
tf	Fall time	-	-	15	ns	

(4) I²C interface characteristics

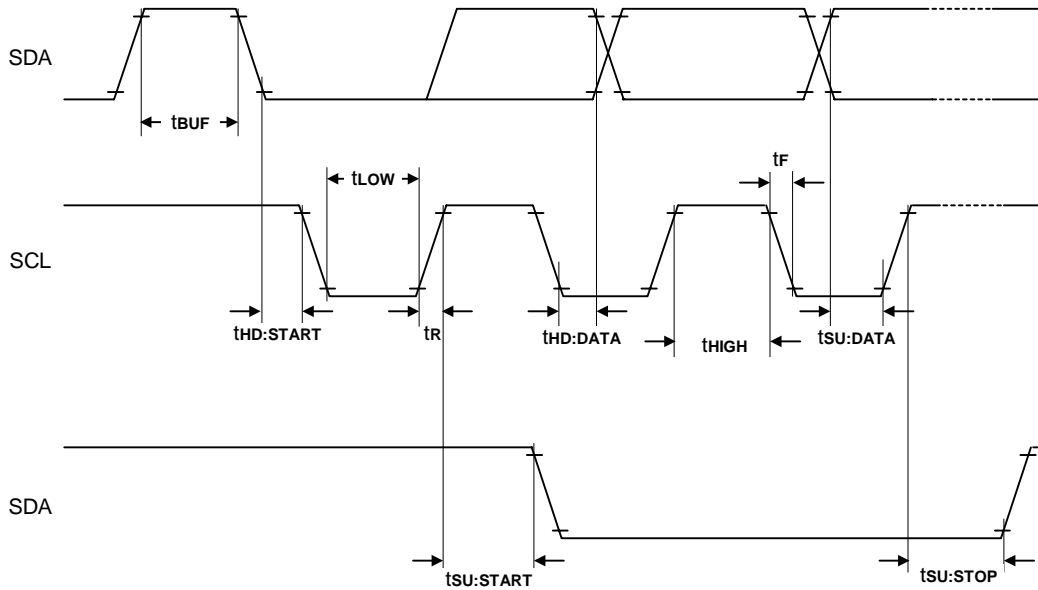

(VDD1 = 1.65 - 3.5V, TA = +25°C)

Symbol	Parameter	Min	Typ	Max	Unit	Condition
f _{SCL}	SCL clock frequency	DC	-	400	kHz	
T _{LOW}	SCL clock Low pulse width	1.3	-	-	uS	
T _{HIGH}	SCL clock H pulse width	0.6	-	-	uS	
T _{SU:DATA}	data setup time	100	-	-	nS	
T _{HD:DATA}	data hold time	0	-	0.9	uS	
T _R	SCL , SDA rise time	20+0.1Cb	-	300	nS	
T _F	SCL , SDA fall time	20+0.1Cb	-	300	nS	
C _b	Capacity load on each bus line	-	-	400	pF	
T _{SU:START}	Setup time for re-START	0.6	-	-	uS	
T _{HD:START}	START Hold time	0.6	-	-	uS	
T _{SU:STOP}	Setup time for STOP	0.6	-	-	uS	
T _{BUF}	Bus free times between STOP and START condition	1.3	-	-	uS	

9 Functional Specification and Application Circuit

9.1 Reset Timing

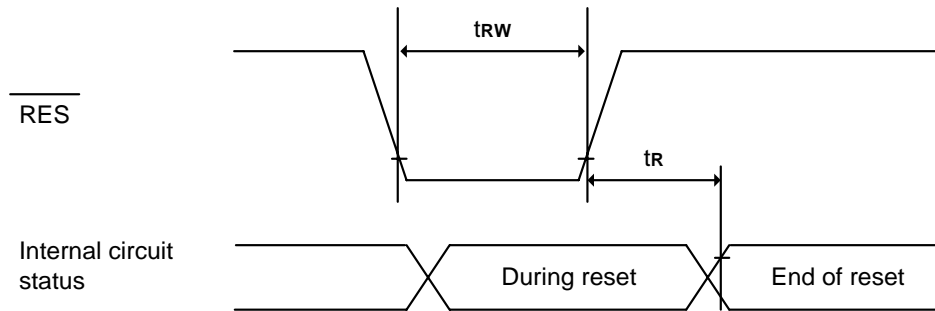

(VDD1 = 1.65 - 3.5V, T_A = +25°C)

Symbol	Parameter	Min.	Typ.	Max.	Unit	Condition
t _R	Reset time	-	-	2.0	μs	
t _{rw}	Reset low pulse width	10.0	-	-	μs	

(VDD1 = 2.4 - 3.5V, T_A = +25°C)

Symbol	Parameter	Min.	Typ.	Max.	Unit	Condition
t _R	Reset time	-	-	1.0	μs	
t _{rw}	Reset low pulse width	5.0	-	-	μs	

9.2 Application Circuit

9.2.1 Under external VPP Mode, the charge Pump Setting (ADh) must be set as follow:

ADh: Charge Pump Setting 8Ah: Disable Charge Pump

(1). The configuration for 8080-parallel interface mode, external VPP is shown in the following diagram:

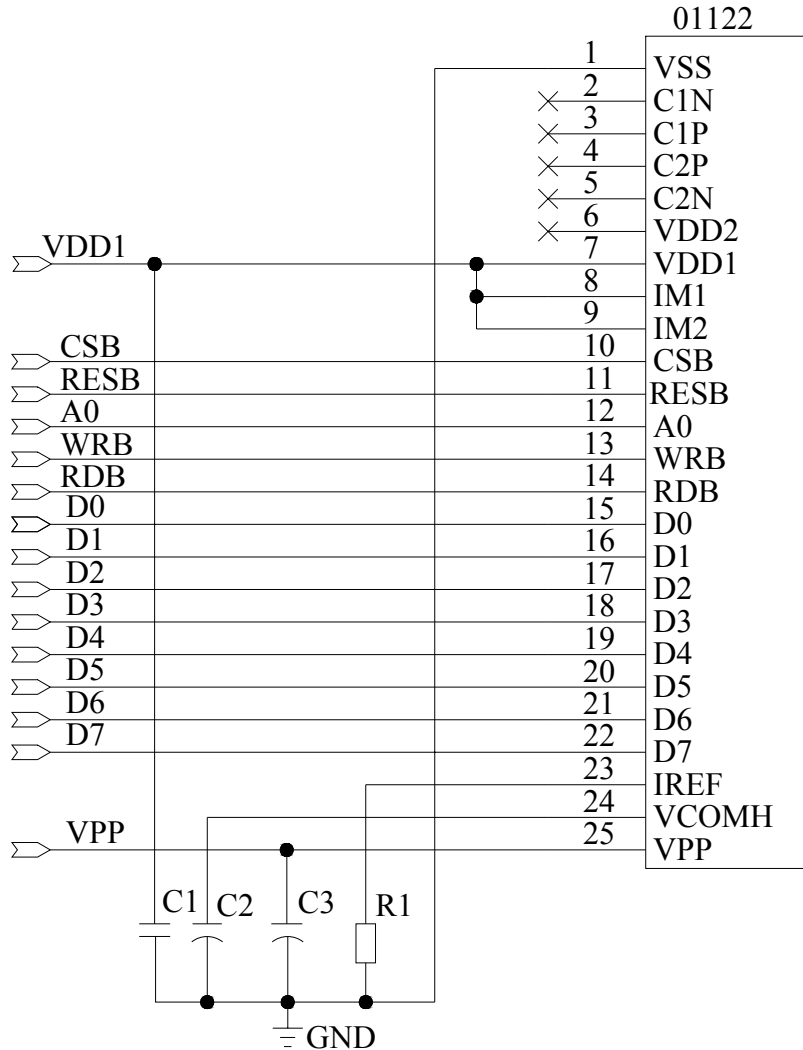

Pin connected to MCU interface: D[0:7],RDB, WRB, A0,RESB , CSB

Recommended components

C1: 1uF-0603-X7R±10%.RoHS

C2,C3 : 4.7μF/25V.RoHS (Tantalum Capacitors)

R1: 0603 1/10W +/-5% 390K ohm.RoHS

(2).The configuration for 6800-parallel interface mode, external VPP is shown in the following diagram:

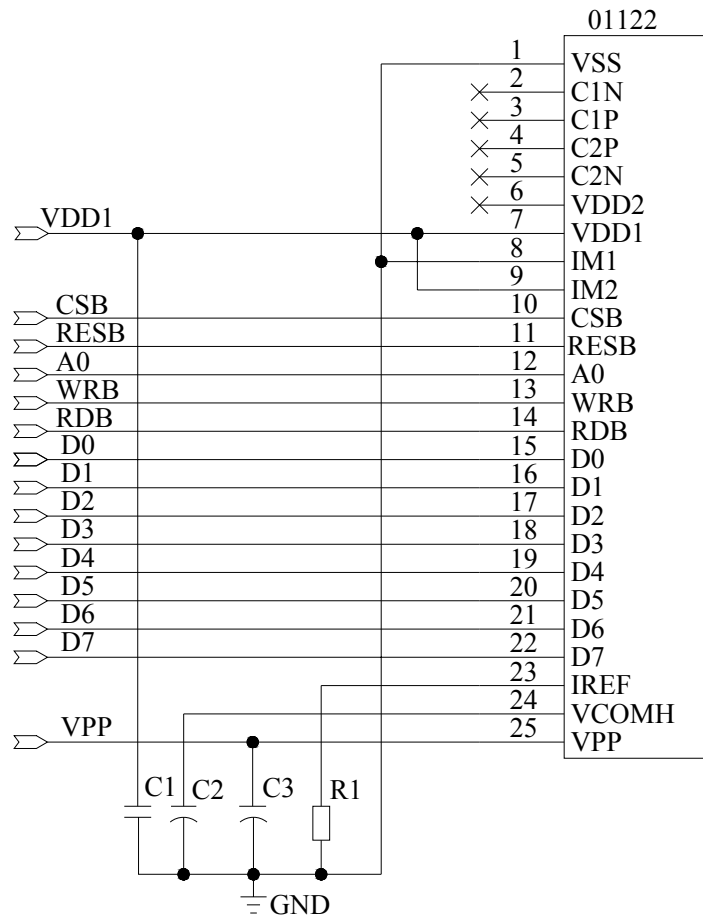

Pin connected to MCU interface: D[0:7],RDB, WRB, A0,RESB , CSB

Recommended components

C1: 1uF-0603-X7R±10%.RoHS

C2,C3 : 4.7µF/25V.RoHS (Tantalum Capacitors)

R1: 0603 1/10W +/-5% 390K ohm.RoHS

(3).The configuration for 4-wire SPI interface mode, external VPP is shown in the following diagram:

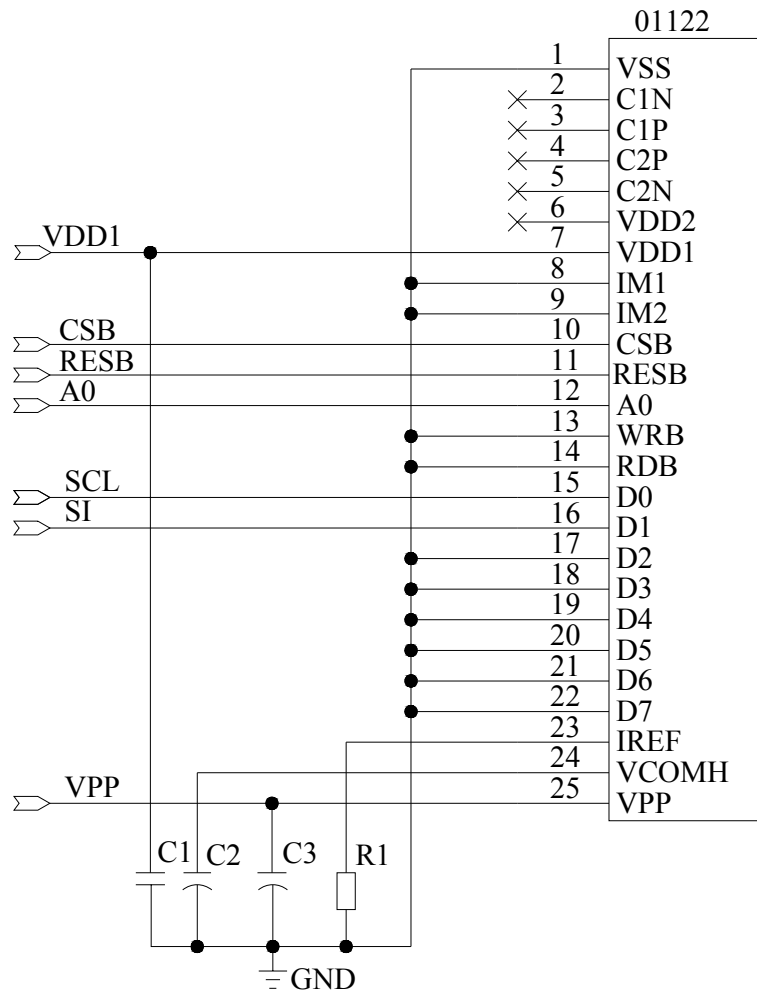

Pin connected to MCU interface: SCL,SI, CSB,A0,RESB

Recommended components

C1 : 1uF-0603-X7R±10%.RoHS

C2,C3 : 4.7µF/25V.RoHS (Tantalum Capacitors)

R1: 0603 1/10W +/-5% 390K ohm.RoHS

(4).The configuration for I²C interface mode, external VPP is shown in the following diagram:

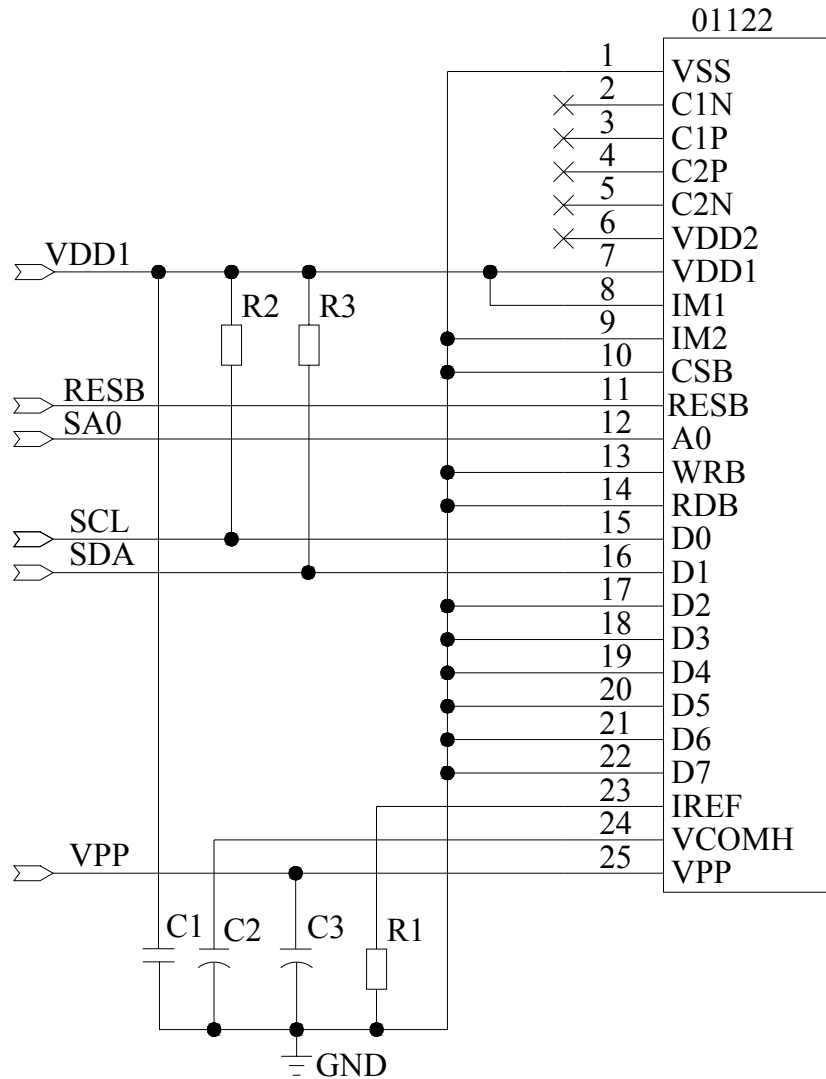

Pin connected to MCU interface: SCL,SDA, SA0,RESB

SA0	I ² C Address
0	0x78
1	0x7a

Recommended components

C1: 1uF-0603-X7R±10%.RoHS

C2,C3 : 4.7µF/25V.RoHS (Tantalum Capacitors)

R1: 0603 1/10W +/-5% 390K ohm.RoHS

R2, R3: 0603 1/10W +/-5% 10K ohm.RoHS

9.2.2 Under Internal DC/DC Mode, the charge Pump Setting (ADh) must be set as follow:

ADh: Charge Pump Setting 8Bh: Enable Charge Pump

The configuration for 8080-parallel interface mode, VPP Generated by Internal DC/DC Circuit is shown in the following diagram:

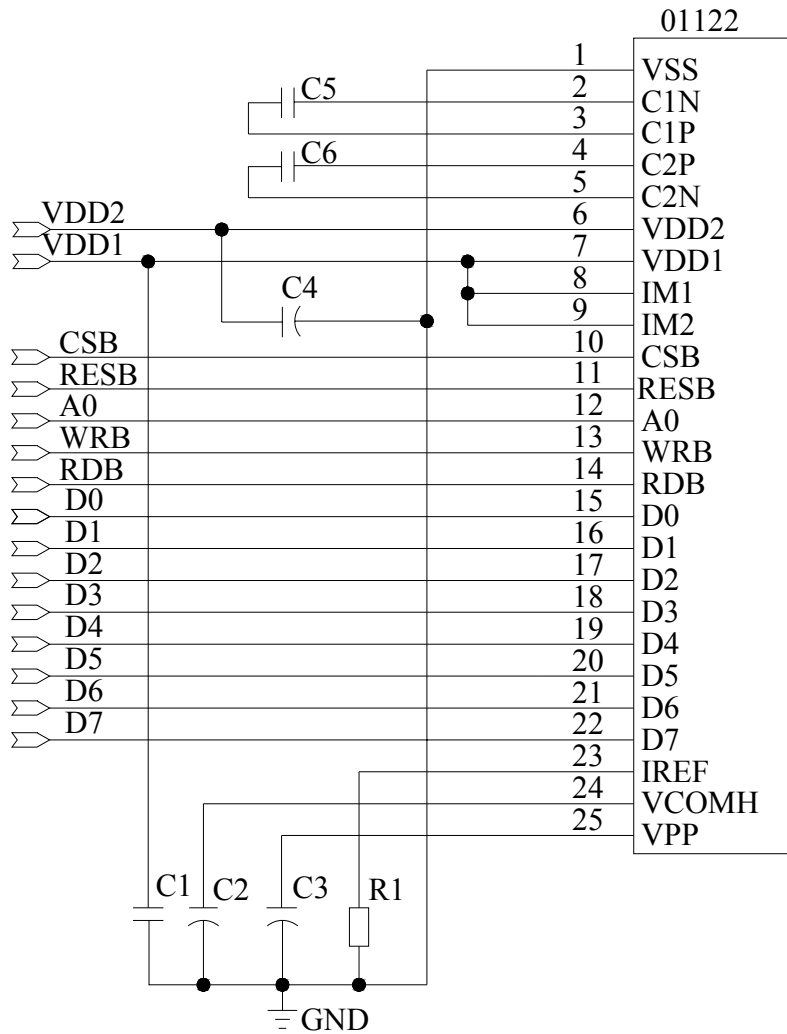

Pin connected to MCU interface: D[0:7], RDB, WRB, A0, RESB, CSB

Recommended components

C1, C5, C6: 1uF-0603-X7R±10%.RoHS

C2,C3,C4 : 4.7µF/25V.RoHS (Tantalum Capacitors)

R1: 0603 1/10W +/-5% 390K ohm.RoHS

9.3 External DC-DC application circuit

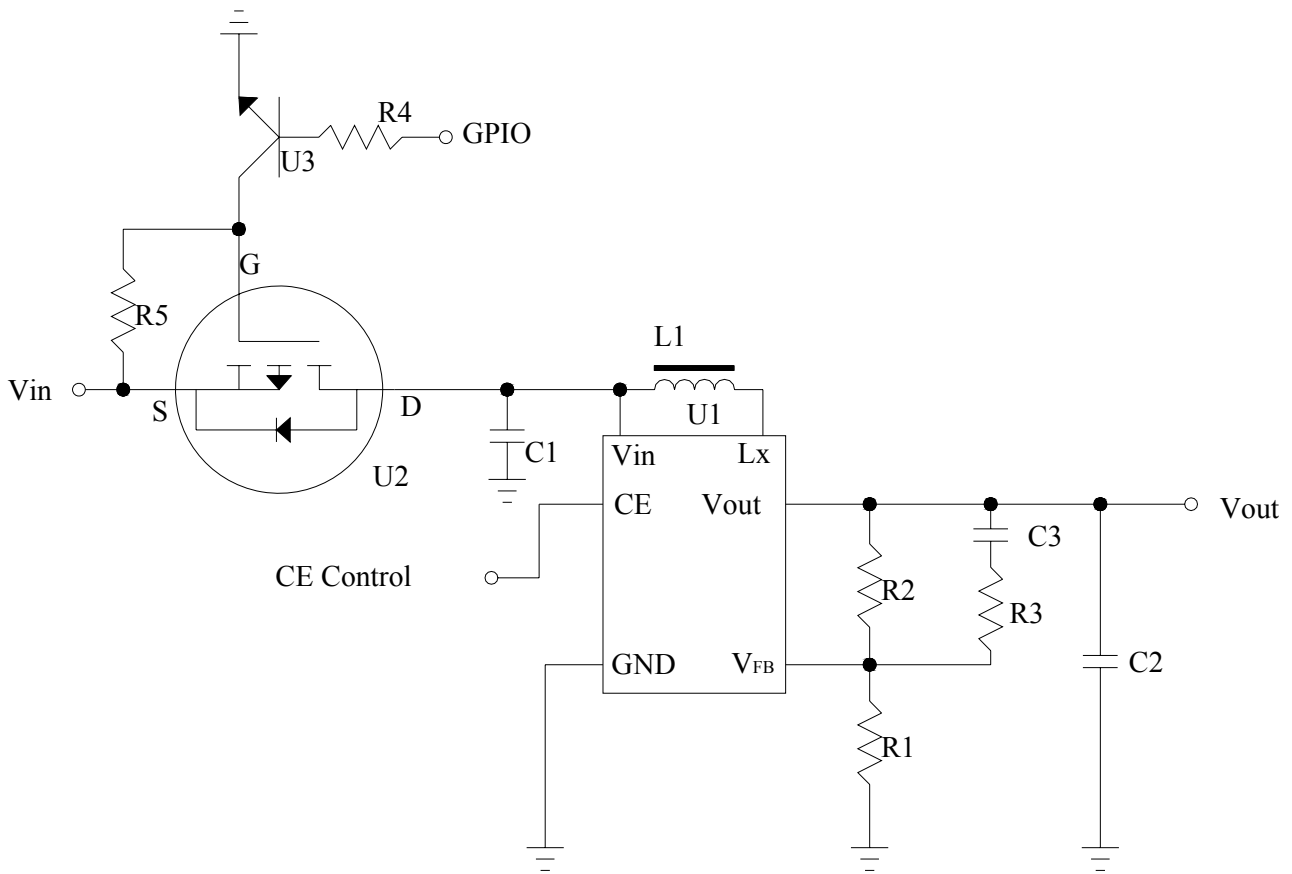

Recommend component

- The C1 : 1 uF-0603-X7R±10%.RoHS
- The C2 : 1 uF-0603-X7R±10%.RoHS
- The C3 : 220pF-0603-X7R±10%.RoHS
- The R1 : 0603 1/10W +/-5% 10Kohm.RoHS
- The R2 : 0603 1/10W +/-5% 70Kohm.RoHS
- The R3 : 0603 1/10W +/-5% 2Kohm.RoHS
- The R4 : 0603 1/10W +/-5% 1Kohm.RoHS
- The R5 : 0603 1/10W +/-5% 10Kohm.RoHS
- The L1 : 22uH
- The U1 : R1200
- The U2 : FDN338P
- The U3 : 8050

9.4 Display Control Instruction

Refer to SH1106G IC Specification.



9.5 Recommended Software Initialization

In order to ensure the reliability and stability of the module, the module must initialize use the following code, Malfunctioning of the module may occur and the reliability of the module may deteriorate if the module is used beyond the initialize code.

```

void Init_IC()
{
    Write_Command(0xAE);        //Display Off
    Write_Command(0xD5);        //Divide Ratio/Oscillator Frequency Mode Set
    Write_Command(0x51);
    Write_Command(0xA8);        //Multiplex Ration Mode Set
    Write_Command(0x1F);
    Write_Command(0xD3);        //Display Offset Mode Set
    Write_Command(0x10);
    Write_Command(0x40);        //Set Display Start Line
    Write_Command(0xAD);        //DC-DC Control Mode Set
    Write_Command(0x8B);
    Write_Command(0x31);
    Write_Command(0xA1);        //Set Segment Re-map
    Write_Command(0xC8);        //Set Common Output Scan Direction:
    Write_Command(0xDA);        //Common Pads Hardware Configuration Mode Set
    Write_Command(0x12);
    Write_Command(0x81);        //The Contrast Control Mode Set
    Write_Command(0x58);
    Write_Command(0xD9);        //Pre-charge Period Mode Set:
    Write_Command(0x22);
    Write_Command(0xDB);        //VCOM Deselect Level Mode Set
    Write_Command(0x25);
    Write_Command(0xA4);        //Set Entire Display OFF/ON
    Write_Command(0xA6);        //Set Normal/Reverse Display
    Clear_Screen();
    Write_Command(0xAF);        //Display On
}
    
```

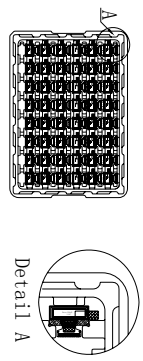
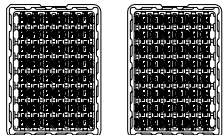
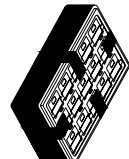
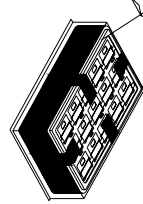
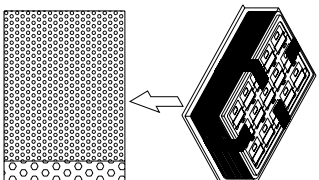
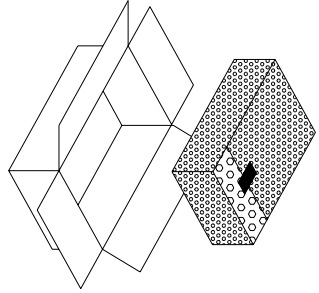
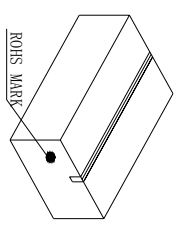
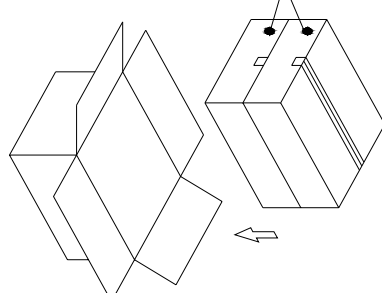
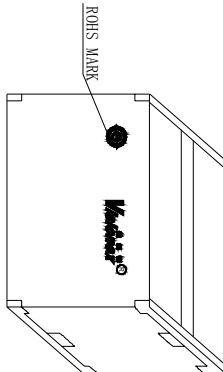
10 Package Specification

Controlled Seal		Packing Process (1)~(9)		
<p>(1) Tray Type:00802-MT6-A</p> 	<p>(2)</p>  <p>TRAY</p>	<p>(3) order ① ② ① ② fix trays with tape 1078 pcs of 1 small carton 1 tray contain 49 pcs 22 contained trays, 1 empty tray</p> 	<p>(4) Use vacuum bag to package the tray and add 5 bags of desiccant into the vacuum bag *5</p> 	
<p>(5) After tray be packaged, wrap the package in a bubble bag and seal with scoth tape.</p> 	<p>(6)</p> 	<p>(7)</p> <p>small carton package L390*W290*L120 mm</p> 	<p>(8)</p>  <p>2 small cartons in 1 big carton</p>	
<p>(9) 24 contained trays, 2 empty trays, Package quantity products: 2156 pcs of 1 big carton</p>  <p>Package finished L410*W310*L272 mm</p>	<p>NOTE:1、 The inner carton and master carton must be sealed with adhesive tape. 2、 Fill up the gap with tray. 3、 If the customer has special needs with the RoHS making, the inner carton and master carton need adhesive new RoHS marking at  .</p>			

11 Reliability

11.1 Reliability Test

NO.	ITEM	CONDITION	QUANTITY
1	High Temperature (Non-operation)	85°C,240hrs	4
2	Low Temperature (Non-operation)	-40°C,240hrs	4
3	High Temperature (Operation)	70°C,240hrs	4
4	Low Temperature (Operation)	-40°C,240hrs	4
5	High Temperature / High Humidity (Operation)	60°C,90%RH,240hrs	4
6	Thermal shock (Non-operation)	-40°C~85°C(-40°C/30min;transit/3min;85°C/30min;transit/3min) 1cycle: 66min,30cycles	4
7	Vibration	Frequency: 5~50Hz,0.5G Scan rate: 1 oct/min Time: 2 hrs/axis Test axis: X,Y, Z	1 Carton
8	Drop	Height: 100 cm Sequence: 1 angle, 3 edges and 6 faces	1 Carton

Test and measurement conditions

- All measurements shall not be started until the specimens attain to temperature stability, the stable time is at least 15 minutes.
- The degradation of polarizer is ignored for item 5.
- The tolerance of temperature is $\pm 3^{\circ}\text{C}$, and the tolerance of relative humidity is $\pm 5\%$.

Evaluation criteria

- The function test is OK.
- No observable defects.
- Luminance: $\geq 50\%$ of initial value.
- Current consumption: within $\pm 50\%$ of initial value.

11.2 Lifetime

End of lifetime is specified as 50% of initial brightness and the test pattern at operating condition is 50% alternating checkerboard.

ITEM	MIN	MAX	UNIT	CONDITION
Operation Life Time	10,000	-	hrs	150 cd/m ² , 50% alternating checkerboard 22 \pm 3°C, 55 \pm 15% RH.

11.3 Failure Check Standard

After the completion of the described reliability test, the samples were left at room temperature for 2 hrs prior to conducting the failure test at 22 \pm 3°C; 55 \pm 15% RH.

11 Illustration of OLED Product Name

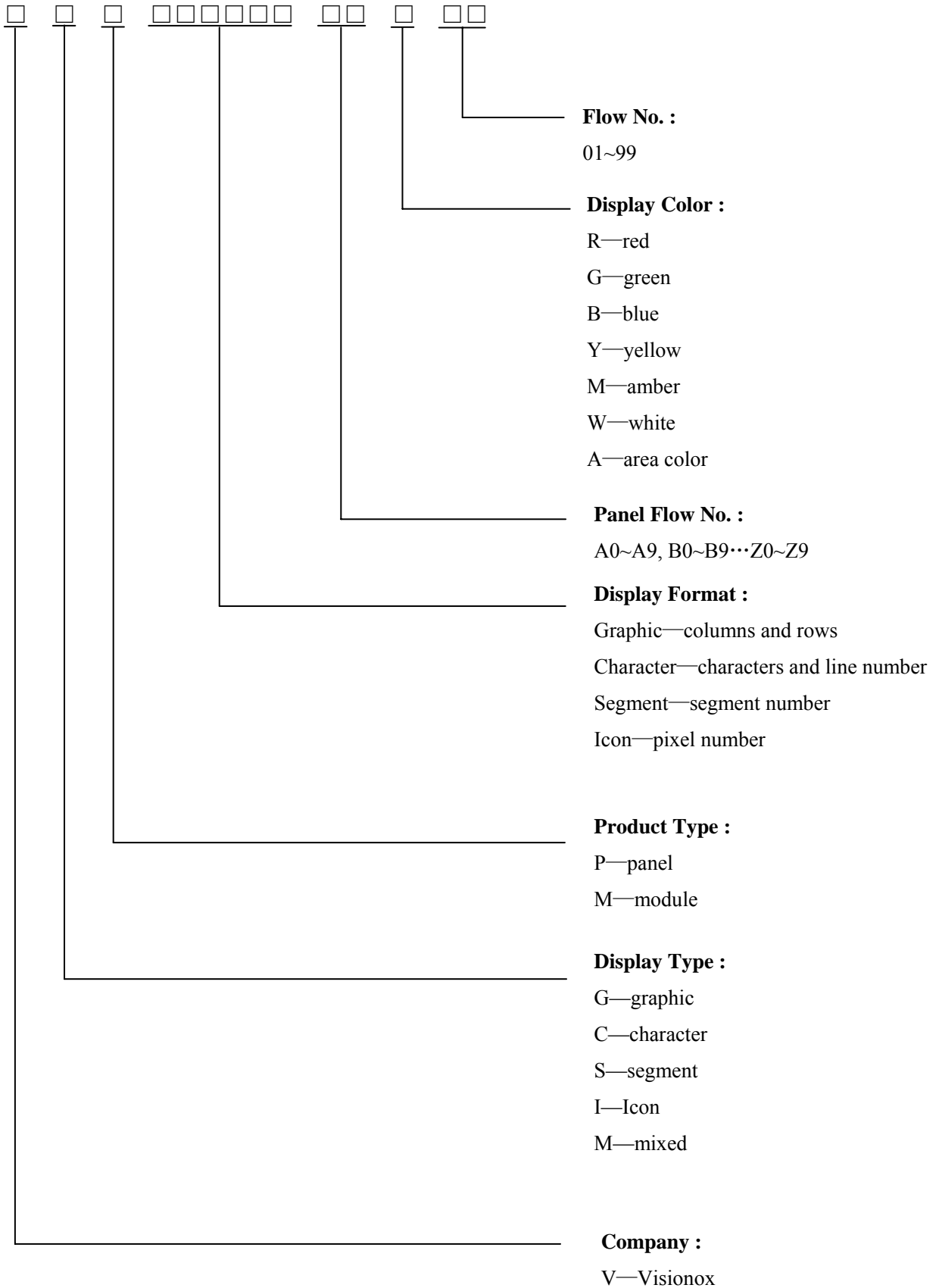

12 Outgoing Quality Control Specifications

12.1 Sampling Method

- (1) GB/T 2828.1-2003/ISO2859-1: 1999, inspection level II , normal inspection, single sample inspection
- (2) AQL: Major 0.65; Minor 1.0

12.2 Inspection Conditions

The environmental conditions for test and measurement are performed as follows.

Temperature: $22 \pm 3^{\circ}\text{C}$

Humidity: $55 \pm 15\% \text{R.H}$

Fluorescent Lamp: 30W

Distance between the Panel & Lamp: $\geq 50\text{cm}$

Distance between the Panel & Eyes: $\geq 30\text{cm}$

Viewing angle from the vertical in each direction: $\leq 45^{\circ}$

(See the sketch below)

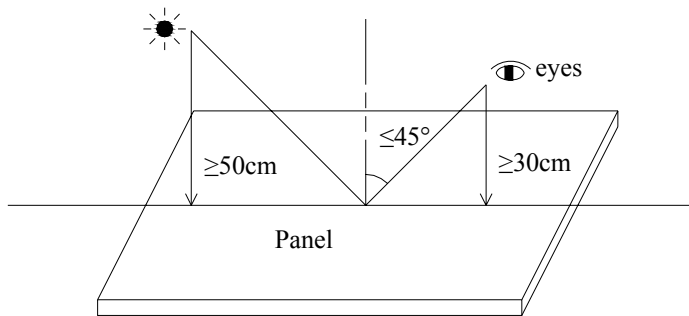

12.3 Quality Assurance Zones

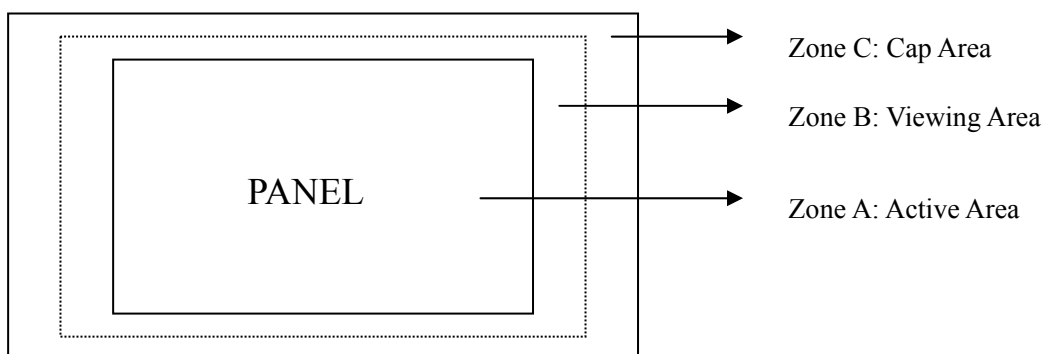

12.4 Inspection Standard

Definition of Φ &L&W (Unit: mm)

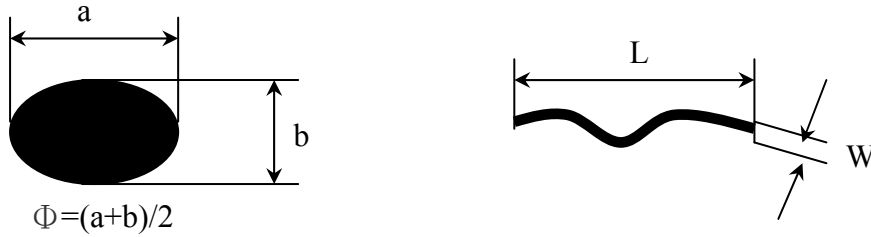

I . Appearance Defects

NO.	ITEM	CRITERIA	CLASSIFICATION																		
1	Polarizer Black or White spot, Dirty spot, Foreign matter, Dent on the polarizer	<table border="1"> <thead> <tr> <th rowspan="2">Average Diameter (mm)</th> <th colspan="2">Acceptable Number</th> </tr> <tr> <th>Zone A,B</th> <th>Zone C</th> </tr> </thead> <tbody> <tr> <td>$\Phi \leq 0.15$</td> <td colspan="2">Ignore</td> </tr> <tr> <td>$0.15 < \Phi \leq 0.30$</td> <td colspan="2">3</td> </tr> <tr> <td>$\Phi > 0.30$</td> <td colspan="2">0</td> </tr> </tbody> </table>	Average Diameter (mm)	Acceptable Number		Zone A,B	Zone C	$\Phi \leq 0.15$	Ignore		$0.15 < \Phi \leq 0.30$	3		$\Phi > 0.30$	0		Minor				
Average Diameter (mm)	Acceptable Number																				
	Zone A,B	Zone C																			
$\Phi \leq 0.15$	Ignore																				
$0.15 < \Phi \leq 0.30$	3																				
$\Phi > 0.30$	0																				
2	Scratch/line on the glass/Polarizer	<table border="1"> <thead> <tr> <th rowspan="2">Width (mm)</th> <th rowspan="2">Length (mm)</th> <th colspan="2">Acceptable Number</th> </tr> <tr> <th>Zone A,B</th> <th>Zone C</th> </tr> </thead> <tbody> <tr> <td>$W \leq 0.03$</td> <td>---</td> <td colspan="2">Ignore</td> </tr> <tr> <td>$0.03 < W \leq 0.08$</td> <td>$L \leq 5.0$</td> <td colspan="2">3</td> </tr> <tr> <td>$W > 0.08$</td> <td>---</td> <td colspan="2">0</td> </tr> </tbody> </table>	Width (mm)	Length (mm)	Acceptable Number		Zone A,B	Zone C	$W \leq 0.03$	---	Ignore		$0.03 < W \leq 0.08$	$L \leq 5.0$	3		$W > 0.08$	---	0		Minor
Width (mm)	Length (mm)	Acceptable Number																			
		Zone A,B	Zone C																		
$W \leq 0.03$	---	Ignore																			
$0.03 < W \leq 0.08$	$L \leq 5.0$	3																			
$W > 0.08$	---	0																			
3	Polarizer Bubble	<table border="1"> <thead> <tr> <th rowspan="2">Average Diameter (mm)</th> <th colspan="2">Acceptable Number</th> </tr> <tr> <th>Zone A,B</th> <th>Zone C</th> </tr> </thead> <tbody> <tr> <td>$\Phi > 0.5$</td> <td colspan="2">0</td> </tr> <tr> <td>$0.2 < \Phi \leq 0.5$</td> <td colspan="2">3</td> </tr> <tr> <td>$\Phi \leq 0.2$</td> <td colspan="2">Ignore</td> </tr> </tbody> </table>	Average Diameter (mm)	Acceptable Number		Zone A,B	Zone C	$\Phi > 0.5$	0		$0.2 < \Phi \leq 0.5$	3		$\Phi \leq 0.2$	Ignore		Minor				
Average Diameter (mm)	Acceptable Number																				
	Zone A,B	Zone C																			
$\Phi > 0.5$	0																				
$0.2 < \Phi \leq 0.5$	3																				
$\Phi \leq 0.2$	Ignore																				
4	Any Dirt & Scratch on Polarizer's Protective Film	Ignore for not affect the polarizer.	Minor																		
5	Any Dirt on Cap Glass	<table border="1"> <thead> <tr> <th>Average Diameter (mm)</th> <th>Acceptable Number</th> </tr> </thead> <tbody> <tr> <td>$\Phi \leq 0.5$</td> <td>Ignore</td> </tr> <tr> <td>$0.5 < \Phi \leq 1.0$</td> <td>3</td> </tr> <tr> <td>$\Phi > 1.0$</td> <td>0</td> </tr> </tbody> </table>	Average Diameter (mm)	Acceptable Number	$\Phi \leq 0.5$	Ignore	$0.5 < \Phi \leq 1.0$	3	$\Phi > 1.0$	0	Minor										
Average Diameter (mm)	Acceptable Number																				
$\Phi \leq 0.5$	Ignore																				
$0.5 < \Phi \leq 1.0$	3																				
$\Phi > 1.0$	0																				

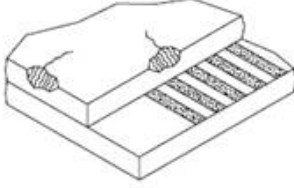
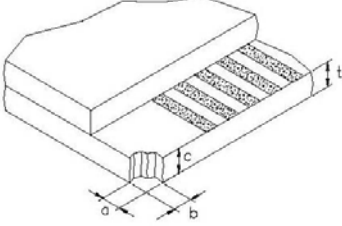
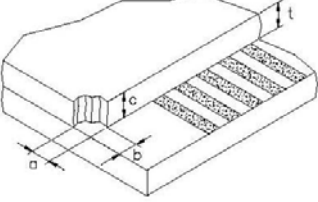
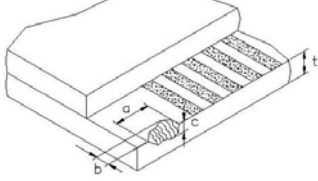
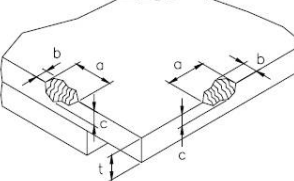
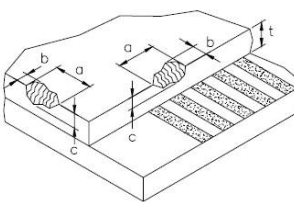
6	Glass Crack	 <p>Propagation crack is not acceptable.</p>	Major
7	Corner Chip	 <p>t= Glass thickness Accept $a \leq 2.0\text{mm}$ or $b \leq 2.0\text{mm}$, $c \leq t$</p>	Minor
8	Corner Chip on Cap Glass	 <p>t= Glass thickness Accept $a \leq 1.5\text{mm}$ or $b \leq 1.5\text{mm}$, $c \leq t$</p>	Minor
9	Chip on Contact Pad	 <p>t= Glass thickness Accept $a \leq 3.0\text{mm}$ or $b \leq 0.8\text{mm}$, $c \leq t$ (on the contact pin) $a \leq 3.0\text{mm}$ or $b \leq 1.5\text{mm}$, $c \leq t$ (outside of the contact pin)</p>	Minor
10	Chip on Face of Display	 <p>t= Glass thickness Accept $a \leq 1.5\text{mm}$ or $b \leq 1.5\text{mm}$, $c \leq t$</p>	Minor
11	Chip on Cap Glass	 <p>t= Glass thickness Accept $a \leq 3.0\text{mm}$ or $b \leq 3.0\text{mm}$, $c \leq t/2$ $a \leq 1.5\text{mm}$ or $b \leq 1.5\text{mm}$, $t/2 \leq c \leq t$</p>	Minor
12	Stain on Surface	Stain removable by soft cloth or air blow is acceptable.	Minor
13	TCP/FPC Damage	<p>(1) Crack, deep scratch, deep hole and deep pressure mark on the TCP/FPC are not acceptable.</p> <p>(2) Terminal lead twisted or broken is not allowable.</p> <p>(3) Copper exposed is not allowed by naked eye inspection.</p>	Minor
14	Dimension Unconformity	Checking by mechanical drawing.	Major

II. Displaying Defects

NO.	ITEM	CRITERIA	CLASSIFICATION														
1	Black/White spot Dirty spot Foreign matter	<table border="1"> <thead> <tr> <th data-bbox="517 416 794 488">Average Diameter (mm)</th> <th colspan="2" data-bbox="794 416 1155 450">Pieces Permitted</th> </tr> <tr> <td data-bbox="517 450 794 488"></td> <th data-bbox="794 450 979 488">Zone A,B</th> <th data-bbox="979 450 1155 488">Zone C</th> </tr> </thead> <tbody> <tr> <td data-bbox="517 488 794 521">$\Phi \leq 0.10$</td> <td colspan="2" data-bbox="794 488 1155 521">Ignore</td> </tr> <tr> <td data-bbox="517 521 794 555">$0.10 < \Phi \leq 0.20$</td> <td data-bbox="794 521 979 555">3</td> <td data-bbox="979 521 1155 555" rowspan="2">Ignore</td> </tr> <tr> <td data-bbox="517 555 794 589">$\Phi > 0.20$</td> <td data-bbox="794 555 979 589">0</td> </tr> </tbody> </table>	Average Diameter (mm)	Pieces Permitted			Zone A,B	Zone C	$\Phi \leq 0.10$	Ignore		$0.10 < \Phi \leq 0.20$	3	Ignore	$\Phi > 0.20$	0	Minor
Average Diameter (mm)	Pieces Permitted																
	Zone A,B	Zone C															
$\Phi \leq 0.10$	Ignore																
$0.10 < \Phi \leq 0.20$	3	Ignore															
$\Phi > 0.20$	0																
2	No Display	Not allowable.	Major														
3	Irregular Display	Not allowable.	Major														
4	Missing Line (row or column)	Not allowable.	Major														
5	Short	Not allowable.	Major														
6	Flicker	Not allowable.	Major														
7	Abnormal Color	Refer to the SPEC.	Major														
8	Luminance NG	Refer to the SPEC.	Major														
9	Over Current	Refer to the SPEC.	Major														

13 Precautions for operation and Storage

13.1 Precautions for Operation

- (1) Since OLED panel is made of glass, do not apply any mechanical shock or impact or excessive force to it when installing the OLED module. Any strong mechanical impact due to falling dropping etc. may cause damage (breakage or cracking).
- (2) The polarizer on the OLED surface is made of soft material and is easily scratched. Please take most care when handing. When the surface of the polarizer of OLED Module is contaminated, please wipe it off gently by using moisten soft cloth with isopropyl alcohol, do not use water, ketone or aromatics. If there is saliva or water on the OLED surface, please wipe it off immediately.
- (3) When handling OLED module, please be sure that the body and the tools are properly grounded. And do not touch I/O pins with bare hands or contaminate I/O pins, it will cause disconnection or defective insulation of terminals.
- (4) Do not attempt to disassemble or process the OLED module.
- (5) OLED module should be used under recommended operating conditions shown in the specification. Since the higher voltage leads to the shorter lifetime, be sure to use the specified operating voltage.
- (6) Foggy dew, moisture condensation or water droplets deposited on surface and contact terminals will cause polarizer stain or damage, the deteriorated display quality and electrochemical reaction then leads to shorter life time and permanent damage to the module probably. Please pay attention to the environmental temperature and humidity.
- (7) An afterimage is created by the difference in brightness between unused dot and the fixed dot, according to the decrease of brightness of the emitting time. Therefore, to avoid having an afterimage, the full set should be thoroughly used instead of using a fixed dot. When the fixed dot emits, an afterimage can be created.
- (8) Flicker could be come out at full on display. And it disappears when frame frequency increase, but brightness decreases too.

13.2 Soldering

- (1) Soldering should be performed only on the I/O terminals.
- (2) Use soldering irons with proper grounding and no leakage.
- (3) Iron: The temperature setting of electric iron is 350°C, but we suggest that during soldering, the temperature of iron tip should be no higher than 330°C and soldering be finished within 3~4 seconds.

13.3 Precautions for Storage

- (1) Please store OLED module in a dark place. Avoid exposure to sunlight, the light of fluorescent lamp or any ultraviolet ray.
- (2) Keep the environment temperature between 10°C and 35°C and the relative humidity less than 60%. Avoid high temperature and high humidity.
- (3) Keep the OLED modules stored in the container when shipped from supplier before using them is recommended.
- (4) Do not leave any article on the OLED module surface for an extended period of time.

13.4 Warranty period

Visionox warrants for a period of 12 months from the shipping date when stored or used under normal condition.



Компания «ЭлектроПласт» предлагает заключение долгосрочных отношений при поставках импортных электронных компонентов на взаимовыгодных условиях!

Наши преимущества:

- Оперативные поставки широкого спектра электронных компонентов отечественного и импортного производства напрямую от производителей и с крупнейших мировых складов;
- Поставка более 17-ти миллионов наименований электронных компонентов;
- Поставка сложных, дефицитных, либо снятых с производства позиций;
- Оперативные сроки поставки под заказ (от 5 рабочих дней);
- Экспресс доставка в любую точку России;
- Техническая поддержка проекта, помощь в подборе аналогов, поставка прототипов;
- Система менеджмента качества сертифицирована по Международному стандарту ISO 9001;
- Лицензия ФСБ на осуществление работ с использованием сведений, составляющих государственную тайну;
- Поставка специализированных компонентов (Xilinx, Altera, Analog Devices, Intersil, Interpoint, Microsemi, Aeroflex, Peregrine, Syfer, Eurofarad, Texas Instrument, Miteq, Cobham, E2V, MA-COM, Hittite, Mini-Circuits, General Dynamics и др.);

Помимо этого, одним из направлений компании «ЭлектроПласт» является направление «Источники питания». Мы предлагаем Вам помощь Конструкторского отдела:

- Подбор оптимального решения, техническое обоснование при выборе компонента;
- Подбор аналогов;
- Консультации по применению компонента;
- Поставка образцов и прототипов;
- Техническая поддержка проекта;
- Защита от снятия компонента с производства.



Как с нами связаться

Телефон: 8 (812) 309 58 32 (многоканальный)

Факс: 8 (812) 320-02-42

Электронная почта: org@eplast1.ru

Адрес: 198099, г. Санкт-Петербург, ул. Калинина, дом 2, корпус 4, литера А.