

# Amphenol

# Circular Interconnects

Products for Military, Aerospace and Harsh Environments

- Aluminum
- Stainless Steel/Firewall
- Composite
- Printed Circuit Board Connectors
- High Speed Connectors
- EMI Filter/Transient
- \* Fiber Optics
- Full Complement of Contacts
- Accessories



The Interconnection Leader



## CONTACT US:

Amphenol Aerospace  
40-60 Delaware Avenue  
Sidney, NY 13838-1395

Customer Service: Mon.-Friday 8 am - 5 pm  
Phone: (800)678-0141  
Fax: (607)563-5157  
Online: [www.amphenol-aerospace.com](http://www.amphenol-aerospace.com)



## ABOUT AMPHENOL AEROSPACE:

Amphenol Aerospace, a Division of Amphenol Corporation, is one of the largest manufacturers of interconnect products in the world for the Military, Commercial Aerospace and Industrial markets. Amphenol designs, manufactures and markets circular and rectangular, electronic, fiber optic, EMI/EMP filter, and a variety of special applications connectors and interconnect systems.

Our 675,000 square foot facility is nestled at the foothills of the Catskill Mountains in Sidney NY. The Amphenol complex houses state-of-the-art manufacturing technologies including CNC machining, die-casting, molding, impact and extruding, plating, screw machining and process controls. Our fully equipped material evaluation lab and engineering organization, utilizing the latest in computer aided design software and analysis tools, allows us to design, test, and qualify interconnect systems.

Amphenol's interconnect products are supplied to thousands of OEMs worldwide and are supported by our worldwide sales and engineering force, including the largest global network of electronic distributors.

The Amphenol Aerospace Division consists of the interconnect facility in NY; two facilities in NH that manufacture electrical backplanes, rigid boards and flex assemblies; an interconnect facility in Toronto, Canada; and satellite assembly plants in Mexico and China.

## AMPHENOL AEROSPACE'S PHILOSOPHY:

As a basic business philosophy, Amphenol Aerospace is dedicated to concentrating on those advanced and challenging market segments that demand an extraordinary level of supplier support and reaction. Our approach to implement this strategy is based on the following key principles:

**FOCUS:** Concentrate all resources on serving a limited number of tightly defined markets, and understanding the needs of those markets.

**INNOVATION:** Provide these markets new, creative solutions in both products and services.

**RESPONSIVENESS:** Identify and respond to the market and product needs more rapidly than any other supplier.

Performance is the sum of these principles. It is the measure of how well we continually and consistently implement our basic strategy and key principles.



## CUSTOMIZED INTERCONNECT PACKAGES:

Amphenol Corporation's broad technical, product and manufacturing resources enable Amphenol Aerospace to provide exceptional performance in the area of customized system development-application specific packaging which blends both Corporate and Amphenol Aerospace products and design innovations. We provide customers with rapid, well engineered and cost-effective custom interconnect solutions.

## QUALITY ASSURANCE:

Amphenol Aerospace has been awarded both AS9100 - Revision B and ISO9001:2000 quality assurance certifications.

III  
II  
I  
SJT  
38999

26482  
Matrix 2

83723 III  
Matrix  
Pyle

5015  
Crimp Reel  
Release Matrix

26500 Pyle

Printed  
Circuit Board

EMI Filter  
Transient

Fiber Optics

High Speed  
Contacts

Options  
Others

|              |                           |
|--------------|---------------------------|
| 38999        | III                       |
| SJT          | II                        |
| 26482        | Matrix 2                  |
| 83723        | III Pyle                  |
| 5015         | Matrix                    |
| 5015         | Crimp Rear Release Matrix |
| 26500        | Pyle                      |
| Printed      | Circuit Board             |
| EMI Filter   | Transient                 |
| Fiber Optics |                           |
| High Speed   | Contacts                  |
| Options      | Others                    |

## MIL-DTL-38999 Series III, TV Tri-Start



Pages  
 4-7 Shell & Insert Chart  
 8-14 Insert Arrangements  
 17-44 TV Section  
 89-108 Accessories, Contacts, and Tools

## MIL-DTL-38999 Series II, JT



Pages  
 4-7 Shell & Insert Chart  
 8-14 Insert Patterns  
 45-66 JT Section  
 89-108 Accessories, Contacts, and Tools

## MIL-DTL-38999 Series I, LJT



Pages  
 4-7 Shell & Insert Chart  
 8-14 Insert Patterns  
 67-80 LJT Section  
 89-108 Accessories, Contacts, and Tools

## SJT



Pages  
 84 Shell & Insert Chart  
 8-12 Insert Arrangements  
 81-88 SJT Section  
 89-108 Accessories, Contacts, and Tools

## MIL-DTL-26482 Matrix 2



Pages  
 111 Shell & Insert Chart  
 112, 113 Insert Arrangements  
 116-118 Shell Styles  
 119 Accessories, Contacts, and Tools

## MIL-DTL-83723 Matrix



Pages  
 124 Shell & Insert Chart  
 125, 126 Insert Arrangements  
 128-135 Shell Styles  
 136 Accessories, Contacts, and Tools

## MIL-DTL-83723 Pyle



Pages  
 146 Shell & Insert Chart  
 147, 148 Insert Arrangements  
 157-165 Shell Styles  
 166-169 Accessories, Contacts, and Tools

## MIL-DTL-5015 Crimp Rear Release Matrix



Pages  
 172-173 Shell & Insert Chart  
 174-182 Insert Patterns  
 186-192 Shell Styles  
 194-197 Accessories, Contacts, and Tools

## MIL-DTL-26500 Pyle



Pages  
 203, 204 Insert Patterns  
 209-223 Shell Styles  
 226-235 Accessories, Contacts, and Tools

## Printed Circuit Board



Pages  
 239 Shell & Insert Chart  
 241-255 Insert Arrangements  
 256-275 Shell Styles  
 276 Stand-off Adapter

## EMI Filter Transient



Pages  
 282-285 Filter Data  
 288, 289 How to Order  
 290-331 Shell Styles  
 332-338 Adapters, MOV, Diode, ESA and Specials

## Fiber Optics



Pages  
 347 Shell & Insert Chart  
 348, 349 Insert Patterns  
 350-360 Shell Styles  
 361-364 Accessories, Tools and Cable Systems

## High Speed Contacts



Pages  
 372-375 Cable Usage Guide  
 376 Overview  
 377-406 MIL-DTL-38999 Contacts  
 407-414 MIL-DTL-5015 & MIL-DTL-22992

## Options Others



Pages  
 415-431 Additional Circulars  
 432-435 Additional Rectangular



Amphenol has become the leader in interconnection products through its long history of engineering expertise for product solution solving. New and innovative solutions are under development every day within our highly skilled engineering departments who are teamed with marketing product managers and production specialists. They are always striving to meet new customer requirements in ever changing markets. The teams have a customer-driven approach to produce the end result: quality interconnect products that meet or exceed customer demands.



**New/Featured**  
**Breakaway Hybrid, Low Profile Lanyard Release Plug**  
 Page 42

New Hybrid Lanyard Breakaway Fail Safe Connector with a composite thermoplastic outer operating sleeve for greater durability.

Solution: Navy F-18 program needed a break away plug that would have greater durability in weapons release application.



**New/Featured**  
**New HD38999 (High Density, Crimp) Plugs and receptacles**  
 Page 43, 44

The HD38999 family of connectors was designed to work with existing Mil-specified 38999 shells. The HD38999 has 30% more contacts, it still performs to minimum electrical requirements of standard 38999 connectors.

Solution: 30% more contact density in 38999 Series III Shells



**New/Featured**  
**Matrix MIL-DTL-5015 with RADSOK® Contacts**  
 Page 193

A special design of the Matrix MIL-DTL-5015, Series II connectors has added high amperage with the RADSOK® contacts in the plug instead of standard rear release crimp contacts.

Solution: Higher amperage capability in Matrix MIL-DTL-5015



**New/Featured**  
**Filter Connector with High Density Patterns**  
 Page 289

New High Density Patterns are available in Filter 38999 connectors in standard Mil-Spec or filter length shells. They provide 30% more contact than standard insert arrangement patterns. See page 43 for ordering information.

Solution: Higher contact density and custom stand-off shell designs



**New/Featured**  
**ARINC 801 Connectors**  
 Page 356

Designed for use in Amphenol ARINC 801 fiber optic connectors - manufactured to comply with ARINC 801. Genderless terminus allows for use on both sides of a connector.

Solution: Fiber Optic Termini & Connector that meet ARINC specifications



**New/Featured**  
**MT Ferrule Connectors**  
 Page 359

Amphenol offers a multi-channel circular connector with high density MT fiber optics. High fiber density in a relatively small circular connector package with all the advantages of the MIL-DTL-38999 series III connector.

Solution: Higher Density Fiber Optics in MIL-DTL-38999

38999  
III  
II  
I  
SJT

26482  
Matrix 2

83723 III  
Matrix Pyle

5015  
Crimp Rear Release Matrix

26500 Pyle

Printed  
Circuit Board

EMI Filter  
Transient

Fiber Optics

High Speed  
Contacts

Options  
Others



38999  
SJT

26482  
Matrix 2

83723 III  
Matrix Pyle

5015  
Crimp Rear Release Matrix

26500 Pyle

Printed  
Circuit Board

EMI Filter  
Transient

Fiber Optics

High Speed  
Contacts

Options  
Others

| Series | Series | Series  | Military | JT/LJT |       | Hermetics |         |     | Service Rating | Total Contacts | Contact Size |     |    |     |    |    |           |            |          |              |   |
|--------|--------|---------|----------|--------|-------|-----------|---------|-----|----------------|----------------|--------------|-----|----|-----|----|----|-----------|------------|----------|--------------|---|
|        |        |         |          | Solder | Crimp | Class H   | Class Y | TV* |                |                | 22D          | 22M | 22 | 20  | 16 | 12 | 12 (Coax) | 10 (Power) | 8 (Coax) | 8†† (Twinax) |   |
| 8-2■   |        |         |          | P      |       |           |         |     | M              | 2              |              |     |    | 2   |    |    |           |            |          |              |   |
| 8-3■   |        |         |          | X      | NA    | P         | P       |     | M              | 3              |              |     |    | 3   |    |    |           |            |          |              |   |
|        | 9-3■   |         |          | X      |       |           |         |     |                |                |              |     |    |     |    |    |           |            |          |              |   |
|        |        | 9-5★■   |          |        |       |           |         |     | Grounded       | 1              |              |     |    |     |    |    |           |            |          |              | 1 |
| 8-6    |        |         |          | X      | X     | P         | P       |     | M              | 6              |              | 6   |    |     |    |    |           |            |          |              |   |
|        | 9-6    |         |          | X      | X     | P         | P       |     | M              | 7              |              | 7   |    |     |    |    |           |            |          |              |   |
|        | 9-7■   |         |          | X      |       |           |         |     | M              | 7              |              |     |    |     |    |    |           |            |          |              |   |
|        | 9-22■  |         |          | X      |       |           |         |     | I              | 2              |              |     |    | 2   |    |    |           |            |          |              |   |
| 8-35   |        |         |          |        | X     | P         | P       |     | M              | 6              | 6            |     |    |     |    |    |           |            |          |              |   |
|        | 9-35   | 9-35    | A35      |        | X     | P         | P       | P   | M              | 6              |              |     |    |     |    |    |           |            |          |              |   |
| 8-44   |        |         |          |        | X     | P         | P       |     | M              | 4              |              |     | 4  |     |    |    |           |            |          |              |   |
|        | 9-44   |         |          |        | X     |           |         |     | M              | 4              |              |     |    |     |    |    |           |            |          |              |   |
|        |        | 9-94 ■  |          |        | ◆     |           |         |     | M              | 2              |              |     |    |     |    |    |           |            |          |              |   |
| 8-97■  |        |         |          | X      |       |           |         |     | M              | 4              |              | 2   |    | 2   |    |    |           |            |          |              |   |
| 8-98   |        |         |          | S      | X     | P         | P       |     | I              | 3              |              |     |    | 3   |    |    |           |            |          |              |   |
|        | 9-98   | 9-98    | A98      | X      | X     | P         | P       | P   | I              | 3              |              |     |    |     |    |    |           |            |          |              |   |
|        | 11-2★  | 11-2★   | B2       |        | X     | P**       |         |     | I              | 2              |              |     |    | 2   |    |    |           |            |          |              |   |
| 10-4   |        |         |          |        | 3     |           |         |     | I              | 4              |              |     |    | 4   |    |    |           |            |          |              |   |
|        | 11-4   | 11-4    |          | X      | S/2   |           |         |     | I              | 4              |              |     |    | 4   |    |    |           |            |          |              |   |
| 10-5   |        |         |          | X      | X     | P         | P       |     | I              | 5              |              |     |    | 5   |    |    |           |            |          |              |   |
|        | 11-5   | 11-5    | B5       | X      | X     |           |         | P   | I              | 5              |              |     |    | 5   |    |    |           |            |          |              |   |
|        | 11-6■  |         |          | S      |       |           |         |     | I              | 6              |              |     |    | 6   |    |    |           |            |          |              |   |
| 10-13  |        |         |          | X      | X     | P/S       | P/S     |     | M              | 13             |              | 13  |    |     |    |    |           |            |          |              |   |
|        | 11-13  |         |          | X      | X     | P/S       | P/S     |     | M              | 13             |              | 13  |    |     |    |    |           |            |          |              |   |
| 10-35  |        |         |          |        | X     | P/S       | P/S     |     | M              | 13             | 13           |     |    |     |    |    |           |            |          |              |   |
|        | 11-35  | 11-35   | B35      |        | X     | P/S       | P/S     | P   | M              | 13             |              |     |    |     |    |    |           |            |          |              |   |
|        |        | 11-54 ■ |          |        | X     | ◆         |         |     | II             | 4              | 4            |     |    |     |    |    |           |            |          |              |   |
| 10-98  |        |         |          | X      | X     | P/S       | P/S     |     | I              | 6              |              |     |    | 6   |    |    |           |            |          |              |   |
|        | 11-98  | 11-98   | B98      | X      | X     | P/S       | P/S     | P   | I              | 6              |              |     |    | 6   |    |    |           |            |          |              |   |
| 10-99  |        |         |          |        | X     | P         | P       |     | I              | 7              |              |     |    | 7   |    |    |           |            |          |              |   |
|        | 11-99  | 11-99   | B99      |        | P     | X         |         | P   | I              | 7              |              |     |    | 7   |    |    |           |            |          |              |   |
| 12-3   |        |         |          | X      | X     | ◆         | P       | P   | II             | 3              |              |     |    |     | 3  |    |           |            |          |              |   |
|        | 13-3■  |         |          |        | P     |           |         |     | II             | 3              |              |     |    |     | 3  |    |           |            |          |              |   |
| 12-4   |        |         |          | X      | X     | P         | P       |     | I              | 4              |              |     |    | 4   |    |    |           |            |          |              |   |
|        | 13-4★  | 13-4★   | C4       | X      | X     | P         | P       | P   | I              | 4              |              |     |    | 4   |    |    |           |            |          |              |   |
| 12-8   |        |         |          | X      | X     | P         | P       |     | I              | 8              |              |     |    | 8   |    |    |           |            |          |              |   |
|        | 13-8   | 13-8    | C8       | X      | X     | P         | P       | P   | I              | 8              |              |     |    | 8   |    |    |           |            |          |              |   |
|        |        | 13-13■  |          |        |       |           |         |     | I, Fiber Optic | 4              |              |     |    | 2** | 2  |    |           |            |          |              |   |
| 12-22  |        |         |          |        | X     | P/S       | P/S     |     | M              | 22             |              | 22  |    |     |    |    |           |            |          |              |   |
|        | 13-22  |         |          | X      | X     | P/S       | P/S     |     | M              | 22             |              | 22  |    |     |    |    |           |            |          |              |   |
| 12-35  |        |         |          |        | X     | P/S       | P/S     |     | M              | 22             | 22           |     |    |     |    |    |           |            |          |              |   |
|        | 13-35  | 13-35   | C35      |        | X     | P/S       | P/S     | P   | M              | 22             |              |     |    |     |    |    |           |            |          |              |   |
|        |        | 13-63■  |          |        | ◆     |           |         |     | I              | 4              |              |     |    | 2   | 2  |    |           |            |          |              |   |
| 12-98  |        |         |          | X      | X     | P/S       | P/S     |     | I              | 10             |              |     | 10 |     |    |    |           |            |          |              |   |
|        | 13-98  | 13-98   | C98      | X      | X     | P/S       | P/S     | P   | I              | 10             |              |     | 10 |     |    |    |           |            |          |              |   |
| 14-4■  |        |         |          |        | 2     |           |         |     | I              | 4              |              |     |    |     | 4  |    |           |            |          |              |   |
|        | 15-4■  | 15-4■   |          |        | 2     | ◆         |         |     | I              | 4              |              |     |    |     | 4  |    |           |            |          |              |   |
| 14-5   |        |         |          | X      | X     | P         | P       |     | II             | 5              |              |     |    | 5   |    |    |           |            |          |              |   |
|        | 15-5★  | 15-5★   | D5       | X      | X     | P         | P       | P   | II             | 5              |              |     |    | 5   |    |    |           |            |          |              |   |
| 14-15  |        |         |          | X      | X     | P         | P       |     | I              | 15             |              |     | 14 | 1   |    |    |           |            |          |              |   |
|        | 15-15  | 15-15   | D15      | X      | X     | P/S       | P/S     | P   | I              | 15             |              |     | 14 | 1   |    |    |           |            |          |              |   |

X Completely tooled.  
 • Majority of tooling is completed (contact Amphenol Aerospace for availability).  
 ◆ Not tooled for 02-R.  
 P Available with Pin contacts only  
 S Available with Socket contacts only  
 P/S Available with Pin contacts or Socket contacts  
 ★ Ground plane proprietary option available. Arrg. 9-5 is exclusively ground plane type.  
 ■ Not Mil-Qualified.  
 ◆ 21-75 is Mil-Qualified with twinax contacts only.  
 Note: MS connector 21-75 is supplied with size 8 twinax.  
 Commercial connector 21-75 is supplied with size 8 coax.

\* Hermetic inserts - solder termination standard. (Contact Amphenol Aerospace for optional PCB or eyelet termination).  
 \*\* Two size 16 contacts dedicated to fiber optics. See the Fiber Optic section for more information.  
 \*\*\* For use in MIL-STD-1760 applications (see pages 40 & 41).  
 † For RG 180/U and RG 195/U cables only.  
 †† Size 8 Coax and Twinax are interchangeable.  
 (2) Not Tooled for RP or 02RE  
 (3) Pin inserts only, not tooled for RP or 02RE (Consult Sidney, NY for avail.)  
 (5) MS Connector 21-79 has provision for two size 8 coax contacts.  
 Coax contacts are not supplied unless specified by customer.







# MIL-DTL-38999, Series I LJT, II JT, III TV Insert Availability and Identification Chart



| Series | Series | Series | Military | JT/LJT | Hermetics |   |   |     |                | Contact Size   |     |     |    |    |    |    |           |            |          |              |           |
|--------|--------|--------|----------|--------|-----------|---|---|-----|----------------|----------------|-----|-----|----|----|----|----|-----------|------------|----------|--------------|-----------|
| JT II  | LJT I  | TV III | TV III   | Solder | Crimp     | H | Y | TV* | Service Rating | Total Contacts | 22D | 22M | 22 | 20 | 16 | 12 | 12 (Coax) | 10 (Power) | 8 (Coax) | 8†† (Twinax) | 8 Quadrax |
| 24-35  |        |        |          |        | X         | P | P |     | New            | 128            | 128 |     |    |    |    |    |           |            |          |              |           |
|        | 25-35  | 25-35  | J35      |        | X         | P | P | P   | M              |                |     |     |    |    |    |    |           |            |          |              |           |
| 24-37  |        |        |          |        | X         |   |   |     | I              | 37             |     |     |    | 37 |    |    |           |            |          |              |           |
|        | 25-37★ | 25-37★ | J37      |        | X         |   |   |     | I              |                |     |     |    |    |    |    |           |            |          |              |           |
| 24-43  |        |        |          |        | 3         |   |   |     | I              | 43             |     |     |    | 23 | 20 |    |           |            |          |              |           |
|        | 25-43  | 25-43  | J43      | X      | 2         | ♦ |   |     | I              |                |     |     |    |    |    |    |           |            |          |              |           |
|        | 25-46  | 25-46  | J46      |        | 2         | ♦ |   |     | I              | 46             |     |     |    | 40 | 4  |    |           |            | 2        |              |           |
| 24-61  |        |        |          |        | X         | X | P | P   | I              |                |     |     |    |    |    |    |           |            |          |              |           |
|        | 25-61  | 25-61  | J61      | X      | X         | P | P | P   | I              | 61             |     |     |    | 61 |    |    |           |            |          |              |           |
|        | 25-62  | 25-62  |          |        | X         | ♦ |   |     | I              |                |     |     |    |    |    |    |           |            |          |              |           |
|        | 25-90  | J90    |          |        | ♦         |   |   |     | I              | 46             |     |     |    | 40 | 4  |    |           |            |          | 2            |           |
|        | 25-F4  |        |          |        | X         |   |   |     | M/I            |                |     |     |    |    |    |    |           |            |          |              |           |
|        |        |        |          |        |           |   |   |     |                | 66             | 49  |     |    |    | 13 | 4  |           |            |          |              |           |

- X Completely tooled.
- ♦ Not tooled for 02-R.
- P Pin inserts only (contact Amphenol Aerospace for socket availability).
- ★ Ground plane proprietary option available. Arrg. 9-5 is exclusively ground plane type.
- Not Mil-Qualified.

## TV Series III

### Select Shell Size - Special Insert Arrangement

(Not Mil-Spec Qualified)

| Shell Size-Insert Arrg. | Crimp | Hermetics* | Service Rating | Total Contacts | Comments         | Contact Size |    |    |    |
|-------------------------|-------|------------|----------------|----------------|------------------|--------------|----|----|----|
|                         |       |            |                |                |                  | 22D          | 20 | 16 | 12 |
| 9-2                     | X     |            | I              | 2              | Formerly Pyle    |              | 2  |    |    |
| 15-4                    | X     |            | II             | 4              | Formerly Pyle    |              |    | 4  |    |
| 15-25                   | X     |            | M              | 25             | Formerly Pyle    | 22           |    | 3  |    |
| 17-20                   | X     |            | M              | 20             | Formerly Pyle    |              | 16 | 4  |    |
| 21-12                   | X     |            | I              | 12             | Formerly Pyle    |              | 3  |    | 9  |
| 21-21                   | X     |            | M/Inst.        | 41             | Improved sealing | 32           |    |    | 9  |
| 21-99                   | X     |            | M              | 16             | Formerly Pyle    | 5            |    |    | 11 |
| 25-92                   | X     |            | M              | 101            | Formerly Pyle    | 92           |    | 9  |    |
| 25-97                   | X     |            | M              | 42             | Formerly Pyle    | 26           |    | 3  | 13 |

## Select Non-Standard Shell Size

### - Special Insert Arrangement

| Shell Size-Insert Arrg. | Crimp | Hermetics* | Service Rating | Total Contacts | Contact Size |   |   |   |
|-------------------------|-------|------------|----------------|----------------|--------------|---|---|---|
|                         |       |            |                |                | 20           | 8 | 4 | 0 |
| 25-16                   | X     |            | M              | 8              | 6            |   | 2 |   |
| 25L-3                   | X     |            | II             | 3              |              | 1 | 2 |   |
| 25L-7                   | X     |            | II             | 7              |              | 7 |   |   |
| 33-3                    | X     |            | II             | 3              |              |   | 1 | 2 |
| 33-5                    | X     |            | II             | 5              |              |   | 5 |   |
| 33-6                    | X     |            | II             | 6              |              | 2 | 4 |   |
| 37-5                    | X     |            | II             | 4              |              |   |   | 4 |

(Insert arrangements requiring non-standard shells or larger contacts)

- X Completely tooled.
- Majority of tooling is completed (contact Amphenol Aerospace for availability).
- ♦ Not tooled for 02-R.
- P Pin inserts only (contact Amphenol Aerospace for socket availability).
- ★ Ground plane proprietary option available. Arrangement 9-5 is exclusively ground plane type.
- Not Mil-Qualified.
- \* Hermetic inserts - solder termination standard. (Contact Amphenol Aerospace for optional PCB or eyelet termination).
- \*\* Two size 16 contacts dedicated to fiber optics. See the Fiber Optic section for more information.
- \*\*\* For use in MIL-STD-1760 applications (pgs. 40 & 41).
- † For RG 180/U and RG 195/U cables only.
- †† Size 8 Coax and Twinax are interchangeable.
- Note: 25L-3 and 25L-7 require longer shells.

III **38999**  
II **SJT**

Matrix 2 **26482**

Matrix **83723 III**  
Pyle

Crimp Rear Release Matrix **5015**

26500 Pyle

Printed Circuit Board

EMI Filter Transient

Fiber Optics

High Speed Contacts

Options Others

Front face of pin inserts illustrated

|                          |                                |     |          |     |     |      |      |      |      |      |
|--------------------------|--------------------------------|-----|----------|-----|-----|------|------|------|------|------|
| 38999<br>SJT<br>Matrix 2 | Shell Size & Insert Arrg. for: |     |          |     |     |      |      |      |      |      |
|                          | <b>Series II JT</b>            | 8-2 | 8-3      | 8-6 |     |      | 8-35 | 8-44 | 8-97 | 8-98 |
|                          | <b>Series I LJT</b>            |     | 9-3      | 9-6 | 9-7 | 9-22 | 9-35 | 9-44 |      | 9-98 |
|                          | <b>Series III TV</b>           |     |          | 9-5 |     |      | 9-35 |      | 9-94 | 9-98 |
| Service Rating           | M                              | M   | Grounded | M   | M   | I    | M    | M    | M    | I    |
| Number of Contacts       | 2                              | 3   | 1        | 6   | 7   | 2    | 6    | 4    | 2    | 2    |
| Contact Size             | 20                             | 20  | 8 Twinax | 22M | 22M | 20   | 22D  | 22   | 20   | 22M  |

|                          |                                |      |      |      |      |       |       |       |       |       |
|--------------------------|--------------------------------|------|------|------|------|-------|-------|-------|-------|-------|
| 83723 III<br>Matrix Pyle | Shell Size & Insert Arrg. for: |      |      |      |      |       |       |       |       |       |
|                          | <b>Series II JT</b>            |      | 10-4 | 10-5 |      | 10-13 | 10-35 |       | 10-98 | 10-99 |
|                          | <b>Series I LJT</b>            | 11-2 | 11-4 | 11-5 | 11-6 | 11-13 | 11-35 |       | 11-98 | 11-99 |
|                          | <b>Series III TV</b>           | 11-2 | 11-4 | 11-5 |      |       | 11-35 | 11-54 | 11-98 | 11-99 |
| Service Rating           | I                              | I    | I    | I    | M    | M     | II    | I     | I     | II    |
| Number of Contacts       | 2                              | 4    | 5    | 6    | 13   | 13    | 4     | 6     | 7     | 3     |
| Contact Size             | 16                             | 20   | 20   | 20   | 22M  | 22D   | 22D   | 20    | 20    | 16    |

|                                      |  |                                |      |      |       |       |       |       |      |      |       |
|--------------------------------------|--|--------------------------------|------|------|-------|-------|-------|-------|------|------|-------|
| 5015<br>Crimp Rear<br>Release Matrix | 26500 Pyle<br>Printed<br>Circuit Board | Shell Size & Insert Arrg. for: |      |      |       |       |       |       |      |      |       |
|                                      |  | <b>Series II JT</b>            | 12-4 | 12-8 | 12-22 | 12-35 |       | 12-98 | 14-4 | 14-5 | 14-15 |
|                                      |  | <b>Series I LJT</b>            | 13-4 | 13-8 | 13-22 | 13-35 |       | 13-98 | 15-4 | 15-5 | 15-15 |
|                                      |  | <b>Series III TV</b>           | 13-4 | 13-8 | 13-22 | 13-35 | 13-63 | 13-98 | 15-4 | 15-5 | 15-15 |
| Service Rating                       | I                                      | I                              | M    | M    | I     | I     | I     | II    | II   | I    |       |
| Number of Contacts                   | 4                                      | 8                              | 22   | 22   | 2     | 2     | 10    | 4     | 5    | 14   | 1     |
| Contact Size                         | 16                                     | 20                             | 22M  | 22D  | 16    | 12    | 20    | 12    | 16   | 20   | 16    |

|                         |              |                                |       |       |       |       |       |       |          |      |
|-------------------------|--------------|--------------------------------|-------|-------|-------|-------|-------|-------|----------|------|
| EMI Filter<br>Transient | Fiber Optics | Shell Size & Insert Arrg. for: |       |       |       |       |       |       |          |      |
|                         |              | <b>Series II JT</b>            | 14-18 | 14-19 | 14-35 | 14-37 | 14-68 | 14-97 |          | 17-2 |
|                         |              | <b>Series I LJT</b>            | 15-18 | 15-19 | 15-35 | 15-37 | 15-68 | 15-97 |          | 17-2 |
|                         |              | <b>Series III TV</b>           | 15-18 | 15-19 | 15-35 |       |       | 15-97 |          | 17-2 |
| Service Rating          | I            | I                              | M     | M     | I     | I     | I     | M     |          |      |
| Number of Contacts      | 18           | 19                             | 37    | 37    | 8     | 8     | 4     | 38    | 1        |      |
| Contact Size            | 20           | 20                             | 22D   | 22M   | 16    | 20    | 16    | 22D   | 8 Twinax |      |

|                        |                   |                                |      |         |        |       |        |       |
|------------------------|-------------------|--------------------------------|------|---------|--------|-------|--------|-------|
| High Speed<br>Contacts | Options<br>Others | Shell Size & Insert Arrg. for: |      |         |        |       |        |       |
|                        |                   | <b>Series II JT</b>            | 16-6 | 16-8    | 16-13  |       |        | 16-26 |
|                        |                   | <b>Series I LJT</b>            | 17-6 | 17-8    | 17-13  | 17-22 | 17-25  | 17-26 |
|                        |                   | <b>Series III TV</b>           | 17-6 | 17-8    |        | 17-22 |        | 17-26 |
| Service Rating         | I                 | II                             | I    | Coax    | M      | I     |        |       |
| Number of Contacts     | 6                 | 8                              | 13   | 2       | 2      | 22    | 2      |       |
| Contact Size           | 12                | 16                             | 16   | 12 Coax | 8 Coax | 22D   | 8 Coax | 20    |

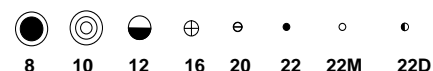

# MIL-DTL-38999, Series I LJT, II JT, III TV Insert Arrangements



Front face of pin inserts illustrated

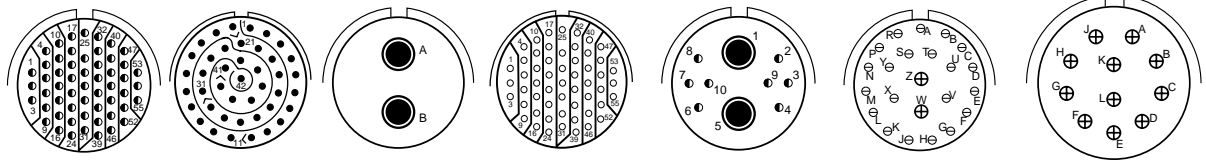

Shell Size & Insert Arrg. for:

|                      |       |       |          |        |        |
|----------------------|-------|-------|----------|--------|--------|
| <b>Series II JT</b>  | 16-35 | 16-42 | 16-55    | 16-99  | 18-11  |
| <b>Series I LJT</b>  | 17-35 | 17-42 | 17-55    | 17-99  | 19-11  |
| <b>Series III TV</b> | 17-35 |       | 17-52    | 17-60  | 17-99  |
| Service Rating       | M     | M     | M        | I/Coax | I      |
| Number of Contacts   | 55    | 42    | 55       | 8      | 2      |
| Contact Size         | 22D   | 22    | 8 Twinax | 22D    | 8 Coax |



Shell Size & Insert Arrg. for:

|                      |       |          |       |       |
|----------------------|-------|----------|-------|-------|
| <b>Series II JT</b>  | 18-28 | 18-30    | 18-32 | 18-35 |
| <b>Series I LJT</b>  | 19-18 | 19-28    | 19-32 | 19-35 |
| <b>Series III TV</b> | 19-18 | 19-28    | 19-31 | 19-35 |
| Service Rating       | M     | M        | I     | M     |
| Number of Contacts   | 14    | 4        | 26    | 2     |
| Contact Size         | 22D   | 8 Twinax | 20    | 18    |



Shell Size & Insert Arrg. for:

|                      |       |       |       |       |
|----------------------|-------|-------|-------|-------|
| <b>Series II JT</b>  | 18-53 | 18-66 | 18-68 | 18-96 |
| <b>Series I LJT</b>  | 19-53 | 19-66 | 19-67 | 19-68 |
| <b>Series III TV</b> |       |       |       |       |
| Service Rating       | M     | M     | M     | I     |
| Number of Contacts   | 53    | 66    | 67    | 18    |
| Contact Size         | 22    | 22M   | 22M   | 16    |



Shell Size & Insert Arrg. for:

|                      |       |          |       |       |
|----------------------|-------|----------|-------|-------|
| <b>Series II JT</b>  | 20-1  | 20-2     | 20-11 | 20-16 |
| <b>Series I LJT</b>  | 21-1  | 21-2     | 21-11 | 21-16 |
| <b>Series III TV</b> | 19-AD |          | 21-11 | 21-16 |
| Service Rating       | Inst. | M        | M     | I     |
| Number of Contacts   | 16    | 1        | 79    | 65    |
| Contact Size         | 20    | 8 Twinax | 22M   | 22    |



CONTACT LEGEND

38999  
SJT

26482  
Matrix 2

83723 III  
Matrix Pyle

5015  
Crimp Rear Release Matrix

26500 Pyle

Printed  
Circuit Board

EMI Filter  
Transient

Fiber Optics

High Speed  
Contacts

Options  
Others



Front face of pin inserts illustrated



Shell Size &  
Insert Arrg. for:

|                    | Series II JT |    | Series I LJT |    |    | Series III TV |     |  |
|--------------------|--------------|----|--------------|----|----|---------------|-----|--|
| Service Rating     | I            | I  | I            | I  | I  | M             | M   |  |
| Number of Contacts | 25           | 27 | 19           | 4  | 4  | 79            | 79  |  |
| Contact Size       | 20           | 20 | 20           | 16 | 12 | 22D           | 22D |  |



Shell Size &  
Insert Arrg. for:

|                    | Series II JT |    | Series I LJT |            | Series III TV |     |
|--------------------|--------------|----|--------------|------------|---------------|-----|
| Service Rating     | I            | I  | N            | II         | M             | M   |
| Number of Contacts | 37           | 2  | 41           | 4          | 17 (See Note) | 100 |
| Contact Size       | 20           | 16 | 20           | (See Note) | 22D           | 22M |

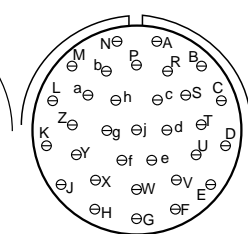
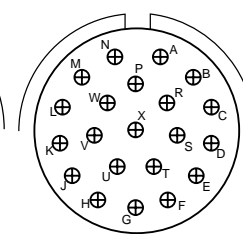
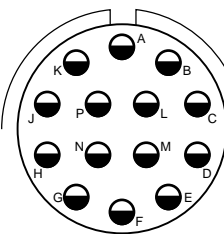

Shell Size &  
Insert Arrg. for:

|                    | Series II JT |          | Series I LJT |    | Series III TV |    |
|--------------------|--------------|----------|--------------|----|---------------|----|
| Service Rating     | M            | M        | I            | II | I             | I  |
| Number of Contacts | 85           | 6        | 14           | 21 | 32            | 32 |
| Contact Size       | 22           | 8 Twinax | 12           | 16 | 20            | 20 |

**Note:** MS connector 21-75 is supplied with four size 8 twinax contacts.  
Commercial connector 21-75 is supplied with four size 8 coax contacts.  
MS connector 21-79 has provision for two size 8 coax contacts.  
Coax contacts are not supplied unless specified by customers.



Front face of pin inserts illustrated



Shell Size & Insert Arrg. for:

|                      |              |              |              |                  |
|----------------------|--------------|--------------|--------------|------------------|
| <b>Series II JT</b>  |              | <b>22-35</b> | <b>22-53</b> |                  |
| <b>Series I LJT</b>  | <b>23-34</b> | <b>23-35</b> | <b>23-53</b> |                  |
| <b>Series III TV</b> |              | <b>23-35</b> | <b>23-53</b> | <b>23-54</b>     |
| Service Rating       | <b>I</b>     | <b>M</b>     | <b>I</b>     | <b>M</b>         |
| Number of Contacts   | <b>34</b>    | <b>100</b>   | <b>53</b>    | <b>40 9 4</b>    |
| Contact Size         | <b>20</b>    | <b>22D</b>   | <b>20</b>    | <b>22D 16 12</b> |



Shell Size & Insert Arrg. for:

|                      |              |              |              |             |
|----------------------|--------------|--------------|--------------|-------------|
| <b>Series II JT</b>  | <b>22-55</b> |              |              | <b>24-1</b> |
| <b>Series I LJT</b>  | <b>23-55</b> | <b>23-97</b> | <b>23-99</b> | <b>25-1</b> |
| <b>Series III TV</b> | <b>23-55</b> |              |              |             |
| Service Rating       | <b>I</b>     | <b>II</b>    | <b>II</b>    | <b>M</b>    |
| Number of Contacts   | <b>55</b>    | <b>16</b>    | <b>11</b>    | <b>128</b>  |
| Contact Size         | <b>20</b>    | <b>16</b>    | <b>16</b>    | <b>22M</b>  |



Shell Size & Insert Arrg. for:

|                      |             |              |                     |                 |
|----------------------|-------------|--------------|---------------------|-----------------|
| <b>Series II JT</b>  | <b>24-2</b> | <b>24-4</b>  |                     |                 |
| <b>Series I LJT</b>  | <b>25-2</b> | <b>25-4</b>  | <b>25-7</b>         |                 |
| <b>Series III TV</b> |             | <b>25-4</b>  | <b>25-7</b>         | <b>25-8</b>     |
| Service Rating       | <b>M</b>    | <b>I</b>     | <b>M</b>            | <b>Twinax</b>   |
| Number of Contacts   | <b>100</b>  | <b>48 8</b>  | <b>97 2</b>         | <b>8</b>        |
| Contact Size         | <b>22</b>   | <b>20 16</b> | <b>22D 8 Twinax</b> | <b>8 Twinax</b> |

\*\*\* For use in MIL-STD-1760 applications (see pages 40 and 41).



**CONTACT LEGEND** 8 10 12 16 20 22D

**38999**  
SJT

**26482**  
Matrix 2

**83723 III**  
Matrix Pyle

**5015**  
Crimp Rear Release Matrix

**26500 Pyle**

**Printed**  
Circuit Board

**EML Filter**  
Transient

**Fiber Optics**

**High Speed**  
Contacts

**Options**  
Others

Front face of pin inserts illustrated



Shell Size & Insert Arrg. for:

| Series II JT       | 24-19    | 25-19        | 25-20                  |
|--------------------|----------|--------------|------------------------|
| Series I LJT       | 25-11    | 25-19        | 25-20                  |
| Series III TV      | 25-11*** | 25-17        | 25-20***               |
| Service Rating     | N        | I            | N                      |
| Number of Contacts | 2 9      | 36 6         | 10 13 3 4              |
| Contact Size       | 20 10    | 22D 8 Twinax | 20 16 8 Twinax 12 Coax |

(With Matched Impedance)

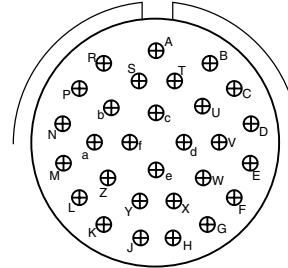

Shell Size & Insert Arrg. for:

| Series II JT       | 24-24 | 24-29        | 24-35  |
|--------------------|-------|--------------|--------|
| Series I LJT       | 25-24 | 25-29        | 25-35  |
| Series III TV      | 25-24 | 25-26        | 25-35  |
| Service Rating     | I     | I            | M      |
| Number of Contacts | 12 12 | 16 5 4       | 29 128 |
| Contact Size       | 16 12 | 20 12 8 Coax | 16 22D |

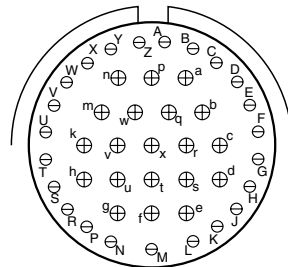

Shell Size & Insert Arrg. for:

| Series II JT       | 24-37 | 25-43 | 25-46        |
|--------------------|-------|-------|--------------|
| Series I LJT       | 25-37 | 25-43 | 25-46        |
| Series III TV      | 25-37 | 25-43 | 25-46        |
| Service Rating     | I     | I     | I            |
| Number of Contacts | 37    | 23 20 | 40 4 2       |
| Contact Size       | 16    | 20 16 | 20 16 8 Coax |

† Coax contacts for RG180/U or RG195/U cable.

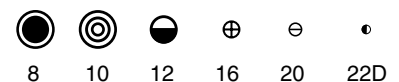



# MIL-DTL-38999, Series I LJT, II JT, III TV Insert Arrangements



Front face of pin inserts illustrated



Shell Size & Insert Arr. for:

**Series II JT** 24-61

**Series I LJT** 25-61

**Series III TV** 25-61

|                    | 25-62 |      | 25-90          |           |                        | 25-F4 |  |  |
|--------------------|-------|------|----------------|-----------|------------------------|-------|--|--|
| Service Rating     | I     | I    | I              | I         | Size 22D=M, Balance =I |       |  |  |
| Number of Contacts | 61    | 8 4  | 40 4 2         | 49 13 4   |                        |       |  |  |
| Contact Size       | 20    | 16 8 | 20 16 8 Twinax | 22D 16 12 |                        |       |  |  |

## MIL-DTL-38999, Series III TV

### Special Insert Arrangements

Front face of socket inserts illustrated



Shell Size & Insert Arr. for:

**Series III TV** 9-2

**Series III TV** 15-4\*

**Series III TV** 15-25

**Series III TV** 17-20

**Series III TV** 21-12

**Series III TV** 21-21

|                    | 15-4* |    | 15-25  |        | 17-20 |        | 21-12 |  | 21-21   |  |
|--------------------|-------|----|--------|--------|-------|--------|-------|--|---------|--|
| Service Rating     | I     | II | M      |        | M     |        | I     |  | M/Inst. |  |
| Number of Contacts | 2     | 4  | 22 3   | 16 4   | 3 9   | 32 9   |       |  |         |  |
| Contact Size       | 20    | 16 | 22D 16 | 22D 12 | 20 12 | 22D 12 |       |  |         |  |

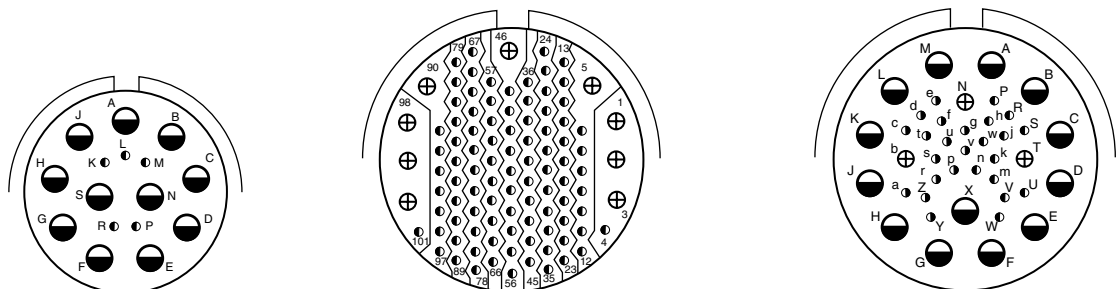

Shell Size & Insert Arr. for:

**Series III TV** 21-99

**Series III TV** 25-92

**Series III TV** 25-97

|                    | 21-99  |        | 25-92     |  | 25-97 |  |  |
|--------------------|--------|--------|-----------|--|-------|--|--|
| Service Rating     | M      |        | M         |  | M     |  |  |
| Number of Contacts | 5 11   | 92 9   | 26 3 13   |  |       |  |  |
| Contact Size       | 22D 12 | 22D 16 | 22D 16 12 |  |       |  |  |

NOTE: Some specials shown here were formerly known as Pyle arrangements. Consult Amphenol for how to order information for connectors with these inserts. For further information on special arrangements consult Amphenol Aerospace, Sidney NY.

\* Pyle 15-4 does not mate with Amphenol Tri-Start 15-4 insert.



CONTACT LEGEND

- III 38999
- II I SJT
- Matrix 2 26482
- Matrix 83723 III
- Pyle 5015
- Crimp Rear Release Matrix 26500 Pyle
- Printed Circuit Board
- EMI Filter Transient
- Fiber Optics
- High Speed Contacts
- Options Others

Front face of pin inserts illustrated

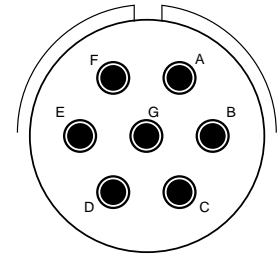
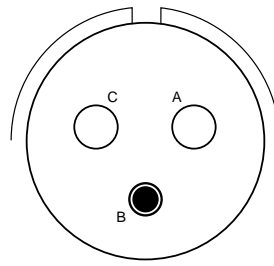
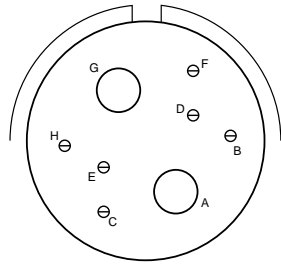

Shell Size & Insert Arrg. for:

| Series III TV      | 25-16 | 25L-3 | 25L-7 |
|--------------------|-------|-------|-------|
| Service Rating     | M     | II    | II    |
| Number of Contacts | 6 2   | 1 2   | 7     |
| Contact Size       | 20 4  | 8 4   | 8     |

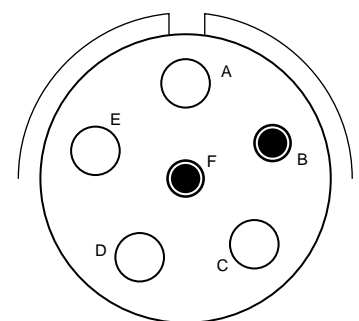
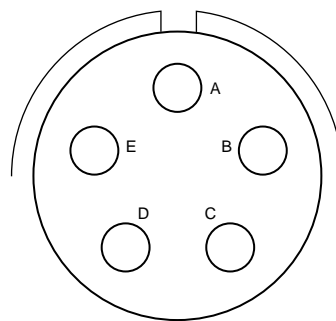
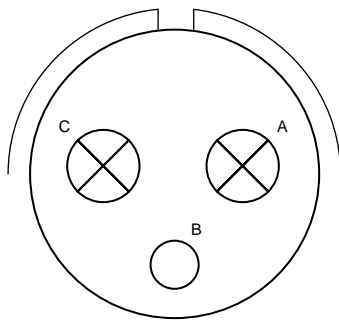

Shell Size & Insert Arrg. for:

| Series III TV      | 33-3 | 33-5 | 33-6 |
|--------------------|------|------|------|
| Service Rating     | II   | II   | II   |
| Number of Contacts | 1 2  | 5    | 2 4  |
| Contact Size       | 4 0  | 4    | 8 4  |

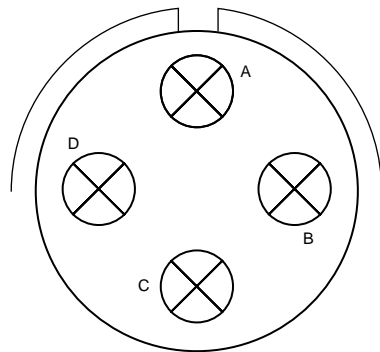

Shell Size & Insert Arrg. for:

| Series III TV      | 37-5 |
|--------------------|------|
| Service Rating     | II   |
| Number of Contacts | 4    |
| Contact Size       | 0    |

NOTE: Some specials shown here were formerly known as Pyle arrangements. Consult Amphenol for how to order information for connectors with these inserts.

Consult Amphenol Aerospace for longer shell drawings.

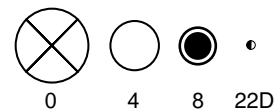

CONTACT LEGEND

- III
- SJT 38999 I II
- 26482 Matrix 2
- 83723 III Pyle Matrix
- 5015 Crimp Rear Release Matrix
- 26500 Pyle
- Printed Circuit Board
- EMI Filter Transient
- Contacts Fiber Optics
- ries
- Options Others

## CONTACT RATING

| Contact Size | Test Current (Amps) |          | Maximum Millivolt Drop Crimp* | Maximum Millivolt Drop |           | Contact Size | Crimp Well Data |                   | Solder Well Data    |                    |
|--------------|---------------------|----------|-------------------------------|------------------------|-----------|--------------|-----------------|-------------------|---------------------|--------------------|
|              | Crimp               | Hermetic |                               | Solder*                | Hermetic* |              | Well Diameter   | Normal Well Depth | Well Diameter       | Nominal Well Depth |
| 22M          | 3                   | 2        | 45                            | 20                     | 60        | 22M          | .028 ± .001     | .141              | .029 +.004<br>-.000 |                    |
| 22D          | 5                   | 3        | 73                            |                        | 85        | 22D          | .0345 ± .0010   | .141              | .036 +.004<br>-.000 | .094               |
| 22           | 5                   | 3        | 73                            | 20                     | 85        | 22           | .0365 ± .0010   | .141              | .036 +.004<br>-.000 | .094               |
| 20           | 7.5                 | 5        | 55                            | 20                     | 60        | 20           | .047 ± .001     | .209              | .044 +.004<br>-.004 | .125               |
| 16           | 13                  | 10       | 49                            | 20                     | 85        | 16           | .067 ± .001     | .209              | .078 +.000<br>-.004 | .141               |
| 12           | 23                  | 17       | 42                            | 20                     | 85        | 12           | .100 ± .002     | .209              | .116 +.004<br>-.002 | .141               |
| 10 (Power)   | 33                  | NA       | 33                            | NA                     | NA        | 10 (Power)   | .137 ± .002     | .355              | NA                  | NA                 |
| 8 (Power)    | 46                  | NA       | 26                            | NA                     | NA        | 8            | .181 ± .002     | .490              | NA                  | NA                 |
| 4            | 80                  | NA       | 23                            | NA                     | NA        | 4            | .281 ± .002     | .490              | NA                  | NA                 |
| 0            | 150                 | NA       | 21                            | NA                     | NA        | 0            | .453 ± .002     | .585              | NA                  | NA                 |

\*When tested using silver plated wire.

## SERVICE RATING\*\*

| Service Rating | Suggested Oper. Voltage (Sea Level) |      | Test Voltage (Sea Level) | Test Voltage 50,000 Ft. | Test Voltage 70,000 Ft. | Test Voltage 110,000 Ft. |
|----------------|-------------------------------------|------|--------------------------|-------------------------|-------------------------|--------------------------|
|                | AC (RMS)                            | DC   |                          |                         |                         |                          |
| M              | 400                                 | 500  | 1300 VRMS                | 550 VRMS                | 350 VRMS                | 200 VRMS                 |
| N              | 300                                 | 450  | 1000 VRMS                | 400 VRMS                | 260 VRMS                | 200 VRMS                 |
| I              | 600                                 | 850  | 1800 VRMS                | 600 VRMS                | 400 VRMS                | 200 VRMS                 |
| II             | 900                                 | 1250 | 2300 VRMS                | 800 VRMS                | 500 VRMS                | 200 VRMS                 |

\*\*Please note that the establishment of electrical safety factors is left entirely in the designer's hands, since he is in the best position to know what peak voltage, switching surges, transients, etc. can be expected in a particular circuit.

## MIL-DTL-38999 Series III STANDARD 500 CYCLE CONTACTS FOR TV AND CTV, P & S

| Contact Size | TV/CTV Pins     |             | TV/CTV Sockets |             |
|--------------|-----------------|-------------|----------------|-------------|
|              | Military No.    | Supersedes  | Military No.   | Supersedes  |
| 8 (Coax)*    | M39029/60-367   | MS27536     | M39029/59-366  | MS27535     |
| 8 (Power)    | Contact Factory | "           | "              | "           |
| 8 (Twinax)   | M39029/90-529** | N/A         | M39029/91-530  | N/A         |
| 10 (Power)   | M39029/58-528   | N/A         | M39029/56-527  | N/A         |
| 12           | M39029/58-365   | MS27493-12  | M39029/56-353  | MS27490-12  |
| 16           | M39029/58-364   | MS27493-16  | M39029/56-352  | MS27490-16  |
| 20           | M39029/58-363   | MS27493-20  | M39029/56-351  | MS27490-20  |
| 22D          | M39029/58-360   | MS27493-22D | M39029/56-348  | MS27490-22D |
| 4            | N/A             | N/A         | N/A            | N/A         |
| 0            | N/A             | N/A         | N/A            | N/A         |

\*\* For use with M17/M176-00002 cable.

† Optional design - see slash sheet MS39029.

For other contact options available for use in Tri-Start connectors, (wire wrap, thermocouple, fiber optic) consult Amphenol. Wire wrap data given on next page.

Above part numbers include standard 500 cycle finish designation - gold plating over suitable underplate in accordance with SAE AS39029. For other finish variations, consult Sidney, NY.

\*For use with RG180B/U and RG195A/U cable. For other size 8 coax or optional sizes 12 and 16 coax contacts available for use in Tri-Start connectors, see High Speed Contact section of this catalog or consult Amphenol, Sidney, NY.

## MIL-DTL-38999 Series III 1500 CYCLE CONTACTS FOR CTV, CLASSES H & J

| Contact Size | CTV Pins       |                |            | CTV Sockets    |                |            |
|--------------|----------------|----------------|------------|----------------|----------------|------------|
|              | Commercial No. | Military No.   | Supersedes | Commercial No. | Military No.   | Supersedes |
| 12           | 10-597072-2X   | M39029/107-623 | -          | 10-597073-2X   | M39029/106-617 | -          |
| 16           | 10-597068-2X   | M39029/107-622 | -          | 10-597069-2X   | M39029/106-616 | -          |
| 20           | 10-597064-2X   | M39029/107-621 | -          | 10-597065-2X   | M39029/106-615 | -          |
| 22D          | 10-597058-3X   | M39029/107-620 | -          | 10-597061-2X   | M39029/106-614 | -          |

## MIL-DTL-38999 Series II JT/ Series I LJT CRIMP CONTACTS

| Contact Size | JT/LJT Pins     | JT Socket     | LJT Sockets   | Contact Size | JT/LJT Pins   | JT Socket     | LJT Sockets   |
|--------------|-----------------|---------------|---------------|--------------|---------------|---------------|---------------|
|              | MS No.          | MS No.        | MS No.        |              | MS No.        | MS No.        | MS No.        |
| 8 (Coax)*    | M39029/60-367   | NA            | M39029/59-366 | 20           | M39029/58-363 | M39029/57-357 | M39029/56-351 |
| 8 (Twinax)   | M39029/90-529** | NA            | M39029/91-530 | 22           | M39029/58-362 | M39029/57-356 | M39029/56-350 |
| 10 (Power)   | M39029/58-528   | NA            | M39029/56-527 | 22M          | M39029/58-361 | M39029/57-355 | M39029/56-349 |
| 12           | M39029/58-365   | M39029/57-359 | M39029/56-353 | 22D          | M39029/58-360 | M39029/57-354 | M39029/56-348 |
| 16           | M39029/58-364   | M39029/57-358 | M39029/56-352 |              |               |               |               |

III  
II  
I  
SJT  
38999

Matrix 2  
26482

Matrix  
Pyle  
83723 III

Crimp Rear  
Release Matrix  
5015

Pyle  
26500

Printed  
Circuit Board

EMI Filter  
Transient

Fiber Optics

High Speed  
Contacts

Options  
Others



## FINISH DATA MIL-DTL-38999, Tri-Start Series III TV

| Aluminum Shell Components Non-Hermetic |               |            |
|--|---------------|------------|
| Finish                                 | Service Class |            |
|  | Military      | Commercial |
| Anodic Coating (Non-Conductive)        | C             | RX**       |
| Electroless Nickel                     | F (Metal)     | RF         |
|  | M (Composite) |            |
| Olive Drab Cadmium Plate Nickel Base   | W (Metal)     | RW         |
|  | J (Composite) |            |
| Stainless Steel with Nickel Plate      | S             | RS         |
| Stainless Steel                        | K             | RK         |
| Duralon plated                         | T             | DT         |
| Zinc-Nickel Plated                     | Z             | ZN         |

| Hermetic Shell Components         |               |            |
|-----------------------------------|---------------|------------|
| Material/Finish                   | Service Class |            |
|                                   | Military      | Commercial |
| Stainless Steel                   | Y             | Y          |
| Stainless Steel with Nickel Plate | N             | YN         |

\*\*Add Suffix (005) to part number.

## FINISH DATA MIL-DTL-38999, Series I LJT, II JT

| Aluminum Shell Components Non-Hermetic |          |            |                         |   |  |
|--|----------|------------|-------------------------|---|--|
| Finish                                 | Suffix   |            |                         | Indicated Finish Standard for JT Types Listed Below | Indicated Finish Standard for LJT Types Listed Below |
|  | Military | Commercial | Finish Plus "SR" Suffix |   |  |
| Cadmium Plated Nickel Base             | MS (A)   | -          | (SR)                    | JT/JTG/JTL/JTP                                      | LJT/LJTP   |
| Anodic Coating (Alumilite)             | MS (C)   | (005)      | (300)                   | JTS/JTPS/JTLS                                       | LJTPS/LJTS   |
| Chromate Treated (Iridite 14-2)        |          | (011)      | (344)                   | JTN/JTPN/JTLN                                       | LJTN/LJTPN   |
| Olive Drab Cadmium Plate Nickel Base   | MS (B)   | (014)      | (386)                   |   |  |
| Electroless Nickel                     | MS (F)   | (023)      | (424)                   |   |  |
| Nickel-PTFE                            |          | (038)      |                         |   |  |

| Hermetic Connectors  |          |            |   |  |
|--|----------|------------|---|--|
| Finish   | Suffix   |            | Indicated Finish Standard for JT Types Listed Below | Indicated Finish Standard for LJT Types Listed Below |
|  | Military | Commercial |   |  |
| Carbon Steel Shell<br>Tin Plated Shell and Contacts          |          |            | JT( )H / JT( )Y<br>JTL( )H / JTL( )Y                | LJT( )Y<br>LJT( )H                                   |
| Carbon Steel Shell Tin Plated Shell and Gold Plated Contacts | MS (D)   |            |   |  |
| Stainless Steel Shell Gold Plated Contacts                   | MS (E)   | (162)      | JTS( )Y<br>JTLS( )Y                                 | LJTS( )Y   |

38999

III

SJT

I

II

26482

Matrix 2

83723

III

Pyle

5015

Crimp Rear Release Matrix

26500

Pyle

Printed

Circuit Board

EMI Filter

Transient

Fiber Optics

High Speed

Contacts

Options

Others

# Amphenol MIL-DTL-38999, Series III, TV



**New  
Featured**



**New  
Featured**



## TABLE OF CONTENTS

### Combined MIL-DTL-38999 Series I, II, III

- Shell Size & Insert Arrangements Availability . . . . . 4 -7
- Insert Arrangement Drawings . . . . . 8-14
- Specifications - Contact Ratings, Service Ratings, Finish Data . . . . . 15, 16

### MIL-DTL-38999, Series III TV

- Table of Contents . . . . . 17
- Performance, Options . . . . . 18, 19
- Weight Comparison (Composite vs. Metal) . . . . . 20
- Test Data . . . . . 21
- How to Order (Commercial & Military) . . . . . 22-24
- How to Order (Boeing BACC63) . . . . . 25

### Shell Styles:

- Crimp Wall Mounting Receptacle TVP00R (D38999/20) /CTVP00R (D38999/20) . . . . . 26
- Crimp Box Mounting Receptacle TVP02R / CTVP02R . . . . . 27
- Crimp Straight Plug TV06R (D38999/26) / CTV06R (D38999/26) . . . . . 28
- Crimp CLUTCH-LOK™ Straight Plug for High Vibration TV26/MTV26 . . . . . 29
- Crimp Jam Nut Receptacle TV07R (D38999/24) / CTV07R (D38999/24) . . . . . 30
- Crimp Line Receptacle TV01R / CTV01R . . . . . 31
- Crimp Flange Mounting Plug TV09R . . . . . 32
- Hermetic Box Mounting Receptacle TVPS02Y (D38999/21) . . . . . 33
- Hermetic Jam Nut Receptacle TVS07Y (D38999/23) . . . . . 34
- Hermetic Solder Mounting Receptacle TVSIY (D38999/25),  
Hermetic Weld Mounting Receptacle TVSHIY (D38999/27) . . . . . 35
- Breakaway Fail-Safe Lanyard Release Plug  
D38999/29 & /30 (88-5565 / 91-5565) . . . . . 36, 37
- Breakaway Fail-Safe How to Order (Military/Commercial) . . . . . 38, 39
- Breakaway MIL-STD-1760 Lanyard Release Plug D38999/31 . . . . . 40
- Breakaway MIL-STD-1760 How to Order (Military) . . . . . 41
- Breakaway Hybrid, Low Profile Lanyard Release Plug . . . . . 42
- Stores Management Type II, Rail Launch (MIL-STD-1760) . . . . . 42
- HD38999 (High Density, Crimp) Plugs and Receptacles / How to Order . . . . . 43, 44
- Accessories, Contacts, and Tools see pages . . . . . 89-108



## MIL-DTL-38999 Series III Typical Markets:

- Military & Commercial Aviation
- Military Vehicles
- Missiles & Ordnance
- C4ISR
- Space Applications

**Amphenol**  
Aerospace



**Tri-Start™ MIL-DTL-38999 Series III with Metal Shells - Aluminum, Stainless Steel, Class K Firewall**  
**Amphenol® Tri-Start MIL-DTL-38999\* Series III Connectors offer the highest performance capabilities for both general duty and severe environment applications. Meeting or exceeding MIL-DTL-38999 Series III requirements, the Tri-Start connector with standard metal shells (aluminum or stainless steel with several finish options) offers these features:**

- **EMI Shielding** - solid metal to metal coupling, grounding fingers, electroless nickel plating, and thicker wall sections provide superior EMI shielding capability of 65dB minimum at 10 GHz
- **Contact Protection** - recessed pins in this 100% scoop-proof connector minimize potential contact damage
- **Moisture Resistance** - improved interfacial seal design helps prevent electrolytic erosion of contacts
- **Corrosion Resistance** - shells of stainless steel or cadmium over nickel plating withstand a 500 hour salt spray exposure
- **Vibration/Shock** - operates under severe high temperature vibration, through 200°C
- **Firewall Capability** - available in a stainless steel shell, class RK, RS
- **Lockwiring Eliminated** - unique, self-locking, quick coupling connector eliminates lockwiring
- **Quick Coupling** - completely mates and self-locks in a 360° turn of the coupling nut
- **Inventory Support Commonality** - uses standard MIL-DTL-38999 contacts, application tools, insert arrangements
- **Electrostatic Discharge Protection (ESD)** - protection for sensitive circuitry without diodes, varistors, etc., with the use of the Faraday Cage principle which shunts high voltage, high current discharge events (see page 422)
- **Hermetic** - air leakage limited to  $1 \times 10^{-7} \text{ cm}^3$  per second optional
- **Qualified Specifications** - Stainless Steel qualified to BACC63DB and BACC63DC specifications

**Optional Shell Geometries**  
**Amphenol offers a number of different shell configurations to fit your needs.**

- Deep Reach Shells - For increased panel thickness
- Stand-off Flange Shells - For attachments to Printed Circuit boards.
- Connector with Integral Strain Reliefs

\* MIL-DTL-38999 Series III supersedes MIL-C-38999 Series III.

Applicable Patents:  
 Tri-Start™ Connector Patent 4,109,990.  
 Composite Connector Patents:  
 4,268,103; 4,648,670; 4,682,832; 4,703,987.  
 Clutch-Lok® Patent 6,152,753.



### Series III Composite Tri-Start, Qualified to MIL-DTL-38999, Rev. J

MIL-Qualified to MIL-DTL-38999, Rev. K, the Amphenol® Composite Tri-Start Connector offers a lightweight, corrosion resistant connector with the same high performance features as its metal counterpart. The Composite Tri-Start Connector also includes the following features:

- **Lightweight** - 17% – 70% weight savings (17–40% weight savings vs. Aluminum) (60–70% weight savings vs. Stainless steel) See Composite weight comparison chart on page 20.
- **Corrosion Resistance** - available in standard MIL-DTL-38999 olive drab cadmium (-65°C to 175°C) and electroless nickel plating (-65°C to 200°C), both with standing 2000 hours of salt spray exposure. The base material is able to withstand an indefinite exposure to salt spray.
- **Durability** - 1500 couplings minimum (in reference to connector couplings, not contacts)
- **Extended Life Contact** - Mil-approved plating process which provides 1500 couplings minimum
- Qualified to BACC63CT and BACC63CU specifications



### CLUTCH-LOK™ MIL-DTL-38999 Series III High Vibration Connector

The Tri-Start option CLUTCH-LOK offers all advantages of stainless steel/Class K firewall for MIL-DTL-38999 Series III connectors, plus a unique clutch design that actually tightens itself under vibration.

Features include:

- High degree of differential torque
- No settling back to the next ratchet tooth
- Completely intermateable with all existing MIL-DTL-38999 Series III connectors
- Offers advantage in inaccessible, hard to reach areas where mating torque is difficult to apply and complete coupling is not verifiable by inspection See page 29 for description, 22 – 24 for ordering.

- 38999 SJT I II III
- 26482 Matrix 2
- 83723 III Matrix Pyle
- 5015 Crimp Rear Release Matrix
- 26500 Pyle
- Printed Circuit Board
- EMI Filter Transient
- Fiber Optics
- High Speed Contacts
- Options Others



## Series III, TV Tri-Start Connectors, offer more versatility & options than any other interconnection family!



High reliability and increased versatility best describe Amphenol MIL-DTL-38999, Series III circular connectors. Originally designed for the harshest of environments and most demanding of applications, Amphenol MIL-DTL-38999 Series III, Tri-Start connectors continue to evolve in pace with the needs of an ever-changing market.

Amphenol Tri-Start connectors can be configured with a number of application specific technologies like Filters, Hermetics, PC Tails, Fiber Optics, Flex, CLUTCH-LOK, Fail Safe, and contacts. Flexibility aids in design optimization through the combination of different technologies within a common, time-tested, harsh environment connector body.

For more information about options please call 800-678-0141 or visit [www.amphenol-aerospace.com](http://www.amphenol-aerospace.com).

## Performance

### Designed for Performance

Numerous advantages in performance capability are designed into the Amphenol Tri-Start Connector. A positive metal to metal coupling design, grounding fingers, and electroless nickel plating provide superior EMI shielding capability of 65 dB minimum at 10 GHz.

Acme threads provide coupling durability. Thicker wall sections and a greater coupling surface area improve strength and shock resistance. Blunting of the thread on both the coupling nut and receptacle eliminates cross coupling. The connector quickly mates and self locks in a 360° turn of the coupling nut.

Elongated mounting holes permit the Tri-Start Connector to intermount with various existing MIL-Spec box or wall mount receptacles, giving it a design replacement advantage.

Shells of stainless steel, or cadmium over nickel plating prevent severe corrosion. Resistance is tested through exposure to a 500 hour salt spray. Composite versions provide protection from salt spray exposure for 2000 hours. Other finish options are available; see how to order Tri-Start metal and Tri-Start Composite.

Recessed pins minimize potential contact damage in this 100% scoop-proof connector. In a blind mating application, mating shells cannot “scoop” the pins and cause a shorting or bending of contacts.

The design of the Amphenol Tri-Start interfacial seal meets the MIL-DTL-38999 Series III requirements for electrolytic erosion resistance.

A rigid dielectric insert with excellent electrical characteristics provides durable protection to the contacts. The socket contacts are probe proof, and all contacts are rear removable. They are plated in the standard 50 micro inches minimum gold, with 100 micro inches as an option, and are available in standard Tri-Start insert arrangements and special Pyle® insert arrangements in sizes 10 power, 12, 16, 20 and 22D contacts. Special insert patterns are also available with larger contacts in sizes 4 and 0.

III  
38999  
II  
I  
SJT

26482  
Matrix 2

83723 III  
Matrix  
Pyle

5015  
Crimp Rear  
Release Matrix

26500 Pyle

Printed  
Circuit Board

EMI Filter  
Transient

Fiber Optics

High Speed  
Contacts

Options  
Others



Depending on the shell style, shell size and contact count, weight savings can range from 17% to 40% compared to standard aluminum product

**Tri-Start Weight in Ounces (includes contacts)**

# Weight

|       | Wall Mount Receptacle (00 • Military D38999/20) |        |          |        |           |        | Jam Nut Receptacle (07) • Military D38999/24 |        |          |        |           |        | Plug (06) • Military D38999/26 |        |          |        |           |        |
|-------|---|--------|----------|--------|-----------|--------|--|--------|----------|--------|-----------|--------|--------------------------------|--------|----------|--------|-----------|--------|
|       | Stainless Steel                                 |        | Aluminum |        | Composite |        | Stainless Steel                              |        | Aluminum |        | Composite |        | Stainless Steel                |        | Aluminum |        | Composite |        |
|       | Pin   | Socket | Pin      | Socket | Pin       | Socket | Pin  | Socket | Pin      | Socket | Pin       | Socket | Pin                            | Socket | Pin      | Socket | Pin       | Socket |
| 9-35  | .7216   | .7840  | .3248    | .3777  | .2588     | .3121  | 1.1472                                       | 1.2096 | .4416    | .5040  | .3489     | .4413  | 1.0736                         | 1.1360 | .4236    | .4625  | .2606     | .2994  |
| 9-98  | .7216   | .7776  | .2496    | .3056  | .1664     | .2224  | 1.1472                                       | 1.2032 | .4416    | .4976  | .3744     | .4640  | 1.0736                         | 1.1296 | .3968    | .4624  | .2991     | .2337  |
| 11-35 | .9488   | 1.0800 | .3632    | .4960  | .2753     | .4081  | 1.4304                                       | 1.5632 | .5936    | .7264  | .4679     | .6007  | 1.2480                         | 1.3808 | .5312    | .6389  | .3450     | .4582  |
| 11-98 | .9488   | 1.0620 | .3632    | .4768  | .2753     | .3889  | 1.4304                                       | 1.5440 | .5936    | .7072  | .4679     | .5815  | 1.2480                         | 1.3616 | .5330    | .6283  | .3468     | .4457  |
| 13-8  | 1.2096  | 1.3888 | .4800    | .6592  | .3696     | .5488  | 1.9104                                       | 2.0896 | .7664    | .9456  | .6560     | .8352  | 1.8048                         | 1.9840 | .7936    | .9728  | .5237     | .5952  |
| 13-35 | 1.2160  | 1.4320 | .4864    | .7024  | .3762     | .5922  | 1.9168                                       | 2.1328 | .7728    | .9888  | .6136     | .8296  | 1.8112                         | 2.0272 | .8000    | .8472  | .5301     | .6531  |
| 13-98 | 1.2160  | 1.4016 | .4864    | .6720  | .3762     | .5618  | 1.9168                                       | 2.1024 | .7728    | .9584  | .6136     | .7992  | 1.8112                         | 1.9968 | .7978    | .9856  | .5244     | .7157  |
| 15-5  | 1.5312  | 1.7904 | .6352    | .8944  | .5027     | .7619  | 2.3792                                       | 2.6384 | .9728    | 1.2320 | .7749     | 1.0341 | 2.2704                         | 2.5456 | .9632    | 1.1719 | .6450     | .8467  |
| 15-18 | 1.5456  | 1.8416 | .7760    | .9456  | .6432     | .8128  | 2.3936                                       | 2.6896 | .9872    | 1.2832 | .8544     | 1.1504 | 2.2848                         | 2.5808 | .9776    | 1.2736 | .6594     | .8208  |
| 15-35 | 1.5424  | 1.8768 | .6464    | .9808  | .5139     | .8483  | 2.3904                                       | 2.7344 | .9840    | 1.3280 | .7861     | 1.1301 | 2.2816                         | 2.6256 | 1.2179   | 1.3184 | .8961     | 1.0002 |
| 17-6  | 2.1488  | 2.5904 | .9360    | 1.3776 | .7812     | 1.2228 | 2.9152                                       | 3.3568 | 1.2336   | 1.6752 | .9940     | 1.4356 | 2.5008                         | 3.1024 | 1.1408   | 1.7424 | .8160     | 1.4176 |
| 17-26 | 2.1344  | 2.5600 | .9216    | 1.3472 | .7668     | 1.1924 | 2.9008                                       | 3.3264 | 1.2192   | 1.6448 | .9796     | 1.4052 | 2.4864                         | 2.9120 | 1.1264   | 1.3343 | .8017     | .8062  |
| 17-35 | 2.1360  | 2.6640 | .9232    | 1.4512 | .7684     | 1.2964 | 2.9024                                       | 3.4304 | 1.2208   | 1.7488 | .9812     | 1.5092 | 2.4880                         | 3.0160 | 1.1280   | 1.5497 | .8033     | 1.2144 |
| 19-11 | 2.2592  | 2.6656 | .9696    | 1.4528 | .7925     | 1.2757 | 3.4352                                       | 3.9184 | 1.4720   | 1.9552 | 1.2033    | 1.6865 | 2.9808                         | 3.4640 | 1.3472   | 1.8304 | .9632     | 1.4464 |
| 19-32 | 2.1888  | 2.7264 | .9760    | 1.5136 | .7989     | 1.3365 | 3.4416                                       | 3.9792 | 1.4784   | 2.0160 | 1.2097    | 1.7473 | 2.9872                         | 3.5248 | 1.3536   | 1.8912 | .9696     | 1.5072 |
| 19-35 | 2.1920  | 2.8432 | .9792    | 1.6304 | .8021     | 1.4533 | 3.4448                                       | 4.0960 | 1.4816   | 2.1328 | 1.2129    | 1.8641 | 2.9904                         | 3.6416 | 1.3568   | 2.0080 | .9728     | 1.6240 |
| 21-11 | 2.7456  | 3.4640 | 1.3088   | 2.0272 | 1.1088    | 1.8272 | 3.9712                                       | 4.6896 | 1.8128   | 2.5312 | 1.6128    | 2.3312 | 3.4448                         | 4.1632 | 1.7344   | 2.5312 | 1.3039    | 1.8710 |
| 21-16 | 2.6784  | 3.3168 | 1.2416   | 1.8800 | 1.0422    | 1.6806 | 3.9040                                       | 4.5424 | 1.7456   | 2.3840 | 1.4505    | 2.0889 | 3.3776                         | 4.0160 | 1.6672   | 2.3168 | 1.2352    | 1.8736 |
| 21-35 | 2.6672  | 3.4992 | 1.2304   | 2.0624 | 1.0310    | 1.8630 | 3.8928                                       | 4.7248 | 1.7344   | 2.5664 | 1.4393    | 2.2713 | 3.3664                         | 4.1984 | 1.6560   | 2.2309 | 1.2255    | 1.8003 |
| 21-41 | 2.6768  | 3.3600 | 1.2400   | 1.9232 | 1.0406    | 1.7238 | 3.9024                                       | 4.5856 | 1.7440   | 2.4272 | 1.4489    | 2.1321 | 3.3760                         | 3.5792 | 1.6656   | 1.8688 | 1.2336    | 1.4368 |
| 23-21 | 3.0352  | 3.8624 | 1.4496   | 2.2768 | 1.2279    | 2.0551 | 4.2368                                       | 5.0640 | 1.9440   | 2.7712 | 1.6368    | 2.4640 | 3.7920                         | 4.6192 | 1.9216   | 2.7488 | 1.4637    | 2.2896 |
| 23-35 | 3.0240  | 4.0448 | 1.4384   | 2.4592 | 1.2167    | 2.2375 | 4.2256                                       | 5.2464 | 1.9328   | 2.9536 | 1.6256    | 2.6464 | 3.7808                         | 4.8016 | 1.9104   | 2.6087 | 1.4525    | 2.1507 |
| 23-53 | 2.8992  | 3.9072 | 1.4560   | 2.4816 | 1.2343    | 2.2599 | 4.2432                                       | 5.1088 | 1.9504   | 2.8160 | 1.6432    | 2.5088 | 3.7984                         | 4.6640 | 1.9280   | 2.7936 | 1.4672    | 2.2384 |
| 25-4  | 3.4512  | 4.4800 | 1.7312   | 2.8816 | 1.4864    | 2.1904 | 4.8048                                       | 5.8272 | 2.2016   | 3.2480 | 1.9568    | 2.8720 | 4.2224                         | 5.2496 | 2.2128   | 3.2560 | 1.7133    | 2.4163 |
| 25-19 | 3.5312  | 4.7264 | 1.8112   | 3.0064 | 1.5664    | 2.7616 | 4.8848                                       | 6.0816 | 2.2816   | 3.4784 | 2.0368    | 3.2336 | 4.3024                         | 5.4992 | 2.2928   | 3.4896 | 1.7933    | 2.7058 |
| 25-20 | 3.8190  | 4.7150 | 2.0173   | 3.1125 | 1.7733    | 2.8512 | 5.1430                                       | 6.0380 | 2.4877   | 3.5421 | 2.1872    | 3.2416 | 4.4350                         | 5.3300 | 2.2580   | 3.0182 | 1.8288    | 2.8928 |
| 25-35 | 3.4416  | 4.6656 | 1.7216   | 2.9456 | 1.4776    | 2.7016 | 4.7952                                       | 6.0192 | 2.1920   | 3.4160 | 1.8915    | 3.1155 | 4.2128                         | 5.4368 | 2.2032   | 3.4272 | 1.7037    | 2.9277 |
| 25-61 | 3.4304  | 4.4848 | 1.7282   | 2.7648 | 1.4841    | 2.5208 | 4.7840                                       | 5.8384 | 2.1808   | 3.2352 | 1.8803    | 2.9347 | 4.2016                         | 5.2560 | 2.1920   | 3.2464 | 1.6912    | 2.7456 |

All weight measurements are for reference only.

- 38999 III
- SJT I II
- 26482 Matrix 2
- 83723 III Pyle Matrix
- 5015 Crimp Rear Release Matrix
- 26500 Pyle
- Printed Circuit Board
- EMI Filter Transient
- Fiber Optics
- High Speed Contacts
- Options Others

### TRI-START, SERIES III TYPICAL SHIELDING EFFECTIVENESS TEST DATA

EMI/EMP SHIELDING EFFECTIVENESS dB  
TESTING BY TRIAXIAL METHOD



### TRI-START, SERIES III TYPICAL SHIELDING EFFECTIVENESS TEST DATA

EMI/EMP SHIELDING EFFECTIVENESS dB  
TESTING BY MODE STIRRING METHOD



Amphenol® Tri-Start connectors provide EMI/EMP shielding capability which exceeds MIL-DTL-38999 Series III requirements.

The TV and CTV Series III connector with standard solid metal to metal coupling, EMI grounding fingers and conductive finishes has proven to be the ultimate in EMI/EMP shielding effectiveness. The charts illustrate shielding effectiveness data which is typical of Tri-Start connectors tested with the nickel finish (Class F-metal, Class M-composite) over a wide frequency range.

The vibration capability of the Tri-Start Series is shown in the chart below. This illustrates the most severe vibration envelope of any qualified connector available today.

These capabilities along with a +200°C, -65°C temperature rating and superior moisture sealing protection provide the user with a connector that can withstand the most rigorous application.

### TRI-START VIBRATION CRITERIA

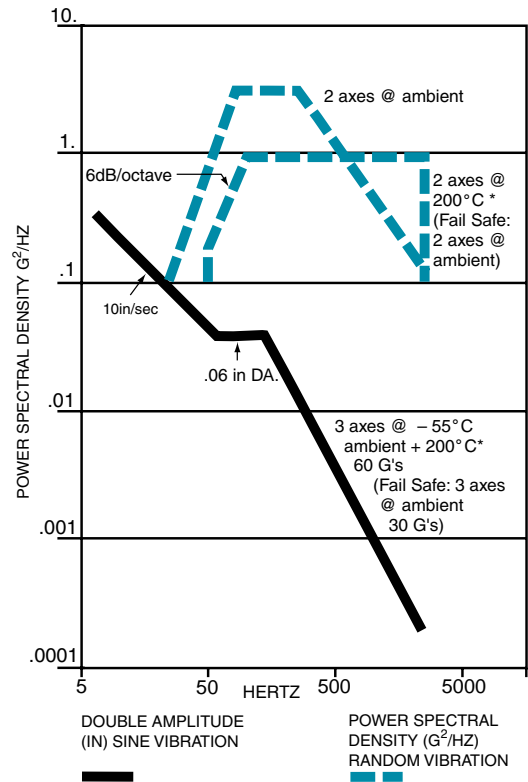

\* Dependant on shell finish

Test data beyond 2GHz is subject to equipment variation.

NOTE: For test data information on the new Clutch-Lok Tri-Start, high vibration connectors, consult Amphenol Aerospace.

III  
38999  
II  
I  
SJT

Matrix 2  
26482

Matrix Pyle  
83723 III

Release Matrix  
Crimp Rear  
5015

26500 Pyle

Printed  
Circuit Board

EMI Filter  
Transient

Fiber Optics

High Speed  
Contacts

Options  
Others

### Easy Steps to build a part number... Tri-Start Series III TV

| 1.         | 2.          | 3.            | 4.                             | 5.           | 6.                        | 7.                 |
|------------|-------------|---------------|--------------------------------|--------------|---------------------------|--------------------|
| Commercial | Shell Style | Service Class | Shell Size– Insert Arrangement | Contact Type | Alternate Keying Position | Special Variations |
| TVPS       | 00          | RF            | 9-35                           | P            | B                         | (XXX)              |
| Military   | Shell Style | Service Class | Shell Size– Insert Arrangement | Contact Type | Alternate Keying Position |                    |
| D38999/    | 20          | J             | G35                            | P            | N                         |                    |

Step 1. Select a Connector Type

Step 2. Select a Shell Style

|        | Designates   |
|--------|--|
| TV     | Tri-Start Series Connector   |
| TVP    | Back panel mounted receptacle  |
| TVS    | 200° C rated   |
| TVPS   | Panel mounted, 200°C rated receptacle  |
| MTV    | CLUTCH-LOK connector with "MS" stamping (Note: remove dashes in how to order part number when ordering CLUTCH-LOK) |
| CTV    | Composite MIL-DTL-38999 Series III Connector   |
| CTVP   | Panel mounted composite receptacle   |
| CTVS   | 200° C rated, composite  |
| CTVPS  | Composite Panel mounted, 200° rated receptacle   |
| D38999 | Military MIL-DTL-38999 Series III Connector  |

| COMMERCIAL             |         |     |      | MILITARY   |                 |                           | Designates |  |
|------------------------|---------|-----|------|------------|-----------------|---------------------------|------------|--|
| TVP, TVPS, CTVP, CTVPS | TV, CTV | TVS | CTVS | CLUTCH-LOK | D38999 Military | D38999 Military Composite |            | MTV, D38999 CLUTCH-LOK   |
| 00                     |         |     |      |            | 20              | 20                        |            | Wall Mount Receptacle  |
| 02                     |         |     |      |            |                 |                           |            | Box Mount Receptacle   |
|                        |         |     |      |            | 21              |                           |            | Box Mount Receptacle Hermetic  |
|                        | 01      | 01  | 01   |            |                 |                           |            | Line Receptacle  |
|                        | 06      | 06  | 06   |            | 26              | 26                        |            | Straight Plug  |
|                        | 07      | 07  | 07   |            | 24              | 24                        |            | Jam Nut Receptacle   |
|                        | 09      | 09  |      |            |                 |                           |            | Flange Mounted Plug  |
|                        |         |     |      |            | 23              |                           |            | Jam Nut Receptacle Hermetic  |
|                        |         | I   |      |            | 25              |                           |            | Solder Mount Receptacle Hermetic                                       |
|                        |         | HI  |      |            | 27              |                           |            | Weld Mounted Receptacle, (Hermetic) Only                               |
|                        |         |     |      | 26         |                 |                           | 26         | CLUTCH-LOK high vibration straight plug (service Classes RK & RS only) |
|                        |         |     |      |            | 29              |                           |            | Lanyard release plug with pin contacts                                 |
|                        |         |     |      |            | 30              |                           |            | Lanyard release plug with socket contacts                              |
|                        |         |     |      |            | 31              |                           |            | Lanyard release plug for MIL-STD-1760 with pin contacts                |
|                        |         |     |      |            | 32              |                           |            | Plug protection cap  |
|                        |         |     |      |            | 33              |                           |            | Receptacle protection cap  |



Wall Mount Receptacle



Line Receptacle



Box Mount Receptacle



Straight Plug

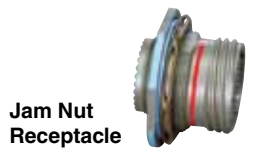

Jam Nut Receptacle



Flange Mounting Plug



Deep Reach Receptacle



Solder Mount Hermetic Receptacle



Lanyard Release Plug

- 38999 III
- SJT I II
- 26482 Matrix 2
- 83723 III Pyle Matrix
- 5015 Crimp Rear Release Matrix
- 26500 Pyle
- Printed Circuit Board
- EMI Filter Transient
- Fiber Optics
- High Speed Contacts
- Options Others

**Step 3. Select a Service Class**

|                |             |               |                         |              |                    |                    |
|----------------|-------------|---------------|-------------------------|--------------|--------------------|--------------------|
| 1.             | 2.          | 3.            | 4.                      | 5.           | 6.                 | 7.                 |
| Connector Type | Shell Style | Service Class | Shell Size-Insert Arrg. | Contact Type | Alternate Position | Special Variations |
|                |             | RX            |                         |              |                    |                    |

| TV, TVP   | CTV, CTVP     | CTVS, CTVPS   | TVS       | TVPS     | CLUTCH-LOK | Military               | Finish                          | Description  |
|-----------|---------------|---------------|-----------|----------|------------|------------------------|---------------------------------|--|
|           |               |               | RX        |          |            | C                      | Anodic Coating                  | Alternate finish, Non-conductive, anodic coated aluminum, 500 hour salt spray, 200°C. Consult Amphenol, Sidney NY for details, options and availability of non-cadmium or nickel finishes. |
|           |               | RF-Composite  | RF-Metal  | RF-Metal |            | F-Metal<br>M-Composite | Electroless Nickel              | electroless nickel plated aluminum (composite) optimum EMI shielding effectiveness-65dB @ 10GHz specification min., 48 hour salt spray, 200°C (Composite-2000 hours dynamic salt spray).   |
|           |               | RGF-Composite | RGF-Metal |          |            |                        | Electroless Nickel              | electroless nickel plated ground plane aluminum (composite), 200°C   |
|           |               |               |           |          |            | G                      | Electroless Nickel              | Space grade, electroless nickel, 48 hour salt spray, 200°C   |
| RGW-Metal | RGW-Composite |               |           |          |            |                        | Olive Drab Cadmium              | Olive drab cadmium plated ground plane aluminum (composite), 175°C   |
|           |               |               | RK**      | RK**     | RK**       | K                      | Passivated Stainless Steel      | Corrosion resistant stainless steel, firewall capability, plus 500 hour salt spray resistance, EMI -45 dB @ 10 GHz specification min., 200°C   |
|           |               |               | RL        | RL       |            | L                      | Stainless Steel w/ Nickel Plate | Corrosion resistant steel, electro deposited nickel, 500 hour salt spray, 200°C, non firewall  |
| RW-Metal  | RW-Composite  |               |           |          |            | W-Metal<br>J-Composite | Olive Drab Cadmium              | Corrosion resistant olive drab cadmium plate aluminum (composite), 500 hour salt spray, EMI -50 dB @ 10 GHz specification min., 175°C (Composite-2000 hours dynamic salt spray).           |
|           |               |               | Y         | Y        |            | Y                      | Stainless Steel                 | Hermetic seal, passivated stainless steel, 200°C   |
|           |               |               | RS*       | RS*      | RS*        | S                      | Stainless Steel w/ Nickel Plate | (Non-hermetic connectors), Nickel plated, corrosion resistant steel, firewall capability, 500 hour salt spray, 200°  |
|           |               |               | YN        | YN       |            | N                      | Stainless Steel w/ Nickel Plate | (Hermetic connectors), Nickel plated corrosion resistant steel, 200°C  |
| DT        |               |               |           |          |            | T                      | Durmalon plated                 | Nickel-PTFE alternative to Cadmium. Corrosion resistant, 500 hour salt spray, EMI-50dB at 10GHz specification min., 175°C  |
| DZ        |               |               |           |          |            | Z                      | Zinc-Nickel Plated              | Zinc-Nickel Alternative to Cadmium corrosion resistant, 500 hour salt spray, Conductive, -65°C to +175°C   |

**Quadrax or Differential Twinax:**

The incorporation of Quadrax or Differential Twinax contacts requires a modified connector to accommodate keyed contacts.  
 \* D38999/26KJ20PN, is a series III stainless steel plug with twin axial and coaxial contacts that may not meet the firewall requirement of the specification.  
 D38999/26KJ61HN, is a series III stainless steel plug with high durability contacts. However, the connector will be limited to 500 cycles of durability.  
 Insert arrangements using multi-axial (i.e. coax, twinax, triax shielded) contacts should not be used in firewall applications.

**Step 4. Select a Shell Size & Insert**  
 Arrangement see pg. 4-7

Shell Size & Insert Arrangement are on pages 4-7. First number represents Shell Size, second number is the Insert Arrangement.

|                |             |               |                         |              |                    |                    |
|----------------|-------------|---------------|-------------------------|--------------|--------------------|--------------------|
| 1.             | 2.          | 3.            | 4.                      | 5.           | 6.                 | 7.                 |
| Connector Type | Shell Style | Service Class | Shell Size-Insert Arrg. | Contact Type | Alternate Position | Special Variations |
|                |             |               | 22-2                    | P            |                    |                    |

**Step 5. Select a Contact Type**

| Designates |  |
|------------|--|
| <b>P</b>   | Pin Contacts   |
| <b>S</b>   | Socket Contacts  |
| <b>H</b>   | 1500 Cycle Pin Contacts - Recommended for composite  |
| <b>J</b>   | 1500 Cycle Socket Contacts - Recommended for composite   |
| <b>A</b>   | Same as "P" except supplied less pin Contacts (For Military D38999 prefix only)  |
| <b>B</b>   | Same as "S" except supplied less socket contacts ( A & B designate nonstandard contact applications) (For Military D38999 prefix only) |
| <b>X</b>   | Eyelet contacts, hermetics only  |

- III 38999
- II
- I
- SJT
- Matrix 2 26482
- Matrix Pyle 83723 III
- Release Matrix 5015
- 26500 Pyle
- Circuit Board Printed
- Transient EMI Filter
- Fiber Optics
- High Speed Contacts
- Options Others

38999 III  
SJT I II

26482 Matrix 2

83723 III Pyle Matrix

5015 Crimp Rear Release Matrix

26500 Pyle

Printed Circuit Board

EMI Filter Transient

Fiber Optics

High Speed Contacts

Options Others

**Step 6. Select an Alternate Keying Position**

**Key/Keyway Position**

| Shell Size      | Key & Keyway Arrangement Identification Letter | AR° or AP° BSC | BR° or BP° BSC | CR° or CP° BSC | DR° or DP° BSC |
|-----------------|--|----------------|----------------|----------------|----------------|
| 9               | N*   | 105            | 140            | 215            | 265            |
|                 | A  | 102            | 132            | 248            | 320            |
|                 | B  | 80             | 118            | 230            | 312            |
|                 | C  | 35             | 140            | 205            | 275            |
|                 | D  | 64             | 155            | 234            | 304            |
| 11, 13, and 15  | N*   | 95             | 141            | 208            | 236            |
|                 | A  | 113            | 156            | 182            | 292            |
|                 | B  | 90             | 145            | 195            | 252            |
|                 | C  | 53             | 156            | 220            | 255            |
|                 | D  | 119            | 146            | 176            | 298            |
| 17 and 19       | N*   | 51             | 141            | 184            | 242            |
|                 | A  | 80             | 142            | 196            | 293            |
|                 | B  | 135            | 170            | 200            | 310            |
|                 | C  | 49             | 169            | 200            | 244            |
|                 | D  | 66             | 140            | 200            | 257            |
| 21, 23, and 25  | N*   | 62             | 145            | 180            | 280            |
|                 | A  | 79             | 153            | 197            | 272            |
|                 | B  | 80             | 142            | 196            | 293            |
|                 | C  | 135            | 170            | 200            | 310            |
|                 | D  | 49             | 169            | 200            | 244            |
| 25L, 33, and 37 | N*   | 66             | 140            | 188            | 257            |
|                 | A  | 62             | 145            | 188            | 280            |
|                 | B  | 79             | 153            | 197            | 272            |
|                 | C  | 80             | 142            | 188            | 293            |
|                 | D  | 135            | 170            | 188            | 310            |
|                 | N*   | 49             | 169            | 188            | 244            |
|                 | A  | 66             | 140            | 188            | 257            |
|                 | B  | 62             | 145            | 188            | 280            |
|                 | C  | 79             | 153            | 197            | 272            |
|                 | D  | 80             | 142            | 188            | 293            |

| 1.             | 2.          | 3.            | 4.                      | 5.           | 6.                 | 7.                 |
|----------------|-------------|---------------|-------------------------|--------------|--------------------|--------------------|
| Connector Type | Shell Style | Service Class | Shell Size-Insert Arrg. | Contact Type | Alternate Position | Special Variations |
|                |             |               |                         |              | B                  |                    |

A plug with a given rotation letter will mate with a receptacle with the same rotation letter. The angles for a given connector are the same whether it contains pins or sockets. Master key stay fixed, minor keys rotate. Inserts are not rotated in conjunction with the master key/keyway.

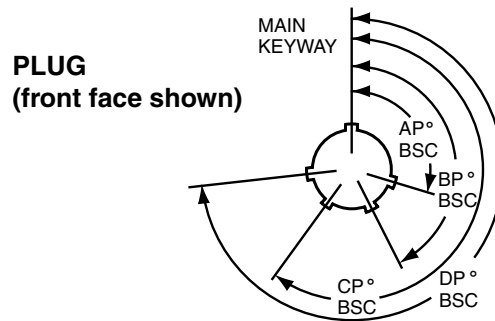
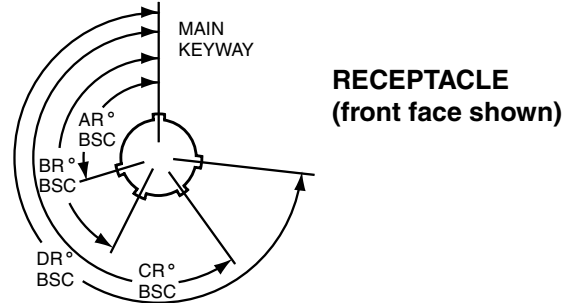

\* An "N" designation is used on D38999 military part number but not on the commercial versions

**Step 7. Special Variations**

Consult Amphenol Aerospace, Sidney NY for variations.

| 1.             | 2.          | 3.            | 4.                      | 5.           | 6.                 | 7.                 |
|----------------|-------------|---------------|-------------------------|--------------|--------------------|--------------------|
| Connector Type | Shell Style | Service Class | Shell Size-Insert Arrg. | Contact Type | Alternate Position | Special Variations |
|                |             |               |                         |              |                    | (xxx)              |



### Easy Steps to build a part number... Boeing BACC63 CT & CU

1. 2. 3. 4. 5. 6. 7. 8.

| Boeing Basic Number | Style | Shell Size | Shell Finish & Contact | Insert Arrangement | Contact Type | Alternate Keying Position | Ordering Option |
|---------------------|-------|------------|------------------------|--------------------|--------------|---------------------------|-----------------|
| BACC63              | CT    | 15         | —                      | 19                 | P            | N                         | H               |

## Composite

**Step 1. Boeing Number BACC63**

**Step 2. Select a Style**

|    | Designates           |
|----|----------------------|
| CT | Composite Plug       |
| CU | Composite Receptacle |

**Step 3. Shell Size 15**

|    | Designates     |
|----|----------------|
| 15 | One Shell Size |

**Step 4. Select a Shell Finish & Contact**

|   | Designates                              |
|---|---|
| C | CT Style Only. Cadmium Plated, Grounded |
| D | Cadmium Plated, ungrounded              |
| G | Nickel Plated, Grounded                 |
| — | Nickel Plated, Ungrounded               |

**Step 5. Insert Arrangements-**  
Consult Amphenol Aerospace for insert Arrangements available.

**Step 6. Select a Contact Type**

|   | Designates |
|---|------------|
| P | Pin        |
| S | Socket     |

**Step 7. Select an Alternate Keying Position**

|     | Designates |
|-----|------------|
| N   | Normal     |
| A-E | Alternates |

**Step 8. Ordering Option**

|       | Designates                    |
|-------|-------------------------------|
| H     | Without Contacts & Seal Plugs |
| Blank | With contacts and seal plugs  |

### Easy Steps to build a part number... Boeing BACC63 DB & DC

1. 2. 3. 4. 5. 6. 7. 8.

| Boeing Basic Number | Style | Shell Size | Separator | Insert Arrangement | Contact Type | Alternate Keying Position | Ordering Option |
|---------------------|-------|------------|-----------|--------------------|--------------|---------------------------|-----------------|
| BACC63              | DB    | 15         | —         | 19                 | P            | N                         | H               |
| BACC63              | DC    | 17         | —         | 8                  | P            | N                         | H               |

## Stainless Steel

**Step 1. Boeing Number BACC63**

**Step 2. Select a Style**

|    | Designates                 |
|----|----------------------------|
| DB | Stainless Steel Plug       |
| DC | Stainless Steel Receptacle |

**Step 3. Select a Shell Size**

|      | Designates |
|------|------------|
| 9-25 | Shell Size |

**Step 4. Separator**

|   | Designates |
|---|------------|
| — | Separator  |

**Step 5. Insert Arrangements-**  
Consult Amphenol Aerospace for insert Arrangements available.

**Step 7. Select an Alternate Keying Position**

|     | Designates |
|-----|------------|
| N   | Normal     |
| A-E | Alternates |

**Step 8. Ordering Option**

|       | Designates                    |
|-------|-------------------------------|
| H     | Without Contacts & Seal Plugs |
| Blank | With contacts and seal plugs  |

**Step 6. Select a Contact Type**

|   | Designates |
|---|------------|
| P | Pin        |
| S | Socket     |

- III 38999
- II
- I
- SJT
- 26482 Matrix 2
- 83723 III Matrix Pyle
- 5015 Crimp Rear Release Matrix
- 26500 Pyle
- Printed Circuit Board
- EMI Filter Transient
- Fiber Optics
- High Speed Contacts
- Options Others

### Wall Mounting Receptacle

38999

SJT

26482

Matrix 2

83723 III

Matrix Pyle

5015

Crimp Rear Release Matrix

26500 Pyle

Printed Circuit Board

EMI Filter Transient

Fiber Optics

High Speed Contacts

Options Others

#### PART #

To complete, see how to order pages 22-24.

Connector Type Shell Style Service Class Shell Size & Insert Arrg Contact Type Alternate Position Special Variations

|         |    |    |      |   |   |       |
|---------|----|----|------|---|---|-------|
| TVP     | 00 | RW | 9-35 | P | B | (453) |
| TVPS    | 00 | RK | X-X  | X | X | (XXX) |
| TVPS    | 00 | RF | X-X  | X | X | (XXX) |
| TVPS    | 00 | RS | X-X  | X | X | (XXX) |
| CTVP    | 00 | RW | X-X  | X | X | (XXX) |
| CTVPS   | 00 | RF | X-X  | X | X | (XXX) |
| D38999/ | 20 | X  | X-X  | X | X | NA    |

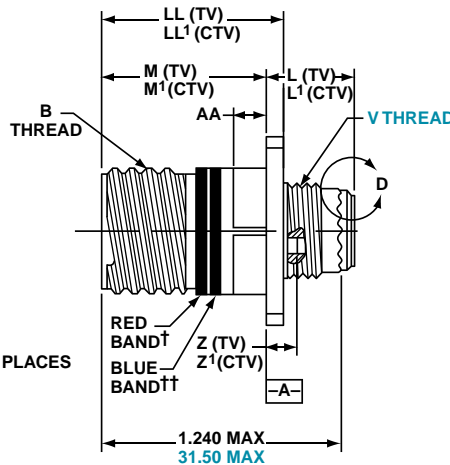
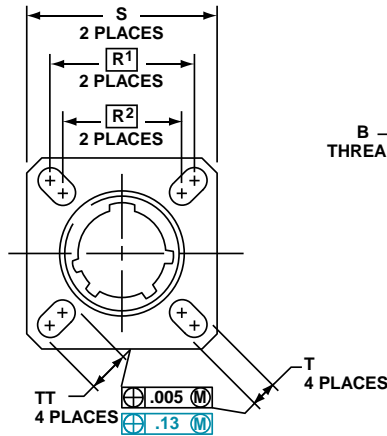

VIEW D FOR SIZE 8 COAXIAL ONLY, RELATIVE TO -A-

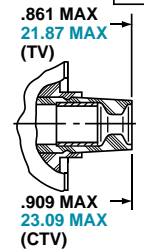

PANEL HOLE DIMENSIONS

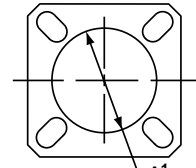

BACK PANEL MOUNTING

VIEW D FOR SIZE 8 TWINAX ONLY, RELATIVE TO -A-

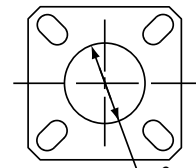
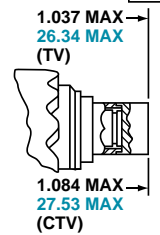

FRONT PANEL MOUNTING

† Red band indicates fully mated

†† Blue band indicates rear release contact retention system

Inches

| Shell Size | MS Shell Size Code | B Thread Class 2A 0.1P=0.3L-TS (Plated) | L Max. (TV) | L' Max. (CTV) | M +.000 - .005 (TV) | M' +.000 - .005 (CTV) | R <sup>1</sup> | R <sup>2</sup> | S Max. | T ±.008 | Z Max. (TV) | Z' Max. (CTV) | A <sup>1</sup> Back Panel Mount | A <sup>2</sup> Front Panel Mount | AA Max. Panel Thickness | LL +.006 - .000 (TV) | LL1 ±.005 (CTV) | TT ±.008 |
|------------|--------------------|---|-------------|---------------|---------------------|-----------------------|----------------|----------------|--------|---------|-------------|---------------|---------------------------------|----------------------------------|-------------------------|----------------------|-----------------|----------|
| 9          | A                  | .6250                                   | .469        | .514          | .820                | .773                  | .719           | .594           | .948   | .128    | .153        | .198          | .650                            | .510                             | .234                    | .905                 | .908            | .216     |
| 11         | B                  | .7500                                   | .469        | .514          | .820                | .773                  | .812           | .719           | 1.043  | .128    | .153        | .198          | .800                            | .620                             | .234                    | .905                 | .908            | .194     |
| 13         | C                  | .8750                                   | .469        | .514          | .820                | .773                  | .906           | .812           | 1.137  | .128    | .153        | .198          | .910                            | .740                             | .234                    | .905                 | .908            | .194     |
| 15         | D                  | 1.0000                                  | .469        | .514          | .820                | .773                  | .969           | .906           | 1.232  | .128    | .153        | .198          | 1.040                           | .900                             | .234                    | .905                 | .908            | .173     |
| 17         | E                  | 1.1875                                  | .469        | .514          | .820                | .773                  | 1.062          | .969           | 1.323  | .128    | .153        | .198          | 1.210                           | 1.010                            | .234                    | .905                 | .908            | .194     |
| 19         | F                  | 1.2500                                  | .469        | .514          | .820                | .773                  | 1.156          | 1.062          | 1.449  | .128    | .153        | .198          | 1.280                           | 1.130                            | .234                    | .905                 | .908            | .194     |
| 21         | G                  | 1.3750                                  | .500        | .545          | .790                | .741                  | 1.250          | 1.156          | 1.575  | .128    | .183        | .228          | 1.410                           | 1.250                            | .204                    | .905                 | .904            | .194     |
| 23         | H                  | 1.5000                                  | .500        | .545          | .790                | .741                  | 1.375          | 1.250          | 1.701  | .154    | .183        | .228          | 1.530                           | 1.360                            | .204                    | .905                 | .904            | .242     |
| 25         | J                  | 1.6250                                  | .500        | .545          | .790                | .741                  | 1.500          | 1.375          | 1.823  | .154    | .183        | .228          | 1.660                           | 1.470                            | .204                    | .905                 | .904            | .242     |

Millimeters

| Shell Size | MS Shell Size Code | L Max. (TV) | L' Max. (CTV) | M +.00 - .13 (TV) | M' +.00 - .13 (CTV) | R <sup>1</sup> | R <sup>2</sup> | S Max. | T ±.20 | V Thread Metric | Z Max. (TV) | Z' Max. (CTV) | A <sup>1</sup> Back Panel Mount | A <sup>2</sup> Front Panel Mount | AA Max. | LL +.15 - .00 (TV) | LL1 ±.13 (CTV) | TT ±.20 |
|------------|--------------------|-------------|---------------|-------------------|---------------------|----------------|----------------|--------|--------|-----------------|-------------|---------------|---------------------------------|----------------------------------|---------|--------------------|----------------|---------|
| 9          | A                  | 11.91       | 13.06         | 20.83             | 19.63               | 18.26          | 15.09          | 24.1   | 3.25   | M12X1-6g        | 3.89        | 5.03          | 16.66                           | 13.11                            | 5.94    | 22.99              | 23.06          | 5.49    |
| 11         | B                  | 11.91       | 13.06         | 20.83             | 19.63               | 20.62          | 18.26          | 26.5   | 3.25   | M15X1-6g        | 3.89        | 5.03          | 20.22                           | 15.88                            | 5.94    | 22.99              | 23.06          | 4.93    |
| 13         | C                  | 11.91       | 13.06         | 20.83             | 19.63               | 23.01          | 20.62          | 28.9   | 3.25   | M18X1-6g        | 3.89        | 5.03          | 23.42                           | 19.05                            | 5.94    | 22.99              | 23.06          | 4.93    |
| 15         | D                  | 11.91       | 13.06         | 20.83             | 19.63               | 24.61          | 23.01          | 31.3   | 3.25   | M22X1-6g        | 3.89        | 5.03          | 26.59                           | 23.01                            | 5.94    | 22.99              | 23.06          | 4.39    |
| 17         | E                  | 11.91       | 13.06         | 20.83             | 19.63               | 26.97          | 24.61          | 33.7   | 3.25   | M25X1-6g        | 3.89        | 5.03          | 30.96                           | 25.81                            | 5.94    | 22.99              | 23.06          | 4.93    |
| 19         | F                  | 11.91       | 13.06         | 20.83             | 19.63               | 29.36          | 26.97          | 36.9   | 3.25   | M28X1-6g        | 3.89        | 5.03          | 32.94                           | 28.98                            | 5.94    | 22.99              | 23.06          | 4.93    |
| 21         | G                  | 12.70       | 13.84         | 20.07             | 18.82               | 31.75          | 29.36          | 40.1   | 3.25   | M31X1-6g        | 4.65        | 5.79          | 36.12                           | 32.16                            | 5.18    | 22.99              | 22.96          | 4.93    |
| 23         | H                  | 12.70       | 13.84         | 20.07             | 18.82               | 34.93          | 31.75          | 43.3   | 3.91   | M34X1-6g        | 4.65        | 5.79          | 39.29                           | 34.93                            | 5.18    | 22.99              | 22.96          | 6.15    |
| 25         | J                  | 12.70       | 13.84         | 20.07             | 18.82               | 38.10          | 34.93          | 46.4   | 3.91   | M37X1-6g        | 4.65        | 5.79          | 42.47                           | 37.69                            | 5.18    | 22.99              | 22.96          | 6.15    |

All dimensions for reference only

□ Designates true position dimensioning

# TVP02R – Crimp, Metal CTVP02R – Crimp, Composite

## Box Mounting Receptacle

### PART #

To complete, see how to order pages 22-24.

| Connector Type | Shell Style | Service Class | Shell Size & Insert Arrg | Contact Type | Alternate Position | Special Variations |
|----------------|-------------|---------------|--------------------------|--------------|--------------------|--------------------|
| TVP            | 02          | RW            | 9-35                     | P            | B                  | (453)              |
| TVPS           | 02          | RK            | X-X                      | X            | X                  | (XXX)              |
| TVPS           | 02          | RF            | X-X                      | X            | X                  | (XXX)              |
| TVPS           | 02          | RS            | X-X                      | X            | X                  | (XXX)              |
| CTVP           | 02          | RW            | X-X                      | X            | X                  | (XXX)              |
| CTVPS          | 02          | RF            | X-X                      | X            | X                  | (XXX)              |

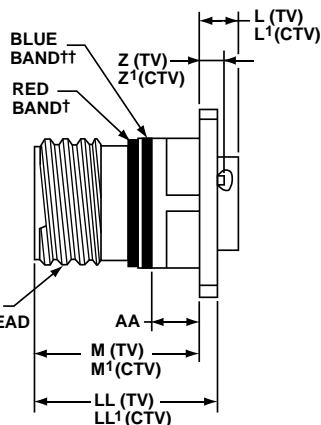
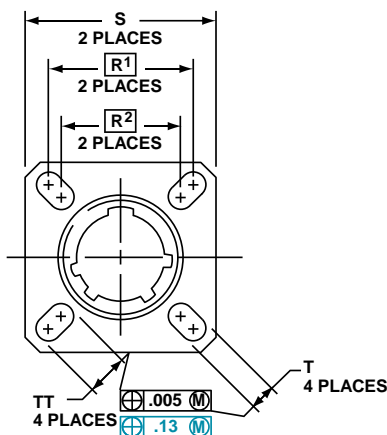

### PANEL HOLE DIMENSIONS

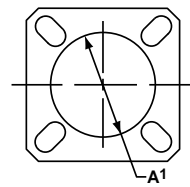

### BACK PANEL MOUNTING

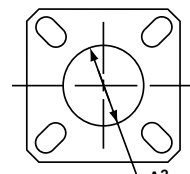

### FRONT PANEL MOUNTING

† Red band indicates fully mated

†† Blue band indicates rear release contact retention system

Consult Amphenol Aerospace for availability of composite box mount receptacles.

| Shell Size | MS Shell Size Code | B Thread Class 2A 0.1P=0.3L-TS (Plated) | L Max. (TV) | L' Max. (CTV) | M +.000 - .005 (TV) | M' +.000 - .005 (CTV) | R <sup>1</sup> | R <sup>2</sup> | S Max. | T ±.008 | Z Max. (TV) | Z' Max. (CTV) | A <sup>1</sup> Back Panel Mount | A <sup>2</sup> Front Panel Mount | AA Max. Panel Thickness | LL +.006 - .000 (TV) | LL1 ±.005 (CTV) | TT ±.008 |
|------------|--------------------|---|-------------|---------------|---------------------|-----------------------|----------------|----------------|--------|---------|-------------|---------------|---------------------------------|----------------------------------|-------------------------|----------------------|-----------------|----------|
| 9          | A                  | .6250                                   | .205        | .250          | .820                | .773                  | .719           | .594           | .948   | .128    | .153        | .198          | .650                            | .510                             | .234                    | .905                 | .908            | .216     |
| 11         | B                  | .7500                                   | .205        | .250          | .820                | .773                  | .812           | .719           | 1.043  | .128    | .153        | .198          | .800                            | .620                             | .234                    | .905                 | .908            | .194     |
| 13         | C                  | .8750                                   | .205        | .250          | .820                | .773                  | .906           | .812           | 1.137  | .128    | .153        | .198          | .910                            | .740                             | .234                    | .905                 | .908            | .194     |
| 15         | D                  | 1.0000                                  | .205        | .250          | .820                | .773                  | .969           | .906           | 1.232  | .128    | .153        | .198          | 1.040                           | .900                             | .234                    | .905                 | .908            | .173     |
| 17         | E                  | 1.1875                                  | .205        | .250          | .820                | .773                  | 1.062          | .969           | 1.323  | .128    | .153        | .198          | 1.210                           | 1.010                            | .234                    | .905                 | .908            | .194     |
| 19         | F                  | 1.2500                                  | .205        | .250          | .820                | .773                  | 1.156          | 1.062          | 1.449  | .128    | .153        | .198          | 1.280                           | 1.130                            | .234                    | .905                 | .908            | .194     |
| 21         | G                  | 1.3750                                  | .235        | .280          | .790                | .741                  | 1.250          | 1.156          | 1.575  | .128    | .183        | .228          | 1.410                           | 1.250                            | .204                    | .905                 | .904            | .194     |
| 23         | H                  | 1.5000                                  | .235        | .280          | .790                | .741                  | 1.375          | 1.250          | 1.701  | .154    | .183        | .228          | 1.530                           | 1.360                            | .204                    | .905                 | .904            | .242     |
| 25         | J                  | 1.6250                                  | .235        | .280          | .790                | .741                  | 1.500          | 1.375          | 1.823  | .154    | .183        | .228          | 1.660                           | 1.470                            | .204                    | .905                 | .904            | .242     |

Inches

| Shell Size | MS Shell Size Code | L Max. (TV) | L' Max. (CTV) | M +.00 - .13 (TV) | M' +.00 - .13 (CTV) | R <sup>1</sup> | R <sup>2</sup> | S Max. | T ±.20 | Z Max. (TV) | Z' Max. (CTV) | A <sup>1</sup> Back Panel Mount | A <sup>2</sup> Front Panel Mount | AA Max. | LL +.15 - .00 (TV) | LL1 ±.13 (CTV) | TT ±.20 |
|------------|--------------------|-------------|---------------|-------------------|---------------------|----------------|----------------|--------|--------|-------------|---------------|---------------------------------|----------------------------------|---------|--------------------|----------------|---------|
| 9          | A                  | 5.21        | 6.35          | 20.83             | 19.63               | 18.26          | 15.09          | 24.1   | 3.25   | 3.89        | 5.03          | 16.66                           | 13.11                            | 5.94    | 22.99              | 23.06          | 5.49    |
| 11         | B                  | 5.21        | 6.35          | 20.83             | 19.63               | 20.62          | 18.26          | 26.5   | 3.25   | 3.89        | 5.03          | 20.22                           | 15.88                            | 5.94    | 22.99              | 23.06          | 4.93    |
| 13         | C                  | 5.21        | 6.35          | 20.83             | 19.63               | 23.01          | 20.62          | 28.9   | 3.25   | 3.89        | 5.03          | 23.42                           | 19.05                            | 5.94    | 22.99              | 23.06          | 4.93    |
| 15         | D                  | 5.21        | 6.35          | 20.83             | 19.63               | 24.61          | 23.01          | 31.3   | 3.25   | 3.89        | 5.03          | 26.59                           | 23.01                            | 5.94    | 22.99              | 23.06          | 4.39    |
| 17         | E                  | 5.21        | 6.35          | 20.83             | 19.63               | 26.97          | 24.61          | 33.7   | 3.25   | 3.89        | 5.03          | 30.96                           | 25.81                            | 5.94    | 22.99              | 23.06          | 4.93    |
| 19         | F                  | 5.21        | 6.35          | 20.83             | 19.63               | 29.36          | 26.97          | 36.9   | 3.25   | 3.89        | 5.03          | 32.94                           | 28.98                            | 5.94    | 22.99              | 23.06          | 4.93    |
| 21         | G                  | 5.97        | 7.11          | 20.07             | 18.82               | 31.75          | 29.36          | 40.1   | 3.25   | 4.65        | 5.79          | 36.12                           | 32.16                            | 5.18    | 22.99              | 22.96          | 4.93    |
| 23         | H                  | 5.97        | 7.11          | 20.07             | 18.82               | 34.92          | 31.75          | 43.3   | 3.91   | 4.65        | 5.79          | 39.29                           | 34.93                            | 5.18    | 22.99              | 22.96          | 6.15    |
| 25         | J                  | 5.97        | 7.11          | 20.07             | 18.82               | 38.10          | 34.92          | 46.4   | 3.91   | 4.65        | 5.79          | 42.47                           | 37.69                            | 5.18    | 22.99              | 22.96          | 6.15    |

Millimeters

All dimensions for reference only

Designates true position dimensioning

38999  
SJT

26482  
Matrix 2

83723 III  
Matrix Pyle

5015  
Crimp Rear Release Matrix

26500 Pyle

Printed  
Circuit Board

EMI Filter  
Transient

Fiber Optics

High Speed  
Contacts

Options  
Others

### Straight Plug

- 38999 III
- SJT I II
- 26482 Matrix 2
- 83723 III Pyle Matrix
- 5015 Crimp Rear Release Matrix
- 26500 Pyle
- Printed Circuit Board
- EMI Filter Transient
- Fiber Optics
- High Speed Contacts
- Options Others

#### PART #

To complete, see how to order pages 22-24.

| Connector Type | Shell Style | Service Class | Shell Size & Insert Arrg | Contact Type | Alternate Position | Special Variations |
|----------------|-------------|---------------|--------------------------|--------------|--------------------|--------------------|
| TV             | 06          | RW            | 9-35                     | P            | B                  | (453)              |
| TVS            | 06          | RK            | X-X                      | X            | X                  | (XXX)              |
| TVS            | 06          | RF            | X-X                      | X            | X                  | (XXX)              |
| TVS            | 06          | RS            | X-X                      | X            | X                  | (XXX)              |
| CTV            | 06          | RW            | X-X                      | X            | X                  | (XXX)              |
| CTVS           | 06          | RF            | X-X                      | X            | X                  | (XXX)              |
| D38999/        | 26          | X             | X-X                      | X            | X                  | NA                 |

#### METAL



VIEW D FOR SIZE 8 COAXIAL ONLY, RELATIVE TO -A-



#### COMPOSITE



VIEW D FOR SIZE 8 TWINAX ONLY, RELATIVE TO -A-



† Blue band indicates rear release contact retention system

Inches

| Shell Size | MS Shell Size Code | B Thread 0.1P-0.3L-TS-2B (Plated) | Q Dia. Max. |
|------------|--------------------|-----------------------------------|-------------|
| 9          | A                  | .6250                             | .858        |
| 11         | B                  | .7500                             | .984        |
| 13         | C                  | .8750                             | 1.157       |
| 15         | D                  | 1.0000                            | 1.280       |
| 17         | E                  | 1.1875                            | 1.406       |
| 19         | F                  | 1.2500                            | 1.516       |
| 21         | G                  | 1.3750                            | 1.642       |
| 23         | H                  | 1.5000                            | 1.768       |
| 25         | J                  | 1.6250                            | 1.890       |

Millimeters

| Shell Size | MS Shell Size Code | Q Max. | V Thread Metric |
|------------|--------------------|--------|-----------------|
| 9          | A                  | 21.8   | M12X1-6g        |
| 11         | B                  | 25.0   | M15X1-6g        |
| 13         | C                  | 29.4   | M18X1-6g        |
| 15         | D                  | 32.5   | M22X1-6g        |
| 17         | E                  | 35.7   | M25X1-6g        |
| 19         | F                  | 38.5   | M28X1-6g        |
| 21         | G                  | 41.7   | M31X1-6g        |
| 23         | H                  | 44.9   | M34X1-6g        |
| 25         | J                  | 48.0   | M37X1-6g        |

All dimensions for reference only.

# TV26/MTV26 – Crimp, Metal CLUTCH-LOK™ Plug

## For High Vibration Applications

### PART #

To complete, see how to order pages 22-24.

| Connector Type | Shell Style | Service Class | Shell Size & Insert Arrg | Contact Type | Alternate Position | Special Variations |
|----------------|-------------|---------------|--------------------------|--------------|--------------------|--------------------|
| TV             | 26          | RK            | 9-35                     | P            | N                  | (453)              |
| TV             | 26          | RS            | X-X                      | X            | N                  | (XXX)              |
| MTV            | 26          | RK            | X-X                      | X            | N                  | (XXX)              |
| MTV            | 26          | RS            | X-X                      | X            | N                  | (XXX)              |

For parts with MS Stamping use MTV26( ) part number as shown above.

Designed for high vibration and harsh environments such as aircraft gas turbine engines, the CLUTCH-LOK is also an ideal choice for demanding applications such as aircraft, space and military ground vehicles. The unique clutch design of the Amphenol CLUTCH-LOK means that you don't have to compromise the need for quick, smooth mating of plugs and receptacles in order to get increased uncoupling torque.

The CLUTCH-LOK has proven to not only remain mated and pass all the Series III specification requirements, it also has proven to actually tighten itself under vibration. This is a powerful advantage over the traditionally high vibration application connectors. The CLUTCH-LOK is also a tremendous advantage in inaccessible, hard to reach areas where mating torque is difficult to apply and complete coupling is not verifiable by inspection.

### CLUTCH-LOK features and benefits:

- High degree of differential torque
- Infinite free coupling and positive metal-to-metal bottoming with each mating
- No settling back to the next ratchet tooth
- Available with stainless steel shells and Class K firewall inserts
- All the advantages of MIL-DTL-38999 Series III including EMI/RFI shielding, electrolytic erosion resistance and contact protection with recessed pins
- Enhanced connector performance at affordable prices
- Completely intermateable with all existing MIL-DTL-38999 Series III connectors
- Fully QPL'd

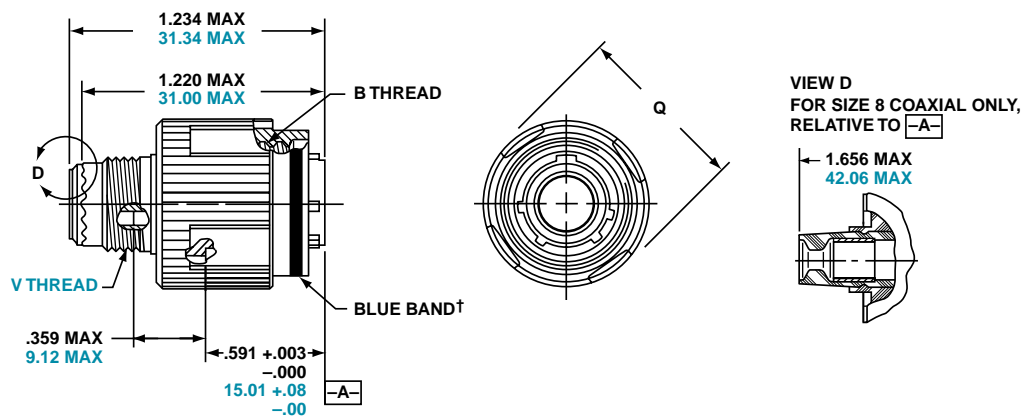

† Blue band indicates rear release contact retention system

| Shell Size | MS Shell Size Code | B Thread 0.1P-0.3L-TS-2B (Plated) | Q Dia. Max. |
|------------|--------------------|-----------------------------------|-------------|
| 9          | A                  | .6250                             | .858        |
| 11         | B                  | .7500                             | .984        |
| 13         | C                  | .8750                             | 1.157       |
| 15         | D                  | 1.0000                            | 1.280       |
| 17         | E                  | 1.1875                            | 1.406       |
| 19         | F                  | 1.2500                            | 1.516       |
| 21         | G                  | 1.3750                            | 1.642       |
| 23         | H                  | 1.5000                            | 1.768       |
| 25         | J                  | 1.6250                            | 1.890       |

| Shell Size | MS Shell Size Code | Q Max. | V Thread Metric |
|------------|--------------------|--------|-----------------|
| 9          | A                  | 21.8   | M12X1-6g        |
| 11         | B                  | 25.0   | M15X1-6g        |
| 13         | C                  | 29.4   | M18X1-6g        |
| 15         | D                  | 32.5   | M22X1-6g        |
| 17         | E                  | 35.7   | M25X1-6g        |
| 19         | F                  | 38.5   | M28X1-6g        |
| 21         | G                  | 41.7   | M31X1-6g        |
| 23         | H                  | 44.9   | M34X1-6g        |
| 25         | J                  | 48.0   | M37X1-6g        |

All dimensions for reference only.

- III 38999 SJT
- Matrix 2 26482
- Matrix Pyle 83723 III
- Release Matrix 5015 Crimp Rear
- 26500 Pyle
- Printed Circuit Board
- EMI Filter Transient
- Fiber Optics
- High Speed Contacts
- Options Others



### Jam Nut Receptacle

38999  
SJT I II III

26482  
Matrix 2

83723 III  
Matrix Pyle

5015  
Crimp Rear  
Release Matrix

26500 Pyle

Printed  
Circuit Board

EMI Filter  
Transient

Fiber Optics

High Speed  
Contacts

Options  
Others

#### PART #

To complete, see how to order pages 22-24.

| Connector Type | Shell Style | Service Class | Shell Size & Insert Arrg | Contact Type | Alternate Position | Special Variations |
|----------------|-------------|---------------|--------------------------|--------------|--------------------|--------------------|
| TV             | 07          | RW            | 9-35                     | P            | B                  | (453)              |
| TVS            | 07          | RK            | X-X                      | X            | X                  | (XXX)              |
| TVS            | 07          | RF            | X-X                      | X            | X                  | (XXX)              |
| TVS            | 07          | RS            | X-X                      | X            | X                  | (XXX)              |
| CTV            | 07          | RW            | X-X                      | X            | X                  | (XXX)              |
| CTVS           | 07          | RF            | X-X                      | X            | X                  | (XXX)              |
| D38999/        | 24          | X             | X-X                      | X            | X                  | NA                 |



† Red band indicates fully mated

†† Blue band indicates rear release contact retention system

★ .059 dia min.

1.5 dia min., 3 lockwire holes Formed lockwire hole design (6 holes) is optional Inches

| Shell Size | MS Shell Size Code | B Thread Class 2A 0.1P-0.3L-TS (Plated) | C Max. | D <sup>1</sup> +.010 - .000 | D <sup>2</sup> +.000 - .010 | H Hex +.017 - .016 | S ±.010 |
|------------|--------------------|---|--------|-----------------------------|-----------------------------|--------------------|---------|
| 9          | A                  | .6250                                   | 1.199  | .700                        | .670                        | .875               | 1.062   |
| 11         | B                  | .7500                                   | 1.386  | .825                        | .770                        | 1.000              | 1.250   |
| 13         | C                  | .8750                                   | 1.511  | 1.010                       | .955                        | 1.188              | 1.375   |
| 15         | D                  | 1.0000                                  | 1.636  | 1.135                       | 1.085                       | 1.312              | 1.500   |
| 17         | E                  | 1.1875                                  | 1.761  | 1.260                       | 1.210                       | 1.438              | 1.625   |
| 19         | F                  | 1.2500                                  | 1.949  | 1.385                       | 1.335                       | 1.562              | 1.812   |
| 21         | G                  | 1.3750                                  | 2.073  | 1.510                       | 1.460                       | 1.688              | 1.938   |
| 23         | H                  | 1.5000                                  | 2.199  | 1.635                       | 1.585                       | 1.812              | 2.062   |
| 25         | J                  | 1.6250                                  | 2.323  | 1.760                       | 1.710                       | 2.000              | 2.188   |

Millimeters

| Shell Size | MS Shell Size Code | C Max. | D <sup>1</sup> +.25 - .00 | D <sup>2</sup> +.00 - .25 | H Hex +.43 - .41 | S ±.25 | V Thread Metric |
|------------|--------------------|--------|---------------------------|---------------------------|------------------|--------|-----------------|
| 9          | A                  | 30.45  | 17.78                     | 17.02                     | 22.23            | 26.97  | M12X1-6g        |
| 11         | B                  | 35.20  | 20.96                     | 19.59                     | 25.40            | 31.75  | M15X1-6g        |
| 13         | C                  | 38.38  | 25.65                     | 24.26                     | 30.18            | 34.93  | M18X1-6g        |
| 15         | D                  | 41.55  | 28.83                     | 27.56                     | 33.32            | 38.10  | M22X1-6g        |
| 17         | E                  | 44.73  | 32.01                     | 30.73                     | 36.53            | 41.28  | M25X1-6g        |
| 19         | F                  | 49.50  | 35.18                     | 33.91                     | 39.67            | 46.02  | M28X1-6g        |
| 21         | G                  | 52.65  | 38.35                     | 37.08                     | 42.80            | 49.23  | M31X1-6g        |
| 23         | H                  | 55.85  | 41.53                     | 40.26                     | 46.02            | 52.37  | M34X1-6g        |
| 25         | J                  | 59.00  | 44.70                     | 43.43                     | 50.80            | 55.58  | M37X1-6g        |

All dimensions for reference only NOTE: Deep reach receptacles are available for panel thicknesses up to .750 max.

# TV01R – Crimp, Metal CTV01R – Crimp, Composite

## Line Receptacle

### PART #

To complete, see how to order pages 22-24.

| Connector Type | Shell Style | Service Class | Shell Size & Insert Arrg | Contact Type | Alternate Position | Special Variations |
|----------------|-------------|---------------|--------------------------|--------------|--------------------|--------------------|
| TV             | 01          | RW            | 9-35                     | P            | B                  | (453)              |
| TVS            | 01          | RF            | X-X                      | X            | X                  | (XXX)              |
| CTV            | 01          | RW            | X-X                      | X            | X                  | (XXX)              |
| CTVS           | 01          | RF            | X-X                      | X            | X                  | (XXX)              |

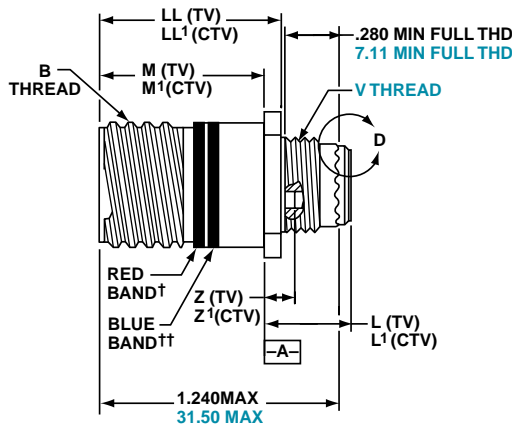

VIEW D  
FOR SIZE 8 COAXIAL ONLY,  
RELATIVE TO -A-



VIEW D  
FOR SIZE 8 TWINAX ONLY,  
RELATIVE TO -A-



† Red band indicates fully mated

†† Blue band indicates rear release contact retention system

Inches

| Shell Size | MS Shell Size Code | B Thread 0.1P-0.3L-TS-2A (Plated) | M +.000 - .005 (TV) | M' +.000 - .005 (CTV) | L Max. (TV) | L' Max. (CTV) | S ±.010 (TV) | S' ±.010 (CTV) | Z Max (TV) | Z' Max (CTV) | GG ±.010 (TV) | GG' ±.010 (CTV) | LL +.006 - .000 (TV) | LL' ±.005 (CTV) |
|------------|--------------------|-----------------------------------|---------------------|-----------------------|-------------|---------------|--------------|----------------|------------|--------------|---------------|-----------------|----------------------|-----------------|
| 9          | A                  | .6250                             | .820                | .773                  | .469        | .514          | .675         | .635           | .153       | .198         | .812          | .699            | .905                 | .908            |
| 11         | B                  | .7500                             | .820                | .773                  | .469        | .514          | .800         | .765           | .153       | .198         | .905          | .875            | .905                 | .908            |
| 13         | C                  | .8750                             | .820                | .773                  | .469        | .514          | .925         | .885           | .153       | .198         | 1.093         | 1.007           | .905                 | .908            |
| 15         | D                  | 1.0000                            | .820                | .773                  | .469        | .514          | 1.050        | 1.100          | .153       | .198         | 1.219         | 1.140           | .905                 | .908            |
| 17         | E                  | 1.1875                            | .820                | .773                  | .469        | .514          | 1.238        | 1.197          | .153       | .198         | 1.375         | 1.229           | .905                 | .908            |
| 19         | F                  | 1.2500                            | .820                | .773                  | .469        | .514          | 1.300        | 1.260          | .153       | .198         | 1.469         | 1.380           | .905                 | .908            |
| 21         | G                  | 1.3750                            | .790                | .741                  | .500        | .545          | 1.425        | 1.385          | .183       | .228         | 1.625         | 1.493           | .905                 | .904            |
| 23         | H                  | 1.5000                            | .790                | .741                  | .500        | .545          | 1.550        | 1.510          | .183       | .228         | 1.750         | 1.626           | .905                 | .904            |
| 25         | J                  | 1.6250                            | .790                | .741                  | .500        | .545          | 1.675        | 1.635          | .183       | .228         | 1.875         | 1.777           | .905                 | .904            |

Millimeters

| Shell Size | MS Shell Size Code | M +.00 - .013 (TV) | M' +.00 - .13 (CTV) | L Max. (TV) | L' Max. (CTV) | S ±.25 (TV) | S' ±.010 (CTV) | V Thread Metric | Z Max (TV) | Z' Max (CTV) | GG ±.25 (TV) | GG' ±.25 (CTV) | LL +.15 - .00 (TV) | LL' ±.13 (CTV) |
|------------|--------------------|--------------------|---------------------|-------------|---------------|-------------|----------------|-----------------|------------|--------------|--------------|----------------|--------------------|----------------|
| 9          | A                  | 20.83              | 19.63               | 11.91       | 13.06         | 17.15       | 16.13          | M12X1-6g        | 3.89       | 5.03         | 20.62        | 17.75          | 22.99              | 23.06          |
| 11         | B                  | 20.83              | 19.63               | 11.91       | 13.06         | 20.32       | 19.43          | M15X1-6g        | 3.89       | 5.03         | 22.99        | 22.22          | 22.99              | 23.06          |
| 13         | C                  | 20.83              | 19.63               | 11.91       | 13.06         | 23.50       | 22.47          | M18X1-6g        | 3.89       | 5.03         | 27.76        | 25.57          | 22.99              | 23.06          |
| 15         | D                  | 20.83              | 19.63               | 11.91       | 13.06         | 26.67       | 27.94          | M22X1-6g        | 3.89       | 5.03         | 30.96        | 28.95          | 22.99              | 23.06          |
| 17         | E                  | 20.83              | 19.63               | 11.91       | 13.06         | 31.45       | 30.40          | M25X1-6g        | 3.89       | 5.03         | 34.93        | 31.21          | 22.99              | 23.06          |
| 19         | F                  | 20.83              | 19.63               | 11.91       | 13.06         | 33.02       | 32.00          | M28X1-6g        | 3.89       | 5.03         | 37.31        | 35.05          | 22.99              | 23.06          |
| 21         | G                  | 20.07              | 18.82               | 12.70       | 13.84         | 36.20       | 35.18          | M31X1-6g        | 4.65       | 5.79         | 41.28        | 37.92          | 22.99              | 22.96          |
| 23         | H                  | 20.07              | 18.82               | 12.70       | 13.84         | 39.37       | 38.35          | M34X1-6g        | 4.65       | 5.79         | 44.45        | 41.30          | 22.99              | 22.96          |
| 25         | J                  | 20.07              | 18.82               | 12.70       | 13.84         | 42.55       | 41.53          | M37X1-6g        | 4.65       | 5.79         | 47.63        | 45.13          | 22.99              | 22.96          |

All dimensions for reference only

38999  
SJT

26482  
Matrix 2

83723 III  
Matrix Pyle

5015  
Crimp Rear Release Matrix

26500 Pyle

Printed  
Circuit Board

EM I Filter  
Transient

Fiber Optics

High Speed  
Contacts

Options  
Others

38999

SJT

26482 Matrix 2

83723 III Matrix Pyle

5015 Crimp Rear Release Matrix

26500 Pyle

Printed Circuit Board

EMI Filter Transient

Fiber Optics

High Speed Contacts

Options Others

### PART #

To complete, see how to order pages 22-24.

| Connector Type | Shell Style | Service Class | Shell Size & Insert Arrg | Contact Type | Alternate Position | Special Variations |
|----------------|-------------|---------------|--------------------------|--------------|--------------------|--------------------|
| TV             | 09          | RW            | 9-35                     | P            | B                  | (453)              |
| TVS            | 09          | RF            | X-X                      | X            | X                  | (000X)             |



† Blue band indicates rear release contact retention system

Inches

| Shell Size | MS Shell Size Coded | B Thread 0.1P-0.3L-TS-2A (Plated) | G ±.060 | Q Dia. Max | R     | GG Dia ±.005 |
|------------|---------------------|-----------------------------------|---------|------------|-------|--------------|
| 9**        | A                   | .6250                             | 1.106   | .859       | 1.038 | 1.838        |
| 11         | B                   | .7500                             | 1.106   | .969       | 1.115 | 1.948        |
| 13**       | C                   | .8750                             | 1.106   | 1.141      | 1.240 | 2.124        |
| 15         | D                   | 1.0000                            | 1.106   | 1.266      | 1.327 | 2.248        |
| 17         | E                   | 1.1875                            | 1.106   | 1.391      | 1.417 | 2.375        |
| 19         | F                   | 1.2500                            | 1.356   | 1.500      | 1.557 | 2.495        |
| 21         | G                   | 1.3750                            | 1.356   | 1.625      | 1.624 | 2.568        |
| 23         | H                   | 1.5000                            | 1.356   | 1.750      | 1.713 | 2.723        |
| 25         | J                   | 1.6250                            | 1.356   | 1.875      | 1.801 | 2.848        |

Millimeters

| Shell Size | MS Shell Size Coded | G ±.152 | Q Dia. Max | R     | GG Dia ±.13 |
|------------|---------------------|---------|------------|-------|-------------|
| 9**        | A                   | 28.09   | 21.82      | 26.37 | 46.69       |
| 11         | B                   | 28.09   | 24.62      | 28.32 | 49.48       |
| 13**       | C                   | 28.09   | 28.98      | 31.50 | 53.95       |
| 15         | D                   | 28.09   | 32.16      | 33.71 | 57.10       |
| 17         | E                   | 28.09   | 35.33      | 35.99 | 60.33       |
| 19         | F                   | 34.44   | 38.10      | 39.55 | 63.37       |
| 21         | G                   | 34.44   | 41.28      | 41.25 | 65.23       |
| 23         | H                   | 34.44   | 44.45      | 43.51 | 69.16       |
| 25         | J                   | 34.44   | 47.63      | 45.75 | 72.34       |

All dimensions for reference only

\*\* Partially tooled. Consult Amphenol Aerospace for availability

  Designates true position dimensioning

# TVPS02Y (D38999/21) – Hermetic

## Stainless Steel

### Box Mounting Receptacle

#### PART #

To complete, see how to order pages 22-24.

| Connector Type | Shell Style | Service Class | Shell Size & Insert Arrg | Contact Type | Alternate Position | Special Variations |
|----------------|-------------|---------------|--------------------------|--------------|--------------------|--------------------|
| TVPS           | 02          | Y             | 9-35                     | P            | B                  | (453)              |
| TVPS           | 02          | YN            | X-X                      | X            | X                  | (XXX)              |
| D38999/        | 21          | X             | X-X                      | X            | X                  | NA                 |



† Red band indicates fully mated

NOTE: Consult Amphenol Aerospace for availability of non-glass-sealed versions with printed circuit tail contacts.

Inches

| Shell Size | MS Shell Size Coded | B Thread 0.1P-0.3L-TS (Plated) | R1    | R2    | S ±.010 | T ±.008 | TT ±.008 |
|------------|---------------------|--------------------------------|-------|-------|---------|---------|----------|
| 9          | A                   | .6250                          | .719  | .594  | .938    | .128    | .216     |
| 11         | B                   | .7500                          | .812  | .719  | 1.031   | .128    | .194     |
| 13         | C                   | .8750                          | .906  | .812  | 1.125   | .128    | .194     |
| 15         | D                   | 1.0000                         | .969  | .906  | 1.219   | .128    | .173     |
| 17         | E                   | 1.1875                         | 1.062 | .969  | 1.312   | .128    | .194     |
| 19         | F                   | 1.2500                         | 1.156 | 1.062 | 1.438   | .128    | .194     |
| 21         | G                   | 1.3750                         | 1.250 | 1.156 | 1.562   | .128    | .194     |
| 23         | H                   | 1.5000                         | 1.375 | 1.250 | 1.688   | .154    | .242     |
| 25         | J                   | 1.6250                         | 1.500 | 1.375 | 1.812   | .154    | .242     |

Millimeters

| Shell Size | MS Shell Size Coded | R1    | R2    | S ±.25 | T ±.20 | TT ±.20 |
|------------|---------------------|-------|-------|--------|--------|---------|
| 9          | A                   | 18.26 | 15.09 | 23.83  | 3.25   | 5.49    |
| 11         | B                   | 20.62 | 18.26 | 26.19  | 3.25   | 4.93    |
| 13         | C                   | 23.01 | 20.62 | 28.58  | 3.25   | 4.93    |
| 15         | D                   | 24.61 | 23.01 | 30.96  | 3.25   | 4.39    |
| 17         | E                   | 26.97 | 24.61 | 33.32  | 3.25   | 4.93    |
| 19         | F                   | 29.36 | 26.97 | 36.53  | 3.25   | 4.93    |
| 21         | G                   | 31.75 | 29.36 | 39.67  | 3.25   | 4.93    |
| 23         | H                   | 34.93 | 31.75 | 42.88  | 3.91   | 6.15    |
| 25         | J                   | 38.10 | 34.93 | 46.02  | 3.91   | 6.15    |

All dimensions for reference only

Designates true position dimensioning

- III 38999
- II
- I
- SJT
- 26482 Matrix 2
- 83723 III Matrix Pyle
- 5015 Crimp Rear Release Matrix
- 26500 Pyle
- Printed Circuit Board
- EMI Filter Transient
- Fiber Optics
- High Speed Contacts
- Options Others

### Jam Nut Receptacle

38999

III  
II  
I  
SJT

26482

Matrix 2

83723 III

Matrix Pyle

5015

Crimp Rear  
Release Matrix

26500 Pyle

Printed  
Circuit Board

EMI Filter  
Transient

Fiber Optics

High Speed  
Contacts

Options  
Others

#### PART #

To complete,  
see how to order  
pages 22-24.

| Connector Type | Shell Style | Service Class | Shell Size & Insert Arrg | Contact Type | Alternate Position | Special Variations |
|----------------|-------------|---------------|--------------------------|--------------|--------------------|--------------------|
| TVS            | 07          | Y             | 9-35                     | P            | B                  | (453)              |
| TVS            | 07          | YN            | X-X                      | X            | X                  | (XXX)              |
| D38999/        | 23          | X             | X-X                      | X            | X                  | NA                 |

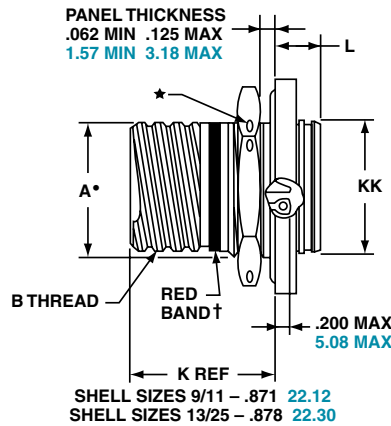
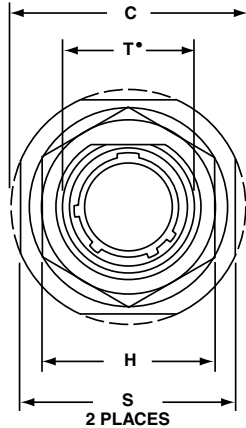

#### PANEL HOLE DIMENSIONS

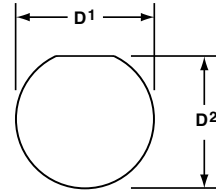

JAM NUT  
D-HOLE  
MOUNTING

† Red band indicates fully mated

★ .059 dia min.

1.5 dia min. 3 lockwire holes

Formed lockwire hole design (6 holes) is optional.

Inches

| Shell Size | MS Shell Size code | A* +.000<br>-.010 | B Thread Class 2A<br>0.1P-<br>0.3L-TS<br>(Plated) | C Max | D <sup>1</sup> +.010<br>-.000 | D <sup>2</sup> +.000<br>-.010 | H Hex<br>+.017<br>-.016 | L Max | S ±.010 | T* +.010<br>-.000 | KK +.011<br>-.000 |
|------------|--------------------|-------------------|---|-------|-------------------------------|-------------------------------|-------------------------|-------|---------|-------------------|-------------------|
| 9          | A                  | .669              | .6250   | 1.199 | .700                          | .670                          | .875                    | .357  | 1.062   | .697              | .642              |
| 11         | B                  | .769              | .7500   | 1.386 | .825                          | .770                          | 1.000                   | .357  | 1.250   | .822              | .766              |
| 13         | C                  | .955              | .8750   | 1.511 | 1.010                         | .955                          | 1.188                   | .357  | 1.375   | 1.007             | .892              |
| 15         | D                  | 1.084             | 1.0000  | 1.636 | 1.135                         | 1.085                         | 1.312                   | .357  | 1.500   | 1.134             | 1.018             |
| 17         | E                  | 1.208             | 1.1875  | 1.761 | 1.260                         | 1.210                         | 1.438                   | .357  | 1.625   | 1.259             | 1.142             |
| 19         | F                  | 1.333             | 1.2500  | 1.949 | 1.385                         | 1.335                         | 1.562                   | .381  | 1.812   | 1.384             | 1.268             |
| 21         | G                  | 1.459             | 1.3750  | 2.073 | 1.510                         | 1.460                         | 1.688                   | .381  | 1.938   | 1.507             | 1.392             |
| 23         | H                  | 1.575             | 1.5000  | 2.199 | 1.635                         | 1.585                         | 1.812                   | .381  | 2.062   | 1.634             | 1.518             |
| 25         | J                  | 1.709             | 1.6250  | 2.323 | 1.760                         | 1.710                         | 2.000                   | .381  | 2.188   | 1.759             | 1.642             |

Millimeters

| Shell Size | MS Shell Size code | A* +.00 --.25 | C Max | D <sup>1</sup> +.25 --.00 | D <sup>2</sup> +.00 --.25 | H Hex<br>+.43<br>-.41 | L Max | S ±.25 | T* +.25<br>-.00 | KK +.28<br>-.00 |
|------------|--------------------|---------------|-------|---------------------------|---------------------------|-----------------------|-------|--------|-----------------|-----------------|
| 9          | A                  | 16.99         | 30.45 | 17.78                     | 17.02                     | 22.23                 | 9.07  | 26.97  | 17.70           | 16.31           |
| 11         | B                  | 19.53         | 35.20 | 20.96                     | 19.59                     | 25.40                 | 9.07  | 31.75  | 20.88           | 19.46           |
| 13         | C                  | 24.26         | 38.38 | 25.65                     | 24.26                     | 30.18                 | 9.07  | 34.93  | 25.58           | 22.66           |
| 15         | D                  | 27.53         | 41.55 | 28.83                     | 27.56                     | 33.32                 | 9.07  | 38.10  | 28.80           | 25.86           |
| 17         | E                  | 30.68         | 44.73 | 32.01                     | 30.73                     | 36.53                 | 9.07  | 41.28  | 31.98           | 29.01           |
| 19         | F                  | 33.86         | 49.50 | 35.18                     | 33.91                     | 39.67                 | 9.68  | 46.02  | 35.15           | 32.21           |
| 21         | G                  | 37.06         | 52.65 | 38.35                     | 37.08                     | 42.80                 | 9.68  | 49.23  | 38.28           | 35.36           |
| 23         | H                  | 40.01         | 55.85 | 41.53                     | 40.26                     | 46.02                 | 9.68  | 52.37  | 41.50           | 38.56           |
| 25         | J                  | 43.41         | 59.00 | 44.70                     | 43.43                     | 50.80                 | 9.68  | 55.58  | 44.68           | 41.71           |

All dimensions for reference only

• D shaped panel cut-out dimensions



# TVSIY (D38999/25) – Hermetic Stainless Steel

## Solder Mounting Receptacle

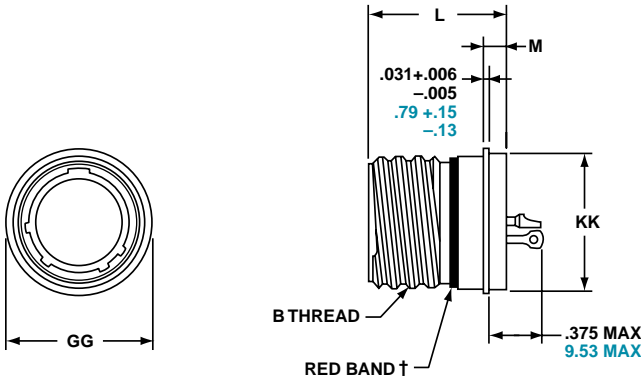

### PART #

To complete, see how to order pages 22-24.

| Connector Type | Shell Style | Service Class | Shell Size & Insert Arrg | Contact Type | Alternate Position | Special Variations |
|----------------|-------------|---------------|--------------------------|--------------|--------------------|--------------------|
| TVS            | I           | Y             | 9-35                     | P            | B                  | (453)              |
| TVS            | I           | YN            | X-X                      | X            | X                  | (XXX)              |
| D38999/        | 25          | X             | X-X                      | X            | X                  | NA                 |

† Red band indicates fully mated

Inches

| Shell Size | MS Shell Size Code | B Thread Class 2A 0.1P-0.3L-TS (Plated) | L +.011 - .005 | M +.006 - .005 | GG Dia. +.011 - .010 | KK Dia +.011 - .005 |
|------------|--------------------|---|----------------|----------------|----------------------|---------------------|
| 9          | A                  | .6250                                   | .806           | .125           | .750                 | .672                |
| 11         | B                  | .7500                                   | .806           | .125           | .844                 | .781                |
| 13         | C                  | .8750                                   | .806           | .125           | .969                 | .906                |
| 15         | D                  | 1.0000                                  | .806           | .125           | 1.094                | 1.031               |
| 17         | E                  | 1.1875                                  | .806           | .125           | 1.218                | 1.156               |
| 19         | F                  | 1.2500                                  | .806           | .125           | 1.312                | 1.250               |
| 21         | G                  | 1.3750                                  | .806           | .125           | 1.438                | 1.375               |
| 23         | H                  | 1.5000                                  | .838           | .156           | 1.563                | 1.500               |
| 25         | J                  | 1.6250                                  | .838           | .156           | 1.688                | 1.625               |

Millimeters

| Shell Size | MS Shell Size Code | L +.28 - .00 | M +.15 - .13 | GG Dia. +.28 - .25 | KK Dia +.03 - .13 |
|------------|--------------------|--------------|--------------|--------------------|-------------------|
| 9          | A                  | 20.47        | 3.18         | 19.05              | 17.07             |
| 11         | B                  | 20.47        | 3.18         | 21.44              | 19.84             |
| 13         | C                  | 20.47        | 3.18         | 24.61              | 23.01             |
| 15         | D                  | 20.47        | 3.18         | 27.79              | 26.19             |
| 17         | E                  | 20.47        | 3.18         | 30.94              | 29.36             |
| 19         | F                  | 20.47        | 3.18         | 33.32              | 31.75             |
| 21         | G                  | 20.47        | 3.18         | 36.53              | 34.93             |
| 23         | H                  | 21.29        | 3.96         | 39.70              | 38.10             |
| 25         | J                  | 21.29        | 3.96         | 42.88              | 41.28             |

# TVSHIY (D38999/27) – Hermetic, Stainless Steel

## Weld Mounting Receptacle

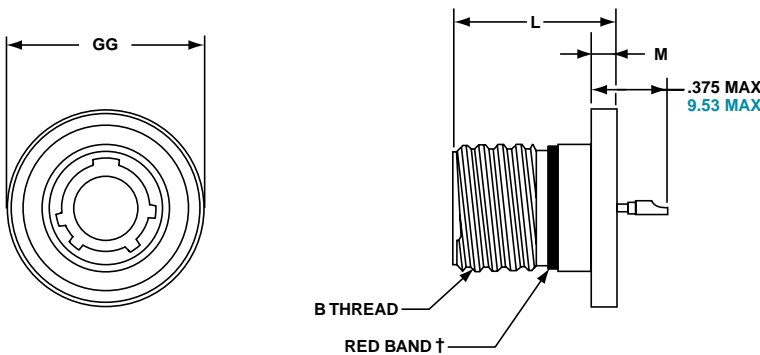

### PART #

To complete, see how to order pages 22-24.

| Connector Type | Shell Style | Service Class | Shell Size & Insert Arrg | Contact Type | Alternate Position | Special Variations |
|----------------|-------------|---------------|--------------------------|--------------|--------------------|--------------------|
| TVS            | HI          | Y             | 9-35                     | P            | B                  | (453)              |
| TVS            | HI          | YN            | X-X                      | X            | X                  | (XXX)              |
| D38999/        | 27          | X             | X-X                      | X            | X                  | NA                 |

† Red band indicates fully mated

Inches

| Shell Size | MS Shell Size Code | B Thread Class 2A 0.1P-0.3L-TS (Plated) | L +.011 - .000 | M +.006 - .005 | GG Dia. +.011 - .010 |
|------------|--------------------|---|----------------|----------------|----------------------|
| 9          | A                  | .6250                                   | .806           | .125           | .973                 |
| 11         | B                  | .7500                                   | .806           | .125           | 1.095                |
| 13         | C                  | .8750                                   | .806           | .125           | 1.221                |
| 15         | D                  | 1.0000                                  | .806           | .125           | 1.347                |
| 17         | E                  | 1.1875                                  | .806           | .125           | 1.434                |
| 19         | F                  | 1.2500                                  | .806           | .125           | 1.579                |
| 21         | G                  | 1.3750                                  | .806           | .125           | 1.721                |
| 23         | H                  | 1.5000                                  | .838           | .156           | 1.886                |
| 25         | J                  | 1.6250                                  | .838           | .156           | 1.973                |

Millimeters

| Shell Size | MS Shell Size Code | L +.28 - .00 | M +.15 - .13 | GG Dia. +.25 - .00 |
|------------|--------------------|--------------|--------------|--------------------|
| 9          | A                  | 20.47        | 3.18         | 24.71              |
| 11         | B                  | 20.47        | 3.18         | 27.81              |
| 13         | C                  | 20.47        | 3.18         | 31.01              |
| 15         | D                  | 20.47        | 3.18         | 34.21              |
| 17         | E                  | 20.47        | 3.18         | 36.42              |
| 19         | F                  | 20.47        | 3.18         | 40.11              |
| 21         | G                  | 20.47        | 3.18         | 43.71              |
| 23         | H                  | 21.29        | 3.96         | 47.90              |
| 25         | J                  | 21.29        | 3.96         | 50.11              |

All dimensions for reference only

- III 38999
- II
- I
- SJT
- 26482 Matrix 2
- 83723 III Matrix Pyle
- 5015 Crimp Rear Release Matrix
- 26500 Pyle
- Printed Circuit Board
- EMI Filter Transient
- Fiber Optics
- High Speed Contacts
- Options Others

38999  
SJT I II III

26482  
Matrix 2

83723 III  
Matrix Pyle

5015  
Crimp Rear Release Matrix

26500 Pyle

Printed  
Circuit Board

EMI Filter  
Transient

Fiber Optics

High Speed  
Contacts

Options  
Others

**Amphenol® Tri-Start Breakaway Fail Safe Connectors provide unequalled performance in environments requiring instant disengagement.**

Designed to provide quick disconnect of a connector plug and receptacle with an axial pull on the lanyard, the "Breakaway" Fail Safe connector family offers a wide range of electrical and mechanical features:

- Instant decoupling and damage free separation
- Completely intermateable with standard receptacles (D38999/20 and /24)
- Inventory support commonality through the use of standard insert arrangements and contacts

Breakaway un-mating is initiated by applying a pull force to the lanyard which causes the operating sleeve on the plug to move away from the receptacle. Coupling segments on the plug then move away from the mating receptacle while expanding, thus releasing the receptacle. After completion of the un-mating sequence, spring compression returns the sleeve and segments to their original positions. Un-mating of the plug may also be accomplished by normal rotation of the coupling ring without affecting the breakaway capability.



**Amphenol offers a variety of lanyard plug styles including MIL-STD-1760 types 1, 2 and 6 for Stores Management applications.**

**The Tri-Start Breakaway Fail Safe connector exceeds the MIL-Spec Series III requirements for EMI/EMP shielding and features include:**

- Solid metal-to-metal coupling
- EMI grounding fingers
- Conductive finishes

**Amphenol Breakaway Fail Safe connectors are qualified to MIL-DTL-38999/29, /30 and /31 (for MIL-STD-1760 Stores Management applications). In fact, Amphenol offers more qualified Breakaway shell size and insert combinations than any other QPL supplier.**

In addition to standard Breakaway connectors, Amphenol also manufactures custom breakaway connectors including those with:

- Highly durable non-metallic operating sleeves in a variety of lengths and diameters
- Increased pull-force capability
- Low-profile designs
- Custom lanyard lengths and backshells
- Low force separation capabilities
- Low insertion/separation force contacts
- Non-cadmium finishes

Whether you need a standard Breakaway, one of our custom Breakaways or, a unique Breakaway design, please contact your local Amphenol representative.

Contact Amphenol Aerospace for more information on breakaway, quick-disconnect connectors. Other Amphenol circular families (MIL-DTL-26482, MIL-DTL-83723) also offer breakaway quick-disconnect connectors.

See accessories for breakaway connectors on page 90.



**Breakaway with Coax Contacts**



**Special configuration Fail Safe used on space telescope application. Lanyard is replaced by a swivel ring for remote disconnect and "wing arms" have been added for manual actuation accessibility by gloved astronauts.**

| <b>PART #</b>                              | Connector Type | Shell Style | Shell Size & Insert Arrg | Lanyard Length Code | Contact Type/<br>Alternate Insert Rotation |                |
|--|----------------|-------------|--------------------------|---------------------|--|----------------|
| To complete, see how to order pages 38-39. | D38999         | 29          | 29                       | E                   | P  | (Pins Only)    |
|  | D38999         | 30          | X-X                      | X                   | X  | (Sockets Only) |
|  | 88             | 5565        | X-X                      | X                   | X  |                |
|  | 91             | 5565        | X-X                      | X                   | X  |                |

#### METAL

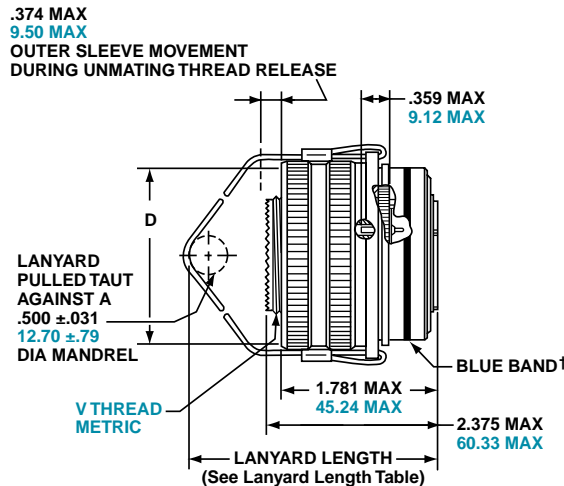

† Blue band indicates rear release contact retention system

Inches

| Shell Size | MS Shell Size Code | B Max | D Max Accessory Dia. |
|------------|--------------------|-------|----------------------|
| 11         | B                  | 1.846 | 1.109                |
| 13         | C                  | 1.972 | 1.250                |
| 15         | D                  | 2.079 | 1.375                |
| 17         | E                  | 2.205 | 1.500                |
| 19         | F                  | 2.301 | 1.625                |
| 21         | G                  | 2.472 | 1.750                |
| 23         | H                  | 2.594 | 1.875                |
| 25         | J                  | 2.705 | 2.000                |

Millimeters

| Shell Size | MS Shell Size Code | B Max | D Max Accessory Dia. | V Thread Metric |
|------------|--------------------|-------|----------------------|-----------------|
| 11         | B                  | 46.89 | 28.17                | M15X1.0-6g      |
| 13         | C                  | 50.09 | 31.75                | M18X1.0-6g      |
| 15         | D                  | 52.81 | 34.93                | M22X1.0-6g      |
| 17         | E                  | 56.01 | 38.10                | M25X1.0-6g      |
| 19         | F                  | 58.45 | 41.28                | M28X1.0-6g      |
| 21         | G                  | 62.79 | 44.45                | M31X1.0-6g      |
| 23         | H                  | 65.89 | 47.63                | M34X1.0-6g      |
| 25         | J                  | 68.71 | 50.08                | M37X1.0-6g      |

All dimensions for reference only

- III 38999
- II
- I
- SJT
- 26482 Matrix 2
- 83723 III Matrix Pyle
- 5015 Crimp Rear Release Matrix
- 26500 Pyle
- Printed Circuit Board
- EMI Filter Transient
- Fiber Optics
- High Speed Contacts
- Options Others

### Easy Steps to build a part number... **Military**

| 1.                | 2.                | 3.            | 4.         | 5.                 | 6.                  | 7.                        |
|-------------------|-------------------|---------------|------------|--------------------|---------------------|---------------------------|
| DOD Number Prefix | Spec Sheet Number | Service Class | Shell Size | Insert Arrangement | Lanyard Length Code | Alternate Keying Position |
| D38999/           | 29                | F             | E          | 6                  | P                   | N                         |

#### Step 1. DOD Number Prefix

D38999/ designates MIL-DTL-38999, Series III, Tri-Start Connector

#### Step 2. Select a Specification Sheet Number

|    |  |
|----|--|
| 29 | Designates Lanyard Release Plug with pin contacts    |
| 30 | Designates Lanyard Release Plug with socket contacts |

#### Step 3. Select a Service Class

|          |   |
|----------|---|
| <b>F</b> | Designates electroless nickel plated aluminum, optimum EMI shielding effectiveness –65dB@10 GHz specification min., 48 hour salt spray, 200°C |
| <b>W</b> | Designates corrosion resistant olive drab cadmium plate aluminum, 500 hour extended salt spray, EMI –50dB@10 GHz specification min., 175°C    |

#### Step 4. & 5 Insert Availability

| Commercial Basic Part#<br>Shell & Insert Arrg. Code | Shell Size-Insert Arrangement | Military Shell Size-Insert Arrangement | Service Rating | Total Contacts | Contact Size |    |    |    |         |        |          |   |
|---|-------------------------------|--|----------------|----------------|--------------|----|----|----|---------|--------|----------|---|
|   |                               |  |                |                | 22D          | 20 | 16 | 12 | 12 Coax | 8 Coax | 8 Twinax |   |
| 88/91-556508  | 11-2                          | *                                      | I              | 2              |              |    | 2  |    |         |        |          |   |
| 06  | 11-35                         | *                                      | M              | 13             | 13           |    |    |    |         |        |          |   |
| 07  | 11-98                         | *                                      | I              | 6              |              | 6  |    |    |         |        |          |   |
| 10  | 13-4                          | *                                      | I              | 4              |              |    | 4  |    |         |        |          |   |
| 11  | 13-8                          | *                                      | I              | 8              |              | 8  |    |    |         |        |          |   |
| 14  | 13-35                         | *                                      | M              | 22             | 22           |    |    |    |         |        |          |   |
| 13  | 13-98                         | *                                      | I              | 10             |              | 10 |    |    |         |        |          |   |
| 18  | 15-5                          | *                                      | II             | 5              |              |    | 5  |    |         |        |          |   |
| 23  | 15-15                         | *                                      | I              | 15             |              | 14 | 1  |    |         |        |          |   |
| 22  | 15-18                         | *                                      | I              | 18             |              | 18 |    |    |         |        |          |   |
| 19  | 15-19                         | *                                      | I              | 19             |              | 19 |    |    |         |        |          |   |
| 20  | 15-35                         | *                                      | M              | 37             | 37           |    |    |    |         |        |          |   |
| 21  | 15-97                         | *                                      | I              | 12             |              | 8  | 4  |    |         |        |          |   |
| 33  | 17-2                          | E-2                                    | M              | 39             | 38           |    |    |    |         |        |          | 1 |
| 27  | 17-6                          | E-6                                    | I              | 6              |              |    |    | 6  |         |        |          |   |
| 28  | 17-8                          | E-8                                    | II             | 8              |              |    | 8  |    |         |        |          |   |
| 29  | 17-26                         | E-26                                   | I              | 26             |              | 26 |    |    |         |        |          |   |
| 30  | 17-35                         | E-35                                   | M              | 55             | 55           |    |    |    |         |        |          |   |
| 31  | 17-99                         | E-99                                   | I              | 23             |              | 21 | 2  |    |         |        |          |   |
| 37  | 19-11                         | F-11                                   | II             | 11             |              |    | 11 |    |         |        |          |   |
| 41  | 19-18                         | F-18                                   | M              | 18             | 14           |    |    |    |         |        |          | 4 |
| 38  | 19-28                         | F-28                                   | I              | 28             |              | 26 | 2  |    |         |        |          |   |
| 39  | 19-32                         | F-32                                   | I              | 32             |              | 32 |    |    |         |        |          |   |
| 40  | 19-35                         | F-35                                   | M              | 66             | 66           |    |    |    |         |        |          |   |
| 47  | 21-11                         | G-11                                   | I              | 11             |              |    |    | 11 |         |        |          |   |
| 48  | 21-16                         | G-16                                   | II             | 16             |              |    | 16 |    |         |        |          |   |
| 49  | 21-35                         | G-35                                   | M              | 79             | 79           |    |    |    |         |        |          |   |
| 51  | 21-39                         | G-39                                   | I              | 39             |              | 37 | 2  |    |         |        |          |   |
| 50  | 21-41                         | G-41                                   | I              | 41             |              | 41 |    |    |         |        |          |   |
| 57  | 23-21                         | H-21                                   | II             | 21             |              |    | 21 |    |         |        |          |   |
| 58  | 23-35                         | H-35                                   | M              | 100            | 100          |    |    |    |         |        |          |   |
| 59  | 23-53                         | H-53                                   | I              | 53             |              | 53 |    |    |         |        |          |   |
| 61  | 23-54                         | *                                      | M              | 53             | 40           |    | 9  | 4  |         |        |          |   |
| 60  | 23-55                         | *                                      | I              | 55             |              | 55 |    |    |         |        |          |   |
| 71  | 25-4                          | J-4                                    | I              | 56             |              | 48 | 8  |    |         |        |          |   |
| 63  | 25-7                          | J-7                                    | M/Twinax       | 99             | 97           |    |    |    |         |        | 2        |   |
| 64  | 25-8                          | J-8                                    | Twinax         | 8              |              |    |    |    |         |        |          | 8 |
| 66  | 25-19                         | J-19                                   | I              | 19             |              |    |    | 19 |         |        |          |   |
| 74  | 25-20                         | J-20                                   | N              | 30             |              | 10 | 13 |    | 4       |        |          | 3 |
| 72  | 25-24                         | J-24                                   | I              | 24             |              |    | 12 | 12 |         |        |          |   |
| 67  | 25-29                         | J-29                                   | I              | 29             |              |    | 29 |    |         |        |          |   |
| 68  | 25-35                         | J-35                                   | M              | 128            | 128          |    |    |    |         |        |          |   |
| 69  | 25-43                         | J-43                                   | I              | 43             |              | 23 | 20 |    |         |        |          |   |
| 65  | 25-46                         | *                                      | I              | 46             |              | 40 | 4  |    |         | 2*     |          |   |
| 70  | 25-61                         | J-61                                   | I              | 61             |              | 61 |    |    |         |        |          |   |
| 73  | 25-90                         | J-90                                   | I              | 46             |              | 40 | 4  |    |         |        | 2        |   |

\*Not Mil Qualified



## Step 6. Military/ Commercial Lanyard Length Code

Table II

| Lanyard Length (in.) ± .236 | Lanyard Length (mm) ± 6.0 | Lanyard Length Code For Part Number |
|-----------------------------|---------------------------|-------------------------------------|
| 4.016                       | 102                       | A                                   |
| 4.528                       | 115                       | B                                   |
| 5.000                       | 127                       | C                                   |
| 5.512                       | 140                       | D                                   |
| 6.024                       | 153                       | E                                   |
| 6.535                       | 166                       | F                                   |
| 7.008                       | 178                       | G                                   |
| 7.520                       | 191                       | H                                   |
| 7.992                       | 203                       | I                                   |
| 8.503                       | 216                       | J                                   |
| 9.016                       | 229                       | K                                   |
| 9.528                       | 242                       | L                                   |
| 10.000                      | 254                       | M                                   |
| 10.512                      | 267                       | N                                   |
| 11.024                      | 280                       | P                                   |
| 11.535                      | 293                       | R                                   |
| 12.008                      | 305                       | S                                   |
| 12.520                      | 318                       | T                                   |
| 13.031                      | 331                       | U                                   |
| 14.016                      | 356                       | V                                   |
| 15.000                      | 381                       | W                                   |
| 16.024                      | 407                       | X                                   |
| 17.008                      | 432                       | Y                                   |
| 18.031                      | 458                       | Z                                   |

## Step 7. Military Alternate Keying Position

For alternate positions of connector (to prevent cross-mating) see alternate positioning on page 24. (N indicates normal)

## Easy Steps to build a part number... Commercial

**FAIL SAFE 88-5565( ) & 91-5565( )**

Ordering procedure for example part number 88-556529-EP is shown below:

| 1.            | 2.                            | 3.                             | 4.             | 5.                  | 6.                                     |
|---------------|-------------------------------|--------------------------------|----------------|---------------------|--|
| Service Class | Connector Type Identification | Shell Size & Insert Arrg. Code | Required Field | Lanyard Length Code | Contact Type/Alternate Keying Position |
| 88            | 5565                          | 29                             | 0              | E                   | P                                      |

### Step 1. Select a Service Class

|    |   |
|----|---|
| 88 | Designates corrosion resistant olive drab cadmium plate over nickel, 500 hour extended salt spray, EMI -50dB @ 10 GHz specification min., 175°C |
| 91 | Designates electroless nickel plated aluminum, optimum EMI shielding effectiveness -65dB @ 10 GHz specification min., 48 hour salt spray, 200°C |

These are standard finishes. Consult Amphenol Aerospace, Sidney, NY for other variations.

### Step 2. Select a Connector Type Identification

|      |   |
|------|---|
| 5565 | Designates MIL-DTL-38999, Series III Tri-Start Lanyard Release Plug |
|------|---|

### Step 3. Select a Commercial Shell Size & Insert Arrangement Code

MIL-DTL-38999, see insert availability chart on page 38.

### Step 4. Required Field

|   |                                  |
|---|----------------------------------|
| 0 | The required field is always a 0 |
|---|----------------------------------|

### Step 5. Select a Lanyard Length Code

See Table II (to the left) for lanyard length code number.

### Step 6. Select a Contact Type/Alternate Keying Position

P designates pin, S designates socket for normal positioning of contacts. When an alternate position of the connector is required to prevent cross-mating, a different letter (other than P or S) is used. See alternate positioning on page 24, then convert to Amphenol Commercial coding by the following chart.

| Pin Contacts |                 | Socket Contacts |                 |
|--------------|-----------------|-----------------|-----------------|
| MS Letter    | Amphenol letter | MS Letter       | Amphenol Letter |
| PN           | P (normal)      | SN              | S (normal)      |
| PA           | G               | SA              | H               |
| PB           | I               | SB              | J               |
| PC           | K               | SC              | L               |
| PD           | M               | SD              | N               |
| PE           | R               | SE              | T               |

- III 38999
- II
- I
- SJT
- Matrix 2 26482
- Matrix Pyle 83723 III
- Crimp Rear Release Matrix 5015
- 26500 Pyle
- Printed Circuit Board
- EMI Filter Transient
- Fiber Optics
- High Speed Contacts
- Options Others

- 38999 III
- SJT I II
- 26482 Matrix 2
- 83723 III Pyle
- Matrix Pyle
- 5015 Crimp Rear Release Matrix
- 26500 Pyle
- Printed Circuit Board
- EMI Filter Transient
- Fiber Optics
- High Speed Contacts
- Options Others

PIN CONTACTS ONLY,  
SHELL SIZE 25 ONLY

\*Part number reference.  
To complete, see how to order  
page 41.

D38999/31  
88-555875/76 } Type 6  
91-555875/76 }  
88-558518/19 } Type 2  
91-558518/19 }  
T3W-16B25-XXXX — Type 1

\*To order by Commercial Part  
numbers consult Amphenol.

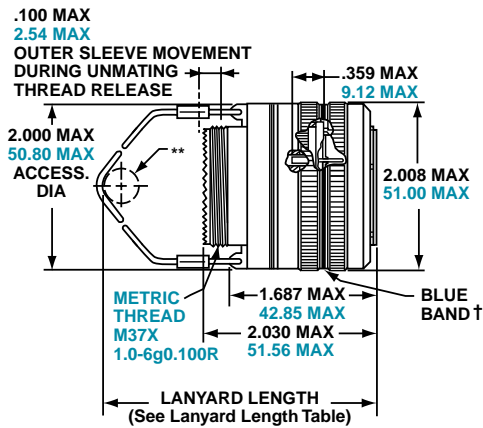

TYPE 6

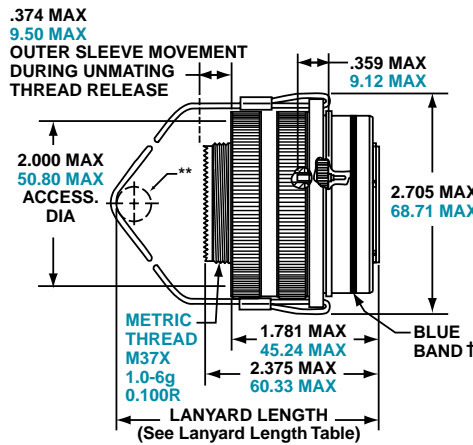

TYPE 2

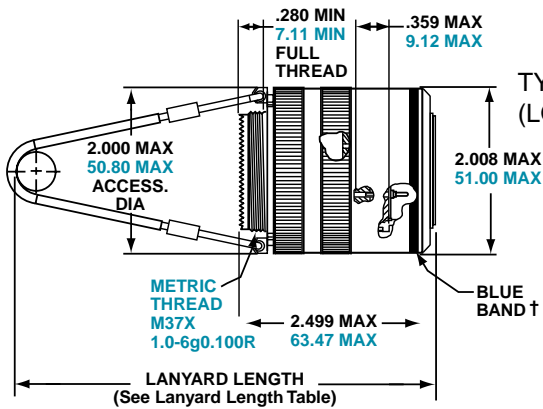

TYPE 1  
(LONGER SHELL)

| Tri-Start Lanyard Separation Forces |                           |                            |
|-------------------------------------|---------------------------|----------------------------|
| Shell Size                          | Straight Plug (lbs. max.) | 15 Degree Pull (lbs. max.) |
| 25                                  | 90                        | 100                        |

**INSERT AVAILABILITY  
FAIL SAFE D38999/31  
FOR MIL-STD-1760**

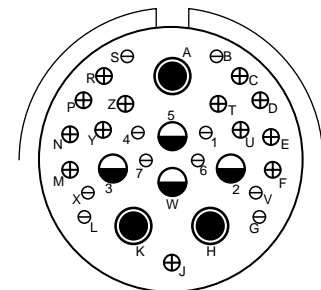

25-20

Primary Interface Signal Set

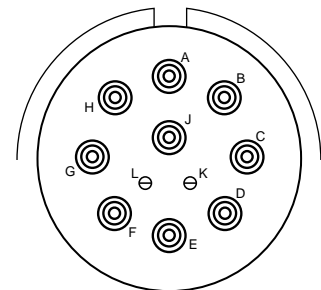

25-11

Auxiliary Power Signal Set



Pin Contact Data for MIL-STD-1760

| Insert Arrangement | Service Rating | Total Contacts | Contact |    |           |            |
|--------------------|----------------|----------------|---------|----|-----------|------------|
|                    |                |                | 20      | 16 | 12 (Coax) | 8 (Twinax) |
| 25-20              | N              | 30             | 10      | 13 | 4         | 3          |

Contacts for 25-20 Pattern

| Shell Size | Arrg. Number | Number of Contacts | Size Contacts                | Service Rating | Contact Location                      | Standard Contacts |                |
|------------|--------------|--------------------|------------------------------|----------------|---------------------------------------|-------------------|----------------|
|            |              |                    |                              |                |                                       | Pin               | Socket         |
| 25         | -20          | 3                  | 8                            | Twinax         | A, H, K                               | M39029/90-529     | M39029/91-530  |
|            |              | 4                  | 12                           | Coax           | 2,3                                   | M39029/28-211     | M39029/75-416  |
|            |              |                    |                              |                | W, 5                                  | M39029/102-558    | M39029/103-559 |
|            |              | 13                 | 16                           | N              | C, D, E, F, J, M, N, P, R, T, U, Y, Z | M39029/58-364     | M39029/56-352  |
| 10         | 20           | N                  | B, G, L, S, V, X, 1, 4, 6, 7 | M39029/58-363  | M39029/56-351                         |                   |                |

| Insert Arrangement | Service Rating | Total Contacts | Contact Size |            |
|--------------------|----------------|----------------|--------------|------------|
|                    |                |                | 20           | 10 (power) |
| 25-11              | N              | 11             | 2            | 9          |

## Applications- Lanyard Release Plug

### HOW TO ORDER - BY MILITARY PART NUMBER FAIL SAFE D38999/31

Ordering procedure for example part number D38999/31WE20PN1 is shown below:

### Easy Steps to build a part number... Military

| 1.                | 2.                | 3.            | 4.                  | 5.                 | 6.            | 7.                        | 8.          |
|-------------------|-------------------|---------------|---------------------|--------------------|---------------|---------------------------|-------------|
| DOD Number Prefix | Spec Sheet Number | Service Class | Lanyard Length Code | Insert Arrangement | Contact Style | Alternate Keying Position | Type Number |
| D38999/           | 31                | W             | E                   | 20                 | P             | N                         | 1           |

#### 1. Select a DOD Number Prefix

|         | Designates                                     |
|---------|--|
| D38999/ | MIL-DTL-38999, Series III Tri-Start Connectors |

#### 2. Specification Sheet Number

|    | Designates   |
|----|--|
| 31 | Designates Lanyard Release Plug for MIL-STD-1760 with pin contacts |

#### 3. Select a Service Class

|   | Designates   |
|---|--|
| F | Electroless nickel plated aluminum, optimum EMI shielding effectiveness –65dB @ 10 GHz specification min., 48 hour salt spray, 200°C |
| W | Corrosion resistant olive drab cadmium plate aluminum, 500 hour extended salt spray, EMI –50dB @ 10 GHz specification min., 175°C    |

#### 4. Select a Lanyard Length Code

| Lanyard Length (in.) ±.236 | Lanyard Length (mm.) ± 6.0 | Lanyard Length Code for Part Number |
|----------------------------|----------------------------|-------------------------------------|
| 6.024                      | 153.0                      | E                                   |
| 6.535                      | 166.0                      | F                                   |
| 7.008                      | 178.0                      | G                                   |
| 7.520                      | 191.0                      | H                                   |
| 7.992                      | 203.0                      | I                                   |
| 8.504                      | 216.0                      | J                                   |
| 9.016                      | 229.0                      | K                                   |
| 9.528                      | 242.0                      | L                                   |

#### 5. Select an Insert Arrangement

Only 11 or 20 are available contact arrangement numbers. See page 40.

#### 6. Contact Style – P & A are Valid Options

|   | Designates  |
|---|---|
| P | Replaces the “no designation” option in the PIN on revision C and earlier revision of the Mil-Spec. |
| A | Designates supplied less contacts.  |

#### 7. Alternate Keying Position

|   | Designates                       |
|---|----------------------------------|
| N | Is required for normal position. |

#### 8. Type Number

Type 1, 2 or 6. See drawings on page 40.

For accessories for lanyard release plugs see page 90.

III  
II  
I  
SJT  
38999

Matrix 2  
26482

Matrix  
Pyle  
83723 III

Release Matrix  
Crimp Rear  
5015

Pyle  
26500

Printed  
Circuit Board

EMI Filter  
Transient

Fiber Optics

High Speed  
Contacts

Options  
Others

## D38999 Type Hybrid Breakaway – Series III Crimp, Metal Shell with Composite Operating Sleeve, And Lower Profile Lanyard Release Plug

38999 III  
SJT I II

26482 Matrix 2

83723 III Matrix Pyle

5015 Crimp Rear Release Matrix

26500 Pyle

Printed Circuit Board

EMI Filter Transient

Fiber Optics

High Speed Contacts

Options Others

**New Hybrid Lanyard Breakaway Fail Safe connector with a composite thermoplastic outer operating sleeve for greater durability.**

This new hybrid breakaway is the breakaway of choice for the Navy F-18 program.

Amphenol's hybrid lanyard design offers greater durability over D38999 aluminum and composite designs because of its ability to handle abuse taken after weapons release. Other advantages include:

- Lower profile compared to full metal breakaway Fail Safe connectors
- Less weight

This Hybrid Breakaway meets the applicable requirements of MIL-DTL-38999/31 including random & sine vibration, ice resistance, fluid immersion and hydrolytic stability tests. (Test reports are available upon request).

Currently the hybrid breakaway is available in shell sizes 25 and 17. It uses standard inserts available for breakaway plugs sizes 25 and 17, and is also available with inserts 25-20 and 25-11 for MIL-STD-1760. Consult Amphenol Aerospace for ordering of the new hybrid breakaway connectors. These hybrid connectors will accommodate the standard backshells for breakaway connectors shown on page 90.



**New Hybrid Lanyard Release Plugs**  
(Metal inside shells and Composite, lower profile outer sleeves)

## Stores Management Type II, Rail Launch Plugs and receptacles that meet MIL-STD-1760

**Amphenol provides a Breakaway Rail Launch connector that is designed for use on aircraft that carry rail launch missiles such as AMRAAM.**

These connectors are designed for blindmating of stores on rail launch applications. They consist of a buffer plug and a missile receptacle that meet the specifications of MIL-STD-1760 Stores Management.

Other features and benefits include:

- Designed to MIL-C-83538 specifications
- Bayonet and push pull coupling
- Use standard MIL-DTL-38999 crimp termination with power, coax and twinax contacts also available
- Buffer provides flame barrier
- Buffers are replaceable

Consult Amphenol Aerospace for more information and ordering.



**Stores Management Type II Rail Launch Connectors**



# HD38999 High Density

## A connector that has the connections...

The HD38999 family of connectors was designed to work with existing mil-specified 38999 shells. To the end users familiar with standard 38999 connectors, this family of high density connectors will look, feel, and perform just like the mil-qualified connectors. Utilizing an existing mil-qualified 39029 size 23 contact and mil-qualified shells, the new system will be, in many cases, a drop-in connector. Even though the HD38999 has 30% more contacts, it still performs to minimum electrical requirements of standard 38999 connectors.



# High Density Interconnects

Goes from 9 to 187 contacts!



- Aluminum
- Composite
- Stainless Steel
- Sealed
- Filtered



For more information e-mail:  
[hd38999info@amphenol-aao.com](mailto:hd38999info@amphenol-aao.com)  
 Specifications, descriptions and illustrations in this literature are as accurate as known at the time of publication, but are subject to change without notice.

Shell Sizes (Front of Pin Insert Shown)

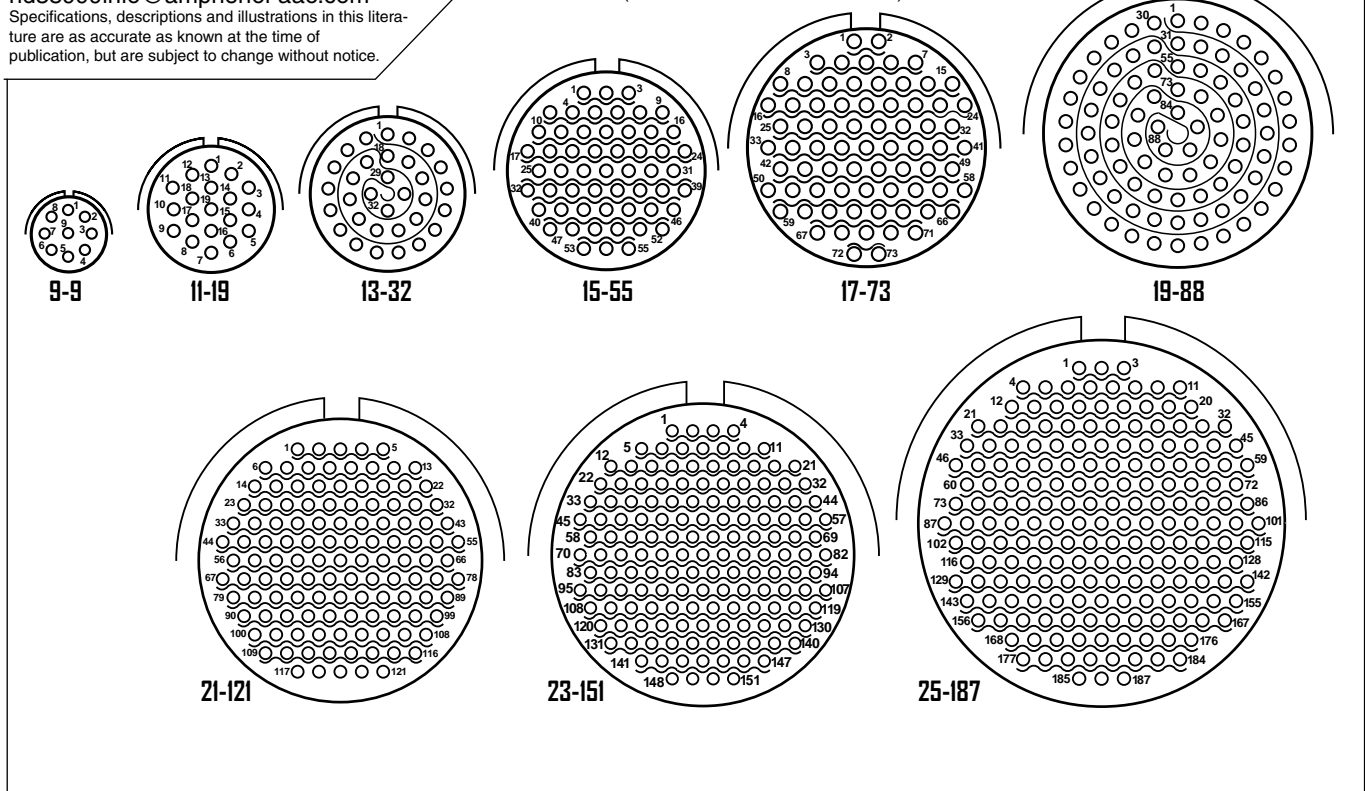

Front of Pin Insert Shown.

|     |                                |
|-----|--------------------------------|
| III | 38999                          |
| II  | 26482 Matrix 2                 |
| I   | 83723 III Matrix Pyle          |
| SJT | 5015 Crimp Rear Release Matrix |
|     | 26500 Pyle                     |
|     | Printed Circuit Board          |
|     | EMI Filter Transient           |
|     | Fiber Optics                   |
|     | High Speed Contacts            |
|     | Options Others                 |



38999

III  
II  
I  
SJT

### CRIMP CONTACT SIZE

SAE AS39029, SIZE 23

### WIRE BARREL RANGES/CURRENT CAPABILITY

|        |          |
|--------|----------|
| 22 AWG | 5.0 AMPS |
| 24 AWG | 3.0 AMPS |
| 26 AWG | 2.0 AMPS |
| 28 AWG | 1.5 AMPS |

### CRIMP BARREL DIAMETER

(Inches) .034-.036

### CRIMP BARREL

Depth (Inches).151-.155

Note: Wire insulation diameter greater than 0.045 inches is too large for the extraction tool to work properly. Connector damage is possible.  
Contact Part Numbers Crimp Tool - Daniels M22520/2-01

Size 23 Sockets 10-597330-735 Positioner - Daniels M22520/2-13 – Pins  
Size 23 Pins 10-597331-735 Daniels M22520/2-16 – Sockets  
Sealing Plugs 10-405996-222 (M27488-22-2) Insertion/Removal Tool - Glenair 809-088

Temperature Range:  
-65C to 175C

Insulation Resistance:  
5000 megohms min. @ 500 VDC 25C

Dielectric Withstanding Voltage:  
1000 VRMS @ Sea level

26482

Matrix 2

83723 III

Matrix Pyle

## Easy Steps to build a part number... HD38999



| 1.             | 2.           | 3.            | 4.                              | 5.           | 6.                  | 7.          |
|----------------|--------------|---------------|---------------------------------|--------------|---------------------|-------------|
| Connector Type | Shell Styles | Service Class | Shell Size – Insert arrangement | Contact Type | Alternate Positions | PCB Options |
| (P)TV          | 06           | RW            | 23-151                          | P            | B                   | (P25)       |

### Step 1. Select a Connector Type

|     | Designates                    |
|-----|-------------------------------|
| TV  | Tri-Start Series Connector    |
| TVP | Back panel mounted receptacle |
| (P) | Potted version                |

### Step 2. Select a Shell Style

|    | Designates            |
|----|-----------------------|
| 00 | Wall mount receptacle |
| 01 | Line receptacle       |
| 06 | Straight plug         |
| 07 | Jam nut receptacle    |

### Step 3. Select a Service Class

|    | Designates   |
|----|--|
| RF | Electroless nickel plated aluminum, optimum EMI shielding effectiveness -65dB @ 10GHz specification min., 48 hour salt spray, 175°C                      |
| RW | Corrosion resistant olive drab cadmium plate aluminum, 500 hour extended salt spray, EMI -50dB @ 10GHz specification min., 175°C                         |
| RK | Corrosion resistant stainless steel, plus 500 hour salt spray resistance, EMI -45 dB @ 10 GHz specification min., 175°C                                  |
| DT | Durmalon plated, alternative to Cadmium. Corrosion resistant, 500 hour extended salt spray, EMI -50dB @ 10GHz specification min. without CR <sup>6</sup> |
| ZN | Zinc-Nickel Alternative to Cadmium corrosion resistant, 500 hour salt spray, Conductive, -65°C to +175°C   |

### Step 4. Select a Shell Size – Insert Arrangement

Shell Sizes are MIL-DTL-38999, Series III, plus newer High Density insert arrangements

| Shell Size | Insert Arrangement | Shell Size | Insert Arrangement |
|------------|--------------------|------------|--------------------|
| 9 – 9      |                    | 19 – 88    |                    |
| 11 – 19    |                    | 21 – 121   |                    |
| 13 – 32    |                    | 23 – 151   |                    |
| 15 – 55    |                    | 25 – 187   |                    |
| 17 – 73    |                    |            |                    |

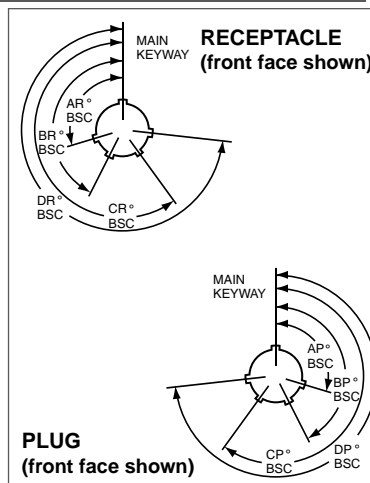

### Step 6. Select an Alternate Position

A, B, C, D, E, blank for normal

| Shell Size     | Key & keyway arrangement identification letter | AR° or AP° BSC | BR° or BP° BSC | CR° or CP° BSC | DR° or DP° BSC |
|----------------|--|----------------|----------------|----------------|----------------|
| 9              | N*   | 105            | 140            | 215            | 265            |
|                | A  | 102            | 132            | 248            | 320            |
|                | B  | 80             | 118            | 230            | 312            |
|                | C  | 35             | 140            | 205            | 275            |
|                | D  | 64             | 155            | 234            | 304            |
| 11, 13, and 15 | E  | 91             | 131            | 197            | 240            |
|                | N*   | 95             | 141            | 208            | 236            |
|                | A  | 113            | 156            | 182            | 292            |
|                | B  | 90             | 145            | 195            | 252            |
|                | C  | 53             | 156            | 220            | 255            |
| 17 and 19      | D  | 119            | 146            | 176            | 298            |
|                | E  | 51             | 141            | 184            | 242            |
|                | N*   | 80             | 142            | 196            | 293            |
|                | A  | 135            | 170            | 200            | 310            |
|                | B  | 49             | 169            | 200            | 244            |
| 21, 23, and 25 | C  | 66             | 140            | 200            | 257            |
|                | D  | 62             | 145            | 180            | 280            |
|                | E  | 79             | 153            | 197            | 272            |
|                | N*   | 80             | 142            | 196            | 293            |
|                | A  | 135            | 170            | 200            | 310            |
|                | B  | 49             | 169            | 200            | 244            |
|                | C  | 66             | 140            | 200            | 257            |
|                | D  | 62             | 145            | 180            | 280            |
|                | E  | 79             | 153            | 197            | 272            |

A plug with a given rotation letter will mate with a receptacle with the same rotation letter. The angles for a given connector are the same whether it contains pins or sockets. Inserts are not rotated in conjunction with the master key/keyway.

### Step 5. Select a Contact Type

|   | Designates      |
|---|-----------------|
| P | Pin contacts    |
| S | Socket contacts |

### Step 7. Select a PCB Contacts

| Pin | Socket | Designates                                    |
|-----|--------|---|
| P1  | S1     | PCB tail stickout .100" nominal +/- .040 inch |
| P15 | S15    | PCB tail stickout .150" nominal +/- .040 inch |
| P2  | S2     | PCB tail stickout .200" nominal +/- .040 inch |
| P25 | S25    | PCB tail stickout .250" nominal +/- .040 inch |

5015

Crimp Rear Release Matrix

26500

Pyle

Printed

Circuit Board

EMI Filter

Transient

Fiber Optics

High Speed

Contacts

Options

Others



Amphenol® LJT and JT Series subminiature cylindrical connectors are qualified to MIL-DTL-38999\*, Series I and II respectively. These connectors were developed to meet the needs of the aerospace industry, and provided the impetus for development of the MIL-C-38999 specifications, which has been superseded by MIL-DTL-38999. Meeting or exceeding MIL-DTL-38999 requirements, Amphenol® JT/LJT connectors feature:

- **Lightweight, Space Saving Design**
- **Contact Protection** - 100% scoop-proof LJT design prevents bent pins and short circuits during mating
- **Quick Positive Coupling** - 3 point bayonet lock system
- **Mismating Eliminated** - with 5 key/keyway design
- **Error Proof Alternate Positioning** - insured by different key/keyway locations
- **EMI Shielding** - grounding fingers standard in LJT Series; optional in JT Series
- **Nine Shell Sizes and a Variety of Shell Styles**
- **Contact Options** - size 8, 10, 12, 16, 20, 22M and 22D Crimp, Solder, PCB, Wire wrap, Coax, Twinax, Triax, Thermocouple, Fiber Optic and Filter
- **Fixed Solder Contacts** - Amphenol MIL-DTL-38999 Series I LJT and II JT, are available in solder versions as both Commercial and Military qualified to MIL-DTL-27599
- **Hermetic** - air leakage limited to  $1 \times 10^{-7} \text{ cm}^3$  per second optional
- **“Breakaway” Lanyard Release Style** - available in LJT plugs. Provides quick disconnect of the connector plug and receptacle with axial pull on the lanyard. See pages 78-80.
- **Inventory Support Commonality** - uses standard MIL-DTL-38999 contacts, insert arrangements and application tools.
- **RoHS Compliant Product Available** - Consult Amphenol Aerospace Operations.



Where proof of high reliability and lot control is required, MS approved equivalents to most proprietary JT and LJT connectors are available.

\* MIL-DTL-38999 Series I supersedes MIL-C-38999 Series I.  
MIL-DTL-38999 Series II supersedes MIL-C-38999 Series II.

### Components

Shell components are impact extruded or machined bar stock aluminum. Standard plating on shell components is cadmium over nickel. Many finishes are optional (see “Specifications” page 16). Hermetic seal receptacles are available in carbon steel or stainless steel shells. Dependable 5 key/keyway polarization with bayonet lock coupling is incorporated to aid and assure positive mating.

Insert material is a rigid dielectric with excellent electrical characteristics, providing durable protection for molded-in solder type contacts. Contrasting letter or number designations are used on insert faces.

A fluorinated silicone interfacial seal wafer is featured on the mating face of “crimp type pin” inserts. This assures complete electrical isolation of pins when connector halves are mated. In addition, a main joint gasket is installed in the receptacle for moisture sealing between connector halves. Both features are also available for hermetic receptacles.

### Contacts

Maximum design flexibility is built into the JT/LJT Series, with a minimum of 2 to a maximum of 128 circuits per connector in a wide variety of contact arrangements. Contacts are available in sizes 8, 10, 12, 16, 20, 22, 22D and 22M with standard 50 micro inch minimum gold plating (100 micro inches optional). All socket contacts are probe proof. Crimp type rear removable contacts are featured in JT-R and LJT-R connectors. Solder termination contacts are also available, as well as PCB, wire wrap, thermocouple, fiber optic, coaxial, triaxial and twinax contact options.

### Optional Features

High temperature capability of 392°F is available only in JTS or LJTS crimp type connectors. High temperature versions feature gold plated contacts, high temperature shell plating, stainless steel coupling nut spring, and epoxy inserts/fluorinated silicone grommet combination. Standard temperature capability for both solder and crimp is 302°F.

The JTN or LJTN type connectors are available for  $\text{N}_2\text{O}_4$  resistance provided they are mated, and un-grommated rear faces are suitably protected. For complete listing and definition of connector types, shell styles and service classes, see How to Order, page 46. For information on Fail-Safe Lanyard Release style plugs, see pages 78–80.

38999  
III  
II  
I  
SJT

26482  
Matrix 2

83723 III  
Matrix  
Pyle

5015  
Crimp Rear  
Release Matrix

26500 Pyle

Printed  
Circuit Board

EMI Filter  
Transient

Fiber Optics

High Speed  
Contacts

Options  
Others

### How to Order (Commercial)

## Easy Steps to build a commercial part number... Series I and II Commercial

- 1.
- 2.
- 3.
- 4.
- 5.
- 6.
- 7.

| Connector Type<br>Series I |    | Shell Style | Service Class | Shell Size-<br>Insert Arrangement | Contact Type | Alternate Position | Strain Relief/Finish<br>Variation Suffix |       |
|----------------------------|----|-------------|---------------|-----------------------------------|--------------|--------------------|--|-------|
| LJT                        | JT | 00          | RT            | 9-35                              | P            | B                  | SR                                       | (014) |

### Step 1. Select a Connector Type

- 1.
- 2.
- 3.
- 4.
- 5.
- 6.
- 7.

| Connector Type | Shell Style | Service Class | Shell Size-<br>Insert Arrg. | Contact Type | Alternate Position | Special Variations |
|----------------|-------------|---------------|-----------------------------|--------------|--------------------|--------------------|
| JT             |             |               |                             |              |                    |                    |

| Series I | Series II | Designates                                       |
|----------|-----------|--|
|          | JT        | Standard Junior Tri-Lock                         |
| LJT      |           | Long Junior Tri-Lock                             |
| LJTS     | JTS       | High temperature connector                       |
| LJTN     | JTN       | Chemical and fuel resistant                      |
|          | JTL       | Miniature mounting dimensions                    |
|          | JTLN      | Miniature mounting dimensions—Chemical resistant |
|          | JTLS      | Miniature mounting dimensions— High temperature  |
| LJTPQ    | JTPQ      | Back panel mounted wall mounting receptacle      |
| LJTP     | JTP       | Back panel mounted box mounting receptacle       |
| LJTPN    | JTPN      | Back panel mounted—Chemical resistant            |
| LJTPS    | JTPS      | Back panel mounted—High temperature              |
|          | JTG       | Plug with grounding fingers*                     |
|          | JTNG      | Plug with grounding fingers* —Chemical resistant |

\*Grounding fingers standard on all LJT plugs

### Step 2. Select a Shell Style... Series I & II

- 1.
- 2.
- 3.
- 4.
- 5.
- 6.
- 7.

| Connector Type | Shell Style | Service Class | Shell Size-<br>Insert Arrg. | Contact Type | Alternate Position | Special Variations |
|----------------|-------------|---------------|-----------------------------|--------------|--------------------|--------------------|
|                | 00          |               |                             |              |                    |                    |

Lanyard Release Connector (See pages 78-80 for ordering)

|    | Designates  |
|----|---|
| 00 | Wall mount receptacle   |
| 01 | Line mount receptacle   |
| 02 | Box mount receptacle  |
| 06 | Straight plug   |
| 07 | Jam nut receptacle  |
| 08 | 90 degree plug  |
| I  | Solder mount receptacle- hermetic   |
| 88 | Fail safe lanyard release plug with corrosion resistant olive drab cadmium plate over nickel shells |
| 91 | Fail safe lanyard release plug with electroless nickel plated aluminum shells.                      |

#### Series I LJT

#### Series II JT



Wall Mounting Receptacle



Wall Mounting Receptacle



Line Receptacle



Box Mounting Receptacle



Jam Nut Receptacle



Straight Plug



Straight Plug



Jam Nut Receptacle



Solder Mounting Receptacle



90° Plug

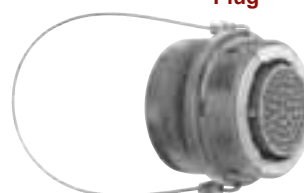

Lanyard Release Plug



Solder Mounting Receptacle

## How to Order (Commercial)

### Step 3. Select a Service Class

| 1.             | 2.          | 3.            | 4.                      | 5.           | 6.                 | 7.                 |
|----------------|-------------|---------------|-------------------------|--------------|--------------------|--------------------|
| Connector Type | Shell Style | Service Class | Shell Size-Insert Arrg. | Contact Type | Alternate Position | Special Variations |
|                |             | <b>RX</b>     |                         |              |                    |                    |

| Commercial    | Solder Contacts/Connectors  |
|---------------|---|
| <b>P</b>      | Potting applications: These connectors are supplied with a potting boot. All shells are designed with integral features to retain potting boots.                            |
| <b>A</b>      | General Applications  |
| <b>A (SR)</b> | Threaded rear design with strain relief†  |
| <b>C</b>      | Pressurized applications  |
| <b>C (SR)</b> | Threaded rear design with strain relief.†   |
| <b>E</b>      | Box mount and thru-bulkhead only with no backend threads.   |
| <b>H</b>      | Hermetic applications- Fused compression glass sealed inserts. Leadage rate less than .01 micron cu. ft./hr. (1 x 10 <sup>-7</sup> cc/sec.) at 15 psi differential.         |
| <b>Y</b>      | Same as "H" with interfacial seal.  |
| <b>T</b>      | MS27599A applications-general duty, pressurized (receptacle only)   |
| Commercial    | Crimp Contacts/Connectors   |
| <b>RP</b>     | Potting crimp applications. Supplied with spacer grommet and potting boot.††  |
| <b>RE</b>     | Environmental crimp applications. Supplied with a grommet and compression nut.† Can be supplied with strain relief integral with compression nut "RE(SR)". (JT Series only) |
| <b>RGF</b>    | Electroless nickel plated ground plane aluminum, 200°C  |
| <b>RGW</b>    | Olive drab cadmium plated ground plane aluminum, 175°C  |
| <b>RT</b>     | Environmental applications. Supplied without rear accessories. Design provides serrations on rear threads of shells.  |

† Not applicable to box mounting style or LJT Series I.  
 †† Not applicable to box mounting style.

### Step 4. Select a Shell Size & Insert Arrangement see page 4-7

Shell Size & Insert Arrangements are on pages 4-7.  
 First number represents Shell Size,  
 second number is the Insert Arrangement.

| 1.             | 2.          | 3.            | 4.                      | 5.           | 6.                 | 7.                 |
|----------------|-------------|---------------|-------------------------|--------------|--------------------|--------------------|
| Connector Type | Shell Style | Service Class | Shell Size-Insert Arrg. | Contact Type | Alternate Position | Special Variations |
|                |             |               | <b>22-2</b>             |              |                    |                    |

### Step 5. Select a Contact Type

| 1.             | 2.          | 3.            | 4.                      | 5.           | 6.                 | 7.                 |
|----------------|-------------|---------------|-------------------------|--------------|--------------------|--------------------|
| Connector Type | Shell Style | Service Class | Shell Size-Insert Arrg. | Contact Type | Alternate Position | Special Variations |
|                |             |               |                         | <b>P</b>     |                    |                    |

|          | Designates      |
|----------|-----------------|
| <b>P</b> | Pin Contacts    |
| <b>S</b> | Socket Contacts |

III  
II  
I  
SJT  
**38999**

Matrix 2  
**26482**

Matrix Pyle  
**83723 III**

Crimp Rear Release Matrix  
**5015**

Pyle  
**26500**

Printed Circuit Board

EMI Filter Transient

Fiber Optics

High Speed Contacts

Options Others

- 38999 III
- SJT I II
- 26482 Matrix 2
- 83723 III Pyle
- 5015 Crimp Rear Release Matrix
- 26500 Pyle
- Printed Circuit Board
- EMI Filter Transient
- Fiber Optics
- High Speed Contacts
- Options Others

|                |             |               |                         |              |                    |                    |
|----------------|-------------|---------------|-------------------------|--------------|--------------------|--------------------|
| 1.             | 2.          | 3.            | 4.                      | 5.           | 6.                 | 7.                 |
| Connector Type | Shell Style | Service Class | Shell Size Insert Arrg. | Contact Type | Alternate Position | Special Variations |
|                |             |               |                         |              | A                  |                    |

**Step 6. Select an Alternate Keying Position**

“A” designates Alternate keying connector assembly. Other basic alternate keys are “B”, “C” and “D”. No letter required for normal rotation (no rotation) position.

A plug with a given rotation letter will mate with a receptacle with the same rotation letter. The AB angle for a given connector is the same whether it contains pins or sockets. Only the master key/keyway rotates in the shell, and the minor keys are fixed.

AB angles shown are viewed from the front face of the connector, a receptacle is shown below. The angles for the plug are exactly the same except the direction of rotation is opposite of that shown for the receptacle.

The “N” designation is not referenced in part number, it is omitted.

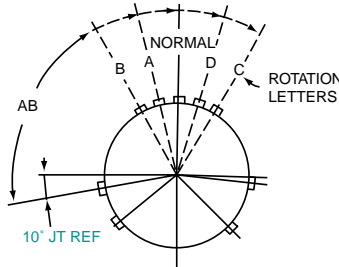

RELATIVE POSSIBLE POSITION OF ROTATED MASTER KEYWAY (front face of receptacle shown)

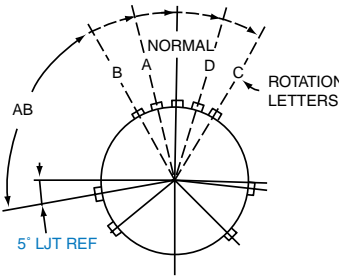

RELATIVE POSSIBLE POSITION OF ROTATED MASTER KEYWAY (front face of receptacle shown)

**JT Key/Keyway Rotation**

| AB ANGLE OF ROTATION (Degrees) |        |     |     |      |      |
|--------------------------------|--------|-----|-----|------|------|
| Shell Size                     | Normal | A   | B   | C    | D    |
| 8                              | 100°   | 82° | -   | -    | 118° |
| 10                             | 100°   | 86° | 72° | 128° | 114° |
| 12                             | 100°   | 80° | 68° | 132° | 120° |
| 14                             | 100°   | 79° | 66° | 134° | 121° |
| 16                             | 100°   | 82° | 70° | 130° | 118° |
| 18                             | 100°   | 82° | 70° | 130° | 118° |
| 20                             | 100°   | 82° | 70° | 130° | 118° |
| 22                             | 100°   | 85° | 74° | 126° | 115° |
| 24                             | 100°   | 85° | 74° | 126° | 115° |

**LJT Key/Keyway Rotation**

| AB ANGLE OF ROTATION (Degrees) |        |     |     |      |      |
|--------------------------------|--------|-----|-----|------|------|
| Shell Size                     | Normal | A   | B   | C    | D    |
| 9                              | 95°    | 77° | -   | -    | 113° |
| 11                             | 95°    | 81° | 67° | 123° | 109° |
| 13                             | 95°    | 75° | 63° | 127° | 115° |
| 15                             | 95°    | 74° | 61° | 129° | 116° |
| 17                             | 95°    | 77° | 65° | 125° | 113° |
| 19                             | 95°    | 77° | 65° | 125° | 113° |
| 21                             | 95°    | 77° | 65° | 125° | 113° |
| 23                             | 95°    | 80° | 69° | 121° | 110° |
| 25                             | 95°    | 80° | 69° | 121° | 110° |

|                |             |               |                         |              |                    |                    |
|----------------|-------------|---------------|-------------------------|--------------|--------------------|--------------------|
| 1.             | 2.          | 3.            | 4.                      | 5.           | 6.                 | 7.                 |
| Connector Type | Shell Style | Service Class | Shell Size-Insert Arrg. | Contact Type | Alternate Position | Special Variations |
|                |             |               |                         |              |                    | ( )                |

**Step 7. Select a Strain Relief Option or Finish Variation Suffix**

Strain Relief Options: “SR” designates a strain relief clamp. Strain reliefs are available only on Service Class “A”, “C” and “RE” (see step 3. Service Class)

Finish Variation Suffix: See finish variations available in table to your right.

| Finish                                      | Military Finish Data | Finish Suffix | Finish Plus “SR” Suffix |
|---|----------------------|---------------|-------------------------|
| Cadmium plated nickel base 175° C           | A                    |               | (SR)                    |
| Olive drab cadmium plate nickel base 175° C | B                    | (014)         | (386)                   |
| Electroless nickel 200° C                   | F                    | (023)         | (424)                   |
| Electroless nickel, space compatible 200° C |                      | (453)         | (467)                   |
| Anodic coating (Alumilite) 200° C           | C                    | (005)         | (300)                   |
| Chromate treated (Iridite 14-2) 125° C      |                      | (011)         | (344)                   |
| Passivated steel 200° C                     | E                    | -             | -                       |
| Nickel-PTFE 175° C                          |                      | (038)         |                         |



## How to Order (Commercial)

### Easy Steps to build a Military part number... Series I and II

### Military

- 1.
- 2.
- 3.
- 4.
- 5.
- 6.
- 7.

| MS Number | Service Class | Shell Size | Finish | Insert Arrangement | Contact Style (P or S) | Alternate Keying Position |
|-----------|---------------|------------|--------|--------------------|------------------------|---------------------------|
| MS27473   | E             | 14         | A      | 18                 | P                      | A                         |

#### Step 1. Choose your Military Connector Type

| 1. MS Number | 2. Service Class | 3. Shell Size | 4. Finish | 5. Insert Arrangement | 6. Contact Style (P or S) | 7. Alternate Position |
|--------------|------------------|---------------|-----------|-----------------------|---------------------------|-----------------------|
| MS27473      |                  |               |           |                       |                           |                       |

#### Series II JT

|         | Designates   |
|---------|--|
| MS27472 | Crimp Wall Mount Receptacle                                    |
| MS27497 | Crimp Wall Mount Receptacle Back Panel Mounting                |
| MS27499 | Crimp Box Mounting Receptacle                                  |
| MS27513 | Crimp Box Mounting Receptacle with grommet and compression nut |
| MS27508 | Crimp Box Mounting Receptacle (Back Panel Mounting)            |
| MS27473 | Crimp Straight Plug  |
| MS27484 | Crimp Straight Plug with Grounding Fingers                     |
| MS27474 | Crimp Jam Nut Receptacle                                       |
| MS27500 | Crimp 90° plug   |
| MS27475 | Hermetic Wall Mounting Receptacle                              |
| MS27476 | Hermetic Box Mounting Receptacle                               |
| MS27477 | Hermetic Jam Nut Receptacle                                    |
| MS27478 | Hermetic Solder Mounting Receptacle                            |
| MS27334 | Solder Wall Mount Receptacle                                   |
| MS27335 | Solder Box Mounting Receptacle                                 |
| MS27336 | Solder Straight Plug   |
| MS27337 | Solder Jam Mounting Receptacle                                 |

#### Series I LJT

|         | Designates  |
|---------|---|
| MS27466 | Crimp Wall Mount Receptacle                         |
| MS27656 | Crimp Wall Mount Receptacle Back Panel Mounting     |
| MS27496 | Crimp Box Mounting Receptacle                       |
| MS27505 | Crimp Box Mounting Receptacle (Back Panel Mounting) |
| MS27467 | Crimp Straight Plug                                 |
| MS27468 | Crimp Jam Nut Receptacle                            |
| MS27469 | Hermetic Wall Mounting Receptacle                   |
| MS27470 | Hermetic Jam Nut Receptacle                         |
| MS27471 | Hermetic Solder Mounting Receptacle                 |
| MS20026 | Solder Wall Mounting Receptacle                     |
| MS20027 | Solder Line Receptacle                              |
| MS20028 | Solder Straight Plug                                |
| MS20029 | Solder Jam Nut Receptacle                           |

#### Step 2. Select a Military Service Class

| 1. MS Number | 2. Service Class | 3. Shell Size | 4. Finish | 5. Insert Arrangement | 6. Contact Style (P or S) | 7. Alternate Position |
|--------------|------------------|---------------|-----------|-----------------------|---------------------------|-----------------------|
|              | E                |               |           |                       |                           |                       |

| Military | Service Class   |
|----------|---|
| E        | Environmental crimp applications. Supplied with a grommet and compression nut. † Can be supplied with strain relief integral with compression nut "RE(SR)". (JT Series only). Box Mount versions using spacer grommets are not environmental. |
| P        | Potting crimp applications. Supplied with spacer grommet and potting boot. ††   |
| T        | Environmental applications. Supplied without rear accessories. Design provides serrations on rear threads of shells. (MS27599 applications)- General duty-pressurized (receptacles only)  |
| Y        | Hermetically interfacial seal   |

† Not applicable to box mounting style or LJT Series I.

†† Not applicable to box mounting style.

III
38999

II
I

SJT

Matrix 2
26482

Matrix
83723 III

Pyle
5015

Crimp Rear Release Matrix
26500 Pyle

Printed Circuit Board
EM1 Filter

Transient
Fiber Optics

High Speed Contacts
Options

Others

38999  
SJT  
I  
II  
III

26482  
Matrix 2

83723 III  
Matrix  
Pyle

5015  
Crimp Rear  
Release Matrix

26500 Pyle

Printed  
Circuit Board

EMI Filter  
Transient

Fiber Optics

High Speed  
Contacts

Options  
Others

**Step 3 & 5.** Select a Shell Size and Insert Arrangement from Pages 4-7

| 1.        | 2.            | 3.         | 4.        | 5.                 | 6.                     | 7.                 |
|-----------|---------------|------------|-----------|--------------------|------------------------|--------------------|
| MS Number | Service Class | Shell Size | 4. Finish | Insert Arrangement | Contact Style (P or S) | Alternate Position |
|           |               | 14         |           | 18                 |                        |                    |

Shell Size & Insert Arrangement are on pages 4-7. First number represents Shell Size, second number is the Insert Arrangement. Place Shell Size in box 3 and Insert Arrangement in box 5.

**Step 4.** Select a Military Finish

| 1.        | 2.            | 3.         | 4.     | 5.                 | 6.                     | 7.                 |
|-----------|---------------|------------|--------|--------------------|------------------------|--------------------|
| MS Number | Service Class | Shell Size | Finish | Insert Arrangement | Contact Style (P or S) | Alternate Position |
|           |               |            | A      |                    |                        |                    |

| Finish                                      | Military Finish Data | Finish Suffix | Finish Plus "SR" Suffix |
|---|----------------------|---------------|-------------------------|
| Cadmium plated nickel base 175° C           | A                    |               | (SR)                    |
| Olive drab cadmium plate nickel base 175° C | B                    | (014)         | (386)                   |
| Electroless nickel 200° C                   | F                    | (023)         | (424)                   |
| Electroless nickel, space compatible 200° C |                      | (453)         | (467)                   |
| Anodic coating (Alumilite) 200° C           | C                    | (005)         | (300)                   |
| Chromate treated (Iridite 14-2) 125° C      |                      | (011)         | (344)                   |
| Passivated steel 200° C                     | E                    | -             | -                       |
| Nickel-PTFE 175° C                          |                      | (038)         |                         |

**Step 6.** Select a Military Contact Type

|   | Designates      |
|---|-----------------|
| P | Pin Contacts    |
| S | Socket Contacts |

| 1.        | 2.            | 3.         | 4.     | 5.                 | 6.                     | 7.                 |
|-----------|---------------|------------|--------|--------------------|------------------------|--------------------|
| MS Number | Service Class | Shell Size | Finish | Insert Arrangement | Contact Style (P or S) | Alternate Position |
|           |               |            |        |                    | P                      |                    |

**Step 7.** Select an Alternate Keying Position

See pg 48 for information, No letter required for normal position

| 1.        | 2.            | 3.         | 4.     | 5.                 | 6.                     | 7.                 |
|-----------|---------------|------------|--------|--------------------|------------------------|--------------------|
| MS Number | Service Class | Shell Size | Finish | Insert Arrangement | Contact Style (P or S) | Alternate Position |
|           |               |            |        |                    |                        | A                  |

# Amphenol MIL-DTL-38999, Series II, JT



## TABLE OF CONTENTS

### Combined MIL-DTL-38999 Series I, II, III

- Shell Size & Insert Arrangements Availability . . . . . 4-7
- Insert Arrangement Drawings . . . . . 8-14
- Specifications - Contact Ratings, Service Ratings, Finish Data . . . . . 15, 16

### MIL-DTL-38999, Series II JT and Series I LJT

- Features and Benefits . . . . . 45
- How to Order (Commercial). . . . . 46-48
- How to Order (Military). . . . . 49, 50

### JT Shell Styles:

- Table of Contents . . . . . 51
- Crimp Wall Mounting Receptacle JT00R (MS27472) . . . . . 52
- Crimp Wall Mounting Receptacle for Back Panel Mounting JTPQ00R (MS27497) 53
- Crimp Line Receptacle JT01R. . . . . 54
- Crimp Box Mounting Receptacles JT02RE (MS27499), JT02RE(053) (MS27513) 55
- Crimp Box Mounting Receptacle for Back Panel Mounting JTP02R (MS27508) 56
- Crimp Straight Plug JT06R (MS27473) . . . . . 57
- Crimp Straight Plug with Grounding Fingers JTG06R (MS27484) . . . . . 58
- Crimp Jam Nut Receptacle JT07R (MS27474) . . . . . 59
- Crimp Jam Nut Receptacle (Miniature Jam Nut Mounting Dimensions) JTL07R 60
- Crimp 90° Plug JT08R (MS27500) . . . . . 61
- Hermetic Wall Mounting Receptacle JT00 (MS27475),  
Hermetic Box Mounting Receptacle JT02 (MS27476) . . . . . 62
- Hermetic Jam Nut Receptacle JT07 (MS27477),  
Hermetic Solder Mounting Receptacle JTI (MS27478) . . . . . 63
- Solder Wall Mounting Receptacle JT00 (MS27334),  
Solder Box Mounting Receptacle JT02 (MS27335) . . . . . 64
- Solder Straight Plug JT06 (MS27336),  
Solder Straight Plug with Grounding Ring JTG06A . . . . . 65
- Solder Jam Nut Receptacle JT07 (MS27337),  
Solder 90° Plug JT08 . . . . . 66
- Accessories, Contacts, and Tools see pages . . . . . 89-108



## MIL-DTL-38999 Series II Typical Markets:

- Military & Commercial Aviation
- Military Vehicles
- Missiles & Ordnance
- C4ISR



- 38999 III
- SJT I II
- 26482 Matrix 2
- 83723 III Pyle Matrix
- 5015 Crimp Rear Release Matrix
- 26500 Pyle
- Printed Circuit Board
- EMI Filter Transient
- Fiber Optics
- High Speed Contacts
- Options Others

**PART #** Part number reference. To complete, see how to order pages 46-50.

**Commercial**

| Connector Type | Shell Style | Service Class | Shell Size & Insert Arrg | Contact Type | Alternate Position | Special Variations |
|----------------|-------------|---------------|--------------------------|--------------|--------------------|--------------------|
| JT/JTS/JTN     | 00          | RT            | 22-2                     | P            | A                  | (XXX)              |

**Military**

| MS Number | Service Class | Shell Size | Finish | Insert Arrg | Contact Style (P or S) | Alternate Position |
|-----------|---------------|------------|--------|-------------|------------------------|--------------------|
| MS27472   | E             | 14         | A      | 18          | P                      | A                  |
| MS27479   | E             | 14         | A      | 18          | P                      | A                  |

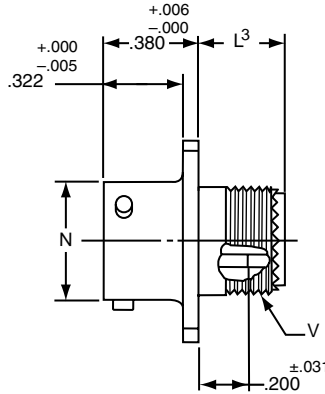
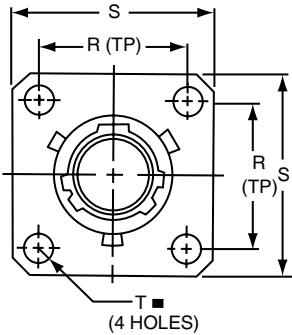

- \* JT00RT-XX-XXX (MS27472T)
- \*\* JTS00RT-XX-XXX (MS27479T)
- \*\*\* JTN00RT-XX-XXX

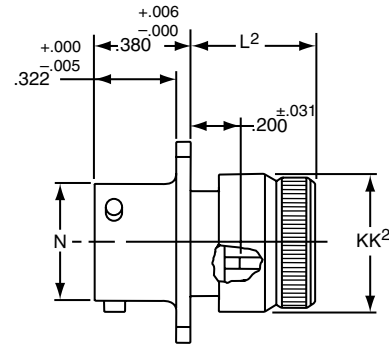

- \* JT00RE-XX-XXX (MS27472E)
- \*\* JTS00RE-XX-XXX (MS27479E)
- \*\*\* JTN00RE-XX-XXX

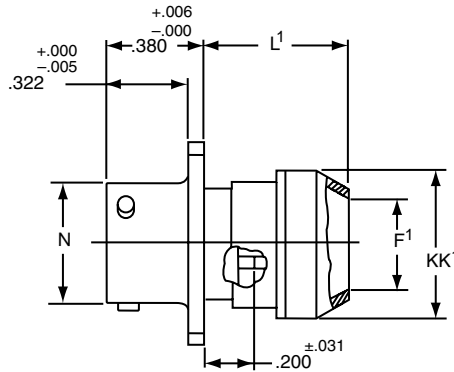

- \* JT00RP-XX-XXX (MS27472P)
- \*\* JTS00RP-XX-XXX
- \*\*\* JTN00RP-XX-XXX

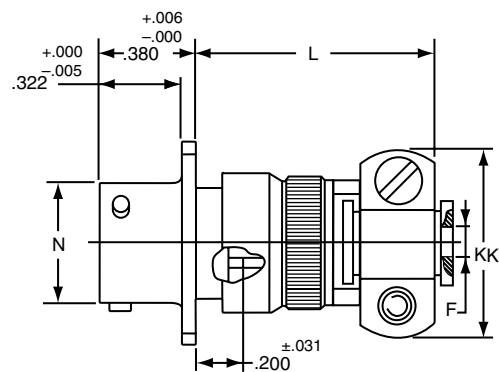

- \* JT00RE-XX-XXX (SR)
- \*\* JTS00RE-XX-XXX (SR)
- \*\*\* JTN00RE-XX-XXX (SR)

⊕ .005 DIA ⊕

- \* Standard Junior Tri-Lock
- \*\* High temperature version
- \*\*\* Clear iridite finish (gold color), N<sub>2</sub>O<sub>4</sub> resistant

| Shell Size | F Dia. +.010 - .025 | F <sup>1</sup> Dia. ±.010 | L Max. | L <sup>1</sup> Max. | L <sup>2</sup> Max. | L <sup>3</sup> Max. | N +.001 - .005 | R (TP) | S ±.016 | T ±.005 | V Thread UNEF Class 2A (Plated) | KK Max. | KK <sup>1</sup> Dia. Max. | KK <sup>2</sup> Dia. Max. |
|------------|---------------------|---------------------------|--------|---------------------|---------------------|---------------------|----------------|--------|---------|---------|---------------------------------|---------|---------------------------|---------------------------|
| 8          | .125                | .444                      | 1.094  | .609                | .547                | .500                | .473           | .594   | .812    | .120    | .4375-28                        | .812    | .625                      | .578                      |
| 10         | .188                | .558                      | 1.094  | .609                | .547                | .500                | .590           | .719   | .938    | .120    | .5625-24                        | .875    | .750                      | .703                      |
| 12         | .312                | .683                      | 1.094  | .609                | .547                | .500                | .750           | .812   | 1.031   | .120    | .6875-24                        | 1.000   | .875                      | .828                      |
| 14         | .375                | .808                      | 1.344  | .609                | .547                | .500                | .875           | .906   | 1.125   | .120    | .8125-20                        | 1.125   | 1.000                     | .953                      |
| 16         | .500                | .909                      | 1.344  | .609                | .547                | .500                | 1.000          | .969   | 1.219   | .120    | .9375-20                        | 1.188   | 1.125                     | 1.078                     |
| 18         | .625                | 1.034                     | 1.344  | .609                | .547                | .500                | 1.125          | 1.062  | 1.312   | .120    | 1.0625-18                       | 1.438   | 1.250                     | 1.203                     |
| 20         | .625                | 1.159                     | 1.344  | .609                | .547                | .500                | 1.250          | 1.156  | 1.438   | .120    | 1.1875-18                       | 1.438   | 1.375                     | 1.328                     |
| 22         | .750                | 1.284                     | 1.469  | .609                | .547                | .500                | 1.375          | 1.250  | 1.562   | .120    | 1.3125-18                       | 1.625   | 1.500                     | 1.453                     |
| 24         | .800                | 1.409                     | 1.469  | .688                | .547                | .500                | 1.500          | 1.375  | 1.688   | .147    | 1.4375-18                       | 1.719   | 1.625                     | 1.578                     |

All dimensions for reference only.

# JTPQ00R (MS27497) Series II – Crimp

## Wall Mounting Receptacle

(Back Panel Mounting)

**PART #** Part number reference. To complete, see how to order pages 46-50.  
**Commercial**

| Connector Type | Shell Style | Service Class | Shell Size & Insert Arrg | Contact Type | Alternate Position | Special Variations |
|----------------|-------------|---------------|--------------------------|--------------|--------------------|--------------------|
| JTPQ/JTPSQ     | 00          | RT            | 22-2                     | P            | A                  | (XXX)              |

**Military**

| MS Number | Service Class | Shell Size | Finish | Insert Arrg | Contact Style (P or S) | Alternate Position |
|-----------|---------------|------------|--------|-------------|------------------------|--------------------|
| MS27497   | E             | 14         | A      | 18          | P                      | A                  |

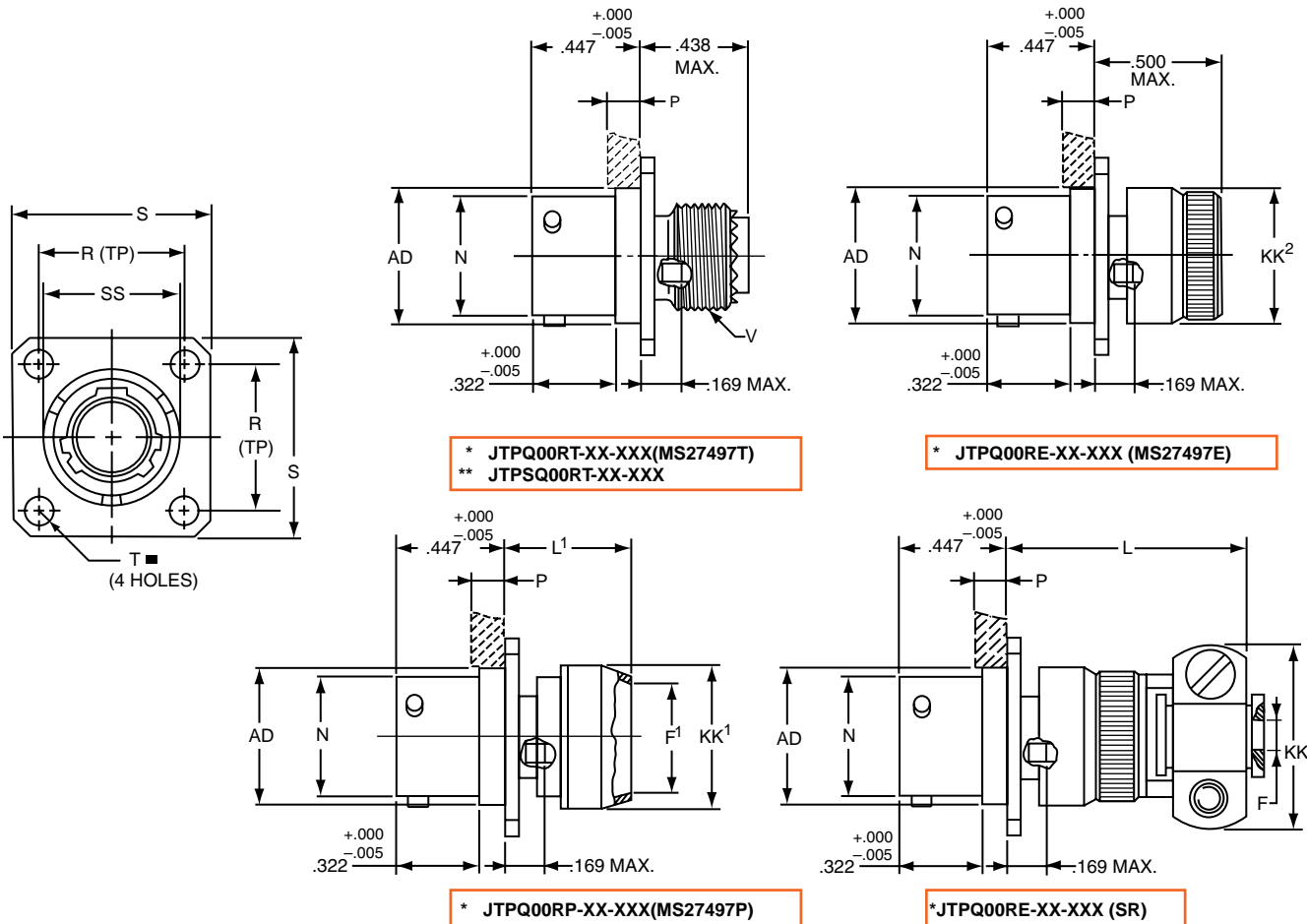

⊕ .005 DIA (M)

\* Standard Junior Tri-Lock

\*\* High temperature version

| Shell Size | F Dia. +.010 - .025 | F' Dia. ±.010 | L Max. | L' Max. | N +.001 - .005 | P Max. Panel Thickness | R (TP) | S ±.016 | T ±.005 | V Thread UNEF Class 2A (Plated) | AD Dia. ±.005 | KK Max. | KK' Dia. Max. | KK² Dia. Max. | SS Dia. +.000 - .016 |
|------------|---------------------|---------------|--------|---------|----------------|------------------------|--------|---------|---------|---------------------------------|---------------|---------|---------------|---------------|----------------------|
| 8          | .125                | .444          | 1.140  | .468    | .473           | .142                   | .594   | .812    | .120    | .4375-28                        | .516          | .781    | .625          | .578          | .563                 |
| 10         | .188                | .558          | 1.140  | .468    | .590           | .142                   | .719   | .938    | .120    | .5625-24                        | .633          | .844    | .750          | .703          | .680                 |
| 12         | .312                | .683          | 1.140  | .468    | .750           | .142                   | .812   | 1.031   | .120    | .6875-24                        | .802          | .969    | .875          | .828          | .859                 |
| 14         | .375                | .808          | 1.375  | .468    | .875           | .142                   | .906   | 1.125   | .120    | .8125-20                        | .927          | 1.094   | 1.000         | .953          | .984                 |
| 16         | .500                | .909          | 1.375  | .468    | 1.000          | .142                   | .969   | 1.219   | .120    | .9375-20                        | 1.052         | 1.154   | 1.125         | 1.078         | 1.108                |
| 18         | .625                | 1.034         | 1.375  | .468    | 1.125          | .142                   | 1.062  | 1.312   | .120    | 1.0625-18                       | 1.177         | 1.406   | 1.250         | 1.203         | 1.233                |
| 20         | .625                | 1.159         | 1.375  | .468    | 1.250          | .142                   | 1.156  | 1.438   | .120    | 1.1875-18                       | 1.302         | 1.406   | 1.375         | 1.328         | 1.358                |
| 22         | .750                | 1.284         | 1.516  | .468    | 1.375          | .142                   | 1.250  | 1.562   | .120    | 1.3125-18                       | 1.427         | 1.594   | 1.500         | 1.453         | 1.483                |
| 24         | .800                | 1.409         | 1.500  | .540    | 1.500          | .142                   | 1.375  | 1.688   | .147    | 1.4375-18                       | 1.552         | 1.688   | 1.625         | 1.578         | 1.610                |

All dimensions for reference only.

38999  
SJT

26482  
Matrix 2

83723 III  
Matrix Pyle

5015  
Crimp Rear Release Matrix

26500 Pyle

Printed  
Circuit Board

EMI Filter  
Transient

Fiber Optics

High Speed  
Contacts

Options  
Others



- 38999 III
- SJT I II
- 26482 Matrix 2
- 83723 III Pyle Matrix
- 5015 Crimp Rear Release Matrix
- 26500 Pyle
- Printed Circuit Board
- EMI Filter Transient
- Fiber Optics
- High Speed Contacts
- Options Others

**PART #** Part number reference. To complete, see how to order pages 46-50.  
**Commercial**

| Connector Type | Shell Style | Service Class | Shell Size & Insert Arrg | Contact Type | Alternate Position | Special Variations |
|----------------|-------------|---------------|--------------------------|--------------|--------------------|--------------------|
| JT/JTS/JTN     | 01          | RT            | 22-2                     | P            | A                  | (XXX)              |

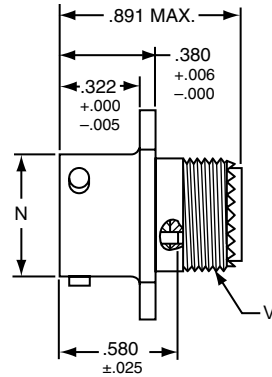
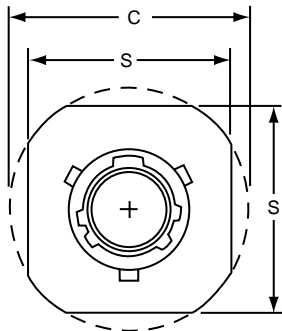

\* JT01RT-XX-XXX  
 \*\* JTS01RT-XX-XXX  
 \*\*\* JTN01RT-XX-XXX

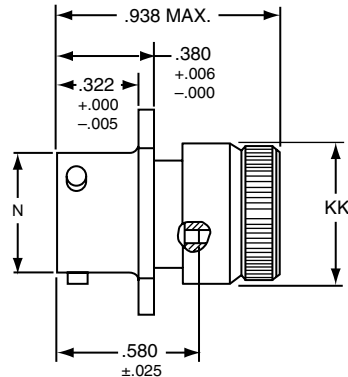

\* JT01RE-XX-XXX  
 \*\* JTS01RE-XX-XXX  
 \*\*\* JTN01RE-XX-XXX

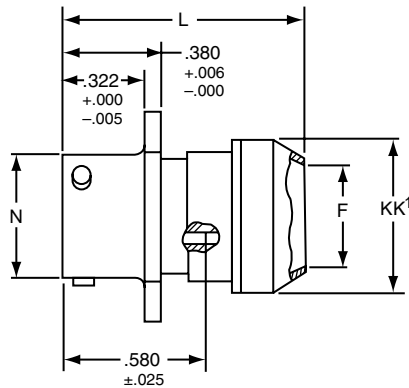

\* JT01RP-XX-XXX  
 \*\* JTS01RP-XX-XXX  
 \*\*\* JTN01RP-XX-XXX

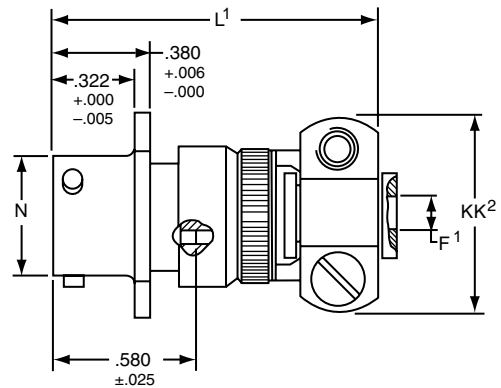

\* JT01RE-XX-XXX (SR)  
 \*\* JTS01RE-XX-XXX (SR)  
 \*\*\* JTN01RE-XX-XXX (SR)

- \* Standard Junior Tri-Lock
- \*\* High temperature version
- \*\*\* Clear iridite finish (gold color), N<sub>2</sub>O<sub>4</sub> resistant

| Shell Size | C Max. | F Dia. +.010 | F¹ Dia. +.010 -0.025 | L Max. | L¹ Max. | N Dia. +.001 -0.005 | S +.017 -0.016 | V Thread UNEF Class 2A (Plated) | KK Dia. Max. | KK¹ Dia. Max. | KK² Max. |
|------------|--------|--------------|----------------------|--------|---------|---------------------|----------------|---------------------------------|--------------|---------------|----------|
| 8          | .965   | .444         | .125                 | 1.031  | 1.562   | .473                | .812           | .4375-28                        | .578         | .625          | .812     |
| 10         | 1.089  | .558         | .188                 | 1.031  | 1.562   | .590                | .938           | .5625-24                        | .703         | .750          | .875     |
| 12         | 1.183  | .683         | .312                 | 1.031  | 1.562   | .750                | 1.031          | .6875-24                        | .828         | .875          | 1.000    |
| 14         | 1.277  | .808         | .375                 | 1.031  | 1.812   | .875                | 1.125          | .8125-20                        | .953         | 1.000         | 1.125    |
| 16         | 1.371  | .909         | .500                 | 1.031  | 1.812   | 1.000               | 1.219          | .9375-20                        | 1.078        | 1.125         | 1.188    |
| 18         | 1.465  | 1.034        | .625                 | 1.031  | 1.812   | 1.125               | 1.312          | 1.0625-18                       | 1.203        | 1.250         | 1.438    |
| 20         | 1.589  | 1.159        | .625                 | 1.031  | 1.812   | 1.250               | 1.438          | 1.1875-18                       | 1.328        | 1.375         | 1.438    |
| 22         | 1.715  | 1.284        | .750                 | 1.031  | 1.938   | 1.375               | 1.562          | 1.3125-18                       | 1.453        | 1.500         | 1.625    |
| 24         | 1.838  | 1.409        | .800                 | 1.109  | 1.938   | 1.500               | 1.688          | 1.4375-18                       | 1.578        | 1.625         | 1.719    |

All dimensions for reference only.

# JT02RE (MS27499) Series II – Crimp JT02RE (053) (MS27513)

## Box Mounting Receptacle

**PART #** Part number reference. To complete, see how to order pages 46-50.

**Commercial**

| Connector Type | Shell Style | Service Class | Shell Size & Insert Arrg | Contact Type | Alternate Position | Special Variations |
|----------------|-------------|---------------|--------------------------|--------------|--------------------|--------------------|
| JT/JTS/JTN     | 02          | RE            | 22-2                     | P            | A                  | (XXX)              |

**Military**

| MS Number | Service Class | Shell Size | Finish | Insert Arrg | Contact Style (P or S) | Alternate Position |
|-----------|---------------|------------|--------|-------------|------------------------|--------------------|
| MS27499   | E             | 14         | A      | 18          | P                      | A                  |
| MS27513   | E             | 14         | A      | 18          | P                      | A                  |

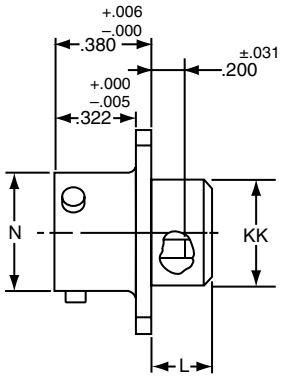
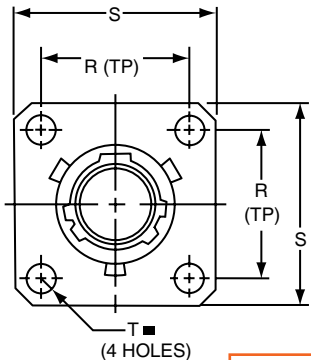

- \* JT02RE-XX-XXX (MS27499)
- \*\* JTS02RE-XX-XXX
- \*\*\* JTN02RE-XX-XXX

- \* JT02RE-XX-XXX (053) (MS27513)
- \*\* JTS02RE-XX-XXX (053)
- \*\*\* JTN02RE-XX-XXX (053)

■  $\text{⊕} \text{ } .005 \text{ DIA } (M)$

- \* Standard Junior Tri-Lock
- \*\* High temperature version
- \*\*\* Clear iridite finish (gold color), N<sub>2</sub>O<sub>4</sub> resistant

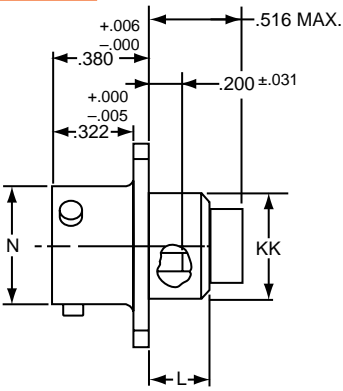

| Shell Size | L Max. | N<br>+.001<br>-.005 | R (TP) | S ±.016 | T ±.005 | KK Dia. Max. |
|------------|--------|---------------------|--------|---------|---------|--------------|
| 8          | .286   | .473                | .594   | .812    | .120    | .438         |
| 10         | .286   | .590                | .719   | .938    | .120    | .563         |
| 12         | .286   | .750                | .812   | 1.031   | .120    | .688         |
| 14         | .286   | .875                | .906   | 1.125   | .120    | .813         |
| 16         | .286   | 1.000               | .969   | 1.219   | .120    | .938         |
| 18         | .286   | 1.125               | 1.062  | 1.312   | .120    | 1.047        |
| 20         | .286   | 1.250               | 1.156  | 1.438   | .120    | 1.172        |
| 22         | .286   | 1.375               | 1.250  | 1.562   | .120    | 1.297        |
| 24         | .286   | 1.500               | 1.375  | 1.688   | .147    | 1.422        |

All dimensions for reference only.  
NOTE: For applications requiring an environmental seal, please refer to JT00R, page 47.

- III 38999
- II
- I
- SJT
- Matrix 2 26482
- Matrix Pyle 83723 III
- Crimp Rear Release Matrix 5015
- 26500 Pyle
- Printed Circuit Board
- EMI Filter Transient
- Fiber Optics
- High Speed Contacts
- Options Others

### Back Panel Mounting

- 38999 III
- SJT I
- 26482 Matrix 2
- 83723 III Matrix Pyle
- 5015 Crimp Rear Release Matrix
- 26500 Pyle
- Printed Circuit Board
- EMI Filter Transient
- Fiber Optics
- High Speed Contacts
- Options Others

**PART #** Part number reference. To complete, see how to order pages 46-50.  
**Commercial**

| Connector Type | Shell Style | Service Class | Shell Size & Insert Arrg | Contact Type | Alternate Position | Special Variations |
|----------------|-------------|---------------|--------------------------|--------------|--------------------|--------------------|
| JT/JTPS/JTPN   | 02          | RE            | 22-2                     | P            | A                  | (XXX)              |

**Military**

| MS Number | Service Class | Shell Size | Finish | Insert Arrg | Contact Style (P or S) | Alternate Position |
|-----------|---------------|------------|--------|-------------|------------------------|--------------------|
| MS27508   | E             | 14         | A      | 18          | P                      | A                  |

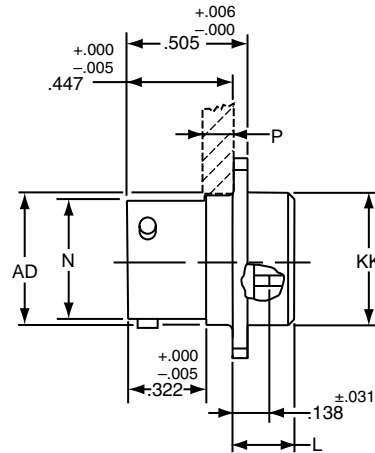
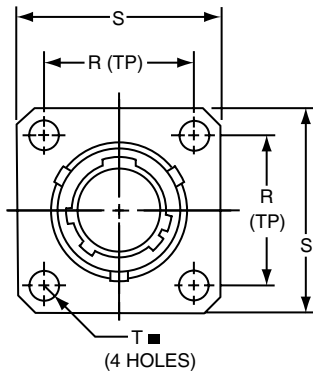

\* JTP02RE-XX-XXX (MS27508E)  
 \*\* JTPS02RE-XX-XXX  
 \*\*\*JTPN02RE-XX-XXX

■ ⊕ .005 DIA M

- \* Standard Junior Tri-Lock
- \*\* High temperature version
- \*\*\* Clear iridite finish (gold color), N<sub>2</sub>O<sub>4</sub> resistant

| Shell Size | L Max. | N +.001<br>-.005 | P Max. Panel Thickness | R (TP) | S ±.016 | T Dia. ±.005 | AD Dia. ±.005 | KK Dia. Max. |
|------------|--------|------------------|------------------------|--------|---------|--------------|---------------|--------------|
| 8          | .225   | .473             | .147                   | .594   | .812    | .120         | .516          | .531         |
| 10         | .225   | .590             | .152                   | .719   | .938    | .120         | .633          | .656         |
| 12         | .225   | .750             | .152                   | .812   | 1.031   | .120         | .802          | .828         |
| 14         | .225   | .875             | .152                   | .906   | 1.125   | .120         | .927          | .953         |
| 16         | .225   | 1.000            | .152                   | .969   | 1.219   | .120         | 1.052         | 1.078        |
| 18         | .225   | 1.125            | .152                   | 1.062  | 1.312   | .120         | 1.177         | 1.203        |
| 20         | .225   | 1.250            | .179                   | 1.156  | 1.438   | .120         | 1.302         | 1.328        |
| 22         | .225   | 1.375            | .179                   | 1.250  | 1.562   | .120         | 1.427         | 1.453        |
| 24         | .225   | 1.500            | .169                   | 1.375  | 1.688   | .147         | 1.552         | 1.578        |

All dimensions for reference only.

# JT06R (MS27473) Series II – Crimp Straight Plug

**PART # Commercial** Part number reference. To complete, see how to order pages 46-50.

| Connector Type | Shell Style | Service Class | Shell Size & Insert Arrg | Contact Type | Alternate Position | Special Variations |
|----------------|-------------|---------------|--------------------------|--------------|--------------------|--------------------|
| JT/JTS/JTN     | 06          | RE            | 22-2                     | P            | A                  | (XXX)              |

**Military**

| MS Number | Service Class | Shell Size | Finish | Insert Arrg | Contact Style (P or S) | Alternate Position |
|-----------|---------------|------------|--------|-------------|------------------------|--------------------|
| MS27473   | E             | 14         | A      | 18          | P                      | A                  |

III  
II  
I  
SJT  
**38999**

Matrix 2  
**26482**

Matrix Pyle  
**83723 III**

Crimp Rear Release Matrix  
**5015**

Pyle  
**26500**

Circuit Board  
**Printed**

Transient  
**EMI Filter**

Fiber Optics

High Speed  
**Contacts**

Options  
**Others**

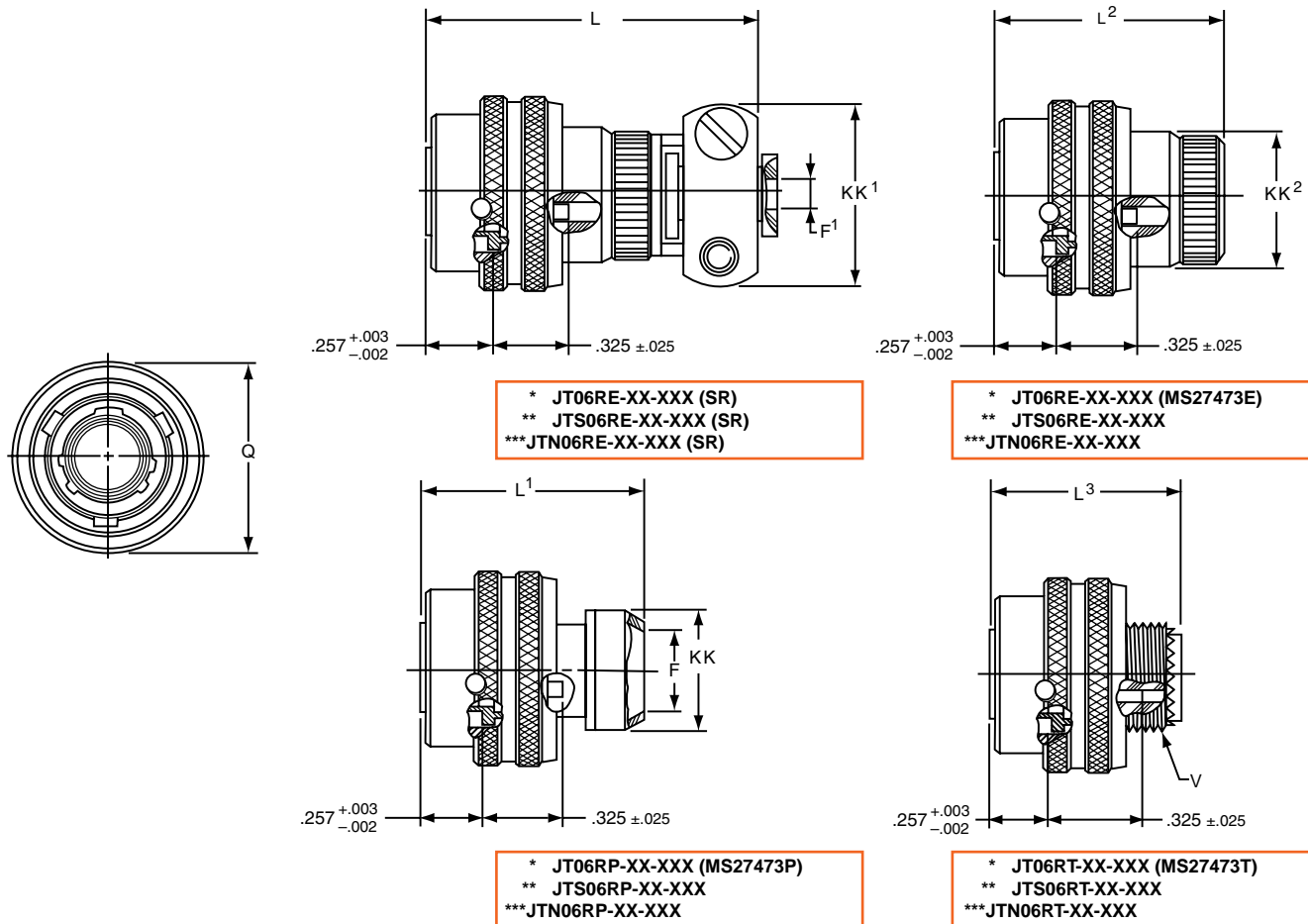

- \* Standard Junior Tri-Lock
- \*\* High temperature version
- \*\*\* Clear iridite finish (gold color), N<sub>2</sub>O<sub>4</sub> resistant

| Shell Size | F Dia. | F' Dia.<br>+.001<br>-.025 | L<br>Max. | L <sup>1</sup><br>Max. | L <sup>2</sup><br>Max. | L <sup>3</sup><br>Max. | Q Dia.<br>Max. | V Thread Modified |                     | KK Dia.<br>Max. | KK'<br>Max. | KK <sup>2</sup><br>Dia.<br>Max. |
|------------|--------|---------------------------|-----------|------------------------|------------------------|------------------------|----------------|-------------------|---------------------|-----------------|-------------|---------------------------------|
|            |        |                           |           |                        |                        |                        |                | Class 2A UNEF     | Modified Major Dia. |                 |             |                                 |
| 8          | .444   | .125                      | 1.562     | 1.000                  | .938                   | .891                   | .734           | .4375-28          | .421 – .417         | .625            | .812        | .578                            |
| 10         | .558   | .188                      | 1.562     | 1.000                  | .938                   | .891                   | .844           | .5625-24          | .542 – .538         | .750            | .875        | .703                            |
| 12         | .683   | .312                      | 1.562     | 1.000                  | .938                   | .891                   | 1.016          | .6875-24          | .667 – .663         | .875            | 1.000       | .828                            |
| 14         | .808   | .375                      | 1.812     | 1.000                  | .938                   | .891                   | 1.141          | .8125-20          | .791 – .787         | 1.000           | 1.125       | .953                            |
| 16         | .909   | .500                      | 1.812     | 1.000                  | .938                   | .891                   | 1.265          | .9375-20          | .916 – .912         | 1.125           | 1.188       | 1.078                           |
| 18         | 1.034  | .625                      | 1.812     | 1.000                  | .938                   | .891                   | 1.391          | 1.0625-18         | 1.034 – 1.030       | 1.250           | 1.438       | 1.203                           |
| 20         | 1.159  | .625                      | 1.812     | 1.000                  | .938                   | .891                   | 1.500          | 1.1875-18         | 1.158 – 1.154       | 1.375           | 1.438       | 1.328                           |
| 22         | 1.284  | .750                      | 1.938     | 1.000                  | .938                   | .891                   | 1.625          | 1.3125-18         | 1.283 – 1.279       | 1.500           | 1.625       | 1.453                           |
| 24         | 1.409  | .800                      | 1.938     | 1.062                  | .938                   | .891                   | 1.750          | 1.4375-18         | 1.408 – 1.404       | 1.625           | 1.719       | 1.578                           |

All dimensions for reference only.

- 38999 III
- SJT I II
- 26482 Matrix 2
- 83723 III Matrix Pyle
- 5015 Crimp Rear Release Matrix
- 26500 Pyle
- Printed Circuit Board
- EMI Filter Transient
- Fiber Optics
- High Speed Contacts
- Options Others

**PART #** Part number reference. To complete, see how to order pages 46-50.

| Connector Type | Shell Style | Service Class | Shell Size & Insert Arr | Contact Type | Alternate Position | Special Variations |
|----------------|-------------|---------------|-------------------------|--------------|--------------------|--------------------|
| JTG/JTNG       | 06          | RE            | 22-2                    | P            | A                  | (XXX)              |

**Military**

| MS Number | Service Class | Shell Size | Finish | Insert Arr | Contact Style (P or S) | Alternate Position |
|-----------|---------------|------------|--------|------------|------------------------|--------------------|
| MS27484   | E             | 14         | A      | 18         | P                      | A                  |

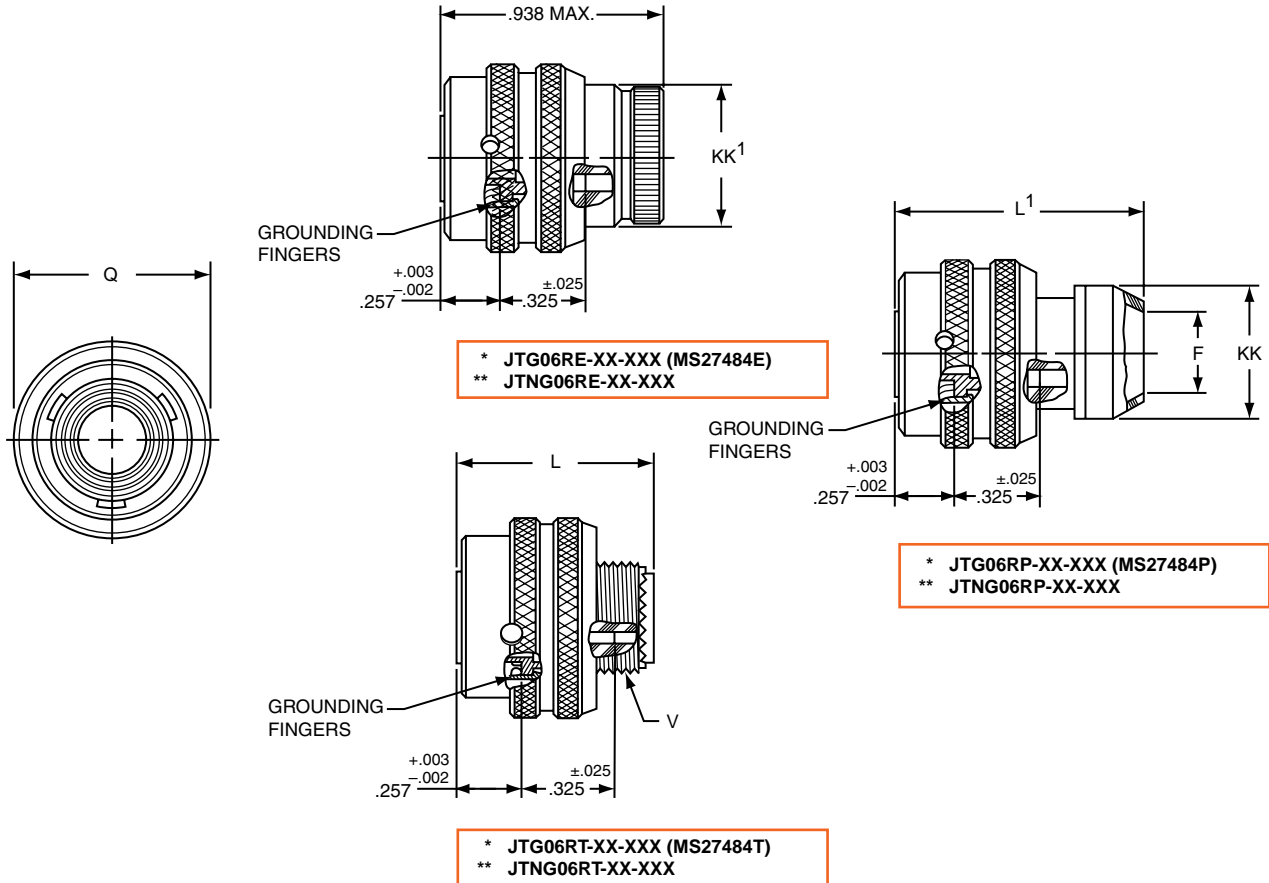

- \* Plug with grounding fingers
- \*\* Clear iridite finish (gold color), N<sub>2</sub>O<sub>4</sub> resistant

| Shell Size | F Dia. | L Max. | L <sup>1</sup> Max. | Q Dia Max. | V Thread Modified |                     | KK Dia. Max. | KK <sup>1</sup> Dia. Max. |
|------------|--------|--------|---------------------|------------|-------------------|---------------------|--------------|---------------------------|
|            |        |        |                     |            | Class 2A UNEF     | Modified Major Dia. |              |                           |
| 8          | .444   | .891   | 1.000               | .734       | .4375-28          | .421 – .417         | .625         | .578                      |
| 10         | .558   | .891   | 1.000               | .844       | .5625-24          | .542 – .538         | .750         | .703                      |
| 12         | .683   | .891   | 1.000               | 1.016      | .6875-24          | .667 – .663         | .875         | .828                      |
| 14         | .808   | .891   | 1.000               | 1.141      | .8125-20          | .791 – .787         | 1.000        | .953                      |
| 16         | .909   | .891   | 1.000               | 1.265      | .9375-20          | .916 – .912         | 1.125        | 1.078                     |
| 18         | 1.034  | .891   | 1.000               | 1.391      | 1.0625-18         | 1.034 – 1.030       | 1.250        | 1.203                     |
| 20         | 1.159  | .891   | 1.000               | 1.500      | 1.1875-18         | 1.158 – 1.154       | 1.375        | 1.328                     |
| 22         | 1.284  | .891   | 1.000               | 1.625      | 1.3125-18         | 1.283 – 1.279       | 1.500        | 1.453                     |
| 24         | 1.409  | .891   | 1.062               | 1.750      | 1.4375-18         | 1.408 – 1.404       | 1.625        | 1.578                     |

All dimensions for reference only.



# JT07R (MS27474) Series II – Crimp Jam Nut Receptacle



**PART #**  
Commercial Part number reference. To complete, see how to order pages 46-50.

| Connector Type | Shell Style | Service Class | Shell Size & Insert Arrg | Contact Type | Alternate Position | Special Variations |
|----------------|-------------|---------------|--------------------------|--------------|--------------------|--------------------|
| JT/JTS/JTN     | 07          | RE            | 22-2                     | P            | A                  | (XXX)              |

**Military**

| MS Number | Service Class | Shell Size | Finish | Insert Arrg | Contact Style (P or S) | Alternate Position |
|-----------|---------------|------------|--------|-------------|------------------------|--------------------|
| MS27474   | E             | 14         | A      | 18          | P                      | A                  |

- III 38999
- II SJT
- Matrix 2 26482
- Matrix Pyle 83723 III
- Release Matrix 5015 Crimp Rear
- 26500 Pyle
- Printed Circuit Board
- EM1 Filter Transient
- Fiber Optics
- High Speed Contacts
- Options Others

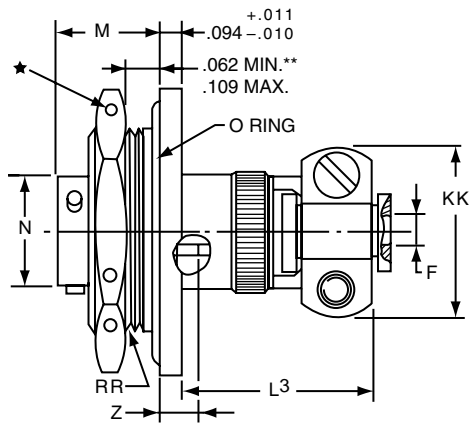
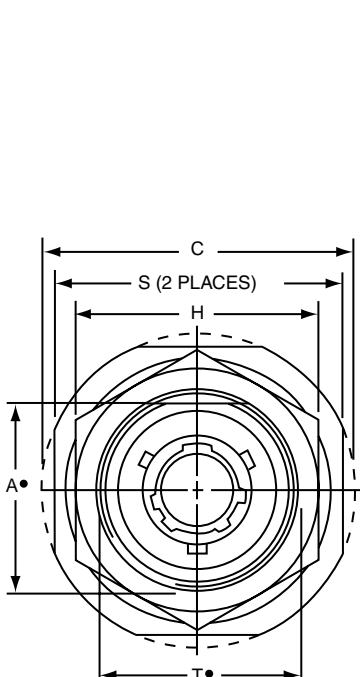

\* JT07RE-XX-XXX (SR)  
\*\*\* JTS07RE-XX-XXX (SR)  
\*\*\*\* JTN07RE-XX-XXX (SR)

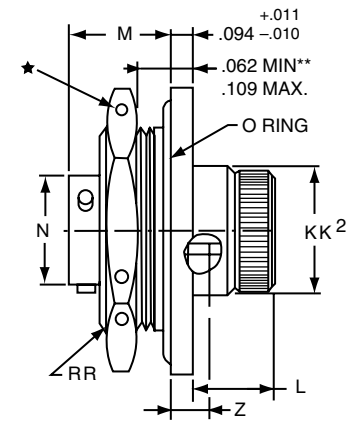

\* JT07RE-XX-XXX (MS27474E)  
\*\*\* JTS07RE-XX-XXX  
\*\*\*\* JTN07RE-XX-XXX

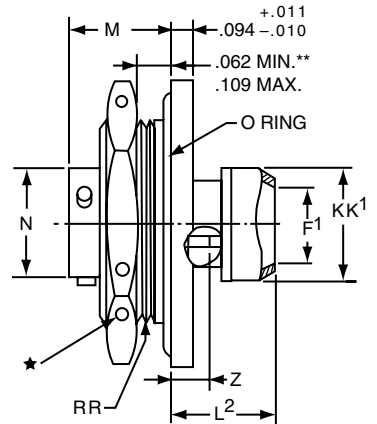

\* JT07RP-XX-XXX (MS27474P)  
\*\*\* JTS07RP-XX-XXX  
\*\*\*\* JTN07RP-XX-XXX

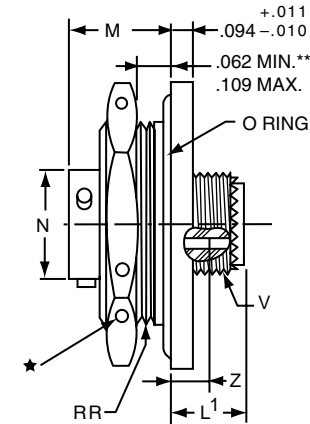

\* JT07RT-XX-XXX (MS27474T)  
\*\*\* JTS07RT-XX-XXX  
\*\*\*\* JTN07RT-XX-XXX

- ★ .059 Dia. Min. 3 lockwire holes. Formed lockwire hole design (6 holes) is optional.
- "D" shaped mounting hole dimensions.
- \* Standard Junior Tri-Lock
- \*\* Panel Thickness
- \*\*\* High temperature version
- \*\*\*\* Clear iridite finish (gold color), N<sub>2</sub>O<sub>4</sub> resistant

| Shell Size | A*<br>+.000<br>-.010 | C<br>Max. | F Dia.<br>+.010<br>-.025 | F' Dia. | H Hex<br>+.017<br>-.016 | L<br>Max. | L <sup>1</sup><br>Max. | L <sup>2</sup><br>Max. | L <sup>3</sup><br>Max. | M<br>±.005 | N Dia.<br>+.001<br>-.005 | S<br>±.016 | T*<br>+.010<br>-.000 | V Thread<br>UNEF<br>Class 2A | Z<br>±.031 | KK<br>Max. | KK <sup>1</sup><br>Dia.<br>Max. | KK <sup>2</sup><br>Max. | RR Thread<br>(Plated)<br>Class 2A |
|------------|----------------------|-----------|--------------------------|---------|-------------------------|-----------|------------------------|------------------------|------------------------|------------|--------------------------|------------|----------------------|------------------------------|------------|------------|---------------------------------|-------------------------|-----------------------------------|
| 8          | .830                 | 1.390     | .125                     | .444    | 1.062                   | .484      | .453                   | .563                   | 1.047                  | .438       | .473                     | 1.250      | .884                 | .4375-28                     | .144       | .812       | .625                            | .578                    | .8750-20UNEF                      |
| 10         | .955                 | 1.515     | .188                     | .558    | 1.188                   | .484      | .453                   | .563                   | 1.047                  | .438       | .590                     | 1.375      | 1.007                | .5625-24                     | .144       | .875       | .750                            | .703                    | 1.0000-20UNEF                     |
| 12         | 1.084                | 1.640     | .312                     | .683    | 1.312                   | .484      | .453                   | .563                   | 1.047                  | .438       | .750                     | 1.500      | 1.134                | .6875-24                     | .144       | 1.000      | .875                            | .828                    | 1.1250-18UNEF                     |
| 14         | 1.208                | 1.765     | .375                     | .808    | 1.438                   | .484      | .453                   | .563                   | 1.297                  | .438       | .875                     | 1.625      | 1.259                | .8125-20                     | .144       | 1.125      | 1.000                           | .953                    | 1.2500-18UNEF                     |
| 16         | 1.333                | 1.953     | .500                     | .909    | 1.562                   | .484      | .453                   | .563                   | 1.297                  | .438       | 1.000                    | 1.781      | 1.384                | .9375-20                     | .144       | 1.188      | 1.125                           | 1.078                   | 1.3750-18UNEF                     |
| 18         | 1.459                | 2.031     | .625                     | 1.034   | 1.688                   | .484      | .453                   | .563                   | 1.297                  | .438       | 1.125                    | 1.890      | 1.507                | 1.0625-18                    | .144       | 1.438      | 1.250                           | 1.203                   | 1.5000-18UNEF                     |
| 20         | 1.576                | 2.156     | .625                     | 1.159   | 1.812                   | .453      | .422                   | .531                   | 1.266                  | .464       | 1.250                    | 2.016      | 1.634                | 1.1875-18                    | .188       | 1.438      | 1.375                           | 1.328                   | 1.6250-18UNEF                     |
| 22         | 1.701                | 2.280     | .750                     | 1.284   | 2.000                   | .453      | .422                   | .531                   | 1.391                  | .464       | 1.375                    | 2.140      | 1.759                | 1.3125-18                    | .188       | 1.625      | 1.500                           | 1.453                   | 1.7500-18UNS                      |
| 24         | 1.826                | 2.405     | .800                     | 1.409   | 2.125                   | .375      | .422                   | .609                   | 1.391                  | .464       | 1.500                    | 2.265      | 1.884                | 1.4375-18                    | .188       | 1.719      | 1.625                           | 1.578                   | 1.8750-16UN                       |

All dimensions for reference only.

38999 III  
SJT I II III  
26482 Matrix 2  
83723 III Pyle  
Matrix Pyle  
5015 Crimp Rear Release Matrix  
26500 Pyle  
Printed Circuit Board  
EMI Filter Transient  
Fiber Optics  
High Speed Contacts  
Options Others

**PART #** Part number reference. To complete, see how to order pages 46-50.  
**Commercial**

| Connector Type | Shell Style | Service Class | Shell Size & Insert Arrg | Contact Type | Alternate Position | Special Variations |
|----------------|-------------|---------------|--------------------------|--------------|--------------------|--------------------|
| JTL/JTLS/JTLN  | 07          | RP            | 22-2                     | P            | A                  | (XXX)              |

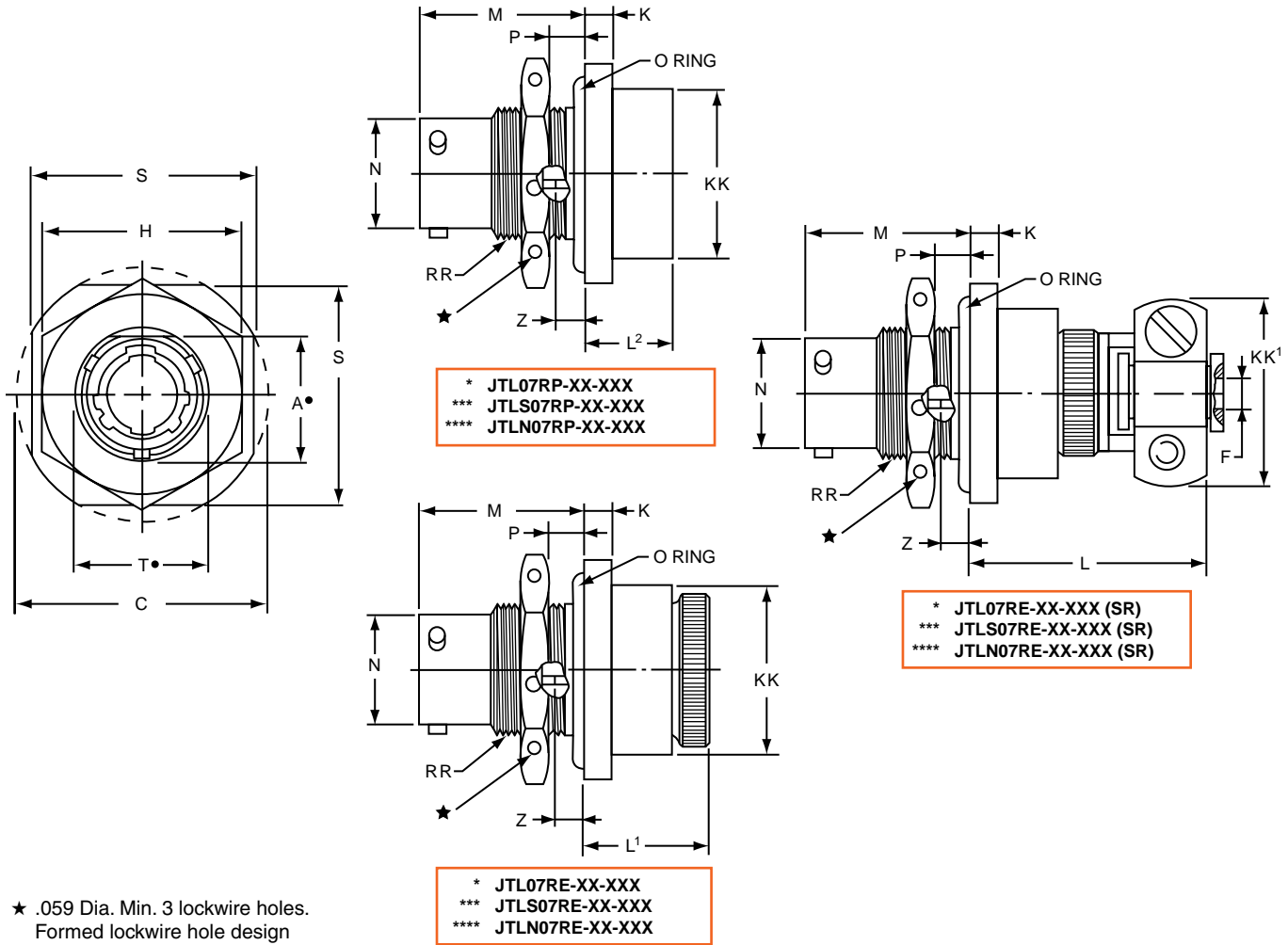

- ★ .059 Dia. Min. 3 lockwire holes. Formed lockwire hole design (6 holes) is optional.
- "D" shaped mounting hole dimensions.
- \* Miniature mounting dimensions
- \*\*\* High temperature version
- \*\*\*\* Clear iridite finish (gold color), N<sub>2</sub>O<sub>4</sub> resistant

| Shell Size | A*<br>+.000<br>-.010 | C<br>Max. | F Dia.<br>+.010<br>-.025 | H Hex<br>+.017<br>-.016 | K<br>+.011<br>-.010 | L<br>Max. | L <sup>1</sup><br>Max. | L <sup>2</sup><br>Max. | M<br>±.005 | N Dia.<br>+.001<br>-.005 | P Panel Thickness |      | S<br>±.016 | T*<br>+.010<br>-.000 | Z<br>±.026 | KK Dia.<br>Max. | KK <sup>1</sup><br>Max. | RR Thread<br>Class 2A |
|------------|----------------------|-----------|--------------------------|-------------------------|---------------------|-----------|------------------------|------------------------|------------|--------------------------|-------------------|------|------------|----------------------|------------|-----------------|-------------------------|-----------------------|
|            |                      |           |                          |                         |                     |           |                        |                        |            |                          | Min.              | Max. |            |                      |            |                 |                         |                       |
| 8          | .542                 | 1.077     | .125                     | .750                    | .125                | 1.062     | .641                   | .375                   | .630       | .473                     | .062              | .125 | .938       | .572                 | .047       | .688            | .812                    | .5625-24UNEF          |
| 10         | .669                 | 1.203     | .188                     | .875                    | .125                | 1.062     | .641                   | .375                   | .630       | .590                     | .062              | .125 | 1.062      | .697                 | .047       | .812            | .875                    | .6875-24UNEF          |
| 12         | .830                 | 1.390     | .312                     | 1.062                   | .125                | 1.062     | .641                   | .375                   | .630       | .750                     | .062              | .125 | 1.250      | .844                 | .047       | .938            | 1.000                   | .8750-20UNEF          |
| 14         | .955                 | 1.515     | .375                     | 1.188                   | .125                | 1.062     | .641                   | .375                   | .630       | .875                     | .062              | .125 | 1.375      | 1.007                | .047       | 1.062           | 1.125                   | 1.0000-20UNEF         |
| 16         | 1.084                | 1.640     | .500                     | 1.312                   | .125                | 1.062     | .641                   | .375                   | .630       | 1.000                    | .062              | .125 | 1.500      | 1.134                | .047       | 1.188           | 1.188                   | 1.1250-18UNEF         |
| 18         | 1.208                | 1.765     | .625                     | 1.438                   | .125                | 1.062     | .641                   | .375                   | .630       | 1.125                    | .062              | .125 | 1.625      | 1.259                | .047       | 1.312           | 1.438                   | 1.2500-18UNEF         |
| 20         | 1.333                | 1.953     | .625                     | 1.562                   | .156                | 1.062     | .703                   | .328                   | .755       | 1.250                    | .062              | .250 | 1.812      | 1.384                | .172       | 1.469           | 1.438                   | 1.3750-18UNEF         |
| 22         | 1.459                | 2.075     | .750                     | 1.688                   | .156                | 1.062     | .703                   | .328                   | .755       | 1.375                    | .062              | .250 | 1.938      | 1.507                | .172       | 1.594           | 1.625                   | 1.5000-18UNEF         |
| 24         | 1.575                | 2.203     | .800                     | 1.812                   | .156                | 1.062     | .703                   | .328                   | .755       | 1.500                    | .062              | .250 | 2.062      | 1.634                | .172       | 1.719           | 1.719                   | 1.6250-18UNEF         |

All dimensions for reference only.

# JT08R (MS27500) Series II – Crimp 90° Plug

**PART #** Part number reference. To complete, see how to order pages 46-50.  
**Commercial**

| Connector Type | Shell Style | Service Class | Shell Size & Insert Arrg | Contact Type | Alternate Position | Special Variations |
|----------------|-------------|---------------|--------------------------|--------------|--------------------|--------------------|
| JT/JTS/JTN     | 08          | RP            | 22-2                     | P            | A                  | (XXX)              |

**Military**

| MS Number | Service Class | Shell Size | Finish | Insert Arrg | Contact Style (P or S) | Alternate Position |
|-----------|---------------|------------|--------|-------------|------------------------|--------------------|
| MS27500   | E             | 14         | A      | 18          | P                      | A                  |

- \* JT08RP-XX-XXX
- \*\* JTS08RP-XX-XXX
- \*\*\* JTN08RP-XX-XXX

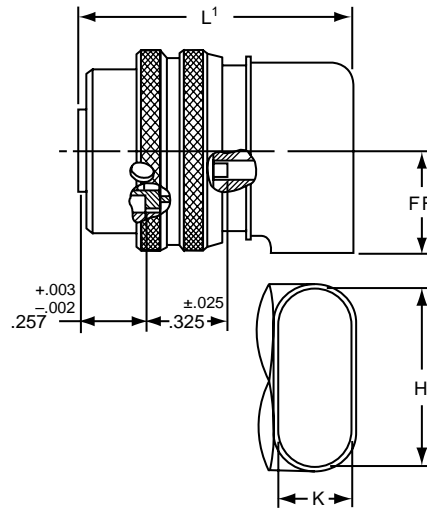
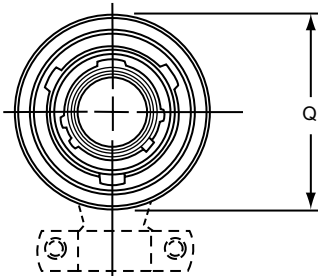

- \* JT08RE-XX-XXX (MS27500E)
- \*\* JTS08RE-XX-XXX
- \*\*\* JTN08RE-XX-XXX

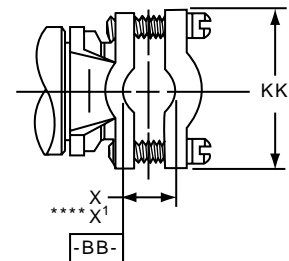
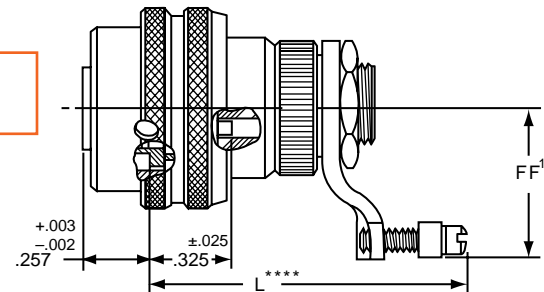

- \* Standard Junior Tri-Lock
- \*\* High temperature version
- \*\*\* Clear iridite finish (gold color), N<sub>2</sub>O<sub>4</sub> resistant
- \*\*\*\*Dimensions L and X<sup>1</sup> are applicable when the end of the screw is flush with the surface BB.

| Shell Size | H ±.010 | K ±.010 | L Max. | L' Max. | Q Dia. Max. | X Min. Cable | X' Max. Cable | FF Max. | FF' Max. | KK Max. |
|------------|---------|---------|--------|---------|-------------|--------------|---------------|---------|----------|---------|
| 8          | .547    | .156    | 1.578  | 1.125   | .734        | .082         | .234          | .438    | .984     | .755    |
| 10         | .709    | .188    | 1.578  | 1.156   | .844        | .082         | .234          | .516    | 1.016    | .755    |
| 12         | .829    | .281    | 1.656  | 1.250   | 1.016       | .114         | .328          | .594    | 1.078    | .817    |
| 14         | 1.000   | .438    | 1.844  | 1.406   | 1.141       | .176         | .457          | .656    | 1.203    | .943    |
| 16         | 1.021   | .500    | 2.000  | 1.469   | 1.265       | .238         | .634          | .719    | 1.265    | 1.067   |
| 18         | 1.145   | .562    | 2.046  | 1.531   | 1.391       | .208         | .614          | .781    | 1.328    | 1.149   |
| 20         | 1.270   | .625    | 2.125  | 1.594   | 1.500       | .302         | .608          | .844    | 1.359    | 1.399   |
| 22         | 1.395   | .688    | 2.250  | 1.656   | 1.625       | .302         | .823          | .906    | 1.421    | 1.399   |
| 24         | 1.520   | .750    | 2.422  | 1.797   | 1.750       | .332         | .853          | .969    | 1.703    | 1.587   |

All dimensions for reference only.

- III 38999
- II SJT
- Matrix 2 26482
- Matrix Pyle 83723 III
- Crimp Rear Release Matrix 5015
- Pyle 26500
- Printed Circuit Board
- EMI Filter Transient
- Fiber Optics
- High Speed Contacts
- Options Others

38999  
SJT

26482  
Matrix 2

83723 III  
Matrix Pyle

5015  
Crimp Rear Release Matrix

26500 Pyle

Printed  
Circuit Board

EMI Filter  
Transient

Fiber Optics

High Speed  
Contacts

Options  
Others

**PART #** Part number reference. To complete, see how to order pages 46-50.  
**Commercial**

| Connector Type | Shell Style | Service Class | Shell Size & Insert Arrg | Contact Type | Alternate Position | Special Variations |
|----------------|-------------|---------------|--------------------------|--------------|--------------------|--------------------|
| JT/JTS         | 00          | H             | 22-2                     | P            | A                  | (XXX)              |

**Military**

| MS Number | Service Class | Shell Size | Finish | Insert Arrg | Contact Style (P or S) | Alternate Position |
|-----------|---------------|------------|--------|-------------|------------------------|--------------------|
| MS27475   | Y             | 14         | A      | 18          | P                      | A                  |
| MS27482   | Y             | 14         | A      | 18          | P                      | A                  |
| MS27476   | Y             | 14         | A      | 18          | P                      | A                  |

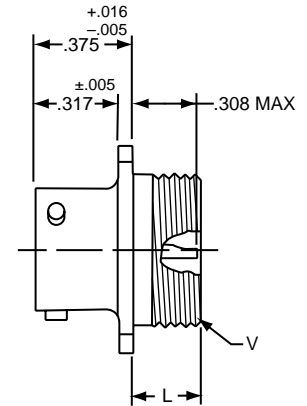
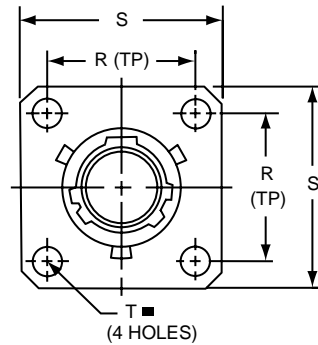

| Shell Size | L Max. | N +.001 - .005 | R (TP) | S ±.016 | T ±.005 | V Thread Class 2A |
|------------|--------|----------------|--------|---------|---------|-------------------|
| 8          | .234   | .473           | .594   | .812    | .120    | .5625-24UNEF      |
| 10         | .234   | .590           | .719   | .938    | .120    | .6875-24UNEF      |
| 12         | .234   | .750           | .812   | 1.031   | .120    | .8125-20UNEF      |
| 14         | .234   | .875           | .906   | 1.125   | .120    | .9375-20UNEF      |
| 16         | .234   | 1.000          | .969   | 1.219   | .120    | 1.0625-18UNEF     |
| 18         | .234   | 1.125          | 1.062  | 1.312   | .120    | 1.1875-18UNEF     |
| 20         | .234   | 1.250          | 1.156  | 1.438   | .120    | 1.3125-18UNEF     |
| 22         | .234   | 1.375          | 1.250  | 1.562   | .120    | 1.4375-18UNEF     |
| 24         | .313   | 1.500          | 1.375  | 1.688   | .147    | 1.5625-18UNEF     |

■ ⊕ .005 DIA (M)

- \* Standard Junior Tri-Lock
- \*\* Interfacial seal wafer
- \*\*\* High temperature version, interfacial seal wafer with stainless steel shell

\* JT00H-XX-XXX  
\*\* JT00Y-XX-XXX (MS27475YXXDXXX)  
\*\*\* JTS00Y-XX-XXX (MS27482YXXEXXX)

## JT02 (MS27476) Series II – Hermetic Box Mounting Receptacle

■ ⊕ .005 DIA (M)

- \* Standard Junior Tri-Lock
- \*\* Interfacial seal wafer
- \*\*\* High temperature version, interfacial seal wafer with stainless steel shell

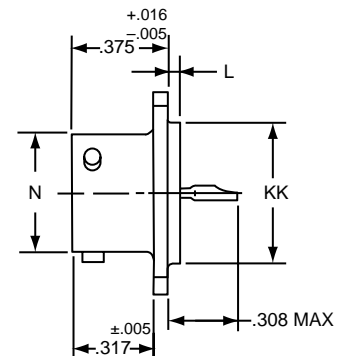
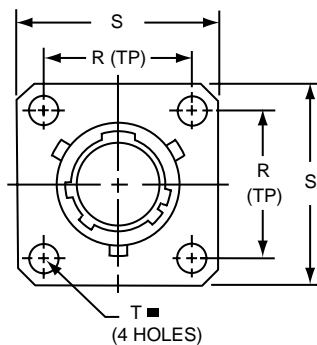

| Shell Size | L +.006 - .015 | N +.001 - .005 | R (TP) | S ±.016 | T ±.005 | KK +.001 - .005 |
|------------|----------------|----------------|--------|---------|---------|-----------------|
| 8          | .051           | .473           | .594   | .812    | .120    | .562            |
| 10         | .051           | .590           | .719   | .938    | .120    | .672            |
| 12         | .051           | .750           | .812   | 1.031   | .120    | .781            |
| 14         | .051           | .875           | .906   | 1.125   | .120    | .906            |
| 16         | .051           | 1.000          | .969   | 1.219   | .120    | 1.031           |
| 18         | .051           | 1.125          | 1.062  | 1.312   | .120    | 1.156           |
| 20         | .051           | 1.250          | 1.156  | 1.438   | .120    | 1.250           |
| 22         | .080           | 1.375          | 1.250  | 1.562   | .120    | 1.375           |
| 24         | .080           | 1.500          | 1.375  | 1.688   | .147    | 1.500           |

\* JT02H-XX-XXX  
\*\* JT02Y-XX-XXX (MS27476YXXDXXX)  
\*\*\* JTS02Y-XX-XXX (MS27476YXXEXXX)

All dimensions for reference only.

# JT07 (MS27477) Series II – Hermetic Jam Nut Receptacle

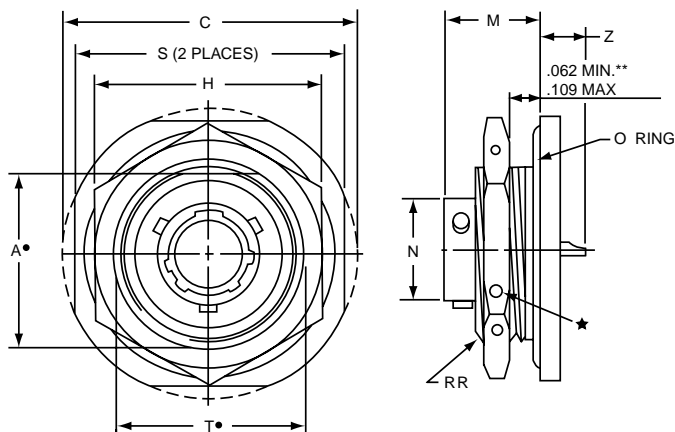

- \* Standard Junior Tri-Lock
- ★ .059 Dia. Min. 3 lockwire holes. Formed lockwire hole design (6 holes) is optional.
- “D” shaped mounting hole dimensions.
- \*\* Panel Thickness
- \*\*\* Interfacial seal wafer
- \*\*\*\*High temperature version, interfacial seal wafer with stainless steel shell

## PART #

### Commercial

Part number reference. To complete, see how to order pages 46-50.

| Connector Type | Shell Style | Service Class | Shell Size & Insert Arrg | Contact Type | Alternate Position | Special Variations |
|----------------|-------------|---------------|--------------------------|--------------|--------------------|--------------------|
| JT/JTS         | 07          | H             | 22-2                     | P            | A                  | (XXX)              |

### Military

| MS Number | Service Class | Shell Size | Finish | Insert Arrg | Contact Style (P or S) | Alternate Position |
|-----------|---------------|------------|--------|-------------|------------------------|--------------------|
| MS27477   | Y             | 14         | A      | 18          | P                      | A                  |
| MS27483   | Y             | 14         | A      | 18          | P                      | A                  |
| MS27478   | Y             | 14         | A      | 18          | P                      | A                  |
| MS27503   | Y             | 14         | A      | 18          | P                      | A                  |

- \* JT07H-XX-XXX
- \*\*\* JT07Y-XX-XX (MS27477YXXDXXX)
- \*\*\*\* JTS07Y-XX-XXX (MS27483YXXEXXX)

| Shell Size | A*<br>+.000<br>-.010 | C<br>Max. | H<br>+.017<br>-.016 | M<br>±.005 | N<br>+.001<br>-.005 | S<br>±.016 | T*<br>+.010<br>-.000 | Z Max. | RR Thread<br>Class 2A |
|------------|----------------------|-----------|---------------------|------------|---------------------|------------|----------------------|--------|-----------------------|
| 8          | .830                 | 1.390     | 1.062               | .438       | .473                | 1.250      | .884                 | .244   | .8750-20UNEF          |
| 10         | .955                 | 1.515     | 1.188               | .438       | .590                | 1.375      | 1.007                | .244   | 1.0000-20UNEF         |
| 12         | 1.084                | 1.640     | 1.312               | .438       | .750                | 1.500      | 1.134                | .244   | 1.1250-18UNEF         |
| 14         | 1.208                | 1.765     | 1.438               | .438       | .875                | 1.625      | 1.259                | .244   | 1.2500-18UNEF         |
| 16         | 1.333                | 1.953     | 1.562               | .438       | 1.000               | 1.781      | 1.384                | .244   | 1.3750-18UNEF         |
| 18         | 1.459                | 2.031     | 1.688               | .438       | 1.125               | 1.890      | 1.507                | .244   | 1.5000-18UNEF         |
| 20         | 1.576                | 2.156     | 1.812               | .464       | 1.250               | 2.016      | 1.634                | .218   | 1.6250-18UNEF         |
| 22         | 1.701                | 2.280     | 2.000               | .464       | 1.375               | 2.140      | 1.759                | .218   | 1.7500-18UNS          |
| 24         | 1.826                | 2.405     | 2.125               | .464       | 1.500               | 2.265      | 1.884                | .218   | 1.8750-16UN           |

# JTI (MS27478) Series II – Hermetic Solder Mounting Receptacle

- \* Standard Junior Tri-Lock
- \*\* Interfacial seal wafer
- \*\*\* High temperature version, interfacial seal wafer with stainless steel shell

- \* JTIH-XX-XXX
- \*\* JTIY-XX-XX (MS27478YXXDXXX)
- \*\*\* JTSIY-XX-XXX (MS27503YXXEXXX)

| Shell Size | L<br>+.011<br>-.010 | N<br>+.001<br>-.005 | GG<br>+.011<br>-.010 | KK<br>+.001<br>-.005 |
|------------|---------------------|---------------------|----------------------|----------------------|
| 8          | .078                | .473                | .687                 | .562                 |
| 10         | .078                | .590                | .797                 | .672                 |
| 12         | .078                | .750                | .906                 | .781                 |
| 14         | .078                | .875                | 1.031                | .906                 |
| 16         | .078                | 1.000               | 1.156                | 1.031                |
| 18         | .078                | 1.125               | 1.281                | 1.156                |
| 20         | .078                | 1.250               | 1.375                | 1.250                |
| 22         | .107                | 1.375               | 1.500                | 1.375                |
| 24         | .107                | 1.500               | 1.625                | 1.500                |

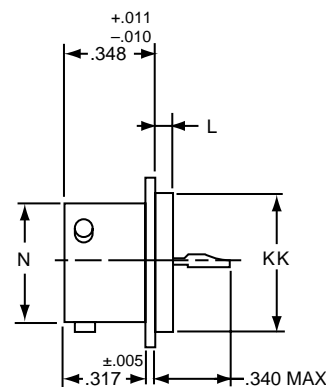
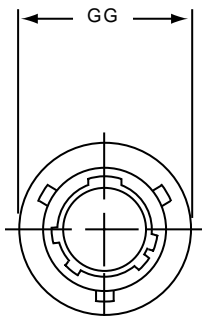

All dimensions for reference only.  
Weld mounting hermetic receptacle also available. Consult Amphenol, Sidney, NY for availability and dimensions.

All dimensions for reference only.

- III 38999
- II SJT
- Matrix 2 26482
- Matrix Pyle 83723 III
- Release Matrix 5015
- 26500 Pyle
- Printed Circuit Board
- EMI Filter Transient
- Fiber Optics
- High Speed Contacts
- Options Others



Military qualified to MIL-DTL-27599

**PART #** Part number reference. To complete, see how to order pages 46-50.

| Connector Type | Shell Style | Service Class | Shell Size & Insert Arrg | Contact Type | Alternate Position | Special Variations |
|----------------|-------------|---------------|--------------------------|--------------|--------------------|--------------------|
| JT/JTN         | 07          | RE            | 22-2                     | P            | A                  | (XXX)              |

**Military**

| MS Number | Service Class | Shell Size | Finish | Insert Arrg | Contact Style (P or S) | Alternate Position |
|-----------|---------------|------------|--------|-------------|------------------------|--------------------|
| MS27334   | P             | 14         | A      | 18          | P                      | A                  |
| MS27335   | T             |            |        |             |                        |                    |

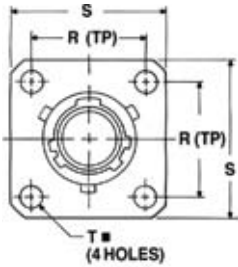

⊕ .005 DIA Ⓜ

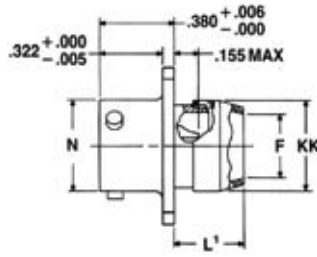

\*JT00P-XX-XXX (MS27334P)  
\*JTN00P-XX-XXX

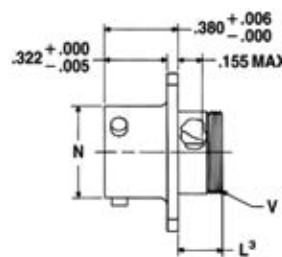

\*JT00A-XX-XXX  
\*JT00C-XX-XXX (MS27334T)  
\*JTN00A-XX-XXX  
\*JTN00C-XX-XXX

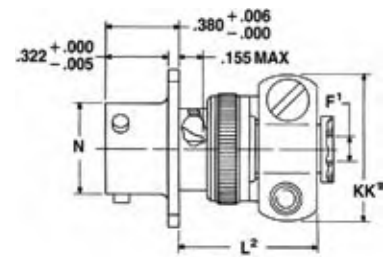

\*JT00A-XX-XXX(SR)  
\*JTN00A-XX-XXX(SR)  
\*JTN00C-XX-XXX(SR)

\* Standard Junior Tri-Lock

NOTE: For availability of back panel mounting types, consult Amphenol, Sidney, NY.

| Shell Size | F Dia. Min. | F1 +.010 - .025 | L1 Max. | L2 Max. | L3 Max. | N +.001 - .005 | R (TP) | S ±.016 | T ±.005 | V Thread Modified |                     | KK Dia. Max. | KK1 Max. |
|------------|-------------|-----------------|---------|---------|---------|----------------|--------|---------|---------|-------------------|---------------------|--------------|----------|
|            |             |                 |         |         |         |                |        |         |         | Size Class 2A     | Modified Major Dia. |              |          |
| 8          | .312        | .125            | .422    | .734    | .234    | .473           | .594   | .812    | .120    | .4375-28UNEF      | .421 - .417         | .500         | .812     |
| 10         | .429        | .188            | .422    | .734    | .234    | .590           | .719   | .938    | .120    | .5625-24UNEF      | .542 - .538         | .625         | .875     |
| 12         | .543        | .312            | .422    | .734    | .234    | .750           | .812   | 1.031   | .120    | .6875-24UNEF      | .667 - .663         | .750         | 1.000    |
| 14         | .668        | .375            | .422    | .797    | .234    | .875           | .906   | 1.125   | .120    | .8125-20UNEF      | .791 - .787         | .875         | 1.125    |
| 16         | .793        | .500            | .422    | .797    | .234    | 1.000          | .969   | 1.219   | .120    | .9375-20UNEF      | .916 - .912         | 1.000        | 1.188    |
| 18         | .894        | .625            | .422    | .797    | .234    | 1.125          | 1.062  | 1.312   | .120    | 1.0625-18UNEF     | 1.034 - 1.030       | 1.109        | 1.438    |
| 20         | 1.019       | .625            | .422    | .859    | .234    | 1.250          | 1.156  | 1.438   | .120    | 1.1875-18UNEF     | 1.158 - 1.154       | 1.234        | 1.438    |
| 22         | 1.144       | .750            | .422    | .859    | .234    | 1.375          | 1.250  | 1.562   | .120    | 1.3125-18UNEF     | 1.283 - 1.279       | 1.359        | 1.625    |
| 24         | 1.269       | .800            | .422    | .922    | .313    | 1.500          | 1.375  | 1.688   | .147    | 1.4375-18UNEF     | 1.408 - 1.404       | 1.484        | 1.719    |

## JT02 (MS27335) Series II – Solder Box Mounting Receptacle

Military qualified to MIL-DTL-27599

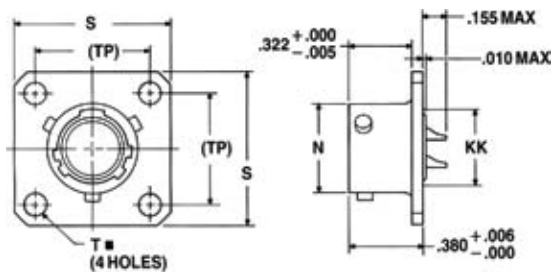

⊕ .005 DIA Ⓜ

\* Standard Junior Tri-Lock

NOTE: For availability of back panel mounting types, consult Amphenol, Sidney, NY.

\*JT02P-XX-XXX  
\*JT02A-XX-XXX  
\*JT02C-XX-XXX (MS27335T)  
\*JTN02P-XX-XXX  
\*JTN02A-XX-XXX  
\*JTN02C-XX-XXX

| Shell Size | N +.001 - .005 | R (TP) | S ±.016 | T ±.005 | KK Max. |
|------------|----------------|--------|---------|---------|---------|
| 8          | .473           | .594   | .812    | .120    | .391    |
| 10         | .590           | .719   | .938    | .120    | .508    |
| 12         | .750           | .812   | 1.031   | .120    | .622    |
| 14         | .875           | .906   | 1.125   | .120    | .749    |
| 16         | 1.000          | .969   | 1.219   | .120    | .872    |
| 18         | 1.125          | 1.062  | 1.312   | .120    | .976    |
| 20         | 1.250          | 1.156  | 1.438   | .120    | 1.101   |
| 22         | 1.375          | 1.250  | 1.562   | .120    | 1.226   |
| 24         | 1.500          | 1.375  | 1.688   | .147    | 1.351   |

All dimensions for reference only.

# JT06 (MS27336) Series II – Solder Straight Plug

**Military qualified to MIL-DTL-27599**

**PART # Commercial** Part number reference. To complete, see how to order pages 46-50.

| Connector Type  | Shell Style | Service Class | Shell Size & Insert Arrg | Contact Type | Alternate Position | Special Variations |
|-----------------|-------------|---------------|--------------------------|--------------|--------------------|--------------------|
| JT/JTN/JTG/JTNG | 06          | RE            | 22-2                     | P            | A                  | (XXX)              |

**Military**

| MS Number | Service Class | Shell Size | Finish | Insert Arrg | Contact Style (P or S) | Alternate Position |
|-----------|---------------|------------|--------|-------------|------------------------|--------------------|
| MS27336   | P             | 14         | A      | 18          | P                      | A                  |

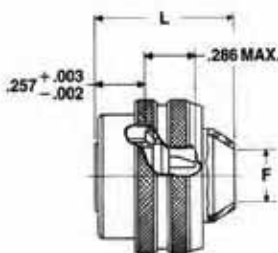
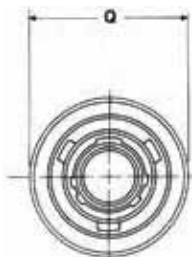

\*JT06P-XX-XXX (MS27336P)  
\*JTN06P-XX-XXX

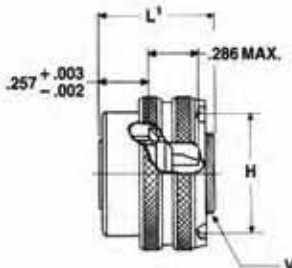

\*JT06A-XX-XXX (MS27336T)  
\*JTN06A-XX-XXX

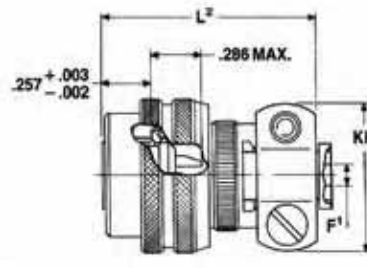

\*JT06A-XX-XXX(SR)  
\*JTN06A-XX-XXX(SR)

\*Standard Junior Tri-Lock

| Shell Size | F Min. | F' +.010 / -.025 | H +.010 / -.001 | L Max. | L1 Max. | L2 Max. | Q Max. | V Thread Modified |                     | KK Max. |
|------------|--------|------------------|-----------------|--------|---------|---------|--------|-------------------|---------------------|---------|
|            |        |                  |                 |        |         |         |        | Size Class 2A     | Modified Major Dia. |         |
| 8          | .312   | .125             | .635            | .812   | .625    | 1.109   | .734   | .4375-28UNEF      | .421 - .417         | .812    |
| 10         | .429   | .188             | .734            | .812   | .625    | 1.109   | .844   | .5625-24UNEF      | .542 - .538         | .875    |
| 12         | .543   | .312             | .870            | .812   | .625    | 1.109   | 1.016  | .6875-24UNEF      | .667 - .663         | 1.000   |
| 14         | .668   | .375             | .996            | .812   | .625    | 1.172   | 1.141  | .8125-20UNEF      | .791 - .787         | 1.125   |
| 16         | .793   | .500             | 1.122           | .828   | .625    | 1.172   | 1.265  | .9375-20UNEF      | .916 - .912         | 1.188   |
| 18         | .894   | .625             | 1.246           | .828   | .625    | 1.172   | 1.391  | 1.0625-18UNEF     | 1.034 - 1.030       | 1.438   |
| 20         | 1.019  | .625             | 1.372           | .828   | .625    | 1.234   | 1.500  | 1.1875-18UNEF     | 1.158 - 1.154       | 1.438   |
| 22         | 1.144  | .750             | 1.496           | .828   | .625    | 1.234   | 1.625  | 1.3125-18UNEF     | 1.283 - 1.279       | 1.625   |
| 24         | 1.269  | .800             | 1.622           | .906   | .688    | 1.297   | 1.750  | 1.4375-18UNEF     | 1.408 - 1.404       | 1.719   |

**Military qualified to MIL-DTL-27599**

# JTG06A Series II – Solder Straight Plug (With Grounding Ring)

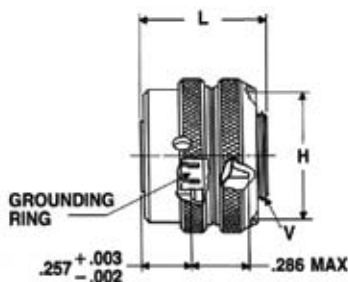
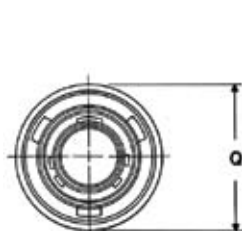

\*JTG06A-XX-XXX  
\*\*JTNG06A-XX-XXX

\* Plug with grounding fingers  
\*\* Coupling nut is clear iridite finish (gold color), shell and grounding fingers are gold plated N<sub>2</sub>O<sub>4</sub> resistant.

| Shell Size | H Dia. +.010 / -.001 | L Max. | Q Dia. Max. | V Thread Modified |                     |
|------------|----------------------|--------|-------------|-------------------|---------------------|
|            |                      |        |             | Size Class 2A     | Modified Major Dia. |
| 8          | .635                 | .625   | .734        | .4375-28UNEF      | .421 - .417         |
| 10         | .734                 | .625   | .844        | .5625-24UNEF      | .542 - .538         |
| 12         | .870                 | .625   | 1.016       | .6875-24UNEF      | .667 - .663         |
| 14         | .996                 | .625   | 1.141       | .8125-20UNEF      | .791 - .787         |
| 16         | 1.122                | .625   | 1.265       | .9375-20UNEF      | .916 - .912         |
| 18         | 1.246                | .625   | 1.391       | 1.0625-18UNEF     | 1.034 - 1.030       |
| 20         | 1.372                | .625   | 1.500       | 1.1875-18UNEF     | 1.158 - 1.154       |
| 22         | 1.496                | .625   | 1.625       | 1.3125-18UNEF     | 1.283 - 1.279       |
| 24         | 1.622                | .688   | 1.750       | 1.4375-18UNEF     | 1.408 - 1.404       |

All dimensions for reference only.

38999  
SJT  
26482 Matrix 2  
83723 III Matrix Pyle  
5015 Crimp Rear Release Matrix  
26500 Pyle  
Printed Circuit Board  
EMI Filter Transient  
Fiber Optics  
High Speed Contacts  
Options Others

38999 II III  
SJT  
26482 Matrix 2  
83723 III Pyle  
Matrix  
5015 Crimp Rear Release Matrix  
26500 Pyle  
Printed Circuit Board  
EMI Filter Transient  
Fiber Optics  
High Speed Contacts  
Options Others

### PART # Commercial

Part number reference. To complete, see how to order pages 46-50.

| Connector Type | Shell Style | Service Class | Shell Size & Insert Arrg | Contact Type | Alternate Position | Special Variations |
|----------------|-------------|---------------|--------------------------|--------------|--------------------|--------------------|
| JT/JTN         | P           | RE            | 22-2                     | P            | A                  | (XXX)              |

Military qualified to MIL-DTL-27599

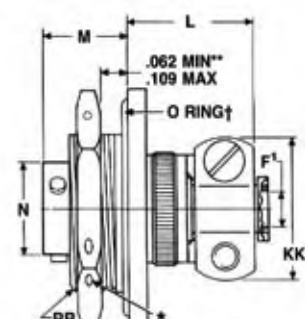
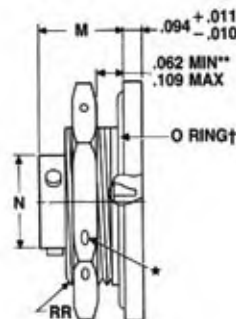
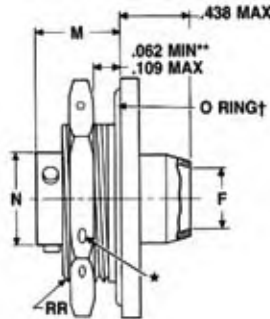
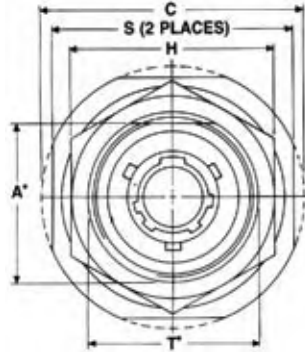

- ★ .059 dia. min. 3 lockwire holes
- "D" shaped mounting hole dimensions.
- \* Standard Junior Tri-Lock
- \*\* Panel thickness
- † O Ring not furnished with MS27337

\*JT07P-XX-XXX (MS27337P)  
\*JTN07P-XX-XXX

\*JT07A-XX-XXX  
\*JT07C-XX-XXX  
\*JTN07A-XX-XXX  
\*JTN07C-XX-XXX

\*JT07A-XX-XXX(SR)  
\*JTN07A-XX-XXX(SR)  
\*JTN07C-XX-XXX(SR)

| Shell Size | A*<br>+.000<br>-.010 | C<br>Max. | F<br>Min. | F1<br>+.010<br>-.025 | H<br>+.017<br>-.016 | L<br>Max. | M<br>±.005 | N<br>+.001<br>-.005 | S<br>±.016 | T*<br>+.010<br>-.000 | KK<br>Max. | RR<br>Thread<br>Class 2A |
|------------|----------------------|-----------|-----------|----------------------|---------------------|-----------|------------|---------------------|------------|----------------------|------------|--------------------------|
| 8          | .830                 | 1.390     | .312      | .125                 | 1.062               | .666      | .438       | .473                | 1.250      | .884                 | .812       | .8750-20UNEF             |
| 10         | .955                 | 1.515     | .429      | .188                 | 1.188               | .666      | .438       | .590                | 1.375      | 1.007                | .875       | 1.0000-20UNEF            |
| 12         | 1.084                | 1.640     | .543      | .312                 | 1.312               | .666      | .438       | .750                | 1.500      | 1.134                | 1.000      | 1.1250-18UNEF            |
| 14         | 1.208                | 1.765     | .668      | .375                 | 1.438               | .729      | .438       | .875                | 1.625      | 1.259                | 1.125      | 1.2500-18UNEF            |
| 16         | 1.333                | 1.953     | .793      | .500                 | 1.562               | .729      | .438       | 1.000               | 1.781      | 1.384                | 1.188      | 1.3750-18UNEF            |
| 18         | 1.459                | 2.031     | .894      | .625                 | 1.688               | .729      | .438       | 1.125               | 1.890      | 1.507                | 1.438      | 1.5000-18UNEF            |
| 20         | 1.576                | 2.156     | 1.019     | .625                 | 1.812               | .765      | .464       | 1.250               | 2.016      | 1.634                | 1.438      | 1.6250-18UNEF            |
| 22         | 1.701                | 2.280     | 1.144     | .750                 | 2.000               | .765      | .464       | 1.375               | 2.140      | 1.759                | 1.625      | 1.7500-18UNS             |
| 24         | 1.826                | 2.405     | 1.269     | .800                 | 2.125               | .828      | .464       | 1.500               | 2.265      | 1.884                | 1.719      | 1.8750-16UN              |

## JT08 Series II – Solder 90° Plug

Military qualified to MIL-DTL-27599

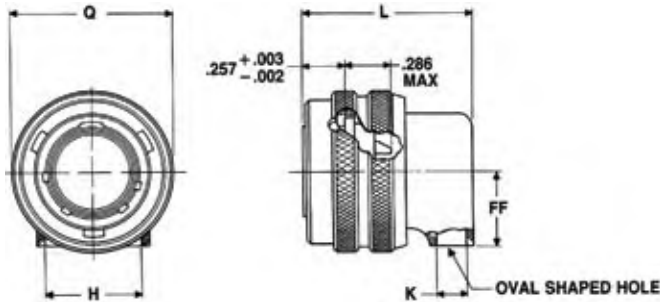

\*JT08P-XX-XXX  
\*JTN08P-XX-XXX

\* To complete order number see page 46.

| Shell Size | H<br>Min. | K<br>Min. | L<br>Max. | Q<br>Max. | FF<br>Max. |
|------------|-----------|-----------|-----------|-----------|------------|
| 8          | .396      | .126      | .891      | .734      | .391       |
| 10         | .532      | .141      | .906      | .844      | .438       |
| 12         | .694      | .173      | .938      | 1.016     | .516       |
| 14         | .814      | .266      | 1.031     | 1.141     | .594       |
| 16         | .985      | .423      | 1.188     | 1.265     | .656       |
| 18         | 1.006     | .485      | 1.250     | 1.391     | .719       |
| 20         | 1.130     | .547      | 1.312     | 1.500     | .781       |
| 22         | 1.255     | .610      | 1.375     | 1.625     | .844       |
| 24         | 1.380     | .673      | 1.516     | 1.750     | .906       |

All dimensions for reference only.

# Amphenol MIL-DTL-38999, Series I, LJT



## TABLE OF CONTENTS

### Combined MIL-DTL-38999 Series I, II, III

- Shell Size & Insert Arrangements Availability . . . . . 4-7
- Insert Arrangement Drawings . . . . . 8-14
- Specifications - Contact Ratings, Service Ratings, Finish Data . . . . . 15, 16

### MIL-DTL-38999, Series II JT and Series I LJT

- Features and Benefits . . . . . 45
- How to Order (Commercial). . . . . 46-48
- How to Order (Military). . . . . 49, 50

### LJT Shell Styles:

- Table of Contents. . . . . 67
- Crimp Wall Mounting Receptacle LJT00R (MS27466) . . . . . 68
- Crimp Wall Mount Recept. for Back Panel Mounting LJTPQ00R (MS27656) . . . . . 69
- Crimp Line Receptacle LJT01R . . . . . 70
- Crimp Box Mounting Receptacle LJT02R (MS27496),  
Crimp Box Mounting Receptacle for Back Panel Mounting LJTP02R (MS27505) 71
- Crimp Straight Plug LJT06R (MS27467). . . . . 72
- Crimp Jam Nut Receptacle LJT07R (MS27468). . . . . 73
- Hermetic Wall Mounting Receptacle LJT00 (MS27469). . . . . 74
- Hermetic Jam Nut Receptacle LJT07 (MS27470),  
Hermetic Solder Mounting Receptacle LJTL (MS27471) . . . . . 75
- Solder Wall Mounting Receptacle LJT00 (MS20026),  
Solder Line Receptacle LJT01 (MS20027) . . . . . 76
- Solder Straight Plug LJT06 (MS20028),  
Solder Jam Nut Receptacle LJT07 (MS20029) . . . . . 77
- Breakaway Fail-Safe Lanyard Release Plug 88-5388/91-5388 (MS27661) . . . . . 78, 79
- Breakaway Fail-Safe How to Order (Military /Commercial). . . . . 80
- Accessories, Contacts, and Tools see pages . . . . . 89-108



### MIL-DTL-38999 Series I Typical Markets:

- Military & Commercial Aviation
- Military Vehicles
- Missiles & Ordnance
- C4ISR





38999

SJT I

III

26482

Matrix 2

83723 III

Matrix Pyle

5015

Crimp Rear Release Matrix

26500 Pyle

Printed Circuit Board

EMI Filter Transient

Fiber Optics

High Speed Contacts

Options Others

**PART #** Part number reference. To complete, see how to order pages 46-50.

| Connector Type | Shell Style | Service Class | Shell Size & Insert Arrg | Contact Type | Alternate Position | Special Variations |
|----------------|-------------|---------------|--------------------------|--------------|--------------------|--------------------|
| LJT            | 00          | RE            | 22-2                     | P            | A                  | (XXX)              |

**Military**

| MS Number | Service Class | Shell Size | Finish | Insert Arrg | Contact Style (P or S) | Alternate Position |
|-----------|---------------|------------|--------|-------------|------------------------|--------------------|
| MS27466   | E             | 14         | A      | 18          | P                      | A                  |

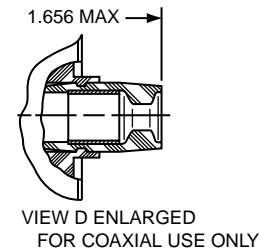
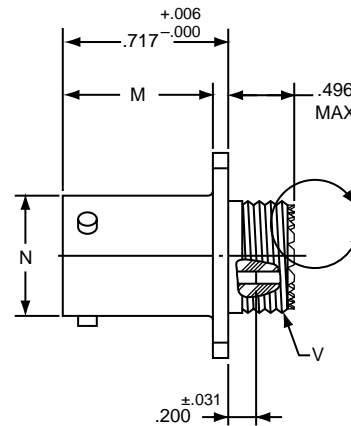
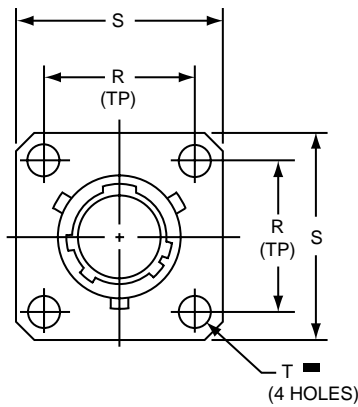

LJT00RE-XX-XXX (MS27466E)  
LJT00RT-XX-XXX (MS27466T)

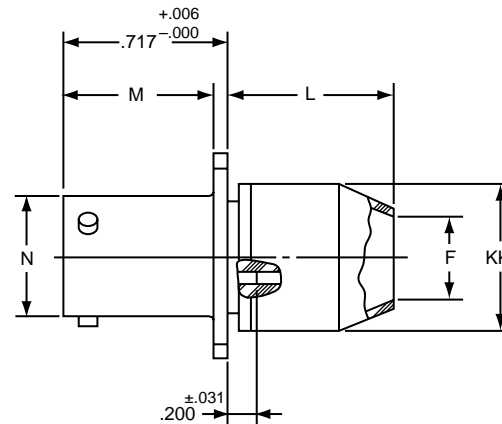

LJT00RP-XX-XXX (MS27466P)

⊕ .005 DIA ⊖

| Shell Size | F Dia. ±.010 | L Max. | M +.000 - .005 | N +.001 - .005 | R (TP) | S ±.016 | T Dia. ±.005 | V Thread Class 2A (Plated) | KK Dia. Max |
|------------|--------------|--------|----------------|----------------|--------|---------|--------------|----------------------------|-------------|
| 9          | .444         | .813   | .632           | .572           | .719   | .938    | .128         | .4375-28 UNEF              | .608        |
| 11         | .558         | .813   | .632           | .700           | .812   | 1.031   | .128         | .5625-24 UNEF              | .734        |
| 13         | .683         | .813   | .632           | .850           | .906   | 1.125   | .128         | .6875-24 UNEF              | .858        |
| 15         | .808         | .813   | .632           | .975           | .969   | 1.219   | .128         | .8125-20 UNEF              | .984        |
| 17         | .909         | .813   | .632           | 1.100          | 1.062  | 1.312   | .128         | .9375-20 UNEF              | 1.110       |
| 19         | 1.034        | .813   | .632           | 1.207          | 1.156  | 1.438   | .128         | 1.0625-18 UNEF             | 1.234       |
| 21         | 1.159        | .906   | .602           | 1.332          | 1.250  | 1.562   | .128         | 1.1875-18 UNEF             | 1.360       |
| 23         | 1.284        | .906   | .602           | 1.457          | 1.375  | 1.688   | .147         | 1.3125-18 UNEF             | 1.484       |
| 25         | 1.409        | .906   | .602           | 1.582          | 1.500  | 1.812   | .147         | 1.4375-18 UNEF             | 1.610       |

All dimensions for reference only.



# LJTPQ00R (MS27656) Series I – Crimp Wall Mounting Receptacle (Back Panel Mounting)



**PART #** Part number reference. To complete, see how to order pages 46-50.  
**Commercial**

| Connector Type | Shell Style | Service Class | Shell Size & Insert Arrg | Contact Type | Alternate Position | Special Variations |
|----------------|-------------|---------------|--------------------------|--------------|--------------------|--------------------|
| LJTPQ          | 00          | RE            | 22-2                     | P            | A                  | (XXX)              |

**Military**

| MS Number | Service Class | Shell Size | Finish | Insert Arrg | Contact Style (P or S) | Alternate Position |
|-----------|---------------|------------|--------|-------------|------------------------|--------------------|
| MS27656   | E             | 14         | A      | 18          | P                      | A                  |

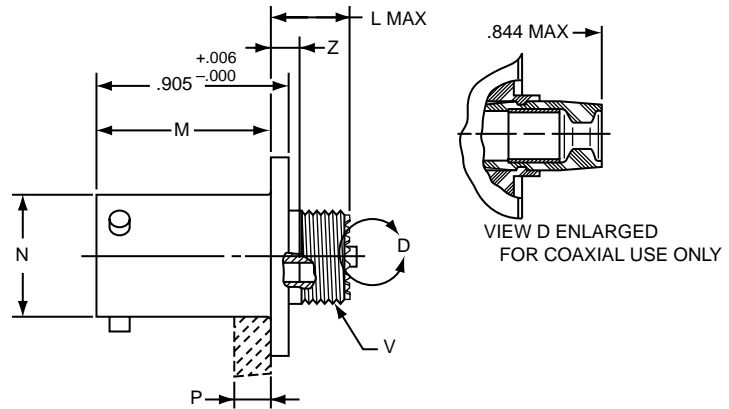
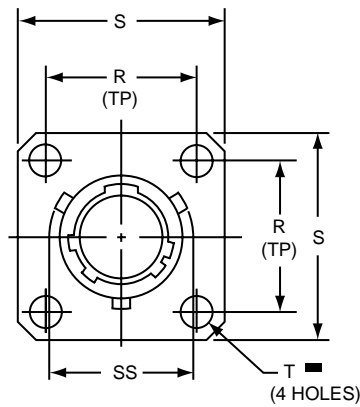

LJTPQ00RE-XX-XXX (MS27656E)  
LJTPQ00RT-XX-XXX (MS27656T)

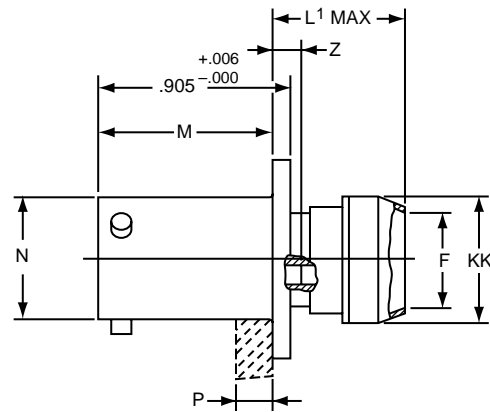

LJTPQ00RP-XX-XXX (MS27656P)

⊕ .005 DIA Ⓜ

| Shell Size | F Dia. ±.010 | L Max. | L' Max. | M +.000 - .005 | N Dia. | P Max. Panel Thickness | R (TP) | S +.011 - .010 | T Dia. ±.005 | V Thread Class 2A (Plated) | Z Max | KK Dia. Max | SS Dia. +.000 - .016 |
|------------|--------------|--------|---------|----------------|--------|------------------------|--------|----------------|--------------|----------------------------|-------|-------------|----------------------|
| 9          | .444         | .453   | .641    | .820           | .572   | .234                   | .719   | .938           | .128         | .4375-28 UNEF              | .138  | .625        | .662                 |
| 11         | .558         | .453   | .641    | .820           | .700   | .234                   | .812   | 1.031          | .128         | .5625-24 UNEF              | .138  | .750        | .810                 |
| 13         | .683         | .453   | .641    | .820           | .850   | .234                   | .906   | 1.125          | .128         | .6875-24 UNEF              | .138  | .875        | .960                 |
| 15         | .808         | .453   | .641    | .820           | .975   | .234                   | .969   | 1.219          | .128         | .8125-20 UNEF              | .138  | 1.000       | 1.085                |
| 17         | .909         | .453   | .641    | .820           | 1.100  | .234                   | 1.062  | 1.312          | .128         | .9375-20 UNEF              | .138  | 1.125       | 1.210                |
| 19         | 1.034        | .453   | .641    | .820           | 1.207  | .234                   | 1.156  | 1.438          | .128         | 1.0625-18 UNEF             | .138  | 1.250       | 1.317                |
| 21         | 1.159        | .484   | .672    | .790           | 1.332  | .204                   | 1.250  | 1.562          | .128         | 1.1875-18 UNEF             | .168  | 1.375       | 1.442                |
| 23         | 1.284        | .484   | .672    | .790           | 1.457  | .204                   | 1.375  | 1.688          | .147         | 1.3125-18 UNEF             | .168  | 1.500       | 1.567                |
| 25         | 1.409        | .484   | .672    | .790           | 1.582  | .193                   | 1.500  | 1.812          | .147         | 1.4375-18 UNEF             | .168  | 1.625       | 1.692                |

All dimensions for reference only.  
Note: MS27656 superseded MS 27515.

- III 38999 SJT
- II 26482 Matrix 2
- I 83723 III Matrix Pyle
- 5015 Crimp Rear Release Matrix
- 26500 Pyle
- Printed Circuit Board
- EMI Filter Transient
- Fiber Optics
- High Speed Contacts
- Options Others

38999  
SJT I II III

26482  
Matrix 2

83723 III  
Matrix Pyle

5015  
Crimp Rear  
Release Matrix

26500 Pyle

Printed  
Circuit Board

EMI Filter  
Transient

Fiber Optics

High Speed  
Contacts

Options  
Others

**PART #** Part number reference. To complete, see how to order pages 46-50.  
**Commercial**

| Connector Type | Shell Style | Service Class | Shell Size & Insert Arrg | Contact Type | Alternate Position | Special Variations |
|----------------|-------------|---------------|--------------------------|--------------|--------------------|--------------------|
| LJT            | 01          | RE            | 22-2                     | P            | A                  | (XXX)              |

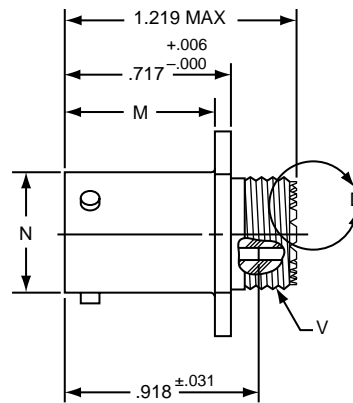
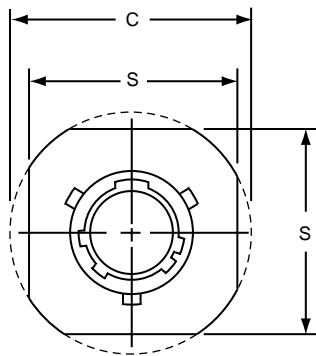

LJT01RE-XX-XXX  
LJT01RT-XX-XXX

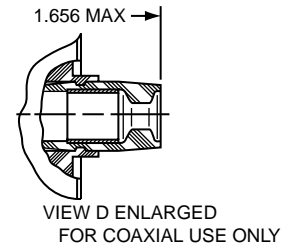

| Shell Size | C Max. | M +.000<br>-.005 | N +.001<br>-.005 | S ±.016 | V Thread Class 2A (Plated) |
|------------|--------|------------------|------------------|---------|----------------------------|
| 9          | 1.094  | .632             | .572             | .938    | .4375-28 UNEF              |
| 11         | 1.188  | .632             | .700             | 1.031   | .5625-24 UNEF              |
| 13         | 1.281  | .632             | .850             | 1.125   | .6875-24 UNEF              |
| 15         | 1.375  | .632             | .975             | 1.219   | .8125-20 UNEF              |
| 17         | 1.469  | .632             | 1.100            | 1.312   | .9375-20 UNEF              |
| 19         | 1.594  | .632             | 1.207            | 1.438   | 1.0625-18 UNEF             |
| 21         | 1.719  | .602             | 1.332            | 1.562   | 1.1875-18 UNEF             |
| 23         | 1.844  | .602             | 1.457            | 1.688   | 1.3125-18 UNEF             |
| 25         | 1.969  | .602             | 1.582            | 1.812   | 1.4375-18 UNEF             |

All dimensions for reference only.

# LJT02R (MS27496) – Crimp (Box Mount Recept.)

# LJTP02R (MS27505) – Crimp

## Box Mounting Receptacle (Back Panel Mounting)

### PART #

Part number reference. To complete, see how to order pages 46-50.

#### Commercial

| Connector Type | Shell Style | Service Class | Shell Size & Insert Arrg | Contact Type | Alternate Position | Special Variations |
|----------------|-------------|---------------|--------------------------|--------------|--------------------|--------------------|
| LJT/LJTP       | 02          | RE            | 22-2                     | P            | A                  | (XXX)              |

#### Military

| MS Number | Service Class | Shell Size | Finish | Insert Arrg | Contact Style (P or S) | Alternate Position |
|-----------|---------------|------------|--------|-------------|------------------------|--------------------|
| MS27496   | E             | 14         | A      | 18          | P                      | A                  |
| MS27505   | E             | 14         | A      | 18          | P                      | A                  |

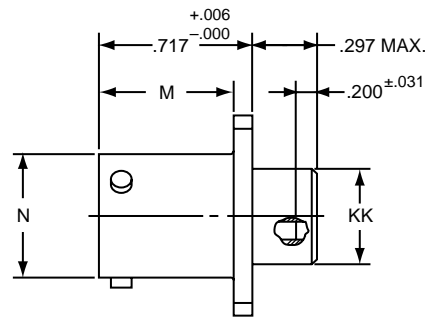
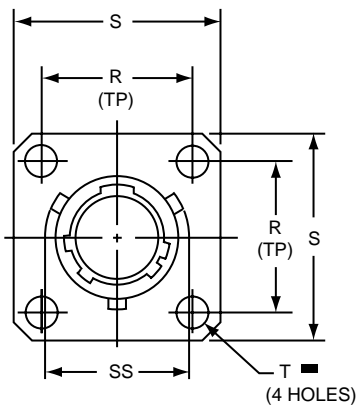

LJT02RE-XX-XXX (MS27496E)

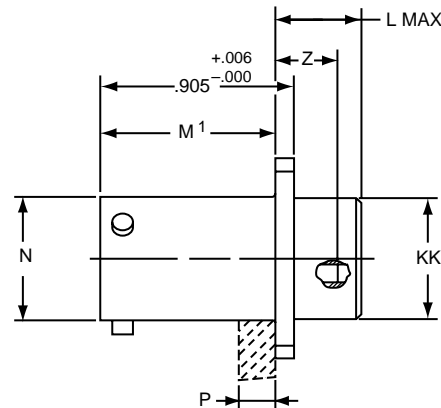

LJTP02RE-XX-XXX (MS27505E)

⊕ .005 DIA ⊕

| Shell Size | L Max. | M +.000<br>-.005 | M' +.001<br>-.005 | N Dia<br>+.001<br>-.005 | P Max.<br>Panel<br>Thickness | R (TP) | S<br>+.011<br>-.010 | T Dia.<br>±.005 | Z<br>±.031 | KK Dia.<br>+.006<br>-.005 | SS Dia.<br>+.000<br>-.016 |
|------------|--------|------------------|-------------------|-------------------------|------------------------------|--------|---------------------|-----------------|------------|---------------------------|---------------------------|
| 9          | .203   | .632             | .820              | .572                    | .234                         | .719   | .938                | .128            | .107       | .433                      | .662                      |
| 11         | .203   | .632             | .820              | .700                    | .234                         | .812   | 1.031               | .128            | .107       | .557                      | .810                      |
| 13         | .203   | .632             | .820              | .850                    | .234                         | .906   | 1.125               | .128            | .107       | .676                      | .960                      |
| 15         | .203   | .632             | .820              | .975                    | .234                         | .969   | 1.219               | .128            | .107       | .801                      | 1.085                     |
| 17         | .203   | .632             | .820              | 1.100                   | .234                         | 1.062  | 1.312               | .128            | .107       | .926                      | 1.210                     |
| 19         | .203   | .632             | .820              | 1.207                   | .234                         | 1.156  | 1.438               | .128            | .107       | 1.032                     | 1.317                     |
| 21         | .234   | .602             | .790              | 1.332                   | .204                         | 1.250  | 1.562               | .128            | .137       | 1.157                     | 1.442                     |
| 23         | .234   | .602             | .790              | 1.457                   | .204                         | 1.375  | 1.688               | .147            | .137       | 1.282                     | 1.567                     |
| 25         | .234   | .602             | .790              | 1.582                   | .193                         | 1.500  | 1.812               | .147            | .137       | 1.407                     | 1.692                     |

All dimensions for reference only.

38999  
SJT

26482  
Matrix 2

83723 III  
Matrix Pyle

5015  
Crimp Rear  
Release Matrix

26500 Pyle

Printed  
Circuit Board

EMI Filter  
Transient

Fiber Optics

High Speed  
Contacts

Options  
Others

- 38999 III
- SJT I II III
- 26482 Matrix 2
- 83723 III Pyle Matrix
- 5015 Crimp Rear Release Matrix
- 26500 Pyle
- Printed Circuit Board
- EMI Filter Transient
- Fiber Optics
- High Speed Contacts
- Options Others

**PART #** Part number reference. To complete, see how to order pages 46-50.

| Connector Type | Shell Style | Service Class | Shell Size & Insert Arrg | Contact Type | Alternate Position | Special Variations |
|----------------|-------------|---------------|--------------------------|--------------|--------------------|--------------------|
| LJT            | 06          | RE            | 22-2                     | P            | A                  | (XXX)              |

**Military**

| MS Number | Service Class | Shell Size | Finish | Insert Arrg | Contact Style (P or S) | Alternate Position |
|-----------|---------------|------------|--------|-------------|------------------------|--------------------|
| MS27467   | E             | 14         | A      | 18          | P                      | A                  |

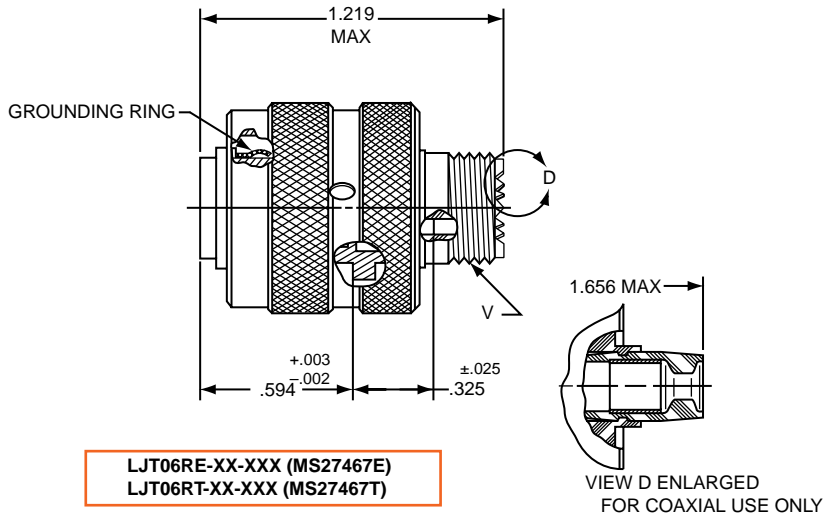
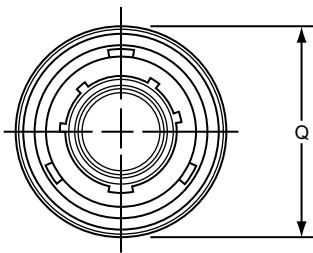

LJT06RE-XX-XXX (MS27467E)  
LJT06RT-XX-XXX (MS27467T)

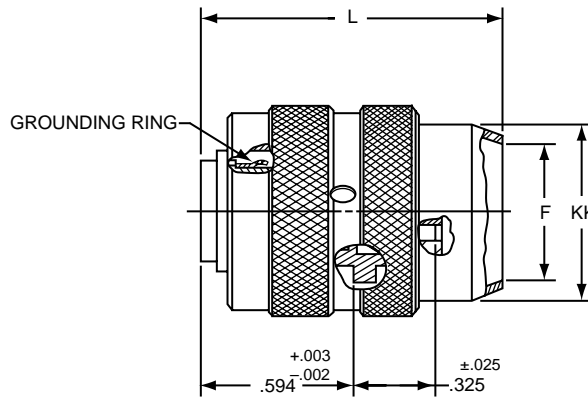

LJT06RP-XX-XXX (MS27467P)

| Shell Size | F Dia. ±.010 | L Max. | Q Max. | V Thread Class 2A (Plated) | KK Dia. Max. |
|------------|--------------|--------|--------|----------------------------|--------------|
| 9          | .444         | 1.531  | .844   | .4375-28 UNEF              | .608         |
| 11         | .528         | 1.531  | .969   | .5625-24 UNEF              | .734         |
| 13         | .683         | 1.531  | 1.141  | .6875-24 UNEF              | .858         |
| 15         | .808         | 1.531  | 1.266  | .8125-20 UNEF              | .984         |
| 17         | .909         | 1.531  | 1.391  | .9375-20 UNEF              | 1.110        |
| 19         | 1.034        | 1.531  | 1.500  | 1.0625-18 UNEF             | 1.234        |
| 21         | 1.159        | 1.625  | 1.625  | 1.1875-18 UNEF             | 1.360        |
| 23         | 1.284        | 1.625  | 1.750  | 1.3125-18 UNEF             | 1.484        |
| 25         | 1.409        | 1.625  | 1.875  | 1.4375-18 UNEF             | 1.610        |

All dimensions for reference only.

# LJT07R (MS27468) Series I – Crimp Jam Nut Receptacle

## PART # Commercial

Part number reference. To complete, see how to order pages 46-50.

| Connector Type | Shell Style | Service Class | Shell Size & Insert Arrg | Contact Type | Alternate Position | Special Variations |
|----------------|-------------|---------------|--------------------------|--------------|--------------------|--------------------|
| LJT            | 07          | RE            | 22-2                     | P            | A                  | (XXX)              |

## Military

| MS Number | Service Class | Shell Size | Finish | Insert Arrg | Contact Style (P or S) | Alternate Position |
|-----------|---------------|------------|--------|-------------|------------------------|--------------------|
| MS27498   | E             | 14         | A      | 18          | P                      | A                  |

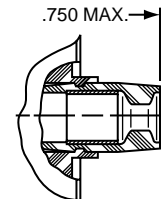
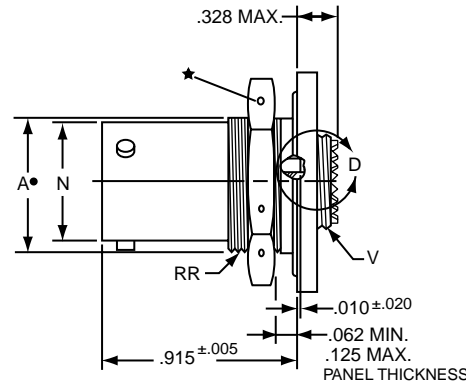
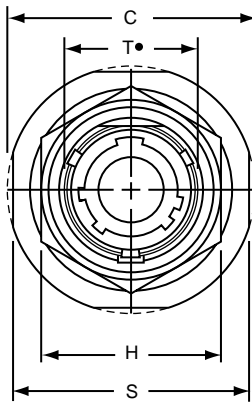

LJT07RE-XX-XXX (MS27468E)  
LJT07RT-XX-XXX (MS27468T)

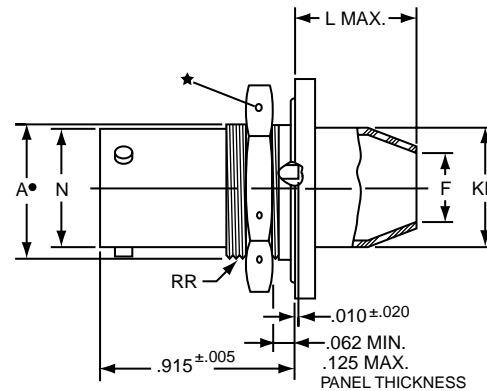

LJT07RP-XX-XXX (MS27468P)

- ★ .059 Dia. Min. 3 lockwire holes.
- Formed lockwire hole design (6 holes) is optional.
- “D” shaped mounting hole dimensions.

| Shell Size | A*<br>+.000<br>-.010 | C Max. | F Dia.<br>±.010 | H Hex<br>+.017<br>-.016 | L<br>Max. | N<br>+.001<br>-.005 | S ±.016 | T*<br>+.010<br>-.000 | V Thread Class 2A<br>(Plated) | KK Dia.<br>Max. | RR Thread<br>Class 2A (Plated) |
|------------|----------------------|--------|-----------------|-------------------------|-----------|---------------------|---------|----------------------|-------------------------------|-----------------|--------------------------------|
| 9          | .669                 | 1.199  | .444            | .875                    | .625      | .572                | 1.062   | .697                 | .4375-28 UNEF                 | .608            | .6875-24 UNEF                  |
| 11         | .769                 | 1.386  | .558            | 1.000                   | .625      | .700                | 1.250   | .822                 | .5625-24 UNEF                 | .734            | .8125-20 UNEF                  |
| 13         | .955                 | 1.511  | .683            | 1.188                   | .625      | .850                | 1.375   | 1.007                | .6875-24 UNEF                 | .858            | 1.0000-20 UNEF                 |
| 15         | 1.084                | 1.636  | .808            | 1.312                   | .625      | .975                | 1.500   | 1.134                | .8125-20 UNEF                 | .984            | 1.1250-18 UNEF                 |
| 17         | 1.208                | 1.761  | .909            | 1.438                   | .625      | 1.100               | 1.625   | 1.259                | .9375-20 UNEF                 | 1.110           | 1.2500-18 UNEF                 |
| 19         | 1.333                | 1.949  | 1.034           | 1.562                   | .656      | 1.207               | 1.812   | 1.384                | 1.0625-18 UNEF                | 1.234           | 1.3750-18 UNEF                 |
| 21         | 1.459                | 2.073  | 1.159           | 1.688                   | .750      | 1.332               | 1.938   | 1.507                | 1.1875-18 UNEF                | 1.360           | 1.5000-18 UNEF                 |
| 23         | 1.580                | 2.199  | 1.284           | 1.812                   | .750      | 1.457               | 2.062   | 1.634                | 1.3125-18 UNEF                | 1.484           | 1.6250-18 UNEF                 |
| 25         | 1.709                | 2.323  | 1.409           | 2.000                   | .750      | 1.582               | 2.188   | 1.759                | 1.4375-18 UNEF                | 1.610           | 1.7500-18 UNS                  |

All dimensions for reference only.

III 38999  
II 1 SJT  
Matrix 2 26482  
Matrix Pyle 83723 III  
Release Matrix 5015 Crimp Rear  
26500 Pyle  
Printed Circuit Board  
EM I Filter Transient  
Fiber Optics  
High Speed Contacts  
Options Others



- 38999 SJT I III
- 26482 Matrix 2
- 83723 III Matrix Pyle
- 5015 Crimp Rear Release Matrix
- 26500 Pyle
- Printed Circuit Board
- EMI Filter Transient
- Fiber Optics
- High Speed Contacts
- Options Others

**PART #** Part number reference. To complete, see how to order pages 46-50.  
**Commercial**

| Connector Type | Shell Style | Service Class | Shell Size & Insert Arrg | Contact Type | Alternate Position | Special Variations |
|----------------|-------------|---------------|--------------------------|--------------|--------------------|--------------------|
| LJT/LJTS       | 00          | Y             | 22-2                     | P            | A                  | (XXX)              |

**Military**

| MS Number | Service Class | Shell Size | Finish | Insert Arrg | Contact Style (P or S) | Alternate Position |
|-----------|---------------|------------|--------|-------------|------------------------|--------------------|
| MS27469   | Y             | 14         | D      | 18          | P                      | A                  |

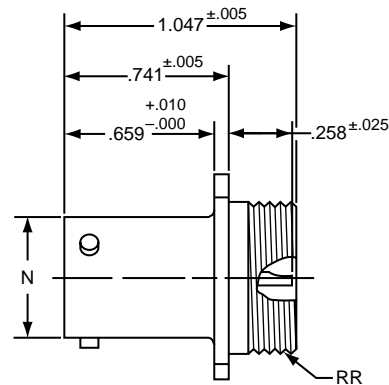
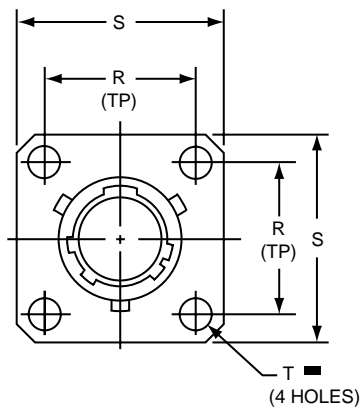

- \* LJT00H-XX-XXX
- \*\* LJT00Y-XX-XXX (MS27469YXXD)
- \*\*\* LJTS00Y-XX-XXX (MS27469YXXE)

■  $\text{⊕} \text{ } .005 \text{ DIA } \text{Ⓜ}$

- \* Long Junior Tri-Lock
- \*\* Interfacial seal wafer
- \*\*\* High temperature version, interfacial seal wafer with stainless steel shell

| Shell Size | N Dia. +.001<br>-.005 | R (TP) | S ±.016 | T Dia. ±.005 | RR Thread Class 2A |
|------------|-----------------------|--------|---------|--------------|--------------------|
| 9          | .572                  | .719   | .938    | .128         | .6875-24 UNEF      |
| 11         | .700                  | .812   | 1.031   | .128         | .8125-20 UNEF      |
| 13         | .850                  | .906   | 1.125   | .128         | .9375-20 UNEF      |
| 15         | .975                  | .969   | 1.219   | .128         | 1.0625-18 UNEF     |
| 17         | 1.100                 | 1.062  | 1.312   | .128         | 1.1875-18 UNEF     |
| 19         | 1.207                 | 1.156  | 1.438   | .128         | 1.3125-18 UNEF     |
| 21         | 1.332                 | 1.250  | 1.562   | .128         | 1.4375-18 UNEF     |
| 23         | 1.457                 | 1.375  | 1.688   | .147         | 1.5625-18 UNEF     |
| 25         | 1.582                 | 1.500  | 1.812   | .147         | 1.6875-18 UNEF     |

All dimensions for reference only.

# LJT07 (MS27470) Series I – Hermetic Jam Nut Receptacle

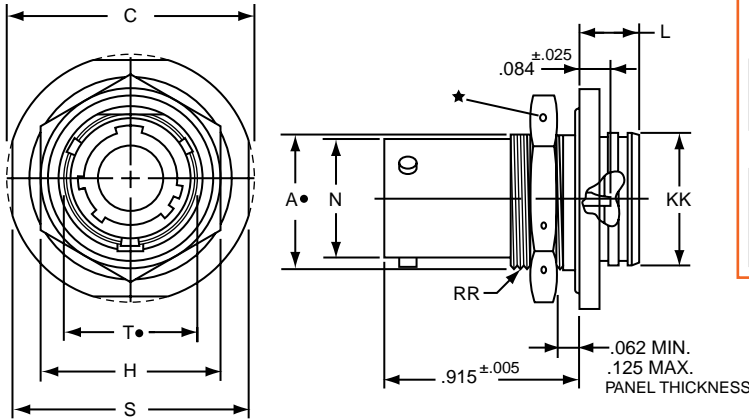

**PART #** Part number reference. To complete, see how to order pages 46-50.

| Connector Type | Shell Style | Service Class | Shell Size & Insert Arrg | Contact Type | Alternate Position | Special Variations |
|----------------|-------------|---------------|--------------------------|--------------|--------------------|--------------------|
| LJT/LJTS       | H           | RE            | 22-2                     | P            | A                  | (XXX)              |

**Military**

| MS Number | Service Class | Shell Size | Finish | Insert Arrg | Contact Style (P or S) | Alternate Position |
|-----------|---------------|------------|--------|-------------|------------------------|--------------------|
| MS27470   | Y             | 14         | A      | 18          | P                      | A                  |
| MS27471   | Y             | 14         | A      | 18          | P                      | A                  |

| Shell Size | A*<br>+.000<br>-.010 | C Max. | H Hex<br>+.017<br>-.016 | L Max. | N<br>+.000<br>-.005 | S<br>±.016 | T*<br>+.010<br>-.000 | KK<br>+.011<br>-.000 | RR Thread<br>Class 2A (Plated) |
|------------|----------------------|--------|-------------------------|--------|---------------------|------------|----------------------|----------------------|--------------------------------|
| 9          | .669                 | 1.199  | .875                    | .297   | .572                | 1.062      | .697                 | .642                 | .6875-24 UNEF                  |
| 11         | .769                 | 1.386  | 1.000                   | .297   | .700                | 1.250      | .822                 | .766                 | .8125-20 UNEF                  |
| 13         | .955                 | 1.511  | 1.188                   | .297   | .850                | 1.375      | 1.007                | .892                 | 1.0000-20 UNEF                 |
| 15         | 1.084                | 1.636  | 1.312                   | .297   | .975                | 1.500      | 1.134                | 1.018                | 1.1250-18 UNEF                 |
| 17         | 1.208                | 1.761  | 1.438                   | .297   | 1.100               | 1.625      | 1.259                | 1.142                | 1.2500-18 UNEF                 |
| 19         | 1.333                | 1.949  | 1.562                   | .328   | 1.207               | 1.812      | 1.384                | 1.268                | 1.3750-18 UNEF                 |
| 21         | 1.459                | 2.073  | 1.688                   | .328   | 1.332               | 1.938      | 1.507                | 1.392                | 1.5000-18 UNEF                 |
| 23         | 1.580                | 2.199  | 1.812                   | .328   | 1.457               | 2.062      | 1.634                | 1.518                | 1.6250-18 UNEF                 |
| 25         | 1.709                | 2.328  | 2.000                   | .328   | 1.582               | 2.188      | 1.759                | 1.642                | 1.7500-18 UNS                  |

All dimensions for reference only.

- \* LJT07H-XX-XXX
- \*\* LJT07Y-XX-XXX (MS27470YXXD)
- \*\*\* LJTS07Y-XX-XXX (MS27470YXXE)

- ★ .059 Dia. Min. 3 lockwire holes. Formed lockwire hole design (6 holes) is optional.
- "D" shaped mounting hole dimensions.
- \* \*Long Junior Tri-Lock
- \*\* Interfacial seal wafer
- \*\*\* High temperature version, interfacial seal wafer with stainless steel shell

# LJTI (MS27471) Series I – Hermetic Solder Mounting Receptacle

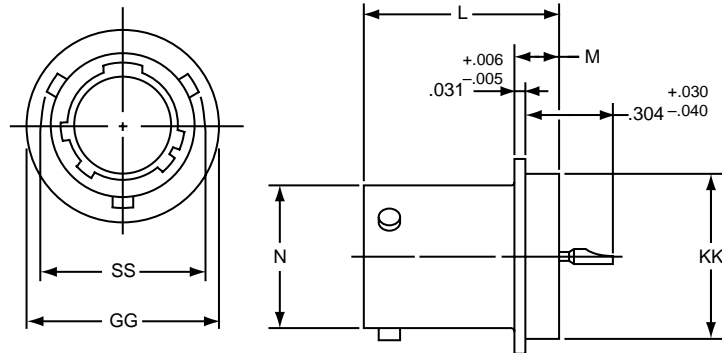

- \* Long Junior Tri-Lock
- \*\* Interfacial seal wafer
- \*\*\* High temperature version, interfacial seal wafer with stainless steel shell

| Shell Size | N Dia.<br>+.001<br>-.005 | SS Dia.<br>+.000<br>-.016 | L +.011<br>-.000 | M<br>+.006<br>-.005 | GG Dia.<br>+.011<br>-.010 | KK Dia.<br>+.001<br>-.005 |
|------------|--------------------------|---------------------------|------------------|---------------------|---------------------------|---------------------------|
| 9          | .572                     | .662                      | .789             | .125                | .750                      | .672                      |
| 11         | .700                     | .810                      | .789             | .125                | .844                      | .781                      |
| 13         | .850                     | .960                      | .789             | .125                | .969                      | .906                      |
| 15         | .975                     | 1.085                     | .789             | .125                | 1.094                     | 1.031                     |
| 17         | 1.100                    | 1.210                     | .789             | .125                | 1.218                     | 1.156                     |
| 19         | 1.207                    | 1.317                     | .789             | .125                | 1.312                     | 1.250                     |
| 21         | 1.332                    | 1.442                     | .789             | .125                | 1.438                     | 1.375                     |
| 23         | 1.457                    | 1.567                     | .821             | .156                | 1.563                     | 1.500                     |
| 25         | 1.582                    | 1.692                     | .821             | .156                | 1.688                     | 1.625                     |

- \* LJTIH-XX-XXX
- \*\* LJTIY-XX-XXX (MS27471YXXD)
- \*\*\* LJTSIY-XX-XXX (MS27471YXXE)

All dimensions for reference only.  
Weld mounting hermetic receptacle also available.  
Consult Amphenol, Sidney, NY for availability and dimensions.

- III 38999 SJT
- Matrix 2 26482
- Matrix Pyle 83723 III
- Crimp Rear Release Matrix 5015
- Pyle 26500 Pyle
- Printed Circuit Board
- EMI Filter Transient
- Fiber Optics
- High Speed Contacts
- Options Others

Military qualified to MIL-DTL-27599

**PART #** Part number reference. To complete, see how to order pages 46-50.

| Connector Type | Shell Style | Service Class | Shell Size & Insert Arrg | Contact Type | Alternate Position | Special Variations |
|----------------|-------------|---------------|--------------------------|--------------|--------------------|--------------------|
| LJT            | 00          | P             | 22-2                     | P            | A                  | (XXX)              |

**Military**

| MS Number | Service Class | Shell Size | Finish | Insert Arrg | Contact Style (P or S) | Alternate Position |
|-----------|---------------|------------|--------|-------------|------------------------|--------------------|
| MS20026   | T             | 14         | A      | 18          | P                      | A                  |
| MS20027   | T             | 14         | A      | 18          | P                      | A                  |

LJT00T-XX-XXX (MS20026T)

LJT00P-XX-XXX

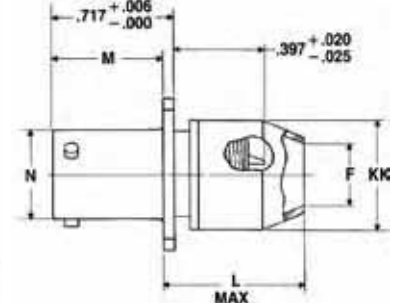
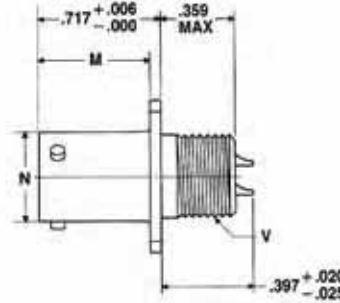
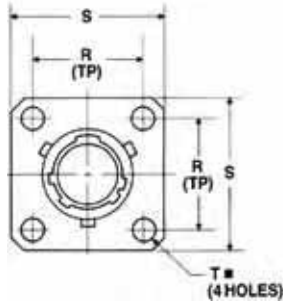

⊕ .005 DIA ⊙

NOTE: For availability of back panel mounting types, CHECK with nearest sales office or call Amphenol, Sidney, NY.

| Shell Size | F Dia. | L Max. | M +.000 - .005 | N +.001 - .005 | R (TP) | S ±.016 | T Dia. ±.005 | VThread Class 2A UNEF (Plated) | KK Dia. Max. |
|------------|--------|--------|----------------|----------------|--------|---------|--------------|--------------------------------|--------------|
| 9          | .327   | .625   | .632           | .572           | .719   | .938    | .128         | .4375-28                       | .608         |
| 11         | .444   | .625   | .632           | .700           | .812   | 1.031   | .128         | .5625-24                       | .734         |
| 13         | .558   | .625   | .632           | .850           | .906   | 1.125   | .128         | .6875-24                       | .858         |
| 15         | .683   | .625   | .632           | .975           | .969   | 1.219   | .128         | .8125-20                       | .984         |
| 17         | .808   | .625   | .632           | 1.100          | 1.062  | 1.312   | .128         | .9375-20                       | 1.110        |
| 19         | .909   | .625   | .632           | 1.207          | 1.156  | 1.438   | .128         | 1.0625-18                      | 1.234        |
| 21         | 1.034  | .703   | .602           | 1.332          | 1.250  | 1.562   | .128         | 1.1875-18                      | 1.360        |
| 23         | 1.159  | .703   | .602           | 1.457          | 1.375  | 1.688   | .147         | 1.3125-18                      | 1.484        |
| 25         | 1.284  | .703   | .602           | 1.582          | 1.500  | 1.812   | .147         | 1.4375-18                      | 1.610        |

## LJT01 (MS20027) Series I – Solder Line Receptacle

Military qualified to MIL-DTL-27599

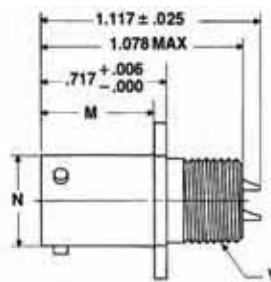
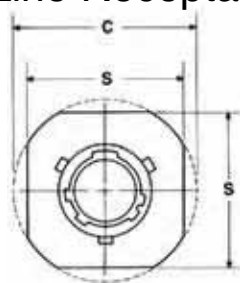

LJT01T-XX-XXX (MS20027T)

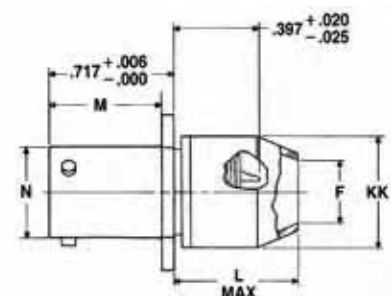

LJT01P-XX-XXX

| Shell Size | C Max. | F Dia. | L Max. | M +.000 - .005 | N +.001 - .005 | S ±.016 | VThread Class 2A UNEF (Plated) | KK Dia. Max. |
|------------|--------|--------|--------|----------------|----------------|---------|--------------------------------|--------------|
| 9          | 1.094  | .327   | .625   | .632           | .572           | .938    | .4375-28                       | .608         |
| 11         | 1.188  | .444   | .625   | .632           | .700           | 1.031   | .5625-24                       | .734         |
| 13         | 1.281  | .558   | .625   | .632           | .850           | 1.125   | .6875-24                       | .858         |
| 15         | 1.375  | .683   | .625   | .632           | .975           | 1.219   | .8125-20                       | .984         |
| 17         | 1.469  | .808   | .625   | .632           | 1.100          | 1.312   | .9375-20                       | 1.110        |
| 19         | 1.594  | .909   | .625   | .632           | 1.207          | 1.438   | 1.0625-18                      | 1.234        |
| 21         | 1.719  | 1.034  | .703   | .602           | 1.332          | 1.562   | 1.1875-18                      | 1.360        |
| 23         | 1.844  | 1.159  | .703   | .602           | 1.457          | 1.688   | 1.3125-18                      | 1.484        |
| 25         | 1.969  | 1.284  | .703   | .602           | 1.582          | 1.812   | 1.4375-18                      | 1.610        |

All dimensions for reference only.

# LJT06 (MS20028) Series I – Solder Straight Plug

**Military qualified to MIL-DTL-27599**

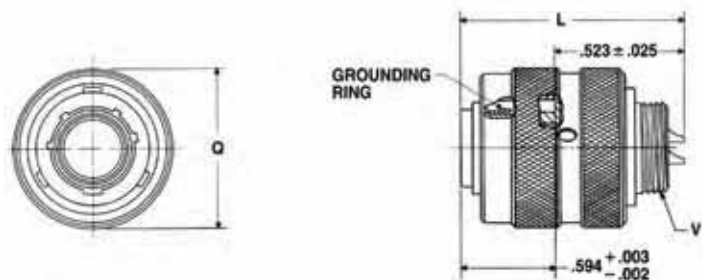

**PART #** Part number reference. To complete, see how to order pages 46-50.

| Connector Type | Shell Style | Service Class | Shell Size & Insert Arrg | Contact Type | Alternate Position | Special Variations |
|----------------|-------------|---------------|--------------------------|--------------|--------------------|--------------------|
| LJT            | 06          | T             | 22-2                     | P            | A                  | (XXX)              |

**Military**

| MS Number | Service Class | Shell Size | Finish | Insert Arrg | Contact Style (P or S) | Alternate Position |
|-----------|---------------|------------|--------|-------------|------------------------|--------------------|
| MS20028   | T             | 14         | A      | 18          | P                      | A                  |
| MS20029   | T             | 14         | A      | 18          | P                      | A                  |

**LJT06T-XX-XXX (MS20028T)**

| Shell Size | F Dia. | L Max. | L' Max. | Q Max. | VThread Class 2A UNEF (Plated) | KK Dia. Max. |
|------------|--------|--------|---------|--------|--------------------------------|--------------|
| 9          | .327   | 1.128  | 1.488   | .844   | .4375-28                       | .608         |
| 11         | .444   | 1.128  | 1.488   | .969   | .5625-24                       | .734         |
| 13         | .558   | 1.128  | 1.488   | 1.141  | .6875-24                       | .858         |
| 15         | .683   | 1.128  | 1.488   | 1.266  | .8125-20                       | .984         |
| 17         | .808   | 1.128  | 1.488   | 1.391  | .9375-20                       | 1.110        |
| 19         | .909   | 1.128  | 1.488   | 1.500  | 1.0625-18                      | 1.234        |
| 21         | 1.034  | 1.128  | 1.566   | 1.625  | 1.1875-18                      | 1.360        |
| 23         | 1.159  | 1.128  | 1.566   | 1.750  | 1.3125-18                      | 1.484        |
| 25         | 1.284  | 1.191  | 1.644   | 1.875  | 1.4375-18                      | 1.610        |

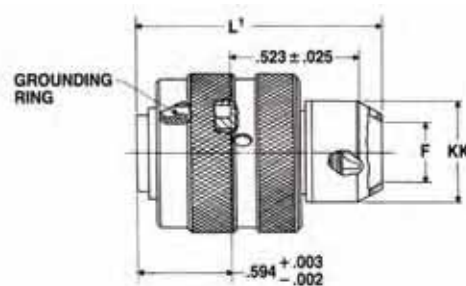

**LJT06P-XX-XXX**

# LJT07 (MS20029) Series I – Solder Jam Nut Receptacle

**Military qualified to MIL-DTL-27599**

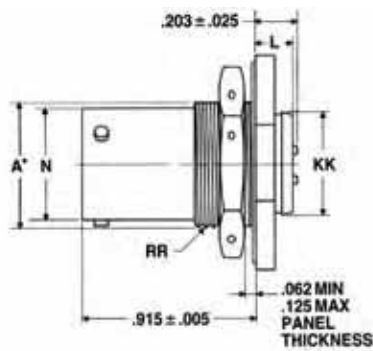
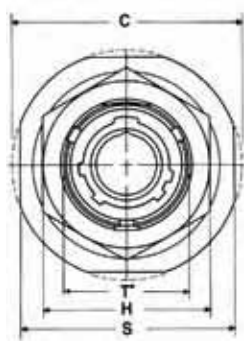

**LJT07T-XX-XXX (MS20029T)**

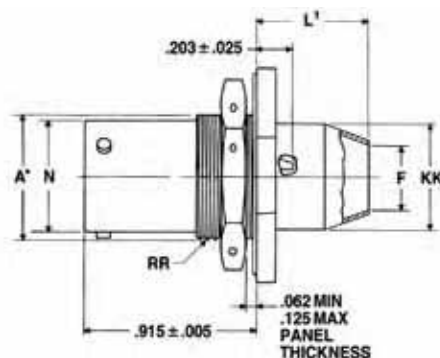

**LJT07P-XX-XXX (MS20029P)**

• "D" shaped mounting hole dimensions

| Shell Size | A* +.000 / -.010 | C Max. | F Dia. | H Hex +.017 / -.016 | L Max. | L' Max. | N +.001 / -.005 | S ±.016 | T* +.010 / -.000 | KK +.011 / -.000 | KK' Dia. Max. | RR Thread Class 2A (Plated) |
|------------|------------------|--------|--------|---------------------|--------|---------|-----------------|---------|------------------|------------------|---------------|-----------------------------|
| 9          | .669             | 1.199  | .327   | .875                | .234   | .625    | .572            | 1.062   | .697             | .516             | .608          | .6875-24UNEF                |
| 11         | .769             | 1.386  | .444   | 1.000               | .234   | .625    | .700            | 1.250   | .822             | .642             | .734          | .8125-20UNEF                |
| 13         | .955             | 1.511  | .558   | 1.188               | .234   | .625    | .850            | 1.375   | 1.007            | .766             | .858          | 1.0000-20UNEF               |
| 15         | 1.084            | 1.636  | .683   | 1.312               | .234   | .625    | .975            | 1.500   | 1.134            | .892             | .984          | 1.1250-18UNEF               |
| 17         | 1.208            | 1.761  | .808   | 1.438               | .234   | .625    | 1.100           | 1.625   | 1.259            | 1.018            | 1.110         | 1.2500-18UNEF               |
| 19         | 1.333            | 1.949  | .909   | 1.562               | .266   | .625    | 1.207           | 1.812   | 1.384            | 1.142            | 1.234         | 1.3750-18UNEF               |
| 21         | 1.459            | 2.073  | 1.034  | 1.688               | .266   | .656    | 1.332           | 1.938   | 1.507            | 1.268            | 1.360         | 1.5000-18UNEF               |
| 23         | 1.580            | 2.199  | 1.159  | 1.812               | .266   | .750    | 1.457           | 2.062   | 1.634            | 1.392            | 1.484         | 1.6250-18UNEF               |
| 25         | 1.709            | 2.323  | 1.284  | 2.000               | .266   | .750    | 1.582           | 2.188   | 1.759            | 1.518            | 1.610         | 1.7500-18UNS                |

All dimensions for reference only.

38999  
SJT

26482  
Matrix 2

83723 III  
Matrix Pyle

5015  
Crimp Rear Release Matrix

26500 Pyle

Printed  
Circuit Board

EMI Filter  
Transient

Fiber Optics

High Speed  
Contacts

Options  
Others

## INSERT AVAILABILITY

| Shell Size / Insert Arrangement | Service Rating | Total Contacts | Contact Size |    |    |    |         |         |          |   |
|---------------------------------|----------------|----------------|--------------|----|----|----|---------|---------|----------|---|
|                                 |                |                | 22D          | 20 | 16 | 12 | 12 Coax | 8 Coax* | 8 Twinax |   |
| 11-2                            | I              | 2              |              |    | 2  |    |         |         |          |   |
| 11-35                           | M              | 13             | 13           |    |    |    |         |         |          |   |
| 11-98                           | I              | 6              |              | 6  |    |    |         |         |          |   |
| 13-4                            | I              | 4              |              |    | 4  |    |         |         |          |   |
| 13-8                            | I              | 8              |              | 8  |    |    |         |         |          |   |
| 13-35                           | M              | 22             | 22           |    |    |    |         |         |          |   |
| 13-98                           | I              | 10             |              | 10 |    |    |         |         |          |   |
| 15-5                            | II             | 5              |              |    | 5  |    |         |         |          |   |
| 15-15                           | I              | 15             |              | 14 | 1  |    |         |         |          |   |
| 15-18                           | I              | 18             |              | 18 |    |    |         |         |          |   |
| 15-19                           | I              | 19             |              | 19 |    |    |         |         |          |   |
| 15-35                           | M              | 37             | 37           |    |    |    |         |         |          |   |
| 15-97                           | I              | 12             |              | 8  | 4  |    |         |         |          |   |
| 17-6                            | I              | 6              |              |    |    | 6  |         |         |          |   |
| 17-8                            | II             | 8              |              |    | 8  |    |         |         |          |   |
| 17-26                           | I              | 26             |              | 26 |    |    |         |         |          |   |
| 17-35                           | M              | 55             | 55           |    |    |    |         |         |          |   |
| 17-99                           | I              | 23             |              | 21 | 2  |    |         |         |          |   |
| 19-11                           | II             | 11             |              |    | 11 |    |         |         |          |   |
| 19-32                           | I              | 32             |              | 32 |    |    |         |         |          |   |
| 19-35                           | M              | 66             | 66           |    |    |    |         |         |          |   |
| 21-11                           | I              | 11             |              |    |    | 11 |         |         |          |   |
| 21-16                           | II             | 16             |              |    | 16 |    |         |         |          |   |
| 21-35                           | M              | 79             | 79           |    |    |    |         |         |          |   |
| 21-39                           | I              | 39             |              | 37 | 2  |    |         |         |          |   |
| 21-41                           | I              | 41             |              | 41 |    |    |         |         |          |   |
| 23-21                           | II             | 21             |              |    | 21 |    |         |         |          |   |
| 23-35                           | M              | 100            | 100          |    |    |    |         |         |          |   |
| 23-53                           | I              | 53             |              | 53 |    |    |         |         |          |   |
| 23-54                           | M              | 53             | 40           |    | 9  | 4  |         |         |          |   |
| 23-55                           | I              | 55             |              | 55 |    |    |         |         |          |   |
| 25-4                            | I              | 56             |              | 48 | 8  |    |         |         |          |   |
| 25-19                           | I              | 19             |              |    |    | 19 |         |         |          |   |
| 25-20                           | N              | 30             |              | 10 | 13 |    | 4       |         |          | 3 |
| 25-24                           | I              | 24             |              |    | 12 | 12 |         |         |          |   |
| 25-29                           | I              | 29             |              |    | 29 |    |         |         |          |   |
| 25-35                           | M              | 128            | 128          |    |    |    |         |         |          |   |
| 25-43                           | I              | 43             |              | 23 | 20 |    |         |         |          |   |
| 25-46                           | I              | 46             |              | 40 | 4  |    |         |         | 2*       |   |
| 25-61                           | I              | 61             |              | 61 |    |    |         |         |          |   |

### LJT Lanyard Separation Forces

| Shell Size                 | Straight Plug (lbs. max.) | 15 Degree Pull (lbs. Max.) |
|----------------------------|---------------------------|----------------------------|
| 11<br>13<br>15             | 45                        | 55                         |
| 17<br>19<br>21<br>23<br>25 | 90                        | 100                        |

\* For RG 180/U and RG 195/U cables only. (Check Amphenol Aerospace, Sidney, NY for other cable applications). For availability of other insert arrangements and accessories consult Amphenol Aerospace.

## TABLE I INSERT ARRANGEMENT CODE

| Basic Part Number | MIL-DTL-38999 Insert Arrangement |
|-------------------|----------------------------------|
| 88/91-538808      | 11-2                             |
| 06                | 11-35                            |
| 07                | 11-98                            |
| 10                | 13-4                             |
| 11                | 13-8                             |
| 13                | 13-98                            |
| 14                | 13-35                            |
| 18                | 15-5                             |
| 23                | 15-15                            |
| 22                | 15-18                            |
| 19                | 15-19                            |
| 20                | 15-35                            |
| 27                | 17-6                             |
| 28                | 17-8                             |
| 29                | 17-26                            |
| 30                | 17-35                            |
| 31                | 17-99                            |
| 37                | 19-11                            |
| 39                | 19-32                            |
| 40                | 19-35                            |
| 47                | 21-11                            |
| 48                | 21-16                            |
| 49                | 21-35                            |
| 50                | 21-41                            |
| 51                | 21-39                            |
| 57                | 23-21                            |
| 58                | 23-35                            |
| 59                | 23-53                            |
| 61                | 23-54                            |
| 60                | 23-55                            |
| 66                | 25-19                            |
| 74                | 25-20                            |
| 67                | 25-29                            |
| 68                | 25-35                            |
| 69                | 25-43                            |
| 70                | 25-61                            |
| 71                | 25-46                            |
| 72                | 25-2                             |
| 74                | 25-4                             |

## TABLE II LANYARD LENGTH CODES

| Lanyard Length (in.) ±.250 | MS     | Commercial Code |
|----------------------------|--------|-----------------|
| 4.000                      |        | 40              |
| 4.250                      |        | 41              |
| 4.500                      |        | 42              |
| 4.750                      |        | 43              |
| 5.000                      |        | 50              |
| 5.250                      |        | 51              |
| 5.500                      |        | 52              |
| 5.750                      |        | 53              |
| 6.000                      | No     | 60              |
| 6.250                      | Code   | 61              |
| 6.500                      |        | 62              |
| 6.750                      | Std.   | 63              |
| 7.000                      | Length | 70              |
| 7.250                      | 6.250  | 71              |
| 7.500                      |        | 72              |
| 7.750                      |        | 73              |
| 8.000                      |        | 80              |
| 8.250                      |        | 81              |
| 8.500                      |        | 82              |
| 8.750                      |        | 83              |
| 9.000                      |        | 90              |
| 9.250                      |        | 91              |
| 9.500                      |        | 92              |
| 9.750                      |        | 93              |



# Series I, LJT Breakaway Fail Safe Lanyard Release Plug How to Order, cont.

III 38999  
II 1 SJT  
I 26482 Matrix 2  
83723 III Matrix Pyle  
5015 Crimp Rear Release Matrix  
26500 Pyle  
Printed Circuit Board  
EMI Filter Transient  
Fiber Optics  
High Speed Contacts  
Options Others

## HOW TO ORDER - BY MILITARY PART NUMBER FAIL SAFE MS27661

- 1.
- 2.
- 3.
- 4.
- 5.
- 6.
- 7.

| MS Number | Service Class | Shell Size | Finish | Insert Arrg. | Contact Style | Alternate Position |
|-----------|---------------|------------|--------|--------------|---------------|--------------------|
| MS27661   | T             | 17         | B      | 35           | P             | A                  |

### 1. MS27661 Number

MS Number designates MIL-DTL-38999, Series I LJT Lanyard Release Plug

### 2. Select a Service Class

|          |   |
|----------|---|
| <b>E</b> | For environmental crimp applications (inactive for new design)                |
| <b>T</b> | For environmental crimp applications with serrations on rear threads of shell |

### 3. Select a Shell Size

MIL-DTL-38999, sizes 11 through 25, see chart on page 78.

### 4. Select a Finish

|          |   |
|----------|---|
| <b>B</b> | Designates corrosion resistant olive drab cadmium plated aluminum, 500 hour extended salt spray, EMI shielding effectiveness -50dB @ 10 GHz specification min., 175°C |
| <b>F</b> | Designates electroless nickel plated aluminum, 48 hour salt spray, EMI shielding effectiveness -65dB @ 10 GHz 500 specification min., 200°C                           |

These are standard finishes. Consult Amphenol Aerospace for variations.

### 5. Select an Insert Arrangement

MIL-DTL-38999, see insert identification chart on page 78.

### 6. Select a Contact Style

|          |  |
|----------|--|
| <b>P</b> | Designates Lanyard Release plug with pin contacts    |
| <b>S</b> | Designates Lanyard Release plug with socket contacts |

### 7. Alternate Keying Position

For alternate Position of connector (to prevent cross-mating) see LJT key/keyway rotation below. (No letter is required for normal)

#### LJT Key/Keyway Rotation

| Shell Size | AB ANGLE OF ROTATION (Degrees) |     |     |      |      |
|------------|--------------------------------|-----|-----|------|------|
|            | Normal                         | A   | B   | C    | D    |
| 9          | 95°                            | 77° | -   | -    | 113° |
| 11         | 95°                            | 81° | 67° | 123° | 109° |
| 13         | 95°                            | 75° | 63° | 127° | 115° |
| 15         | 95°                            | 74° | 61° | 129° | 116° |
| 17         | 95°                            | 77° | 65° | 125° | 113° |
| 19         | 95°                            | 77° | 65° | 125° | 113° |
| 21         | 95°                            | 77° | 65° | 125° | 113° |
| 23         | 95°                            | 80° | 69° | 121° | 110° |
| 25         | 95°                            | 80° | 69° | 121° | 110° |

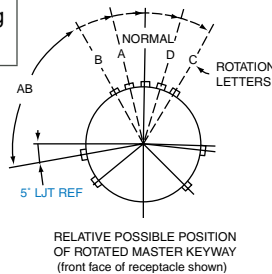

## HOW TO ORDER - BY COMMERCIAL PART NUMBER FAIL SAFE 88-5388 OR 91-5388

- 1.
- 2.
- 3.
- 4.
- 5.

| Finish | Connector Type Identification | Shell Size & Insert Arrangement | Lanyard Length Code | Contact Type Alternate Rotation of Insert |
|--------|-------------------------------|---------------------------------|---------------------|---|
| 88     | 5388                          | 29                              | 40                  | P   |

### 1. Select a Finish

|           |   |
|-----------|---|
| <b>88</b> | Designates corrosion resistant olive drab cadmium plate over nickel, 500 hour extended salt spray, EMI -50dB @ 10 GHz specification min., 175°C |
| <b>91</b> | Designates electroless nickel plated aluminum, optimum EMI shielding effectiveness -65dB @ 10 GHz specification min., 48 hour salt spray, 200°C |

These are standard finishes. Consult Amphenol Aerospace, Sidney, NY for variations.

### 2. Connector Type Identification

|             |   |
|-------------|---|
| <b>5388</b> | Designates MIL-DTL-38999, Series I LJT Lanyard Release Plug |
|-------------|---|

### 3. Select a Shell Size and Insert Arrangement

Shell sizes are MIL-DTL-38999, Series III from sizes 11 thru 25. The basic part number selected specifies the insert arrangement. See Table I (page 78) for coded part number that correlates to insert arrangement.

### 4. Select a Lanyard Length Code

See Table II (page 78) for lanyard length code number.

### 5. Select a Contact Type/Alternate Rotation of Insert

|          |  |
|----------|--|
| <b>P</b> | Designates Lanyard Release plug with pin contacts    |
| <b>S</b> | Designates Lanyard Release plug with socket contacts |

When an alternate position of the connector is required to prevent cross-mating, a different letter (other than P or S) is used. See alternate positioning for LJT (to your left), then convert to Amphenol commercial coding by the following chart below.

| Pin Contacts |                 | Socket Contacts |                 |
|--------------|-----------------|-----------------|-----------------|
| MS Letter    | Amphenol Letter | MS Letter       | Amphenol Letter |
| P            | P (normal)      | S               | S (normal)      |
| PA           | E               | SA              | F               |
| PB           | R               | SB              | T               |
| PC           | W               | SC              | X               |
| PD           | Y               | SD              | Z               |

Amphenol LJT Breakaway Fail Safe Connectors provide unequaled performance in environments requiring instant disengagement.

Designed to provide quick disconnect of a connector plug and receptacle with an axial pull on the lanyard, the "Breakaway" Fail Safe connector family offers a wide range of electrical and mechanical features:

- Instant decoupling and damage free separation
- Completely intermateable with standard LJT receptacles
- Inventory support commonality through the use of standard insert arrangements and contacts

Breakaway un-mating is initiated by applying a pull force to the lanyard which causes the operating sleeve on the plug to move away from the receptacle. Coupling segments on the plug then move away from the mating receptacle while expanding, thus releasing the receptacle. After completion of the un-mating sequence, spring compression returns the sleeve and segments to their original positions. Un-mating of the plug may also be accomplished by normal rotation of the coupling ring without affecting the breakaway capability.

The LJT Breakaway Fail Safe connector features which provide EMI EMP shielding in excess of MIL-DTL-38999 Series I requirements:

- Solid metal-to-metal coupling
- EMI grounding fingers
- Conductive finishes

Contact Amphenol Aerospace for more information on breakaway, quick-disconnect connectors. Other Amphenol cylindrical families (MIL-DTL-38999 Series III, MIL-DTL-26482, MIL-DTL-83723) also offer breakaway quick-disconnect connectors.

**PART #** Part number reference. To complete, see how to order pages 79.

| Connector Type | Shell Style | Service Class | Shell Size & Insert Arrg | Contact Type | Alternate Position | Special Variations |
|----------------|-------------|---------------|--------------------------|--------------|--------------------|--------------------|
| 88/91          | 5388        | T             | 22-2                     | P            | A                  | (XXX)              |

**Military**

| MS Number | Service Class | Shell Size | Finish | Insert Arrg | Contact Style (P or S) | Alternate Position |
|-----------|---------------|------------|--------|-------------|------------------------|--------------------|
| MS27661   | T             | 14         | A      | 18          | P                      | A                  |

### LJT Fail Safe 88-5388/91-5388 (MS27661)

#### Lanyard Release Plug

\* To complete order number see page 79.

| Shell Size | A Dia. Max. | B Max. | D Max. Accessory Dia. | L Max. | V Thread UNEF Class 2A (Plated) |
|------------|-------------|--------|-----------------------|--------|---------------------------------|
| 11         | 1.393       | 1.797  | .740                  | 1.703  | .5625-24                        |
| 13         | 1.558       | 1.969  | .926                  | 1.703  | .6875-24                        |
| 15         | 1.669       | 2.078  | 1.051                 | 1.703  | .8125-20                        |
| 17         | 1.797       | 2.203  | 1.176                 | 1.703  | .9375-20                        |
| 19         | 1.926       | 2.323  | 1.300                 | 1.703  | 1.0625-18                       |
| 21         | 2.054       | 2.469  | 1.426                 | 1.703  | 1.1875-18                       |
| 23         | 2.183       | 2.594  | 1.551                 | 1.703  | 1.3125-18                       |
| 25         | 2.293       | 2.703  | 1.676                 | 1.766  | 1.4375-18                       |

All dimensions for reference only.

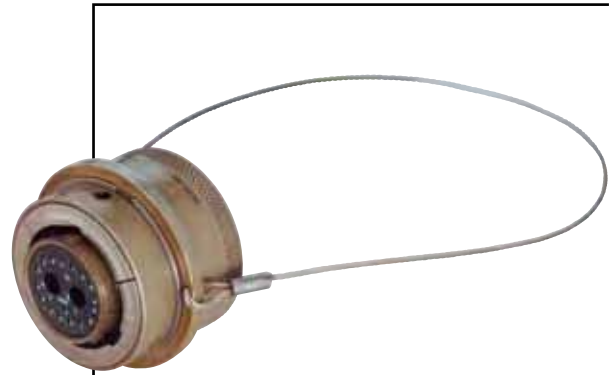

### LJT Breakaway Fail Safe

In addition to standard Breakaway connectors, Amphenol also manufactures custom breakaway connectors including those with:

- Increased pull-force capability
- Custom lanyard lengths and backshells
- Low force separation capabilities
- Low insertion/separation force contacts
- Non-cadmium finishes
- Custom JT Series Breakaway designs have been developed for special applications; however the LJT Series is recommended over the JT Series for the quick-disconnect breakaway style.

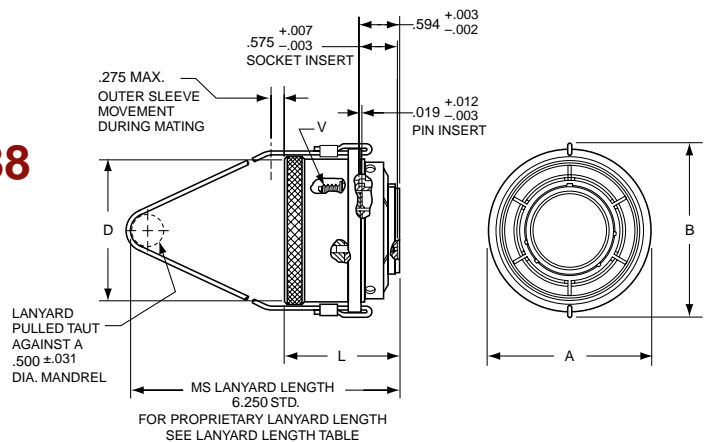

38999 SJT I II III  
26482 Matrix 2  
83723 III Matrix Pyle  
5015 Crimp Rear Release Matrix  
26500 Pyle  
Printed Circuit Board  
EMI Filter Transient  
Fiber Optics  
High Speed Contacts  
Options Others

# Amphenol SJT Series



## TABLE OF CONTENTS

### Amphenol SJT Connectors -

#### Scoop-Proof Design of LJT Series & Standard Mounting Dimensions of JT Series - Meet European Specification Applications

|  |    |
|--|----|
| • Table of Contents . . . . .                      | 81 |
| • Features, Specifications . . . . .               | 82 |
| • How to Order, Alternate Rotations . . . . .      | 83 |
| • Insert Availability and Identification . . . . . | 84 |

### SJT Shell Styles:

|   |        |
|---|--------|
| • Crimp Wall Mounting Receptacle SJT00RT,<br>Crimp Wall Mounting Receptacle for Back Panel Mounting SJTP00RT    | 85     |
| • Crimp Box Mounting Receptacle for Back Panel Mounting SJTP02RE,<br>Crimp Jam Nut Receptacle SJT07RT . . . . . | 86     |
| • Crimp Straight Plug SJT06RT,<br>Crimp Straight Plug with Grounding Fingers SJTG06RT . . . . .                 | 87     |
| • Hermetic Solder Mounting Receptacle SJTIY,<br>Hermetic Jam Nut Receptacle SJT07Y . . . . .                    | 88     |
| • Accessories, Contacts, and Tools see pages . . . . .  | 89-108 |



### SJT Typical Markets:

- Military & Commercial Aviation (older designs)
- Applications Complaint with European Specifications:  
PAN6433-2, LN29729, VG96912
- Military Vehicles



Amphenol® SJT connectors combine unique design features of the scoop-proof LJT series within standard mounting dimensions of JT types. Available in a wide range of shell sizes, finishes, insert arrangements and accessories, the SJT features:



- **100% scoop-proof design** – basic MIL-DTL-38999 Series I\* lengths
- **Standard mounting dimensions** – MIL-DTL-38999, Series III\*\* dimensions
- **Compliance with European Specifications** – PAN6433-2, LN29729, VG96912

### Components

Standard connectors use aluminum shells. Standard plating on shell components is cadmium over nickel with many optional finishes available. A dependable 5-key/keyway shell polarization with bayonet-lock coupling is incorporated to aid and assure positive mating.

The insert material is a high-temperature, rigid dielectric polymer providing excellent electrical characteristics. A fluorinated silicone interfacial seal is featured on the mating face of the pin inserts, assuring complete electrical isolation of the pins when connector halves are mated. Contrasting letter or number designations are used on the insert faces. A main joint gasket is installed in the receptacles for moisture sealing between connector halves.

Serrated and threaded shells, with a moisture sealing pilot for back shells, accept a wide range of accessories.

Hermetic seal receptacles are available in carbon steel or stainless steel shells.

### Contacts

Rear insertable/rear release crimp contacts are standard in SJT connectors. Power contacts are available in sizes 10, 12, 16, 20, 22M and 22D. All socket contacts are probe proof. Standard contact plating is 50 mμ minimum gold. Coaxial contacts are available in sizes 8, 12 and 16 to accommodate a wide range of coaxial cables; see Coaxial contact information in the High Speed Contact section of this catalog. Size 8 and 12 Twinax contacts are also available; see Concentric Twinax contact information in the High Speed Contact section of this catalog.

### Optional Features

Special adaptations of the SJT are available for hermetic and high temperature applications. The SJTS high temperature connector is rated at 392°F. SJT hermetic receptacles are described on page 88.

### Specials

Special types are available, such as connectors less contacts and circular rack and panel connectors with solderless wrap contacts. A complete listing of connector types, shell styles and service classes appears on page 83, How to Order. For further information on special application requirements, contact an Amphenol Sales Person or visit [www.amphenol-aerospace.com/support](http://www.amphenol-aerospace.com/support) to find a sales person in your area.

\*MIL-DTL-38999 Series I supersedes MIL-C-38999 Series I.

\*\*MIL-DTL-38999 Series III supersedes MIL-C-38999 Series III.

### CONTACT RATING

| Contact Size | Test Current |          | Maximum Millivolt Drop Crimp* | Maximum Millivolt Drop Hermetic | Contact Size | Crimp Well Data |                 |
|--------------|--------------|----------|-------------------------------|---------------------------------|--------------|-----------------|-----------------|
|              | Standard     | Hermetic |                               |                                 |              | Well Diameter   | Min. Well Depth |
| 22M          | 3            | 2        | 45                            | 60                              | 22M          | .028 ±.001      | .141            |
| 22D          | 5            | 3        | 73                            | 85                              | 22D          | .0345 ±.0010    | .141            |
| 22           | 5            | 3        | 73                            | 85                              | 22           | .0365 ±.0010    | .141            |
| 20           | 7.5          | 5        | 55                            | 60                              | 20           | .047 ±.001      | .209            |
| 16           | 13           | 10       | 49                            | 85                              | 16           | .067 ±.001      | .209            |
| 12           | 23           | 17       | 42                            | 85                              | 12           | .100 ±.002      | .209            |
| 10 Power     | 33           | NA       | 33                            | NA                              | 10 (Power)   | .137 ±.002      | .355            |

\* When using silver plated wire

### SERVICE RATING\*\*

| Service Rating | Suggested Operating Voltage (Sea Level) |      | Test Voltage (Sea Level) | Test Voltage 50,000 Ft. | Test Voltage 70,000 Ft. | Test Voltage 110,000 Ft. |
|----------------|---|------|--------------------------|-------------------------|-------------------------|--------------------------|
|                | AC (RMS)                                | DC   |                          |                         |                         |                          |
| M              | 400                                     | 550  | 1300 VRMS                | 550 VRMS                | 350 VRMS                | 200 VRMS                 |
| N              | 300                                     | 450  | 1000 VRMS                | 400 VRMS                | 260 VRMS                | 200 VRMS                 |
| I              | 600                                     | 850  | 1800 VRMS                | 600 VRMS                | 400 VRMS                | 200 VRMS                 |
| II             | 900                                     | 1250 | 2300 VRMS                | 800 VRMS                | 500 VRMS                | 200 VRMS                 |

\*\* Please note that the establishment of electrical safety factors is left entirely in the designer's hands, since he is in the best possible position to know what peak voltage, switching surges, transients, etc., can be expected in a particular circuit.

- 38999 SJT
- 26482 Matrix 2
- 83723 III Matrix Pyle
- 5015 Crimp Rear Release Matrix
- 26500 Pyle
- Printed Circuit Board
- EMI Filter Transient
- Fiber Optics
- High Speed Contacts
- Options Others



### Easy Steps to build a part number... SJT

- 1.
- 2.
- 3.
- 4.
- 5.
- 6.
- 7.

| Connector Type<br>SJT | Shell Style | Service Class | Shell Size-<br>Insert Arrangement. | Contact Type | Alternate Keying<br>Position | Finish<br>Variations Suffix |
|-----------------------|-------------|---------------|------------------------------------|--------------|------------------------------|-----------------------------|
| <b>SJT</b>            | <b>00</b>   | <b>RT</b>     | <b>18-66</b>                       | <b>P</b>     | <b>A</b>                     | <b>(XXX)</b>                |

#### Step 1. Select a Connector Type

|             | Designates                                     |
|-------------|--|
| <b>SJT</b>  | Standard scoop-proof Junior Tri-Lock Connector |
| <b>SJTS</b> | High Temperature Connector                     |
| <b>SJTG</b> | Plug with Grounding Fingers                    |
| <b>SJTP</b> | Back Panel Mounted                             |

#### Step 2. Select a Shell Style

|           | Designates                         |
|-----------|------------------------------------|
| <b>00</b> | Wall Mount Receptacle              |
| <b>06</b> | Straight Plug                      |
| <b>07</b> | Jam Nut Receptacle                 |
| <b>I</b>  | Solder Mount Receptacle – Hermetic |

#### Step 3. Select a Service Class

|           | Designates  |
|-----------|---|
| <b>Y</b>  | For hermetic applications. . . Fused compression glass sealed inserts. Leakage rate less than $1.0 \times 10^{-6}$ cc/sec. at 15 psi differential; with interfacial seal. |
| <b>RT</b> | For environmental applications – supplied without rear accessories. Design provides serrations on rear threads of shells with moisture sealing pilot for back shells.     |

For additional information defining complete description of service class, consult Amphenol, Sidney, NY.

#### Step 4. Select a Shell Size & Insert Arrangement from chart on pg. 84. To view Insert Arrangement illustrations see pgs. 8-12.

Shell Size & Insert Arrangements are together in one chart. First number represents Shell Size, second number is the Insert Arrangement. Only selected illustrations are available for SJT on pages 8-12. Please refer to chart on page 84 for select Insert Arrangements.

#### Step 5. Select a Contact Type

|          | Designates      |
|----------|-----------------|
| <b>P</b> | Pin Contacts    |
| <b>S</b> | Socket Contacts |

#### Step 6. Select an Alternate Keying Position

A plug with a given rotation letter will mate with a receptacle with the same rotation letter. The AB angle for a given connector is the same whether it contains pins or sockets. Inserts are not rotated in conjunction with the master key/keyway. AB angles shown are viewed from the front face of the connector. A receptacle is shown below. The angles for the plug are exactly the same, except the direction of rotation is opposite of that shown for the receptacle.

**Key/Keyway Rotation  
AB ANGLE OF ROTATION (Degrees)**

| Shell Size | Normal | A  | B  | C   | D   |
|------------|--------|----|----|-----|-----|
| 8          | 95     |    |    |     |     |
| 10         | 95     | 81 | 67 | 123 | 109 |
| 12         | 95     | 75 | 63 | 127 | 115 |
| 14         | 95     | 74 | 61 | 129 | 116 |
| 16         | 95     | 77 | 65 | 125 | 113 |
| 18         | 95     | 77 | 65 | 125 | 113 |
| 20         | 95     | 77 | 65 | 125 | 113 |
| 22         | 95     | 80 | 69 | 121 | 110 |
| 24         | 95     | 80 | 69 | 121 | 110 |

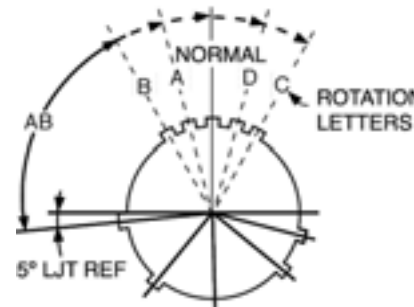

**RELATIVE POSSIBLE  
POSITION OF  
ROTATED MASTER  
KEYWAY  
(front face of  
receptacle shown)**

#### Step 7. Select a Finish Variation Suffix

**FINISH DATA**

| Aluminum Shell Components Non-Hermetic            |                  |   |
|---|------------------|---|
| Finish  | Suffix           | Indicated Finish Standard for SJT Types |
| Bright Cadmium Plated Nickel Base                 |                  | <b>SJT/SJTG</b>                         |
| Anodic Coating (Alumilite)                        | <b>(005)</b>     |   |
| Chromate Treated (Iridite 14-2)                   | <b>(011)</b>     |   |
| Olive Drab Cadmium Plate Nickel Base              | <b>(014)</b>     |   |
| Electroless Nickel Coating                        | <b>(023)</b>     |   |
| Hermetic Connectors                               |                  |   |
| Carbon Steel Shell, Tin Plated Shell and Contacts |                  | <b>SJT( Y)</b>                          |
| Stainless Steel Shell, Gold Plated Contacts       | Consult Amphenol |   |

38999
SJT

26482
Matrix 2

83723
Matrix Pyle

5015
Crimp Rear Release Matrix

26500
Pyle

Printed
Circuit Board

EMI Filter
Transient

Fiber Optics

High Speed
Contacts

Options
Others



| Shell Size | Crimp | Hermetics* Class Y | Service Rating | Total Contacts | Contact Size |     |     |    |       |    |           |            |          |               |
|------------|-------|--------------------|----------------|----------------|--------------|-----|-----|----|-------|----|-----------|------------|----------|---------------|
|            |       |                    |                |                | 22D          | 22M | 22  | 20 | 16    | 12 | 12 (Coax) | 10 (Power) | 8 (Coax) | 8††† (Twinax) |
| 8-6        | X     |                    | M              | 6              |              | 6   |     |    |       |    |           |            |          |               |
| 8-35       | X     |                    | M              | 6              | 6            |     |     |    |       |    |           |            |          |               |
| 8-44       | X     |                    | M              | 4              |              |     | 4   |    |       |    |           |            |          |               |
| 8-98       | X     |                    | I              | 3              |              |     |     | 3  |       |    |           |            |          |               |
| 10-2       | X     |                    | I              | 2              |              |     |     |    |       | 2  |           |            |          |               |
| 10-4       | ◆     |                    | I              | 4              |              |     |     | 4  |       |    |           |            |          |               |
| 10-5       | X     |                    | I              | 5              |              |     |     | 5  |       |    |           |            |          |               |
| 10-13      | X     |                    | M              | 13             |              | 13  |     |    |       |    |           |            |          |               |
| 10-35      | X     |                    | M              | 13             | 13           |     |     |    |       |    |           |            |          |               |
| 10-98      | X     |                    | I              | 6              |              |     |     | 6  |       |    |           |            |          |               |
| 12-4       | X     |                    | I              | 4              |              |     |     |    |       | 4  |           |            |          |               |
| 12-8       | X     |                    | I              | 8              |              |     |     | 8  |       |    |           |            |          |               |
| 12-22      | X     |                    | M              | 22             |              | 22  |     |    |       |    |           |            |          |               |
| 12-35      | X     |                    | M              | 22             | 22           |     |     |    |       |    |           |            |          |               |
| 12-98      | X     | X                  | I              | 10             |              |     |     | 10 |       |    |           |            |          |               |
| 14-5       | X     |                    | II             | 5              |              |     |     |    |       | 5  |           |            |          |               |
| 14-15      | X     |                    | I              | 15             |              |     |     |    |       | 1  |           |            |          |               |
| 14-18      | X     |                    | I              | 18             |              |     |     |    |       | 18 |           |            |          |               |
| 14-19      | X     | X                  | I              | 19             |              |     |     |    |       | 19 |           |            |          |               |
| 14-35      | X     | X                  | M              | 37             | 37           |     |     |    |       |    |           |            |          |               |
| 14-37      | X     | X                  | M              | 37             |              | 37  |     |    |       |    |           |            |          |               |
| 14-97      | X     |                    | I              | 12             |              |     |     | 8  |       | 4  |           |            |          |               |
| 16-2       | ◆     |                    | M              | 39             | 38           |     |     |    |       |    |           |            |          | 1**           |
| 16-6       | X     |                    | I              | 6              |              |     |     |    |       |    | 6         |            |          |               |
| 16-8       | X     |                    | II             | 8              |              |     |     |    |       | 8  |           |            |          |               |
| 16-13      | ◆     |                    | I              | 13             |              |     |     |    |       | 13 |           |            |          |               |
| 16-26      | X     |                    | I              | 26             |              |     |     |    | 26    |    |           |            |          |               |
| 16-35      | X     |                    | M              | 55             | 55           |     |     |    |       |    |           |            |          |               |
| 16-42      | X     |                    | M              | 42             |              |     | 42  |    |       |    |           |            |          |               |
| 16-55      | X     |                    | M              | 55             |              | 55  |     |    |       |    |           |            |          |               |
| 16-99      | X     | X                  | I              | 23             |              |     |     |    | 21    | 2  |           |            |          |               |
| 18-11      | X     |                    | II             | 11             |              |     |     |    |       | 11 |           |            |          |               |
| 18-32      | X     |                    | I              | 32             |              |     |     |    | 32    |    |           |            |          |               |
| 18-35      | X     | X                  | M              | 66             | 66           |     |     |    |       |    |           |            |          |               |
| 18-66      | X     | X                  | M              | 66             |              | 66  |     |    |       |    |           |            |          |               |
| 20-1       | X     | X                  | M              | 79             |              | 79  |     |    |       |    |           |            |          |               |
| 20-2       | X     |                    | M              | 65             |              |     | 65  |    |       |    |           |            |          |               |
| 20-11      | X     |                    | I              | 11             |              |     |     |    |       |    | 11        |            |          |               |
| 20-16      | X     |                    | II             | 16             |              |     |     |    |       | 16 |           |            |          |               |
| 20-35      | X     | X                  | M              | 79             | 79           |     |     |    |       |    |           |            |          |               |
| 20-39      | X     |                    | I              | 39             |              |     |     |    | 37    | 2  |           |            |          |               |
| 20-41      | X     |                    | I              | 41             |              |     |     |    | 41    |    |           |            |          |               |
| 20-75      | ◆     |                    | M              | 4              |              |     |     |    |       |    |           |            |          | 4††           |
| 20-79      | ◆     |                    | II             | 19             | 17           |     |     |    |       |    |           |            |          | 2†            |
| 22-1       | X     | X                  | M              | 100            |              | 100 |     |    |       |    |           |            |          |               |
| 22-2       | X     |                    | M              | 85             |              |     | 85  |    |       |    |           |            |          |               |
| 22-21      | X     |                    | II             | 21             |              |     |     |    |       | 21 |           |            |          |               |
| 22-35      | X     | X                  | M              | 100            | 100          |     |     |    |       |    |           |            |          |               |
| 22-53      | X     |                    | I              | 53             |              |     |     |    | 53    |    |           |            |          |               |
| 24-1       | X     |                    | M              | 128            |              | 128 |     |    |       |    |           |            |          |               |
| 24-2       | X     |                    | M              | 100            |              |     | 100 |    |       |    |           |            |          |               |
| 24-4       | X     |                    | I              | 56             |              |     |     | 48 |       | 8  |           |            |          |               |
| 24-7       | X     |                    | M              | 99             | 97           |     |     |    |       |    |           |            |          | 2**           |
| 24-11      | ◆     |                    | N              | 11             |              |     |     | 2  |       |    |           | 9          |          |               |
| 24-19      | X     |                    | I              | 19             |              |     |     |    |       |    | 19        |            |          |               |
| 24-20      | ◆     |                    | N              | 30             |              |     |     | 10 | 13*** |    | 4         |            |          | 3             |
| 24-24      | X     |                    | I              | 24             |              |     |     |    | 12    | 12 |           |            |          |               |
| 24-29      | X     |                    | I              | 29             |              |     |     |    | 29    |    |           |            |          |               |
| 24-35      | X     |                    | M              | 128            | 128          |     |     |    |       |    |           |            |          |               |
| 24-37      | X     |                    | I              | 37             |              |     |     |    |       | 37 |           |            |          |               |
| 24-43      | ◆     |                    | I              | 43             |              |     |     | 23 |       | 20 |           |            |          |               |
| 24-46      | ◆     |                    | I              | 46             |              |     |     | 40 |       | 4  |           |            |          | 2††           |
| 24-61      | X     |                    | I              | 61             |              |     |     | 61 |       |    |           |            |          |               |

◆ Not tooled for 02-RE

\* Pin inserts only (contact Amphenol for socket availability).

\*\* twinax contacts for MIL-C-17/176-00002 cable.

\*\*\* Two size 16 contacts dedicated to fiber optics. Consult Amphenol or Fiber Optic Section for more information.

† Must be ordered separately

†† Coax Contacts for RG180 or RG195 cable.

††† Size 8 Coax and Twinax are interchangeable.  
For availability of size 12 twinax contacts, consult Amphenol, Sidney, NY

# SJT00RT – Crimp Wall Mounting Receptacle

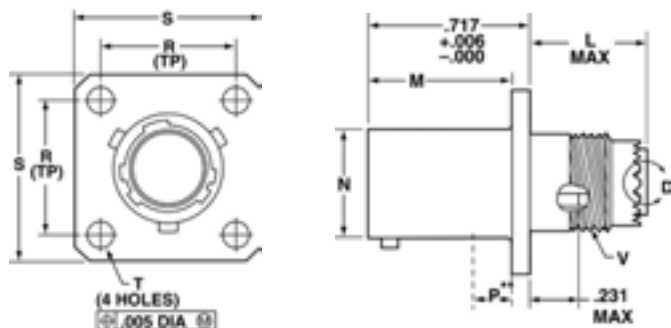

**PART #** \*To complete, see how to order pages 83-84.

| Connector Type | Shell Style | Service Class | Shell Size & Insert Arrg | Contact Type | Alternate Positions | Special Variations |
|----------------|-------------|---------------|--------------------------|--------------|---------------------|--------------------|
| SJT            | 00          | RT            | X-X                      | X            | X                   | (XXX)              |

Note: Standard wall mount may be back panel mounted where panel thickness does not exceed these dimensions. For thicker panel applications, SJTP00RT should be used.

| Shell Size | L Max | M +.000 -0.005 | R (TP) | S ±.016 | T ±.005 | V Thread Modified      |                     |       | N +.001 -0.005 | P** Max |
|------------|-------|----------------|--------|---------|---------|------------------------|---------------------|-------|----------------|---------|
|            |       |                |        |         |         | Class 2A UNEF (Plated) | Modified Major Dia. |       |                |         |
| 8          | .500  | .632           | .594   | .812    | .120    | .4375-28               | .421 - .417         | .473  | .117           |         |
| 10         | .500  | .632           | .719   | .938    | .120    | .5625-24               | .542 - .538         | .590  | .117           |         |
| 12         | .500  | .632           | .812   | 1.031   | .120    | .6875-24               | .667 - .663         | .750  | .117           |         |
| 14         | .500  | .632           | .906   | 1.125   | .120    | .8125-20               | .791 - .787         | .875  | .117           |         |
| 16         | .500  | .632           | .969   | 1.219   | .120    | .9375-20               | .916 - .912         | 1.000 | .117           |         |
| 18         | .500  | .632           | 1.062  | 1.312   | .120    | 1.0625-18              | 1.034 - 1.030       | 1.125 | .117           |         |
| 20         | .500  | .602           | 1.156  | 1.438   | .120    | 1.1875-18              | 1.158 - 1.154       | 1.250 | .087           |         |
| 22         | .500  | .602           | 1.250  | 1.562   | .120    | 1.3125-18              | 1.283 - 1.279       | 1.375 | .087           |         |
| 24         | .550  | .602           | 1.375  | 1.688   | .147    | 1.4375-18              | 1.408 - 1.404       | 1.500 | .055           |         |

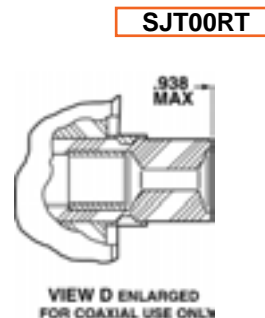

# SJTP00RT – Crimp Wall Mounting Receptacle (Back Panel Mounting)

**PART #** To complete, see how to order pages 83-84.

| Connector Type | Shell Style | Service Class | Shell Size & Insert Arrg | Contact Type | Alternate Positions | Special Variations |
|----------------|-------------|---------------|--------------------------|--------------|---------------------|--------------------|
| SJTP           | 00          | RT            | X-X                      | X            | X                   | (XXX)              |

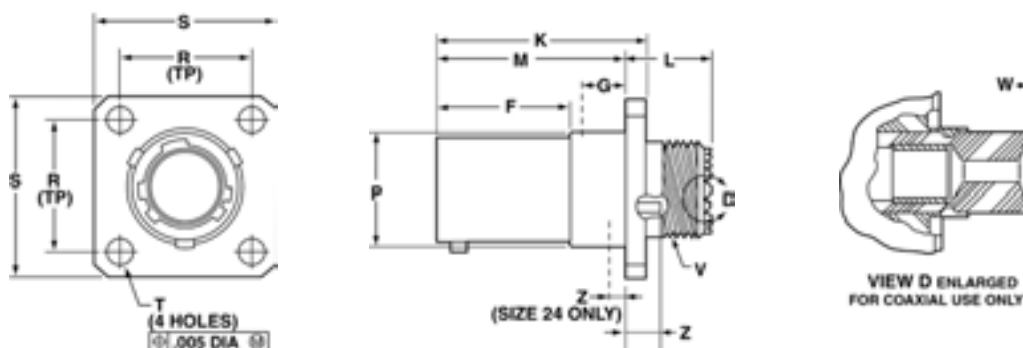

| Shell Size | F +.000 -0.005 | K +.006 -0.000 | L Max. | M +.000 -0.005 | R (TP) | S +.011 -0.010 | T ±.005 | Z ±.031 | V Thread Class 2A (Plated) UNEF | P Dia. +.001 -0.005 | W Max. | G Max. |
|------------|----------------|----------------|--------|----------------|--------|----------------|---------|---------|---------------------------------|---------------------|--------|--------|
| 8          | .609           | .945           | .539   | .860           | .594   | .812           | .120    | .062    | .4375-28                        | .516                | .812   | .345   |
| 10         | .609           | .945           | .539   | .860           | .719   | .938           | .120    | .062    | .5625-24                        | .633                | .812   | .345   |
| 12         | .609           | .945           | .539   | .860           | .812   | 1.031          | .120    | .062    | .6875-24                        | .802                | .812   | .345   |
| 14         | .609           | .945           | .539   | .860           | .906   | 1.125          | .120    | .062    | .8125-20                        | .927                | .812   | .345   |
| 16         | .609           | .945           | .539   | .860           | .969   | 1.219          | .120    | .062    | .9375-20                        | 1.052               | .812   | .345   |
| 18         | .609           | .945           | .539   | .860           | 1.062  | 1.312          | .120    | .062    | 1.0625-18                       | 1.177               | .812   | .345   |
| 20         | .609           | .945           | .539   | .860           | 1.156  | 1.438          | .120    | .062    | 1.1875-18                       | 1.302               | .812   | .345   |
| 22         | .609           | .945           | .539   | .860           | 1.250  | 1.562          | .120    | .062    | 1.3125-18                       | 1.427               | .812   | .345   |
| 24         | .750           | 1.085          | .493   | 1.000          | 1.375  | 1.688          | .147    | .078    | 1.4375-18                       | 1.552               | .781   | .452   |

All dimensions for reference only.

38999

SJT

26482 Matrix 2

83723 III Matrix Pyle

5015 Crimp Rear Release Matrix

26500 Pyle

Printed Circuit Board

EMI Filter Transient

Fiber Optics

High Speed Contacts

Options Others

**PART #** To complete, see how to order pages 83-84.

| Connector Type | Shell Style | Service Class | Shell Size & Insert Arrg | Contact Type | Alternate Positions | Special Variations |
|----------------|-------------|---------------|--------------------------|--------------|---------------------|--------------------|
| SJTP           | 02          | RE            | X-X                      | X            | X                   | (XXX)              |



**SJTP02RE**

| Shell Size | F<br>+.000<br>-.005 | K<br>+.006<br>-.000 | M<br>+.000<br>-.005 | R<br>(TP) | S<br>+.011<br>-.010 | T<br>±.005 | Z<br>±.031 | P<br>Dia.<br>+.001<br>-.005 | KK<br>Dia.<br>+.005<br>-.002 | G<br>Max. |
|------------|---------------------|---------------------|---------------------|-----------|---------------------|------------|------------|-----------------------------|------------------------------|-----------|
| 8          | .609                | .945                | .860                | .594      | .812                | .120       | .062       | .516                        | .417                         | .345      |
| 10         | .609                | .945                | .860                | .719      | .938                | .120       | .062       | .633                        | .538                         | .345      |
| 12         | .609                | .945                | .860                | .812      | 1.031               | .120       | .062       | .802                        | .663                         | .345      |
| 14         | .609                | .945                | .860                | .906      | 1.125               | .120       | .062       | .927                        | .787                         | .345      |
| 16         | .609                | .945                | .860                | .969      | 1.219               | .120       | .062       | 1.052                       | .912                         | .345      |
| 18         | .609                | .945                | .860                | 1.062     | 1.312               | .120       | .062       | 1.177                       | 1.030                        | .345      |
| 20         | .609                | .945                | .860                | 1.156     | 1.438               | .120       | .062       | 1.302                       | 1.154                        | .345      |
| 22         | .609                | .945                | .860                | 1.250     | 1.562               | .120       | .062       | 1.427                       | 1.279                        | .345      |
| 24         | .750                | 1.085               | 1.000               | 1.375     | 1.688               | .147       | .078       | 1.552                       | 1.404                        | .452      |

**PART #** To complete, see how to order pages 83-84.

| Connector Type | Shell Style | Service Class | Shell Size & Insert Arrg | Contact Type | Alternate Positions | Special Variations |
|----------------|-------------|---------------|--------------------------|--------------|---------------------|--------------------|
| SJT            | 07          | RT            | X-X                      | X            | X                   | (XXX)              |

## SJT07RT – Crimp Jam Nut Receptacle

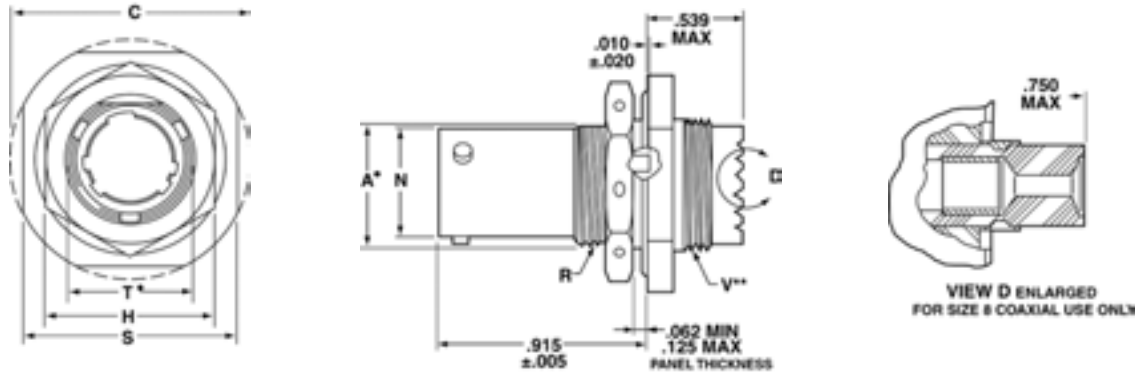

**SJT07RT**

- "D" shaped panel cut-out dimensions
- \*\* Oversize threads. Check accessory threads before ordering

| Shell Size | A*<br>+.000<br>-.010 | H<br>Hex<br>+.017<br>-.016 | S<br>±.016 | VThread<br>Class 2A<br>UNEF (Plated) | RThread<br>Class 2A<br>UNEF (Plated) | N<br>+.001<br>-.005 | C<br>Max. | T*<br>+.010<br>-.000 |
|------------|----------------------|----------------------------|------------|--------------------------------------|--------------------------------------|---------------------|-----------|----------------------|
| 8          | .542                 | .750                       | .938       | .5625-24                             | .5625-24                             | .473                | 1.078     | .572                 |
| 10         | .669                 | .875                       | 1.062      | .6875-24                             | .6875-24                             | .590                | 1.203     | .697                 |
| 12         | .830                 | 1.062                      | 1.250      | .8125-20                             | .8750-20                             | .750                | 1.391     | .884                 |
| 14         | .955                 | 1.188                      | 1.375      | .9375-20                             | 1.0000-20                            | .875                | 1.515     | 1.007                |
| 16         | 1.084                | 1.312                      | 1.500      | 1.0625-18                            | 1.1250-18                            | 1.000               | 1.641     | 1.134                |
| 18         | 1.208                | 1.438                      | 1.625      | 1.1875-18                            | 1.2500-18                            | 1.125               | 1.766     | 1.259                |
| 20         | 1.333                | 1.562                      | 1.812      | 1.3125-18                            | 1.3750-18                            | 1.250               | 1.953     | 1.384                |
| 22         | 1.459                | 1.688                      | 1.938      | 1.4375-18                            | 1.5000-18                            | 1.375               | 2.078     | 1.507                |
| 24         | 1.580                | 1.812                      | 2.062      | 1.4375-18                            | 1.6250-18                            | 1.500               | 2.203     | 1.634                |

All dimensions for reference only.

# SJT06RT/SJTG06RT – Crimp

## Straight Plug/Straight Plug (with Grounding Fingers)

**PART #** To complete, see how to order pages 83-84.

| Connector Type | Shell Style | Service Class | Shell Size & Insert Arrg | Contact Type | Alternate Positions | Special Variations |
|----------------|-------------|---------------|--------------------------|--------------|---------------------|--------------------|
| SJT            | 06          | RT            | X-X                      | X            | X                   | (XXX)              |
| SJTG           | 06          | RT            | X-X                      | X            | X                   | (XXX)              |

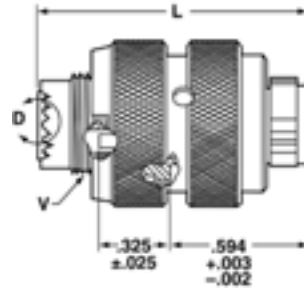

**SJT06RT**

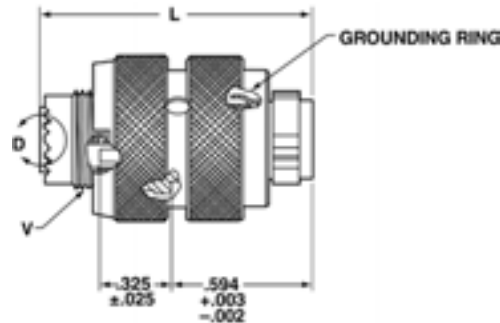
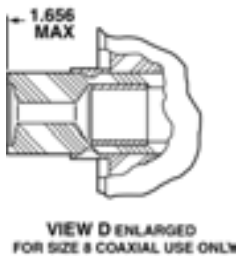

**SJTG06RT**



| Shell Size | L Max | Q Dia. Max. | VThread                |                     |
|------------|-------|-------------|------------------------|---------------------|
|            |       |             | Class 2A UNEF (Plated) | Modified Major Dia. |
| 8          | 1.219 | .734        | .4375-28               | .421 – .417         |
| 10         | 1.219 | .844        | .5625-24               | .542 – .538         |
| 12         | 1.219 | 1.016       | .6875-24               | .667 – .663         |
| 14         | 1.219 | 1.141       | .8125-20               | .791 – .787         |
| 16         | 1.219 | 1.265       | .9375-20               | .916 – .912         |
| 18         | 1.219 | 1.391       | 1.0625-18              | 1.034 – 1.030       |
| 20         | 1.219 | 1.500       | 1.1875-18              | 1.158 – 1.154       |
| 22         | 1.219 | 1.625       | 1.3125-18              | 1.283 – 1.279       |
| 24         | 1.258 | 1.750       | 1.4375-18              | 1.408 – 1.404       |

All dimensions for reference only.

- III 38999
- II
- I
- SJT
- Matrix 2 26482
- Matrix Pyle 83723 III
- Crimp Rear Release Matrix 5015
- 26500 Pyle
- Printed Circuit Board
- EMI Filter Transient
- Fiber Optics
- High Speed Contacts
- Options Others

38999  
SJT

26482  
Matrix 2

83723 III  
Matrix Pyle

5015  
Crimp Rear  
Release Matrix

26500 Pyle

Printed  
Circuit Board

EMI Filter  
Transient

Fiber Optics

High Speed  
Contacts

Options  
Others

**PART #** To complete, see how to order pages 83-84.

| Connector Type | Shell Style | Service Class | Shell Size & Insert Arrg | Contact Type | Alternate Positions | Special Variations |
|----------------|-------------|---------------|--------------------------|--------------|---------------------|--------------------|
| SJT            | I           | Y             | X-X                      | X            | X                   | (XXX)              |

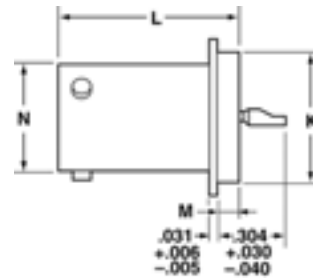
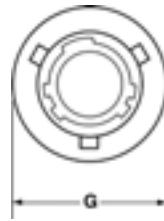

**SJTIY**

| Shell Size | L<br>+.011<br>-.000 | M<br>+.006<br>-.005 | G Dia.<br>+.011<br>-.010 | K Dia.<br>+.001<br>-.005 | N<br>+.001<br>-.005 |
|------------|---------------------|---------------------|--------------------------|--------------------------|---------------------|
| 8          | .789                | .125                | .687                     | .562                     | .473                |
| 10         | .789                | .125                | .797                     | .672                     | .590                |
| 12         | .789                | .125                | .906                     | .781                     | .750                |
| 14         | .789                | .125                | 1.031                    | .906                     | .875                |
| 16         | .789                | .125                | 1.156                    | 1.031                    | 1.000               |
| 18         | .789                | .125                | 1.281                    | 1.156                    | 1.125               |
| 20         | .789                | .125                | 1.375                    | 1.250                    | 1.250               |
| 22         | .821                | .156                | 1.500                    | 1.375                    | 1.375               |
| 24         | .821                | .156                | 1.625                    | 1.500                    | 1.500               |

**PART #** To complete, see how to order pages 83-84.

| Connector Type | Shell Style | Service Class | Shell Size & Insert Arrg | Contact Type | Alternate Positions | Special Variations |
|----------------|-------------|---------------|--------------------------|--------------|---------------------|--------------------|
| SJT            | 07          | Y             | X-X                      | X            | X                   | (XXX)              |

**SJT07Y – Hermetic  
Jam Nut Receptacle**

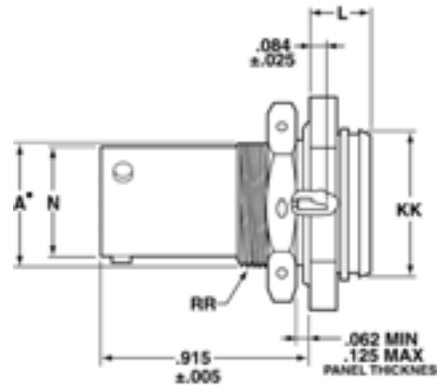
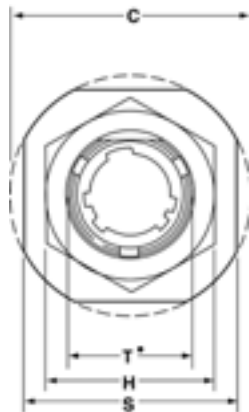

**SJT07Y**

• "D" shaped panel cut-out dimensions

| Shell Size | N<br>+.001<br>-.005 | C<br>Max. | A*<br>+.000<br>-.010 | L<br>Max. | H Hex<br>+.017<br>-.016 | S<br>±.016 | KK<br>+.011<br>-.000 | RR<br>Thread<br>Class 2A<br>UNEF (Plated) | T*<br>+.010<br>-.000 |
|------------|---------------------|-----------|----------------------|-----------|-------------------------|------------|----------------------|---|----------------------|
| 8          | .473                | 1.078     | .542                 | .297      | .750                    | .938       | .642                 | .5625-24                                  | .572                 |
| 10         | .590                | 1.203     | .669                 | .297      | .875                    | 1.062      | .766                 | .6875-24                                  | .697                 |
| 12         | .750                | 1.391     | .830                 | .297      | 1.062                   | 1.250      | .892                 | .8750-20                                  | .884                 |
| 14         | .875                | 1.515     | .955                 | .297      | 1.188                   | 1.375      | 1.018                | 1.0000-20                                 | 1.007                |
| 16         | 1.000               | 1.641     | 1.084                | .297      | 1.312                   | 1.500      | 1.142                | 1.1250-18                                 | 1.134                |
| 18         | 1.125               | 1.766     | 1.208                | .328      | 1.438                   | 1.625      | 1.268                | 1.2500-18                                 | 1.259                |
| 20         | 1.250               | 1.953     | 1.333                | .328      | 1.562                   | 1.812      | 1.392                | 1.3750-18                                 | 1.384                |
| 22         | 1.375               | 2.078     | 1.459                | .328      | 1.688                   | 1.938      | 1.518                | 1.5000-18                                 | 1.507                |
| 24         | 1.500               | 2.203     | 1.580                | .328      | 1.812                   | 2.062      | 1.642                | 1.6250-18                                 | 1.634                |

All dimensions for reference only.



Series III TV

Series II JT

Series I LJT

SJT

Amphenol Aerospace is the leader in Interconnect solutions and provides companies with a product portfolio of connectors, accessories, cable assemblies and system integration for most applications across various industries. With connectors conforming to Military, Aerospace and Industrial standards in US, Europe and Asia, Amphenol assumes the leadership in meeting the interconnect needs of these market segments.



### MIL-DTL-38999 Series III TV Tri-Start

- Backshells Accessories
- Dummy Contacts
- Wire Combs
- Receptacle Protection Cap
- Plug Protection Cap
- Dummy Receptacle
- Cable Clamps
- Contacts-Printed Circuit Board Wire Wrap
- Header Assembly

#### Application Tools

- Crimp Tools
- Insertion Tools
- Removal Tools

### MIL-DTL-38999 Series II JT

- Receptacle Protection Cap
- Plug Protection Cap
- Strain Relief (Solder/Crimp Type)
- Contacts-Printed Circuit Board Wire Wrap
- Header Assembly

#### Application Tools

- Crimp Tools
- Insertion Tools
- Removal Tools

### SJT

- Receptacle Protection Cap
- Plug Protection Cap
- Dummy Receptacle
- Cable Clamps

#### Application Tools

- Crimp Tools
- Insertion Tools
- Removal Tools

### MIL-DTL-38999 Series I LJT

- Receptacle Protection Cap
- Plug Protection Cap
- Dummy Receptacle
- Cable Clamps
- Contacts-Printed Circuit Board Wire Wrap
- Header Assembly

#### Application Tools

- Crimp Tools
- Insertion Tools
- Removal Tools



III  
II  
I  
SJT  
**38999**

26482  
Matrix 2

83723 III  
Matrix Pyle

5015  
Crimp Rear Release Matrix

26500 Pyle

Printed  
Circuit Board

EMI Filter  
Transient

Fiber Optics

High Speed  
Contacts

Options  
Others

**Series III TV**

Amphenol offers a full range of accessories that are designed to enhance the performance of Amphenol Breakaway connectors.

**Low Profile Backshells in shell size 25 with the following features:**

- Olive drab cadmium finish
- 90 degree termination
- Low profile design with three heights ranging from 1.010 to 1.660
- Rear access covers to help ease harness assembly and repairability
- Amphenol part numbers: 10-640000-XXX



Backshells are offered for use with Breakaway Fail Safe Connectors in three heights.



**Dummy Contacts**

- Available in size 12 and size 8
- Provide a cost effective alternative for sealing unused contact cavities
- Size 8 part number: T3-4008-59P
- Size 12 part number: T3-4012-59P

**Wire Combs**

- Available for the 25-20 insert pattern to help to stabilize and prevent contact side loading
- Amphenol part number: 21-33626-XXX

For information on how to order these accessory products for Breakaway Fail Safe connectors consult Amphenol Aerospace.

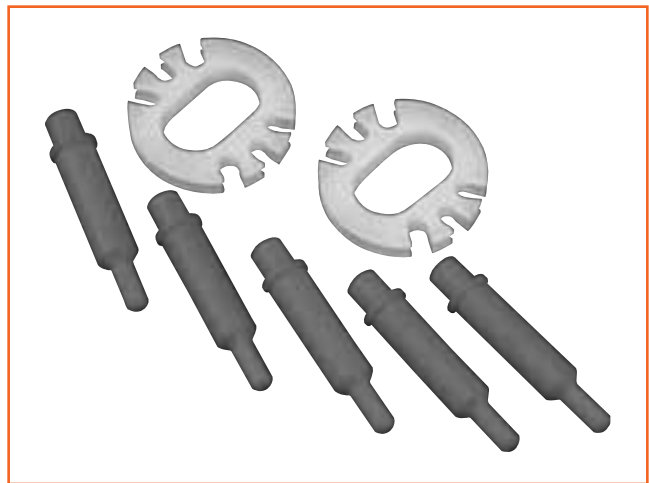

Accessory products for Breakaway Connectors: Dummy Contacts and Wire Combs

- 38999 III
- SJT I II
- 26482 Matrix 2
- 83723 III Pyle Matrix
- 5015 Crimp Rear Release Matrix
- 26500 Pyle
- Printed Circuit Board
- EMI Filter Transient
- Fiber Optics
- High Speed Contacts
- Options Others

# MIL-DTL-38999, Series III TV Receptacle Protection Cap

Series III TV

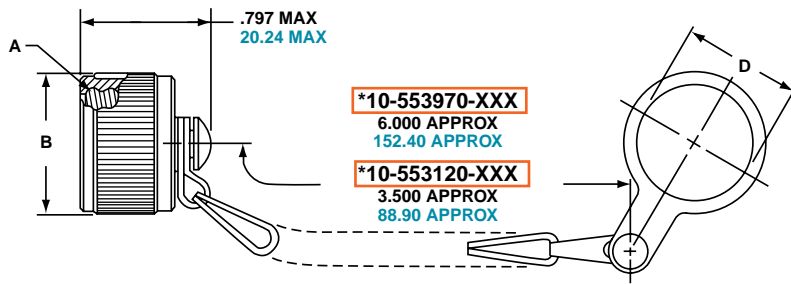
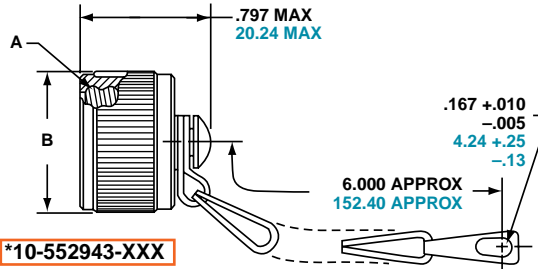
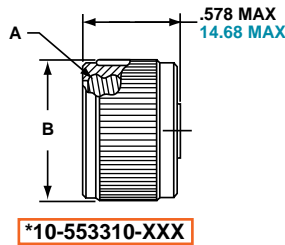

\* To complete order number, add shell size and suffix number.  
For example, shell size 11 with olive drab cadmium nickel base, **10-552943-119**

Inches

| Shell Size | A Thread Class 2B<br>0.1P-0.3L-TS | B Dia. Max. | D Dia.<br>+.010 - .000 |
|------------|-----------------------------------|-------------|------------------------|
| 9          | .6250                             | .875        | .703                   |
| 11         | .7500                             | 1.000       | .844                   |
| 13         | .8750                             | 1.125       | 1.016                  |
| 15         | 1.0000                            | 1.250       | 1.141                  |
| 17         | 1.1875                            | 1.438       | 1.266                  |
| 19         | 1.2500                            | 1.500       | 1.391                  |
| 21         | 1.3750                            | 1.625       | 1.516                  |
| 23         | 1.5000                            | 1.750       | 1.641                  |
| 25         | 1.6250                            | 1.875       | 1.766                  |

Millimeters

| Finish                           | 10-No Suffix |
|----------------------------------|--------------|
| Olive Drab, Cadmium, Nickel base | -XX9         |
| Electroless Nickel               | -XXG         |

| Shell Size | MS Shell Size Code | B Dia. Max. | D Dia. +.25<br>-.00 |
|------------|--------------------|-------------|---------------------|
| 9          | A                  | 22.23       | 17.86               |
| 11         | B                  | 25.40       | 21.44               |
| 13         | C                  | 28.58       | 25.81               |
| 15         | D                  | 31.75       | 28.98               |
| 17         | E                  | 36.53       | 32.16               |
| 19         | F                  | 38.10       | 35.33               |
| 21         | G                  | 41.28       | 38.51               |
| 23         | H                  | 44.45       | 41.68               |
| 25         | J                  | 47.63       | 44.86               |

Consult Amphenol Aerospace for availability of stainless steel protection caps.

All dimensions for reference only.  
For MS protection caps, see page 95.

- III 38999
- II
- I
- SJT
- 26482 Matrix 2
- 83723 III Matrix Pyle
- 5015 Crimp Rear Release Matrix
- 26500 Pyle
- Printed Circuit Board
- EMI Filter Transient
- Fiber Optics
- High Speed Contacts
- Options Others

### Series III TV

- 38999 III
- SJT I II
- 26482 Matrix 2
- 83723 III Pyle Matrix
- 5015 Crimp Rear Release Matrix
- 26500 Pyle
- Printed Circuit Board
- EMI Filter Transient
- Fiber Optics
- High Speed Contacts
- Options Others

**\*10-552944-XXX**

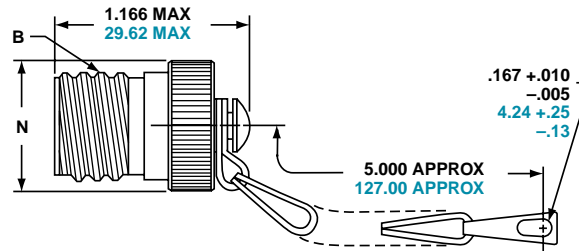

**\*10-553998-XXX**

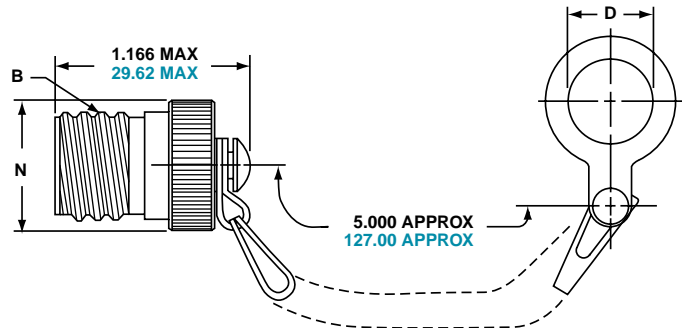

\* To complete order number, add shell size and suffix number.  
For example, shell size 11 with olive drab cadmium nickel base, **10-552944-119**

Inches

| Shell Size | A Thread Class 2B<br>0.1P-0.3L-TS | D Dia. +.010<br>-.000 | N Dia.<br>Max. |
|------------|-----------------------------------|-----------------------|----------------|
| 9          | .6250                             | .516                  | .895           |
| 11         | .7500                             | .641                  | 1.000          |
| 13         | .8750                             | .766                  | 1.171          |
| 15         | 1.0000                            | .891                  | 1.299          |
| 17         | 1.1875                            | 1.016                 | 1.436          |
| 19         | 1.2500                            | 1.141                 | 1.543          |
| 21         | 1.3750                            | 1.266                 | 1.670          |
| 23         | 1.5000                            | 1.343                 | 1.787          |
| 25         | 1.6250                            | 1.516                 | 1.914          |

Millimeters

| Finish                           | 10-No Suffix |
|----------------------------------|--------------|
| Olive Drab, Cadmium, Nickel base | -XX9         |
| Electroless Nickel               | -XXG         |

| Shell Size | MS Shell Size Code | D Dia.<br>+.25 -.00 | N Dia.<br>Max. |
|------------|--------------------|---------------------|----------------|
| 9          | A                  | 13.11               | 22.73          |
| 11         | B                  | 16.28               | 25.40          |
| 13         | C                  | 19.46               | 29.74          |
| 15         | D                  | 22.63               | 32.99          |
| 17         | E                  | 25.81               | 36.47          |
| 19         | F                  | 28.98               | 39.19          |
| 21         | G                  | 32.16               | 42.42          |
| 23         | H                  | 34.11               | 45.39          |
| 25         | J                  | 38.51               | 48.62          |

Consult Amphenol Aerospace for availability of stainless steel protection caps.

All dimensions for reference only.  
For MS protection caps, see page 95.

# MIL-DTL-38999, Series III TV Dummy Receptacle



Series III TV

Part number reference.  
See note below to complete.  
  
\* 10-553974-XXX

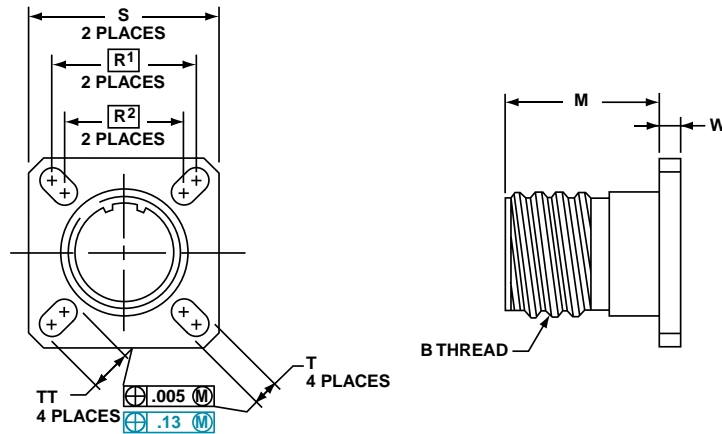

\* To complete order number, add shell size and suffix number.  
For example, shell size 11 with olive drab cadmium nickel base, 10-553974-119

Inches

| Shell Size | MS Shell Size Coded | B Thread 0.1P-0.3L-TS (Plated) | M +.020 - .000 | R <sup>1</sup> | R <sup>2</sup> | S ±.010 | T ±.008 - .006 | W ±.010 | TT ±.008 - .006 |
|------------|---------------------|--------------------------------|----------------|----------------|----------------|---------|----------------|---------|-----------------|
| 9          | A                   | .6250                          | .822           | .719           | .594           | .938    | .128           | .098    | .216            |
| 11         | B                   | .7500                          | .822           | .812           | .719           | 1.031   | .128           | .098    | .194            |
| 13         | C                   | .8750                          | .822           | .906           | .812           | 1.125   | .128           | .098    | .194            |
| 15         | D                   | 1.0000                         | .822           | .969           | .906           | 1.219   | .128           | .098    | .173            |
| 17         | E                   | 1.1875                         | .822           | 1.062          | .969           | 1.312   | .128           | .098    | .194            |
| 19         | F                   | 1.2500                         | .822           | 1.156          | 1.062          | 1.438   | .128           | .098    | .194            |
| 21         | G                   | 1.3750                         | .791           | 1.250          | 1.156          | 1.562   | .128           | .125    | .194            |
| 23         | H                   | 1.5000                         | .791           | 1.375          | 1.250          | 1.688   | .154           | .125    | .242            |
| 25         | J                   | 1.6250                         | .791           | 1.500          | 1.375          | 1.812   | .154           | .125    | .242            |

| Finish                           | 10-No Suffix |
|----------------------------------|--------------|
| Olive Drab, Cadmium, Nickel base | -XX9         |
| Electroless Nickel               | -XXG         |

Millimeters

| Shell Size | MS Shell Size Coded | M +.51 - .00 | R <sup>1</sup> | R <sup>2</sup> | S ±.25 | T +.20 - .15 | W ±.25 | TT +.20 - .15 |
|------------|---------------------|--------------|----------------|----------------|--------|--------------|--------|---------------|
| 9          | A                   | 20.88        | 18.26          | 15.09          | 23.83  | 3.25         | 2.49   | 5.49          |
| 11         | B                   | 20.88        | 20.62          | 18.26          | 26.19  | 3.25         | 2.49   | 4.93          |
| 13         | C                   | 20.88        | 23.01          | 20.62          | 28.58  | 3.25         | 2.49   | 4.93          |
| 15         | D                   | 20.88        | 24.61          | 23.01          | 30.96  | 3.25         | 2.49   | 4.93          |
| 17         | E                   | 20.88        | 26.97          | 24.61          | 33.32  | 3.25         | 2.49   | 4.93          |
| 19         | F                   | 20.88        | 29.36          | 26.97          | 36.53  | 3.25         | 2.49   | 4.93          |
| 21         | G                   | 20.09        | 31.75          | 29.36          | 39.67  | 3.25         | 3.18   | 4.93          |
| 23         | H                   | 20.09        | 34.93          | 31.75          | 42.88  | 3.91         | 3.18   | 6.15          |
| 25         | J                   | 20.09        | 38.10          | 34.93          | 46.02  | 3.91         | 3.18   | 6.15          |

All dimensions for reference only

Designates true position dimensioning

- III 38999
- II
- I
- SJT
- 26482 Matrix 2
- 83723 III Matrix Pyle
- 5015 Crimp Rear Release Matrix
- 26500 Pyle
- Printed Circuit Board
- EMI Filter Transient
- Fiber Optics
- High Speed Contacts
- Options Others



### Series III TV

- 38999 III
- SJT I II
- 26482 Matrix 2
- 83723 III Pyle Matrix
- 5015 Crimp Rear Release Matrix
- 26500 Pyle
- Printed Circuit Board
- EMI Filter Transient
- Fiber Optics
- High Speed Contacts
- Options Others

**Straight Style**  
**\*10-552681-XXX** metal coupling

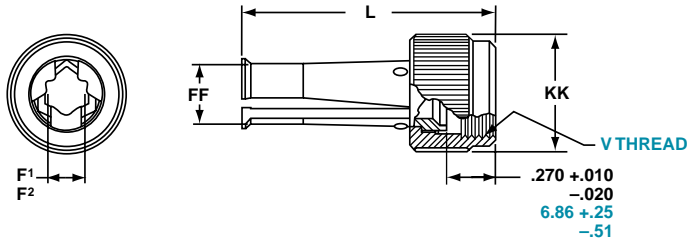

**90 Degree Elbow Style**  
**\*10-552682-XXX** metal coupling

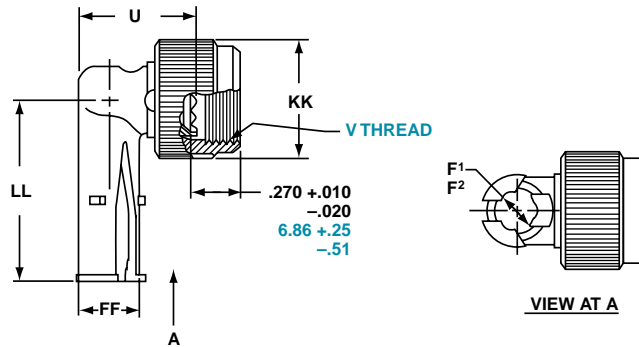

\* To complete order number, see suffix chart below. Examples:  
 Clamp with metal coupling nut for shell size 11 with olive drab cadmium nickel base, **10-552681-119.**

| Inches     |                    |                                |                                |        |        |              |              |         |
|------------|--------------------|--------------------------------|--------------------------------|--------|--------|--------------|--------------|---------|
| Shell Size | MS Shell Size Code | F <sup>1</sup> Min. Dia. Cable | F <sup>2</sup> Max. Dia. Cable | L Max. | U Max. | FF Dia. Max. | KK Dia. Max. | LL Max. |
| 9          | A                  | .094                           | .203                           | 1.431  | .656   | .347         | .629         | 1.015   |
| 11         | B                  | .141                           | .250                           | 1.431  | .688   | .394         | .756         | 1.062   |
| 13         | C                  | .172                           | .323                           | 1.431  | .750   | .467         | .883         | 1.125   |
| 15         | D                  | .203                           | .422                           | 1.431  | .859   | .566         | 1.011        | 1.328   |
| 17         | E                  | .234                           | .500                           | 1.431  | .937   | .644         | 1.138        | 1.392   |
| 19         | F                  | .265                           | .562                           | 1.431  | 1.000  | .706         | 1.265        | 1.453   |
| 21         | G                  | .297                           | .625                           | 1.492  | 1.062  | .769         | 1.393        | 1.609   |
| 23         | H                  | .328                           | .703                           | 1.492  | 1.141  | .847         | 1.488        | 1.656   |
| 25         | J                  | .359                           | .765                           | 1.492  | 1.203  | .909         | 1.616        | 1.719   |

| Finish                          | 10-No Suffix |
|---------------------------------|--------------|
| Olive Drab, Cadmium Nickel Base | -XX9         |
| Electroless Nickel              | -XXG         |

| Millimeters |                    |                                |                                |        |        |                 |              |              |         |  |
|-------------|--------------------|--------------------------------|--------------------------------|--------|--------|-----------------|--------------|--------------|---------|--|
| Shell Size  | MS Shell Size Code | F <sup>1</sup> Min. Dia. Cable | F <sup>2</sup> Max. Dia. Cable | L Max. | U Max. | V Thread Metric | FF Dia. Max. | KK Dia. Max. | LL Max. |  |
| 9           | A                  | 2.39                           | 5.16                           | 36.35  | 16.66  | M12X1-6H        | 8.81         | 15.98        | 25.78   |  |
| 11          | B                  | 3.58                           | 6.35                           | 36.35  | 17.48  | M15X1-6H        | 10.01        | 19.20        | 26.97   |  |
| 13          | C                  | 4.37                           | 8.20                           | 36.35  | 19.05  | M18X1-6H        | 11.86        | 22.43        | 28.58   |  |
| 15          | D                  | 5.16                           | 10.72                          | 36.35  | 21.82  | M22X1-6H        | 14.38        | 25.68        | 33.73   |  |
| 17          | E                  | 5.94                           | 12.70                          | 36.35  | 23.80  | M25X1-6H        | 16.36        | 28.91        | 35.36   |  |
| 19          | F                  | 6.73                           | 14.27                          | 36.35  | 25.40  | M28X1-6H        | 17.93        | 32.13        | 36.91   |  |
| 21          | G                  | 7.54                           | 15.88                          | 37.90  | 26.97  | M31X1-6H        | 19.53        | 35.38        | 40.87   |  |
| 23          | H                  | 8.83                           | 17.86                          | 37.90  | 28.98  | M34X1-6H        | 21.51        | 37.80        | 42.06   |  |
| 25          | J                  | 9.12                           | 19.43                          | 37.90  | 30.56  | M37X1-6H        | 23.09        | 41.05        | 43.66   |  |

All dimensions for reference only.

### STANDARD 500 CYCLE CONTACTS FOR TV AND CTV, P & S

| Contact Size | TV/CTV Pins     |             | TV/CTV Sockets |             |
|--------------|-----------------|-------------|----------------|-------------|
|              | Military No.    | Supersedes  | Military No.   | Supersedes  |
| 8 (Coax)*    | M39029/60-367   | MS27536     | M39029/59-366  | MS27535     |
| 8 (Power)    | Contact Factory | NA          | NA             | NA          |
| 8 (Twinax)** | M39029/90-529   | N/A         | M39029/91-530  | N/A         |
| 10 (Power)   | M39029/58-528   | N/A         | M39029/56-527  | N/A         |
| 12           | M39029/58-365   | MS27493-12  | M39029/56-353  | MS27490-12  |
| 16           | M39029/58-364   | MS27493-16  | M39029/56-352  | MS27490-16  |
| 20           | M39029/58-363   | MS27493-20  | M39029/56-351  | MS27490-20  |
| 22D          | M39029/58-360   | MS27493-22D | M39029/56-348  | MS27490-22D |
| 4            | N/A             | N/A         | N/A            | N/A         |
| 0            | N/A             | N/A         | N/A            | N/A         |

Above part numbers include standard 500 cycle finish designation - gold plating over suitable underplate in accordance with SAE AS39029. For other finish variations, consult Amphenol.

\*For use with RG180B/U and RG195A/U cable. For other size 8 coax or optional sizes 12 and 16 coax contacts available for use in MIL-DTL-38999 Series III connectors, see the High Speed Contact section of this catalog consult Amphenol, Sidney, NY

\*\* For use with M17/M176-00002 cable. For other contact options available for use in Tri-Start connectors, (wire wrap, thermocouple, fiber optic) consult Amphenol.

### 1500 CYCLE CONTACTS FOR CTV, CLASSES H & J

| Contact Size | CTV Pins       |                |            | CTV Sockets    |                |            |
|--------------|----------------|----------------|------------|----------------|----------------|------------|
|              | Commercial No. | Military No.   | Supersedes | Commercial No. | Military No.   | Supersedes |
| 12           | 10-597072-2X   | M39029/107-623 | -          | 10-597073-2X   | M39029/106-617 | -          |
| 16           | 10-597068-2X   | M39029/107-622 | -          | 10-597069-2X   | M39029/106-616 | -          |
| 20           | 10-597064-2X   | M39029/107-621 | -          | 10-597065-2X   | M39029/106-615 | -          |
| 22D          | 10-597058-3X   | M39029/107-620 | -          | 10-597061-2X   | M39029/106-614 | -          |

### PLASTIC PROTECTION CAPS

| Shell Size | Plug        | Receptacle  |
|------------|-------------|-------------|
| 9          | 10-70506-14 | 10-70500-10 |
| 11         | 10-70506-16 | 10-70500-12 |
| 13         | 10-70500-18 | 10-70500-14 |
| 15         | 10-70500-20 | 10-70500-16 |
| 17         | 10-70500-22 | 10-70500-19 |
| 19         | 10-70500-24 | 10-70500-20 |
| 21         | 10-70524-1  | 10-70500-22 |
| 23         | 10-70506-28 | 10-70500-24 |
| 25         | 10-70500-28 | 10-70524-1  |

### MS METAL PROTECTION CAPS

| Shell Size | MS Shell Size Code | MS Plug Protection Cap | MS Receptacle Protection Cap |
|------------|--------------------|------------------------|------------------------------|
| 9          | A                  | D38999/32W9X*          | D38999/33W9X*                |
| 11         | B                  | D38999/32W11X*         | D38999/33W11X*               |
| 13         | C                  | D38999/32W13X*         | D38999/33W13X*               |
| 15         | D                  | D38999/32W15X*         | D38999/33W15X*               |
| 17         | E                  | D38999/32W17X*         | D38999/33W17X*               |
| 19         | F                  | D38999/32W19X*         | D38999/33W19X*               |
| 21         | G                  | D38999/32W21X*         | D38999/33W21X*               |
| 23         | H                  | D38999/32W23X*         | D38999/33W23X*               |
| 25         | J                  | D38999/32W25X*         | D38999/33W25X*               |

\* To complete order number, replace X with applicable letter as follows:  
 R - designates eyelet type  
 N - designates washer type

MS metal protection caps are supplied with service class W which designates corrosion resistant olive drab cadmium plate aluminum. Consult Amphenol, Sidney, NY for more detailed information on ordering MS Metal protection caps.

### SEALING PLUGS

| Contact Size | Commercial No. | Military No. |
|--------------|----------------|--------------|
| 8 (Coax)     | 10-482099-8    | N/A          |
| 8 (Twinax)   | T3-4008-59P    | N/A          |
| 8 (Power)    | 10-405996-83   | MS27488-8-3  |
| 10 (Power)   | T3-4010-59P    | M85049/81-10 |
| 12           | 10-405996-122  | MS27488-12-2 |
| 16           | 10-405996-162  | MS27488-16-2 |
| 20           | 10-405996-202  | MS27488-20-2 |
| 22D          | 10-405996-222  | MS27488-22-2 |
| 4            | 10-405996-43   | MS27488-4-3  |
| 0            | 10-405996-03   | MS27488-0-3  |

III  
II  
I  
SJT  
38999

Matrix 2  
26482

Matrix  
Pyle  
83723 III

Crimp Rear  
Release Matrix  
5015

Pyle  
26500

Printed  
Circuit Board

EMI Filter  
Transient

Fiber Optics

High Speed  
Contacts

Options  
Others

### Series II JT

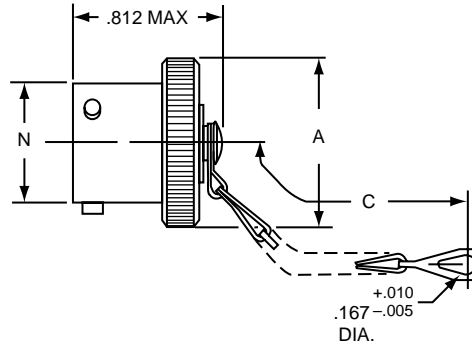
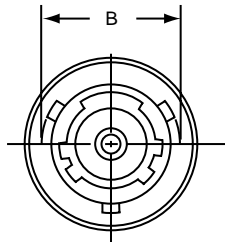

\* **10-547138-XXX (MS27510XXXC)**

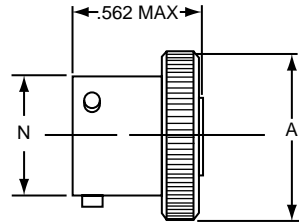

\* **10-241853-XXX (MS27510XXXA)**

For MS stamping identification, accessories must be ordered by MS part number.

If ordered by 10- part number, they will be stamped with said number.

\* To complete order number, add shell size and suffix number.

For example, shell size 10 with cadmium plate, nickel base would be **10-241853-107, MS27510A10C or MS27510A10A).**

| Shell Size | A Dia. Max. | A' Dia. Max. | B<br>+.000<br>-.016 | C<br>Approx. | N Dia.<br>+.001<br>-.005 |
|------------|-------------|--------------|---------------------|--------------|--------------------------|
| 8          | .719        | .703         | .563                | 3.000        | .473                     |
| 10         | .844        | .828         | .680                | 3.000        | .590                     |
| 12         | 1.000       | .984         | .859                | 3.500        | .750                     |
| 14         | 1.125       | 1.109        | .984                | 3.500        | .875                     |
| 16         | 1.250       | 1.234        | 1.108               | 3.500        | 1.000                    |
| 18         | 1.375       | 1.359        | 1.233               | 3.500        | 1.125                    |
| 20         | 1.500       | 1.484        | 1.358               | 4.000        | 1.250                    |
| 22         | 1.625       | 1.609        | 1.483               | 4.000        | 1.375                    |
| 24         | 1.750       | 1.734        | 1.610               | 4.000        | 1.500                    |

| Finish                           | 10-Number Suffix | MS Number Suffix with chain | MS Number Suffix without chain |
|----------------------------------|------------------|-----------------------------|--------------------------------|
| Chromate treat                   | -XX0             |                             |                                |
| Anodic coating                   | -XX5             | CXXC                        | CXXA                           |
| Cadmium Plate Nickel base        | -XX7             | AXXC                        | AXXA                           |
| Olive Drab, Cadmium, Nickel base | -XX9             | BXXC                        | BXXA                           |
| Electroless Nickel               | -XXG             | FXXC                        | FXXA                           |

All dimensions for reference only.

- 38999 SJT I II III
- 26482 Matrix 2
- 83723 III Matrix Pyle
- 5015 Crimp Rear Release Matrix
- 26500 Pyle
- Printed Circuit Board
- EMI Filter Transient
- Fiber Optics
- High Speed Contacts
- Options Others

# MIL-DTL-38999, Series II JT

## Receptacle Protection Cap

Series II JT

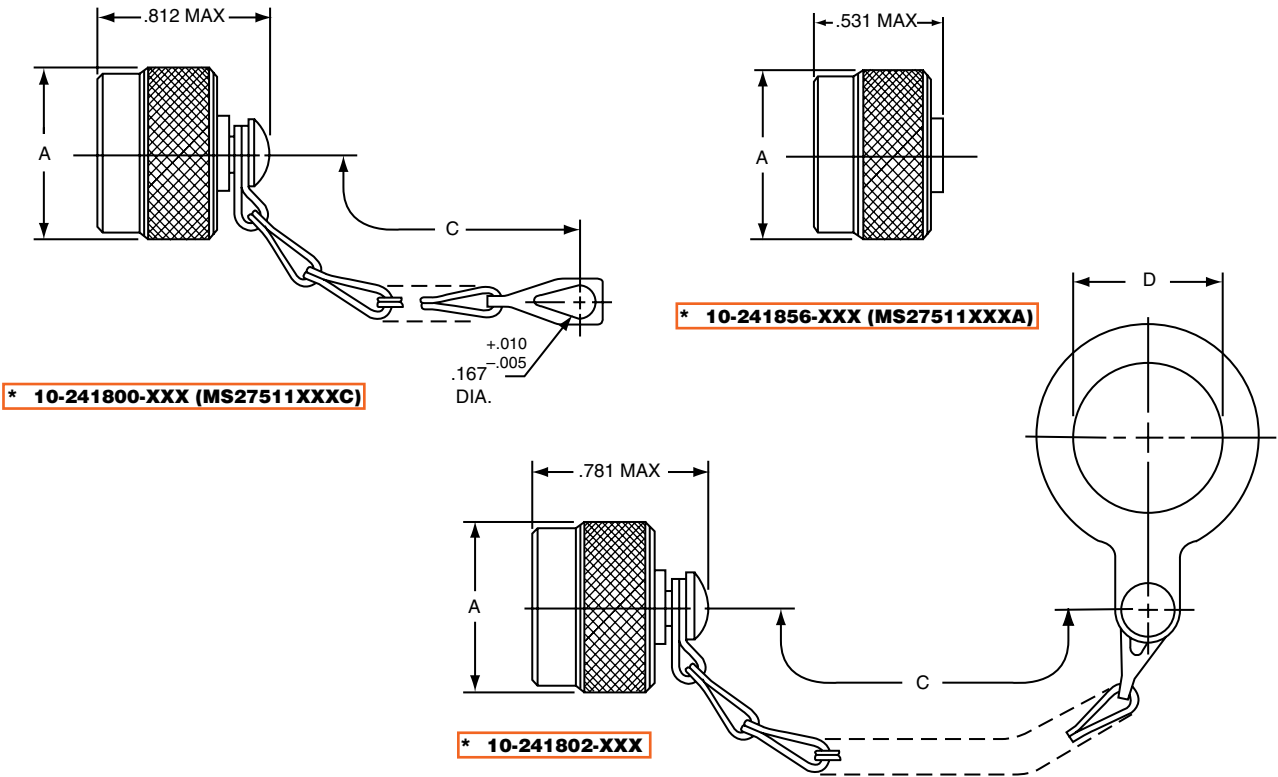

\* 10-241800-XXX (MS27511XXXC)

\* 10-241856-XXX (MS27511XXXA)

\* 10-241802-XXX

For MS stamping identification, accessories must be ordered by MS part number.

If ordered by 10- part number, they will be stamped with said number.

\* To complete order number, add shell size and suffix number.

For example, shell size 10 with cadmium plate, nickel base would be 10-241802-107, MS27511A10C, MS27511A10A

| Shell Size | A Dia. Max. | C Approx. | D +.010<br>-.000 |
|------------|-------------|-----------|------------------|
| 8          | .719        | 3.000     | .891             |
| 10         | .844        | 3.000     | 1.016            |
| 12         | 1.000       | 3.500†    | 1.141            |
| 14         | 1.125       | 3.500     | 1.266            |
| 16         | 1.250       | 3.500     | 1.391            |
| 18         | 1.375       | 3.500     | 1.516            |
| 20         | 1.500       | 4.000     | 1.641            |
| 22         | 1.625       | 4.000     | 1.766            |
| 24         | 1.750       | 4.000     | 1.891            |

†3.000 for MS27511

All dimensions for reference only.

| Finish                           | 10-Number Suffix | MS Number Suffix with chain | MS Number Suffix without chain |
|----------------------------------|------------------|-----------------------------|--------------------------------|
| Chromate treat                   | -XX0             |                             |                                |
| Anodic Coating                   | -XX5             | CXXC                        | CXXA                           |
| Cadmium Plate Nickel Base        | -XX7             | AXXC                        | AXXA                           |
| Olive Drab, Cadmium, Nickel base | -XX9             | BXXC                        | BXXA                           |
| Electroless nickel               | -XXG             | FXXC                        | FXXA                           |

- III 38999
- II
- I
- SJT
- Matrix 2 26482
- Matrix 83723 III
- Pyle 5015
- Crimp Rear Release Matrix 26500 Pyle
- Printed Circuit Board
- EML Filter Transient
- Fiber Optics
- High Speed Contacts
- Options Others

Strain relief (crimp type)

Series II JT

Series I LJT

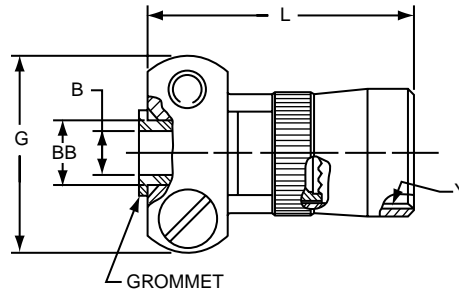

\* 10-405982-XXX (MS27506XXX-2 reference M85049/49)

For MS stamping identification, accessories must be ordered by MS part number.

If ordered by 10-part number, they will be stamped with said number.

\*To complete order number, add shell size and suffix number.

| Finish                           | 10-Number Suffix | MS27506 Suffix | M85049/49 Suffix |
|----------------------------------|------------------|----------------|------------------|
| Chromate treat                   | -XX0             |                | NA               |
| Anodic coating                   | -XX5             | CXX-2          | (-2-XXA)         |
| Cadmium plate nickel base        | -XX7             | AXX-2          | NA               |
| Olive drab, cadmium, nickel base | -XX9             | BXX-2          | (-2-XXW)         |
| Electroless nickel               | -XXG             | FXX-2          | (-2-XXN)         |

For example: Shell size 10 with cadmium plate, nickel base would be

10-405982-107 or M85049/49-2-10W

| Shell Size | B Dia. +.010-.025 | G Max. | L Max. | Y Thread (Modified) |                     | BB Dia. +.000 -.011 | Screw Size |
|------------|-------------------|--------|--------|---------------------|---------------------|---------------------|------------|
|            |                   |        |        | Size Class 2B       | Modified Minor Dia. |                     |            |
| 8          | .125              | .775   | .984   | .4375-28UNEF        | .399 - .405         | .250                | 6-32UNC    |
| 10         | .188              | .837   | .984   | .5625-24UNEF        | .524 - .529         | .312                | 6-32UNC    |
| 12         | .312              | .963   | .984   | .6875-24UNEF        | .649 - .654         | .438                | 6-32UNC    |
| 14         | .375              | 1.087  | 1.234  | .8125-20UNEF        | .766 - .771         | .562                | 6-32UNC    |
| 16         | .500              | 1.150  | 1.234  | .9375-20UNEF        | .891 - .896         | .625                | 6-32UNC    |
| 18         | .625              | 1.400  | 1.234  | 1.0625-18UNEF       | 1.002 - 1.007       | .750                | 8-32UNC    |
| 20         | .625              | 1.400  | 1.234  | 1.1875-18UNEF       | 1.135 - 1.140       | .750                | 8-32UNC    |
| 22         | .750              | 1.587  | 1.359  | 1.3125-18UNEF       | 1.252 - 1.257       | .938                | 8-32UNC    |
| 24         | .800              | 1.681  | 1.281  | 1.4375-18UNEF       | 1.377 - 1.382       | 1.000               | 8-32UNC    |

All dimensions for reference only.

Note: For solder type cable clamp 10-241055-XXX (M85049/49) consult Amphenol, Sidney, NY.



# MIL-DTL-38999, Series I LJT Plug Protection Cap

Series I LJT

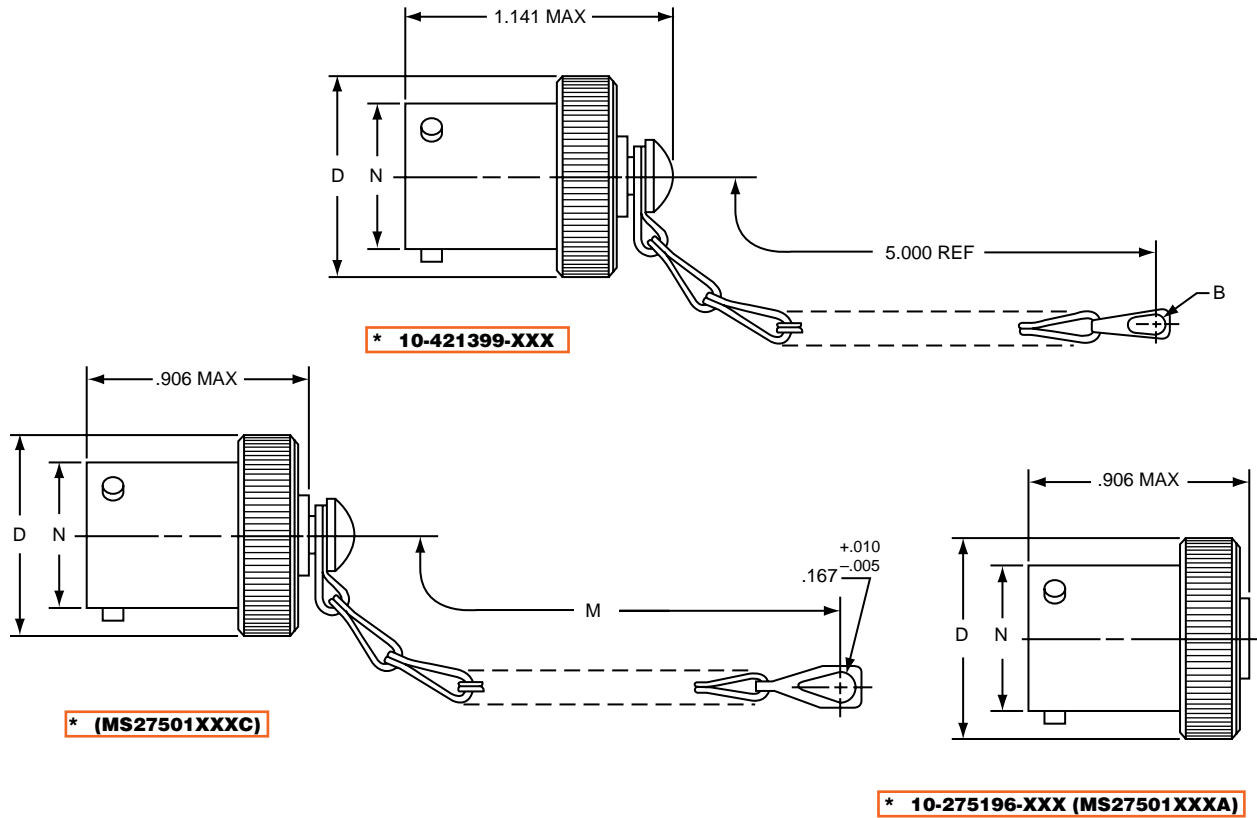

- III 38999 I SJT
- Matrix 2 26482
- Matrix Pyle 83723 III
- Crimp Rear Release Matrix 5015
- Pyle 26500
- Printed Circuit Board
- EMI Filter Transient
- Fiber Optics
- High Speed Contacts
- Options Others

\*To complete order number, add shell size and suffix number.

For example, shell size 11 with cadmium plate, nickel base would be [10-421399-117, MS27501A11C, MS27501A11A.](#)

| Shell Size | B Dia. Ref | D Dia. Max. | M ±.250 | N Dia. +.001 - .005 |
|------------|------------|-------------|---------|---------------------|
| 9          | .180       | .812        | 3.000   | .572                |
| 11         | .180       | .938        | 3.000   | .700                |
| 13         | .180       | 1.062       | 3.500   | .850                |
| 15         | .180       | 1.188       | 3.500   | .975                |
| 17         | .180       | 1.312       | 3.500   | 1.100               |
| 19         | .209       | 1.438       | 3.500   | 1.207               |
| 21         | .209       | 1.562       | 4.000   | 1.332               |
| 23         | .209       | 1.688       | 4.000   | 1.457               |
| 25         | .209       | 1.812       | 4.000   | 1.582               |

| Finish                           | 10- Number Suffix | MS Number Suffix with chain | MS Number Suffix without chain |
|----------------------------------|-------------------|-----------------------------|--------------------------------|
| Chromate treat                   | -XX0              |                             |                                |
| Anodic coating                   | -XX5              |                             |                                |
| Cadmium Plate Nickel base        | -XX7              | AXXC                        | AXXA                           |
| Olive Drab, Cadmium, Nickel base | -XX9              | BXXC                        | BXXA                           |
| Electroless nickel               | -XXG              | FXXC                        | FXXA                           |

All dimensions for reference only.

**Series I LJT**

38999  
SJT I II III

26482  
Matrix 2

83723 III  
Matrix Pyle

5015  
Crimp Rear  
Release Matrix

26500 Pyle

Printed  
Circuit Board

EMI Filter  
Transient

Fiber Optics

High Speed  
Contacts

Options  
Others

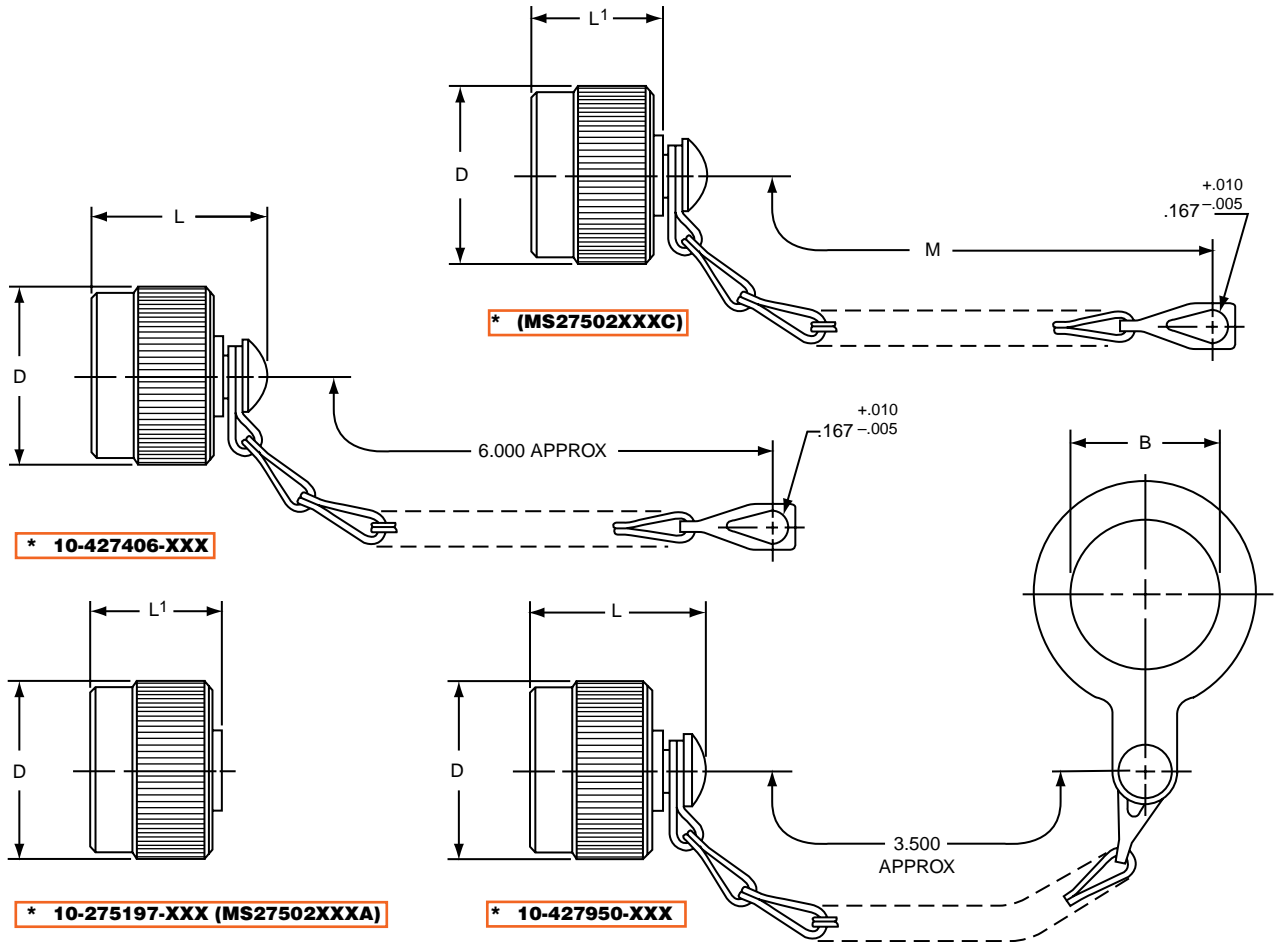

For MS stamping identification, accessories must be ordered by MS part number.  
If ordered by 10- part number, they will be stamped with said number.

\*To complete order number, add shell size and suffix number.

For example, shell size 11 with cadmium plate, nickel base would be 10-427406-117, MS27502A11C, MS27502A11A.

| Shell Size | B Dia. +.010 - .000 | D Dia. Max. | L Max. | L' Max | M ±.250 | Finish                           | 10-Number Suffix | MS Number Suffix with chain | MS Number Suffix without chain |
|------------|---------------------|-------------|--------|--------|---------|----------------------------------|------------------|-----------------------------|--------------------------------|
| 9          | .703                | .844        | 1.070  | .844   | 3.000   | Chromate treat                   | -XX0             |                             |                                |
| 11         | .844                | .969        | 1.070  | .844   | 3.000   | Anodic coating                   | -XX5             | CXXC                        | CXXA                           |
| 13         | 1.016               | 1.125       | 1.070  | .844   | 3.500   | Cadmium Plate Nickel base        | -XX7             | AXXC                        | AXXA                           |
| 15         | 1.141               | 1.250       | 1.070  | .844   | 3.500   | Olive Drab, Cadmium, Nickel base | -XX9             | BXXC                        | BXXA                           |
| 17         | 1.266               | 1.406       | 1.070  | .844   | 3.500   | Electroless Nickel               | -XXG             | FXXC                        | FXXA                           |
| 19         | 1.391               | 1.500       | 1.070  | .844   | 3.500   |                                  |                  |                             |                                |
| 21         | 1.516               | 1.625       | 1.070  | .844   | 4.000   |                                  |                  |                             |                                |
| 23         | 1.641               | 1.750       | 1.070  | .844   | 4.000   |                                  |                  |                             |                                |
| 25         | 1.766               | 1.875       | 1.089  | .875   | 4.000   |                                  |                  |                             |                                |

All dimensions for reference only.

# MIL-DTL-38999, Series I LJT Strain Relief (Solder Type)

Series I LJT

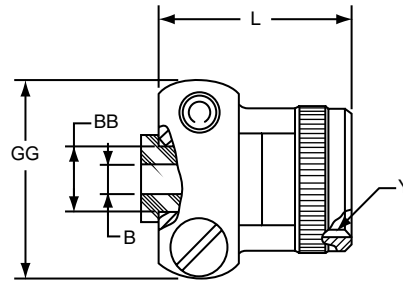

\* 10-436792-XXX

For military type cable clamp see MS27506 or M85049/49 on page 98.

\*To complete order number, add shell size and suffix number.

| Finish                           | 10-Number Suffix |
|----------------------------------|------------------|
| Chromate treat                   | -XX0             |
| Anodic coating                   | -XX5             |
| Cadmium Plate Nickel base        | -XX7             |
| Olive Drab, Cadmium, Nickel base | -XX9             |
| Electroless Nickel               | -XXG             |

For example: Shell size 11 with cadmium plate, nickel base would be 10-436792-117.

| Shell Size | B Dia. +.010<br>-.025 | L Max. | Y Thread Class 2B (Plated) | GG Max. | BB Dia. +.000<br>-.011 |
|------------|-----------------------|--------|----------------------------|---------|------------------------|
| 9          | .125                  | .859   | .4375-28 UNEF              | .775    | .250                   |
| 11         | .188                  | .859   | .5625-24 UNEF              | .837    | .312                   |
| 13         | .312                  | .859   | .6875-24 UNEF              | .963    | .438                   |
| 15         | .375                  | 1.109  | .8125-20 UNEF              | 1.087   | .562                   |
| 17         | .500                  | 1.109  | .9375-20 UNEF              | 1.150   | .625                   |
| 19         | .625                  | 1.109  | 1.0625-18 UNEF             | 1.400   | .750                   |
| 21         | .625                  | 1.109  | 1.1875-18 UNEF             | 1.400   | .750                   |
| 23         | .750                  | 1.234  | 1.3125-18 UNEF             | 1.587   | .938                   |
| 25         | .800                  | 1.234  | 1.4375-18 UNEF             | 1.681   | 1.000                  |

All dimensions for reference only.

III  
II  
I  
SJT

38999  
26482  
Matrix 2

83723 III  
Matrix  
Pyle

5015  
Crimp Rear  
Release Matrix

26500 Pyle

Printed  
Circuit Board

EMI Filter  
Transient

Fiber Optics

High Speed  
Contacts

Options  
Others

**Series II JT**

**Series I LJT**

**JT/LJT Crimp Contacts**

| Contact Size | Pins (JT/LJT) MS No. | JT Sockets MS. No | LJT Sockets MS. No |
|--------------|----------------------|-------------------|--------------------|
| 8 (Coax)*    | M39029/60-367        | NA                | M39029/59-366      |
| 8 (Twinax)   | M39029/90-529***     | NA                | M39029/91-530      |
| 10 (Power)   | M39029/58-528        | NA                | M39029/56-527      |
| 12           | M39029/58-365        | M39029/57-359     | M39029/56-353      |
| 16           | M39029/58-364        | M39029/57-358     | M39029/56-352      |
| 20           | M39029/58-363        | M39029/57-357     | M39029/56-351      |
| 22           | M39029/58-362        | M39029/57-356     | M39029/56-350      |
| 22M          | M39029/58-361        | M39029/57-355     | M39029/56-349      |
| 22D          | M39029/58-360        | M39029/57-354     | M39029/56-348      |

**THERMOCOUPLE CONTACTS**

| Contact Size | Material   | JT/LJT Pins   | JT Sockets    | LJT Sockets   |
|--------------|------------|---------------|---------------|---------------|
| 20           | Chromel    | 10-407862-310 | 10-407863-310 | 10-407236-310 |
|              | Alumel     | 10-407862-320 | 10-407863-320 | 10-407865-320 |
|              | Iron       | 10-407862-335 | 10-407863-335 | 10-407865-335 |
|              | Constantan | 10-407862-342 | 10-407863-342 | 10-407865-342 |

Partial Listing. If you do not see the contact for your application, consult Amphenol Aerospace, Sidney, N.Y.

**THERMOCOUPLE CONTACTS PYLE VERSION**

| Contact Size | Pins (JT/LJT) |             | Sockets (LJT) |             | Material |
|--------------|---------------|-------------|---------------|-------------|----------|
|              | Spec Number   | Pyle Number | Spec Number   | Pyle Number |          |
| 22D          | M39029/87-472 | T3-4022-10P | M39029/88-484 | T3-4122-10P | CHROMEL  |
| 22D          | M39029/87-471 | T3-4022-10R | M39029/88-483 | T3-4122-10R | ALUMEL   |
| 20           | M39029/87-476 | T3-4020-10P | M39029/88-488 | TS-4120-10P | CHROMEL  |
| 20           | M39029/87-475 | T3-4020-10R | M39029/88-487 | T3-4120-10R | ALUMEL   |
| 16           | M39029/87-480 | T3-4016-10P | M39029/88-492 | T3-4116-10P | CHROMEL  |
| 16           | M39029/87-479 | T3-4016-10R | M39029/88-491 | T3-4116-10R | ALUMEL   |

**PLASTIC PROTECTION CAPS**

| Shell Size | Plug         | Receptacle   |
|------------|--------------|--------------|
| 8          | 10-70500-10  | 10-70506-10S |
| 9          | 10-70506-14  | 10-70500-10  |
| 10         | 10-70506-14  | 10-70506-12  |
| 11         | 10-70506-16  | 10-70500-12  |
| 12         | 10-70506-16  | 10-70506-14  |
| 13         | 10-70506-18  | 10-70500-14  |
| 14         | 10-70506-18  | 10-70506-16  |
| 15         | 10-70506-20  | 10-70500-16  |
| 16         | 10-70506-20  | 10-70506-18  |
| 17         | 10-70506-22  | 10-70500-18  |
| 18         | 10-70506-22  | 10-70506-20  |
| 19         | 10-70506-24  | 10-70500-20  |
| 20         | 10-70506-24  | 10-70506-22  |
| 21         | 10-70576-24  | 10-70500-22  |
| 22         | 10-70576-24  | 10-70506-24  |
| 23         | 10-70506-28  | 10-70500-24  |
| 24         | 10-70506-28  | 10-70576-24  |
| 25         | 10-558651-25 | 10-70506-28  |

**SEALING PLUGS**

| Contact Size | Commercial No. | Military No. |
|--------------|----------------|--------------|
| 8 (Coax)     | 10-482099-8    | MS27488-8    |
| 8 (Twinax)   | T3-4008-59P    | N/A          |
| 10 (Power)   | 10-576225      | N/A          |
| 12           | 10-405996-12   | MS27488-12   |
| 16           | 10-405996-16   | MS27488-16   |
| 20           | 10-405996-20   | MS27488-20   |
| 22           | 10-405996-22   | MS27488-22   |
| 22M          | 10-405996-22   | MS27488-22   |
| 22D          | 10-405996-22   | MS27488-22   |

38999  
SJT I II III

26482  
Matrix 2

83723 III  
Matrix Pyle

5015  
Crimp Rear Release Matrix

26500 Pyle

Printed  
Circuit Board

EMI Filter  
Transient

Fiber Optics

High Speed  
Contacts

Options  
Others

SJT

### PLUG PROTECTION CAP

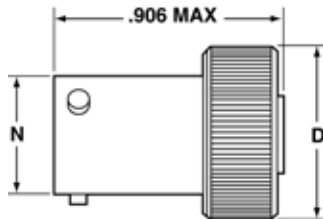

\*10-476801-XXX

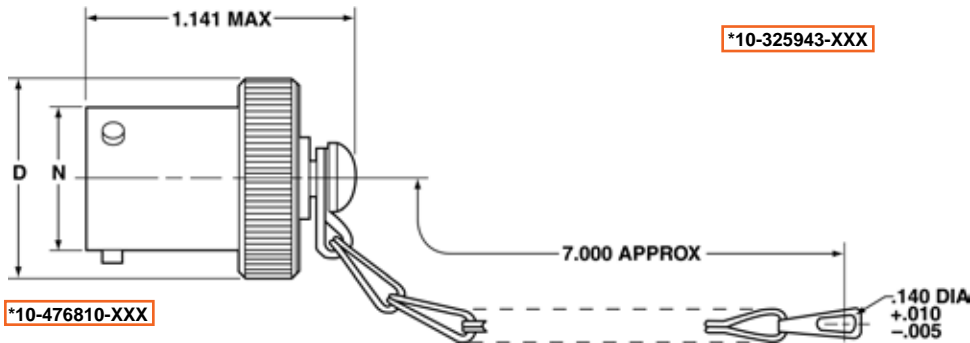

\*10-476810-XXX

### RECEPTACLE PROTECTION CAP

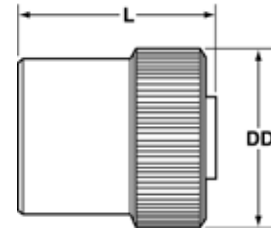

\*10-325943-XXX

\*To complete order number, add shell size and suffix number. For example, shell size 10 with bright cadmium plated nickel base, [10-476810-107](#).

| Plug Shell Size | D Dia. Max. | N Dia. +.001 - .005 |
|-----------------|-------------|---------------------|
| 8               | .688        | .473                |
| 10              | .812        | .590                |
| 12              | .969        | .750                |
| 14              | 1.094       | .875                |
| 16              | 1.219       | 1.000               |
| 18              | 1.344       | 1.125               |
| 20              | 1.469       | 1.250               |
| 22              | 1.594       | 1.375               |
| 24              | 1.719       | 1.500               |

All dimensions for reference only

\*To complete order number, add shell size and suffix number. For example, shell size 10 with bright cadmium plated nickel base, [10-325943-107](#).

| Receptacle Shell Size | DD Dia. Max. | L Max. |
|-----------------------|--------------|--------|
| 8                     | .734         | .828   |
| 10                    | .844         | .828   |
| 12                    | 1.016        | .828   |
| 14                    | 1.141        | .828   |
| 16                    | 1.265        | .828   |
| 18                    | 1.391        | .828   |
| 20                    | 1.500        | .828   |
| 22                    | 1.625        | .828   |
| 24                    | 1.750        | .859   |

Finish  
 Bright Cadmium Plated Nickel Base  
 Anodic Coating (Alumilite)  
 Chromate Treated (Iridite 14-2)  
 Olive Drab Cadmium Plate Nickel Base  
 Electroless Nickel Coating

Suffix  
 XX7  
 XX5  
 XX0  
 XX9  
 XXG

38999  
 III  
 II  
 I  
**SJT**

26482  
 Matrix 2

83723 III  
 Matrix  
 Pyle

5015  
 Crimp Rear  
 Release Matrix

26500 Pyle

Printed  
 Circuit Board

EMI Filter  
 Transient

Fiber Optics

High Speed  
 Contacts

Options  
 Others

SJT

### DUMMY RECEPTACLE

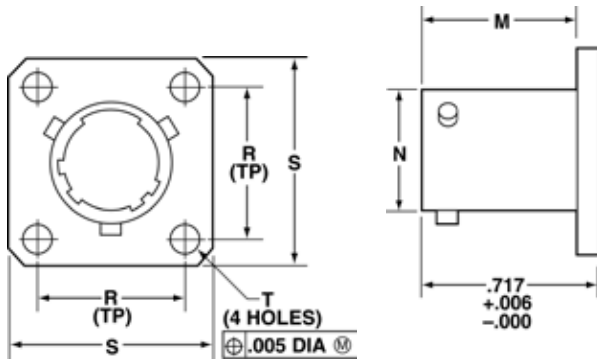

\*10-476807-XXX

| Finish                               | Suffix |
|--------------------------------------|--------|
| Bright Cadmium Plated Nickel Base    | XX7    |
| Anodic Coating (Alumilite)           | XX5    |
| Chromate Treated (Iridite 14-2)      | XX0    |
| Olive Drab Cadmium Plate Nickel Base | XX9    |
| Electroless Nickel Coating           | XXG    |

\* To complete order number, add shell size and suffix number. For example, shell size 10 with bright cadmium plated nickel base, 10-476807-107.

| Dummy Receptacle Shell Size | D Dia. Max. | L Max. |
|-----------------------------|-------------|--------|
| 8                           | .734        | .828   |
| 10                          | .844        | .828   |
| 12                          | 1.016       | .828   |
| 14                          | 1.141       | .828   |
| 16                          | 1.265       | .828   |
| 18                          | 1.391       | .828   |
| 20                          | 1.500       | .828   |
| 22                          | 1.625       | .828   |
| 24                          | 1.750       | .859   |

All dimensions for reference only

### CABLE CLAMP

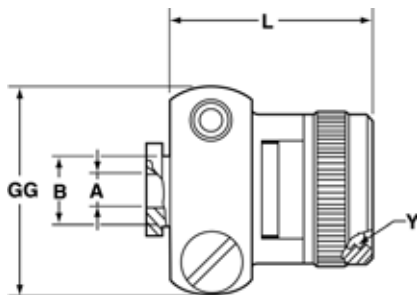

\*10-476808-XXX

| Finish                               | Suffix |
|--------------------------------------|--------|
| Bright Cadmium Plated Nickel Base    | XX7    |
| Anodic Coating (Alumilite)           | XX5    |
| Chromate Treated (Iridite 14-2)      | XX0    |
| Olive Drab Cadmium Plate Nickel Base | XX9    |
| Electroless Nickel Coating           | XXG    |

\* To complete order number, add shell size and suffix number. For example, shell size 10 with bright cadmium plated nickel base, 10-476808-107.

| Cable Clamp Shell Size | A Dia. +.010 - .025 | B Dia. +.000 - .011 | L Max. | Y Thread Class 2B UNEF (Plated) | GG Max. |
|------------------------|---------------------|---------------------|--------|---------------------------------|---------|
| 8                      | .125                | .250                | .922   | .4375-28                        | .775    |
| 10                     | .188                | .312                | .922   | .5625-24                        | .837    |
| 12                     | .312                | .438                | .922   | .6875-24                        | .963    |
| 14                     | .375                | .562                | 1.172  | .8125-20                        | 1.087   |
| 16                     | .500                | .625                | 1.172  | .9375-20                        | 1.150   |
| 18                     | .625                | .750                | 1.172  | 1.0625-18                       | 1.400   |
| 20                     | .625                | .750                | 1.172  | 1.1875-18                       | 1.400   |
| 22                     | .750                | .938                | 1.297  | 1.3125-18                       | 1.587   |
| 24                     | .800                | 1.000               | 1.297  | 1.4375-18                       | 1.681   |

All dimensions for reference only



SJT

38999  
III  
II  
I  
SJT

26482  
Matrix 2

83723 III  
Matrix  
Pyle

5015  
Crimp Rear  
Release Matrix

26500 Pyle

Printed  
Circuit Board

EMI Filter  
Transient

Fiber Optics

High Speed  
Contacts

Options  
Others

### CONTACTS & SEALING PLUGS

| Contact Size | SJT Pins      | SJT Sockets                      | Sealing Plugs       |
|--------------|---------------|----------------------------------|---------------------|
| 8 (Coax)     | 21-33102-21** | 21-33101-21**                    | 10-482099-8         |
| 8 (Twinax)   | 21-33190-529† | 21-33191-530†                    | 10-482099-8         |
| 10 (Power)   | 10-251415-105 | 10-407035-105                    | Not Available       |
| 12           | 10-251415-12H | 10-407035-125                    | 10-405996-12 Yellow |
| 16           | 10-251415-165 | 10-407035-165                    | 10-405996-16 Blue   |
| 20           | 10-251415-205 | 10-407035-205<br>10-497403-205†† | 10-405996-20 Red    |
| 22*          | 10-251415-225 | 10-407035-225                    | 10-405996-22 Black  |
| 22M*         | 10-251415-235 | 10-407035-235                    | 10-405996-22 Black  |
| 22D          | 10-251415-725 | 10-407035-725                    | 10-405996-22 Black  |

Above part numbers include standard finish designation – gold plating over suitable underplate in accordance with SAE AS39029. For other finish variations, consult Amphenol, Sidney, NY.

\* Inactive for new design.

\*\* 21-33102-21 and 21-33101-21 are for use with RG180B/U and RG195A/U cable. For other size 8 coax or optional sizes 12 and 16 coax contacts available for use in SJT connectors, see catalog 12-130 or consult Amphenol, Sidney, NY.

† 21-33190-529 and 21-33191-530 are for use with M17/176-00002 cable.

†† Optional design – see slash sheet MS39029.

For other contact options available for use in SJT connectors, (wire-wrap, thermocouple, fiber optic) consult Amphenol, Sidney, NY.

### PLASTIC PROTECTION CAPS

| Shell Size | Plug        | Receptacle   |
|------------|-------------|--------------|
| 8          | 10-70500-10 | 10-70506-10S |
| 10         | 10-70500-14 | 10-70506-12  |
| 12         | 10-70500-16 | 10-70506-14  |
| 14         | 10-70500-18 | 10-70506-16  |
| 16         | 10-70500-20 | 10-70506-18  |
| 18         | 10-70500-22 | 10-70506-20  |
| 20         | 10-70500-24 | 10-70506-22  |
| 22         | 10-70524-1  | 10-70506-24  |
| 24         | 10-70506-28 | 10-70524-1   |

for Flex Print or PC Board

Series III TV

Series II JT

Series I LJT

**Mounts to all MIL-DTL-38999 and  
\*MIL-DTL-26482 Connectors**

Termination of PC tail connectors to a flex print or a printed circuit board represents a major cost in the manufacturing process for users. When adding flex or printed circuit board assemblies to an expensive filter or filter/transient protection connector, the total cost of a failed solder joint, a bent pin, or an unanticipated electrical failure becomes prohibitive. The universal header assembly from Amphenol provides for easy separation of the connector from the board on these occasions. The header assembly is comprised of a short pin/socket contact. The tail end of the contact is soldered to the through hole of the flex or printed circuit board. The socket is embedded in the insulator, making electrical contact with the printed circuit tail of the connector.

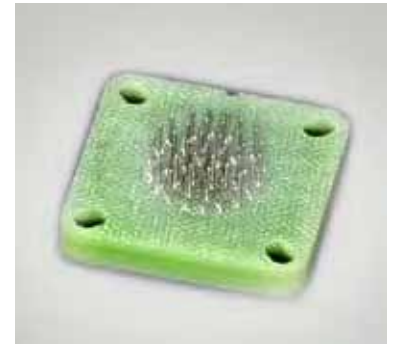

**Headers provide easy separation of the connector from the PC board.**

**Header Assemblies Provide Cost Savings**

Incorporation of the header assembly provides the user with time and cost saving potentials. These header assemblies can be vapor phase or wave soldered to flex or printed circuit boards prior to the receipt of the EMI/EMP connector. Headers can be installed to standard connectors, allowing for electrical testing that would adversely affect the sensitive diodes, MOV's or capacitors in the EMI/EMP connectors. Expensive connector assemblies can be easily removed from and reattached to the header assembly as the manufacturing process dictates.

**Mounting Applications**

Shell modifications are recommended, but are not necessary. The header assembly can be attached to connectors with standard flange placement or directly to the circuit board. The ideal application would involve either a single flange moved all the way to the rear of the connector or a double flange. Cinch nuts can be installed in either flange to allow easier mounting to the panel or the header assembly. The forward flange would mount the connector to the panel; the rear flange would be used to mount the header assembly. Various types of captivated or loose attaching screws can be utilized for unique applications.

Amphenol universal headers are slotted to allow mounting to all series of MIL-DTL-38999 or MIL-DTL-26482\* connectors without special alterations. They are of similar dimension as the flange of the mounting connector and are approximately .185 inches (4.70 mm) thick.

\* For information on Header Assemblies for MIL-DTL-26482 connector consult Amphenol, Sidney NY.

**Cylindrical Configuration**

- 3 PCB stickout dimensions are available.
- Size 22 contacts use .175 thick headers
- Size 16 to 20 contacts use .195 thick headers
- Consult Amphenol, Sidney NY for additional configurations.
- Headers for cylindrical connectors accommodate up to 128 pins. For MIL-DTL-38999 insert arrangements chart see pages 4-7 and insert drawings on pages 8-14.

**Mounting to Rectangular ARINC Connectors**

- Headers for ARINC connector arrangements accommodate up to 150 pins
- Consult Amphenol, Sidney, NY for ARINC configurations and detailed dimensions.

**Materials**

- Body is molded or machined from FR-4.
- Electrical engagement areas of the header contact are plated with .00003 inches minimum of gold over .00005 inches minimum of nickel.

See drawing of standard header on next page.

38999  
SJT

26482  
Matrix 2

83723 III  
Matrix Pyle

5015  
Crimp Rear Release Matrix

26500 Pyle

Printed  
Circuit Board

EMI Filter  
Transient

Fiber Optics

High Speed  
Contacts

Options  
Others

# MIL-DTL-38999, Series III TV, II JT, I LJT

## Universal "Header Assembly" for Flex Print or PC Board Connectors



The drawing below shows the standard header assembly for use with MIL-DTL-38999 connectors. Consult Amphenol Aerospace, Sidney NY for drawings of headers for ARINC configurations.

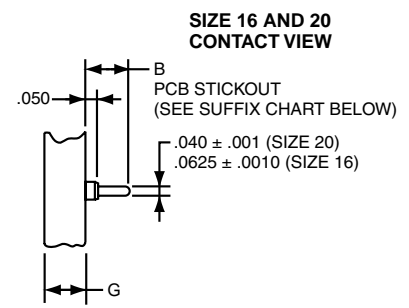
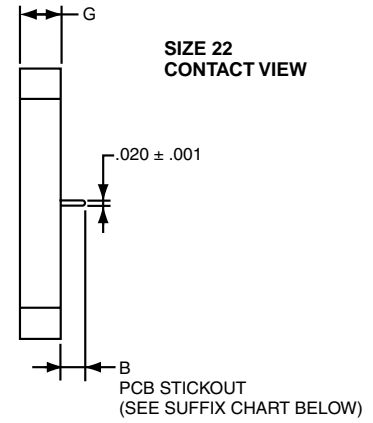
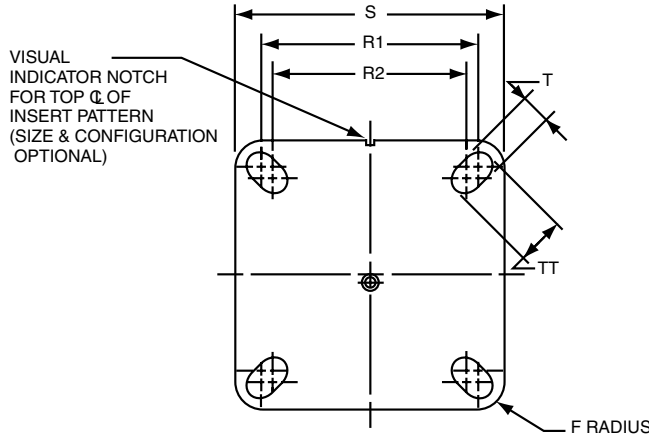

| Assembly Part Number | Shell Size | F Radius | G ± .005 | S ± .005 | T + .008 - .006 | R1 TP† | R2 TP† | TT + .008 - .006 |
|----------------------|------------|----------|----------|----------|-----------------|--------|--------|------------------|
| 21-904008-XX()       | 8/9        | .094     |          | .938     | .128            | .719   | .594   | .216             |
| 21-904010-XX()       | 10/11      | .094     |          | 1.031    | .128            | .812   | .719   | .194             |
| 21-904012-XX()       | 12/13      | .094     |          | 1.125    | .128            | .906   | .812   | .194             |
| 21-904014-XX()       | 14/15      | .125     |          | 1.219    | .128            | .969   | .906   | .173             |
| 21-904016-XX()       | 16/17      | .125     |          | 1.312    | .128            | 1.062  | .969   | .194             |
| 21-904018-XX()       | 18/19      | .125     |          | 1.438    | .128            | 1.156  | 1.062  | .194             |
| 21-904020-XX()       | 20/21      | .125     |          | 1.562    | .128            | 1.250  | 1.156  | .194             |
| 21-904022-XX()       | 22/23      | .125     |          | 1.688    | .154            | 1.375  | 1.250  | .242             |
| 21-904024-XX()       | 24/25      | .125     |          | 1.812    | .154            | 1.500  | 1.375  | .242             |

See Suffix Chart

Assemblies containing Size 22 contacts only: .175  
Assemblies containing Size 16 or 20 contacts: .195

† TP designates true position dimensioning.

NOTE:  
Size 22 accepts .018 to .022 dia. PCB tails.  
Size 16 accepts .048 to .064 dia. PCB tails.  
Size 20 accepts .037 to .043 dia. PCB tails.

### HOW TO ORDER INFORMATION

#### For Header Assembly with MIL-DTL-38999 Connectors

Use coded number as follows:

**21-9040 XX - XX X**

Designates Amphenol Header Assembly \_\_\_\_\_  
Shell size designation for MIL-DTL-38999 Series I, II, III and IV see Suffix chart. \_\_\_\_\_  
Arrangement number - See MIL-STD-1560 or MIL-STD-1669. See insert availability charts on pages 4-7. \_\_\_\_\_  
Contact PCB Stickout designation See Suffix chart. \_\_\_\_\_

For how to order information on adapters to be used with ARINC connectors, consult Amphenol, Sidney NY.

### ASSEMBLY NUMBER SUFFIX CHART

| Shell Size Designation* | Arrangement Number Suffix***                                | Contact PCB Stickout** |                   |
|-------------------------|---|------------------------|-------------------|
|                         |   | Suffix                 | B ± .015 Stickout |
| 08                      | Insert Arrangement Suffix from MIL-STD-1560 or MIL-STD-1669 | 1                      | .120              |
| 10                      |   | 2                      | .185              |
| 12                      |   | 3                      | .270              |
| 14                      |   |                        |                   |
| 16                      |   |                        |                   |
| 18                      |   |                        |                   |
| 20                      |   |                        |                   |
| 24                      |   |                        |                   |

\*Shell size designation for MIL-DTL-38999 Series I, II, III and IV and MIL-DTL-26482 Series 1 and 2.

Examples: Shell size 9 use 08. Shell size 25 use 24.

\*\* Size 22 contacts available in all 3 stickout lengths. Size 16 and 20 contacts available only in .185 and .270 lengths.

\*\*\* Insert arrangement 14-97 and 15-97 are not available at this time. Consult Amphenol, Sidney NY for information.



|               |              |              |     |
|---------------|--------------|--------------|-----|
| Series III TV | Series II JT | Series I LJT | SJT |
|---------------|--------------|--------------|-----|

The following data includes information pertaining to the application tools which have been established for crimping, inserting, and removing contacts incorporated in the TV, CTV and MIL-DTL-38999 Series III connectors. For additional information on coax, twinax and triax contact tools see High Speed Contact section of this catalog. All crimping tools included are the "full cycling" type and when

used as specified in the installation instructions (L-624 and L-844) covering the TV, CTV and MS series connectors, will provide reliable crimped wire to contact terminations. There is a possibility of additional crimping tools other than those included being available at present or in the future for this specific application.

### CRIMPING TOOLS

| Contact Size/Type                        | Crimping Tool                             | Turret Die or Positioner                  |
|--|---|---|
| 12 Pin and Socket                        | M22520/1-01                               | M22520/1-04                               |
| 16 Pin and Socket                        | M22520/1-01<br>M22520/7-01                | M22520/1-04<br>M22520/7-04                |
| 20 Pin and Socket                        | M22520/1-01<br>M22520/2-01<br>M22520/7-01 | M22520/1-04<br>M22520/2-10<br>M22520/7-08 |
| 22, 22D, 22M Pin                         | M22520/2-01<br>M22520/7-01                | M22520/2-09<br>M22520/7-07                |
| 22, 22D, 22M Socket Series I, III        | M22520/2-01<br>M22520/7-01                | M22520/2-07<br>M22520/7-05                |
| 22D Socket Series II                     | M22520/2-01<br>M22520/7-01                | M22520/2-06<br>M22520/7-06                |
| 8 Twinax Center Pin and Socket           | M22520/2-01                               | M22520/2-37                               |
| 8 Twinax Intermediate Outer Pin & Socket | M22520/5-01                               | M22520/5-200                              |

| Contact Size/Type               | Crimping Tool | Turret Die or Positioner   |
|---------------------------------|---------------|----------------------------|
| 8 Coaxial Inner Pin and Socket  | M22520/2-01   | M22520/2-31                |
| 8 Coaxial Outer Pin and Socket  | M22520/5-01   | M22520/5-05 Die Closure B  |
|                                 | M22520/5-01   | M22520/5-41 Die Closure B  |
|                                 | M22520/10-01  | M22520/10-07 Die Closure B |
| 16 Coaxial Inner Pin and Socket | M22520/2-01   | M22520/2-35                |
| 16 Coaxial Outer Pin and Socket | M22520/4-01   | M22520/4-02                |
| 12 Coaxial Inner Pin and Socket | M22520/2-01   | M22520/2-34                |
| 12 Coaxial Outer Pin and Socket | M22520/31-01  | M22520/31-02               |
| 10 (Power)                      | TP-201423     |                            |

Where 2 or 3 tools are listed for a contact size, only one tool and its die or positioner are required to crimp the contact. The above crimping tools and positioners are available from the approved tool manufacturer.

### INSERTION TOOLS

| Use with Contact Size | Plastic Tools  |                  |                | Metal Tools         |                                   |        |
|-----------------------|----------------|------------------|----------------|---------------------|-----------------------------------|--------|
|                       | MS Part Number | Color            | Angle Type     |                     | Straight Type Commercial Part No. | Color  |
|                       |                |                  | MS Part No.    | Commercial Part No. |                                   |        |
| 10 (Power)            | M81969/14-05*  | Gray / (White)   | M81969/8-11    | †                   | †                                 | Green  |
| 12                    | M81969/14-04*  | Yellow / (White) | M81969/8-09    | 11-8674-12          | 11-8794-12                        | Yellow |
| 16                    | M81969/14-03*  | Blue / (White)   | M81969/8-07    | 11-8674-16          | 11-8794-16                        | Blue   |
| 20                    | M81969/14-10*  | Red / (Orange)   | M81969/8-05    | 11-8674-20          | 11-8794-20                        | Red    |
| 22                    | M81969/14-09   | Brown/White      | M81969/8-03    | 11-8674-22          | 11-8794-22                        | Brown  |
| 22D, 22M              | M81969/14-01*  | Green / (White)  | M81969/8-01    | 11-8674-24          | 11-8794-24                        | Black  |
| 8 Coaxial             | None Required  |                  |                |                     |                                   |        |
| 8 Twinax              | None           |                  | M81969/46-06** | None                |                                   | Red    |

### REMOVAL TOOLS

| Use with Contact Size | Plastic Tools  |                  |  | Metal Tools    |                     |                                   |                |
|-----------------------|----------------|------------------|--|----------------|---------------------|-----------------------------------|----------------|
|                       | MS Part Number | Color            | For Unwired Contacts Commercial Part No. | Angle Type     |                     | Straight Type Commercial Part No. | Color          |
|                       |                |                  |  | MS Part No.    | Commercial Part No. |                                   |                |
| 10 (Power)            | M81969/14-05*  | (Gray) / White   | †  | M81969/8-12    | †                   | †                                 | Green / White  |
| 12                    | M81969/14-04*  | (Yellow) / White | 11-10050-11                              | M81969/8-10    | 11-8675-12          | 11-8795-12                        | Yellow / White |
| 16                    | M81969/14-03*  | (Blue) / White   | 11-10050-10                              | M81969/8-08    | 11-8675-16          | 11-8795-16                        | Blue / White   |
| 20                    | M81969/14-10*  | (Orange) / Red   | 11-10050-9                               | M81969/8-06    | 11-8675-20          | 11-8795-20                        | Red / Orange   |
| 22                    | M81969/14-09*  | (Brown)/White    | 11-10050-8                               | M81969/8-04    | 11-8675-22          | 11-8795-22                        | Brown/White    |
| 22D, 22M              | M81969/14-01*  | (Green) / White  | 11-10050-7                               | M81969/8-02    | 11-8675-24          | 11-8795-24                        | Green / White  |
| 8 Coaxial             | M81969/14-12   | Green            | None                                     | None           | 11-9170             | DRK264-8††                        | N/A            |
| 8 Twinax              | M81969/14-12   | Green            | None                                     | M81969/46-12** | 11-9170             | N/A                               | N/A            |

The M81969/8, 11-8674, 11-8675, and 11-8794 metal contact insertion and removal tools will accommodate wires having the maximum outside diameter as follows: Contact size 12: dia. is .155, size 16: dia. is .109, size 20: dia. is .077, size 22D: dia. is .050. When wire diameters exceed those specified, the plastic tools must be used.

\* Double end insertion/removal tool.

\*\* Twinax insertion tools are available only in a straight type, metal version.

† To be determined.

†† Contact Daniels Manufacturing Co. for availability.

38999 III II I SJT  
 26482 Matrix 2  
 83723 III Pyle Matrix  
 5015 Crimp Rear Release Matrix  
 26500 Pyle  
 Printed Circuit Board  
 EMI Filter Transient  
 Fiber Optics  
 High Speed Contacts  
 Options Others

# Amphenol MIL-DTL-26482, Series 2, Matrix<sup>®</sup>



## TABLE OF CONTENTS

### MIL-DTL-26482, Series 2, Matrix<sup>®</sup>

|   |          |
|---|----------|
| • Table of Contents . . . . .   | 109      |
| • Design Characteristics, Customer Options . . . . .                      | 110      |
| • Insert Availability and Identification, Alternate Positioning . . . . . | 111      |
| • Insert Arrangement Drawings . . . . .                                   | 112, 113 |
| • Class Descriptions, Performance Specifications . . . . .                | 114      |
| • How to Order (Military and Commercial) . . . . .                        | 115      |

### Shell Styles:

|  |     |
|--|-----|
| • Wall Mounting Receptacle with Narrow Flange, Wall Mounting Receptacle with Wide Flange . . . . . | 116 |
| • Cable Connecting Receptacle, Jam Nut Receptacle . . . . .  | 117 |
| • Straight Plug, Straight Plug with RFI Grounding Fingers . . . . .                                | 118 |

### Contacts and Tools:

|  |     |
|--|-----|
| • Contact Information, Sealing Plugs, Crimping and Insertion/Removal Tools . . . . . | 119 |
|--|-----|

### Additional MIL-DTL-26482 Connectors

|  |     |
|--|-----|
| • Brief Description of Commercial/Military MIL-DTL-26482, Series 1 . . . . . | 120 |
| (Covered in-depth in Amphenol Industrial Catalog 12-070)                     |     |



### MIL-DTL-26482 Series 2, Matrix<sup>®</sup> Typical Markets:

- Military & Commercial Aviation
  - Cockpit, Landing Gear, Aircraft Frame
- Military Aircraft Carriers
- Instrumentation/Process Control/Test Equipment
- C4ISR





38999  
SJT I II III

26482  
Matrix 2

83723 III  
Matrix Pyle

5015  
Crimp Rear Release Matrix

26500 Pyle

Printed  
Circuit Board

EMI Filter  
Transient

Fiber Optics

High Speed  
Contacts

Options  
Others

**Amphenol Aerospace offers the Matrix® Product line of MIL-DTL-26482\*, Series 2 connectors.**

This series provides a bayonet coupling connector with crimp rear insertable, rear releasable contacts.

**DESIGN CHARACTERISTICS**

- Medium size, environmentally resistant connector
- Recommended operating voltage to 1,000 VAC (RMS) at sea level
- Quick positive coupling assured by 3 point bayonet coupling system
- Visual confirmation of complete coupling
- Eliminates mismatching by the use of five key/keyway design
- Insertion and removal of contacts from the rear of the connector assures no damage to the front that might affect the sealing characteristics
- Utilizes same standard qualified rear-release type plastic tool for contact insertion and removal
- Contacts are qualified to SAE AS39029\*\* requirements – BIN coded (three color bands), and are crimped with standard crimp tools per MIL-DTL-22520
- Grommets are constructed of tear-resistant elastomer and experience no degradation when exposed to a broad range of fluids
- Sealing over a range of wire diameters is assured by a triple webbed grommet at the rear of the connector
- Closed entry socket side of the insert is designed with a lead-in chamfer and a hard face that will accept a pin contact bent within pre-established limits
- Elastomer interfacial seal on the pin side has raised barriers around each pin which displace into the socket chamfer when mated, providing a positive moisture seal

**CUSTOMER OPTIONS**

- Shell styles within this family include: Wall mount with either a narrow or a wide flange, jam nut single hole mount, and cable connecting receptacles, along with standard plugs or plugs with RFI grounding fingers, in shell sizes 8 to 24
- MS and Proprietary versions available
- Accommodation of contact sizes 20, 16 and 12
- 34 insert arrangement patterns available, accommodating from a minimum of 3 to a maximum of 55 circuits
- Alternate positioning available
- Various finishes are available (for information on non-cadmium zinc alloy plating, consult Amphenol Aerospace, Sidney, NY)

\* MIL-DTL-26482 supersedes MIL-C-26482

\*\* SAE AS39029 supersedes MIL-C-39029



**MS3470**  
wall mounting receptacle  
with narrow flange

**MS3472**  
wall mounting receptacle  
with wide flange

**MS3471**  
cable connecting  
receptacle

**MS3474**  
jam nut receptacle

**MS3476**  
straight plug  
**MS3475**  
plug with RFI grounding  
fingers



**INSERT ARRANGEMENTS**

| Insert Arrangement | Service Rating | Total Contacts | Contact Size |    |    |
|--------------------|----------------|----------------|--------------|----|----|
|                    |                |                | 12           | 16 | 20 |
| 8-33               | I              | 3              |              |    | 3  |
| 8-98               | I              | 3              |              |    | 3  |
| 10-6               | I              | 6              |              |    | 6  |
| 12-3               | II             | 3              |              | 3  |    |
| 12-8               | I              | 8              |              |    | 8  |
| 12-10              | I              | 10             |              |    | 10 |
| 14-4               | I              | 4              | 4            |    |    |
| 14-5               | II             | 5              |              | 5  |    |
| 14-9S              | I              | 9              | 4            |    | 5  |
| 14-12              | I              | 12             |              | 4  | 8  |
| 14-15              | I              | 15             |              | 1  | 14 |
| 14-18              | I              | 18             |              |    | 18 |
| 14-19              | I              | 19             |              |    | 19 |
| 16-8               | II             | 8              |              | 8  |    |
| 16-23S             | I              | 23             |              | 1  | 22 |
| 16-26              | I              | 26             |              |    | 26 |
| 18-8               | I              | 8              | 8            |    |    |
| 18-11S             | II             | 11             |              | 11 |    |
| 18-30S             | I              | 30             |              | 1  | 29 |
| 18-32              | I              | 32             |              |    | 32 |
| 20-16              | II             | 16             |              | 16 |    |
| 20-24S             | I              | 24             |              |    | 24 |
| 20-39              | I              | 39             |              | 2  | 37 |
| 20-41              | I              | 41             |              |    | 41 |
| 22-12S             | I              | 12             | 12           |    |    |
| 22-19S             | I              | 19             | 19           |    |    |
| 22-21              | II             | 21             |              | 21 |    |
| 22-32S             | I              | 32             |              |    | 32 |
| 22-41              | I              | 41             |              | 14 | 27 |
| 22-55              | I              | 55             |              |    | 55 |
| 22-95S             | I              | 32             | 6            |    | 26 |
| 24-19S             | II             | 19             | 19           |    |    |
| 24-31              | I              | 31             |              | 31 |    |
| 24-61              | I              | 61             |              |    | 61 |

Arrangements designated with an S are tooled in socket only.

**ALTERNATE ROTATIONS OF INSERT**

To avoid cross-plugging problems in applications requiring the use of more than one connector of the same size and arrangement, alternate rotations are available as indicated in the chart below.

As shown in the diagram, the front face of the pin insert is rotated within the shell in a clockwise direction from the normal shell key. The socket insert would be rotated counter-clockwise the same number of degrees in respect to the normal shell key.



View looking into front face of pin insert or rear of socket insert.

| Insert Arrangement | Degrees |     |     |     |
|--------------------|---------|-----|-----|-----|
|                    | W       | X   | Y   | Z   |
| 8-33               | 90      | -   | -   | -   |
| 8-98               | -       | -   | -   | -   |
| 10-6               | 90      | -   | -   | -   |
| 12-3               | -       | -   | 180 | -   |
| 12-8               | 90      | 112 | 203 | 292 |
| 12-10              | 60      | 155 | 270 | 295 |
| 14-4               | 45      | -   | -   | -   |
| 14-5               | 40      | 92  | 184 | 273 |
| 14-9               | 15      | 90  | 180 | 270 |
| 14-12              | 43      | 90  | -   | -   |
| 14-15              | 17      | 110 | 155 | 234 |
| 14-18              | 15      | 90  | 180 | 270 |
| 14-19              | 30      | 165 | 315 | -   |
| 16-8               | 54      | 152 | 180 | 331 |
| 16-23              | 158     | 270 | -   | -   |
| 16-26              | 60      | -   | 275 | 338 |
| 18-8               | 180     | -   | -   | -   |
| 18-11              | 62      | 119 | 241 | 340 |
| 18-30              | 180     | 193 | 285 | 350 |
| 18-32              | 85      | 138 | 222 | 265 |
| 20-16              | 238     | 318 | 333 | 347 |
| 20-24              | 70      | 145 | 215 | 290 |
| 20-39              | 63      | 144 | 252 | 333 |
| 20-41              | 45      | 126 | 225 | -   |
| 22-12              | -       | -   | -   | -   |
| 22-19              | 15      | 90  | 225 | 308 |
| 22-21              | 16      | 135 | 175 | 349 |
| 22-32              | 72      | 145 | 215 | 288 |
| 22-41              | 39      | 135 | 264 | -   |
| 22-55              | 30      | 142 | 226 | 314 |
| 22-95              | 26      | 180 | 266 | -   |
| 24-19              | 30      | 165 | 315 | -   |
| 24-31              | 90      | 225 | 255 | -   |
| 24-61              | 90      | 180 | 270 | 324 |

III  
II  
I  
SJT  
38999

26482  
Matrix 2

83723 III  
Matrix  
Pyle

5015  
Crimp Rear  
Release Matrix

26500 Pyle

Printed  
Circuit Board

EMI Filter  
Transient

Fiber Optics

High Speed  
Contacts

Options  
Others

front face of pin insert or rear face of socket insert illustrated

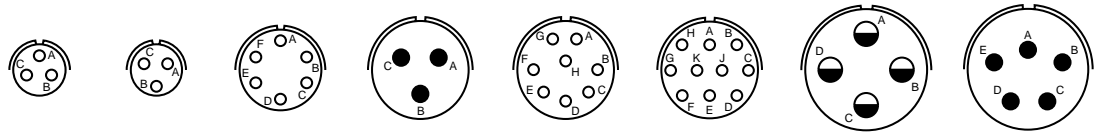

| Insert Arrangement | 8-33 | 8-98 | 10-06 | 12-03 | 12-08 | 12-10 | 14-04 | 14-05 |
|--------------------|------|------|-------|-------|-------|-------|-------|-------|
| Service Rating     | I    | I    | I     | II    | I     | I     | I     | II    |
| Number of Contacts | 3    | 3    | 6     | 3     | 8     | 10    | 4     | 5     |
| Contact Size       | 20   | 20   | 20    | 16    | 20    | 20    | 12    | 16    |

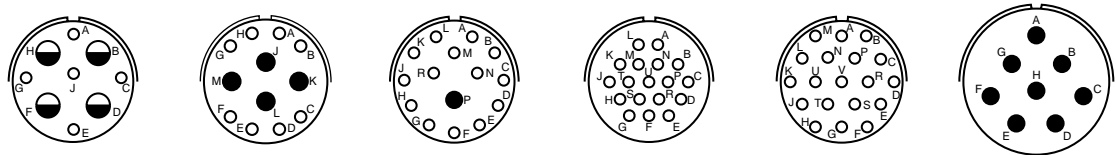

| Insert Arrangement | 14-09 |    | 14-12 |    | 14-15 |    | 14-18 | 14-19 | 16-08 |
|--------------------|-------|----|-------|----|-------|----|-------|-------|-------|
| Service Rating     | I     |    | I     |    | I     |    | I     | I     | II    |
| Number of Contacts | 5     | 4  | 8     | 4  | 14    | 1  | 18    | 19    | 8     |
| Contact Size       | 20    | 12 | 20    | 16 | 20    | 16 | 20    | 20    | 16    |



| Insert Arrangement | 16-23 |    | 16-26 |  | 18-08 | 18-11 |  | 18-30 |    |
|--------------------|-------|----|-------|--|-------|-------|--|-------|----|
| Service Rating     | I     |    | I     |  | I     | II    |  | I     |    |
| Number of Contacts | 22    | 1  | 26    |  | 8     | 11    |  | 29    | 1  |
| Contact Size       | 20    | 16 | 20    |  | 12    | 16    |  | 20    | 16 |

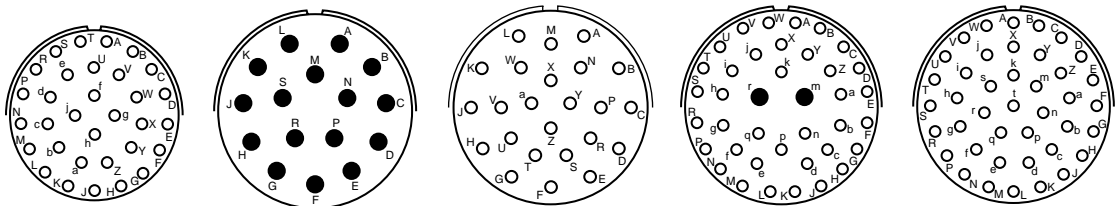

| Insert Arrangement | 18-32 |  | 20-16 |  | 20-24 | 20-39 |    | 20-41 |  |
|--------------------|-------|--|-------|--|-------|-------|----|-------|--|
| Service Rating     | I     |  | II    |  | I     | I     |    | I     |  |
| Number of Contacts | 32    |  | 16    |  | 24    | 37    | 2  | 41    |  |
| Contact Size       | 20    |  | 16    |  | 20    | 20    | 16 | 20    |  |

NOTE: Connectors sold as mil-spec connectors will have mil-spec markings on the insert (a "snail-trail" designating the numerical path). Commercial versions will have insert markings as shown here.

**CONTACT LEGEND**

|    |    |    |
|----|----|----|
| ○  | ●  | ◐  |
| 20 | 16 | 12 |

38999  
SJT I II III

26482  
Matrix 2

83723 III  
Matrix Pyle

5015  
Crimp Rear  
Release Matrix

26500 Pyle

Printed  
Circuit Board

EMI Filter  
Transient

Fiber Optics

High Speed  
Contacts

Options  
Others

front face of pin insert or rear face of socket insert illustrated

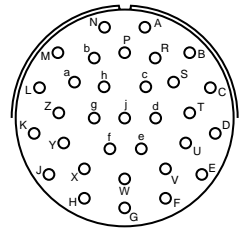
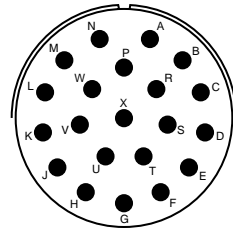
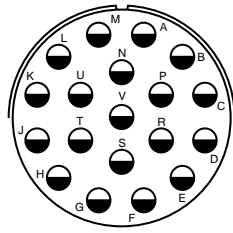
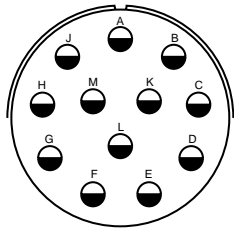

| Insert Arrangement | 22-12 | 22-19 | 22-21 | 22-32 |
|--------------------|-------|-------|-------|-------|
| Service Rating     | I     | I     | II    | I     |
| Number of Contacts | 12    | 19    | 21    | 32    |
| Contact Size       | 12    | 12    | 16    | 20    |

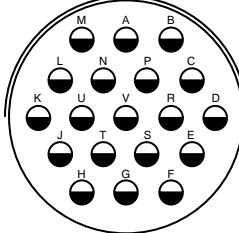
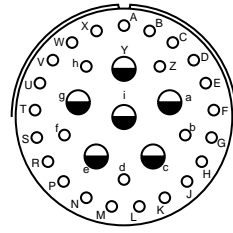
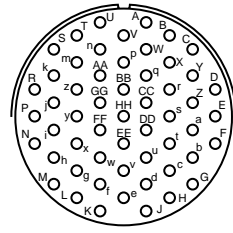
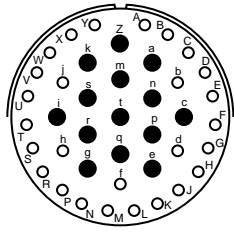

| Insert Arrangement | 22-41    | 22-55 | 22-95    | 24-19 |
|--------------------|----------|-------|----------|-------|
| Service Rating     | I        | I     | I        | II    |
| Number of Contacts | 27    14 | 55    | 26    6  | 19    |
| Contact Size       | 20    16 | 20    | 20    12 | 12    |

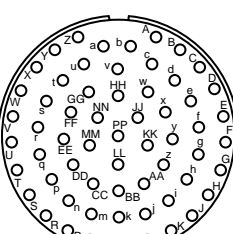
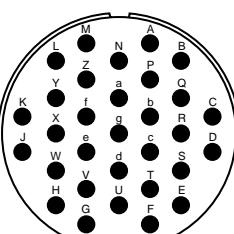

| Insert Arrangement | 24-31 | 24-61 |
|--------------------|-------|-------|
| Service Rating     | I     | I     |
| Number of Contacts | 31    | 61    |
| Contact Size       | 16    | 20    |

NOTE: Connectors sold as mil-spec connectors will have mil-spec markings on the insert (a "snail-trail" designating the numerical path). Commercial versions will have insert markings as shown here.

**CONTACT LEGEND**

○ 20    ● 16    ◐ 12

38999  
SJT

26482  
Matrix 2

83723 III  
Pyle

5015  
Crimp Rear  
Release Matrix

26500 Pyle

Printed  
Circuit Board

EMI Filter  
Transient

Fiber Optics

High Speed  
Contacts

Options  
Others

38999  
SJT I II III

26482  
Matrix 2

83723 III  
Matrix Pyle

5015  
Crimp Rear  
Release Matrix

26500 Pyle

Printed  
Circuit Board

EMI Filter  
Transient

Fiber Optics

High Speed  
Contacts

Options  
Others

**CLASS DESCRIPTIONS**

| Military MIL-DTL-26482, Series 2 | Amphenol/Matrix Commercial MB1 Series | Description   |
|----------------------------------|---------------------------------------|---|
| Class L                          | Class R                               | Aluminum shell, electroless nickel finish, fluid resistant            |
| Class E                          | –                                     | Inactive, superceded by Class L*                                      |
| Class R                          | –                                     | Inactive, superceded by Class L*                                      |
| Class A                          | Class A                               | Aluminum shell, black non-conductive anodized finish, fluid resistant |
| –                                | Class G                               | Stainless steel shell, passivated, fluid resistant                    |
| Class W                          | Class W                               | Aluminum shell, olive drab cadmium plated, corrosion/fluid resistant  |

\* Ref. MIL-DTL-26482

**PERFORMANCE SPECIFICATIONS**

**SERVICE RATINGS\*\***

| Service Rating | Recommended Operating AC Voltage at Sea Level | Test Voltage AC (RMS), 60 cps |            |            |             |
|----------------|---|-------------------------------|------------|------------|-------------|
|                |   | Sea Level                     | 50,000 ft. | 70,000 ft. | 110,000 ft. |
| I              | 600   | 1,500                         | 500        | 375        | 200         |
| II             | 1,000   | 2,300                         | 750        | 500        | 200         |

\*\* Service Rating is comparable to MS rating A. Miniature connectors rated Service Rating I will provide a minimum flashover voltage at sea level of 2,000 volts AC (RMS). Service Rating II is comparable to MS Service Rating D, and will provide a minimum flashover voltage of 2,800 volts AC (RMS) at sea level.

Please note that the electrical data given is not an establishment of electrical safety factors. This is left entirely in the designer's hands, as he can best determine which peak voltage, switching surges, transients, etc. can be expected in a particular circuit.

**OPERATING TEMPERATURE RANGE**

–65°C (–85°F) to 200°C (392°F)

**ENVIRONMENTAL SEAL**

Wired, mated connectors with the specified accessory attached will meet the altitude immersion test specified in MIL-DTL-26482.

**DURABILITY**

Minimum of 500 mating cycles.

**SHOCK AND VIBRATION REQUIREMENTS**

When tested as follows, the connector shall sustain no physical damage, or electrical discontinuity exceeding one microsecond.

**SHOCK:**

Pulse of an approximate half sine wave of 300g magnitude with duration of 3 milliseconds applied in three axes.

**VIBRATION:**

Sixteen hours of random vibration having a range of 50 to 2,000 Hz with a 41.7G peak level.

1. 2. 3. 4. 5. 6. 7.

| MIL-DTL-26482, Series 2 | Connector Type | Connector Style | Service Class | Shell Size/Insert Arrangement | Contact Type | Alternate Rotation of Insert | Modification Number |
|-------------------------|----------------|-----------------|---------------|-------------------------------|--------------|------------------------------|---------------------|
| MILITARY                | MS             | 3470            | W             | 12-10                         | P            | W                            | NA                  |
| COMMERCIAL              | MB1            | 0               | W             | 12-10                         | P            | W                            | (xxx)               |

### Step 1. Military Connector Type

|           |                              |
|-----------|------------------------------|
| <b>MS</b> | Designates Military Standard |
|-----------|------------------------------|

### Step 2. Select a Connector Style

|             | Designates                               |
|-------------|--|
| <b>3470</b> | Wall Mount Receptacle with Narrow Flange |
| <b>3472</b> | Wall Mount Receptacle with Wide Flange   |
| <b>3471</b> | Cable Connecting Receptacle              |
| <b>3474</b> | Jam Nut Receptacle                       |
| <b>3476</b> | Straight Plug                            |
| <b>3475</b> | Straight Plug with RFI Grounding Fingers |

### Step 3. Select a Service Class

|          | Designates   |
|----------|--|
| <b>L</b> | Aluminum shell, electroless nickel finish, fluid resistant insert            |
| <b>A</b> | Aluminum shell, black anodized finish, non-conductive fluid resistant insert |
| <b>W</b> | Aluminum shell, olive drab cadmium plated, fluid resistant insert            |

Note: For stainless steel shell, passivated, order by Amphenol®/Matrix® commercial Class G.  
Class L inactivates classes E and R (Ref. MIL-DTL-26482)

### Step 4. Select a Shell Size & Insert

Arrangement from chart on page 111.

Shell Size & Insert Arrangements are on pages 111  
First number represents Shell Size, second number is the Insert Arrangement.

### Step 5. Select a Contact Type

|          | Designates      |
|----------|-----------------|
| <b>P</b> | Pin Contacts    |
| <b>S</b> | Socket Contacts |
| <b>A</b> | Less Pins       |
| <b>B</b> | Less Sockets    |

Use A & B only when other than a full complement of power contacts is to be installed.

### Step 6. Select an Alternate Rotation of Insert

“W”, “X”, “Y”, “Z” designate that insert is rotated in its shell from normal position. No letter required for normal (no rotation) position. See page 111 for description of alternate positions.

For ordering information on accessories, such as protection caps and backshell hardware, contact Amphenol Aerospace, Sidney, NY.

### Step 1. Commercial Connector Type

|            |   |
|------------|---|
| <b>MB1</b> | Designates Amphenol®/Matrix® Bayonet Coupling Connector |
|------------|---|

### Step 2. Select a Connector Style

|          | Designates                               |
|----------|--|
| <b>0</b> | Wall Mount Receptacle with Narrow Flange |
| <b>1</b> | Wall Mount Receptacle with Wide Flange   |
| <b>3</b> | Cable Connecting Receptacle              |
| <b>4</b> | Jam Nut Receptacle                       |
| <b>6</b> | Straight Plug                            |
| <b>8</b> | Straight Plug with RFI Grounding Fingers |

### Step 3. Select a Service Class

|          | Designates  |
|----------|---|
| <b>A</b> | Aluminum shell, black anodized finish, non-conductive, fluid resistant insert |
| <b>R</b> | Aluminum shell, electroless nickel finish, fluid resistant insert             |
| <b>G</b> | Stainless steel shell, passivated, fluid resistant insert                     |
| <b>W</b> | Aluminum shell, cadmium plated, olive drab finish, fluid resistant insert     |

### Step 4. Select a Shell Size & Insert

Arrangement from chart on page 111.

Shell Size & Insert Arrangements are on pages 111.  
First number represents Shell Size, second number is the Insert Arrangement.

### Step 5. Select a Contact Type

|          | Designates      |
|----------|-----------------|
| <b>P</b> | Pin Contacts    |
| <b>S</b> | Socket Contacts |

### Step 6. Select an Alternate Rotation of Insert

“W”, “X”, “Y”, “Z” designate that insert is rotated in its shell from normal position. No letter required for normal (no rotation) position. See page 111 for description of alternate positions.

### Step 7. Modification Number

Consult Amphenol Aerospace, Sidney, NY for information.  
For strain reliefs use the following codes:  
(189) E-nut M85049/31 configuration  
(190) Straight strain relief M85049/52 configuration  
(191) 90° strain relief M85049/51 configuration

38999  
III  
II  
I  
SJT

26482  
Matrix 2

83723 III  
Matrix  
Pyle

5015  
Crimp Rear  
Release Matrix

26500 Pyle

Printed  
Circuit Board

EMI Filter  
Transient

Fiber Optics

High Speed  
Contacts

Options  
Others

38999  
SJT I II III

26482  
Matrix 2

83723 III  
Matrix Pyle

5015  
Crimp Rear  
Release Matrix

26500 Pyle

Printed  
Circuit Board

EMI Filter  
Transient

Fiber Optics

High Speed  
Contacts

Options  
Others

**PART #**

\*To complete, see how to order page 115.

|                   | Connector Type | Shell Style | Service Class | Shell Size & Insert Arrg | Contact Type | Alternate Rotation of Insert | Modification Number |
|-------------------|----------------|-------------|---------------|--------------------------|--------------|------------------------------|---------------------|
| <b>Military</b>   | <b>MS</b>      | <b>3470</b> | X             | X-X                      | X            | X                            | NA                  |
| <b>Commercial</b> | <b>MB1</b>     | <b>0</b>    | X             | X-X                      | X            | X                            | (XXX)               |

**MS3470  
MB10**

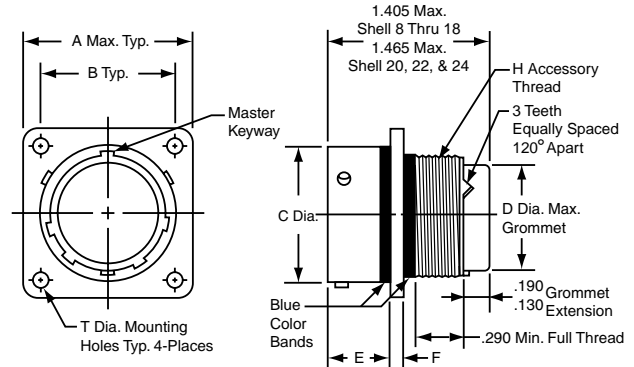

| Shell Size | A Max. | B ±.005 | C Dia. ±.003 | D Dia. Max. | E         | F ±.016 | H Accessory Thread Class 2A | T Dia. ±.005 |
|------------|--------|---------|--------------|-------------|-----------|---------|-----------------------------|--------------|
| 8          | .828   | .594    | .471         | .305        | .462/.431 | .062    | .5000-20 UNF                | .120         |
| 10         | .954   | .719    | .588         | .405        | .462/.431 | .062    | .6250-24 UNEF               | .120         |
| 12         | 1.047  | .812    | .748         | .531        | .462/.431 | .062    | .7500-20 UNEF               | .120         |
| 14         | 1.141  | .906    | .873         | .665        | .462/.431 | .062    | .8750-20 UNEF               | .120         |
| 16         | 1.234  | .969    | .998         | .790        | .462/.431 | .062    | 1.0000-20 UNEF              | .120         |
| 18         | 1.328  | 1.062   | 1.123        | .869        | .462/.431 | .062    | 1.0625-18 UNEF              | .120         |
| 20         | 1.453  | 1.156   | 1.248        | .994        | .587/.556 | .094    | 1.1875-18 UNEF              | .120         |
| 22         | 1.578  | 1.250   | 1.373        | 1.119       | .587/.556 | .094    | 1.3125-18 UNEF              | .120         |
| 24         | 1.703  | 1.375   | 1.498        | 1.244       | .620/.589 | .094    | 1.4375-18 UNEF              | .147         |

All dimensions for reference only.

**MS3472 (MB11) – MIL-DTL-26482, Series 2**  
Wall Mounting Receptacle (with Wide Flange)

**PART #**

\*To complete, see how to order page 115.

|                   | Connector Type | Shell Style | Service Class | Shell Size & Insert Arrg | Contact Type | Alternate Rotation of Insert | Modification Number |
|-------------------|----------------|-------------|---------------|--------------------------|--------------|------------------------------|---------------------|
| <b>Military</b>   | <b>MS</b>      | <b>3472</b> | X             | X-X                      | X            | X                            | NA                  |
| <b>Commercial</b> | <b>MB1</b>     | <b>1</b>    | X             | X-X                      | X            | X                            | (XXX)               |

**MS3472  
MB11**

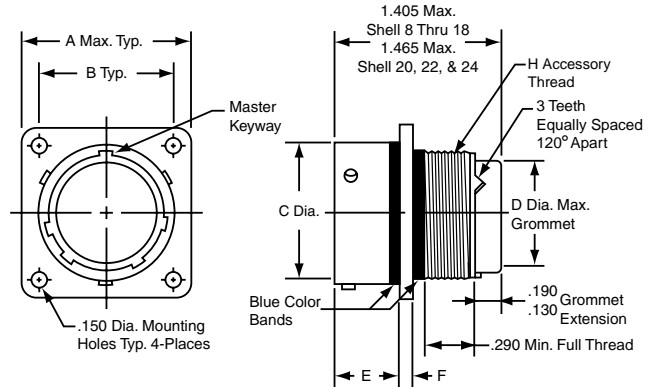

| Shell Size | A Max. | B ±.005 | C Dia. ±.003 | D Dia. Max. | E         | F ±.016 | H Accessory Thread Class 2A |
|------------|--------|---------|--------------|-------------|-----------|---------|-----------------------------|
| 8          | 1.065  | .734    | .471         | .305        | .493/.462 | .062    | .5000-20 UNF                |
| 10         | 1.141  | .812    | .588         | .405        | .493/.462 | .062    | .6250-24 UNEF               |
| 12         | 1.266  | .938    | .748         | .531        | .493/.462 | .062    | .7500-20 UNEF               |
| 14         | 1.360  | 1.031   | .873         | .665        | .493/.462 | .062    | .8750-20 UNEF               |
| 16         | 1.453  | 1.125   | .998         | .790        | .493/.462 | .062    | 1.0000-20 UNEF              |
| 18         | 1.532  | 1.203   | 1.123        | .869        | .493/.462 | .062    | 1.0625-18 UNEF              |
| 20         | 1.688  | 1.297   | 1.248        | .994        | .587/.556 | .094    | 1.1875-18 UNEF              |
| 22         | 1.766  | 1.375   | 1.373        | 1.119       | .587/.556 | .094    | 1.3125-18 UNEF              |
| 24         | 1.891  | 1.500   | 1.498        | 1.244       | .620/.589 | .094    | 1.4375-18 UNEF              |

All dimensions for reference only.



# MS3471 (MB13) – MIL-DTL-26482, Series 2 Cable Connecting Receptacle



### PART #

\*To complete, see how to order page 115.

| Connector Type    | Shell Style | Service Class | Shell Size & Insert Arrg | Contact Type | Alternate Rotation of Insert | Modification Number |
|-------------------|-------------|---------------|--------------------------|--------------|------------------------------|---------------------|
| <b>Military</b>   | <b>MS</b>   | <b>3471</b>   | X                        | X-X          | X                            | NA                  |
| <b>Commercial</b> | <b>MB1</b>  | <b>3</b>      | X                        | X-X          | X                            | (XXX)               |

**MS3471  
MB13**

| Shell Size | A Max. | B Dia. ±.020 | C Dia. ±.003 | D Dia. Max. | E         | F ±.016 | H Accessory Thread Class 2A |
|------------|--------|--------------|--------------|-------------|-----------|---------|-----------------------------|
| 8          | .828   | .938         | .471         | .305        | .462/.431 | .062    | .5000-20 UNF                |
| 10         | .954   | 1.062        | .588         | .405        | .462/.431 | .062    | .6250-24 UNEF               |
| 12         | 1.047  | 1.156        | .748         | .531        | .462/.431 | .062    | .7500-20 UNEF               |
| 14         | 1.141  | 1.250        | .873         | .665        | .462/.431 | .062    | .8750-20 UNEF               |
| 16         | 1.234  | 1.344        | .998         | .790        | .462/.431 | .062    | 1.0000-20 UNEF              |
| 18         | 1.328  | 1.438        | 1.123        | .869        | .462/.431 | .062    | 1.0625-18 UNEF              |
| 20         | 1.453  | 1.562        | 1.248        | .994        | .587/.556 | .094    | 1.1875-18 UNEF              |
| 22         | 1.578  | 1.688        | 1.373        | 1.119       | .587/.556 | .094    | 1.3125-18 UNEF              |
| 24         | 1.703  | 1.812        | 1.498        | 1.244       | .620/.589 | .094    | 1.4375-18 UNEF              |

All dimensions for reference only.

# MS3474 (MB14) – MIL-DTL-26482, Series 2 Jam Nut Receptacle



### PART #

\*To complete, see how to order page 115.

| Connector Type    | Shell Style | Service Class | Shell Size & Insert Arrg | Contact Type | Alternate Rotation of Insert | Modification Number |
|-------------------|-------------|---------------|--------------------------|--------------|------------------------------|---------------------|
| <b>Military</b>   | <b>MS</b>   | <b>3474</b>   | X                        | X-X          | X                            | NA                  |
| <b>Commercial</b> | <b>MB1</b>  | <b>4</b>      | X                        | X-X          | X                            | (XXX)               |

**MS3474  
MB14**

| Shell Size | A Max. | B ±.005 | C Dia. ±.003 | D Dia. Max. | E         | F         | H Accessory Thread Class 2A | J Mounting Thread Class 2A | K Max. |
|------------|--------|---------|--------------|-------------|-----------|-----------|-----------------------------|----------------------------|--------|
| 8          | .954   | .525    | .471         | .305        | .707/.658 | .113/.086 | .5000-20 UNF                | .5625-24 UNEF              | .767   |
| 10         | 1.078  | .650    | .588         | .405        | .707/.658 | .113/.086 | .6250-24 UNF                | .6875-24 UNEF              | .892   |
| 12         | 1.266  | .813    | .748         | .531        | .707/.658 | .113/.086 | .7500-20 UNEF               | .8750-20 UNEF              | 1.079  |
| 14         | 1.391  | .937    | .873         | .665        | .707/.658 | .113/.086 | .8750-20 UNEF               | 1.0000-20 UNEF             | 1.205  |
| 16         | 1.516  | 1.061   | .998         | .790        | .707/.658 | .113/.086 | 1.0000-20 UNEF              | 1.1250-18 UNEF             | 1.329  |
| 18         | 1.641  | 1.186   | 1.123        | .869        | .707/.658 | .113/.086 | 1.0625-18 UNEF              | 1.2500-18 UNEF             | 1.455  |
| 20         | 1.828  | 1.311   | 1.248        | .994        | .772/.721 | .148/.096 | 1.1875-18 UNEF              | 1.3750-18 UNEF             | 1.579  |
| 22         | 1.954  | 1.436   | 1.373        | 1.119       | .772/.721 | .148/.096 | 1.3125-18 UNEF              | 1.5000-18 UNEF             | 1.705  |
| 24         | 2.078  | 1.561   | 1.498        | 1.244       | .772/.721 | .148/.096 | 1.4375-18 UNEF              | 1.6250-18 UNEF             | 1.829  |

All dimensions for reference only.

38999  
SJT

26482  
Matrix 2

83723 III  
Pyle

5015  
Crimp Rear Release Matrix

26500 Pyle

Printed  
Circuit Board

EMI Filter  
Transient

Fiber Optics

High Speed  
Contacts

Options  
Others

38999  
SJT I II III

26482  
Matrix 2

83723 III  
Matrix Pyle

5015  
Crimp Rear  
Release Matrix

26500 Pyle

Printed  
Circuit Board

EMI Filter  
Transient

Fiber Optics

High Speed  
Contacts

Options  
Others

**PART #**

\*To complete, see how to order page 115.

|                   | Connector Type | Shell Style | Service Class | Shell Size & Insert Arrg | Contact Type | Alternate Rotation of Insert | Modification Number |
|-------------------|----------------|-------------|---------------|--------------------------|--------------|------------------------------|---------------------|
| <b>Military</b>   | <b>MS</b>      | <b>3476</b> | X             | X-X                      | X            | X                            | NA                  |
| <b>Commercial</b> | <b>MB1</b>     | <b>6</b>    | X             | X-X                      | X            | X                            | (XXX)               |

**MS3476  
MB16**



| Shell Size | A Dia. Max. | B Dia. Max. | H Accessory Thread Class 2A |
|------------|-------------|-------------|-----------------------------|
| 8          | .782        | .305        | .5000-20 UNF                |
| 10         | .926        | .405        | .6250-24 UNEF               |
| 12         | 1.043       | .531        | .7500-20 UNEF               |
| 14         | 1.183       | .665        | .8750-20 UNEF               |
| 16         | 1.305       | .790        | 1.0000-20 UNEF              |
| 18         | 1.391       | .869        | 1.0625-18 UNEF              |
| 20         | 1.531       | .994        | 1.1875-18 UNEF              |
| 22         | 1.656       | 1.119       | 1.3125-18 UNEF              |
| 24         | 1.777       | 1.244       | 1.4375-18 UNEF              |

All dimensions for reference only.

**MS3475 (MB18) – MIL-DTL-26482, Series 2**  
Straight Plug (With RFI Grounding Fingers)

**PART #**

\*To complete, see how to order page 115.

|                   | Connector Type | Shell Style | Service Class | Shell Size & Insert Arrg | Contact Type | Alternate Rotation of Insert | Modification Number |
|-------------------|----------------|-------------|---------------|--------------------------|--------------|------------------------------|---------------------|
| <b>Military</b>   | <b>MS</b>      | <b>3475</b> | X             | X-X                      | X            | X                            | NA                  |
| <b>Commercial</b> | <b>MB1</b>     | <b>8</b>    | X             | X-X                      | X            | X                            | (XXX)               |

**MS3475  
MB18**

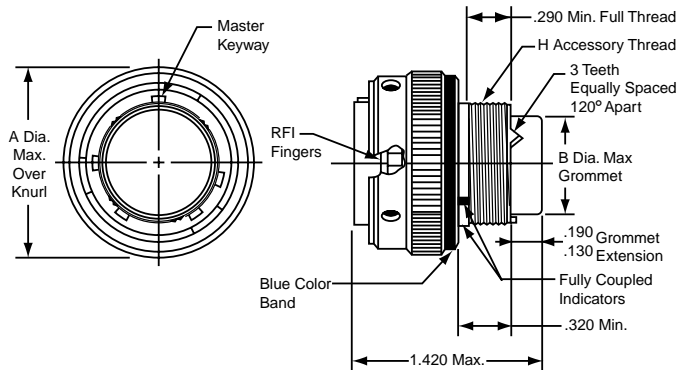

| Shell Size | A Dia. Max. | B Dia. Max. | H Accessory Thread Class 2A |
|------------|-------------|-------------|-----------------------------|
| 8          | .782        | .305        | .5000-20 UNF                |
| 10         | .926        | .405        | .6250-24 UNEF               |
| 12         | 1.043       | .531        | .7500-20 UNEF               |
| 14         | 1.183       | .665        | .8750-20 UNEF               |
| 16         | 1.305       | .790        | 1.0000-20 UNEF              |
| 18         | 1.391       | .869        | 1.0625-18 UNEF              |
| 20         | 1.531       | .994        | 1.1875-18 UNEF              |
| 22         | 1.656       | 1.119       | 1.3125-18 UNEF              |
| 24         | 1.777       | 1.244       | 1.4375-18 UNEF              |

All dimensions for reference only.

### MIL-DTL-26482, SERIES 2 CRIMP CONTACTS

| Contact Size | Wire Range |                 | Socket Contacts      |                             | Pin Contacts         |                             |
|--------------|------------|-----------------|----------------------|-----------------------------|----------------------|-----------------------------|
|              | AWG        | mm <sup>2</sup> | Military Part Number | Amphenol/Matrix Part Number | Military Part Number | Amphenol/Matrix Part Number |
| 20           | 24-20      | 0.2-0.6         | M39029/5-115         | M5100-001-0020L             | M39029/4-110         | M5000-054-0020L             |
| 16           | 20-16      | 0.5-1.4         | M39029/5-116         | M5100-001-0016L             | M39029/4-111         | M5000-054-0016L             |
| 12           | 14-12      | 2-3             | M39029/5-118         | M5100-001-0012L             | M39029/4-113         | M5000-054-0012L             |

### CONTACT CURRENT RATING AND RETENTION

| Contact Size* | DC Test Amperage | Contact Retention |       |
|---------------|------------------|-------------------|-------|
|               |                  | Axial Load        |       |
|               |                  | lb.               | N     |
| 20            | 7.5              | 15                | 66.7  |
| 16            | 13.0             | 25                | 111.2 |
| 12            | 23.0             | 30                | 133.4 |

\* Organize individual circuits to maintain heat rise within operating temperature requirements.

### SEALING PLUGS

| Contact Size | Sealing Plugs        |                             |
|--------------|----------------------|-----------------------------|
|              | Military Part Number | Amphenol/Matrix Part Number |
| 20           | MS27488-20           | 10-405996-020               |
| 16           | MS27488-16           | 10-405996-016               |
| 12           | MS27488-12           | 10-405996-012               |

### CRIMPING TOOLS

| Contact Size | Wire Range |                 | Finished Wire Dia. Range |           | Crimping Tool Part Number  | Turret or Positioner Part Number |
|--------------|------------|-----------------|--------------------------|-----------|----------------------------|----------------------------------|
|              | AWG        | mm <sup>2</sup> | Inch                     | mm        |                            |                                  |
| 20           | 24-20      | 0.2-0.6         | .040-.083                | 1.02-2.11 | M22520/1-01 or M22520/2-01 | M22520/1-02 or M22520/2-02       |
| 16           | 20-16      | 0.5-1.4         | .053-.103                | 1.34-2.62 | M22520/1-01                | M22520/1-02                      |
| 12           | 14-12      | 2-3             | .097-.158                | 2.46-4.01 | M22520/1-01                | M22520/1-02                      |

### INSERTION/REMOVAL TOOLS

| Contact Size | Color Code   | Military Part Number | Amphenol/Matrix Part Number |
|--------------|--------------|----------------------|-----------------------------|
| 20           | Red/White    | M81969/14-11         | 10-538988-021               |
| 16           | Blue/White   | M81969/14-03         | 10-538988-016               |
| 12           | Yellow/White | M81969/14-04         | 10-538988-012               |

Note: Each connector is furnished with contacts. One spare for inserts requiring 1 to 26 of each contact, two spares for inserts with more than 26 contacts, and a minimum of one sealing plug up to 15% of the number of contacts.

38999

SJT I II III

26482  
Matrix 2

83723 III  
Matrix Pyle

5015  
Crimp Rear  
Release Matrix

26500 Pyle

Printed  
Circuit Board

EMI Filter  
Transient

Fiber Optics

High Speed  
Contacts

Options  
Others



## MIL-DTL-26482, Series 1 Connectors

There are several additional connector types within the Amphenol® MIL-DTL-26482 family. MIL-Spec and commercial versions are available with varying design characteristics and customer options to meet cost considerations and to provide users with the most design flexibility possible.

MIL-DTL-26482, Series 1 Circular connectors are shown in detail in Amphenol Industrial Operations' catalog 12-070, which can be supplied upon request or visit [www.amphenol-industrial.com](http://www.amphenol-industrial.com).

Briefly the MIL-DTL-26482 Series 1 circulars are described as follows:

### PT, SP, MS/PT Commercial/MIL-DTL-26482, Series 1

These are bayonet type with solder contacts. Both the insert and main joint gasket are molded from resilient neoprene. This provides excellent moisture sealing at the gasket and superior electrical isolation of the contact in the inserts.

Socket contacts are closed entry design. Printed circuit board contacts are also available in this series.

The SP is a modification of the PT providing special shells with a wide mounting flange for back panel mounting. The SP also has a durable non-conductive hard anodic "Alumilite" coating which provides abrasion and corrosion protection.

There are 8 shell styles in the PT, SP and MS/PT series, and shell sizes are 6-24. The PT solder is UL recognized. Hermetics are also available.

### PT-SE, SP-SE, MS/PT-SE Commercial/MIL-DTL-26482, Series 1

These are a derivative of the PT line, bayonet type. However, they incorporate crimp contacts that are rear insertable, front releasable. An MS approved spring tower retention system holds the contacts in place.

### PT-CE, SP-CE Commercial crimp type

Another derivative of the PT line, bayonet type. These also have crimp contacts that are rear insertable, front releasable, but the contacts are held in place by a nylon wafer retention system. The voidless one-piece insert and grommet assembly provide continuous dielectric separation between contacts.

### PC, PC-SE, PC-CE Commercial solder and crimp type

The PC series within the Amphenol® miniature circular family is threaded coupling, rather than bayonet coupling. The threads are double-stubbed so they can not be cross threaded.

The PC is offered with solder contacts. The PC-SE has crimp contacts in a spring tower retention system, while the PC-CE has crimp contacts in a nylon wafer retention system. Hermetics are available

All miniature circular are intermateable and intermountable with each other except for the threaded coupling PC Series.

For further information ask for catalog 12-070. Consult Amphenol Industrial Operations, Sidney, NY for any assistance on these products or for any specific application needs. See catalog 12-070 online at [www.amphenol-industrial.com](http://www.amphenol-industrial.com)

# Amphenol MIL-DTL-83723, Series III, Matrix®



## TABLE OF CONTENTS

### MIL-DTL-83723, Series III, Matrix®

- Table of Contents . . . . . 121
- Wide Variety of Coupling Styles & Options . . . . . 122
- Class Descriptions, Performance Specifications,  
Quick Reference Chart . . . . . 123
- Insert Availability and Identification,  
Alternate Keying Positions, Alternate Rotations . . . . . 124
- Insert Arrangement Drawings . . . . . 125, 126

### Bayonet Shell Styles:

- How to Order (Military & Commercial). . . . . 127
- Wall Mounting Receptacle M83723/71 & /72 (MB30),  
Jam Nut Receptacle M83723/73 & /74 (MB34) . . . . . 128
- Straight Plug M83723/75 & /76 (MB36),  
Straight Plug with RFI Grounding Fingers M83723/77 & /78 (MB38). . 129

### Threaded Shell Styles:

- How to Order (Military & Commercial). . . . . 130
- Wall Mounting Receptacle M83723/82 & /83 (MT30),  
Jam Nut Receptacle M83723/84 & /85 (MT34) . . . . . 131
- Straight Plug M83723/86 & /87 (MT36),  
Straight Plug with RFI Grounding Fingers M83723/91 & /92 (MT38) . . 132
- Straight Plug (Self-locking) M83723/95 & /96 (MT37). . . . . 133

### Quick-Disconnect Shell Styles:

- How to Order (Military & Commercial). . . . . 134
- Quick-Disconnect Plug M83723/66 & /67 (MQ36),  
Quick-Disconnect Plug with Lanyard M83723/68 & /69  
(MQ35/MQ38), Receptacle Adapter . . . . . 135

### Contact Information, Sealing Plugs:

- Crimp and Insertion/Removal Tools. . . . . 136



## MIL-DTL-83723 Series III, Matrix® Typical Markets:

- Military & Commercial Aviation  
- High Temperature Applications
- Military Vehicles





Amphenol Aerospace offers the Matrix® Product line of MIL-DTL-83723\*, Series III Connectors.

**MIL-DTL-83723, SERIES III CONNECTORS WITH BAYONET COUPLING**



**M83723/71 & 72 wall mounting receptacle**



**M83723/73 & 74 jam nut receptacle**



**M83723/75 & 76 straight plug**



**M83723/77 & 78 straight plug, RFI grounding**

- Quick positive coupling assured by 3 point bayonet coupling system; visual confirmation of complete coupling
- Five key/keyway design eliminates mismatching
- Shell sizes 8 – 24
- Intermateable with most MIL-DTL-26500 bayonet coupling connectors

**MIL-DTL-83723, SERIES III CONNECTORS WITH THREADED COUPLING**



**M83723/82 & 83 wall mounting receptacle**



**M83723/84 & 85 jam nut receptacle**



**M83723/86 & 87 straight plug**



**M83723/91 & 92 straight plug, RFI grounding**



**M83723/95 & 96 straight plug, self-locking**

- Threaded coupling offers greater resistance to decoupling with a visual full mating indicator band on the shell
- Shell sizes 8 – 28
- Intermateable with most MIL-DTL-26500 threaded coupling connectors

This series provides many choices within the range of a medium sized, environmentally resistant circular connector. With three coupling style choices - bayonet, threaded and quick-disconnect - the versatility of this family makes it increasingly popular for panel mount, box mount and line-to-line applications in aircraft. For general duty environmentally resistant requirements, this family of connectors provides a wide range of interconnection solutions.

**DESIGN CHARACTERISTICS**

- Recommended operating voltage to 600 VAC (RMS) at sea level
- Complete environmental sealing includes individual contact seals and a silicone elastomer interfacial seal with raised barriers around each pin, a shell-to-shell seal and an insert-to-shell seal. Sealing over a wide range of wire diameters is assured by a triple-webbed grommet design
- Captive coupling nut prevents tampering, while a reduced coupling ring ramp allows easier mating
- Incorporates crimp rear release contacts in sizes 12, 16 and 20; contact arrangements accept 2 to 61 circuits
- Contacts conform to SAE AS39029\*\* and use standard qualified rear-release type plastic tools
- Insertion and removal of contacts from the rear of the connector assures no damage to the front that might affect the sealing characteristics
- Grommets are constructed of tear-resistant elastomer and experience no degradation when exposed to a broad range of fluids
- Closed entry socket side of the insert is designed with a lead-in chamfer and a hard face that will accept a pin contact bent within pre-established limits
- MS and Commercial versions available
- Alternate positioning available
- Aluminum shells with black anodized, cadmium or electroless nickel finish options; passivated stainless steel shells are also available

\*\*SAE AS39029 supersedes MIL-DTL-39029

**MIL-DTL-83723, SERIES III CONNECTORS WITH QUICK DISCONNECT COUPLING**

**M83723/66 & 67 quick disconnect plug**

**M83723/68 & 69 quick disconnect plug with lanyard**

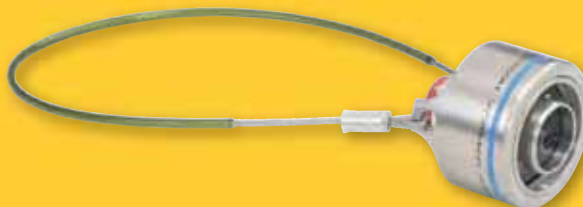

- Push-Pull, quick disconnect coupling is available in a straight plug that can be ordered with or without a lanyard release mechanism

\* MIL-DTL-83723 supersedes MIL-C-83723. Pyle-National Series of MIL-DTL-83723 is also offered by Amphenol.; see 83723 Pyle section of this catalog.

38999 III  
SJT I II III

26482 Matrix 2

83723 III Pyle  
Matrix Pyle

5015 Crimp Rear Release Matrix

26500 Pyle

Printed Circuit Board

EMI Filter Transient

Fiber Optics

High Speed Contacts

Options Others



### CLASS DESCRIPTIONS

| Military MIL-DTL-83723, Series III | Amphenol®/Matrix® Commercial MB Series | Connector Style                       | Description   |
|------------------------------------|--|---------------------------------------|---|
| Class A                            | Class A                                | Bayonet, Threaded or Quick-Disconnect | Aluminum shell, black non-conductive anodize finish, fluid resistant  |
| Class R                            | Class R                                | Bayonet, Threaded or Quick-Disconnect | Aluminum shell, electroless nickel finish, fluid resistant            |
| Class G                            | Class G                                | Bayonet, Threaded or Quick-Disconnect | Stainless steel shell, passivated, fluid resistant                    |
| Class W                            | Class W                                | Bayonet, Threaded or Quick-Disconnect | Aluminum shell, cadmium olive drab finish, corrosion/ fluid resistant |

For Classes K, S and N see the Amphenol/Pyle high temperature versions of MIL-DTL-83723, Series III in the 83723 Pyle section of this catalog.

### PERFORMANCE SPECIFICATIONS SERVICE RATINGS

| Service Rating | Recommended Operating AC Voltage at Sea Level | Test Voltage AC (RMS), 60 cps |            |            |             |
|----------------|---|-------------------------------|------------|------------|-------------|
|                |   | Sea Level                     | 50,000 ft. | 70,000 ft. | 110,000 ft. |
| I              | 600   | 1,500                         | 500        | 375        | 200         |

Please note that the electrical data given is not an establishment of electrical safety factors. This is left entirely in the designer's hands as he can best determine which peak voltage, switching surges, transients, etc. can be expected in a particular circuit.

### OPERATING TEMPERATURE RANGE

Classes A, G and R: -65°C (-85°F) to 200°C (392°F)  
Class W: -65°C to 175°C

### ENVIRONMENTAL SEAL

Wired, mated connectors with the specified accessory attached will meet the altitude immersion test specified in MIL-DTL-83723.

### DURABILITY

Minimum of 500 mating cycles.

### SHOCK AND VIBRATION REQUIREMENTS

Wired, mated connectors shall not be damaged, nor shall there be a current interruption longer than one microsecond when subjected to the following:

**SHOCK:** One shock in each of the three major axes, having a 100g peak for a six millisecond duration (half-sine pulse).

**VIBRATION:** Twelve hours of random vibration having a range of 10 to 2,000 Hz with a .06 inch double amplitude (10-55 Hz) and a 20g peak level (55-2,000 Hz).

The following is a quick reference chart for use in determining either the military designation or the commercial Amphenol®/Matrix® designation number of MIL-DTL-83723 connectors. See also the how to order pages for complete part number breakdowns.

| Connector Style                              | MIL-DTL-83723 Military Designation | Amphenol®/Matrix® Commercial Designation | Contact Type |
|--|------------------------------------|--|--------------|
| <b>BAYONET COUPLING</b>                      |                                    |  |              |
| Square flange wall mount receptacle          | M83723/71                          | MB30( )S                                 | Socket       |
| Square flange wall mount receptacle          | M83723/72                          | MB30( )P                                 | Pin          |
| Single hole mount jam nut receptacle         | M83723/73                          | MB34( )S                                 | Socket       |
| Single hole mount jam nut receptacle         | M83723/74                          | MB34( )P                                 | Pin          |
| Standard straight plug                       | M83723/75                          | MB36( )S                                 | Socket       |
| Standard straight plug                       | M83723/76                          | MB36( )P                                 | Pin          |
| Straight plug with RFI grounding fingers     | M83723/77                          | MB38( )S                                 | Socket       |
| Straight plug with RFI grounding fingers     | M83723/78                          | MB38( )P                                 | Pin          |
| <b>THREADED COUPLING</b>                     |                                    |  |              |
| Square flange wall mount receptacle          | M83723/82                          | MT30( )S                                 | Socket       |
| Square flange wall mount receptacle          | M83723/83                          | MT30( )P                                 | Pin          |
| Single hole mount jam nut receptacle         | M83723/84                          | MT34( )S                                 | Socket       |
| Single hole mount jam nut receptacle         | M83723/85                          | MT34( )P                                 | Pin          |
| Standard straight plug                       | M83723/86                          | MT36( )S                                 | Socket       |
| Standard straight plug                       | M83723/87                          | MT36( )P                                 | Pin          |
| Straight plug with RFI grounding fingers     | M83723/91                          | MT38( )S                                 | Socket       |
| Straight plug with RFI grounding fingers     | M83723/92                          | MT38( )P                                 | Pin          |
| Straight plug with self-locking clutch plate | M83723/95                          | MT37( )S                                 | Socket       |
| Straight plug with self-locking clutch plate | M83723/96                          | MT37( )P                                 | Pin          |
| <b>QUICK-DISCONNECT PUSH-PULL COUPLING</b>   |                                    |  |              |
| Straight plug without lanyard                | M83723/66                          | MQ36( )P                                 | Pin          |
| Straight plug without lanyard                | M83723/67                          | MQ36( )S                                 | Socket       |
| Straight plug with lanyard                   | M83723/68                          | MQ35( )P                                 | Pin          |
| Straight plug with lanyard                   | M83723/69                          | MQ35( )S                                 | Socket       |

III  
II  
I  
SJT  
38999

Matrix 2  
26482

Matrix Pyle  
83723 III

Crimp Rear Release Matrix  
5015

Pyle  
26500

Circuit Board  
Printed

Transient  
EMI Filter

Fiber Optics

High Speed  
Contacts

Options  
Others

#### INSERT ARRANGEMENTS

| Shell Size/<br>Insert<br>Arrangement | Service<br>Rating | Total<br>Contacts | Contact Size |    |    |
|--------------------------------------|-------------------|-------------------|--------------|----|----|
|                                      |                   |                   | 12           | 16 | 20 |
| 0803                                 | I                 | 3                 |              |    | 3  |
| 0898                                 | I                 | 3                 |              |    | 3  |
| 1002                                 | I                 | 2                 |              |    | 2  |
| 1005                                 | I                 | 5                 |              |    | 5  |
| 1006                                 | I                 | 6                 |              |    | 6  |
| 1020                                 | I                 | 2                 |              | 2  |    |
| 1203                                 | I                 | 3                 |              | 3  |    |
| 1212                                 | I                 | 12                |              |    | 12 |
| 1404                                 | I                 | 4                 | 4            |    |    |
| 1407                                 | I                 | 7                 |              | 7  |    |
| 1412                                 | I                 | 12                |              | 3  | 9  |
| 1415                                 | I                 | 15                |              |    | 15 |
| 1610                                 | I                 | 10                |              | 10 |    |
| 1624                                 | I                 | 24                |              |    | 24 |
| 1808                                 | I                 | 8                 | 8            |    |    |
| 1814                                 | I                 | 14                |              | 14 |    |
| 1831                                 | I                 | 31                |              |    | 31 |
| 2016                                 | I                 | 16                |              | 16 |    |
| 2025                                 | I                 | 25                | 6            |    | 19 |
| 2028                                 | I                 | 28                | 4            |    | 24 |
| 2039                                 | I                 | 39                |              | 2  | 37 |
| 2041                                 | I                 | 41                |              |    | 41 |
| 2212                                 | I                 | 12                | 12           |    |    |
| 2219                                 | I                 | 19                |              | 19 |    |
| 2232                                 | I                 | 32                | 6            |    | 26 |
| 2239*                                | I                 | 39                |              | 12 | 27 |
| 2255                                 | I                 | 55                |              |    | 55 |
| 2429†                                |                   | 29                |              | 29 |    |
| 2430†                                |                   | 30                |              | 30 |    |
| 2443                                 | I                 | 43                |              | 20 | 23 |
| 2457                                 | I                 | 57                | 2            |    | 55 |
| 2461                                 | I                 | 61                |              |    | 61 |
| 2841†                                |                   | 41                |              | 41 |    |
| 2842†                                |                   | 42                |              | 42 |    |

† Not an MS layout.  
Connectors with these insert arrangements should be ordered by commercial part number only.

Shell size 28 is available in threaded coupling connectors only.

\* Consult Amphenol Aerospace for availability of arrangement 22-39.

See how to order for bayonet type connectors on page 127, how to order for threaded on page 130, and how to order for quick-disconnect type connectors on page 134.

Insert arrangements are per MIL-STD-1554.

#### ALTERNATE KEYING POSITIONS (Rotation of key/keyway of shell)

To avoid cross-plugging problems in applications requiring the use of more than one connector of the same size and arrangement, alternate keying positions are available as indicated in the chart below. The diagram shows the engaging view of a receptacle shell with keyways. Plug shells would be the opposite of this diagram.

In the "alternate keying positions" (positions 6, 7, 8, 9 and Y), the minor keys/keyways are positioned with reference to master key/keyway as indicated in the keying position table.



Shown is Engaging Face View of Receptacle Shell with Keyways (Plug Shell Keys would be Opposite)

#### ALTERNATE KEYING POSITIONS OF SHELL

| Shell Size                        | Polarizing Position | Key/Keyway Positions |     |     |     |
|-----------------------------------|---------------------|----------------------|-----|-----|-----|
|                                   |                     | A°                   | B°  | C°  | D°  |
| 8 thru 24                         | N                   | 105                  | 140 | 215 | 265 |
| 8 & 10                            | 6                   | 102                  | 132 | 248 | 320 |
|                                   | 7                   | 80                   | 118 | 230 | 312 |
|                                   | 8                   | 35                   | 140 | 205 | 275 |
|                                   | 9                   | 64                   | 155 | 234 | 304 |
| 10 only                           | Y*                  | 25                   | 115 | 220 | 270 |
| 12, 14, 16, 18, 20, 22, 24 and 28 | 6                   | 18                   | 149 | 192 | 259 |
|                                   | 7                   | 92                   | 152 | 222 | 342 |
|                                   | 8                   | 84                   | 152 | 204 | 334 |
|                                   | 9                   | 24                   | 135 | 199 | 240 |
|                                   | Y*                  | 98                   | 152 | 268 | 338 |

\* Position Y supersedes inactive positions 10 and Z designations. Ref. MIL-STD-1554.

#### ALTERNATE ROTATIONS (Rotation of insert)

Alternate positioning is also available with the rotation of the insert. The diagram shows the pin insert mating face. The center-line of the shell in the normal insert position (position N) coincides with the center-line of the master key/keyway in the shell. In alternate rotations, (positions 1, 2, 3, 4 and 5), the insert rotates relative to the center-line of the key/keyway of the shell. See E° call out on diagram and the table. The socket insert is rotated clockwise, and the pin insert is rotated counter-clockwise.

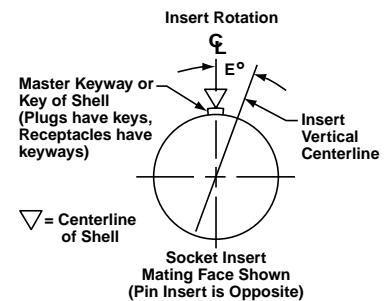

#### ALTERNATE ROTATIONS OF INSERT

| Shell Size                        | Polarizing Position | Insert Position E° |
|-----------------------------------|---------------------|--------------------|
| 8 & 10                            | N                   | 0                  |
|                                   | 1                   | 10                 |
|                                   | 2                   | 20                 |
|                                   | 3                   | 30                 |
|                                   | 4                   | 40                 |
| 12, 14, 16, 18, 20, 22, 24 and 28 | 5                   | 50                 |
|                                   | N                   | 0                  |
|                                   | 1                   | 10                 |
|                                   | 2                   | 20                 |
|                                   | 3                   | 30                 |
|                                   | 4                   | 40                 |
|                                   | 5                   | 50                 |

Note: Positions 1-5 are inactive for new designs per MIL-STD-1554.

Front Face of Pin Insert or Rear Face of Socket Insert Illustrated

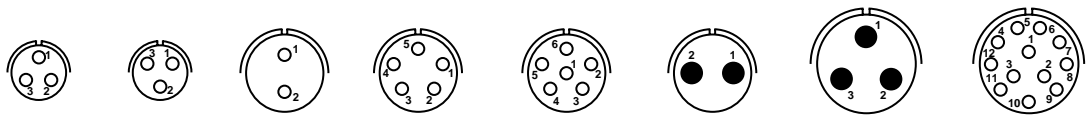

| Insert Arrangement | 0803 | 0898 | 1002 | 1005 | 1006 | 1020 | 1203 | 1212 |
|--------------------|------|------|------|------|------|------|------|------|
| Service Rating     | I    | I    | I    | I    | I    | I    | I    | I    |
| Number of Contacts | 3    | 3    | 2    | 5    | 6    | 2    | 3    | 12   |
| Contact Size       | 20   | 20   | 20   | 20   | 20   | 16   | 16   | 20   |

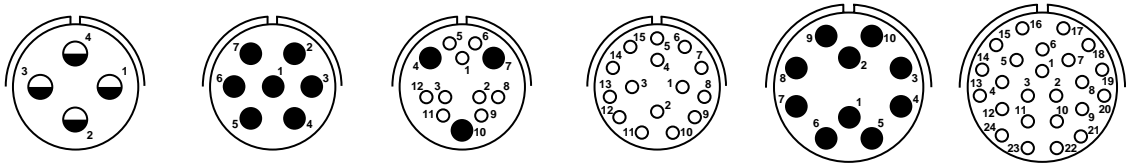

| Insert Arrangement | 1404 | 1407 | 1412 | 1415 | 1610 | 1624 |    |
|--------------------|------|------|------|------|------|------|----|
| Service Rating     | I    | I    | I    | I    | I    | I    |    |
| Number of Contacts | 4    | 7    | 9    | 3    | 15   | 10   | 24 |
| Contact Size       | 12   | 16   | 20   | 16   | 20   | 16   | 20 |

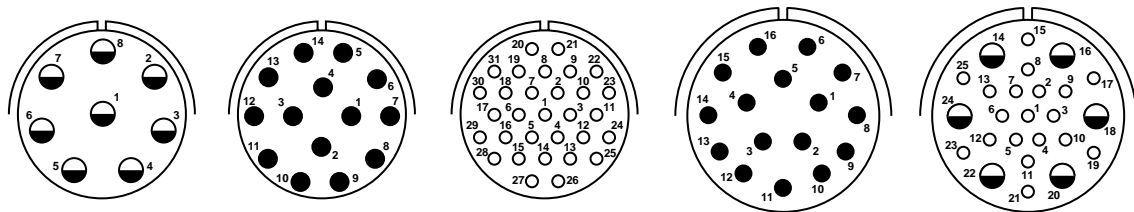

| Insert Arrangement | 1808 | 1814 | 1831 | 2016 | 2025 |    |
|--------------------|------|------|------|------|------|----|
| Service Rating     | I    | I    | I    | I    | I    |    |
| Number of Contacts | 8    | 14   | 31   | 16   | 19   | 6  |
| Contact Size       | 12   | 16   | 20   | 16   | 20   | 12 |

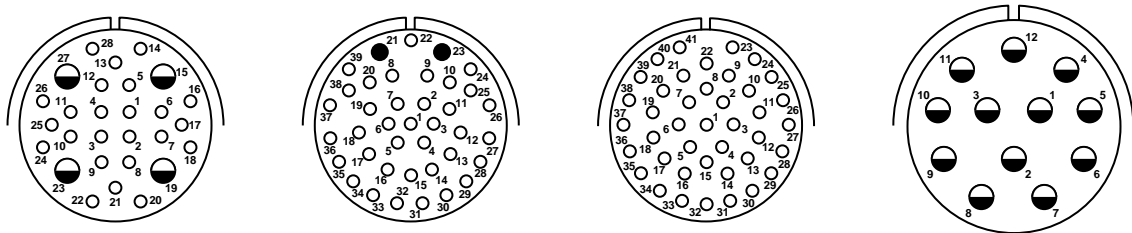

| Insert Arrangement | 2028 |    | 2039 |    | 2041 | 2212 |
|--------------------|------|----|------|----|------|------|
| Service Rating     | I    |    | I    |    | I    | I    |
| Number of Contacts | 24   | 4  | 37   | 2  | 41   | 12   |
| Contact Size       | 20   | 12 | 20   | 16 | 20   | 12   |

NOTE: Connectors sold as mil-spec connectors will have mil-spec markings on the insert (a "snail-trail" designating the numerical path). Commercial versions will have insert markings as shown here.



III  
 II  
 I  
 SJT  
**38999**

Matrix 2  
**26482**

Matrix Pyle  
**83723 III**

Crimp Rear  
 Release Matrix  
**5015**

Pyle  
**26500**

Circuit Board  
**Printed**

Transient  
**EMI Filter**

Fiber Optics

High Speed  
 Contacts

Options  
 Others

### Front Face of Pin Insert or Rear Face of Socket Insert Illustrated

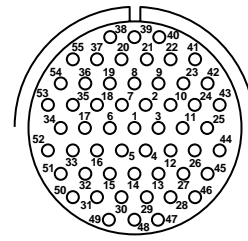
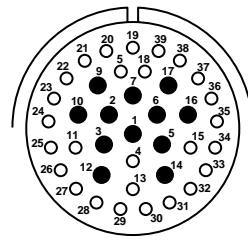
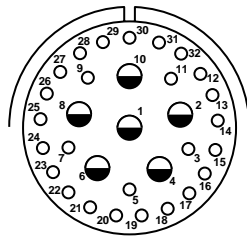
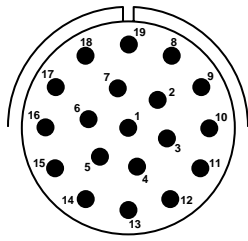

| Insert Arrangement | 2219 | 2232  | 2239* | 2255 |
|--------------------|------|-------|-------|------|
| Service Rating     | I    | I     | I     | I    |
| Number of Contacts | 19   | 26 6  | 27 12 | 55   |
| Contact Size       | 16   | 20 12 | 20 16 | 20   |

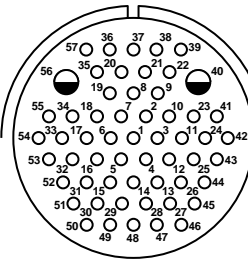
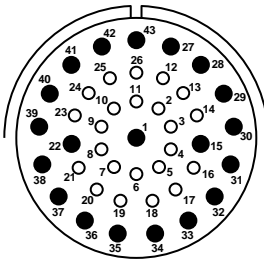
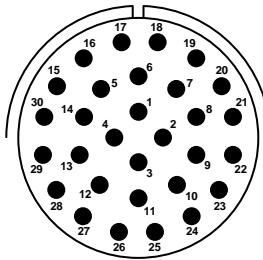
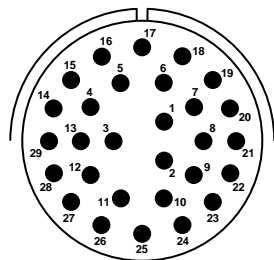

| Insert Arrangement | 2429† | 2430† | 2443  | 2457  |
|--------------------|-------|-------|-------|-------|
| Service Rating     |       |       | I     | I     |
| Number of Contacts | 29    | 30    | 23 20 | 55 2  |
| Contact Size       | 16    | 16    | 20 16 | 20 12 |

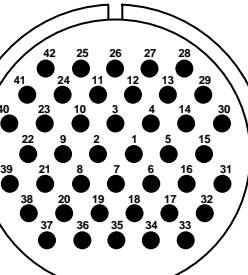
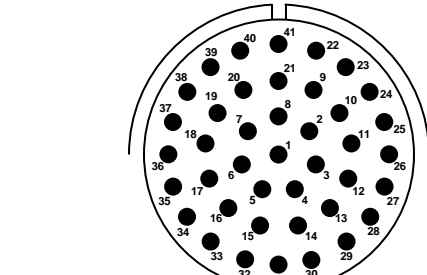
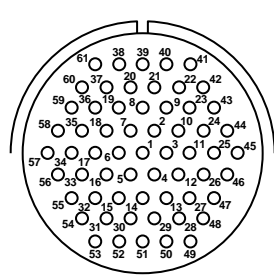

| Insert Arrangement | 2461 | 2841† | 2842† |
|--------------------|------|-------|-------|
| Service Rating     | I    |       |       |
| Number of Contacts | 61   | 41    | 42    |
| Contact Size       | 20   | 16    | 16    |

†Not a MS layout.  
Connectors with these insert arrangements can be ordered by commercial part number only.

Shell size 28 is available in threaded coupling connectors only.

\* Consult Amphenol Aerospace for availability of arrangement 22-39.

See how to order for bayonet type connectors on page 127, how to order for threaded on page 130, and how to order for quick-disconnect type connectors on page 134.

NOTE: Connectors sold as mil-spec connectors will have mil-spec markings on the insert (a "snail-trail" designating the numerical path).

Commercial versions will have insert markings as shown here.

| CONTACT LEGEND | ○  | ●  | ◐  |
|----------------|----|----|----|
|                | 20 | 16 | 12 |

38999  
SJT I II III

26482  
Matrix 2

83723 III  
Matrix Pyle

5015  
Crimp Rear Release Matrix

26500 Pyle

Printed  
Circuit Board

EMI Filter  
Transient

Fiber Optics

High Speed  
Contacts

Options  
Others

|  | 1.             | 2.   | 3.            | 4.                             | 5.   |
|--|----------------|--|---------------|--------------------------------|--|
| MIL-DTL-83723, Series III<br><b>MILITARY</b> | Connector Type | Connector Style (Bayonet) and Contact Type | Service Class | Shell Size/ Insert Arrangement | Alternate Keying Position of Shell or Alternate Rotation of Insert |
|  | M83723         | /74  | R             | 1203                           | 7  |

|  | 1.                       | 2.              | 3.            | 4.                             | 5.           | 6.   | 7.                  |
|--|--------------------------|-----------------|---------------|--------------------------------|--------------|--|---------------------|
| Amphenol® Matrix® MIL-DTL-83723, Series III<br><b>COMMERCIAL</b> | Connector Type (Bayonet) | Connector Style | Service Class | Shell Size/ Insert Arrangement | Contact Type | Alternate Keying Position of Shell or Alternate Rotation of Insert | Modification Number |
|  | MB                       | 34              | R             | 1203                           | P            | 7  | XXX                 |

### Step 1. Military Connector Type

|        |  |
|--------|--|
| M83723 | Designates MIL-DTL-83723 Series III Connectors |
|--------|--|

### Step 1. Commercial Connector Type

|    |  |
|----|--|
| MB | Designates Amphenol®/Matrix® Bayonet Coupling Connectors |
|----|--|

### Step 2. Select a Connector Style

(Refer to military specification slash sheet number.) Bayonet coupling connectors are designated by numbers /71 -/78 as follows:

|     | Designates  |
|-----|---|
| /71 | Wall Mount Receptacle with Socket Contacts        |
| /72 | Wall Mount Receptacle with Pin Contacts           |
| /73 | Jam Nut Receptacle with Socket Contacts           |
| /74 | Jam Nut Receptacle with Pin Contacts              |
| /75 | Standard Straight Plug with Socket Contacts       |
| /76 | Standard Straight Plug with Pin Contacts          |
| /77 | Straight Plug with RFI grounding, Socket Contacts |
| /78 | Straight Plug with RFI grounding, Pin Contacts    |

### Step 2. Select a Connector Style

|    | Designates                               |
|----|--|
| 30 | Wall Mount Receptacle                    |
| 34 | Jam Mount Receptacle                     |
| 36 | Standard Straight Plug                   |
| 38 | Straight Plug with RFI grounding fingers |

### Step 3. Select a Service Class

|   | Designates  |
|---|---|
| A | Aluminum shell, black non-conductive anodize finish, fluid resistant insert |
| R | Aluminum shell, electroless nickel finish, fluid resistant insert           |
| G | Stainless steel shell, passivated, fluid resistant insert                   |
| W | Aluminum shell, olive drab cadmium plated, fluid resistant insert           |

### Step 3. Select a Service Class

|   | Designates   |
|---|--|
| A | Aluminum shell, black non-conductive anodize finish, fluid resistant insert            |
| R | Aluminum shell, electroless nickel finish, fluid resistant insert                      |
| G | Stainless steel shell, passivated, fluid resistant insert                              |
| W | Aluminum shell, cadmium olive drab finish, corrosion resistant, fluid resistant insert |

Note: Consult Amphenol Aerospace for hermetic classes H and Y availability.

Note: Consult Amphenol Aerospace for hermetic classes H and Y availability.

### Step 4. Select a Shell Size & Insert Arrangement from chart on pg. 124.

Shell Size & Insert Arrangements are on page 124. First number represents Shell Size, second number is the Insert Arrangement.

### Step 4. Select a Shell Size & Insert

Arrangement from chart on page 124.

Shell Size & Insert Arrangements are on page 124. First number represents Shell Size, second number is the Insert Arrangement.

### Step 5. Select an Alternate Keying Position - Rotation of master key/keyway of shell.

Use N for normal. Use 6, 7, 8, 9 or Y for alternate keying positions. See page 124 for descriptions.

### Step 5. Select a Contact Type

|   | Designates      |
|---|-----------------|
| P | Pin Contacts    |
| S | Socket Contacts |

### or Step 5. Select an Alternate Rotation of Insert.

Use N for normal. Use 1, 2, 3, 4, or 5 for alternate rotation of insert. See page 124 for descriptions.

### Step 6. Select an Alternate Keying Position - Rotation of master key/keyway of shell.

Use 6, 7, 8, 9 or Y for alternate keying positions. No letter required for normal (No rotation position). See page 124 for descriptions.

### or Step 6. Select an Alternate Rotation of Insert.

Use 1, 2, 3, 4, or 5 for alternate rotation of insert. No letter required for normal (No rotation position). See page 124 for descriptions.

### Step 7. Modification Number

Consult Amphenol Aerospace, Sidney, NY for information.

For ordering information on accessories, such as protection caps and backshell hardware, contact Amphenol Aerospace, Sidney, NY.

|                           |            |
|---------------------------|------------|
| III                       | 38999      |
| II                        |            |
| I                         |            |
| SJT                       |            |
| Matrix 2                  | 26482      |
| Matrix Pyle               | 83723 III  |
| Crimp Rear Release Matrix | 5015       |
| Circuit Board             | 26500 Pyle |
| EMI Filter Transient      |            |
| Fiber Optics              |            |
| High Speed Contacts       |            |
| Options Others            |            |



38999  
SJT I II III

26482  
Matrix 2

83723 III  
Matrix Pyle

5015  
Crimp Rear  
Release Matrix

26500 Pyle

Printed  
Circuit Board

EMI Filter  
Transient

Fiber Optics

High Speed  
Contacts

Options  
Others

**PART #**

To complete, see how to order page 127.

| Connector Type | Connector Style (Bayonet) and Contact Type | Service Class | Shell Size & Insert Arrg | Alt. Keying Position or Alt. Rotation |
|----------------|--|---------------|--------------------------|---------------------------------------|
| Military       | M83723 /71 (with socket contacts)          | X             | X-X                      | X                                     |
| Military       | M83723 /72 (with pin contacts)             | X             | X-X                      | X                                     |

| Connector Type (Bayonet) | Connector Style | Service Class | Shell Size & Insert Arrg | Contact Type | Alt. Keying Position or Alt. Rotation | Modification Number |
|--------------------------|-----------------|---------------|--------------------------|--------------|---------------------------------------|---------------------|
| Commercial               | MB              | 30            | X                        | X-X          | X                                     | XXX                 |

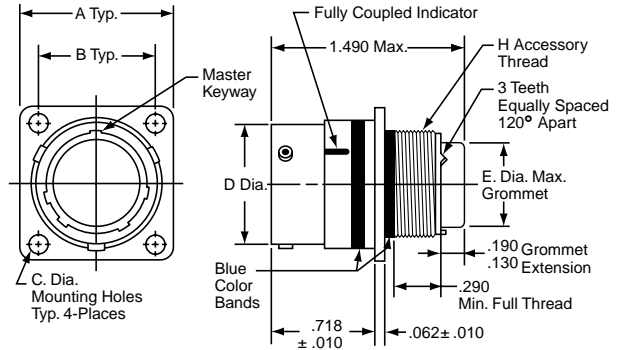

| Shell Size | A ±.005 | B ±.005 | C Dia. ±.005 | D Dia.      | E Dia. | H Accessory Thread Class 2A |
|------------|---------|---------|--------------|-------------|--------|-----------------------------|
| 8          | .812    | .594    | .120         | .536/.531   | .305   | .5000-20 UNF                |
| 10         | .937    | .719    | .120         | .659/.654   | .405   | .6250-24 UNEF               |
| 12         | 1.031   | .812    | .120         | .829/.824   | .531   | .7500-20 UNEF               |
| 14         | 1.125   | .906    | .120         | .898/.893   | .665   | .8750-20 UNEF               |
| 16         | 1.250   | .969    | .120         | 1.025/1.020 | .790   | 1.0000-20 UNEF              |
| 18         | 1.343   | 1.062   | .120         | 1.131/1.126 | .869   | 1.0625-18 UNEF              |
| 20         | 1.437   | 1.156   | .120         | 1.256/1.251 | .994   | 1.1875-18 UNEF              |
| 22         | 1.562   | 1.250   | .120         | 1.381/1.376 | 1.119  | 1.3125-18 UNEF              |
| 24         | 1.703   | 1.375   | .149         | 1.506/1.501 | 1.244  | 1.4375-18 UNEF              |

All dimensions for reference only.

**M83723/73 & /74 – MIL-DTL-83723, Series III**  
Jam Nut Receptacle with Bayonet Coupling

**PART #**

To complete, see how to order page 127.

| Connector Type | Connector Style (Bayonet) and Contact Type | Service Class | Shell Size & Insert Arrg | Alt. Keying Position or Alt. Rotation |
|----------------|--|---------------|--------------------------|---------------------------------------|
| Military       | M83723 /73 (with socket contacts)          | X             | X-X                      | X                                     |
| Military       | M83723 /74 (with pin contacts)             | X             | X-X                      | X                                     |

| Connector Type (Bayonet) | Connector Style | Service Class | Shell Size & Insert Arrg | Contact Type | Alt. Keying Position or Alt. Rotation | Modification Number |
|--------------------------|-----------------|---------------|--------------------------|--------------|---------------------------------------|---------------------|
| Commercial               | MB              | 34            | X                        | X-X          | X                                     | XXX                 |

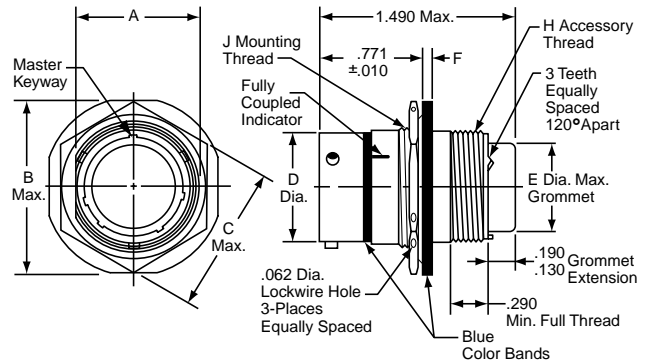

| Shell Size | A           | B Max. | C Max. | D Dia.      | E Dia. Max. | F         | H Accessory Thread Class 2A | J Mounting Thread Class 2A |
|------------|-------------|--------|--------|-------------|-------------|-----------|-----------------------------|----------------------------|
| 8          | .596/.590   | .979   | .829   | .536/.531   | .305        | .137/.097 | .5000-20 UNF                | .6250-20 UN                |
| 10         | .721/.715   | 1.104  | .954   | .659/.654   | .405        | .137/.097 | .6250-24 UNEF               | .7500-20 UNEF              |
| 12         | .908/.902   | 1.291  | 1.142  | .829/.824   | .531        | .113/.097 | .7500-20 UNEF               | .9375-20 UNEF              |
| 14         | .971/.965   | 1.391  | 1.205  | .898/.893   | .665        | .137/.097 | .8750-20 UNEF               | 1.0000-20 UNEF             |
| 16         | 1.096/1.090 | 1.516  | 1.329  | 1.025/1.020 | .790        | .137/.097 | 1.0000-20 UNEF              | 1.1250-20 UN               |
| 18         | 1.220/1.214 | 1.641  | 1.455  | 1.131/1.126 | .869        | .137/.097 | 1.0625-18 UNEF              | 1.2500-18 UNEF             |
| 20         | 1.345/1.339 | 1.766  | 1.579  | 1.256/1.251 | .994        | .137/.097 | 1.1875-18 UNEF              | 1.3750-18 UNEF             |
| 22         | 1.470/1.464 | 1.954  | 1.705  | 1.381/1.376 | 1.119       | .169/.128 | 1.3125-18 UNEF              | 1.5000-20 UNEF             |
| 24         | 1.595/1.589 | 2.079  | 1.829  | 1.506/1.501 | 1.244       | .168/.128 | 1.4375-18 UNEF              | 1.6250-18 UNEF             |

All dimensions for reference only.



# M83723/75 & /76 – MIL-DTL-83723, Series III

## Straight Plug with Bayonet Coupling



### PART #

To complete, see how to order page 127.

| Connector Type | Connector Style (Bayonet) and Contact Type | Service Class | Shell Size & Insert Arrg | Alt. Keying Position or Alt. Rotation |
|----------------|--|---------------|--------------------------|---------------------------------------|
| Military       | M83723 /75 (with socket contacts)          | X             | X-X                      | X                                     |
| Military       | M83723 /76 (with pin contacts)             | X             | X-X                      | X                                     |

| Connector Type (Bayonet) | Connector Style | Service Class | Shell Size & Insert Arrg | Contact Type | Alt. Keying Position or Alt. Rotation | Modification Number |
|--------------------------|-----------------|---------------|--------------------------|--------------|---------------------------------------|---------------------|
| Commercial               | MB              | 36            | X                        | X-X          | X                                     | XXX                 |

| Shell Size | A Dia. Max. | E Dia. Max. | H Accessory Thread Class 2A |
|------------|-------------|-------------|-----------------------------|
| 8          | .776        | .305        | .5000-20 UNF                |
| 10         | .906        | .405        | .6250-24 UNEF               |
| 12         | 1.078       | .531        | .7500-20 UNEF               |
| 14         | 1.141       | .665        | .8750-20 UNEF               |
| 16         | 1.266       | .790        | 1.0000-20 UNEF              |
| 18         | 1.375       | .869        | 1.0625-18 UNEF              |
| 20         | 1.510       | .994        | 1.1875-18 UNEF              |
| 22         | 1.625       | 1.119       | 1.3125-18 UNEF              |
| 24         | 1.760       | 1.244       | 1.4375-18 UNEF              |

All dimensions for reference only.

# M83723/77 & /78 – MIL-DTL-83723, Series III

## Straight Plug, Bayonet Coupling (with RFI grounding fingers)



### PART #

To complete, see how to order page 127.

| Connector Type | Connector Style (Bayonet) and Contact Type | Service Class | Shell Size & Insert Arrg | Alt. Keying Position or Alt. Rotation |
|----------------|--|---------------|--------------------------|---------------------------------------|
| Military       | M83723 /77 (with socket contacts)          | X             | X-X                      | X                                     |
| Military       | M83723 /78 (with pin contacts)             | X             | X-X                      | X                                     |

| Connector Type (Bayonet) | Connector Style | Service Class | Shell Size & Insert Arrg | Contact Type | Alt. Keying Position or Alt. Rotation | Modification Number |
|--------------------------|-----------------|---------------|--------------------------|--------------|---------------------------------------|---------------------|
| Commercial               | MB              | 38            | X                        | X-X          | X                                     | XXX                 |

| Shell Size | A Dia. Max. | E Dia. Max. | H Accessory Thread Class 2A |
|------------|-------------|-------------|-----------------------------|
| 8          | .776        | .305        | .5000-20 UNF                |
| 10         | .906        | .405        | .6250-24 UNEF               |
| 12         | 1.078       | .531        | .7500-20 UNEF               |
| 14         | 1.141       | .665        | .8750-20 UNEF               |
| 16         | 1.266       | .790        | 1.0000-20 UNEF              |
| 18         | 1.375       | .869        | 1.0625-18 UNEF              |
| 20         | 1.510       | .994        | 1.1875-18 UNEF              |
| 22         | 1.625       | 1.119       | 1.3125-18 UNEF              |
| 24         | 1.760       | 1.244       | 1.4375-18 UNEF              |

All dimensions for reference only.

- III 38999
- II SJT
- I Matrix 2 26482
- Matrix 2 26482
- Matrix Pyle 83723 III
- Crimp Rear Release Matrix 5015
- 26500 Pyle
- Circuit Board Printed
- Transient EMI Filter
- Fiber Optics
- High Speed Contacts
- Options Others

38999  
SJT I II III

26482  
Matrix 2

83723 III  
Matrix Pyle

5015  
Crimp Rear  
Release Matrix

26500 Pyle

Printed  
Circuit Board

EMI Filter  
Transient

Fiber Optics

High Speed  
Contacts

Options  
Others

|                           |                |  |               |                                |  |
|---------------------------|----------------|--|---------------|--------------------------------|--|
| 1.                        | 2.             | 3.   | 4.            | 5.                             |  |
| MIL-DTL-83723, Series III | Connector Type | Connector Style (Threaded) and Contact Type) | Service Class | Shell Size/ Insert Arrangement | Alternate Keying Position of Shell or Alternate Rotation of Insert |
| <b>MILITARY</b>           | <b>M83723</b>  | <b>/84</b>                                   | <b>R</b>      | <b>803</b>                     | <b>N</b>   |

|   |                           |                 |               |                                |              |  |                     |
|---|---------------------------|-----------------|---------------|--------------------------------|--------------|--|---------------------|
| 1.  | 2.                        | 3.              | 4.            | 5.                             | 6.           | 7.   |                     |
| Amphenol®/Matrix® MIL-DTL-83723, Series III | Connector Type (Threaded) | Connector Style | Service Class | Shell Size/ Insert Arrangement | Contact Type | Alternate Keying Position of Shell or Alternate Rotation of Insert | Modification Number |
| <b>COMMERCIAL</b>                           | <b>MT</b>                 | <b>34</b>       | <b>R</b>      | <b>0803</b>                    | <b>P</b>     | <b>7</b>   | <b>XXX</b>          |

**Step 1. Military Connector Type**

|               |   |
|---------------|---|
| <b>M83723</b> | <b>Designates MIL-DTL-83723 Series III Connectors</b> |
|---------------|---|

**Step 2. Select a Connector Style**

(Refer to military specification slash sheet number).

|            | Designates  |
|------------|---|
| <b>/82</b> | Wall Mount Receptacle with Socket Contacts                    |
| <b>/83</b> | Wall Mount Receptacle with Pin Contacts                       |
| <b>/84</b> | Jam Nut Receptacle with Socket Contacts                       |
| <b>/85</b> | Jam Nut Receptacle with Pin Contacts                          |
| <b>/86</b> | Standard Straight Plug with Socket Contacts                   |
| <b>/87</b> | Standard Straight Plug with Pin Contacts                      |
| <b>/91</b> | Straight Plug with RFI grounding, Socket Contacts             |
| <b>/92</b> | Straight Plug with RFI grounding, Pin Contacts                |
| <b>/95</b> | Straight Plug with Self-Locking Clutch Plate, Socket Contacts |
| <b>/96</b> | Straight Plug with Self-Locking Clutch Plate, Pin Contacts    |

**Step 3. Select a Service Class**

|          | Designates  |
|----------|---|
| <b>A</b> | Aluminum shell, black non-conductive anodize finish, fluid resistant insert |
| <b>R</b> | Aluminum shell, electroless nickel finish, fluid resistant insert           |
| <b>G</b> | Stainless steel shell, passivated, fluid resistant insert                   |
| <b>W</b> | Aluminum shell, olive drab cadmium plated, fluid resistant insert           |

See additional classes of MIL-DTL-83723, Series III which are available in the Amphenol/Pyle versions: Classes K, S, N - firewall, high temperature (200°C – 260°C) and Classes H and Y - hermetics. These are covered in the 83723 Pyle section of this catalog.

**Step 4. Select a Shell Size & Insert Arrangement from chart on pg. 124.**

Shell Size & Insert Arrangements are on page 124. First number represents Shell Size, second number is the Insert Arrangement. (Note that shell size 28 is not an MS connector, and should be ordered by commercial number.)

**Step 5. Select an Alternate Keying Position - Rotation of master key/keyway of shell.**

Use N for normal. Use 6, 7, 8, 9 or Y for alternate keying positions. See page 124 for descriptions.

**or Step 5. Select an Alternate Rotation of Insert.**

Use N for Normal. Use 1, 2, 3, 4, or 5 for alternate rotation of insert. See page 124 for descriptions.

For ordering information on accessories, such as protection caps and backshell hardware, contact Amphenol Aerospace, Sidney, NY.

**Step 1. Commercial Connector Type**

|           |   |
|-----------|---|
| <b>MT</b> | <b>Designates Amphenol®/Matrix® Threaded Coupling Connector</b> |
|-----------|---|

**Step 2. Select a Connector Style**

|           | Designates                                   |
|-----------|--|
| <b>30</b> | Wall Mount Receptacle                        |
| <b>34</b> | Jam Mount Receptacle                         |
| <b>36</b> | Standard Straight Plug                       |
| <b>38</b> | Straight Plug with RFI grounding fingers     |
| <b>37</b> | Straight Plug with Self-Locking Clutch Plate |

**Step 3. Select a Service Class**

|          | Designates   |
|----------|--|
| <b>A</b> | Aluminum shell, black non-conductive anodize finish, fluid resistant insert            |
| <b>R</b> | Aluminum shell, electroless nickel finish, fluid resistant insert                      |
| <b>G</b> | Stainless steel shell, passivated, fluid resistant insert                              |
| <b>W</b> | Aluminum shell, cadmium olive drab finish, corrosion resistant, fluid resistant insert |

See additional classes of MIL-DTL-83723, Series III which are available in the Amphenol/Pyle versions: Classes K, S, N - firewall, high temperature (200°C – 260°C) and Classes H and Y - hermetics. These are covered in the 83723 Pyle section of this catalog.

**Step 4. Select a Shell Size & Insert Arrangement from chart on pg. 124.**

Shell Size & Insert Arrangements are on page 124. First number represents Shell Size, second number is the Insert Arrangement.

**Step 5. Select a Contact Type**

|          | Designates      |
|----------|-----------------|
| <b>P</b> | Pin Contacts    |
| <b>S</b> | Socket Contacts |

**Step 6. Select an Alternate Keying Position - Rotation of master key/keyway of shell.**

Use 6, 7, 8, 9 or Y for alternate keying positions. No letter required for normal (No rotation position). See page 124 for descriptions.

**or Step 6. Select an Alternate Rotation of Insert.**

Use 1, 2, 3, 4, or 5 for alternate rotation of insert. No letter required for normal (No rotation position) See page 124 for descriptions.

**Step 7. Modification Number**

Consult Amphenol Aerospace for information.

# M83723/82 & /83 – MIL-DTL-83723, Series III

## Wall Mounting Receptacle with Threaded Coupling

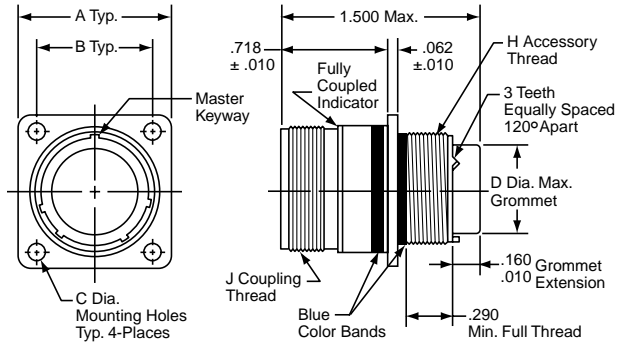

### PART #

To complete, see how to order page 130.

| Connector Type | Connector Style (Threaded) and Contact Type | Service Class | Shell Size & Insert Arrg | Alt. Keying Position or Alt. Rotation |
|----------------|---|---------------|--------------------------|---------------------------------------|
| Military       | M83723 /82 (with socket contacts)           | X             | X-X                      | X                                     |
| Military       | M83723 /83 (with pin contacts)              | X             | X-X                      | X                                     |

| Connector Type (Threaded) | Connector Style | Service Class | Shell Size & Insert Arrg | Contact Type | Alt. Keying Position or Alt. Rotation | Modification Number |
|---------------------------|-----------------|---------------|--------------------------|--------------|---------------------------------------|---------------------|
| Commercial                | MT              | 30            | X                        | X-X          | X                                     | XXX                 |

| Shell Size | A ±.005 | B ±.005 | C Dia.    | D Dia. Max. | H Accessory Thread Class 2A | J Coupling Thread Class 2B |
|------------|---------|---------|-----------|-------------|-----------------------------|----------------------------|
| 8          | .812    | .594    | .125/.116 | .305        | .5000-20 UNEF               | .5625-24 UNEF              |
| 10         | .937    | .719    | .125/.116 | .405        | .6250-24 UNEF               | .6875-24 UNEF              |
| 12         | 1.031   | .812    | .125/.116 | .531        | .7500-20 UNEF               | .8750-20 UNEF              |
| 14         | 1.125   | .906    | .125/.116 | .665        | .8750-20 UNEF               | .9375-20 UNEF              |
| 16         | 1.250   | .969    | .125/.116 | .790        | 1.0000-20 UNEF              | 1.0625-18 UNEF             |
| 18         | 1.343   | 1.062   | .125/.116 | .869        | 1.0625-18 UNEF              | 1.1875-18 UNEF             |
| 20         | 1.437   | 1.156   | .125/.116 | .994        | 1.1875-18 UNEF              | 1.3125-18 UNEF             |
| 22         | 1.562   | 1.250   | .125/.116 | 1.119       | 1.3125-18 UNEF              | 1.4375-18 UNEF             |
| 24         | 1.703   | 1.375   | .154/.145 | 1.244       | 1.4375-18 UNEF              | 1.5625-18 UNEF             |
| 28*        | 2.000   | 1.562   | .154/.145 | 1.465       | 1.7500-18 UNS               | 1.8125-16 UN               |

\* Shell size 28 is not a MS connector; order by commercial part number.

All dimensions for reference only.

# M83723/84 & /85 – MIL-DTL-83723, Series III

## Jam Nut Receptacle with Threaded Coupling

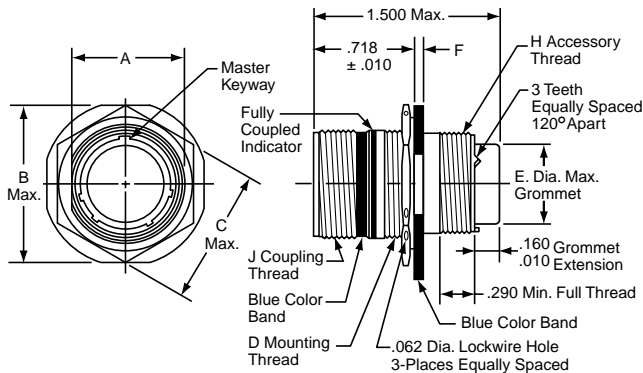

### PART #

To complete, see how to order page 130.

| Connector Type | Connector Style (Threaded) and Contact Type | Service Class | Shell Size & Insert Arrg | Alt. Keying Position or Alt. Rotation |
|----------------|---|---------------|--------------------------|---------------------------------------|
| Military       | M83723 /84 (with socket contacts)           | X             | X-X                      | X                                     |
| Military       | M83723 /85 (with pin contacts)              | X             | X-X                      | X                                     |

| Connector Type (Threaded) | Connector Style | Service Class | Shell Size & Insert Arrg | Contact Type | Alt. Keying Position or Alt. Rotation | Modification Number |
|---------------------------|-----------------|---------------|--------------------------|--------------|---------------------------------------|---------------------|
| Commercial                | MT              | 34            | X                        | X-X          | X                                     | XXX                 |

| Shell Size | A ±.003 | B Max. | C Max. | D Mounting Thread | E Dia. Max. | F         | H Accessory Thread Class 2A | J Coupling Thread Class 2A |
|------------|---------|--------|--------|-------------------|-------------|-----------|-----------------------------|----------------------------|
| 8          | .593    | .980   | .828   | .6250-20 UN       | .305        | .137/.097 | .5000-20 UNEF               | .5625-24 UNEF              |
| 10         | .718    | 1.104  | .953   | .7500-20 UNEF     | .405        | .137/.097 | .6250-24 UNEF               | .6875-24 UNEF              |
| 12         | .905    | 1.291  | 1.140  | .9375-20 UNEF     | .531        | .137/.097 | .7500-20 UNEF               | .8750-20 UNEF              |
| 14         | .968    | 1.391  | 1.250  | 1.0000-20 UNEF    | .665        | .137/.097 | .8750-20 UNEF               | .9375-20 UNEF              |
| 16         | 1.093   | 1.516  | 1.329  | 1.1250-18 UNEF    | .790        | .137/.097 | 1.0000-20 UNEF              | 1.0625-18 UNEF             |
| 18         | 1.217   | 1.641  | 1.455  | 1.2500-18 UNEF    | .869        | .137/.097 | 1.0625-18 UNEF              | 1.1875-18 UNEF             |
| 20         | 1.342   | 1.766  | 1.642  | 1.3750-18 UNEF    | .994        | .137/.097 | 1.1875-18 UNEF              | 1.3125-18 UNEF             |
| 22         | 1.467   | 1.954  | 1.705  | 1.5000-18 UNEF    | 1.119       | .148/.128 | 1.3125-18 UNEF              | 1.4375-18 UNEF             |
| 24         | 1.592   | 2.079  | 1.892  | 1.6250-18 UNEF    | 1.244       | .148/.128 | 1.4375-18 UNEF              | 1.5625-18 UNEF             |
| 28*        | 1.840   | 2.330  | 2.145  | 1.8750-20 UN      | 1.465       | .148/.128 | 1.7500-18 UNS               | 1.8125-16 UN               |

\* Shell size 28 is not a MS connector; order by commercial part number.

All dimensions for reference only.

III 38999  
II 1  
I SJT

Matrix 2 26482

Matrix Pyle 83723 III

Release Matrix 5015  
Crimp Rear

26500 Pyle

Printed Circuit Board

EMI Filter Transient

Fiber Optics

High Speed Contacts

Options Others

38999  
SJT I II III

26482  
Matrix 2

83723 III  
Matrix Pyle

5015  
Crimp Rear  
Release Matrix

26500 Pyle

Printed  
Circuit Board

EMI Filter  
Transient

Fiber Optics

High Speed  
Contacts

Options  
Others

**PART #**

To complete, see how to order page 130.

| Connector Type | Connector Style (Threaded) and Contact Type | Service Class | Shell Size & Insert Arrg | Alt. Keying Position or Alt. Rotation |
|----------------|---|---------------|--------------------------|---------------------------------------|
| Military       | M83723 /86 (with socket contacts)           | X             | X-X                      | X                                     |
| Military       | M83723 /87 (with pin contacts)              | X             | X-X                      | X                                     |

| Connector Type (Threaded) | Connector Style | Service Class | Shell Size & Insert Arrg | Contact Type | Alt. Keying Position or Alt. Rotation | Modification Number |
|---------------------------|-----------------|---------------|--------------------------|--------------|---------------------------------------|---------------------|
| Commercial                | MT              | 36            | X                        | X-X          | X                                     | XXX                 |

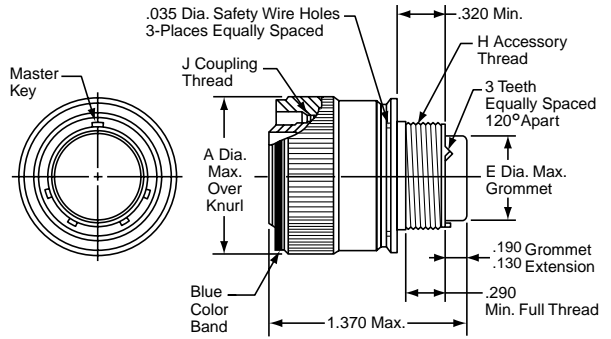

| Shell Size | A Dia. Max. | E Dia. Max. | H Accessory Thread Class 2A | J Coupling Thread Class 2B |
|------------|-------------|-------------|-----------------------------|----------------------------|
| 8          | .756        | .305        | .5000-20 UNF                | .5625-24 UNEF              |
| 10         | .906        | .405        | .6250-24 UNEF               | .6875-24 UNEF              |
| 12         | 1.078       | .531        | .7500-20 UNEF               | .8750-20 UNEF              |
| 14         | 1.141       | .665        | .8750-20 UNEF               | .9375-20 UNEF              |
| 16         | 1.266       | .790        | 1.0000-20 UNEF              | 1.0625-18 UNEF             |
| 18         | 1.375       | .869        | 1.0625-18 UNEF              | 1.1875-18 UNEF             |
| 20         | 1.510       | .994        | 1.1875-18 UNEF              | 1.3125-18 UNEF             |
| 22         | 1.625       | 1.119       | 1.3125-18 UNEF              | 1.4375-18 UNEF             |
| 24         | 1.760       | 1.244       | 1.4375-18 UNEF              | 1.5625-18 UNEF             |
| 28*        | 2.050       | 1.465       | 1.7500-18 UNS               | 1.8125-18 UN               |

\* Shell size 28 is not a MS connector; order by commercial part number. All dimensions for reference only.

**M83723/91 & /92 – MIL-DTL-83723, Series III**  
Straight Plug, Threaded Coupling (With RFI Grounding Fingers)

**PART #**

To complete, see how to order page 130.

| Connector Type | Connector Style (Threaded) and Contact Type | Service Class | Shell Size & Insert Arrg | Alt. Keying Position or Alt. Rotation |
|----------------|---|---------------|--------------------------|---------------------------------------|
| Military       | M83723 /91 (with socket contacts)           | X             | X-X                      | X                                     |
| Military       | M83723 /92 (with pin contacts)              | X             | X-X                      | X                                     |

| Connector Type (Threaded) | Connector Style | Service Class | Shell Size & Insert Arrg | Contact Type | Alt. Keying Position or Alt. Rotation | Modification Number |
|---------------------------|-----------------|---------------|--------------------------|--------------|---------------------------------------|---------------------|
| Commercial                | MT              | 38            | X                        | X-X          | X                                     | XXX                 |

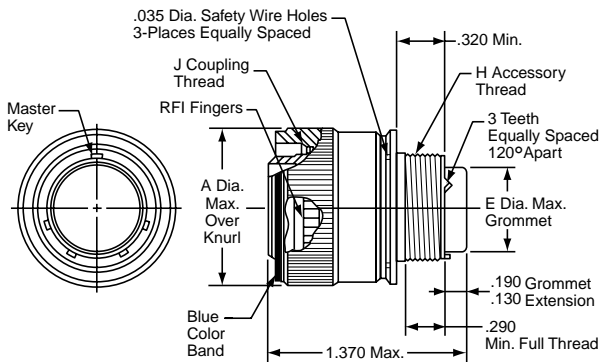

| Shell Size | A Dia. Max. | E Dia. Max. | H Accessory Thread Class 2A | J Coupling Thread Class 2B |
|------------|-------------|-------------|-----------------------------|----------------------------|
| 8          | .756        | .305        | .5000-20 UNF                | .5625-24 UNEF              |
| 10         | .906        | .405        | .6250-24 UNEF               | .6875-24 UNEF              |
| 12         | 1.078       | .531        | .7500-20 UNEF               | .8750-20 UNEF              |
| 14         | 1.141       | .665        | .8750-20 UNEF               | .9375-20 UNEF              |
| 16         | 1.266       | .790        | 1.0000-20 UNEF              | 1.0625-18 UNEF             |
| 18         | 1.375       | .869        | 1.0625-18 UNEF              | 1.1875-18 UNEF             |
| 20         | 1.510       | .994        | 1.1875-18 UNEF              | 1.3125-18 UNEF             |
| 22         | 1.625       | 1.119       | 1.3125-18 UNEF              | 1.4375-18 UNEF             |
| 24         | 1.760       | 1.244       | 1.4375-18 UNEF              | 1.5625-18 UNEF             |
| 28*        | 2.050       | 1.465       | 1.7500-18 UNS               | 1.8125-18 UN               |

\* Shell size 28 is not a MS connector; order by commercial part number. All dimensions for reference only.

# M83723/95 & /96 – MIL-DTL-83723, Series III

## Straight Plug with Threaded Coupling (Self-Locking)

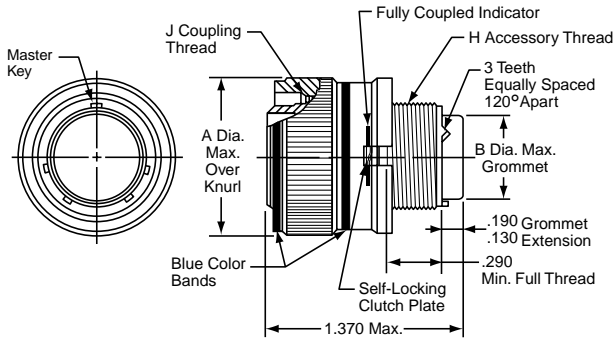

### PART #

To complete, see how to order page 130.

| Connector Type | Connector Style (Threaded) and Contact Type | Service Class              | Shell Size & Insert Arrg | Alt. Keying Position or Alt. Rotation |   |
|----------------|---|----------------------------|--------------------------|---------------------------------------|---|
| Military       | M83723                                      | /95 (with socket contacts) | X                        | X-X                                   | X |
| Military       | M83723                                      | /96 (with pin contacts)    | X                        | X-X                                   | X |

| Connector Type (Threaded) | Connector Style | Service Class | Shell Size & Insert Arrg | Contact Type | Alt. Keying Position or Alt. Rotation | Modification Number |
|---------------------------|-----------------|---------------|--------------------------|--------------|---------------------------------------|---------------------|
| Commercial                | MT              | 37            | X                        | X-X          | X                                     | XXX                 |

| Shell Size | A Dia. Max. | B Dia. Max. | H Accessory Thread Class 2A | J Coupling Thread Class 2B |
|------------|-------------|-------------|-----------------------------|----------------------------|
| 8          | .832        | .305        | .5000-20 UNEF               | .5625-24 UNEF              |
| 10         | .959        | .405        | .6250-24 UNEF               | .6875-24 UNEF              |
| 12         | 1.097       | .531        | .7500-20 UNEF               | .8750-20 UNEF              |
| 14         | 1.236       | .665        | .8750-20 UNEF               | .9375-20 UNEF              |
| 16         | 1.360       | .790        | 1.0000-20 UNEF              | 1.0625-18 UNEF             |
| 18         | 1.428       | .869        | 1.0625-18 UNEF              | 1.1875-18 UNEF             |
| 20         | 1.586       | .994        | 1.1875-18 UNEF              | 1.3125-18 UNEF             |
| 22         | 1.703       | 1.119       | 1.3125-18 UNEF              | 1.4375-18 UNEF             |
| 24         | 1.846       | 1.244       | 1.4375-18 UNEF              | 1.5625-18 UNEF             |
| 28*        | 2.165       | 1.465       | 1.7500-18 UNS               | 1.8125-18 UN               |

\* Shell size 28 is not a MS connector; order by commercial part number. All dimensions for reference only.

III  
II  
I  
SJT  
38999

Matrix 2  
26482

Matrix Pyle  
83723 III

Release Matrix  
Crimp Rear  
5015

26500 Pyle

Printed  
Circuit Board

EMI Filter  
Transient

Fiber Optics

High Speed  
Contacts

Options  
Others



38999  
SJT I II III

26482  
Matrix 2

83723 III  
Matrix Pyle

5015  
Crimp Rear  
Release Matrix

26500 Pyle

Printed  
Circuit Board

EMI Filter  
Transient

Fiber Optics

High Speed  
Contacts

Options  
Others

| 1.                        | 2.             | 3.  | 4.            | 5.                             |  |
|---------------------------|----------------|---|---------------|--------------------------------|--|
| MIL-DTL-83723, Series III | Connector Type | Connector Style (Quick-Disconnect) and Contact Type | Service Class | Shell Size/ Insert Arrangement | Alternate Keying Position of Shell or Alternate Rotation of Insert |
| <b>MILITARY</b>           | <b>M83723</b>  | <b>/66</b>  | <b>R</b>      | <b>0803</b>                    | <b>N</b>   |

| 1.  | 2.                                | 3.              | 4.            | 5.                             | 6.           | 7.   |                     |
|---|-----------------------------------|-----------------|---------------|--------------------------------|--------------|--|---------------------|
| Amphenol®/Matrix® MIL-DTL-83723, Series III | Connector Type (Quick-Disconnect) | Connector Style | Service Class | Shell Size/ Insert Arrangement | Contact Type | Alternate Keying Position of Shell or Alternate Rotation of Insert | Modification Number |
| <b>COMMERCIAL</b>                           | <b>MQ</b>                         | <b>35</b>       | <b>R</b>      | <b>0803</b>                    | <b>P</b>     | <b>7</b>   | <b>XXX</b>          |

**Step 1. Military Connector Type**

|               |   |
|---------------|---|
| <b>M83723</b> | <b>Designates MIL-DTL-83723 Series III Connectors</b> |
|---------------|---|

**Step 2. Select a Connector Style**

(Refer to military specification slash sheet number).

|            | Designates                                     |
|------------|--|
| <b>/66</b> | Straight Plug without Lanyard, Pin Contacts    |
| <b>/67</b> | Straight Plug without Lanyard, Socket Contacts |
| <b>/68</b> | Straight Plug with Lanyard, Pin Contacts       |
| <b>/69</b> | Straight Plug with Lanyard, Socket Contacts    |

**Step 3. Select a Service Class**

|          | Designates  |
|----------|---|
| <b>A</b> | Aluminum shell, black non-conductive anodize finish, fluid resistant insert |
| <b>R</b> | Aluminum shell, electroless nickel finish, fluid resistant insert           |
| <b>G</b> | Stainless steel shell, passivated, fluid resistant insert                   |
| <b>W</b> | Aluminum shell, olive drab cadmium plated, fluid resistant insert           |

See additional classes of MIL-DTL-83723, Series III which are available in the Amphenol/Pyle versions: Classes K, S, N - firewall, high temperature (200°C – 260°C) and Classes H and Y - hermetics. These are covered in the 83723 Pyle section of this catalog.

**Step 4. Select a Shell Size & Insert**

Arrangement from chart on page 124.

Shell Size & Insert Arrangements are together in one chart. First number represents Shell Size, second number is the Insert Arrangement. (Note that shell size 28 is not an MS connector, and should be ordered by commercial number.)

**Step 5. Select an Alternate Keying Position - Rotation of master key/keyway of shell.**

Use N for normal. Use 6, 7, 8, 9 or Y for alternate keying positions. See page 124 for descriptions.

**or Step 5. Select an Alternate Rotation of Insert.**

Use N for Normal. Use 1, 2, 3, 4, or 5 for alternate rotation of insert. See page 124 for descriptions.

For ordering information on accessories, such as protection caps and backshell hardware, contact Amphenol Aerospace, Sidney, NY.

**Step 1. Commercial Connector Type**

|           |   |
|-----------|---|
| <b>MQ</b> | <b>Designates Amphenol®/Matrix® Quick-Disconnect Coupling Connector</b> |
|-----------|---|

**Step 2. Select a Connector Style**

|           | Designates   |
|-----------|--|
| <b>35</b> | Straight Plug with Lanyard   |
| <b>36</b> | Straight Plug without Lanyard  |
| <b>38</b> | Straight Plug with Lanyard, RFI grounding fingers (No Mil-Spec equivalent) |

**Step 3. Select a Service Class**

|          | Designates   |
|----------|--|
| <b>A</b> | Aluminum shell, black non-conductive anodize finish, fluid resistant insert            |
| <b>R</b> | Aluminum shell, electroless nickel finish, fluid resistant insert                      |
| <b>G</b> | Stainless steel shell, passivated, fluid resistant insert                              |
| <b>W</b> | Aluminum shell, cadmium olive drab finish, corrosion resistant, fluid resistant insert |

See additional classes of MIL-DTL-83723, Series III which are available in the Amphenol/Pyle versions: Classes K, S, N - firewall, high temperature (200°C – 260°C) and Classes H and Y - hermetics. These are covered in the 83723 Pyle section of this catalog.

**Step 4. Select a Shell Size & Insert**

Arrangement from chart on page 124.

Shell Size & Insert Arrangements are together in one chart. First number represents Shell Size, second number is the Insert Arrangement.

**Step 5. Select a Contact Type**

|          | Designates      |
|----------|-----------------|
| <b>P</b> | Pin Contacts    |
| <b>S</b> | Socket Contacts |

**Step 6. Select an Alternate Keying Position - Rotation of master key/keyway of shell.**

Use 6, 7, 8, 9 or Y for alternate keying positions. No letter required for normal (No rotation position) See page 124 for descriptions.

**or Step 6. Select an Alternate Rotation of Insert.**

Use 1, 2, 3, 4, or 5 for alternate rotation of insert. No letter required for normal (No rotation position). See page 124 for descriptions.

**Step 7. Modification Number**

Consult Amphenol Aerospace for information.



# M83723/66 & /67 – MIL-DTL-83723, Series III

## Quick-Disconnect Plug



### PART #

To complete, see how to order page X.

|          | Connector Type | Connector Style (Quick-Disconnect) and Contact Type | Service Class | Shell Size & Insert Arrg | Alt. Keying Position or Alt. Rotation |
|----------|----------------|---|---------------|--------------------------|---------------------------------------|
| Military | M83723         | /67 (with socket contacts)                          | X             | X-X                      | X                                     |
| Military | M83723         | /66 (with pin contacts)                             | X             | X-X                      | X                                     |

|            | Connector Type (Quick-Disconnect) | Connector Style | Service Class | Shell Size & Insert Arrg | Contact Type | Alt. Keying Position or Alt. Rotation | Modification Number |
|------------|-----------------------------------|-----------------|---------------|--------------------------|--------------|---------------------------------------|---------------------|
| Commercial | MQ                                | 36              | X             | X-X                      | X            | X                                     | XXX                 |

# M83723/68 & /69 – MIL-DTL-83723, Series III

## Quick-Disconnect Plug with Lanyard

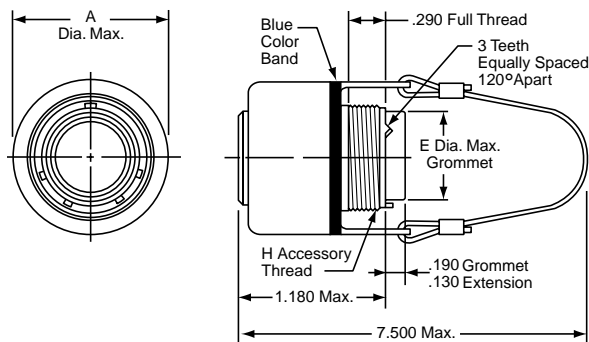

### PART #

To complete, see how to order page X.

|          | Connector Type | Connector Style (Quick-Disconnect) and Contact Type | Service Class | Shell Size & Insert Arrg | Alt. Keying Position or Alt. Rotation |
|----------|----------------|---|---------------|--------------------------|---------------------------------------|
| Military | M83723         | /69 (with socket contacts)                          | X             | X-X                      | X                                     |
| Military | M83723         | /68 (with pin contacts)                             | X             | X-X                      | X                                     |

|                                     | Connector Type (Quick-Disconnect) | Connector Style | Service Class | Shell Size & Insert Arrg | Contact Type | Alt. Keying Position or Alt. Rotation | Modification Number |
|-------------------------------------|-----------------------------------|-----------------|---------------|--------------------------|--------------|---------------------------------------|---------------------|
| Commercial                          | MQ                                | 35              | X             | X-X                      | X            | X                                     | XXX                 |
| Commercial (No Mil-spec Equivalent) | MQ                                | 38              | X             | X-X                      | X            | X                                     | XXX                 |

## Adapter for Mating Quick-Disconnect Plugs with Receptacles

| Shell Size | A Dia. Max. | E Dia. Max. | H Accessory Thread Class 2A |
|------------|-------------|-------------|-----------------------------|
| 8          | 1.095       | .305        | .5000-20 UNF                |
| 10         | 1.240       | .405        | .6250-24 UNEF               |
| 12         | 1.432       | .531        | .7500-20 UNEF               |
| 14         | 1.490       | .665        | .8750-20 UNEF               |
| 16         | 1.711       | .790        | 1.0000-20 UNEF              |
| 18         | 1.815       | .869        | 1.0625-18 UNEF              |
| 20         | 1.962       | .994        | 1.1875-18 UNEF              |
| 22         | 2.070       | 1.119       | 1.3125-18 UNEF              |
| 24         | 2.195       | 1.244       | 1.4375-18 UNEF              |

### Receptacle Adapter

Required to mate the quick-disconnect plug with receptacle. Not furnished with the quick-disconnect plug; must be ordered separately.

Note: Use Locktite Material on the threads for a permanent installation to the shell.

How to Order Adapter by Commercial Part Number  
2500-007-0X XX

Finish | Shell Size

00 designates aluminum, electroless nickel, Class R  
01 designates aluminum, hard anodize, Class A  
03 designates aluminum, cadmium plate, Class W  
02 designates stainless steel, Class G

How to Order Adapter by Military Part Number  
M83723/70 X XX

Finish | Shell Size

R designates aluminum, electroless nickel, Class R  
A designates aluminum, hard anodize, Class A  
W designates aluminum, cadmium plate, Class W  
G designates stainless steel, Class G



- III 38999
- II 26482
- I Matrix 2
- SJT
- Matrix 2
- 83723 III
- Matrix Pyle
- 5015
- Crimp Rear Release Matrix
- 26500 Pyle
- Printed Circuit Board
- EM1 Filter Transient
- Fiber Optics
- High Speed Contacts
- Options Others

#### MIL-DTL-83723, SERIES III CRIMP CONTACTS

| Contact Size | Wire Range |                 | Socket Contacts      | Pin Contacts         |
|--------------|------------|-----------------|----------------------|----------------------|
|              | AWG        | mm <sup>2</sup> | Military Part Number | Military Part Number |
| 20           | 24-20      | 0.2-0.6         | M39029/5-115         | M39029/4-110         |
| 16           | 20-16      | 0.5-1.4         | M39029/5-116         | M39029/4-111         |
| 12           | 14-12      | 2-3             | M39029/5-118         | M39029/4-113         |

#### CONTACT CURRENT RATING AND RETENTION

| Contact Size* | Current Rating |                         | Contact Retention |       |
|---------------|----------------|-------------------------|-------------------|-------|
|               | Amperes Max.   | Voltage Drop Millivolts | Axial Load        |       |
|               |                |                         | lb.               | N     |
| 20            | 7.5            | 35                      | 20                | 89.0  |
| 16            | 13.0           | 25                      | 25                | 111.2 |
| 12            | 23.0           | 25                      | 30                | 133.4 |

#### SEALING PLUGS

| Contact Size | Sealing Plugs        |                             |
|--------------|----------------------|-----------------------------|
|              | Military Part Number | Amphenol/Matrix Part Number |
| 20           | MS27488-20           | 3400-043-0020               |
| 16           | MS27488-16           | 3400-043-0016               |
| 12           | MS27488-12           | 3400-043-0012               |

\* Organize individual circuits to maintain heat rise within operating temperature requirements.

#### CRIMPING TOOLS

| Contact Size | Wire Range |                 | Finished Wire Dia. Range |           | Crimping Tool Part Number  | Turret or Positioner Part Number |
|--------------|------------|-----------------|--------------------------|-----------|----------------------------|----------------------------------|
|              | AWG        | mm <sup>2</sup> | Inch                     | mm        |                            |                                  |
| 20           | 24-20      | 0.2-0.6         | .040-.083                | 1.02-2.11 | M22520/1-01 or M22520/2-01 | M22520/1-02 or M22520/2-02       |
| 16           | 20-16      | 0.5-1.4         | .053-.103                | 1.34-2.62 | M22520/1-01                | M22520/1-02                      |
| 12           | 14-12      | 2-3             | .097-.158                | 2.46-4.01 | M22520/1-01                | M22520/1-02                      |

#### INSERTION/REMOVAL TOOLS

| Contact Size | Color Code   | Military Part Number | Amphenol/Matrix Part Number |
|--------------|--------------|----------------------|-----------------------------|
| 20           | Red/White    | M81969/14-11         | 6500-001-0020               |
| 16           | Blue/White   | M81969/14-03         | 6500-001-0016               |
| 12           | Yellow/White | M81969/14-04         | 6500-001-0012               |

Note: Each connector is furnished with contacts. One spare for inserts requiring 1 to 26 of each contact, two spares for inserts with more than 26 contacts, and a minimum of one sealing plug up to 10% of the number of contacts.

38999  
SJT I II III

26482  
Matrix 2

83723 III  
Matrix Pyle

5015  
Crimp Rear Release Matrix

26500 Pyle

Printed  
Circuit Board

EMI Filter  
Transient

Fiber Optics

High Speed  
Contacts

Options  
Others

# Amphenol MIL-DTL-83723, Series III, Pyle®

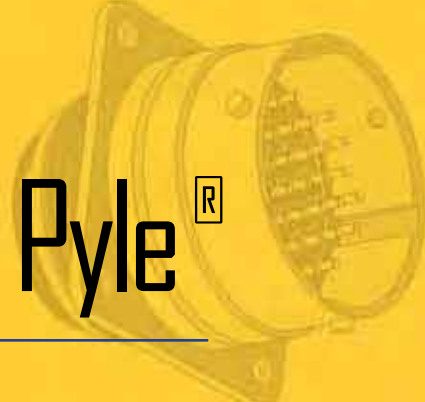

## TABLE OF CONTENTS

### MIL-DTL-83723, Series III, Pyle®

- Table of Contents . . . . . 137
- Design Features, Customer Options, Manufacturer's Specifications . 138, 139
- Quick Reference of Choices - Threaded Styles . . . . . 140-142
- Quick Reference of Choices - Bayonet Styles. . . . . 143
- Quick Reference of Choices - Hermetic Receptacles, Threaded . . 144, 145
- Insert Availability, Alternate Keying Positions . . . . . 146
- Insert Arrangement Drawings . . . . . 147, 148
- How to Order - Military or Commercial . . . . . 149
- How to Order - Pyle Commercial Designed to Meet GE Specifications . . 150
- How to Order - Boeing (BACC63CM/CN) or Pyle Comm. Equivalent. . . 151
- How to Order - ASD Designation. . . . . 152
- How to Order - Pyle Commercial Equivalents to ASD Designations/  
European Standards . . . . . 153
- How to Order - ESC10/11 for SBAC and Rolls Royce Standards . . . . 154
- How to Order - Pyle Commercial Equivalent to ESC11/  
European Specifications - Scoop-Proof only . . . . . 155
- How to Order - Hermetic, Military or Commercial . . . . . 156

**Threaded Shell Styles:**

- Square Flange Receptacle . . . . . 157
- Jam Nut (D-Hole Mount) Receptacle . . . . . 158
- Straight Plug & Non-Decoupling Plug . . . . . 159

**Bayonet Shell Styles:**

- Square Flange Receptacle . . . . . 160
- Jam Nut (D-Hole Mount) Receptacle . . . . . 161
- Straight Plug . . . . . 162

**Hermetic Shell Styles:**

- Square Flange Receptacle . . . . . 163
- Jam Nut (D-Hole Mount) Receptacle . . . . . 164
- Solder Mount/Weld Mount Receptacle . . . . . 165
- Contacts, Sealing Plugs, Tools . . . . . 166-169



### MIL-DTL-83723 Series III, Pyle® Typical Markets:

- Military & Commercial Aviation
  - High Temperature Applications
- Military Vehicles



**Amphenol Aerospace offers the Pyle® Product line of MIL-DTL-83723\*, Series III Connectors.**

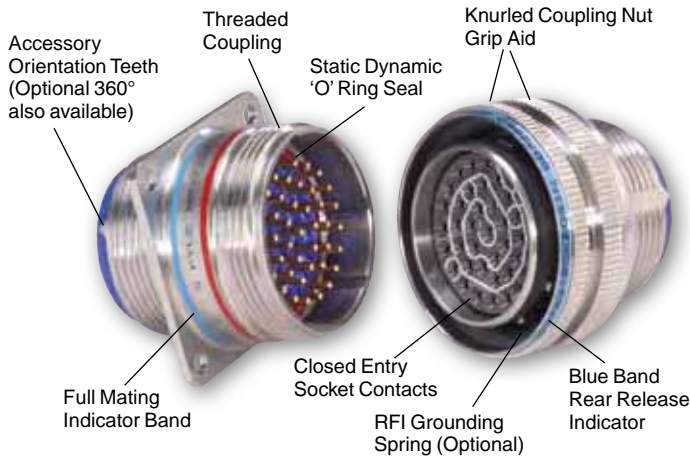

Amphenol/Pyle 83723 Series III high temperature styles are capable of operation at 260° C/500°F. A 100% scoop-proof version of the high temperature connector is also available under specification ESC11/Pyle HTK Series. In addition, this connector series incorporates a unique sealing grommet that is capable of sealing on standard diameter wire as well as Kapton wire of reduced diameter.

The Pyle 83723 family provides connectors in environmental, firewall and hermetic classes that exceed the most stringent specification requirements.

**MIL-DTL-83723, Series III Connectors are Available in a Wide Variety of Styles:**

**THREADED STYLE CONNECTORS**

- Stainless steel shells\*\* provide corrosion resistance
- Metal to metal bottoming
- Unique sealing grommet accepts a wide range of wire diameters
- Patented non-decoupling device in plugs - a self-locking clutch plate that provides greater resistance to decoupling than coupling during vibration

**BAYONET STYLE CONNECTORS**

- Same quality features of the threaded style, but with 3 point bayonet coupling - quick turn to lock, visual confirmation of complete coupling

**HIGH TEMPERATURE STYLE CONNECTORS**

- High temperature connector materials and contacts provide operation to 200°C and Firewall capability to 260°C
- Improved metal to metal bottoming design
- Unique sealing grommet accepts a wide range of wire diameters
- Improved 360° accessory orientation teeth provide greater performance under vibration
- Patented non-decoupling device (torque differential)
- Improved shell to shell conductivity with optional RFI grounding fingers
- Styles available that meet several European specifications, General Electric and Rolls Royce specifications

**HERMETIC STYLE CONNECTORS**

- Hermetic styles are available in threaded receptacles with solderwell or flat eyelet termination
- Designed for environmental moisture sealing with fused compression glass sealed inserts
- High temperature hermetics 200°C and 260°C Firewall

**Design Features (Threaded Style Shown)**

The Amphenol MIL-DTL-83723 Series III family of connectors includes styles from Pyle National. These have proven technology for severe environments and are widely used in commercial and military aerospace markets. Amphenol/Pyle 83723 connectors incorporate many advantageous features, such as a unique threaded coupling mechanism that provides greater resistance to decoupling. This coupling mechanism eliminates the need for safety wiring and tends to couple during vibration - thus offering the user added assurance and a margin of safety.

**SERVICE RATINGS**

| Service Rating | Recommended Operating AC Voltage at Sea Level | Test Voltage AC (RMS), 60 cps |            |            |             |
|----------------|---|-------------------------------|------------|------------|-------------|
|                |   | Sea Level                     | 50,000 ft. | 70,000 ft. | 110,000 ft. |
| I              | 600   | 1,500                         | 500        | 375        | 200         |

Please note that the electrical data given is not an establishment of electrical safety factors. This is left entirely in the designer's hands as he can best determine which peak voltage, switching surges, transients, etc. can be expected in a particular circuit.

\* MIL-DTL-83723 supercedes MIL-C-83723.

\*\* The Amphenol Pyle 83723 family is offered in stainless steel shell classes. See the Amphenol Matrix 83723 family for aluminum shell classes, in the preceding section of this catalog.

- 38999 SJT I II III
- 26482 Matrix 2
- 83723 III Matrix Pyle
- 5015 Crimp Rear Release Matrix
- 26500 Pyle
- Printed Circuit Board
- EMI Filter Transient
- Fiber Optics
- High Speed Contacts
- Options Others



# MIL-DTL-83723, Series III, Pyle®

## Manufacturer's Specifications



The Amphenol/Pyle® Product line of MIL-DTL-83723\*, Series III Connectors was developed for the higher operating temperatures inherent in today's high performance aircraft and aircraft engines.

These connectors meet the performance requirements of the following manufacturer's specifications:

- Boeing BACC63CM/CN\* Firewall
- European: ASD† EN2997
- General Electric: M50TF3564
- Rolls Royce/SBAC: ESC10 and ESC11



**ESC11  
Engine Connector**

III  
II  
I  
SJT  
38999

Matrix 2  
26482

Matrix Pyle  
83723 III

Release Matrix  
5015  
Crimp Rear

26500 Pyle

Printed  
Circuit Board

EMI Filter  
Transient

Fiber Optics

High Speed  
Contacts

Options  
Others

### MIL-DTL-83723, SERIES III CONNECTOR PERFORMANCE CHARACTERISTICS

|                                   |   |
|-----------------------------------|---|
| <b>Operating Temperature Data</b> | Std: -85°F (-65°C) to 392°F (200°C)<br>Class K types meet fireproof test per MIL-DTL-83723 2000°F (1093°C)<br>High Temperature Series: Operates at 500°F (260°C)  |
| <b>Altitude</b>                   | Sea Level to 110,000 feet   |
| <b>Voltage Breakdown Rating</b>   | Service Rating I<br>Sea Level .....1,500      50,000 ft. ....500<br>70,000 ft. .... 375      110,000 ft. .... 200   |
| <b>Contact Rating</b>             | Size 20 contacts ... 7.5 amperes max.<br>Size 16 contacts ... 13.0 amperes max.<br>Size 12 contacts ... 23 amperes max.   |
| <b>Contact Retention Strength</b> | Exceeds MIL-DTL-83723 requirements  |
| <b>Connector Durability</b>       | 500 cycles per MIL-DTL-83723 for threaded coupling;<br>500 cycles per General Electric M50TF2321 for non-decoupling styles  |
| <b>Humidity</b>                   | To 98% relative humidity, including condensation  |
| <b>Exposure</b>                   | Freezing rain   |
| <b>Non-Decoupling</b>             | Exceeds requirements of MIL-DTL-83723/95 and 96.  |
| <b>Vibration</b>                  | Meets MIL-DTL-83723 of 41.7G's for 16 hours.; Boeing BACC63CM/CN for 36 hours<br>General Electric vibration spec. M50TF2321 and M50TF2238 for 36 hours, which includes:<br><b>Temp. Extremes      G Level      Time Length</b><br>Room Temp. .... 60 G's ..... 12 hrs. (4 hrs. each axis)<br>-65°F ±5°F ..... 60 G's ..... 12 hrs. (4 hrs. each axis)<br>350°F ±5°F ..... 60 G's ..... 12 hrs. (4 hrs. each axis) |

### HERMETIC CONNECTOR PERFORMANCE CHARACTERISTICS

|  |   |
|--|---|
| <b>Thermal Shock</b>                             | No damage detrimental to the operation of the connector occurs when subjected to 10 cycles of thermal shock from 0°C to 90°C and back to 0°C.   |
| <b>Physical Shock (Mated)</b>                    | 300 G's   |
| <b>Moisture Resistance (Mated)</b>               | 500 Megohms   |
| <b>Insulation Resistance, High Temp. (Mated)</b> | 500 Megohms   |
| <b>Corrosion (Unmated)</b>                       | Complies with MIL-DTL-83723 Req.  |
| <b>Temperature Life</b>                          | Fully functional for 1000 hours at 200°C (392°F) ambient. Internal temperature 238°C (460°F).   |
| <b>Air Leakage (Unmated)</b>                     | Less than .01 micron per cubic feet per hour on application of 15 PDS pressure differential across the connector.   |
| <b>Altitude Immersion (Mated)</b>                | After 3 cycles immersed in salt water with pressure reduced to 1 in. Hg (75,000 ft. altitude) for 30 minutes and returned to atmosphere pressure. While connectors submerged insulation resistance should remain 1000 megohms minimum and support 1500 volts RMS applied without flash-over or breakdown. |
| <b>High Potential Voltage Altitude (Unmated)</b> | When tested in accordance with MIL-STD-202, Method 301, no flash-over or breakdown under simulated altitude conditions as shown:<br><b>Altitude/Service Rating I</b><br>50,000 ..... 500 AC-RMS<br>70,000 ..... 375 AC-RMS<br>110,000 ..... 200 AC-RMS  |

\* BACC63CM supersedes BACC63BR and BACC63CN supersedes BACC63BT.

† ASD supersedes AECMA

**MIL-DTL-83723, SERIES III SQUARE FLANGE RECEPTACLE, THREADED COUPLING**

Military: **M83723/82** with Sockets, Classes G, K

Military: **M83723/83** with Pins, Classes G, K

Commercial: **BT( )-17**  
With 'O' ring seal, Classes G, K

Comm. Special for General Electric: **BJ-17**  
With Static Dynamic Seal, Stainless Steel, but not avail. in Firewall

**BJ8-17**  
Same as BJ-17 except with Scoop-proof recessed pins

**BN-17**  
Same as BJ-17 except Electro-deposited Nickel Base

**BN8-17**  
Same as BN-17 except with Scoop-proof recessed pins

**BNK-17**  
Same as BN except Stainless Steel Firewall

Special with Boeing Designation: **BACC63CN\*\***  
With 'O' ring seal, Stainless Steel Firewall, with Boeing approved contacts, Shell modifications with 360° teeth per MS3155

Comm. Special per Boeing Co. Spec.: **BSK-17**  
Stainless Steel Firewall with 'O' ring seal, qualified to Boeing, Y126 Variation - with Boeing approved contacts

Commercial ASD Designation: **EN2997 ( )0**  
Meets ASD specifications  
200°C temp. (Classes K, S, Y),  
260°C high temp. (Classes KE, SE, YE)

Comm.- Meet Several European Stds: **BT( )-17**  
With 'O' ring seal, Classes G, K  
Variations for Euro market specifications

**BJ( )-17**  
With Static Dynamic Seal, Classes G, K  
Variations for Euro market specifications



**Square Flange Receptacle Threaded**

| SERVICE CLASSES*<br>MILITARY AND COMMERCIAL |  |
|---|--|
| <b>G</b>                                    | Stainless steel, 200°C   |
| <b>K</b>                                    | Stainless steel, 200°C Firewall capability   |
| <b>S</b>                                    | Stainless steel, 200°C Firewall capability, Grounding Spring                               |
| <b>P</b>                                    | Stainless steel, 200°C, Hermetic with Eyelet contacts                                      |
| <b>Y</b>                                    | Stainless Steel, 200°C, Hermetic with Solderwell contacts                                  |
| <b>KE</b>                                   | Stainless Steel, High Temp. (260°C) Firewall capability                                    |
| <b>SE</b>                                   | Stainless steel, High Temp. (260°C) Firewall capability, Grounding Spring                  |
| <b>YE</b>                                   | Stainless Steel, High Temp. (260°C) Firewall capability, Hermetic with solderwell contacts |

\* For Classes A, R and W (aluminum shell types) - Amphenol supplies these in their Matrix 83723 family. See the preceding section of this catalog, 83723 III Matrix.



**Square Flange Receptacle, Threaded, per European Stds.**  
(Green Insert - High Temp 260°C;  
Blue insert - 200°C)

Commercial - Meet Society of British Aerospace Co./Rolls Royce Standards: **ESC10 ( )0**  
260°C Firewall (Classes KE, SE, YE), 360° accessory teeth per MS3155

**ESC11 ( )0**  
260°C Firewall (Classes KE, SE, YE), Scoop-proof recessed pins, 360° accessory teeth per MS3155

ESC10 & ESC11 also available in Hermetic square flange receptacles - See Hermetic quick ref. page XX.

ESC11 with Scoop-Proof (Recessed pins): **HTK-17**  
Standard ESC11, Class K Firewall, Scoop-proof, Variations for Euro market specifications

**HNK-17**  
Nickel finish, Class K Firewall Mating recept. has 'O' ring seal, Scoop-proof, Variations for Euro market specs

**HSK-17**  
Same as HTK, except this is a special designator for Boeing Co.

\*\* BACC63CN supersedes BACC63BT.  
See how to order pages 149-156 for complete part numbers.

Bayonet style square flange receptacles are shown on page 160.

38999  
SJT I II III

26482  
Matrix 2

83723 III  
Matrix Pyle

5015  
Crimp Rear Release Matrix

26500 Pyle

Printed  
Circuit Board

EMI Filter  
Transient

Fiber Optics

High Speed  
Contacts

Options  
Others



# MIL-DTL-83723, Series III, Pyle®

## Jam Nut Receptacle, Threaded - Quick Reference



### MIL-DTL-83723, SERIES III JAM NUT (D-HOLE MOUNT) RECEPTACLE, THREADED COUPLING

Military: **M83723/84** with Sockets, Classes G, K

Military: **M83723/85** with Pins, Classes G, K

Commercial: **BT( )-19**  
With 'O' ring seal, Classes G, K

Comm. Special for General Electric: **BJ-19**  
With Static Dynamic Seal, Stainless Steel, but not avail. in Firewall

**BJ8-19**  
Same as BJ-17 except with Scoop-proof recessed pins

**BN-19**  
Same as BJ-17 except Electro-deposited Nickel Base

**BN8-19**  
Same as BN-17 except with Scoop-proof recessed pins

**BNK-19**  
Same as BN except Stainless Steel Firewall

Commercial ASD Designation: **EN2997 ( )7**  
Meets ASD specifications  
200°C temp. (Classes K, S, Y),  
260°C high temp. (Classes KE, SE, YE)

**NFL 54143 ( )7**

Comm.- Meet Several European Stds: **BT( )-19**  
With 'O' ring seal, Classes G, K  
Variations for Euro market specifications

**BJ( )-19**  
With Static Dynamic Seal, Classes G, K  
Variations for Euro market specifications

Commercial - Meet Society of British Aerospace Co./Rolls Royce Standards: ESC10 & ESC11 jam nut receptacles are available in Hermetic only - See Hermetic quick ref. page 145



Jam Nut (D-Hole Mount) Receptacle, Threaded

### SERVICE CLASSES\* MILITARY AND COMMERCIAL

|           |  |
|-----------|--|
| <b>G</b>  | Stainless steel, 200°C   |
| <b>K</b>  | Stainless steel, 200°C Firewall capability   |
| <b>S</b>  | Stainless steel, 200°C Firewall capability, Grounding Spring                               |
| <b>P</b>  | Stainless steel, 200°C, Hermetic with Eyelet contacts                                      |
| <b>Y</b>  | Stainless Steel, 200°C, Hermetic with Solderwell contacts                                  |
| <b>KE</b> | Stainless Steel, High Temp. (260°C) Firewall capability                                    |
| <b>SE</b> | Stainless steel, High Temp. (260°C) Firewall capability, Grounding Spring                  |
| <b>YE</b> | Stainless Steel, High Temp. (260°C) Firewall capability, Hermetic with solderwell contacts |

\* For Classes A, R and W (aluminum shell types) - Amphenol supplies these in their Matrix 83723 family. See the preceding section of this catalog, 83723 III Matrix.

No Boeing Designated Jam nut receptacle.  
See how to order pages 149-156 for complete part numbers.

Bayonet style jam nut receptacles are shown on page 161.

III  
II  
I  
SJT  
38999

Matrix 2  
26482

Matrix Pyle  
83723 III

Release Matrix  
Crimp Rear  
5015

26500 Pyle

Printed  
Circuit Board

EMI Filter  
Transient

Fiber Optics

High Speed  
Contacts

Options  
Others

38999  
SJT I II III

26482  
Matrix 2

83723 III  
Matrix Pyle

5015  
Crimp Rear  
Release Matrix

26500 Pyle

Printed  
Circuit Board

EMI Filter  
Transient

Fiber Optics

High Speed  
Contacts

Options  
Others

**MIL-DTL-83723, SERIES III STANDARD STRAIGHT PLUG, THREADED COUPLING**

Military: **M83723/86** with Sockets, Classes G, K  
 Military: **M83723/87** with Pins, Classes G, K  
 Commercial: **BT( )11**  
 Mating recept. has 'O' ring seal, Classes G, K

Comm. Special for General Electric: **BJ-11**  
 With Static Dynamic Seal, Stainless Steel, but not avail. in Firewall  
**BJ8-11**  
 Same as BJ-17 except with Scoop-proof recessed pins  
**BN-11**  
 Same as BJ-17 except Electro-deposited Nickel Base  
**BN8-11**  
 Same as BN-17 except with Scoop-proof recessed pins  
**BNK-11**  
 Same as BN except Stainless Steel Firewall

No Boeing straight plug designations. No ASD or other European/ESC10 or ESC11 straight plug designations. See page 162 for Bayonet style straight plug style.

**MIL-DTL-83723, SERIES III NON-DECOUPLING PLUG (UNIQUE SELF-LOCKING CLUTCH PLATE), THREADED COUPLING**

Military: **M83723/95** with Sockets, Classes G, K  
**M83723/96** with Pins, Classes G, K  
**M83723/97** with EMI Grounding spring, with Pins  
**M83723/97** with EMI Grounding spring, with Sockets

Commercial: **BT( )12**  
 Mating recept. has 'O' ring seal, Classes G, K

Comm. Special for General Electric: **BJ-12**  
 With Static Dynamic Seal, Stainless Steel, but not avail. in Firewall  
**BJ8-12**  
 Same as BJ-17 except with Scoop-proof recessed pins  
**BN-12**  
 Same as BJ-17 except Electro-deposited Nickel Base  
**BN8-12**  
 Same as BN-17 except with Scoop-proof recessed pins  
**BNK-12**  
 Same as BN except Stainless Steel Firewall

Special with Boeing Designation: **BACC63CM\*\***  
 Mating recept. has 'O' ring seal, Stainless Steel Firewall, with Boeing approved contacts, Shell modifications with 360° teeth per MS3155

Comm. Special per Boeing Co. Spec.: **BSK-12**  
 Stainless Steel Firewall qual. to Boeing, Y126 Variation - with Boeing approved contacts

\*\* BACC63CM supersedes BACC63BR.  
 See how to order pages 149-156 for complete part numbers.  
 No Bayonet style Non-Decoupling plug available.



**Standard Straight Plug, Threaded**

**SERVICE CLASSES\* MILITARY AND COMMERCIAL**

|           |   |
|-----------|---|
| <b>G</b>  | Stainless steel, 200°C  |
| <b>K</b>  | Stainless steel, 200°C Firewall capability                                |
| <b>S</b>  | Stainless steel, 200°C Firewall capability, Grounding Spring              |
| <b>KE</b> | Stainless Steel, High Temp. (260°C) Firewall capability                   |
| <b>SE</b> | Stainless steel, High Temp. (260°C) Firewall capability, Grounding Spring |

\* For Classes A, R and W (aluminum shell types) - Amphenol supplies these in their Matrix 83723 family. See the preceding section of this catalog, 83723 III Matrix.



**Non-Decoupling Plug, Threaded**  
 Left - Green Insert - High Temp 260°C and 360° Accessory Teeth;  
 Right - Blue insert - 200°C and 3 Accessory Teeth

Commercial ASD Designation: **EN2997 ( )6**  
 Meets ASD specifications  
 200°C temp. (Classes K, S),  
 260°C high temp. (Classes KE, SE)

Comm.- Meet Several European Stds: **BT( )-12**  
 Mating recept. has 'O' ring seal, Classes G, K  
 Variations for Euro market specifications  
**BJ( )-12**  
 With Static Dynamic Seal, Classes G, K  
 Variations for Euro market specifications

Commercial - Meet Society of British Aerospace Co./Rolls  
 Royce Standards: **ESC10 ( )6**  
 260°C Firewall (Classes KE, SE),  
 360° accessory teeth per MS3155  
**ESC11 ( )6**  
 260°C Firewall (Classes KE, SE),  
 Scoop-proof, 360° accessory teeth per MS3155

ESC11 with Scoop-Proof (Recessed pins): **HTK-12**  
 Standard ESC11, Class K Firewall,  
 Scoop-proof, Variations for Euro market specs  
**HNK-12**  
 Nickel finish, Class K Firewall  
 Mating recept. has Static Dynamic seal,  
 Scoop-proof, Variations for Euro market specs  
**HSK-12**  
 Same as HTK, except this is a special designator for Boeing Co.

# MIL-DTL-83723, Series III, Pyle®

## Bayonet Plugs & Receptacles - Quick Reference

### MIL-DTL-83723, SERIES III SQUARE FLANGE RECEPTACLE, BAYONET COUPLING

Military: **M83723/71** with Sockets, Classes G, K  
 Military: **M83723/72** with Pins, Classes G, K  
 Commercial: **BY( )17**  
 With 'O' ring seal, Classes G, K



Square Flange Receptacle with Bayonet Coupling

### MIL-DTL-83723, SERIES III JAM NUT (D-HOLE MOUNT) RECEPTACLE, BAYONET COUPLING

Military: **M83723/73** with Sockets, Classes G, K  
 Military: **M83723/74** with Pins, Classes G, K  
 Commercial: **BY( )19**  
 With 'O' ring seal, Classes G, K



Jam Nut (D-Hole Mount) Receptacle with Bayonet Coupling

### MIL-DTL-83723, SERIES III STRAIGHT PLUG, BAYONET COUPLING

Military: **M83723/75** with Sockets, Classes G, K  
 Military: **M83723/76** with Pins, Classes G, K  
 Commercial: **BY( )10**  
 With 'O' ring seal, Classes G, K



Straight Plug with Bayonet Coupling

Bayonet coupling connectors are offered in Military 83723 and Commercial equivalent designations. See how to order page 149. They are not included in Boeing, GE, ASD and other European specified connectors. Shell size 28 is not available in Bayonet coupling connectors.

#### SERVICE CLASSES\* MILITARY AND COMMERCIAL

|          |  |
|----------|--|
| <b>G</b> | Stainless steel, 200°C                     |
| <b>K</b> | Stainless steel, 200°C Firewall capability |

\* For Classes A, R and W (aluminum shell types) - Amphenol supplies these in their Matrix 83723 family. See the preceding section of this catalog, 83723 III Matrix.

III  
II  
I  
SJT  
38999

Matrix 2  
26482

Matrix  
Pyle  
83723 III

Release Matrix  
Crimp Rear  
5015

26500 Pyle

Printed  
Circuit Board

EMI Filter  
Transient

Fiber Optics

High Speed  
Contacts

Options  
Others

38999  
SJT I II III

26482  
Matrix 2

83723 III  
Matrix Pyle

5015  
Crimp Rear  
Release Matrix

26500 Pyle

Printed  
Circuit Board

EMI Filter  
Transient

Fiber Optics

High Speed  
Contacts

Options  
Others

**MIL-DTL-83723, SERIES III  
HERMETIC SQUARE FLANGE RECEPTACLE,  
THREADED COUPLING**

Military: **M83723/88Y**  
Stainless Steel, Class Y,  
Solderwell contacts

Military: **M83723/88P**  
Stainless Steel, Class P,  
Eyelet contacts

Commercial: **BTY-17**  
Stainless Steel, 'O' ring Seal,  
Solderwell or Eyelet contacts,  
200°C or 260°C

**BFY-17**  
Stainless Steel, Static Dynamic  
Seal, Solderwell or Eyelet contacts,  
200°C or 260°C

**BNY-17**  
Stainless Steel, Static Dynamic  
Seal, Electro-deposited Nickel, Solderwell or Eyelet contacts,  
200°C or 260°C

Commercial  
ASD Designation: **EN2997Y0 / YE0**  
Meets ASD Specifications, Stainless Steel,  
Class Y (200°C) / Class YE (260°C), Solderwell contacts

Commercial - Meet  
Society of British  
Aerospace Co./Rolls  
Royce Standards: **ESC10YE2**  
260°C Firewall, Stainless Steel, Class YE, Solderwell contacts

**ESC11YE2**  
260°C Firewall, Stainless Steel, Class YE, Solderwell contacts,  
Scoop-proof Recessed pins



**Hermetic  
Square Flange  
Receptacle,  
Threaded**

**SERVICE CLASSES  
HERMETIC  
MILITARY AND COMMERCIAL**

|           |  |
|-----------|--|
| <b>Y</b>  | Stainless Steel, 200°C, Hermetic with solderwell contacts                                  |
| <b>P</b>  | Stainless steel, 200°C, Hermetic with eyelet contacts                                      |
| <b>YE</b> | Stainless Steel, High Temp. (260°C) Firewall capability, Hermetic with solderwell contacts |

**MIL-DTL-83723, SERIES III  
HERMETIC JAM NUT RECEPTACLE, THREADED COUPLING**

Military: **M83723/89Y**  
Stainless Steel, Class Y, Solderwell contacts

Military: **M83723/89P**  
Stainless Steel, Class Y, Eyelet contacts

Commercial: **BTY-19**  
Stainless Steel, 'O' ring Seal, Solderwell or Eyelet contacts, 200°C or 260°C

**BFY-19**  
Stainless Steel, Static Dynamic Seal, Solderwell or Eyelet contacts, 200°C or 260°C

**BNY-19**  
Stainless Steel, Static Dynamic Seal, Electro-deposited Nickel, Solderwell or Eyelet contacts, 200°C or 260°C

Commercial  
ASD Designation: **EN2997Y7 / YE7**  
Meets ASD Specifications, Stainless Steel,  
Class Y (200°C) / Class YE (260°C), Solderwell contacts

Commercial - Meet  
Society of British  
Aerospace Co./Rolls  
Royce Standards: **ESC10YE3**  
260°C Firewall, Stainless Steel, Class YE, Solderwell contacts

**ESC11YE3**  
260°C Firewall, Stainless Steel, Class YE, Solderwell contacts,  
Scoop-proof Recessed pins



**Hermetic  
Jam Nut  
Receptacle,  
Threaded**

Commercial BTY, BFY and BNY meet European specifications and General Electric spec. GEM50TF3564, Classes A & B.

Shell sizes 20, 24 and 28, consult Amphenol Aerospace for availability. Hermetic style receptacles are not included in Boeing designations.

# MIL-DTL-83723, Series III, Pyle®

## Hermetic Receptacles, cont. - Quick Reference



### MIL-DTL-83723, SERIES III HERMETIC SOLDER MOUNT/WELD MOUNT RECEPTACLE, THREADED COUPLING

**Military:** **M83723/90Y**  
Stainless Steel, Class Y, Solderwell contacts

**Military:** **M83723/90P**  
Stainless Steel, Class P, Eyelet contacts

**Commercial:** **BTY-14**  
Stainless Steel, 'O' ring Seal, Solderwell or Eyelet contacts, 200°C or 260°C

**BFY-14**  
Stainless Steel, Static Dynamic Seal, Solderwell or Eyelet contacts, 200°C or 260°C

**BNY-14**  
Stainless Steel, Static Dynamic Seal, Electro-deposited Nickel, Solderwell or Eyelet contacts, 200°C or 260°C

**Commercial**  
ASD Designation: **EN2997Y1 / YE1**  
Meets ASD Specifications, Stainless Steel, Class Y (200°C) / Class YE (260°C), Solderwell contacts

**Commercial - Meet Society of British Aerospace Co./Rolls**  
Royce Standards: **ESC10YE1**  
260°C Firewall, Stainless Steel, Class YE, Solderwell contacts

**ESC11YE1**  
260°C Firewall, Stainless Steel, Class YE, Solderwell contacts, Scoop-proof Recessed pins



Hermetic Solder Mount/Weld Mount Receptacle, Threaded

### SERVICE CLASSES HERMETIC MILITARY AND COMMERCIAL

|           |  |
|-----------|--|
| <b>Y</b>  | Stainless Steel, 200°C, Hermetic with solderwell contacts                                  |
| <b>P</b>  | Stainless steel, 200°C, Hermetic with eyelet contacts                                      |
| <b>YE</b> | Stainless Steel, High Temp. (260°C) Firewall capability, Hermetic with solderwell contacts |

Commercial BTY, BFY and BNY meet European specifications and General Electric spec. GEM50TF3564, Classes A & B.

Shell sizes 20, 24 and 28, consult Amphenol Aerospace for availability. Hermetic style receptacles are not included in Boeing designations.

III  
II  
I  
SJT  
38999

Matrix 2  
26482

Matrix  
Pyle  
83723 III

Release Matrix  
Crimp Rear  
5015

26500 Pyle

Printed  
Circuit Board

EMI Filter  
Transient

Fiber Optics

High Speed  
Contacts

Options  
Others



**INSERT ARRANGEMENTS**

| Shell Size/<br>Insert<br>Arrangement | Service<br>Rating | Total<br>Contacts | Contact Size |    |    |    |
|--------------------------------------|-------------------|-------------------|--------------|----|----|----|
|                                      |                   |                   | 8            | 12 | 16 | 20 |
| 08-03                                | I                 | 3                 |              |    |    | 3  |
| 08-98                                | I                 | 3                 |              |    |    | 3  |
| 10-02**                              | I                 | 2                 |              |    |    | 2  |
| 10-05                                | I                 | 5                 |              |    |    | 5  |
| 10-06                                | I                 | 6                 |              |    |    | 6  |
| 10-20                                | I                 | 2                 |              |    | 2  |    |
| 12-03***                             | I                 | 3                 |              |    | 3  |    |
| 12-12                                | I                 | 12                |              |    |    | 12 |
| 14-04***                             | I                 | 4                 |              | 4  |    |    |
| 14-07***                             | I                 | 7                 |              |    | 7  |    |
| 14-12                                | I                 | 12                |              |    | 3  | 9  |
| 14-15                                | I                 | 15                |              |    |    | 15 |
| 16-10***                             | I                 | 10                |              |    | 10 |    |
| 16-24                                | I                 | 24                |              |    |    | 24 |
| 18-08                                | I                 | 8                 |              | 8  |    |    |
| 18-14***                             | I                 | 14                |              |    | 14 |    |
| 18-31                                | I                 | 31                |              |    |    | 31 |
| 20-16***                             | I                 | 16                |              |    | 16 |    |
| 20-25                                | I                 | 25                |              | 6  |    | 19 |
| 20-28**                              | I                 | 28                |              | 4  |    | 24 |
| 20-39                                | I                 | 39                |              |    | 2  | 37 |
| 20-41                                | I                 | 41                |              |    |    | 41 |
| 22-12**                              | I                 | 12                |              | 12 |    |    |
| 22-19***                             | I                 | 19                |              |    | 19 |    |
| 22-27                                | I                 | 27                |              |    | 27 |    |
| 22-32**                              | I                 | 32                |              | 6  |    | 26 |
| 22-39**                              | I                 | 39                |              |    | 12 | 27 |
| 22-55                                | I                 | 55                |              |    |    | 55 |
| 24-19†♦                              | I                 | 19                |              | 19 |    |    |
| 24-30†***                            | I                 | 30                |              |    | 30 |    |
| 24-43**                              | I                 | 43                |              |    | 20 | 23 |
| 24-46†♦♦                             | I                 | 46                | 2 Twinax     |    | 4  | 40 |
| 24-57                                | I                 | 57                |              | 2  |    | 55 |
| 24-61                                | I                 | 61                |              |    |    | 61 |
| 28-41†                               | I                 | 41                |              |    | 41 |    |
| 28-42†***                            | I                 | 42                |              |    | 42 |    |
| 28-91†*                              | I                 | 91                |              |    |    | 91 |

- † Not an MS layout.
- \* Special - consult Amphenol for availability.
- \*\* Special Pyle with Matrix 83723 insert (ESC10 type, EN2997 Spec); consult Amphenol for availability.
- \*\*\*Boeing Qualified Arrangements (See Boeing How to Order page 151)
- ♦ 24-19 is a special ground plane insert with purchased size 12 Coax contacts; consult Amphenol for information.
- ♦♦ 24-46 is a special insert that accommodates size 8 twinax contacts with ground spring.
- Size 8 and Size 12 cavities can accommodate Twinax or Coax contacts; consult Amphenol for information.
- Sizes 20, 24 and 28 Hermetic; consult Amphenol for availability.
- Size 28 not available in Bayonet style.

**ALTERNATE KEYING POSITIONS  
(Rotation of key/keyway of shell)**

To avoid cross-plugging problems in applications requiring the use of more than one connector of the same size and arrangement, alternate keying positions are available as indicated in the chart below. The diagram shows the engaging view of a receptacle shell with keyways. The insert is rotated counter-clockwise relative to the center-line. Plug shells would be the opposite of this diagram.

In the "Normal insert position" (position N), the insert center line coincides with the center-line of the master key/keyway of the shell. In the "alternate keying positions" (positions 6, 7, 8, 9 and Y), the minor keys/keyways are positioned with reference to master key/keyway as indicated in the keying position table.

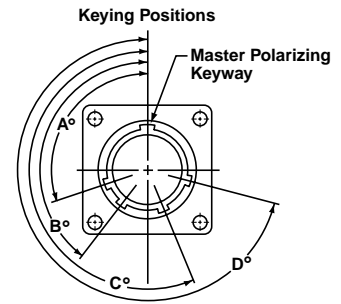

Shown is Engaging Face View of Receptacle Shell with Keyways (Plug Shell Keys would be Opposite)

**ALTERNATE KEYING POSITIONS OF SHELL**

| Shell Size                        | Polarizing Position | Key/Keyway Positions |     |     |     |
|-----------------------------------|---------------------|----------------------|-----|-----|-----|
|                                   |                     | A°                   | B°  | C°  | D°  |
| 8 thru 24                         | N                   | 105                  | 140 | 215 | 265 |
|                                   | 6                   | 102                  | 132 | 248 | 320 |
| 8 & 10                            | 7                   | 80                   | 118 | 230 | 312 |
|                                   | 8                   | 35                   | 140 | 205 | 275 |
|                                   | 9                   | 64                   | 155 | 234 | 304 |
|                                   | Y††                 | 25                   | 115 | 220 | 270 |
| 12, 14, 16, 18, 20, 22, 24 and 28 | 6                   | 18                   | 149 | 192 | 259 |
|                                   | 7                   | 92                   | 152 | 222 | 342 |
|                                   | 8                   | 84                   | 152 | 204 | 334 |
|                                   | 9                   | 24                   | 135 | 199 | 240 |
|                                   | Y††                 | 98                   | 152 | 268 | 338 |

**ESC 11 (HTK SERIES) ONLY**

| Shell Size | Polarizing Position | Key/Keyway Positions |     |     |     |
|------------|---------------------|----------------------|-----|-----|-----|
|            |                     | A°                   | B°  | C°  | D°  |
| 14 thru 24 | N                   | 95                   | 145 | 220 | 255 |
|            | 6                   | 101                  | 168 | 211 | 342 |
|            | 7                   | 18                   | 138 | 208 | 268 |
|            | 8                   | 26                   | 156 | 208 | 276 |
|            | 9                   | 120                  | 161 | 225 | 336 |

†† Position Y supersedes inactive positions 10 and Z designations. Ref. MIL-STD-1554.

For ordering information on accessories, such as protection caps and backshell hardware, contact Amphenol Aerospace, Sidney, NY.

# MIL-DTL-83723, Series III, Pyle®

## Insert Arrangements



front face of pin insert or rear face of socket insert illustrated

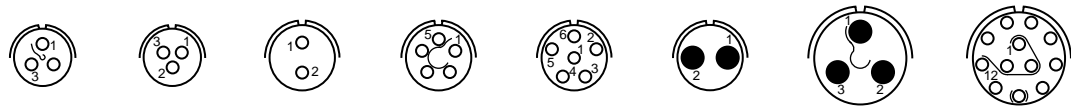

| Insert Arrangement | 08-03 | 08-98 | 10-02** | 10-05 | 10-06 | 10-20 | 12-03*** | 12-12 |
|--------------------|-------|-------|---------|-------|-------|-------|----------|-------|
| Service Rating     | I     | I     | I       | I     | I     | I     | I        | I     |
| Number of Contacts | 3     | 3     | 2       | 5     | 6     | 2     | 3        | 12    |
| Contact Size       | 20    | 20    | 20      | 20    | 20    | 16    | 16       | 20    |

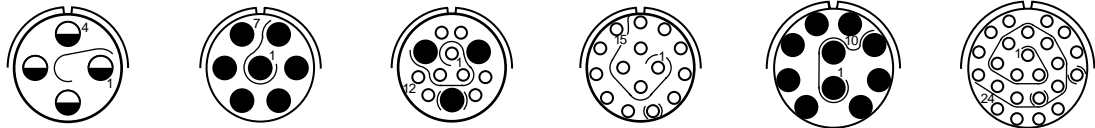

| Insert Arrangement | 14-04*** | 14-07*** | 14-12 |    | 14-15 | 16-10*** | 16-24 |
|--------------------|----------|----------|-------|----|-------|----------|-------|
| Service Rating     | I        | I        | I     | I  | I     | I        | I     |
| Number of Contacts | 4        | 7        | 9     | 3  | 15    | 10       | 24    |
| Contact Size       | 12       | 16       | 20    | 16 | 20    | 16       | 20    |

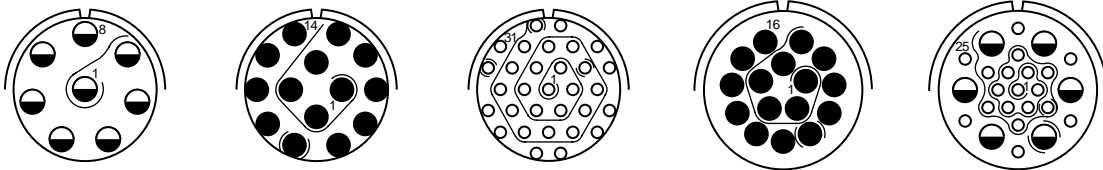

| Insert Arrangement | 18-08 | 18-14*** | 18-31 | 20-16*** | 20-25 |
|--------------------|-------|----------|-------|----------|-------|
| Service Rating     | I     | I        | I     | I        | I     |
| Number of Contacts | 8     | 14       | 31    | 16       | 19 6  |
| Contact Size       | 12    | 16       | 20    | 16       | 20 12 |

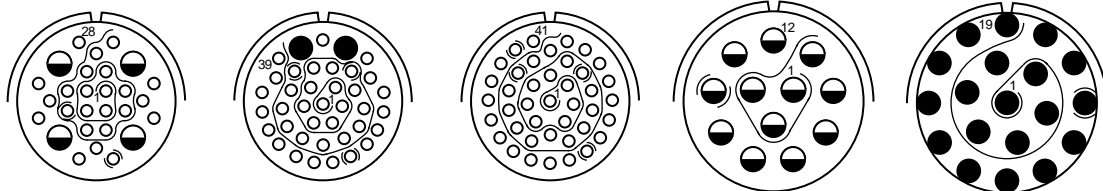

| Insert Arrangement | 20-28** |    | 20-39 |    | 20-41 | 22-12** | 22-19*** |
|--------------------|---------|----|-------|----|-------|---------|----------|
| Service Rating     | I       | I  | I     | I  | I     | I       | I        |
| Number of Contacts | 24      | 4  | 37    | 2  | 41    | 12      | 19       |
| Contact Size       | 20      | 12 | 20    | 16 | 20    | 12      | 16       |

† Not an MS layout.  
 \* Special - consult Amphenol for availability.  
 \*\* Special Pyle with Matrix 83723 insert (ESC10 type, EN2997 Spec); consult Amphenol for availability.  
 \*\*\*Boeing Qualified Arrangements (See Boeing How to Order page 151)  
 Size 8 and Size 12 cavities can accommodate Twinax or Coax contacts; consult Amphenol for information.  
 Sizes 20, 24 and 28 Hermetic; consult Amphenol for availability.  
 Size 28 not available in Bayonet style.

**CONTACT LEGEND**

20 16 12 8

III 38999  
 II 26482 Matrix 2  
 I 83723 III Matrix Pyle  
 SJT 5015 Crimp Rear Release Matrix  
 26500 Pyle  
 Printed Circuit Board  
 EMI Filter Transient  
 Fiber Optics  
 High Speed Contacts  
 Options Others

front face of pin insert or rear face of socket insert illustrated

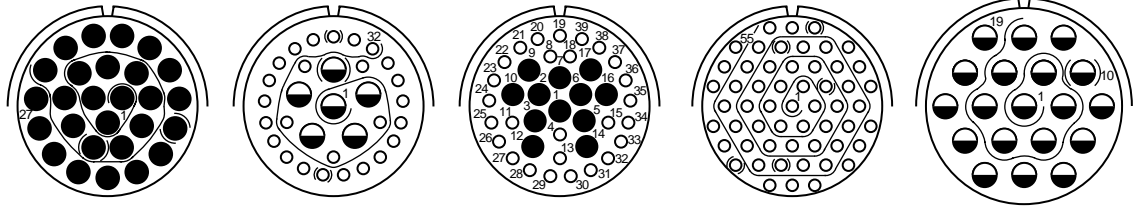

| Insert Arrangement | 22-27 | 22-32** |    | 22-39** |    | 22-55 | 24-19† |
|--------------------|-------|---------|----|---------|----|-------|--------|
| Service Rating     | I     | I       |    | I       |    | I     | I      |
| Number of Contacts | 27    | 26      | 6  | 27      | 12 | 55    | 19     |
| Contact Size       | 16    | 20      | 12 | 20      | 16 | 20    | 12     |

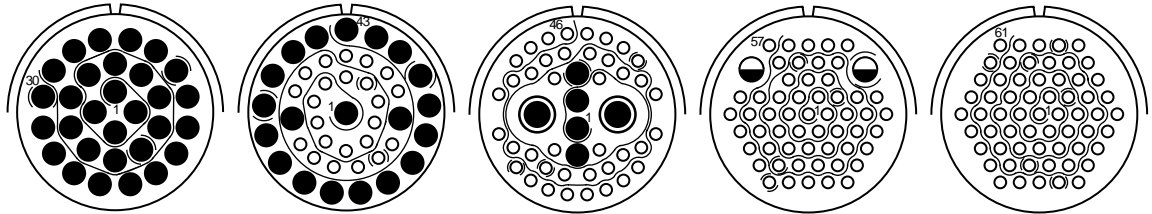

| Insert Arrangement | 24-30†*** | 24-43** |    | 24-46†♦♦ |    |             | 24-57 | 24-61 |    |
|--------------------|-----------|---------|----|----------|----|-------------|-------|-------|----|
| Service Rating     | I         | I       |    | I        |    |             | I     | I     |    |
| Number of Contacts | 30        | 23      | 20 | 40       | 4  | 2           | 55    | 2     | 61 |
| Contact Size       | 16        | 20      | 16 | 20       | 16 | 8<br>Twinax | 20    | 12    | 20 |

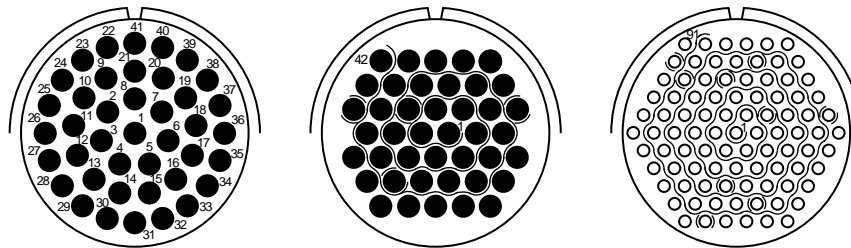

| Insert Arrangement | 28-41† | 28-42†*** | 28-91†* |
|--------------------|--------|-----------|---------|
| Service Rating     | I      | I         | I       |
| Number of Contacts | 41     | 42        | 91      |
| Contact Size       | 16     | 16        | 20      |

† Not an MS layout.

\* Special - consult Amphenol for availability.

\*\* Special Pyle with Matrix 83723 insert (ESC10 type, EN2997 Spec); consult Amphenol for availability.

\*\*\*Boeing Qualified Arrangements (See Boeing How to Order page 151)

♦ 24-19 is a special ground plane insert with purchased size 12 Coax contacts; consult Amphenol for information.

♦♦ 24-46 is a special insert that accommodates size 8 twinax contacts with ground spring.

Size 8 and Size 12 cavities can accommodate Twinax or Coax contacts; consult Amphenol for information.

Sizes 20, 24 and 28 Hermetic; consult Amphenol for availability.

Size 28 not available in Bayonet style.

CONTACT LEGEND

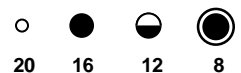

# MIL-DTL-83723, Series III, Pyle®

## How to Order – Military or Commercial Designation



|                           | 1.             | 2.                                       | 3.            | 4.                             | 5.                                 |
|---------------------------|----------------|--|---------------|--------------------------------|------------------------------------|
| MIL-DTL-83723, Series III | Connector Type | Connector Style and Contact Type (Crimp) | Service Class | Shell Size/ Insert Arrangement | Alternate Keying Position of Shell |
| <b>MILITARY</b>           | <b>M83723</b>  | <b>/82</b>                               | <b>G</b>      | <b>16-24</b>                   | <b>6</b>                           |

|   | 1.              | 2.            | 3.          | 4.                             | 5.           | 6.   | 7.                                 | 8.         |
|---|-----------------|---------------|-------------|--------------------------------|--------------|--|------------------------------------|------------|
| Amphenol® Pyle® MIL-DTL-83723, Series III | Connector Style | Service Class | Shell Style | Shell Size/ Insert Arrangement | Contact Type | Alternate Contact Finish or Without Contacts | Alternate Keying Position of Shell | Variations |
| <b>COMMERCIAL</b>                         | <b>BT</b>       | <b>G</b>      | <b>-17</b>  | <b>16-24</b>                   | <b>S</b>     | <b>D</b>                                     | <b>06</b>                          | <b>XXX</b> |

### Step 1. Military Connector Type

|               |   |
|---------------|---|
| <b>M83723</b> | <b>Designates MIL-DTL-83723 Series III Connectors</b> |
|---------------|---|

### Step 2. Select a Connector Style

(Refer to military specification slash sheet number).  
(How to Order Hermetic Styles is provided on page 156).

|            | Designates   |
|------------|--|
| <b>/71</b> | Bayonet, Square Flange Receptacle, with sockets                        |
| <b>/72</b> | Bayonet, Square Flange Receptacle, with pins                           |
| <b>/73</b> | Bayonet, Jam Nut (D-Hole Mount) Recept., with sockets                  |
| <b>/74</b> | Bayonet, Jam Nut (D-Hole Mount) Recept., with pins                     |
| <b>/75</b> | Bayonet, Straight Plug, with sockets                                   |
| <b>/76</b> | Bayonet, Straight Plug, with pins                                      |
| <b>/82</b> | Threaded, Square Flange Receptacle, with sockets                       |
| <b>/83</b> | Threaded, Square Flange Receptacle, with pins                          |
| <b>/84</b> | Threaded, Jam Nut (D-Hole Mount) Recept., with sockets                 |
| <b>/85</b> | Threaded, Jam Nut (D-Hole Mount) Recept., with pins                    |
| <b>/86</b> | Threaded, Straight Plug, with sockets                                  |
| <b>/87</b> | Threaded, Straight Plug, with pins                                     |
| <b>/95</b> | Threaded, Non-Decoupling Plug, with sockets                            |
| <b>/96</b> | Threaded, Non-Decoupling Plug, with pins                               |
| <b>/97</b> | Threaded, Non-Decoupling Plug, with EMI Grounding spring, with sockets |
| <b>/98</b> | Threaded, Non-Decoupling Plug, with EMI Grounding spring, with pins    |

### Step 3. Select a Service Class

|          | Designates               |
|----------|--------------------------|
| <b>G</b> | Stainless Steel          |
| <b>K</b> | Stainless Steel Firewall |

Note: See Matrix 83723 styles for aluminum classes A, R and W.

### Step 4. Select a Shell Size & Insert Arrangement from chart on pg. 146. (except size 28 is not available in Bayonet Style)

Shell Size & Insert Arrangements are on page 146. First number represents Shell Size, second number is the Insert Arrangement

### Step 5. Select an Alternate Keying Position - Rotation of master key/keyway of shell.

Use N for normal. Use 6, 7, 8, 9 or Y for alternate keying positions. See page 146 for descriptions.

### Step 1. Select a Commercial Connector Style Designed to be Equivalent to M83723, Series III

|           | Designates                                |
|-----------|---|
| <b>BT</b> | Threaded with 'O' ring seal in receptacle |
| <b>BY</b> | Bayonet with 'O' ring seal in receptacle  |

(How to Order Hermetic Styles is provided on page 156).

### Step 2. Select a Service Class

|          | Designates               |
|----------|--------------------------|
| <b>G</b> | Stainless steel          |
| <b>K</b> | Stainless steel Firewall |

Note: See Matrix 83723 styles for aluminum classes A, R and W.

### Step 3. Select a Shell Style

|            | Designates                                  |
|------------|---|
| <b>-10</b> | Straight Plug, Bayonet coupling only        |
| <b>-11</b> | Straight Plug, Threaded coupling only       |
| <b>-12</b> | Non-Decoupling Plug, Threaded coupling only |
| <b>-17</b> | Square Flange Receptacle                    |
| <b>-19</b> | Jam Nut (D-Hole Mount) Receptacle           |

### Step 4. Select a Shell Size & Insert Arrangement from chart on pg. 146. (except size 28 is not available in Bayonet Style)

Shell Size & Insert Arrangements are on page 146. First number represents Shell Size, second number is the Insert Arrangement.

### Step 5. Select a Contact Type (Crimp)

|          | Designates      |
|----------|-----------------|
| <b>P</b> | Pin Contacts    |
| <b>S</b> | Socket Contacts |

### Step 6. Alternate Contact Finish or without Contacts

|          | Designates            |
|----------|-----------------------|
| <b>D</b> | Gold per SAE AS39029* |
| <b>E</b> | Without contacts      |

### Step 7. Select an Alternate Keying Position - Rotation of master key/keyway of shell.

Use N for normal. Use 06, 07, 08, 09 or Y for alternate keying positions. See page 146 for descriptions.

### Step 8. Variations

Consult Amphenol Aerospace, Sidney, NY for information.

\*supersedes MIL-C-39029

III  
II  
I  
SJT  
38999

Matrix 2  
26482

Matrix  
Pyle  
83723 III

Crimp Rear  
Release Matrix  
5015

26500 Pyle

Printed  
Circuit Board

EMI Filter  
Transient

Fiber Optics

High Speed  
Contacts

Options  
Others

38999  
SJT I II III

26482  
Matrix 2

83723 III  
Matrix Pyle

5015  
Crimp Rear  
Release Matrix

26500 Pyle

Printed  
Circuit Board

EMI Filter  
Transient

Fiber Optics

High Speed  
Contacts

Options  
Others

Amphenol® Pyle®  
MIL-DTL-83723, Series III  
**PYLE COMMERCIAL  
DESIGNED TO MEET  
G. E. SPECIFICATIONS**

| 1.             | 2.          | 3.                                   | 4.                             | 5.           | 6.   | 7.                                 | 8.         |
|----------------|-------------|--------------------------------------|--------------------------------|--------------|--|------------------------------------|------------|
| Connector Type | Shell Style | Shell Modification (Accessory Teeth) | Shell Size/ Insert Arrangement | Contact Type | Alternate Contact Finish or Without Contacts | Alternate Keying Position of Shell | Variations |
| BJ             | -17         | E                                    | 16-24                          | S            | D  | 06                                 | XXXX       |

**Step 1. Select a Commercial Connector Type  
Designed to Meet General Electric Specifications**

|            | Designates   |
|------------|--|
| <b>BJ</b>  | Threaded, Stainless Steel, Static/Dynamic Seal in receptacle |
| <b>BJ8</b> | Same as BJ except with Scoop-Proof Recessed pins             |
| <b>BN</b>  | Same as BJ except Electro-deposited Nickel Plated            |
| <b>BN8</b> | Same as BN except with Scoop-Proof Recessed pins             |
| <b>BNK</b> | Same as BN except Stainless Steel Firewall                   |

**Step 2. Select a Shell Style**

|            | Designates                        |
|------------|-----------------------------------|
| <b>-10</b> | Bayonet Plug                      |
| <b>-11</b> | Threaded Straight Plug            |
| <b>-12</b> | Threaded Non-Decoupling Plug      |
| <b>-17</b> | Square Flange Receptacle          |
| <b>-19</b> | Jam Nut (D-Hole Mount) Receptacle |

**Step 3. Select a Shell Modification**

|          | Designates   |
|----------|--|
| <b>E</b> | 360° Accessory Teeth per MS3155 Plug and Receptacle                |
| <b>F</b> | 360° Accessory Teeth per MS3155, EMI Grounding Spring on Plug only |
| <b>G</b> | 3 Accessory Teeth, EMI Grounding Spring on Plug only               |

**Step 4. Select a Shell Size & Insert  
Arrangement from chart on pg. 146.**

Shell Size & Insert Arrangements are on page 146. First number represents Shell Size, second number is the Insert Arrangement.

**Step 5. Select a Contact Type (Crimp)**

|          | Designates                     |
|----------|--------------------------------|
| <b>P</b> | Pin Contacts                   |
| <b>K</b> | #20 Pins with #18 crimpwell    |
| <b>S</b> | Socket Contacts                |
| <b>L</b> | #20 Sockets with #18 crimpwell |

**Step 6. Alternate Contact Finish or without  
Contacts**

|          | Designates            |
|----------|-----------------------|
| <b>D</b> | Gold per SAE AS39029* |
| <b>E</b> | Without contacts      |

**Step 7. Select an Alternate Keying Position -  
Rotation of master key/keyway of shell.**

Use N for normal. Use 06, 07, 08, 09 or Y for alternate keying positions. See page 146 for descriptions.

**Step 8. Variations (Primarily Designed for  
General Electric)**

|             | Designates   |
|-------------|--|
| <b>Y176</b> | 260°C per G.E. M50TF3564, Class B, No Accessory Teeth                    |
| <b>Y185</b> | Older style with 200°C Capability - European market (Superseded by Y163) |
| <b>Y186</b> | 260°C Capability per G. E. M50TF3564 Class B**                           |
| <b>Y188</b> | 200°C Capability per G. E. M50TF3564 Class A**                           |

Another variation available with molding groove for potting - consult Amphenol Aerospace for ordering information.

\* supersedes MIL-C-39029

\*\* Also see Hermetic styles that meet G.E. specification M50TF3564, Classes A & B on page 156.



# MIL-DTL-83723, Series III, Pyle®



## How to Order – Boeing Designation (BACC63CM/CN\*)

### or Pyle Commercial Equivalent

|                               | 1.             | 2.          | 3.                                | 4.                                   | 5.  | 6.            | 7.                                 | 8.                   |
|-------------------------------|----------------|-------------|-----------------------------------|--------------------------------------|---|---------------|------------------------------------|----------------------|
| MIL-DTL-83723, Series III     | Connector Type | Shell Style | Boeing Spec. Qualified Shell Size | Shell Modification (Accessory Teeth) | Boeing Spec. Qualified Insert Arrangement | Contact Style | Alternate Keying Position of Shell | With Contacts Option |
| <b>BOEING CO. DESIGNATION</b> | BACC63         | CM          | 18                                | B                                    | 14  | P             | 8                                  | A                    |

|   | 1.             | 3.          | 4.                                   | 5.                             | 6.           | 7.   | 8.                                 |           |
|---|----------------|-------------|--------------------------------------|--------------------------------|--------------|--|------------------------------------|-----------|
| Amphenol® Pyle® MIL-DTL-83723, Series III           | Connector Type | Shell Style | Shell Modification (Accessory Teeth) | Shell Size/ Insert Arrangement | Contact Type | Alternate Contact Finish or Without Contacts | Alternate Keying Position of Shell | Variation |
| <b>PYLE COMMERCIAL EQUIV. TO BOEING BACC63CM/CN</b> | BSK            | -12         | E                                    | 18-14                          | P            | D  | 08                                 | XXX       |

### Step 1. Boeing Co. Designation

|               |  |
|---------------|--|
| <b>BACC63</b> | Designates MIL-DTL-83723 Series III Boeing Designation BACC63CM/CN** Firewall Connectors |
|---------------|--|

(Refer to military specification slash sheet number.)

\*\* BACC63CM/CN supersedes BACC63BR/BT

### Step 2. Select a Connector Type

|           | Designates   |
|-----------|--|
| <b>CM</b> | Threaded, Non-Decoupling Plug Stainless Steel Firewall       |
| <b>CN</b> | Threaded, Square Flange Receptacle, Stainless Steel Firewall |

### Step 3. Select a Boeing Specification Qualified Shell Size

12, 14, 16, 18, 20, 22, 24, 28

### Step 4. Select a Shell Modification

|          | Designates   |
|----------|--|
| <b>-</b> | Accessory Teeth per MIL-DTL-83723, Series III (normally 3 teeth)   |
| <b>B</b> | 360° Accessory Teeth per MS3155 Plug and Receptacle                |
| <b>D</b> | 360° Accessory Teeth per MS3155, EMI Grounding Spring on Plug only |

### Step 5. Select a Boeing Specification Qualified Insert Arrangement

12-03, 14-04, 14-07, 16-10, 18-14, 20-16, 22-19, 24-30, 28-42 (these incorporate Boeing approved contacts)

### Step 6. Select a Contact Type (Crimp)

|          | Designates                                   |
|----------|--|
| <b>P</b> | Pin Contacts, Gold plate per SAE AS39029*    |
| <b>S</b> | Socket Contacts, Gold plate per SAE AS39029* |

### Step 7. Select an Alternate Keying Position - Rotation of master key/keyway of shell.

Use N for normal. Use 6, 7, 8, 9 or Y for alternate keying positions. See page 146 for descriptions.

### Step 8. With Contacts Option

|          | Designates  |
|----------|---|
| <b>A</b> | With Contacts and Sealing Plugs (Letter 'A' to be used on purchase orders only, and will not appear on connector as part of connector part number.) |
|          | Leave blank without contacts and sealing plugs  |

\*supersedes MIL-C-39029

### Step 1. Commercial Connector Type Designed to be Equivalent to Boeing BACC63

|            | Designates                                |
|------------|---|
| <b>BSK</b> | Threaded with 'O' ring seal in receptacle |

### Step 2. Select a Shell Style

|            | Designates   |
|------------|--|
| <b>-12</b> | Threaded, Non-Decoupling Plug Stainless Steel Firewall       |
| <b>-17</b> | Threaded, Square Flange Receptacle, Stainless Steel Firewall |

### Step 3. Select a Shell Modification

No designation needed for shells with accessory teeth per MIL-DTL-83723, Series III (normally 3 teeth).

|          | Designates   |
|----------|--|
| <b>E</b> | 360° Accessory Teeth per MS3155 Plug and Receptacle                |
| <b>F</b> | 360° Accessory Teeth per MS3155, EMI Grounding Spring on Plug only |

### Step 4. Select a Shell Size & Insert Arrangement from chart on pg. 146.

Shell Sizes 12, 14, 18, 20, 24, 28 are available. Insert Arrangements for these size shells are given on page 146. Shell size and insert arrangement are written together. First number represents Shell Size, second number is the Insert Arrangement.

### Step 5. Select a Contact Type (Crimp)

|          | Designates      |
|----------|-----------------|
| <b>P</b> | Pin Contacts    |
| <b>S</b> | Socket Contacts |

### Step 6. Alternate Contact Finish or without Contacts

|          | Designates                         |
|----------|------------------------------------|
| <b>D</b> | Gold per SAE AS39029*              |
| <b>E</b> | Without contacts and sealing plugs |

### Step 7. Select an Alternate Keying Position - Rotation of master key/keyway of shell.

Omit for N for normal. Use 06, 07, 08, 09 or Y for alternate keying positions. See page 146 for descriptions.

### Step 8. Variation

|             | Designates  |
|-------------|---|
| <b>Y126</b> | Contact Marking per MIL-DTL-83723/33 & /34 (Required with BACC63CM/CN Series) |

No variation suffix - connector will incorporate Mil-Spec AS39020 contacts

III  
II  
I  
SJT  
38999

Matrix 2  
26482

Matrix Pyle  
83723 III

Crimp Rear Release Matrix  
5015

26500 Pyle

Printed Circuit Board

EMI Filter Transient

Fiber Optics

High Speed Contacts

Options Others

38999  
SJT I II III

26482  
Matrix 2

83723 III  
Matrix Pyle

5015  
Crimp Rear  
Release Matrix

26500 Pyle

Printed  
Circuit Board

EMI Filter  
Transient

Fiber Optics

High Speed  
Contacts

Options  
Others

| MIL-DTL-83723,<br>Series III<br>ASD DESIGNATION | 1.<br>Connector<br>Type | 2.<br>Service<br>Class | 3.<br>Shell<br>Style | 4.<br>Shell Size/Insert<br>Arrangement | 5.<br>Contact<br>Style | 6.<br>Alternate Keying<br>Position of Shell |
|---|-------------------------|------------------------|----------------------|--|------------------------|---|
|   | EN2997                  | KE                     | 6                    | 16-24                                  | F                      | 6   |

**Step 1. Select an ASD Designated/European Standards Connector Type**

|        | Designates      |
|--------|-----------------|
| EN2997 | ASD Designation |

Note: ASD supersedes AECMA Designation

**Step 2. Select a Service Class**

|           | Designates Standard Temperature Class                          |
|-----------|--|
| <b>K</b>  | Threaded, Stainless Steel, 200°C                               |
| <b>S</b>  | Threaded, Stainless Steel, EMI Grounding Spring on Plug, 200°C |
| <b>Y</b>  | Stainless Steel Hermetic with Solderwell Contacts, 200°C       |
|           | Designates High Temperature Class                              |
| <b>KE</b> | Threaded, Stainless Steel Firewall, 260°C                      |
| <b>SE</b> | Threaded, Stainless Steel, EMI Grounding Spring on Plug, 260°C |
| <b>YE</b> | Stainless Steel Hermetic with Solderwell Contacts, 260°C       |

**Step 3. Select a Shell Style**

|          | Designates                                       |
|----------|--|
| <b>0</b> | Threaded, Square Flange Receptacle               |
| <b>1</b> | Threaded, Solder Mount Receptacle, Hermetic only |
| <b>6</b> | Threaded Non-Decoupling Plug                     |
| <b>7</b> | Threaded Jam Nut (D-Hole Mount) Receptacle       |

**Step 4. Select a Shell Size & Insert Arrangement from chart on pg. 146.**

Shell Size & Insert Arrangements are on page 146. First number represents Shell Size, second number is the Insert Arrangement.

**Step 5. Select a Contact Type (Crimp)**

|          | Designates                     |
|----------|--------------------------------|
| <b>M</b> | Standard Pin Contacts          |
| <b>C</b> | #20 Pins with #18 crimpwell    |
| <b>A</b> | Pin Insert less Contacts       |
| <b>F</b> | Standard Socket Contacts       |
| <b>D</b> | #20 Sockets with #18 crimpwell |
| <b>B</b> | Socket Insert less Contacts    |

**Step 6. Select an Alternate Keying Position - Rotation of master key/keyway of shell.**

Use N for normal. Use 6, 7, 8, 9 or Y for alternate keying positions. See page 146 for descriptions.

|  | 1.             | 2.            | 3.          | 4.                                   | 5.                             | 6.           | 7.   | 8.                             | 9.         |
|--|----------------|---------------|-------------|--------------------------------------|--------------------------------|--------------|--|--------------------------------|------------|
|  | Connector Type | Service Class | Shell Style | Shell Modification (Accessory Teeth) | Shell Size/ Insert Arrangement | Contact Type | Alternate Contact Finish or Without Contacts | Alternate Keying Pos. of Shell | Variations |
| <b>Amphenol® Pyle® MIL-DTL-83723, Series III</b><br><b>PYLE COMMERCIAL DESIGNED TO MEET ASD &amp; EUROPEAN STDS.</b> | BT             | G             | -12         | E                                    | 18-14                          | P            | D  | 08                             | XXX        |

#### Step 1. Select a Commercial Connector Type Designed to Meet ASD/European Standards

|    | Designates   |
|----|--|
| BT | Threaded with 'O' ring seal in receptacle                    |
| BJ | Threaded, Stainless Steel, Static/Dynamic Seal in receptacle |

#### Step 2. Select a Service Class

|   | Designates               |
|---|--------------------------|
| G | Stainless steel          |
| K | Stainless steel Firewall |

#### Step 3. Select a Shell Style

|     | Designates                                  |
|-----|---|
| -12 | Threaded, Non-Decoupling Plug               |
| -17 | Threaded, Square Flange Receptacle          |
| -19 | Threaded, Jam Nut (D-Hole Mount) Receptacle |

#### Step 4. Select a Shell Modification

No designation needed for shells with accessory teeth per MIL-DTL-83723, Series III (normally 3 teeth).

|   | Designates   |
|---|--|
| E | 360° Accessory Teeth per MS3155 Plug and Receptacle                |
| F | 360° Accessory Teeth per MS3155, EMI Grounding Spring on Plug only |

#### Step 5. Select a Shell Size & Insert Arrangement from chart on pg. 146.

Shell Size & Insert Arrangements are on page 146. First number represents Shell Size, second number is the Insert Arrangement.

#### Step 6. Select a Contact Type (Crimp)

|   | Designates      |
|---|-----------------|
| P | Pin Contacts    |
| S | Socket Contacts |

#### Step 7. Alt. Contact Finish or without Contacts

|   | Designates            |
|---|-----------------------|
| D | Gold per SAE AS39029* |
| E | Without contacts      |

#### Step 8. Select an Alternate Keying Position - Rotation of master key/keyway of shell.

Use N for normal. Use 06, 07, 08, 09 or Y for alternate keying positions. See page 146 for descriptions.

#### Step 9. Variations (Designed for Meeting European Specifications)

|      | Designates                           |
|------|--------------------------------------|
| Y144 | 260°C Capability (Euro Market)       |
| Y163 | 200°C Capability (Euro Market)       |
| Y175 | Older designation superseded by Y144 |

\*supersedes MIL-C-39029

III  
II  
I  
SJT  
38999

Matrix 2  
26482

Matrix  
Pyle  
83723 III

Crimp Rear  
Release Matrix  
5015

26500 Pyle

Printed  
Circuit Board

EMI Filter  
Transient

Fiber Optics

High Speed  
Contacts

Options  
Others

| 1.             | 2.            | 3.          | 4.                             | 5.           | 6.                                 | 7.         |
|----------------|---------------|-------------|--------------------------------|--------------|------------------------------------|------------|
| Connector Type | Service Class | Shell Style | Shell Size/ Insert Arrangement | Contact Type | Alternate Keying Position of Shell | Variations |
| ESC10          | KE            | 0           | 16-24                          | S            | 6                                  | X          |

MIL-DTL-83723,  
Series III  
MEETS SOCIETY OF BRITISH  
AEROSPACE CO./  
ROLLS ROYCE STANDARDS

**Step 1.** Select a Connector Type that Meets European Specifications for Society of British Aerospace Co./Rolls Royce Standards

|       | Designates  |
|-------|---|
| ESC10 | Threaded, Basic High Temperature Connector, 260°C Firewall                                |
| ESC11 | Threaded, High Temperature Connector (260°C Firewall) with 100% Scoop-Proof Recessed Pins |

**Step 2.** Select a Service Class

|    | Designates High Temperature Class                                  |
|----|--|
| KE | Threaded, Stainless Steel Firewall, 260°C                          |
| SE | Threaded, Stainless Steel, EMI Grounding Spring on Plug, 260°C     |
| YE | Threaded, Stainless Steel Hermetic with Solderwell Contacts, 260°C |

**Step 3.** Select a Shell Style

|   | Designates  |
|---|---|
| 0 | Threaded, Square Flange Receptacle with 360° Accessory Teeth per MS3155 |
| 1 | Threaded, Hermetic Solder Mount Receptacle                              |
| 2 | Threaded, Hermetic Square Flange Receptacle                             |
| 3 | Threaded, Hermetic Jam Nut (D-Hole Mount) Receptacle                    |
| 6 | Threaded, Non-Decoupling Plug with 360° Accessory Teeth per MS3155      |

**Step 4.** Select a Shell Size & Insert Arrangement from chart on pg. 146.

Shell Size & Insert Arrangements are on page 146. First number represents Shell Size, second number is the Insert Arrangement.

**Step 5.** Select a Contact Type (Crimp)

|   | Designates      |
|---|-----------------|
| P | Pin Contacts    |
| S | Socket Contacts |

All connectors are supplied without contacts except Shell Styles 1, 2 and 3

**Step 7.** Select an Alternate Keying Position - Rotation of master key/keyway of shell.

Use N for normal. Use 6, 7, 8, 9 or Y for alternate keying positions. See page 146 for descriptions.

**Step 8.** Variations

|           | Designates                     |
|-----------|--------------------------------|
| O (Alpha) | Basic Connector, no Variations |
| A         | Lockwire Holes on Plug         |

38999  
SJT I II III

26482  
Matrix 2

83723 III  
Matrix Pyle

5015  
Crimp Rear  
Release Matrix

26500 Pyle

Printed  
Circuit Board

EMI Filter  
Transient

Fiber Optics

High Speed  
Contacts

Options  
Others

- III 38999
- II 26482 Matrix 2
- I 83723 III Matrix Pyle
- SJT
- 5015 Crimp Rear Release Matrix
- 26500 Pyle
- Printed Circuit Board
- EMI Filter Transient
- Fiber Optics
- High Speed Contacts
- Options Others

|   | 1.                           | 2.                       | 3.  | 4.                       | 5.                         | 6.  | 7.                        |
|---|------------------------------|--------------------------|---|--------------------------|----------------------------|---|---------------------------|
| MIL-DTL-83723, Series III<br>COMMERCIAL | Connector Type<br><b>HTK</b> | Shell Style<br><b>12</b> | Shell Size/Insert Arrangement<br><b>16-24</b> | Contact Type<br><b>S</b> | Contact Finish<br><b>D</b> | Alternate Keying Position of Shell<br><b>06</b> | Variations<br><b>XXXX</b> |

### Step 1. Select a Commercial Connector Type Equivalent to ESC11 European Specifications

|            | Designates   |
|------------|--|
| <b>HTK</b> | Threaded, Basic ESC-11, Class K (Choice of temperature rating 260° or 200° is in the Variations for this part number). |
| <b>HNK</b> | Same as HTK except Electroless Nickel Plated   |
| <b>HSK</b> | Same as HTK, except this is a special designator for Boeing Company  |

### Step 2. Select a Shell Style

|            | Designates   |
|------------|--|
| <b>-12</b> | Threaded Non-Decoupling Plug with 100% Scoop-Proof Recessed Pins |
| <b>-17</b> | Square Flange Receptacle with 100% Scoop-Proof Recessed Pins     |

### Step 3. Select a Shell Size & Insert Arrangement.

Shell Sizes 12, 14, 18, 20, 24, 28 are available. Insert Arrangements for these size shells are given on page 146. Shell size and insert arrangement are written together. First number represents Shell Size, second number is the Insert Arrangement.

### Step 4. Select a Contact Type (Crimp)

|          | Designates      |
|----------|-----------------|
| <b>P</b> | Pin Contacts    |
| <b>S</b> | Socket Contacts |

### Step 5. Select a Contact Finish or without Contacts

|          | Designates        |
|----------|-------------------|
| <b>D</b> | Gold per AS39029* |
| <b>E</b> | Socket Contacts   |

Special High Temperature Contacts are another option - consult Amphenol Aerospace for ordering information.

### Step 6. Select an Alternate Keying Position - Rotation of master key/keyway of shell.

Use N for normal. Use 06, 07, 08, 09 or Y for alternate keying positions. See page 146 for descriptions.

### Step 7. Variations

|             | Designates |
|-------------|------------|
| <b>Y144</b> | 260°C      |
| <b>Y163</b> | 200°C      |

\*supersedes MIL-C-39029



- 38999 MIL-DTL-83723, Series III
- SJT I II III
- 26482 Matrix 2
- 83723 III Pyle
- Matrix
- 5015 Crimp Rear Release Matrix
- 26500 Pyle
- Printed Circuit Board
- EMI Filter Transient
- Fiber Optics
- High Speed Contacts
- Options Others

|  | 1.             | 2.                                       | 3.            | 4.                             | 5.                                 |
|--|----------------|--|---------------|--------------------------------|------------------------------------|
| MIL-DTL-83723, Series III<br>MILITARY HERMETIC | Connector Type | Connector Style and Contact Type (Crimp) | Service Class | Shell Size/ Insert Arrangement | Alternate Keying Position of Shell |
|  | M83723         | /88                                      | y             | 16-24                          | 6                                  |

|   | 1.              | 2.          | 3.                             | 4.           | 5.            | 6.                       | 7.                                 | 8.         |
|---|-----------------|-------------|--------------------------------|--------------|---------------|--------------------------|------------------------------------|------------|
| Amphenol® Pyle®<br>MIL-DTL-83723, Series III<br>COMMERCIAL HERMETIC | Connector Style | Shell Style | Shell Size/ Insert Arrangement | Contact Type | Contact Style | Alternate Contact Finish | Alternate Keying Position of Shell | Variations |
|   | BTY             | -17         | 16-24                          | S            | 1             | D                        | 06                                 | XXXX       |

#### Step 1. Military Connector Type

|               |   |
|---------------|---|
| <b>M83723</b> | <b>Designates MIL-DTL-83723 Series III Connectors</b> |
|---------------|---|

#### Step 2. Select a Military Hermetic Connector Style

(Refer to military specification slash sheet number.)

|            | Designates   |
|------------|--|
| <b>/88</b> | Hermetic, Threaded Square Flange Receptacle          |
| <b>/89</b> | Hermetic, Threaded Jam Nut (D-Hole Mount) Receptacle |
| <b>/90</b> | Hermetic, Threaded Solder Mounted Receptacle         |

#### Step 3. Select a Service Class

|          | Designates   |
|----------|--|
| <b>Y</b> | Hermetic, Stainless Steel, 200°C, with Solderwell Contacts |
| <b>P</b> | Hermetic, Stainless Steel, 200°C, with Eyelet Contacts     |

For availability of a Plated Steel Shell, consult Amphenol Aerospace.

#### Step 4. Select a Shell Size & Insert Arrangement from chart on pg. 146. (except sizes 24 and 28 are not available in Hermetic Styles.)

Shell Size & Insert Arrangements are on page 146. First number represents Shell Size, second number is the Insert Arrangement

#### Step 5. Select an Alternate Keying Position - Rotation of master key/keyway of shell.

Use N for normal. Use 6, 7, 8, 9 or Y for alternate keying positions. See page 146 for descriptions.

#### Step 1. Select a Commercial Hermetic Connector Style

|            | Designates   |
|------------|--|
| <b>BTY</b> | Hermetic, Threaded, Stainless Steel, with 'O' ring seal  |
| <b>BFY</b> | Hermetic, Threaded, Stainless Steel, with Static/Dynamic Seal                                  |
| <b>BNY</b> | Hermetic, Threaded, Stainless Steel, Electro-deposited Nickel plated, with Static/Dynamic Seal |

#### Step 2. Select a Shell Style

|            | Designates                        |
|------------|-----------------------------------|
| <b>-17</b> | Square Flange Receptacle          |
| <b>-19</b> | Jam Nut (D-Hole Mount) Receptacle |
| <b>-14</b> | Solder Mounted Receptacle         |

#### Step 3. Select a Shell Size & Insert Arrangement from chart on pg. 146. (except sizes 24 and 28 are not available in Hermetic Styles).

Shell Size & Insert Arrangements are on page 146. First number represents Shell Size, second number is the Insert Arrangement

#### Step 4. Select a Contact Type (Crimp)

|          | Designates   |
|----------|--------------|
| <b>P</b> | Pin Contacts |

#### Step 5. Select a Contact Style

|          | Designates                          |
|----------|-------------------------------------|
| <b>1</b> | Solderwell Contacts (Mil-Spec Type) |
| <b>4</b> | Eyelet Contacts                     |

#### Step 6. Alternate Contact Finish

|          | Designates                            |
|----------|---------------------------------------|
| <b>D</b> | .000050 (per MIL-DTL-83723, III) Gold |
| <b>V</b> | .000100 Gold                          |

#### Step 7. Select an Alternate Keying Position - Rotation of master key/keyway of shell.

Omit for normal. Use 06, 07, 08, 09 or Y for alternate keying positions. See page 146 for descriptions.

#### Step 8. Variations

|             | Designates                                   |
|-------------|--|
| <b>Y144</b> | 260°C Capability (Euro Market)               |
| <b>Y163</b> | 200°C Capability (Euro Market)               |
| <b>Y186</b> | 260°C Capability per G.E. M50TF3564, Class B |
| <b>Y188</b> | 200°C Capability per G.E. M50TF3564, Class A |

# MIL-DTL-83723, Series III, Pyle®

## Square Flange Receptacle, Threaded Coupling

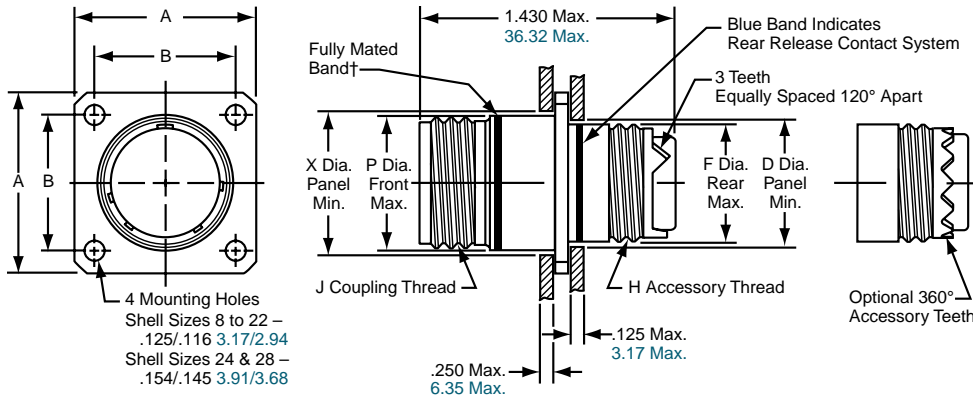

### PART #

**M83723/82 / M83723/83**  
**BT ( )-17**  
**BJ/BJ8/BN/BN8/BNK-17**  
**BACC63CN**  
**BSK-17**  
**EN2997( )**  
**BT ( )/BJ ( )-17**  
**ESC10( )**  
**ESC11( )**  
**HTK/HNK/HSK-17**

† When fully mated with plug this band will be covered. (Band is red on military types; can be red or blue on commercial types).

See Quick Reference page 140 for the variety of ordering options for square flange receptacles with threaded coupling.

The How to Order pages (149-156) give complete part number breakdowns.

Inches

| Shell Size | A ±.005 | B ±.005 | D Dia. Panel Min. | F Dia. Rear Max. | H Accessory Thread Class 2A | J Coupling Thread Class 2A | P Dia. Front Max. | X Dia. Panel Min. |
|------------|---------|---------|-------------------|------------------|-----------------------------|----------------------------|-------------------|-------------------|
| 8          | .812    | .594    | .510              | .500             | .5000-20 UNF                | .5625-24 UNF               | .562              | .620              |
| 10         | .937    | .719    | .635              | .625             | .6250-24 UNEF               | .6875-24 UNEF              | .696              | .748              |
| 12         | 1.031   | .812    | .760              | .750             | .7500-20 UNEF               | .8750-20 UNEF              | .875              | .913              |
| 14         | 1.125   | .906    | .885              | .875             | .8750-20 UNEF               | .9375-20 UNEF              | .936              | .980              |
| 16         | 1.250   | .969    | 1.010             | 1.000            | 1.0000-20 UNEF              | 1.0625-18 UNEF             | 1.062             | 1.107             |
| 18         | 1.343   | 1.062   | 1.072             | 1.062            | 1.0625-18 UNEF              | 1.1875-18 UNEF             | 1.187             | 1.209             |
| 20         | 1.437   | 1.156   | 1.192             | 1.187            | 1.1875-18 UNEF              | 1.3125-18 UNEF             | 1.312             | 1.337             |
| 22         | 1.562   | 1.250   | 1.322             | 1.312            | 1.3125-18 UNEF              | 1.4375-18 UNEF             | 1.437             | 1.452             |
| 24         | 1.703   | 1.375   | 1.447             | 1.437            | 1.4375-18 UNEF              | 1.5625-18 UNEF             | 1.562             | 1.577             |
| 28         | 1.953   | 1.562   | 1.760             | 1.750            | 1.7500-18 UNEF              | 1.8125-16 UNEF             | 1.812             | 1.827             |

Millimeters

| Shell Size | A ±.005 | B ±.005 | D Dia. Panel Min. | F Dia. Rear Max. | P Dia. Front Max. | X Dia. Panel Min. |
|------------|---------|---------|-------------------|------------------|-------------------|-------------------|
| 8          | 20.62   | 15.09   | 12.95             | 12.70            | 14.27             | 15.75             |
| 10         | 23.80   | 18.26   | 16.13             | 15.88            | 17.68             | 18.99             |
| 12         | 26.19   | 20.62   | 19.30             | 19.05            | 22.23             | 23.19             |
| 14         | 28.58   | 23.01   | 22.48             | 22.23            | 23.77             | 24.89             |
| 16         | 31.75   | 24.61   | 25.65             | 25.40            | 26.97             | 28.12             |
| 18         | 34.11   | 26.97   | 27.23             | 26.97            | 30.15             | 30.71             |
| 20         | 36.50   | 29.36   | 30.28             | 30.15            | 33.32             | 33.96             |
| 22         | 39.67   | 31.75   | 33.58             | 33.32            | 36.50             | 36.88             |
| 24         | 43.26   | 34.93   | 36.75             | 36.50            | 39.67             | 40.06             |
| 28         | 49.61   | 39.67   | 44.70             | 44.45            | 46.02             | 46.41             |

Shell sizes 8 and 10 are not available in Boeing BACC63 styles and commercial ESC11 styles. Bayonet style square flange receptacles are shown on page 160. Hermetic threaded style square flange receptacles are shown on page 163. All dimensions for reference only.

III  
II  
I  
SJT  
38999

Matrix 2  
26482

Matrix Pyle  
83723 III

Crimp Rear Release Matrix  
5015

26500 Pyle

Printed Circuit Board

EMI Filter Transient

Fiber Optics

High Speed Contacts

Options Others

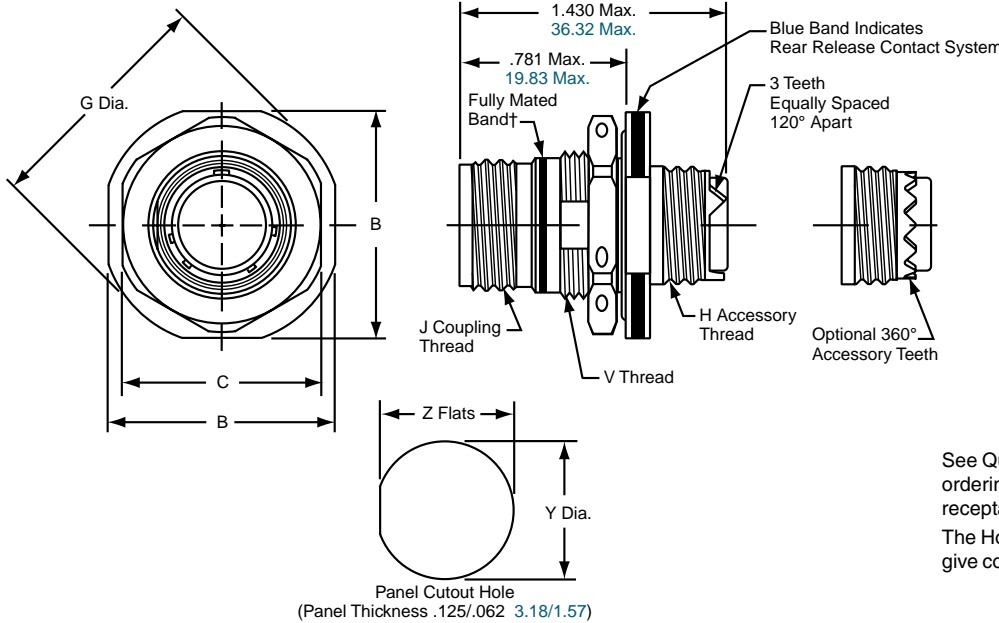

**PART #**

**M83723/84 / M83723/85**  
**BT( )-19**  
**BJ/BJ8/BN/BN8/BNK-19**  
**EN2997( )7**  
**BT( )/BJ( )-19**

See Quick Reference page 141 for the variety of ordering options for jam nut (D-hole mount) receptacles with threaded coupling.  
The How to Order pages (149, 150, 152, 153) give complete part number breakdowns.

† When fully mated with plug this band will be covered.  
(Band is red on military types; can be red or blue on commercial types).

Inches

| Shell Size | B Max. | C Hex Max. | G Dia. Max. | H Accessory Thread Class 2A | J Coupling Thread Class 2A | V Thread Class 2A | Y Dia. ±.005 | Z Flats ±.005 |
|------------|--------|------------|-------------|-----------------------------|----------------------------|-------------------|--------------|---------------|
| 8          | .979   | .828       | 1.068       | .5000-20 UNF                | .5625-24 UNF               | .6250-20 UNEF     | .635         | .605          |
| 10         | 1.104  | .953       | 1.192       | .6250-24 UNEF               | .6875-24 UNEF              | .7500-20 UNEF     | .760         | .730          |
| 12         | 1.291  | 1.140      | 1.380       | .7500-20 UNEF               | .8750-20 UNEF              | .9380-20 UNEF     | .947         | .917          |
| 14         | 1.391  | 1.205      | 1.505       | .8750-20 UNEF               | .9375-20 UNEF              | 1.0000-20 UNEF    | 1.010        | .980          |
| 16         | 1.516  | 1.329      | 1.630       | 1.0000-20 UNEF              | 1.0625-18 UNEF             | 1.1250-18 UNEF    | 1.135        | 1.105         |
| 18         | 1.641  | 1.455      | 1.756       | 1.0625-18 UNEF              | 1.1875-18 UNEF             | 1.2500-18 UNEF    | 1.260        | 1.225         |
| 20         | 1.766  | 1.574      | 1.860       | 1.1875-18 UNEF              | 1.3125-18 UNEF             | 1.3750-18 UNEF    | 1.385        | 1.350         |
| 22         | 1.954  | 1.705      | 2.068       | 1.3125-18 UNEF              | 1.4375-18 UNEF             | 1.5000-18 UNEF    | 1.510        | 1.475         |
| 24         | 2.074  | 1.830      | 2.160       | 1.4375-18 UNEF              | 1.5625-18 UNEF             | 1.6250-18 UNEF    | 1.635        | 1.600         |
| 28         | 2.329  | 2.080      | —           | 1.7500-18 UNEF              | 1.8125-16 UNEF             | 1.8750-20 UNEF    | 1.885        | 1.850         |

Millimeters

| Shell Size | B Max. | C Hex Max. | G Dia. Max. | Y Dia. ±.13 | Z Flats ±.13 |
|------------|--------|------------|-------------|-------------|--------------|
| 8          | 24.87  | 21.03      | 27.13       | 16.13       | 15.37        |
| 10         | 28.04  | 24.21      | 30.28       | 19.30       | 18.54        |
| 12         | 32.79  | 28.96      | 35.05       | 24.05       | 23.29        |
| 14         | 35.33  | 30.61      | 38.23       | 25.65       | 24.89        |
| 16         | 38.51  | 33.76      | 41.40       | 28.83       | 28.07        |
| 18         | 41.68  | 36.96      | 44.60       | 32.00       | 31.12        |
| 20         | 44.86  | 39.98      | 47.24       | 35.18       | 34.29        |
| 22         | 49.63  | 43.31      | 52.53       | 38.35       | 37.47        |
| 24         | 52.68  | 46.48      | 80.26       | 41.53       | 40.64        |
| 28         | 59.16  | 52.83      | —           | 47.88       | 46.99        |

No Boeing Designated jam nut receptacles.  
Bayonet style jam nut receptacles shown on page 161.  
Hermetic threaded style jam nut receptacles shown on page 164.  
All dimensions for reference only.

# MIL-DTL-83723, Series III, Pyle®

## Straight Plug and Non-Decoupling Plug, Threaded Coupling

### Straight Plug

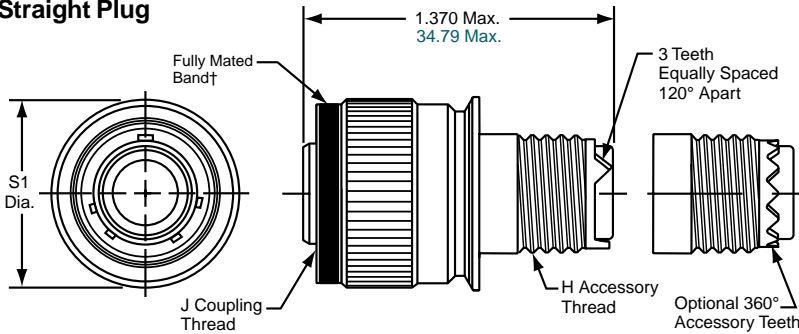

### Non-Decoupling Plug

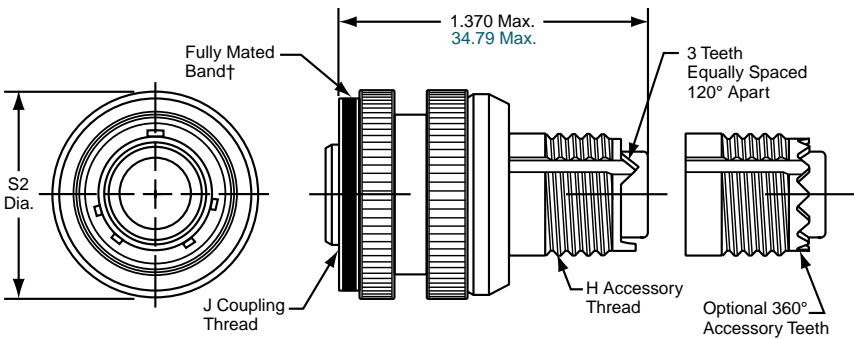

† When fully mated with receptacle this band will be covered. (Band is red on military types; can be red or blue on commercial types).

Inches

| Shell Size | H Accessory Thread Class 2A | J Coupling Thread Class 2A | S1 Dia. Max. | S2 Dia. Max. |
|------------|-----------------------------|----------------------------|--------------|--------------|
| 8          | .5000-20 UNF                | .5625-24 UNF               | .776         | .832         |
| 10         | .6250-24 UNEF               | .6875-24 UNEF              | .906         | .958         |
| 12         | .7500-20 UNEF               | .8750-20 UNEF              | 1.078        | 1.090        |
| 14         | .8750-20 UNEF               | .9375-20 UNEF              | 1.141        | 1.203        |
| 16         | 1.0000-20 UNEF              | 1.0625-18 UNEF             | 1.266        | 1.326        |
| 18         | 1.0625-18 UNEF              | 1.1875-18 UNEF             | 1.375        | 1.432        |
| 20         | 1.1875-18 UNEF              | 1.3125-18 UNEF             | 1.500        | 1.557        |
| 22         | 1.3125-18 UNEF              | 1.4375-18 UNEF             | 1.625        | 1.682        |
| 24         | 1.4375-18 UNEF              | 1.5625-18 UNEF             | 1.750        | 1.817        |
| 28         | 1.7500-18 UNEF              | 1.8125-16 UNEF             | 2.000        | 2.122        |

Millimeters

| Shell Size | S1 Dia. Max. | S2 Dia. Max. |
|------------|--------------|--------------|
| 8          | 19.71        | 21.13        |
| 10         | 23.01        | 24.33        |
| 12         | 27.38        | 27.68        |
| 14         | 28.98        | 30.55        |
| 16         | 32.15        | 33.68        |
| 18         | 34.92        | 36.37        |
| 20         | 38.10        | 39.54        |
| 22         | 41.27        | 42.72        |
| 24         | 44.45        | 46.15        |
| 28         | 50.80        | 53.89        |

Shell sizes 8 and 10 are not available in Boeing BACC63 styles and commercial ESC11 styles. Boeing designations are in non-decoupling plugs only; not in straight plug designations. ASD and European/ESC10 or ESC11 are in non-decoupling plugs only, not in straight plug designations. Bayonet style straight plugs shown on page 162. Bayonet style non-decoupling plugs are not available.

All dimensions for reference only.

### PART # STRAIGHT PLUG

M83723/86 / M83723/87

BT( )-11

BJ/BJ8/BN/BN8/BNK-11

See Quick Reference page 142 for the variety of ordering options for straight plugs with threaded coupling. The How to Order pages (149, 150,153) give complete part number breakdowns.

### PART # NON-DECOUPLING PLUG

M83723/95 / M83723/96

M83723/97 / M83723/98

BT( )-12

BJ/BJ8/BN/BN8/BNK-12

BACC63CM

BSK-12

EN2997( )6

BT( )/BJ( )-12

ESC10( )6

ESC11( )6

HTK/HNK/HSK-12

See Quick Reference page 142 for the variety of ordering options for non-decoupling plugs with threaded coupling. The How to Order pages (149-156) give complete part number breakdowns.

III  
II  
I  
SJT  
38999

Matrix 2  
26482

Matrix Pyle  
83723 III

Release Matrix  
5015  
Crimp Rear

26500 Pyle

Printed  
Circuit Board

EMI Filter  
Transient

Fiber Optics

High Speed  
Contacts

Options  
Others

### PART #

**M83723/71 / M83723/72**

**BY( )-17**

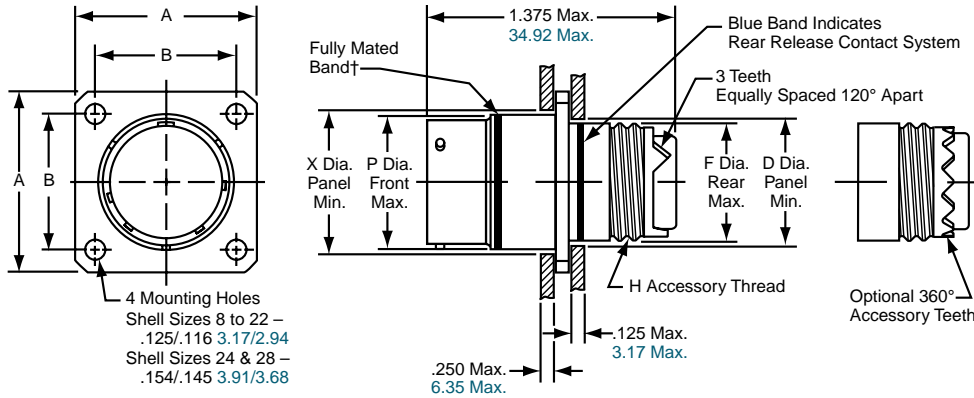

See Quick Reference page 143 for the variety of ordering options for square flange receptacles with bayonet coupling.

The How to Order page 149 gives complete part number breakdowns.

† When fully mated with plug this band will be covered. (Band is red on military types; can be red or blue on commercial types).

Inches

| Shell Size | A<br>±.005 | B<br>±.005 | D Dia.<br>Panel<br>Min. | F Dia.<br>Rear<br>Max. | H<br>Accessory Thread<br>Class 2A | P Dia.<br>Front<br>Max. | X Dia.<br>Panel<br>Min. |
|------------|------------|------------|-------------------------|------------------------|-----------------------------------|-------------------------|-------------------------|
| 8          | .812       | .594       | .510                    | .500                   | .5000-20 UNF                      | .562                    | .620                    |
| 10         | .937       | .719       | .635                    | .625                   | .6250-24 UNEF                     | .696                    | .748                    |
| 12         | 1.031      | .812       | .760                    | .750                   | .7500-20 UNEF                     | .875                    | .913                    |
| 14         | 1.125      | .906       | .885                    | .875                   | .8750-20 UNEF                     | .936                    | .980                    |
| 16         | 1.250      | .969       | 1.010                   | 1.000                  | 1.0000-20 UNEF                    | 1.062                   | 1.107                   |
| 18         | 1.343      | 1.062      | 1.072                   | 1.062                  | 1.0625-18 UNEF                    | 1.187                   | 1.209                   |
| 20         | 1.437      | 1.156      | 1.192                   | 1.187                  | 1.1875-18 UNEF                    | 1.312                   | 1.337                   |
| 22         | 1.562      | 1.250      | 1.322                   | 1.312                  | 1.3125-18 UNEF                    | 1.437                   | 1.452                   |
| 24         | 1.703      | 1.375      | 1.447                   | 1.437                  | 1.4375-18 UNEF                    | 1.562                   | 1.577                   |

Millimeters

| Shell Size | A<br>±.005 | B<br>±.005 | D Dia.<br>Panel<br>Min. | F Dia.<br>Rear<br>Max. | P Dia.<br>Front<br>Max. | X Dia.<br>Panel<br>Min. |
|------------|------------|------------|-------------------------|------------------------|-------------------------|-------------------------|
| 8          | 20.62      | 15.04      | 12.95                   | 12.70                  | 14.27                   | 15.75                   |
| 10         | 23.80      | 18.26      | 16.13                   | 15.88                  | 17.68                   | 18.99                   |
| 12         | 26.19      | 20.62      | 19.30                   | 19.05                  | 22.23                   | 23.19                   |
| 14         | 28.58      | 23.01      | 22.48                   | 22.23                  | 23.77                   | 24.89                   |
| 16         | 31.75      | 24.61      | 25.65                   | 25.40                  | 26.97                   | 28.12                   |
| 18         | 34.11      | 26.97      | 27.23                   | 26.97                  | 30.15                   | 30.71                   |
| 20         | 36.50      | 29.36      | 30.28                   | 30.15                  | 33.32                   | 33.96                   |
| 22         | 39.67      | 31.75      | 33.58                   | 33.32                  | 36.50                   | 36.88                   |
| 24         | 43.26      | 34.93      | 36.75                   | 36.50                  | 39.67                   | 40.06                   |

Bayonet coupling connectors are offered in Military 83723 and Commercial equivalent designations. They are not included in Boeing, GE, ASD and other European specified connectors.

Shell size 28 is not available in Bayonet coupling connectors.

All dimensions for reference only.



# MIL-DTL-83723, Series III, Pyle®

## Jam Nut (D-Hole Mount) Receptacle, Bayonet Coupling

### PART #

**M83723/73 / M83723/74**

**BY( )-19**

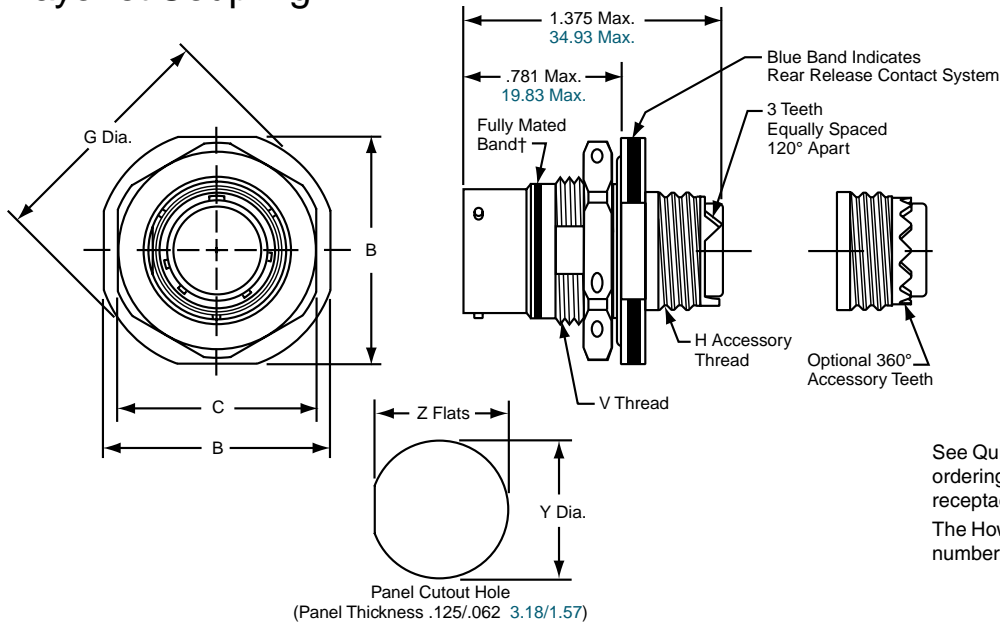

See Quick Reference page 143 for the variety of ordering options for jam nut D-hole mount receptacles with bayonet coupling. The How to Order page 149 gives complete part number breakdowns.

† When fully mated with plug this band will be covered.  
(Band is red on military types; can be red or blue on commercial types).

Inches

| Shell Size | B Flats Max. | C Hex Max. | G Dia. Max. | H Accessory Thread Class 2A | V Thread Class 2A | Y Dia. ±.005 | Z Flats ±.005 |
|------------|--------------|------------|-------------|-----------------------------|-------------------|--------------|---------------|
| 8          | .979         | .828       | 1.068       | .5000-20 UNF                | .6250-20 UNEF     | .635         | .605          |
| 10         | 1.104        | .953       | 1.192       | .6250-24 UNEF               | .7500-20 UNEF     | .760         | .730          |
| 12         | 1.291        | 1.140      | 1.380       | .7500-20 UNEF               | .9380-20 UNEF     | .947         | .917          |
| 14         | 1.391        | 1.205      | 1.505       | .8750-20 UNEF               | 1.0000-20 UNEF    | 1.010        | .980          |
| 16         | 1.516        | 1.329      | 1.630       | 1.0000-20 UNEF              | 1.1250-20 UNEF    | 1.135        | 1.105         |
| 18         | 1.641        | 1.455      | 1.756       | 1.0625-18 UNEF              | 1.2500-18 UNEF    | 1.260        | 1.225         |
| 20         | 1.766        | 1.574      | 1.860       | 1.1875-18 UNEF              | 1.3750-18 UNEF    | 1.385        | 1.350         |
| 22         | 1.954        | 1.705      | 2.068       | 1.3125-18 UNEF              | 1.5000-18 UNEF    | 1.510        | 1.475         |
| 24         | 2.074        | 1.830      | 2.160       | 1.4375-18 UNEF              | 1.6250-18 UNEF    | 1.635        | 1.600         |

Millimeters

| Shell Size | B Flats Max. | C Hex Max. | G Dia. Max. | Y Dia. ±.13 | Z Flats ±.13 |
|------------|--------------|------------|-------------|-------------|--------------|
| 8          | 24.87        | 21.03      | 27.13       | 16.13       | 15.37        |
| 10         | 28.04        | 24.21      | 30.28       | 19.30       | 18.54        |
| 12         | 32.79        | 28.96      | 35.05       | 24.05       | 23.29        |
| 14         | 35.33        | 30.61      | 38.23       | 25.65       | 24.89        |
| 16         | 38.51        | 33.76      | 41.40       | 28.83       | 28.07        |
| 18         | 41.68        | 36.96      | 44.60       | 32.00       | 31.12        |
| 20         | 44.86        | 39.98      | 47.24       | 35.18       | 34.29        |
| 22         | 49.63        | 43.31      | 52.53       | 38.35       | 37.47        |
| 24         | 52.68        | 46.48      | 80.26       | 41.53       | 40.64        |

Bayonet coupling connectors are offered in Military 83723 and Commercial equivalent designations. They are not included in Boeing, GE, ASD and other European specified connectors.

Shell size 28 is not available in Bayonet coupling connectors.

All dimensions for reference only.

III 38999  
II 1  
I SJT

26482  
Matrix 2

83723 III  
Matrix Pyle

5015  
Crimp Rear  
Release Matrix

26500 Pyle

Printed  
Circuit Board

EMI Filter  
Transient

Fiber Optics

High Speed  
Contacts

Options  
Others

### PART #

M83723/75 / M83723/76

BY( )-10

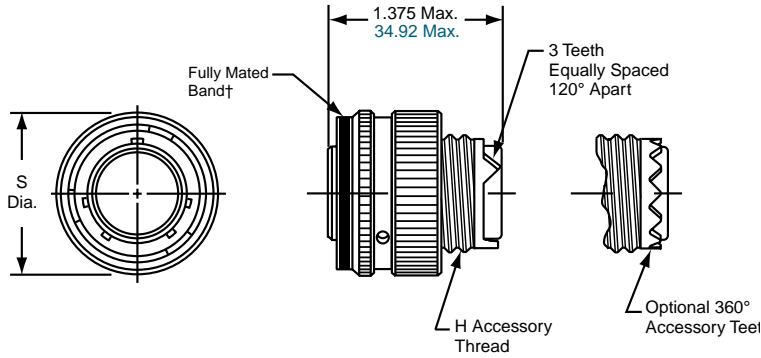

See Quick Reference page 143 for the variety of ordering options for straight plugs with bayonet coupling.

The How to Order page 149 gives complete part number breakdowns.

† When fully mated with receptacle this band will be covered. (Band is red on military types; can be red or blue on commercial types).

Inches

| Shell Size | H Accessory Thread Class 2A | S Dia. Max. |
|------------|-----------------------------|-------------|
| 8          | .5000-20 UNF                | .765        |
| 10         | .6250-24 UNEF               | .906        |
| 12         | .7500-20 UNEF               | 1.078       |
| 14         | .8750-20 UNEF               | 1.125       |
| 16         | 1.0000-20 UNEF              | 1.266       |
| 18         | 1.0625-18 UNEF              | 1.375       |
| 20         | 1.1875-18 UNEF              | 1.505       |
| 22         | 1.3125-18 UNEF              | 1.625       |
| 24         | 1.4375-18 UNEF              | 1.755       |

Millimeters

| Shell Size | S Dia. Max. |
|------------|-------------|
| 8          | 19.43       |
| 10         | 23.01       |
| 12         | 27.38       |
| 14         | 28.57       |
| 16         | 32.15       |
| 18         | 34.92       |
| 20         | 38.22       |
| 22         | 41.27       |
| 24         | 44.57       |

Bayonet coupling connectors are offered in Military 83723 and Commercial equivalent designations. They are not included in Boeing, GE, ASD and other European specified connectors.

Shell size 28 is not available in Bayonet coupling connectors.

All dimensions for reference only.

83723 III  
Matrix Pyle

5015  
Crimp Rear  
Release Matrix

26500 Pyle

Printed  
Circuit Board

EMI Filter  
Transient

Fiber Optics

High Speed  
Contacts

Options  
Others

38999  
SJT I II III

26482  
Matrix 2

# MIL-DTL-83723, Series III, Pyle®

## Hermetic Square Flange Mount Receptacle, Threaded Coupling

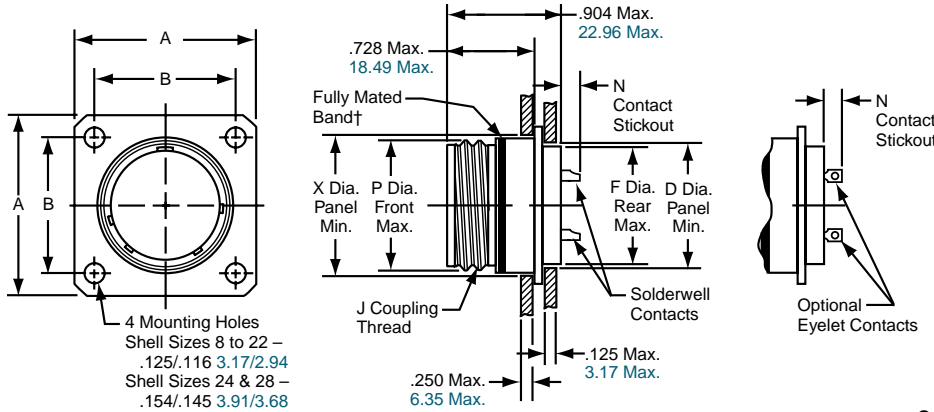

**PART #**  
**M83723/88Y / M83723/88P**  
**BTY/BFY/BNY-17**  
**EN2997Y0 /YE0**  
**ESC10YE2**  
**ESC11YE2**

† When fully mated with plug this band will be covered. (Band is red on military types; can be red or blue on commercial types).

See Quick Reference page 144 for the variety of ordering options for hermetic square flange mount receptacles with threaded coupling. The How to Order pages (152, 154, 156) give complete part number breakdowns.

Inches

| Shell Size | A<br>±.010 | B<br>±.005 | D Dia. Panel Min. | F Dia. Rear Max. | J Coupling Thread Class 2A | N Contact Stickout |                       | P Dia. Front Max. | X Dia. Panel Min. |
|------------|------------|------------|-------------------|------------------|----------------------------|--------------------|-----------------------|-------------------|-------------------|
|            |            |            |                   |                  |                            | Size 20 Contacts   | Size 12 & 16 Contacts |                   |                   |
| 8          | .812       | .594       | .510              | .500             | .5625-24 UNF               | .194 / .134        | .224 / .164           | .562              | .572              |
| 10         | .937       | .719       | .635              | .625             | .6875-24 UNEF              | .194 / .134        | .224 / .164           | .696              | .706              |
| 12         | 1.031      | .812       | .760              | .750             | .8750-20 UNEF              | .194 / .134        | .224 / .164           | .875              | .885              |
| 14         | 1.125      | .906       | .885              | .875             | .9375-20 UNEF              | .194 / .134        | .224 / .164           | .936              | .946              |
| 16         | 1.250      | .969       | 1.010             | 1.000            | 1.0625-18 UNEF             | .194 / .134        | .224 / .164           | 1.062             | 1.072             |
| 18         | 1.343      | 1.062      | 1.072             | 1.062            | 1.1875-18 UNEF             | .194 / .134        | .224 / .164           | 1.187             | 1.197             |
| 22         | 1.562      | 1.250      | 1.322             | 1.312            | 1.4375-18 UNEF             | .194 / .134        | .224 / .164           | 1.437             | 1.447             |

Millimeters

| Shell Size | A<br>±.25 | B<br>±.13 | D Dia. Panel Min. | F Dia. Rear Max. | P Dia. Front Max. | X Dia. Panel Min. |
|------------|-----------|-----------|-------------------|------------------|-------------------|-------------------|
| 8          | 20.62     | 15.09     | 12.95             | 12.70            | 14.27             | 15.75             |
| 10         | 23.80     | 18.26     | 16.13             | 15.88            | 17.68             | 18.99             |
| 12         | 26.19     | 20.62     | 19.30             | 19.05            | 22.23             | 23.19             |
| 14         | 28.58     | 23.01     | 22.48             | 22.23            | 23.77             | 24.89             |
| 16         | 31.75     | 24.61     | 25.65             | 25.40            | 26.97             | 28.12             |
| 18         | 34.11     | 26.97     | 27.23             | 26.97            | 30.15             | 30.71             |
| 22         | 39.67     | 31.75     | 33.58             | 33.32            | 36.50             | 36.88             |

Hermetic style receptacles are not included in Boeing designations. Commercial hermetics meet some European and GE specifications. Hermetic styles are threaded coupling only. Shell sizes 20, 24 and 28, consult Amphenol for availability. All dimensions for reference only.

- III 38999
- II 26482
- I Matrix 2
- SJT
- Matrix Pyle 83723 III
- Crimp Rear Release Matrix 5015
- 26500 Pyle
- Printed Circuit Board
- EMI Filter Transient
- Fiber Optics
- High Speed Contacts
- Options Others

**MIL-DTL-83723, Series III, Pyle®**  
Hermetic Jam Nut (D-Hole Mount) Receptacle,  
Threaded Coupling

**PART #**  
M83723/89Y / M83723/89P  
BTY/BFY/BNY-19  
EN2997Y7 / YE7  
ESC10YE3  
ESC11YE3

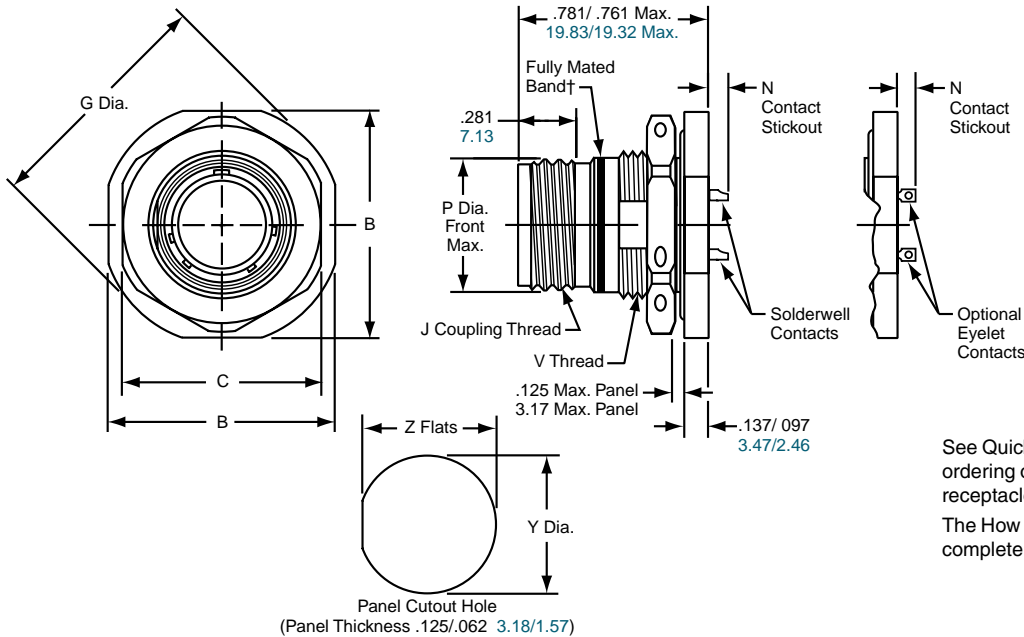

See Quick Reference page 144 for the variety of ordering options for hermetic jam nut D-hole mount receptacles with threaded coupling. The How to Order pages (152, 154, 156) give complete part number breakdowns.

† When fully mated with plug this band will be covered. (Band is red on military types; can be red or blue on commercial types).

Inches

| Shell Size | B Flats Max. | C Hex Max. | G Dia. Max. | J Coupling Thread Class 2A | N Contact Stickout |                       | P Dia. Front Max. | V Thread Class 2A | Y Dia. ±.005 | Z Flats ±.005 |
|------------|--------------|------------|-------------|----------------------------|--------------------|-----------------------|-------------------|-------------------|--------------|---------------|
|            |              |            |             |                            | Size 20 Contacts   | Size 12 & 16 Contacts |                   |                   |              |               |
| 8          | .980         | .828       | 1.068       | .5625-24 UNF               | .180 / .120        | .210 / .150           | .562              | .6250-20 UNF      | .635         | .605          |
| 10         | 1.104        | .953       | 1.192       | .6875-24 UNEF              | .180 / .120        | .210 / .150           | .696              | .7500-20 UNEF     | .760         | .730          |
| 12         | 1.291        | 1.140      | 1.380       | .8750-20 UNEF              | .180 / .120        | .210 / .150           | .875              | .9380-20 UNEF     | .947         | .917          |
| 14         | 1.391        | 1.205      | 1.505       | .9375-20 UNEF              | .180 / .120        | .210 / .150           | .936              | 1.0000-20 UNEF    | 1.010        | .980          |
| 16         | 1.516        | 1.329      | 1.630       | 1.0625-18 UNEF             | .180 / .120        | .210 / .150           | 1.062             | 1.1250-18 UNEF    | 1.135        | 1.105         |
| 18         | 1.641        | 1.455      | 1.756       | 1.1875-18 UNEF             | .180 / .120        | .210 / .150           | 1.187             | 1.2500-18 UNEF    | 1.260        | 1.225         |
| 22         | 1.954        | 1.705      | 2.068       | 1.4375-18 UNEF             | .180 / .120        | .210 / .150           | 1.437             | 1.5000-18 UNEF    | 1.510        | 1.475         |

Millimeters

| Shell Size | B Flats Max. | C Hex Max. | G Dia. Max. | N Contact Stickout |                       | P Dia. Front Max. | Y Dia. ±.13 | Z Flats ±.13 |
|------------|--------------|------------|-------------|--------------------|-----------------------|-------------------|-------------|--------------|
|            |              |            |             | Size 20 Contacts   | Size 12 & 16 Contacts |                   |             |              |
| 8          | 24.89        | 21.03      | 27.13       | 4.57 / 3.05        | 5.33 / 3.81           | 14.27             | 16.13       | 15.37        |
| 10         | 28.04        | 24.21      | 30.28       | 4.57 / 3.05        | 5.33 / 3.81           | 17.68             | 19.30       | 18.54        |
| 12         | 32.79        | 28.96      | 35.05       | 4.57 / 3.05        | 5.33 / 3.81           | 22.23             | 24.05       | 23.29        |
| 14         | 35.33        | 30.61      | 38.23       | 4.57 / 3.05        | 5.33 / 3.81           | 23.77             | 25.65       | 24.89        |
| 16         | 38.51        | 33.76      | 41.40       | 4.57 / 3.05        | 5.33 / 3.81           | 26.97             | 28.83       | 28.07        |
| 18         | 41.68        | 36.96      | 44.60       | 4.57 / 3.05        | 5.33 / 3.81           | 30.15             | 32.00       | 31.12        |
| 22         | 49.63        | 43.31      | 52.53       | 4.57 / 3.05        | 5.33 / 3.81           | 36.47             | 38.35       | 37.47        |

Hermetic style receptacles are not included in Boeing designations. Commercial hermetics meet some European and GE specifications. Hermetic styles are threaded coupling only. Shell sizes 20, 24 and 28, consult Amphenol for availability. All dimensions for reference only.

38999  
SJT I II III

26482  
Matrix 2

83723 III  
Matrix Pyle

5015  
Crimp Rear Release Matrix

26500 Pyle

Printed  
Circuit Board

EMI Filter  
Transient

Fiber Optics

High Speed  
Contacts

Options  
Others

# MIL-DTL-83723, Series III, Pyle®

## Hermetic Solder Mount/Weld Mount Receptacle, Threaded Coupling



### PART #

M83723/90Y / M83723/90P

BTY/BFY/BNY-14

EN2997Y1 / YE1

ESC10YE1

ESC11YE1

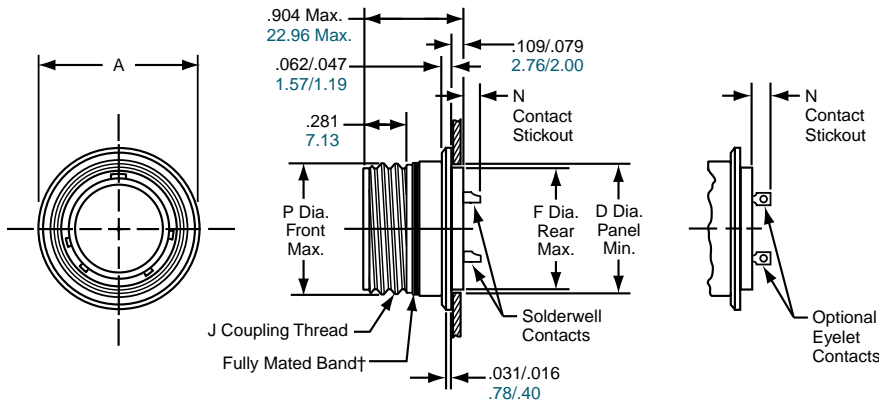

See Quick Reference page 144 for the variety of ordering options for hermetic solder mount / weld mount receptacles with threaded coupling.

The How to Order pages (152, 154, 156) give complete part number breakdowns.

† When fully mated with plug this band will be covered. (Band is red on military types; can be red or blue on commercial types).

Inches

| Shell Size | A Dia. ±.010 | D Dia. Panel Min. | F Dia. Rear Max. | J Coupling Thread Class 2A | N Contact Stickout |                       | P Dia. Front Max. |
|------------|--------------|-------------------|------------------|----------------------------|--------------------|-----------------------|-------------------|
|            |              |                   |                  |                            | Size 20 Contacts   | Size 12 & 16 Contacts |                   |
| 8          | .713         | .510              | .500             | .5625-24 UNF               | .194 / .134        | .224 / .164           | .562              |
| 10         | .840         | .572              | .562             | .6875-24 UNEF              | .194 / .134        | .224 / .164           | .696              |
| 12         | 1.045        | .760              | .750             | .8750-20 UNEF              | .194 / .134        | .224 / .164           | .875              |
| 14         | 1.090        | .822              | .812             | .9375-20 UNEF              | .194 / .134        | .224 / .164           | .936              |
| 16         | 1.210        | .947              | .937             | 1.0625-18 UNEF             | .194 / .134        | .224 / .164           | 1.062             |
| 18         | 1.340        | 1.072             | 1.062            | 1.1875-18 UNEF             | .194 / .134        | .224 / .164           | 1.187             |
| 22         | 1.562        | 1.322             | 1.312            | 1.4375-18 UNEF             | .194 / .134        | .224 / .164           | 1.437             |

Millimeters

| Shell Size | A Dia. ±.25 | D Dia. Panel Min. | F Dia. Rear Max. | P Dia. Front Max. |
|------------|-------------|-------------------|------------------|-------------------|
| 8          | 18.11       | 12.95             | 12.70            | 14.27             |
| 10         | 21.34       | 14.53             | 14.27            | 17.68             |
| 12         | 26.54       | 19.30             | 19.05            | 22.23             |
| 14         | 27.69       | 20.88             | 20.62            | 23.77             |
| 16         | 30.73       | 24.05             | 23.80            | 26.97             |
| 18         | 34.04       | 27.23             | 26.97            | 30.15             |
| 22         | 39.67       | 33.58             | 33.32            | 36.50             |

Hermetic style receptacles are not included in Boeing designations. Commercial hermetics meet some European and GE specifications. Hermetic styles are threaded coupling only. Shell sizes 20, 24 and 28, consult Amphenol for availability. All dimensions for reference only.

III 38999  
II 1  
I SJT

Matrix 2 26482

Matrix Pyle 83723 III

Release Matrix 5015 Crimp Rear

26500 Pyle

Printed Circuit Board

EMI Filter Transient

Fiber Optics

High Speed Contacts

Options Others



### STANDARD CRIMP CONTACTS - PIN PART NUMBERS / COLOR BANDS

| Contact Size | Pin MS Spec Number | Pin Pyle Part Number | Pin Color Bands |          |          |
|--------------|--------------------|----------------------|-----------------|----------|----------|
|              |                    |                      | 1st Band        | 2nd Band | 3rd Band |
| 20           | M39029/4-110       | BA-4020-36LD         | Brown           | Brown    | Black    |
| 16           | M39029/4-111       | BA-4016-36LD         | Brown           | Brown    | Brown    |
| 12           | M39029/4-113       | BA-4012-36LD         | Brown           | Brown    | Orange   |

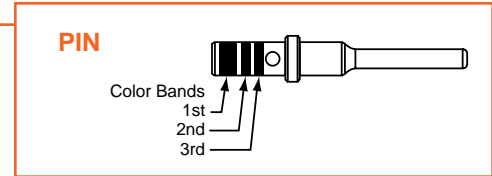

### STANDARD CRIMP CONTACTS - SOCKET PART NUMBERS / COLOR BANDS

| Contact Size | Socket MS Spec Number | Socket Pyle Part Number | Socket Color Bands |          |          |
|--------------|-----------------------|-------------------------|--------------------|----------|----------|
|              |                       |                         | 1st Band           | 2nd Band | 3rd Band |
| 20           | M39029/5-115          | BA-4120-36LD            | Brown              | Brown    | Green    |
| 16           | M39029/5-116          | BA-4116-36LD            | Brown              | Brown    | Blue     |
| 12           | M39029/5-118          | BA-4112-36LD            | Brown              | Brown    | Gray     |

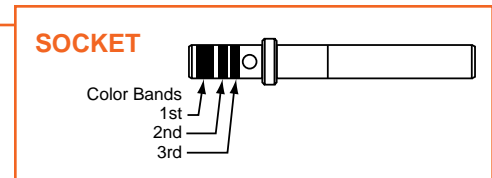

Sockets feature 4 tine construction with supporting spring bands.

### STANDARD CRIMP CONTACT RATING

| Contact Size | Test Current Standard | Crimp Well Data |             |                 |             |
|--------------|-----------------------|-----------------|-------------|-----------------|-------------|
|              |                       | Well Diameter   |             | Min. Well Depth |             |
|              |                       | Inches          | Millimeters | Inches          | Millimeters |
| 20           | 7.5                   | .049            | 1.25        | .157            | 3.99        |
| 16           | 13.0                  | .067            | 1.70        | .250            | 6.35        |
| 12           | 23.0                  | .100            | 2.54        | .250            | 6.35        |

### STANDARD SEALING PLUGS

| Contact Size | Sealing Plug MS Number | Sealing Plug Pyle Number | Color  |
|--------------|------------------------|--------------------------|--------|
| 20           | MS27488-20             | BA-4020-59P              | Red    |
| 16           | MS27488-16             | BA-4016-59P              | Blue   |
| 12           | MS27488-12             | BA-4012-59P              | Yellow |

### TOOLS

| Contact Size | Crimp Tool  |             | Adjustable Turret |             | Checking Gauge for M22520/1-01 Crimping Tool |             | Insertion/Removal Tool |                 |                  |
|--------------|-------------|-------------|-------------------|-------------|--|-------------|------------------------|-----------------|------------------|
|              | MS Number   | Pyle Number | MS Number         | Pyle Number | MS Number                                    | Pyle Number | MS Number              | Pyle Number     | Amphenol Number* |
| 20           | M22520/1-01 | TP-201354   | M22520/1-02       | TP-201355   | M22520/3                                     | TP-201356   | M81969/14-11           | TP-201343-20-BA | 10-538988-201    |
| 16           |             |             |                   |             |  |             | M81969/14-03           | TP-201343-16-BA | 10-538988-016    |
| 12           |             |             |                   |             |  |             | M81969/14-04           | TP-201343-12-BA | 10-538988-012    |

\* Amphenol part number for insertion/removal tool supersedes Pyle number

# MIL-DTL-83723, Series III, Pyle®

## Shielded Contacts, Thermocouple Contacts, Wire Sealing Information

### SHIELDED CONCENTRIC TWINAX CONTACTS

| Contact Size | Cable Accommodation     | Concentric Twinax Pin |
|--------------|-------------------------|-----------------------|
| #8 Twinax    | M17/176-00002           | BA-46T08-LD           |
| #8 Twinax    | PAN 6421 or JN1060ZB002 | BA-46TA08-LD          |

**CONCENTRIC TWINAX PIN**

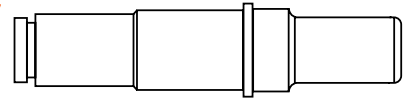

Non-MS part; no color bands.

| Contact Size | Cable Accommodation     | Concentric Twinax Socket |
|--------------|-------------------------|--------------------------|
| #8 Twinax    | M17/176-00002           | BA-47T08-LD              |
| #8 Twinax    | PAN 6421 or JN1060ZB002 | BA-47TA08-LD             |

**CONCENTRIC TWINAX SOCKET**

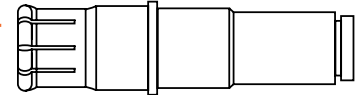

Non-MS part; no color bands.

Concentric Twinax contacts are designed for protection from magnetic and electrostatic interference including nuclear electromagnetic pulse. Consult Amphenol for other size twinax and coax contacts available for use in MIL-DTL-83723, Series III Pyle connectors.

### THERMOCOUPLE - PIN PART NUMBERS / COLOR BANDS

| Contact Size | Material | Thermocouple Pin Pyle Part Number | Thermocouple Pin Color Bands |          |          |
|--------------|----------|-----------------------------------|------------------------------|----------|----------|
|              |          |                                   | 1st Band                     | 2nd Band | 3rd Band |
| 20           | Chromel  | BT-4020-10P                       | Brown                        | Orange   | Green    |
| 20           | Alumel   | BT-4020-10R                       | Brown                        | Orange   | Yellow   |
| 16           | Chromel  | BA-4016-10P                       | Green                        | Brown    | Violet   |
| 16           | Alumel   | BA-4016-10R                       | Green                        | Brown    | Blue     |

### THERMOCOUPLE - SOCKET PART NUMBERS / COLOR BANDS

| Contact Size | Material | Thermocouple Socket Pyle Part Number | Thermocouple Socket MS Part Number | Thermocouple Socket Color Bands |          |          |
|--------------|----------|--------------------------------------|------------------------------------|---------------------------------|----------|----------|
|              |          |                                      |                                    | 1st Band                        | 2nd Band | 3rd Band |
| 20           | Chromel  | BT-4120-10P                          | –                                  | Brown                           | Yellow   | Brown    |
| 20           | Alumel   | BT-4120-10R                          | –                                  | Brown                           | Yellow   | Black    |
| 16           | Chromel  | BT-4116-10P                          | M39029/10-522                      | Green                           | Red      | Red      |
| 16           | Alumel   | BT-4116-10R                          | M39029/10-521                      | Green                           | Red      | Brown    |

### STANDARD & HIGH TEMPERATURE CRIMP CONTACTS WIRE SEALING DIAMETERS / STRIPPING LENGTHS

| Contact Size | Wire Size (AWG) | Finished Wire Outside |             |         |             | Stripping Lengths |             |         |             |
|--------------|-----------------|-----------------------|-------------|---------|-------------|-------------------|-------------|---------|-------------|
|              |                 | Minimum               |             | Maximum |             | Minimum           |             | Maximum |             |
|              |                 | Inches                | Millimeters | Inches  | Millimeters | Inches            | Millimeters | Inches  | Millimeters |
| 20           | 24, 22, 20      | .033                  | .84         | .083    | 2.11        | .140              | 3.56        | .202    | 5.13        |
| 16           | 20, 18, 16      | .047                  | 1.19        | .106    | 2.69        | .218              | 5.54        | .280    | 7.11        |
| 12           | 14, 12          | .075                  | 1.91        | .157    | 3.99        | .218              | 5.54        | .280    | 7.11        |

III  
II  
I  
SJT  
38999

Matrix 2  
26482

Matrix Pyle  
83723 III

Release Matrix  
5015  
Crimp Rear

26500 Pyle

Printed  
Circuit Board

EMI Filter  
Transient

Fiber Optics

High Speed  
Contacts

Options  
Others

38999  
SJT I II III

26482  
Matrix 2

83723 III  
Matrix Pyle

5015  
Crimp Rear  
Release Matrix

26500 Pyle

Printed  
Circuit Board

EMI Filter  
Transient

Fiber Optics

High Speed  
Contacts

Options  
Others

**CONTACTS THAT MEET EUROPEAN SPECIFICATIONS  
STANDARD CRIMP - PIN  
PART NUMBERS / COLOR BANDS**

| Contact Size | Pin Pyle Part Number | Pin EN3155 Part Number | Pin Color Bands |          |     |
|--------------|----------------------|------------------------|-----------------|----------|-----|
|              |                      |                        | 1st Band        | 2nd Band | Dot |
| 20           | BA-4020-36LD-Y165    | EN3155-002MM2020       | Red             | Red      | -   |
| 20/18*       | BA-402018-36LD-Y165  | EN3155-002M2018        | Red             | Violet   | -   |
| 16           | BA-4016-36LD-Y165    | EN3155-002M1616        | Blue            | Blue     | -   |
| 12           | BA-4012-36LD-Y165    | EN3155-002M1212        | Yellow          | Yellow   | -   |

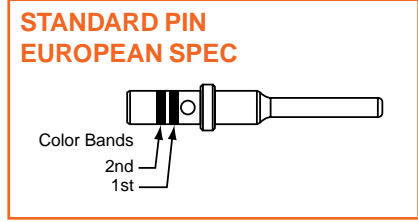

First band color is for contact size  
2nd band color is for AWG wire size

**CONTACTS THAT MEET EUROPEAN SPECIFICATIONS  
STANDARD CRIMP - SOCKET  
PART NUMBERS / COLOR BANDS**

| Contact Size | Socket Pyle Part Number | Socket EN3155 Part Number | Socket Color Bands |          |     |
|--------------|-------------------------|---------------------------|--------------------|----------|-----|
|              |                         |                           | 1st Band           | 2nd Band | Dot |
| 20           | BA-4120-36LD-Y165       | EN3155-003F2020           | Red                | Red      | -   |
| 20/18*       | BA-412018-36LD-Y165     | EN3155-003F2018           | Red                | Violet   | -   |
| 16           | BA-4116-36LD-Y165       | EN3155-003F1616           | Blue               | Blue     | -   |
| 12           | BA-4112-36LD-Y165       | EN3155-003F1212           | Yellow             | Yellow   | -   |

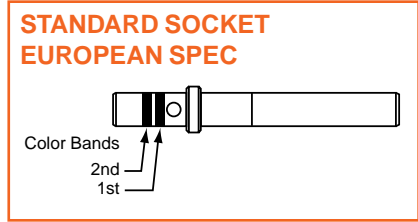

First band color is for contact size  
2nd band color is for AWG wire size

**CONTACTS THAT MEET EUROPEAN SPECIFICATIONS  
HIGH TEMPERATURE - PIN  
PART NUMBERS / COLOR BANDS**

| Contact Size | Pin Pyle Part Number | Pin ESC30 Part Number | Pin EN3155 Part Number | Pin Color Bands |          |       |
|--------------|----------------------|-----------------------|------------------------|-----------------|----------|-------|
|              |                      |                       |                        | 1st Band        | 2nd Band | Dot   |
| 20           | BA-4020-50LD         | ESC30-P20BC           | EN3155-004M2020        | Red             | Red      | White |
| 20/18*       | BA-402018-50LD       | -                     | EN3155-004M2018        | Red             | Violet   | White |
| 16           | BA-4016-50LD         | ESC30-P16BC           | EN3155-004M1616        | Blue            | Blue     | White |
| 12           | BA-4012-50LD         | ESC30-P12BC           | EN3155-004M1212        | Yellow          | Yellow   | White |

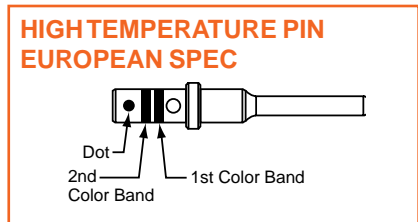

First band color is for contact size  
2nd band color is for AWG wire size  
Dot identifies High Temperature or Thermocouple contacts

**CONTACTS THAT MEET EUROPEAN SPECIFICATIONS  
HIGH TEMPERATURE - SOCKET  
PART NUMBERS / COLOR BANDS**

| Contact Size | Socket Pyle Part Number | Socket ESC30 Part Number | Socket EN3155 Part Number | Socket Color Bands |          |       |
|--------------|-------------------------|--------------------------|---------------------------|--------------------|----------|-------|
|              |                         |                          |                           | 1st Band           | 2nd Band | Dot   |
| 20           | BA-4120-50LD            | ESC30-S20BC              | EN3155-005M2020           | Red                | Red      | White |
| 20/18*       | BA-412018-50LD          | -                        | EN3155-005M2018           | Red                | Violet   | White |
| 16           | BA-4116-50LD            | ESC30-S16BC              | EN3155-005M1616           | Blue               | Blue     | White |
| 12           | BA-4112-50LD            | ESC30-S12BC              | EN3155-005M1212           | Yellow             | Yellow   | White |

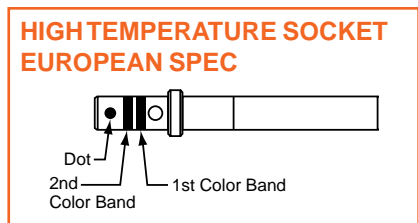

First band color is for contact size  
2nd band color is for AWG wire size  
Dot identifies High Temperature or Thermocouple contacts

\* #20 contacts with #18 crimpwell

### CONTACTS THAT MEET EUROPEAN SPECIFICATIONS THERMOCOUPLE - PIN PART NUMBERS / COLOR BANDS

| Contact Size | Material | Pin Pyle Part Number | Pin ESC30 Part Number | Pin Color Bands |          |        |
|--------------|----------|----------------------|-----------------------|-----------------|----------|--------|
|              |          |                      |                       | 1st Band        | 2nd Band | Dot    |
| 20           | Chromel  | BT-4020-10P-Y165     | ESC30-P20NC           | Red             | Red      | Yellow |
| 20           | Alumel   | BT-4020-10R-Y165     | ESC30-P20NA           | Red             | Red      | Black  |
| 20/18*       | Chromel  | BT-402018-10P-Y165   | -                     | Red             | Violet   | Yellow |
| 20/18*       | Alumel   | BT-402018-10R-Y165   | -                     | Red             | Violet   | Black  |
| 16           | Chromel  | BT-4016-10P-Y165     | ESC30-P16NC           | Blue            | Blue     | Yellow |
| 16           | Alumel   | BT-4016-10R-Y165     | ESC30-P16NA           | Blue            | Blue     | Black  |

### CONTACTS THAT MEET EUROPEAN SPECIFICATIONS THERMOCOUPLE - SOCKET PART NUMBERS / COLOR BANDS

| Contact Size | Material | Socket Pyle Part Number | Socket ESC30 Part Number | Socket Color Bands |          |        |
|--------------|----------|-------------------------|--------------------------|--------------------|----------|--------|
|              |          |                         |                          | 1st Band           | 2nd Band | Dot    |
| 20           | Chromel  | BT-4120-10P-Y165        | ESC30-S20NC              | Red                | Red      | Yellow |
| 20           | Alumel   | BT-4120-10R-Y165        | ESC30-S20NA              | Red                | Red      | Black  |
| 20/18*       | Chromel  | BT-412018-10P-Y165      | -                        | Red                | Violet   | Yellow |
| 20/18*       | Alumel   | BT-412018-10R-Y165      | -                        | Red                | Violet   | Black  |
| 16           | Chromel  | BT-4116-10P-Y165        | ESC30-S16NC              | Blue               | Blue     | Yellow |
| 16           | Alumel   | BT-4116-10R-Y165        | ESC30-S16NA              | Blue               | Blue     | Black  |

### HIGH TEMPERATURE SEALING PLUGS

| Contact Size | Sealing Plug Pyle Number | Color  |
|--------------|--------------------------|--------|
| 20           | BT-4020-60P              | Red    |
| 16           | BT-4016-60P              | Blue   |
| 12           | BT-4012-60P              | Yellow |

III  
II  
I  
SJT  
38999

26482  
Matrix 2

83723 III  
Matrix Pyle

5015  
Crimp Rear  
Release Matrix

26500 Pyle

Printed  
Circuit Board

EMI Filter  
Transient

Fiber Optics

High Speed  
Contacts

Options  
Others

# Amphenol MIL-DTL-5015, Matrix<sup>®</sup>



**New  
Featured**



## TABLE OF CONTENTS

### MIL-DTL-5015, Matrix<sup>®</sup>

- Table of Contents . . . . . 170
- Design Characteristics, Customer Options . . . . . 171
- Insert Availability and Identification . . . . . 172, 173
- Insert Arrangement Drawings . . . . . 174 - 182
- Class Descriptions, Performance Specifications . . . . . 183
- Insert Alternate Positioning . . . . . 184
- How to Order, Military and Commercial . . . . . 185

### Shell Styles:

- Wall mounting receptacle threaded MS3450 (9440) . . . . . 186
- Cable connecting plug threaded MS3451 (9441) . . . . . 187
- Box mounting receptacle threaded MS3452 (9442) . . . . . 188
- Jam nut receptacle threaded MS3454 (9444) . . . . . 189
- Straight plug threaded MS3456 (9446) . . . . . 190
- Straight plug, self-locking threaded MS3459 (9816) . . . . . 191
- Quick disconnect plug push-pull coupling (9817/9818) . . . . . 192
- Matrix<sup>®</sup> 5015 with RADSOK<sup>®</sup> contacts, for high power . . . . . 193
- Contact information, sealing plugs, tools . . . . . 194
- Protection caps, dust caps . . . . . 195-197
- Additional MIL-DTL-5015 connectors offered by Amphenol . . . . . 198



### MIL-DTL-5015, Matrix<sup>®</sup> Typical Markets:

- Military Vehicles
- Heavy Equipment
- Military Aircraft
- Power Generation

**Amphenol**  
Aerospace



III  
II  
I  
SJT

38999

Matrix 2

26482

Matrix  
Pyle

83723 III

5015  
Crimp Rear  
Release Matrix

26500 Pyle

Printed  
Circuit Board

EMI Filter  
Transient

Fiber Optics

High Speed  
Contacts

Options  
Others



**Amphenol broadens their MS/Standard family of connectors with the MIL-DTL-5015 Crimp Rear Release Series.**

This series provides an alternative to the older MIL-C-5015 solder type. It bridges the gap between an old connector standard and the environmental and high performance needs of current technologies.

**DESIGN CHARACTERISTICS**

- Medium to heavy weight cylindrical
- MS345( ) series intermateable with existing MIL-DTL-5015 solder or crimp versions on existing equipment
- Captive coupling nut mechanism, utilizes retaining rings in combination with "L" washers to prevent inadvertent disassembly
- Multiple interlock systems ensure permanent insert retention
- Positive control of dielectric separation with guaranteed ease of contact insertion
- Positive contact retention provided by a closely toleranced damage-proof metal retention clip
- Completely sealed against environmental extremes with -
  - Individual contact seals (conical risers on pin interface)
  - Interfacial seals between contacts
  - Peripheral gasket shell-to-shell seals
  - Redundant rear wire seals and insert-to-shell seals

**CUSTOMER OPTIONS**

- Seven mounting styles, in shell sizes 8 to 48\*
- Threaded coupling or self-locking plug (MS3459) with an internal ratcheting mechanism to prevent unmating due to vibration and shock, eliminating the need for safety wiring
- Proprietary quick disconnect plug, with or without lanyard available
- Classes include aluminum or stainless steel shells, or firewall capability
- MS and Proprietary versions available
- Some styles are supplied to McDonnell Douglas Specification BAN 7025, DC60 Series
- Accommodation of contact sizes 0 to 16
- Over 100 insert arrangement patterns available, accommodating from a minimum of 1 to a maximum of 85 circuits
- Alternate positioning available
- Thermocouple pin and socket contacts are available\*\*

NOTE: MIL-C-5015 is superseded to MIL-DTL-5015 for all Amphenol/Matrix rear release crimp type contacts.

\* Consult Amphenol, Sidney, NY for availability of shell sizes 44 and 48.

\*\* Consult Amphenol, Sidney, NY for information on thermocouple contacts.



- 38999  
SJT I II III
- 26482  
Matrix 2
- 83723 III  
Matrix Pyle
- 5015  
Crimp Rear Release Matrix
- 26500 Pyle
- Printed  
Circuit Board
- EMI Filter  
Transient
- Fiber Optics
- High Speed  
Contacts
- Options  
Others

| Insert Arrangement | Service Rating | Total Contacts | Contact Size |   |   |    |    |
|--------------------|----------------|----------------|--------------|---|---|----|----|
|                    |                |                | 0            | 4 | 8 | 12 | 16 |
| 8S-1               | A              | 1              |              |   |   |    | 1  |
| 10S-2              | A              | 1              |              |   |   |    | 1  |
| 10SL-3             | A              | 3              |              |   |   |    | 3  |
| 10SL-4             | A              | 2              |              |   |   |    | 2  |
| 12S-1              | A              | 2              |              |   |   |    | 2  |
| 12S-2              | A              | 2              |              |   |   |    | 2  |
| 12S-3              | A              | 2              |              |   |   |    | 2  |
| 12S-4              | D              | 1              |              |   |   |    | 1  |
| 12-5               | D              | 1              |              |   |   | 1  |    |
| 14S-1**            | A              | 3              |              |   |   |    | 3  |
| 14S-2              | Inst.          | 4              |              |   |   |    | 4  |
| 14-3               | A              | 1              |              |   | 1 |    |    |
| 14S-5              | Inst.          | 5              |              |   |   |    | 5  |
| 14S-6              | Inst.          | 6              |              |   |   |    | 6  |
| 14S-7              | A              | 3              |              |   |   |    | 3  |
| 14S-9**            | A              | 2              |              |   |   |    | 2  |
| 14S-10             | Inst.          | 4              |              |   |   |    | 4  |
| 14S-11             | Inst.          | 4              |              |   |   |    | 4  |
| 14S-12             | A              | 3              |              |   |   |    | 3  |
| 14S-13             | A              | 3              |              |   |   |    | 3  |
| 16S-1              | A              | 7              |              |   |   |    | 7  |
| 16-2*              | E              | 1              |              |   |   | 1  |    |
| 16S-3*             | B              | 1              |              |   |   |    | 1  |
| 16S-4*             | D              | 2              |              |   |   |    | 2  |
| 16-7*              | A              | 3              |              |   | 1 |    | 2  |
| 16S-8              | A              | 5              |              |   |   |    | 5  |
| 16-9               | A              | 4              |              |   |   | 2  | 2  |
| 16-10              | A              | 3              |              |   |   | 3  |    |
| 16-11              | A              | 2              |              |   |   | 2  |    |
| 16-12              | A              | 1              |              | 1 |   |    |    |
| 16-13              | A              | 2              |              |   |   | 2  |    |
| 18-1               | A/Inst.        | 10             |              |   |   |    | 10 |
| 18-4               | D              | 4              |              |   |   |    | 4  |
| 18-5•              | D              | 3              |              |   |   | 2  | 1  |
| 18-6*              | D              | 1              |              | 1 |   |    |    |
| 18-7*              | B              | 1              |              |   | 1 |    |    |
| 18-8               | A              | 8              |              |   |   | 1  | 7  |
| 18-9               | Inst.          | 7              |              |   |   | 2  | 5  |
| 18-10**            | A              | 4              |              |   |   | 4  |    |
| 18-11              | A              | 5              |              |   |   | 5  |    |
| 18-12              | A              | 6              |              |   |   |    | 6  |
| 18-13              | A              | 4              |              |   | 1 | 3  |    |
| 18-14*             | A              | 2              |              | 1 |   |    | 1  |
| 18-15              | A              | 4              |              |   |   | 4  |    |
| 18-16*             | C              | 1              |              |   |   | 1  |    |
| 18-17              | Inst.          | 7              |              |   |   | 2  | 5  |
| 18-18              | Inst.          | 7              |              |   |   | 2  | 5  |
| 18-19**            | A              | 10             |              |   |   |    | 10 |
| 18-22**            | D              | 3              |              |   |   |    | 3  |

| Insert Arrangement | Service Rating | Total Contacts | Contact Size |   |   |    |    |
|--------------------|----------------|----------------|--------------|---|---|----|----|
|                    |                |                | 0            | 4 | 8 | 12 | 16 |
| 18-23              | A/Inst.        | 10             |              |   |   |    | 10 |
| 18-24              | A/Inst.        | 10             |              |   |   |    | 10 |
| 18-27•             | D              | 3              |              |   |   | 2  | 1  |
| 18-28•             | D              | 3              |              |   |   | 2  | 1  |
| 20-2               | D              | 1              | 1            |   |   |    |    |
| 20-4               | D              | 4              |              |   |   | 4  |    |
| 20-7               | D/A            | 8              |              |   |   |    | 8  |
| 20-8               | Inst.          | 6              |              |   |   | 2  | 4  |
| 20-9*              | D/A            | 8              |              |   |   | 1  | 7  |
| 20-14              | A              | 5              |              |   |   | 2  | 3  |
| 20-15              | A              | 7              |              |   |   | 7  |    |
| 20-16              | A              | 9              |              |   |   | 2  | 7  |
| 20-17              | A              | 6              |              |   |   | 5  | 1  |
| 20-18              | A              | 9              |              |   |   | 3  | 6  |
| 20-19              | A              | 3              |              |   |   | 3  |    |
| 20-21              | A              | 9              |              |   |   | 1  | 8  |
| 20-22              | A              | 6              |              |   |   | 3  | 3  |
| 20-24              | A              | 4              |              |   |   | 2  | 2  |
| 20-27              | A              | 14             |              |   |   |    | 14 |
| 20-29              | A              | 17             |              |   |   |    | 17 |
| 20-32              | D/A            | 8              |              |   |   |    | 8  |
| 20-33              | A              | 11             |              |   |   |    | 11 |
| 22-2               | D              | 3              |              |   |   | 3  |    |
| 22-4**             | A              | 4              |              |   |   | 2  | 2  |
| 22-5               | D              | 6              |              |   |   | 2  | 4  |
| 22-6*              | D              | 3              |              |   |   | 2  | 1  |
| 22-7*              | E              | 1              | 1            |   |   |    |    |
| 22-9*              | E              | 3              |              |   |   | 3  |    |
| 22-10*             | E              | 4              |              |   |   |    | 4  |
| 22-11*             | B              | 2              |              |   |   |    | 2  |
| 22-12*             | D              | 5              |              |   |   | 2  | 3  |
| 22-14              | A              | 19             |              |   |   |    | 19 |
| 22-15*             | E/A            | 6              |              |   |   | 5  | 1  |
| 22-17*             | D/A            | 9              |              |   |   | 1  | 8  |
| 22-18*             | D/A            | 8              |              |   |   |    | 8  |
| 22-19              | A              | 14             |              |   |   |    | 14 |
| 22-21              | A              | 3              | 1            |   |   |    | 2  |
| 22-22              | A              | 4              |              |   |   | 4  |    |
| 22-23              | D/A            | 8              |              |   |   | 8  |    |
| 22-27*             | D/A            | 9              |              |   |   | 1  | 8  |
| 22-30              | A              | 19             |              |   |   |    | 19 |
| 22-32              | D              | 6              |              |   |   | 2  | 4  |
| 22-36*             | D/A            | 8              |              |   |   | 8  |    |
| 24-1**             | D              | 2              | 1            |   |   | 1  |    |
| 24-2               | D              | 7              |              |   |   | 7  |    |
| 24-4*              | D              | 4              | 1            |   |   |    | 3  |
| 24-5**             | A              | 16             |              |   |   |    | 16 |
| 24-6*              | D/A            | 8              |              |   |   | 8  |    |

\* Consult Amphenol, Sidney, NY for availability

\*\* Inactive for new design

• Socket Only

# MIL-DTL-5015 Crimp Rear Release

## Insert Availability and Identification



| Insert Arrangement | Service Rating | Total Contacts | Contact Size |   |   |    |    |
|--------------------|----------------|----------------|--------------|---|---|----|----|
|                    |                |                | 0            | 4 | 8 | 12 | 16 |
| 24-7               | A              | 16             |              |   |   | 2  | 14 |
| 24-10              | A              | 7              |              |   | 7 |    |    |
| 24-11              | A              | 9              |              |   | 3 | 6  |    |
| 24-12              | A              | 5              |              | 2 |   | 3  |    |
| 24-15              | A              | 16             |              |   |   |    | 16 |
| 24-16*             | D/A            | 7              |              |   | 1 | 3  | 3  |
| 24-20              | D              | 11             |              |   |   | 2  | 9  |
| 24-21*             | D              | 10             |              |   | 1 |    | 9  |
| 24-22              | D              | 4              |              |   | 4 |    |    |
| 24-24              | A              | 16             |              |   |   |    | 16 |
| 24-27*             | E              | 7              |              |   |   |    | 7  |
| 24-28              | Inst.          | 24             |              |   |   |    | 24 |
| 24-80*             | Inst.          | 23             |              |   |   |    | 23 |
| 28-1               | D/A            | 9              |              |   | 3 | 6  |    |
| 28-2               | D              | 14             |              |   |   | 2  | 12 |
| 28-3*              | E              | 3              |              |   | 3 |    |    |
| 28-4*              | E/D            | 9              |              |   |   | 2  | 7  |
| 28-5*              | D              | 5              |              | 2 |   | 1  | 2  |
| 28-8*              | E/D/A          | 12             |              |   |   | 2  | 10 |
| 28-9               | D              | 12             |              |   |   | 6  | 6  |
| 28-10              | D/A            | 7              |              | 2 | 2 | 3  |    |
| 28-11              | A              | 22             |              |   |   | 4  | 18 |
| 28-12              | A              | 26             |              |   |   |    | 26 |
| 28-13              | A              | 26             |              |   |   |    | 26 |
| 28-15              | A              | 35             |              |   |   |    | 35 |
| 28-16*             | A              | 20             |              |   |   |    | 20 |
| 28-17              | B/D/A          | 15             |              |   |   |    | 15 |
| 28-18*             | C/D/A/Inst.    | 12             |              |   |   |    | 12 |
| 28-19*             | B/D/A          | 10             |              |   |   | 4  | 6  |
| 28-20              | A              | 14             |              |   |   | 10 | 4  |
| 28-21              | A              | 37             |              |   |   |    | 37 |
| 28-22              | D              | 6              |              | 3 |   |    | 3  |
| 32-1               | E/D            | 5              | 2            |   |   | 3  |    |
| 32-2*              | E              | 5              |              | 3 |   |    | 2  |
| 32-3*              | D              | 9              | 1            | 2 |   | 2  | 4  |
| 32-6               | A              | 23             |              | 2 | 3 | 2  | 16 |
| 32-7               | Inst./A        | 35             |              |   |   | 7  | 28 |
| 32-9               | D              | 14             |              | 2 |   |    | 12 |
| 32-13              | D              | 23             |              |   |   | 5  | 18 |
| 32-15              | D              | 8              | 2            |   |   | 6  |    |
| 32-16              | A              | 23             |              | 2 | 3 | 2  | 16 |
| 32-17              | D              | 4              |              | 4 |   |    |    |
| 32-19              | E/D            | 5              | 2            |   |   | 3  |    |
| 32-20              | A              | 23             |              | 2 | 3 | 2  | 16 |

| Insert Arrangement | Service Rating | Total Contacts | Contact Size |   |   |    |    |
|--------------------|----------------|----------------|--------------|---|---|----|----|
|                    |                |                | 0            | 4 | 8 | 12 | 16 |
| 32-22*             | A              | 54             |              |   |   |    | 54 |
| 32-63              | D              | 5              |              | 5 |   |    |    |
| 32-73              | A              | 46             |              |   |   |    | 46 |
| 36-3               | D              | 6              | 3            |   |   | 3  |    |
| 36-5               | A              | 4              | 4            |   |   |    |    |
| 36-6               | A              | 6              | 2            | 4 |   |    |    |
| 36-7               | A              | 47             |              |   |   | 7  | 40 |
| 36-8               | A              | 47             |              |   |   | 1  | 46 |
| 36-9               | A              | 31             |              | 1 | 2 | 14 | 14 |
| 36-10              | A              | 48             |              |   |   |    | 48 |
| 36-11              | A              | 48             |              |   |   |    | 48 |
| 36-12              | A              | 48             |              |   |   |    | 48 |
| 36-15              | D/A            | 35             |              |   |   |    | 35 |
| 36-16              | A              | 47             |              |   |   | 7  | 40 |
| 36-17              | A              | 47             |              |   |   | 7  | 40 |
| 36-18              | A              | 31             |              | 1 | 2 | 14 | 14 |
| 36-21              | A              | 31             |              | 1 | 2 | 14 | 14 |
| 36-52              | A              | 52             |              |   |   |    | 52 |
| 36-66*             | A              | 56             |              |   |   | 4  | 52 |
| 40-1               | D              | 30             |              |   |   | 6  | 24 |
| 40-2*              | D              | 23             |              |   |   |    | 23 |
| 40-3*              | D              | 23             |              | 1 |   | 4  | 18 |
| 40-4*              | D              | 23             |              | 2 | 3 | 2  | 16 |
| 40-5*              | A              | 15             | 3            | 2 | 4 | 6  |    |
| 40-6*              | D              | 26             | 1            |   |   | 1  | 24 |
| 40-7*              | A/D            | 22             | 2            |   |   | 2  | 18 |
| 40-9               | A              | 47             |              |   | 1 | 22 | 24 |
| 40-10*             | A              | 29             |              | 4 | 9 |    | 16 |
| 40-11*             | D              | 25             | 1            | 1 | 1 | 4  | 18 |
| 40-56              | A              | 85             |              |   |   |    | 85 |
| 40-62*             | A              | 60             |              |   |   |    | 60 |

\* Consult Amphenol, Sidney, NY for availability  
 \*\* Inactive for new design

III  
II  
I  
SJT  
38999

Matrix 2  
26482

Matrix Pyle  
83723 III

Release Matrix  
Crimp Rear  
5015

Pyle  
26500

Printed  
Circuit Board

EMI Filter  
Transient

Fiber Optics

High Speed  
Contacts

Options  
Others

Front Face of Pin Insert or Rear Face of Socket Insert Illustrated

38999  
SJT I II III

26482  
Matrix 2

83723 III  
Matrix Pyle

5015  
Crimp Rear  
Release Matrix

26500 Pyle

Printed  
Circuit Board

EMI Filter  
Transient

Fiber Optics

High Speed  
Contacts

Options  
Others



|                           |      |       |        |        |       |       |       |
|---------------------------|------|-------|--------|--------|-------|-------|-------|
| <b>Insert Arrangement</b> | 8S-1 | 10S-2 | 10SL-3 | 10SL-4 | 12S-1 | 12S-2 | 12S-3 |
| <b>Service Rating</b>     | A    | A     | A***   | A      | A     | A     | A     |
| <b>Number of Contacts</b> | 1    | 1     | 3      | 2      | 2     | 2     | 2     |
| <b>Contact Size</b>       | 16   | 16    | 16     | 16     | 16    | 16    | 16    |



|                           |       |      |         |       |      |       |       |
|---------------------------|-------|------|---------|-------|------|-------|-------|
| <b>Insert Arrangement</b> | 12S-4 | 12-5 | 14S-1** | 14S-2 | 14-3 | 14S-5 | 14S-6 |
| <b>Service Rating</b>     | D     | D    | A       | Inst. | A    | Inst. | Inst. |
| <b>Number of Contacts</b> | 1     | 1    | 3       | 4     | 1    | 5     | 6     |
| <b>Contact Size</b>       | 16    | 12   | 16      | 16    | 8    | 16    | 16    |

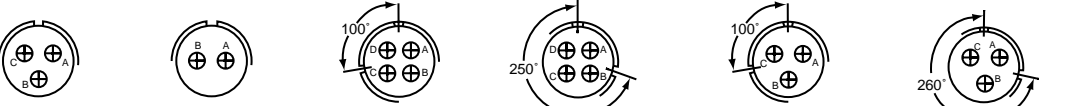

|                           |       |         |        |        |        |        |
|---------------------------|-------|---------|--------|--------|--------|--------|
| <b>Insert Arrangement</b> | 14S-7 | 14S-9** | 14S-10 | 14S-11 | 14S-12 | 14S-13 |
| <b>Service Rating</b>     | A     | A       | Inst.  | Inst.  | A      | A      |
| <b>Number of Contacts</b> | 3     | 2       | 4      | 4      | 3      | 3      |
| <b>Contact Size</b>       | 16    | 16      | 16     | 16     | 16     | 16     |

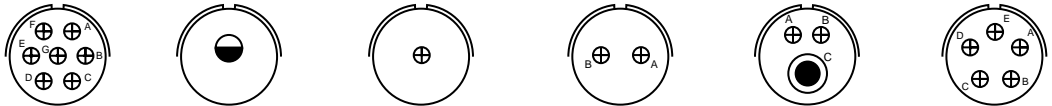

|                           |       |       |        |        |       |       |
|---------------------------|-------|-------|--------|--------|-------|-------|
| <b>Insert Arrangement</b> | 16S-1 | 16-2* | 16S-3* | 16S-4* | 16-7* | 16S-8 |
| <b>Service Rating</b>     | A     | E     | B      | D      | A     | A     |
| <b>Number of Contacts</b> | 7     | 1     | 1      | 2      | 1 2   | 5     |
| <b>Contact Size</b>       | 16    | 12    | 16     | 16     | 8 16  | 16    |



|                           |       |       |       |       |       |                              |
|---------------------------|-------|-------|-------|-------|-------|------------------------------|
| <b>Insert Arrangement</b> | 16-9  | 16-10 | 16-11 | 16-12 | 16-13 | 18-1                         |
| <b>Service Rating</b>     | A     | A     | A     | A     | A     | B, C, F, G = A; Bal. = Inst. |
| <b>Number of Contacts</b> | 2 2   | 3     | 2     | 1     | 2†    | 10                           |
| <b>Contact Size</b>       | 12 16 | 12    | 12    | 4     | 12    | 16                           |

\* Consult Amphenol, Sidney, NY for availability.  
 \*\* Inactive for new design  
 \*\*\* Service rating Inst. Class K  
 † one Iron contact and one Constantan contact

CONTACT LEGEND

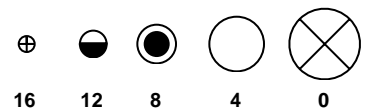

# MIL-DTL-5015 Crimp Rear Release Insert Arrangements

Front Face of Pin Insert or Rear Face of Socket Insert Illustrated

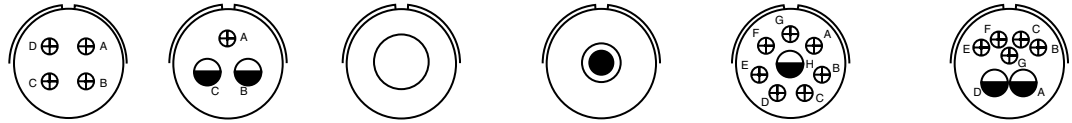

|                           |             |               |    |              |              |              |    |             |    |
|---------------------------|-------------|---------------|----|--------------|--------------|--------------|----|-------------|----|
| <b>Insert Arrangement</b> | <b>18-4</b> | <b>18-5 •</b> |    | <b>18-6*</b> | <b>18-7*</b> | <b>18-8*</b> |    | <b>18-9</b> |    |
| <b>Service Rating</b>     | D           | D             |    | D            | B            | A            |    | Inst.       |    |
| <b>Number of Contacts</b> | 4           | 2             | 1  | 1            | 1            | 1            | 7  | 2           | 5  |
| <b>Contact Size</b>       | 16          | 12            | 16 | 4            | 8            | 12           | 16 | 12          | 16 |

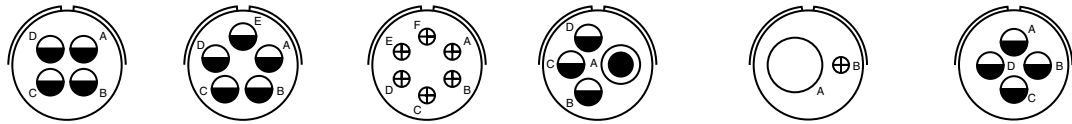

|                           |                |              |  |              |              |    |               |    |              |
|---------------------------|----------------|--------------|--|--------------|--------------|----|---------------|----|--------------|
| <b>Insert Arrangement</b> | <b>18-10**</b> | <b>18-11</b> |  | <b>18-12</b> | <b>18-13</b> |    | <b>18-14*</b> |    | <b>18-15</b> |
| <b>Service Rating</b>     | A              | A            |  | A            | A            |    | A             |    | A            |
| <b>Number of Contacts</b> | 4              | 5            |  | 6            | 1            | 3  | 1             | 1  | 4††          |
| <b>Contact Size</b>       | 12             | 12           |  | 16           | 8            | 12 | 4             | 16 | 12           |

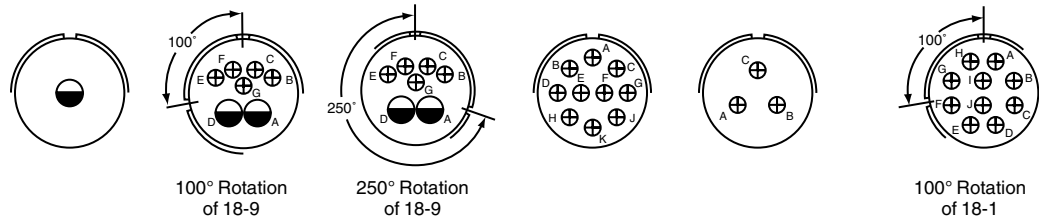

|                           |               |              |    |              |    |                |                |                              |  |
|---------------------------|---------------|--------------|----|--------------|----|----------------|----------------|------------------------------|--|
| <b>Insert Arrangement</b> | <b>18-16*</b> | <b>18-17</b> |    | <b>18-18</b> |    | <b>18-19**</b> | <b>18-22**</b> | <b>18-23</b>                 |  |
| <b>Service Rating</b>     | C             | Inst.        |    | Inst.        |    | A              | D              | B, C, F, G = A; Bal. = Inst. |  |
| <b>Number of Contacts</b> | 1             | 2            | 5  | 2            | 5  | 10             | 3              | 10                           |  |
| <b>Contact Size</b>       | 12            | 12           | 16 | 12           | 16 | 16             | 16             | 16                           |  |

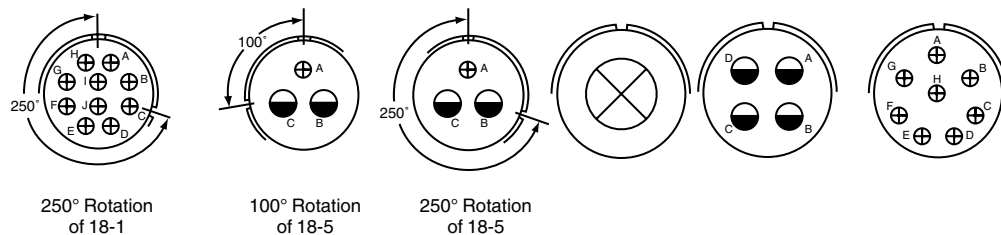

|                           |                              |                |    |                |    |             |             |                                |  |
|---------------------------|------------------------------|----------------|----|----------------|----|-------------|-------------|--------------------------------|--|
| <b>Insert Arrangement</b> | <b>18-24</b>                 | <b>18-27 •</b> |    | <b>18-28 •</b> |    | <b>20-2</b> | <b>20-4</b> | <b>20-7</b>                    |  |
| <b>Service Rating</b>     | B, C, F, G = A; Bal. = Inst. | D              |    | D              |    | D           | D           | A, B, G, H = D; C, D, E, F = A |  |
| <b>Number of Contacts</b> | 10                           | 2              | 1  | 2              | 1  | 1           | 4           | 8                              |  |
| <b>Contact Size</b>       | 16                           | 12             | 16 | 12             | 16 | 0           | 12          | 16                             |  |

\* Consult Amphenol, Sidney, NY for availability.  
 \*\* Inactive for new design\  
 • Socket only  
 † one Iron contact and one Constantan contact  
 †† A, C = Iron; B, D = Constantan

**CONTACT LEGEND**

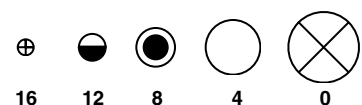

38999  
SJT

26482  
Matrix 2

83723 III  
Pyle

5015  
Crimp Rear Release Matrix

26500 Pyle

Printed  
Circuit Board

EMI Filter  
Transient

Fiber Optics

High Speed  
Contacts

Options  
Others

Front Face of Pin Insert or Rear Face of Socket Insert Illustrated

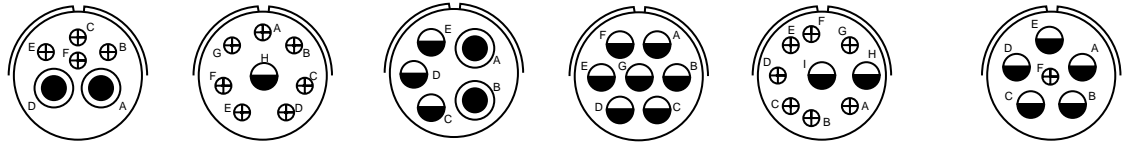

| Insert Arrangement | 20-8* |    | 20-9*           |    | 20-14 |    | 20-15 |    | 20-16 |    | 20-17 |    |
|--------------------|-------|----|-----------------|----|-------|----|-------|----|-------|----|-------|----|
| Service Rating     | Inst. |    | H = D; Bal. = A |    | A     |    | A     |    | A     |    | A     |    |
| Number of Contacts | 2     | 4  | 1               | 7  | 2     | 3  | 7     | 7  | 2     | 7  | 5     | 1  |
| Contact Size       | 8     | 16 | 12              | 16 | 8     | 12 | 12    | 12 | 12    | 16 | 12    | 16 |

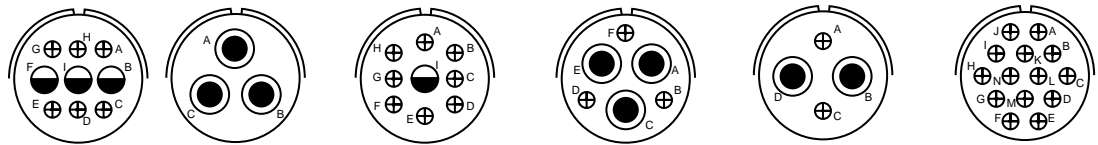

| Insert Arrangement | 20-18 |    | 20-19 |   | 20-21 |    | 20-22 |    | 20-24 |    | 20-27 |  |
|--------------------|-------|----|-------|---|-------|----|-------|----|-------|----|-------|--|
| Service Rating     | A     |    | A     |   | A     |    | A     |    | A     |    | A     |  |
| Number of Contacts | 3     | 6  | 3     | 3 | 1     | 8  | 3     | 3  | 2     | 2  | 14    |  |
| Contact Size       | 12    | 16 | 8     | 8 | 12    | 16 | 8     | 16 | 8     | 16 | 16    |  |

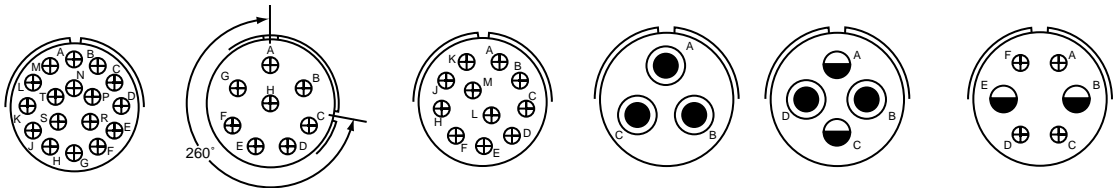

260° Rotation of 20-7

| Insert Arrangement | 20-29 |    | 20-32                    |    | 20-33 |    | 22-2 |   | 22-4** |    | 22-5 |    |
|--------------------|-------|----|--------------------------|----|-------|----|------|---|--------|----|------|----|
| Service Rating     | A     |    | A, B, G, H = D; Bal. = A |    | A     |    | D    |   | A      |    | D    |    |
| Number of Contacts | 17    | 17 | 8                        | 8  | 11    | 11 | 3    | 3 | 2      | 2  | 2    | 4  |
| Contact Size       | 16    | 16 | 16                       | 16 | 16    | 16 | 8    | 8 | 8      | 12 | 12   | 16 |

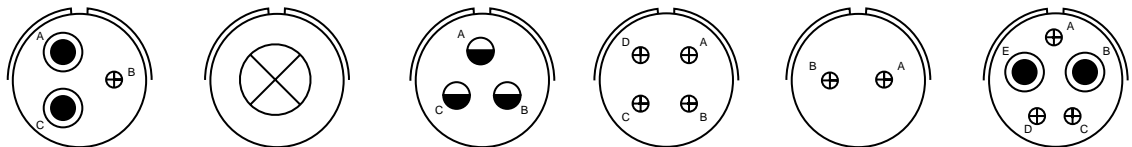

| Insert Arrangement | 22-6** |    | 22-7* |   | 22-9* |    | 22-10* |    | 22-11* |    | 22-12* |    |
|--------------------|--------|----|-------|---|-------|----|--------|----|--------|----|--------|----|
| Service Rating     | D      |    | E     |   | E     |    | E      |    | B      |    | D      |    |
| Number of Contacts | 2      | 1  | 1     | 1 | 3     | 3  | 4      | 4  | 2      | 2  | 2      | 3  |
| Contact Size       | 8      | 16 | 0     | 0 | 12    | 12 | 16     | 16 | 16     | 16 | 8      | 16 |

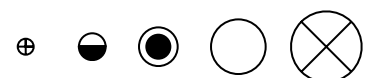

\* Consult Amphenol, Sidney, NY for availability.

**CONTACT LEGEND**

16 12 8 4 0

38999  
SJT I II III

26482  
Matrix 2

83723 III  
Matrix Pyle

5015  
Crimp Rear  
Release Matrix

26500 Pyle

Printed  
Circuit Board

EMI Filter  
Transient

Fiber Optics

High Speed  
Contacts

Options  
Others



# MIL-DTL-5015 Crimp Rear Release Insert Arrangements

Front Face of Pin Insert or Rear Face of Socket Insert Illustrated

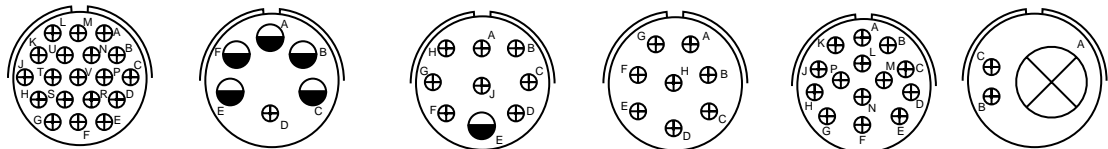

| Insert Arrangement | 22-14 | 22-15*          |    | 22-17*          |    | 22-18*                |  | 22-19 |  | 22-21 |    |
|--------------------|-------|-----------------|----|-----------------|----|-----------------------|--|-------|--|-------|----|
| Service Rating     | A     | D = 3; Bal. = A |    | A = D; Bal. = A |    | C, D, E = A; Bal. = D |  | A     |  | A     |    |
| Number of Contacts | 19    | 5               | 1  | 1               | 8  | 8                     |  | 14    |  | 1     | 2  |
| Contact Size       | 16    | 12              | 16 | 12              | 16 | 16                    |  | 16    |  | 0     | 16 |

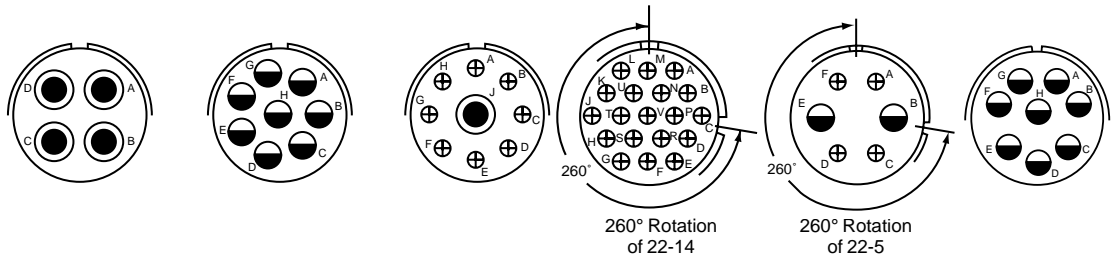

| Insert Arrangement | 22-22 | 22-23           |  | 22-27*          |    | 22-30 |  | 22-32 |    | 22-36*          |  |
|--------------------|-------|-----------------|--|-----------------|----|-------|--|-------|----|-----------------|--|
| Service Rating     | A     | H = D; Bal. = A |  | J = D; Bal. = A |    | A     |  | D     |    | H = D; Bal. = A |  |
| Number of Contacts | 4     | 8               |  | 1               | 8  | 19    |  | 2     | 4  | 8               |  |
| Contact Size       | 8     | 12              |  | 8               | 16 | 16    |  | 12    | 16 | 12              |  |

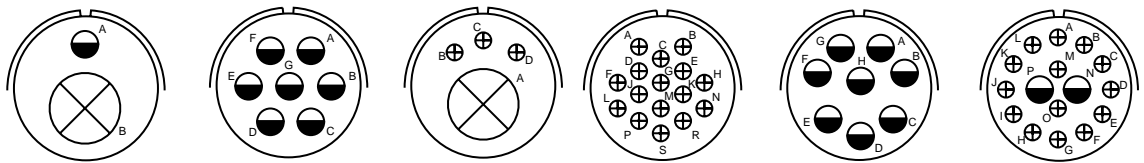

| Insert Arrangement | 24-1** |    | 24-2 |  | 24-4* |    | 24-5** |  | 24-6*                 |  | 24-7 |    |
|--------------------|--------|----|------|--|-------|----|--------|--|-----------------------|--|------|----|
| Service Rating     | D      |    | D    |  | D     |    | A      |  | A, G, H = D; Bal. = A |  | A    |    |
| Number of Contacts | 1      | 1  | 7    |  | 1     | 3  | 16     |  | 8                     |  | 2    | 14 |
| Contact Size       | 0      | 12 | 12   |  | 0     | 16 | 16     |  | 12                    |  | 12   | 16 |

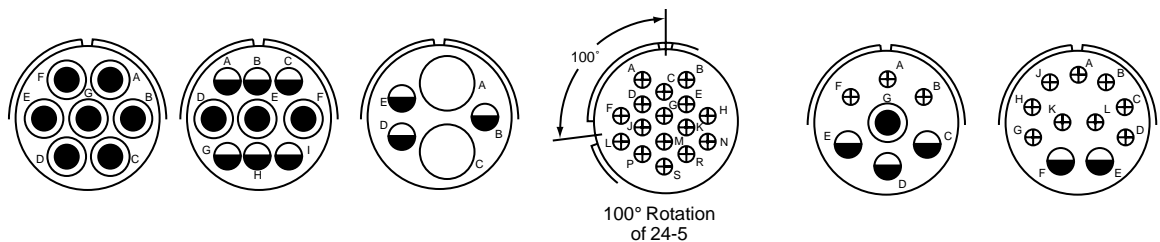

| Insert Arrangement | 24-10 |  | 24-11 |    | 24-12 |    | 24-15 |  | 24-16*                      |    |    | 24-20 |    |
|--------------------|-------|--|-------|----|-------|----|-------|--|-----------------------------|----|----|-------|----|
| Service Rating     | A     |  | A     |    | A     |    | A     |  | A, B, F, G = D; C, D, E = A |    |    | D     |    |
| Number of Contacts | 7     |  | 3     | 6  | 2     | 3  | 16    |  | 1                           | 3  | 3  | 2     | 9  |
| Contact Size       | 8     |  | 8     | 12 | 4     | 12 | 16    |  | 8                           | 12 | 16 | 12    | 16 |

\* Consult Amphenol, Sidney, NY for availability.  
 \*\* Inactive for new design

**CONTACT LEGEND**

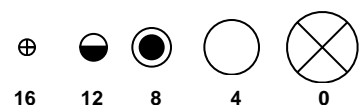

38999  
SJT

26482  
Matrix 2

83723 III  
Pyle

5015  
Crimp Rear Release Matrix

26500 Pyle

Printed  
Circuit Board

EMI Filter  
Transient

Fiber Optics

High Speed  
Contacts

Options  
Others

Front Face of Pin Insert or Rear Face of Socket Insert Illustrated

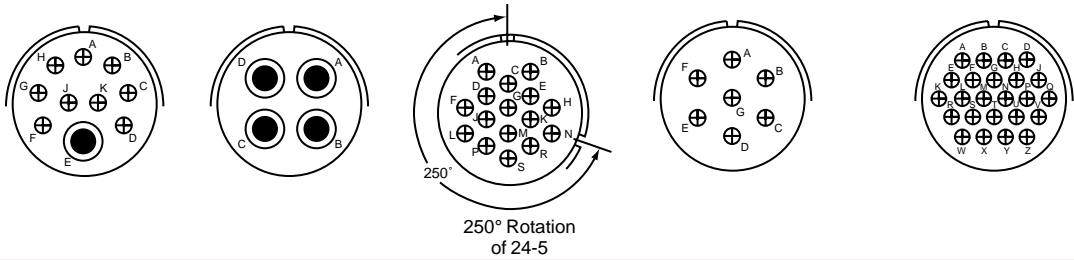

| Insert Arrangement | 24-21* |    | 24-22 |   | 24-24 | 24-27* |  |  | 24-28 |  |
|--------------------|--------|----|-------|---|-------|--------|--|--|-------|--|
| Service Rating     | D      |    | D     |   | A     | E      |  |  | Inst. |  |
| Number of Contacts | 1      | 9  | 4     | 8 | 16    | 7      |  |  | 24    |  |
| Contact Size       | 8      | 16 | 8     | 8 | 16    | 16     |  |  | 16    |  |

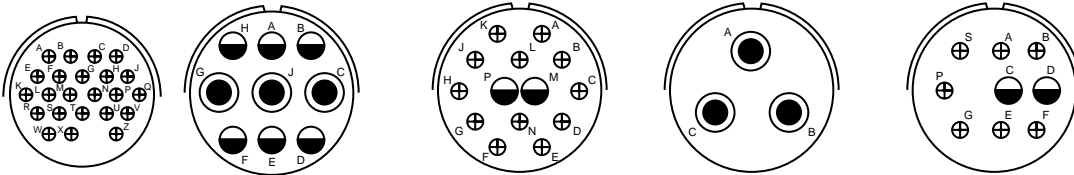

| Insert Arrangement | 24-80* | 28-1                  |    | 28-2 |    | 28-3* |   |  | 28-4*                 |    |
|--------------------|--------|-----------------------|----|------|----|-------|---|--|-----------------------|----|
| Service Rating     | Inst.  | A, J, E = D; Bal. = A |    | D    |    | E     |   |  | G, P, S = E; Bal. = D |    |
| Number of Contacts | 23     | 3                     | 6  | 2    | 12 | 3     | 8 |  | 2                     | 7  |
| Contact Size       | 16     | 8                     | 12 | 12   | 16 | 8     | 8 |  | 12                    | 16 |

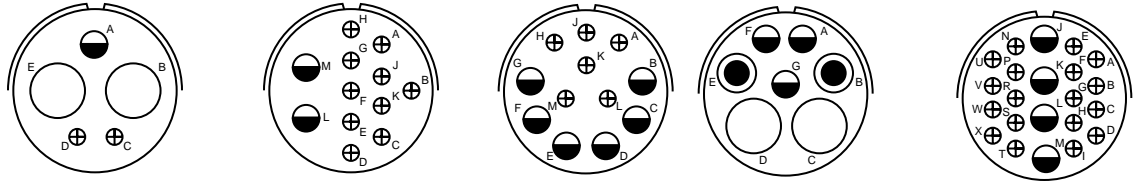

| Insert Arrangement | 28-5* |    |    | 28-8*                     |    | 28-9 |    | 28-10           |   |    | 28-11 |    |
|--------------------|-------|----|----|---------------------------|----|------|----|-----------------|---|----|-------|----|
| Service Rating     | D     |    |    | L, M = E; B = D; Bal. = A |    | D    |    | G = D, Bal. = A |   |    | A     |    |
| Number of Contacts | 2     | 1  | 2  | 2                         | 10 | 6    | 6  | 2               | 2 | 3  | 4     | 18 |
| Contact Size       | 4     | 12 | 16 | 12                        | 16 | 12   | 16 | 4               | 8 | 12 | 12    | 16 |

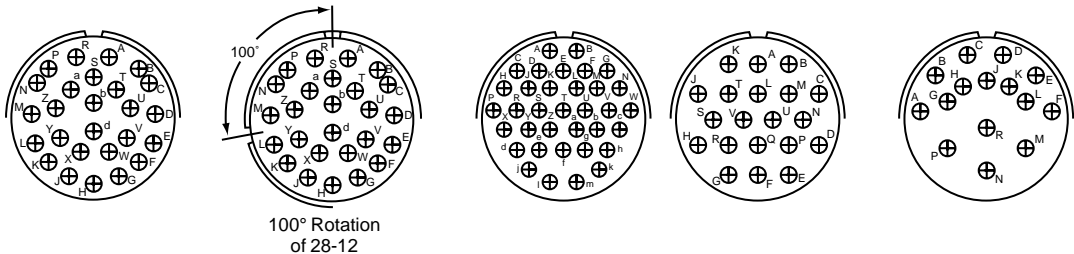

| Insert Arrangement | 28-12 | 28-13 |  | 28-15 | 28-16** | 28-17                        |  |
|--------------------|-------|-------|--|-------|---------|------------------------------|--|
| Service Rating     | A     | A     |  | A     | A       | R = B; M, N, P = D; Bal. = A |  |
| Number of Contacts | 26    | 26    |  | 35    | 20      | 15                           |  |
| Contact Size       | 16    | 16    |  | 16    | 16      | 16                           |  |

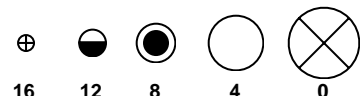

\* Consult Amphenol, Sidney, NY for availability.

CONTACT LEGEND

16 12 8 4 0

38999  
SJT I II III

26482  
Matrix 2

83723 III  
Matrix Pyle

5015  
Crimp Rear  
Release Matrix

26500 Pyle

Printed  
Circuit Board

EMI Filter  
Transient

Fiber Optics

High Speed  
Contacts

Options  
Others

# MIL-DTL-5015 Crimp Rear Release Insert Arrangements

Front Face of Pin Insert or Rear Face of Socket Insert Illustrated

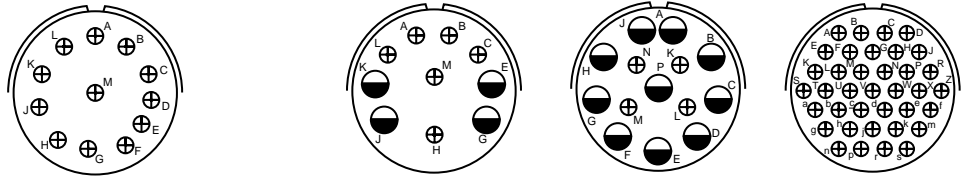

| Insert Arrangement | 28-18*   | 28-19*                       | 28-20    | 28-21 |
|--------------------|--|------------------------------|----------|-------|
| Service Rating     | M = C; G, H, J, K, L = D; A, B = A; Bal. = Inst. | H, M = B; A, B = D; Bal. = A | A        | A     |
| Number of Contacts | 12   | 4      6                     | 10    4  | 37    |
| Contact Size       | 16   | 12      16                   | 12    16 | 16    |

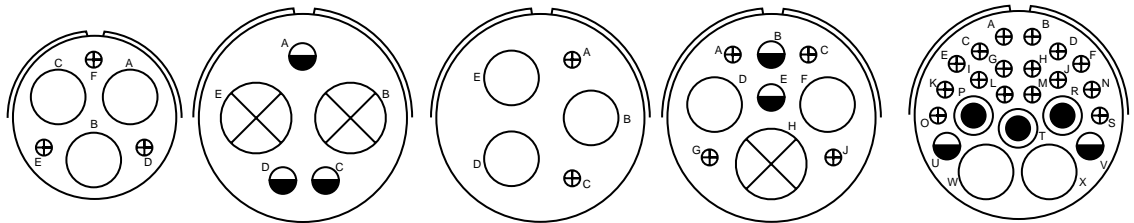

| Insert Arrangement | 28-22   | 32-1                  | 32-2*   | 32-3*              | 32-6               |
|--------------------|---------|-----------------------|---------|--------------------|--------------------|
| Service Rating     | D       | A = E; B, C, D, E = D | E       | D                  | A                  |
| Number of Contacts | 3    3  | 2    3                | 3    2  | 1    2    2    4   | 2    3    2    16  |
| Contact Size       | 4    16 | 0    12               | 4    16 | 0    4    12    16 | 4    8    12    16 |

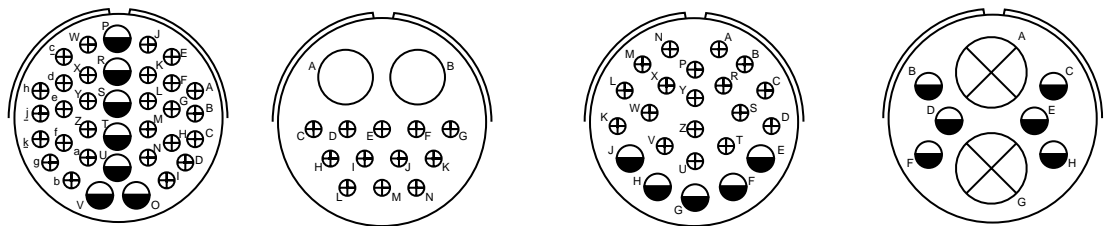

| Insert Arrangement | 32-7                         | 32-9      | 32-13                | 32-15     |
|--------------------|------------------------------|-----------|----------------------|-----------|
| Service Rating     | A, B, h, j = Inst.; Bal. = A | D         | D                    | D         |
| Number of Contacts | 7      28                    | 2      12 | 5    18    2    4    | 2      6  |
| Contact Size       | 12    16                     | 4      16 | 12    16    12    16 | 0      12 |

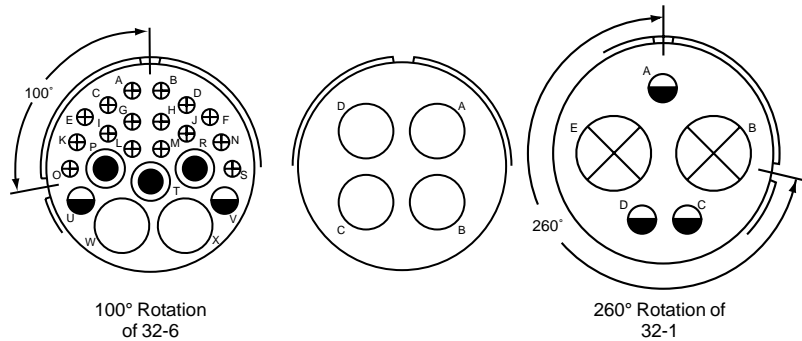

| Insert Arrangement | 32-16              | 32-17 | 32-19           |
|--------------------|--------------------|-------|-----------------|
| Service Rating     | A                  | D     | A = E, Bal. = D |
| Number of Contacts | 2    3    2    16  | 4     | 2    3          |
| Contact Size       | 4    8    12    16 | 4     | 0    12         |

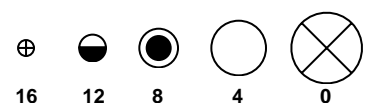

\* Consult Amphenol, Sidney, NY for availability.  
 \*\* Inactive for new design

38999  
SJT

26482  
Matrix 2

83723 III  
Pyle

5015  
Crimp Rear Release Matrix

26500 Pyle

Printed  
Circuit Board

EMI Filter  
Transient

Fiber Optics

High Speed  
Contacts

Options  
Others

### Front Face of Pin Insert or Rear Face of Socket Insert Illustrated

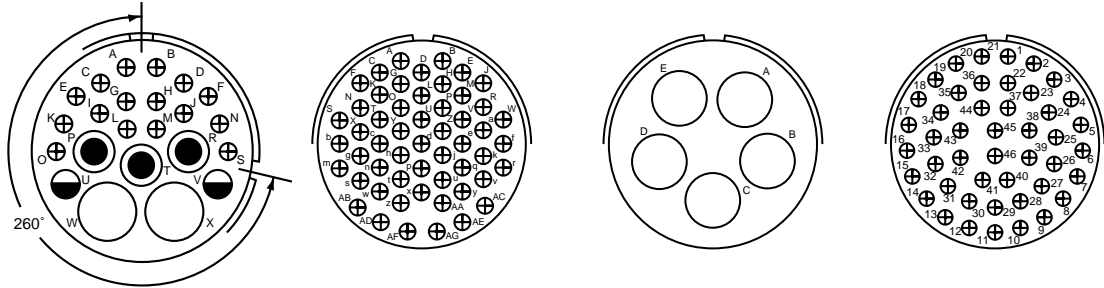

260° Rotation of 32-6

| Insert Arrangement | 32-20 |   |    |    | 32-22* |  |  |  | 32-63 |  |  |  | 32-73 |  |  |  |
|--------------------|-------|---|----|----|--------|--|--|--|-------|--|--|--|-------|--|--|--|
| Service Rating     | A     |   |    |    | A      |  |  |  | D     |  |  |  | A     |  |  |  |
| Number of Contacts | 2     | 3 | 2  | 16 | 54     |  |  |  | 5     |  |  |  | 46    |  |  |  |
| Contact Size       | 4     | 8 | 12 | 16 | 16     |  |  |  | 4     |  |  |  | 16    |  |  |  |

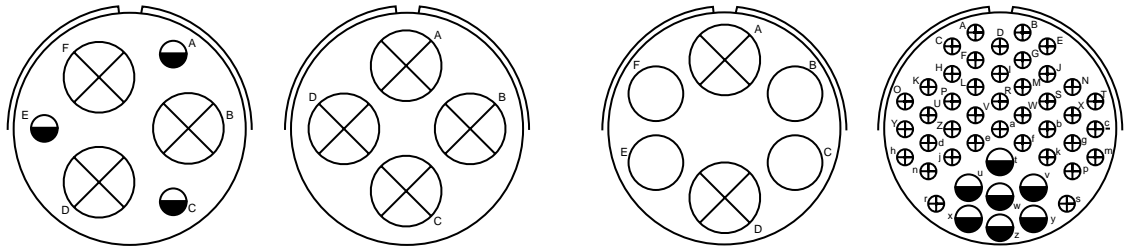

| Insert Arrangement | 36-3 |    | 36-5 |  | 36-6 |   | 36-7 |    |
|--------------------|------|----|------|--|------|---|------|----|
| Service Rating     | D    |    | A    |  | A    |   | A    |    |
| Number of Contacts | 3    | 3  | 4    |  | 2    | 4 | 7    | 40 |
| Contact Size       | 0    | 12 | 0    |  | 0    | 4 | 12   | 16 |

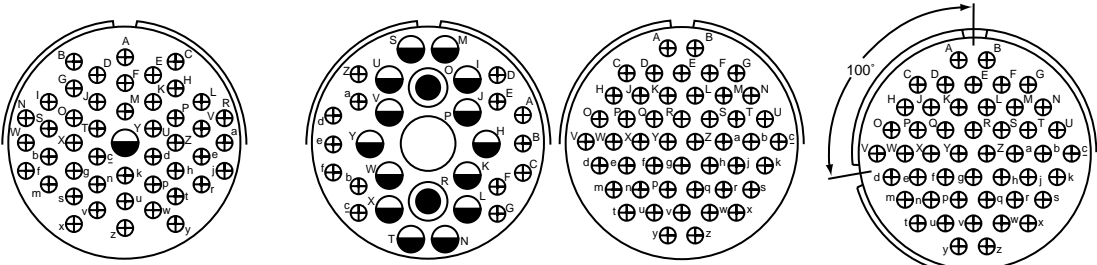

100° Rotation of 36-10

| Insert Arrangement | 36-8 |    | 36-9 |   |    |    | 36-10 |  | 36-11 |  |
|--------------------|------|----|------|---|----|----|-------|--|-------|--|
| Service Rating     | A    |    | A    |   |    |    | A     |  | A     |  |
| Number of Contacts | 1    | 46 | 1    | 2 | 14 | 14 | 48    |  | 48    |  |
| Contact Size       | 12   | 16 | 4    | 8 | 12 | 16 | 16    |  | 16    |  |

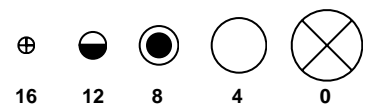

\* Consult Amphenol, Sidney, NY for availability.

#### CONTACT LEGEND

16 12 8 4 0

38999  
SJT I II III

26482  
Matrix 2

83723 III  
Matrix Pyle

5015  
Crimp Rear  
Release Matrix

26500 Pyle

Printed  
Circuit Board

EMI Filter  
Transient

Fiber Optics

High Speed  
Contacts

Options  
Others

# MIL-DTL-5015 Crimp Rear Release Insert Arrangements

Front Face of Pin Insert or Rear Face of Socket Insert Illustrated

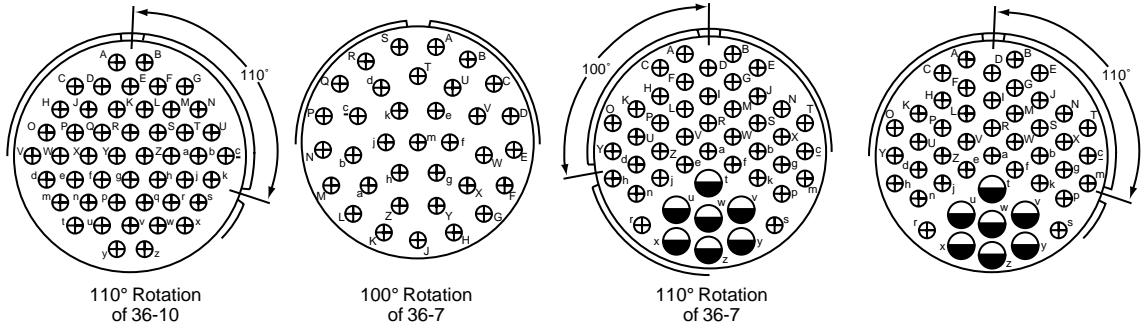

| Insert Arrangement | 36-12 | 36-15           | 36-16 |    | 36-17 |    |
|--------------------|-------|-----------------|-------|----|-------|----|
| Service Rating     | A     | M = D, Bal. = A | A     |    | A     |    |
| Number of Contacts | 48    | 35              | 7     | 40 | 7     | 40 |
| Contact Size       | 16    | 16              | 12    | 16 | 12    | 16 |

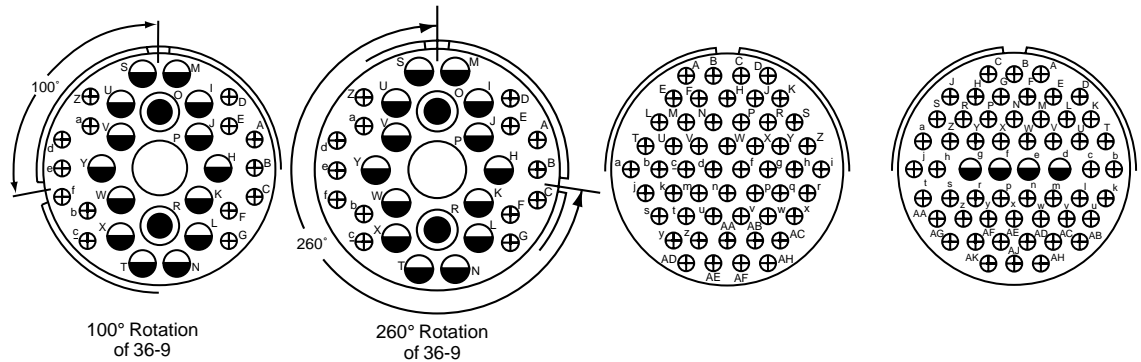

| Insert Arrangement | 36-18 |   |    |    | 36-21 |   |    |    | 36-52 | 36-66* |    |
|--------------------|-------|---|----|----|-------|---|----|----|-------|--------|----|
| Service Rating     | A     |   |    |    | A     |   |    |    | A     | A      |    |
| Number of Contacts | 1     | 2 | 14 | 14 | 1     | 2 | 14 | 14 | 52    | 4      | 52 |
| Contact Size       | 4     | 8 | 12 | 16 | 4     | 8 | 12 | 16 | 16    | 12     | 16 |

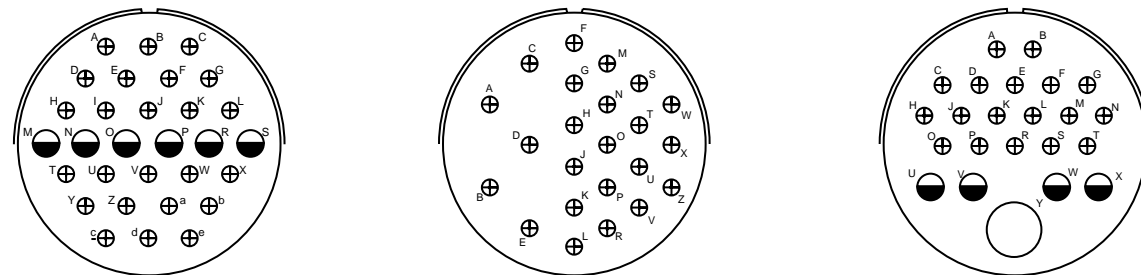

| Insert Arrangement | 40-1 |    | 40-2* | 40-3* |    |    |
|--------------------|------|----|-------|-------|----|----|
| Service Rating     | D    |    | D     | D     |    |    |
| Number of Contacts | 6    | 24 | 23    | 1     | 4  | 18 |
| Contact Size       | 12   | 16 | 16    | 4     | 12 | 16 |

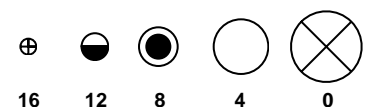

\* Consult Amphenol, Sidney, NY for availability.

**CONTACT LEGEND**

16 12 8 4 0

38999  
II  
I  
SJT

26482  
Matrix 2

83723 III  
Matrix  
Pyle

5015  
Crimp Rear  
Release Matrix

26500 Pyle

Printed  
Circuit Board

EMI Filter  
Transient

Fiber Optics

High Speed  
Contacts

Options  
Others

Front Face of Pin Insert or Rear Face of Socket Insert Illustrated

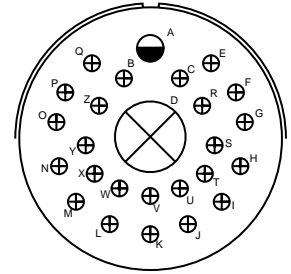
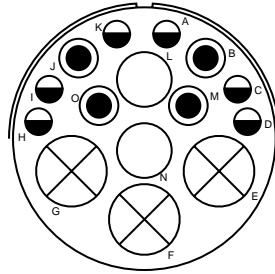
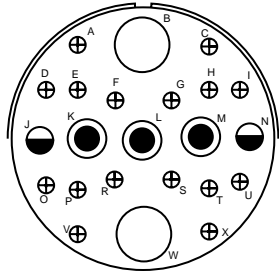

| Insert Arrangement | 40-4* |   |    |    | 40-5* |   |   |    | 40-6* |    |    |
|--------------------|-------|---|----|----|-------|---|---|----|-------|----|----|
| Service Rating     | D     |   |    |    | A     |   |   |    | D     |    |    |
| Number of Contacts | 2     | 3 | 2  | 16 | 3     | 2 | 4 | 6  | 1     | 1  | 24 |
| Contact Size       | 4     | 8 | 12 | 16 | 0     | 4 | 8 | 12 | 0     | 12 | 16 |

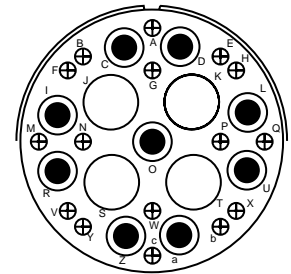
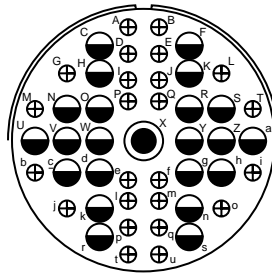
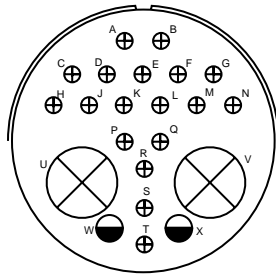

| Insert Arrangement | 40-7*                          |    |    | 40-9 |    |    | 40-10* |   |    |
|--------------------|--------------------------------|----|----|------|----|----|--------|---|----|
| Service Rating     | P, Q, U, V, W, X = A; Bal. = D |    |    | A    |    |    | A      |   |    |
| Number of Contacts | 2                              | 2  | 18 | 1    | 22 | 24 | 4      | 9 | 16 |
| Contact Size       | 0                              | 12 | 16 | 8    | 12 | 16 | 4      | 8 | 16 |

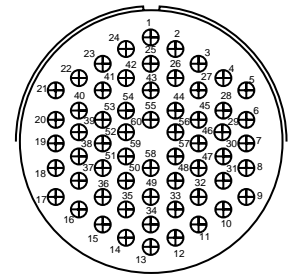
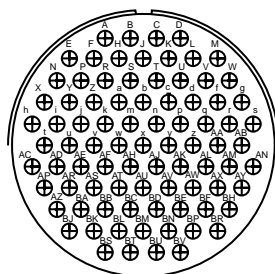
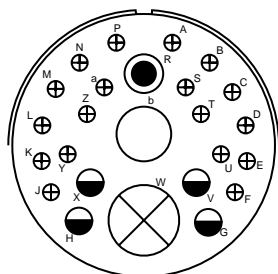

| Insert Arrangement | 40-11* |   |   |    |    | 40-56 | 40-62* |
|--------------------|--------|---|---|----|----|-------|--------|
| Service Rating     | D      |   |   |    |    | A     | A      |
| Number of Contacts | 1      | 1 | 1 | 4  | 18 | 85    | 60     |
| Contact Size       | 0      | 4 | 8 | 12 | 16 | 16    | 16     |



\* Consult Amphenol, Sidney, NY for availability.

CONTACT LEGEND

16 12 8 4 0

38999  
SJT I II III

26482  
Matrix 2

83723 III  
Matrix Pyle

5015  
Crimp Rear  
Release Matrix

26500 Pyle

Printed  
Circuit Board

EMI Filter  
Transient

Fiber Optics

High Speed  
Contacts

Options  
Others



III  
II  
I  
SJT

38999

Matrix 2

26482

Matrix  
Pyle

83723 III

5015  
Crimp Rear  
Release Matrix

26500 Pyle

Printed  
Circuit Board

EMI Filter  
Transient

Fiber Optics

High Speed  
Contacts

Options  
Others

### CLASS DESCRIPTIONS

| Military MIL-DTL-5015 |  |
|-----------------------|--|
| Class L*              | Aluminum shell, electroless nickel finish, fluid resistant insert  |
| Class W               | Aluminum shell, cadmium olive drab finish, fluid resistant insert  |
| Class LS              | Stainless steel shell, passivated, fluid resistant insert  |
| Class KT**            | Firewall, steel shell, cadmium olive drab finish, non-flammable hard dielectric and fluid resistant insert |
| Class KS              | Firewall, stainless steel shell, passivated, non-flammable hard dielectric and fluid resistant insert      |

| Amphenol/Matrix |  |
|-----------------|--|
| Class A         | Aluminum shell, black anodize finish, fluid resistant insert   |
| Class F         | Aluminum shell, electroless nickel finish, fluid resistant insert  |
| Class W         | Aluminum shell, cadmium/olive drab finish, fluid resistant insert  |
| Class FS        | Stainless steel shell, passivated, fluid resistant insert  |
| Class KT        | Firewall, steel shell, cadmium olive drab finish, non-flammable hard dielectric and fluid resistant insert |
| Class KS        | Firewall, stainless steel shell, passivated, non-flammable hard dielectric and fluid resistant insert      |

\* Class L inactivates older Class U (aluminum, electroless nickel)

\*\* Class KT (ferrous alloy, cadmium/olive drab) inactivates older Class K (ferrous alloy, electroless nickel)

### PERFORMANCE SPECIFICATIONS

#### VOLTAGE RATING

| Altitude    | Inst. | A    | D    | E    | B    | C    |
|-------------|-------|------|------|------|------|------|
| Sea Level   | 1000  | 2000 | 2800 | 3500 | 4500 | 7000 |
| 50,000 ft.  | 400   | 600  | 675  | 750  | 825  | 975  |
| 70,000 ft.  | 260   | 360  | 400  | 440  | 480  | 560  |
| 110,000 ft. | 200   | 200  | 200  | 200  | 200  | 200  |

### SHOCK

Wired, mated connectors are subjected to one shock in each of three mutually perpendicular axes with pulse of an approximate half sine wave of 50g magnitude for a duration of 11 milliseconds. All contacts wired in series circuit with 100 ±10 Milliampères of current flow.

### OPERATING TEMPERATURE RANGE

Classes L, LS and KS have temperature range of -55°C (-75°F) to 200°C (392°F)

Classes W and KT have temperature range of -55°C (-75°F) to 175°C (347°F)

### ENVIRONMENTAL SEAL

Wired, mated connectors with the specified accessory attached will meet the altitude immersion test specified in MIL-DTL-5015.

### DURABILITY

Minimum of 100 mating cycles.

38999 SJT I II III  
26482 Matrix 2  
83723 III Pyle Matrix  
5015 Crimp Rear Release Matrix  
26500 Pyle  
Printed Circuit Board  
EMI Filter Transient  
Fiber Optics  
High Speed Contacts  
Options Others

To avoid cross-plugging problems in applications requiring the use of more than one connector of the same size and arrangement, alternate rotations are available as indicated in the accompanying charts.

As shown in the diagram below, the front face of the pin insert is rotated within the shell in a clockwise direction from the normal shell key. The socket insert would be rotated counter-clockwise the same number of degrees in respect to the normal shell key.

The charts give the W, X, Y, Z positions for the alternate rotations available for the insert arrangements of the rear release MIL-DTL-5015 series of connectors. If an insert arrangement number is not given, then there is no available alternate rotation for that pattern.

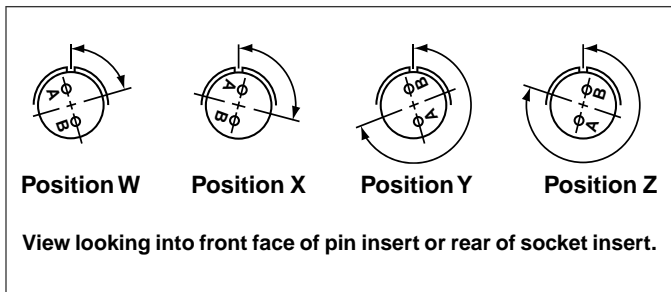

The following insert arrangements have the same alternate insert rotations for W, X, Y and Z, which are:

| Degrees |     |     |     |
|---------|-----|-----|-----|
| W       | X   | Y   | Z   |
| 80      | 110 | 250 | 280 |

|       |       |       |       |       |       |
|-------|-------|-------|-------|-------|-------|
| 16-7  | 20-22 | 24-4  | 28-4  | 28-21 | 40-3  |
| 18-5  | 22-6  | 24-5  | 28-8  | 32-1  | 40-4  |
| 18-9  | 22-12 | 24-6  | 28-9  | 32-3  | 40-5  |
| 18-13 | 22-14 | 24-7  | 28-10 | 32-6  | 40-6  |
| 18-14 | 22-15 | 24-12 | 28-11 | 32-9  | 40-7  |
| 20-7  | 22-17 | 24-16 | 28-15 | 32-13 | 40-11 |
| 20-8  | 22-18 | 24-20 | 28-16 | 32-22 |       |
| 20-9  | 22-19 | 24-21 | 28-17 | 36-7  |       |
| 20-14 | 22-21 | 24-28 | 28-19 | 36-8  |       |
| 20-16 | 24-1  | 28-1  | 28-20 | 40-2  |       |

| Insert Arrangement | Degrees |     |     |     |
|--------------------|---------|-----|-----|-----|
|                    | W       | X   | Y   | Z   |
| 12S-3              | 70      | 145 | 215 | 290 |
| 14S-2              | -       | 120 | 240 | -   |
| 14S-5              | -       | 110 | -   | -   |
| 14S-7              | 90      | 180 | 270 | -   |
| 14S-9              | 70      | 145 | 215 | 290 |
| 16S-1              | 80      | -   | -   | 280 |
| 16S-4              | 35      | 110 | 250 | 325 |
| 16S-8              | -       | 170 | 265 | -   |
| 16-9               | 35      | 110 | 250 | 325 |
| 16-10              | 90      | 180 | 270 | -   |
| 16-11              | 35      | 110 | 250 | 325 |
| 16-13              | 35      | 110 | 250 | 325 |
| 18-1               | 70      | 145 | 215 | 290 |
| 18-4               | 35      | 110 | 250 | 325 |
| 18-8               | 70      | -   | -   | 290 |
| 18-10              | -       | 120 | 240 | -   |
| 18-11              | -       | 170 | 265 | -   |
| 18-12              | 80      | -   | -   | 280 |
| 18-15              | -       | 120 | 240 | -   |
| 18-19              | -       | 120 | 240 | -   |
| 18-22              | 70      | 145 | 215 | 290 |
| 20-4               | 45      | 110 | 250 | -   |
| 20-15              | 80      | -   | -   | 280 |

| Insert Arrangement | Degrees |     |     |     |
|--------------------|---------|-----|-----|-----|
|                    | W       | X   | Y   | Z   |
| 20-17              | 90      | 180 | 270 | -   |
| 20-18              | 35      | 110 | 250 | 325 |
| 20-19              | 90      | 180 | 270 | -   |
| 20-21              | 35      | 110 | 250 | 325 |
| 20-24              | 35      | 110 | 250 | 325 |
| 20-27              | 35      | 110 | 250 | 325 |
| 20-29              | 80      | -   | -   | 280 |
| 22-2               | 70      | 145 | 215 | 290 |
| 22-4               | 35      | 110 | 250 | 325 |
| 22-5               | 35      | 110 | 250 | 325 |
| 22-9               | 70      | 145 | 215 | 290 |
| 22-10              | 35      | 110 | 250 | 325 |
| 22-11              | 35      | 110 | 250 | 325 |
| 22-22              | -       | 110 | 250 | -   |
| 22-23              | 35      | -   | 250 | -   |
| 22-27              | 80      | -   | 250 | 280 |
| 22-36              | 90      | -   | 270 | -   |
| 24-2               | 80      | -   | -   | 280 |
| 24-10              | 80      | -   | -   | 280 |
| 24-11              | 35      | 110 | 250 | 325 |
| 24-22              | 45      | 110 | 250 | -   |
| 24-27              | 80      | -   | -   | 280 |
| 24-80              | 35      | 145 | 240 | 300 |

| Insert Arrangement | Degrees |     |     |     |
|--------------------|---------|-----|-----|-----|
|                    | W       | X   | Y   | Z   |
| 28-2               | 35      | 110 | 250 | 325 |
| 28-3               | 70      | 145 | 215 | 290 |
| 28-5               | 35      | 110 | 250 | 325 |
| 28-12              | 90      | 180 | 270 | -   |
| 28-18              | 70      | 145 | 215 | 290 |
| 28-22              | 70      | 145 | 215 | 290 |
| 32-2               | 70      | 145 | 215 | 290 |
| 32-7               | 80      | 125 | 235 | 280 |
| 32-15              | 35      | 110 | 250 | 280 |
| 32-17              | 45      | 110 | 250 | -   |
| 32-73              | 36      | -   | -   | -   |
| 36-3               | 70      | 145 | 215 | 290 |
| 36-5               | -       | 120 | 240 | -   |
| 36-6               | 35      | 110 | 250 | 325 |
| 36-9               | 80      | 125 | 235 | 280 |
| 36-10              | 80      | 125 | 235 | 280 |
| 36-15              | 60      | 125 | 245 | 305 |
| 36-52              | 72      | 144 | 216 | 288 |
| 36-66              | 110     | 250 | 260 | 280 |
| 40-1               | 65      | 130 | 235 | 300 |
| 40-9               | 65      | 125 | 255 | 310 |
| 40-10              | 65      | 125 | 255 | 310 |
| 40-56              | 72      | 144 | 216 | 288 |
| 40-62              | 30      | 130 | 220 | 290 |

|   | 1.             | 2.          | 3.            | 4.                            | 5.            | 6.                  | 7.                  |
|---|----------------|-------------|---------------|-------------------------------|---------------|---------------------|---------------------|
| MIL-DTL-5015 with rear release crimp contacts | Connector Type | Shell Style | Service class | Shell Size–Insert Arrangement | Contact Types | Alternate Positions | Modification Number |
| <b>MILITARY</b>                               | <b>MS</b>      | <b>3456</b> | <b>L</b>      | <b>16S-8</b>                  | <b>P</b>      | <b>W</b>            | <b>NA</b>           |
| <b>COMMERCIAL</b>                             | <b>944</b>     | <b>6</b>    | <b>F</b>      | <b>16S-8</b>                  | <b>P</b>      | <b>W</b>            | <b>(XXX)</b>        |

### Step 1. Military Connector Type

|           |                              |
|-----------|------------------------------|
| <b>MS</b> | Designates Military Standard |
|-----------|------------------------------|

### Step 2. Select a Shell Style

#### THREADED COUPLING CONNECTORS

|             |  |
|-------------|--|
| <b>3450</b> | Wall mounting receptacle                     |
| <b>3451</b> | Cable connecting receptacle                  |
| <b>3452</b> | Box mounting receptacle                      |
| <b>3454</b> | Jam nut receptacle                           |
| <b>3456</b> | Straight plug                                |
| <b>3459</b> | Straight plug with self-locking coupling nut |

### Step 3. Select a Service Class

|   |  |
|---|--|
| <b>L</b>  | Aluminum shell, electroless nickel finish, fluid resistant insert  |
| <b>W</b>  | Aluminum shell, cadmium olive drab finish, fluid resistant insert  |
| <b>LS</b>   | Stainless steel shell, passivated, fluid resistant insert  |
| Firewall Styles only available for 3450, 3456, 3459 per mil spec: |  |
| <b>KT</b>   | Firewall, steel shell, cadmium/olive drab finish, non-flammable hard dielectric and fluid resistant insert |
| <b>KS</b>   | Firewall, stainless steel shell, passivated, non-flammable hard dielectric and fluid resistant insert      |

Note: Class L inactivates older Class U.  
Class K is inactive and has been replaced by Class KT for all applications.

### Step 4. Select a Shell Size & Insert Arrangement see pages 172 & 173

Shell Size & Insert Arrangements are on pages 172 & 173. First number represents Shell Size, second number is the Insert Arrangement.

### Step 5. Select a Contact Type

|          |              |
|----------|--------------|
|          | Designates   |
| <b>P</b> | Pin          |
| <b>S</b> | Socket       |
| <b>A</b> | Less pins    |
| <b>B</b> | Less sockets |

### Step 6. Alternate Positions

“W”, “X”, “Y”, “Z” designate that insert is rotated in its shell from normal position. No letter required for normal (no rotation) position. See page 184 for description of alternate positions.

### Step 1. Select a Commercial Connector Type

|            |   |
|------------|---|
| <b>944</b> | Designates Amphenol/Matrix Commercial Series            |
| <b>981</b> | Designates self locking/Quick disconnect (+)(-) lanyard |

### Step 2. Select a Shell Style

#### THREADED COUPLING CONNECTORS

|   |  |
|---|--|
| <b>0</b>                                    | Wall mounting receptacle                     |
| <b>1</b>                                    | Cable connecting receptacle                  |
| <b>2</b>                                    | Box mounting receptacle                      |
| <b>4</b>                                    | Jam nut receptacle                           |
| <b>6</b>                                    | Straight plug                                |
| Self Locking/Quick disconnect (981) styles: |  |
| <b>6</b>                                    | Straight plug with self-locking coupling nut |
| <b>7</b>                                    | Quick disconnect plug with lanyard           |
| <b>8</b>                                    | Quick disconnect plug without lanyard        |

### Step 3. Select a Service Class

|           |  |
|-----------|--|
| <b>A</b>  | Aluminum shell, black anodized finish, fluid resistant insert  |
| <b>F</b>  | Aluminum shell, electroless nickel finish, fluid resistant insert  |
| <b>W</b>  | Aluminum shell, cadmium olive drab finish, fluid resistant insert  |
| <b>FS</b> | Stainless steel shell, passivated, fluid resistant insert  |
| <b>KT</b> | Firewall, steel shell, cadmium/olive drab finish, non-flammable hard dielectric and fluid resistant insert |
| <b>KS</b> | Firewall, stainless steel shell, passivated, non-flammable hard dielectric and fluid resistant insert      |

### Step 4. Select a Shell Size & Insert Arrangement see pages 172 & 173

Shell Size & Insert Arrangements are on pages 172 & 173. First number represents Shell Size, second number is the Insert Arrangement.

### Step 5. Select a Contact Type

|          |            |
|----------|------------|
|          | Designates |
| <b>P</b> | Pin        |
| <b>S</b> | Socket     |

### Step 6. Alternate Positions

“W”, “X”, “Y”, “Z” designate that insert is rotated in its shell from normal position. No letter required for normal (no rotation) position. See page 184 for description of alternate positions.

### Step 7. Modification Number

Consult Amphenol, Sidney, NY for information. For strain reliefs use the following modification codes:

- (189) E-nut M85049/31 configuration
- (190) Straight strain relief M85049/52 configuration
- (191) 90° strain relief M85049/51 configuration

III  
II  
I  
SJT  
38999

Matrix 2  
26482

Matrix  
Pyle  
83723 III

5015  
Crimp Rear  
Release Matrix

26500 Pyle

Printed  
Circuit Board

EMI Filter  
Transient

Fiber Optics

High Speed  
Contacts

Options  
Others

**PART # Receptacle Shell, Flange Wall Mount, Threaded Coupling.**  
To complete, see how to order page 185

| MIL-DTL-5015      | Connector Type | Shell Style | Service Class | Shell Size-Insert Arrangement | Contact Type | Alternate Rotation | Modification Number |
|-------------------|----------------|-------------|---------------|-------------------------------|--------------|--------------------|---------------------|
| <b>Military</b>   | <b>MS</b>      | <b>3450</b> | <i>L</i>      | <i>16S-8</i>                  | <i>P</i>     | <i>W</i>           | <b>NA</b>           |
| <b>Commercial</b> | <b>944</b>     | <b>0</b>    | <i>F</i>      | <i>16S-8</i>                  | <i>P</i>     | <i>W</i>           | <i>xxx</i>          |

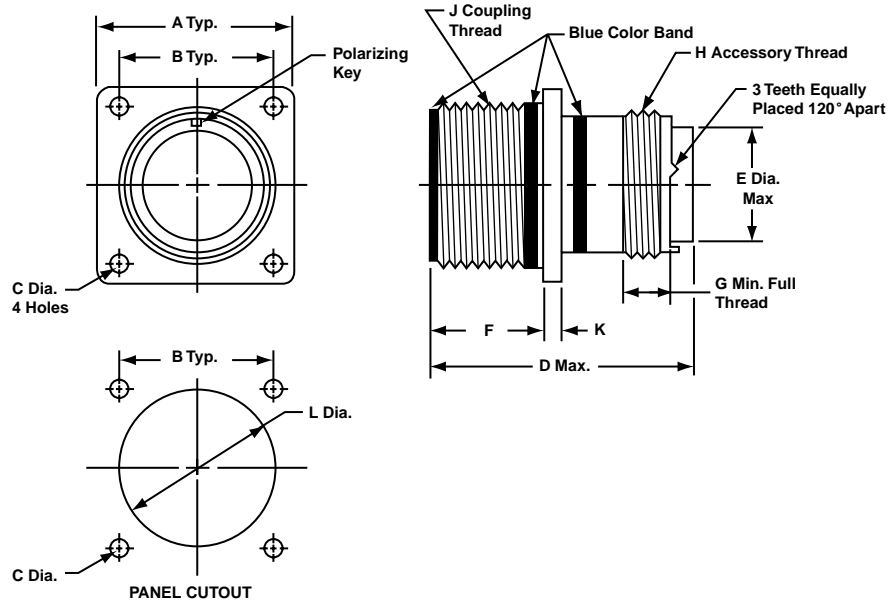

| Shell Size* | A ±.031 | B     | C Dia. +.010 - .005 |         | D Max.                |                       | E Dia. Max. | F         | G Min. | H Thread Class 2A | J Thread Class 2A | K    | L Dia. ±.010 |
|-------------|---------|-------|---------------------|---------|-----------------------|-----------------------|-------------|-----------|--------|-------------------|-------------------|------|--------------|
|             |         |       | Class A, F, R, W    | Class K | Size 16 & 12 Contacts | Size 8, 4, 0 Contacts |             |           |        |                   |                   |      |              |
| 8S          | .875    | .594  | .120                | .150    | 2.031                 | —                     | .305        | .593/.562 | .290   | .5000-20 UNEF     | .5000-28 UNEF     | .083 | .562         |
| 10S         | 1.000   | .719  | .120                | .150    | 2.031                 | —                     | .405        | .593/.562 | .290   | .6250-24 UNEF     | .6250-24 UNEF     | .083 | .688         |
| 10SL        | 1.000   | .719  | .120                | .150    | 2.031                 | —                     | .405        | .593/.562 | .290   | .6250-24 UNEF     | .6250-24 UNEF     | .083 | .688         |
| 12          | 1.094   | .812  | .120                | .150    | 2.125                 | —                     | .549        | .781/.750 | .290   | .7500-20 UNEF     | .7500-20 UNEF     | .083 | .812         |
| 12S         | 1.094   | .812  | .120                | .150    | 2.031                 | —                     | .549        | .593/.562 | .290   | .7500-20 UNEF     | .7500-20 UNEF     | .083 | .812         |
| 14          | 1.188   | .906  | .120                | .150    | 2.125                 | —                     | .665        | .781/.750 | .290   | .8750-20 UNEF     | .8750-20 UNEF     | .083 | .938         |
| 14S         | 1.188   | .906  | .120                | .150    | 2.031                 | —                     | .665        | .593/.562 | .290   | .8750-20 UNEF     | .8750-20 UNEF     | .083 | .938         |
| 16          | 1.281   | .969  | .120                | .150    | 2.125                 | 2.500                 | .790        | .781/.750 | .290   | 1.0000-20 UNEF    | 1.0000-20 UNEF    | .083 | 1.062        |
| 16S         | 1.281   | .969  | .120                | .150    | 2.031                 | —                     | .790        | .593/.562 | .290   | 1.0000-20 UNEF    | 1.0000-20 UNEF    | .083 | 1.062        |
| 18          | 1.375   | 1.062 | .120                | .177    | 2.125                 | 2.500                 | .869        | .781/.750 | .290   | 1.0625-18 UNEF    | 1.1250-18 UNEF    | .125 | 1.188        |
| 20          | 1.500   | 1.156 | .120                | .177    | 2.125                 | 2.500                 | .994        | .781/.750 | .290   | 1.1875-18 UNEF    | 1.2500-18 UNEF    | .125 | 1.312        |
| 22          | 1.625   | 1.250 | .120                | .177    | 2.125                 | 2.500                 | 1.119       | .781/.750 | .290   | 1.3125-18 UNEF    | 1.3750-18 UNEF    | .125 | 1.438        |
| 24          | 1.750   | 1.375 | .147                | .177    | 2.125                 | 2.500                 | 1.244       | .843/.812 | .290   | 1.4375-18 UNEF    | 1.5000-18 UNEF    | .125 | 1.562        |
| 28          | 2.000   | 1.562 | .147                | .177    | 2.125                 | 2.500                 | 1.465       | .843/.812 | .467   | 1.7500-18 UNS     | 1.7500-18 UNS     | .125 | 1.812        |
| 32          | 2.250   | 1.750 | .173                | .209    | 2.125                 | 2.500                 | 1.715       | .906/.875 | .467   | 2.0000-18 UNS     | 2.0000-18 UNS     | .125 | 2.062        |
| 36          | 2.500   | 1.938 | .173                | .209    | 2.125                 | 2.500                 | 1.930       | .906/.875 | .467   | 2.2500-16 UN      | 2.2500-16 UN      | .125 | 2.312        |
| 40          | 2.750   | 2.188 | .173                | .209    | 2.125                 | 2.500                 | 2.145       | .906/.875 | .467   | 2.5000-16 UN      | 2.5000-16 UN      | .125 | 2.562        |

\* Consult Amphenol, Sidney, NY for availability of shell sizes 44 and 48.

38999 I II III  
SJT  
26482 Matrix 2  
83723 III Matrix Pyle  
5015 Crimp Rear Release Matrix  
26500 Pyle  
Printed Circuit Board  
EMI Filter Transient  
Fiber Optics  
High Speed Contacts  
Options Others

# MS3451, MIL-DTL-5015 Crimp Rear Release Cable Connecting Receptacle



## PART # Receptacle Shell, Cable Connecting, Threaded Coupling. To complete, see how to order page 185

| MIL-DTL-5015      | Connector Type | Connector Style | Service Class | Shell Size—<br>Insert Arrangement | Contact Type | Insert Rotation | Modification Number |
|-------------------|----------------|-----------------|---------------|-----------------------------------|--------------|-----------------|---------------------|
| <b>Military</b>   | <b>MS</b>      | <b>3451</b>     | <i>L</i>      | <i>16S-8</i>                      | <i>P</i>     | <i>W</i>        | <b>NA</b>           |
| <b>Commercial</b> | <b>944</b>     | <b>1</b>        | <i>F</i>      | <i>16S-8</i>                      | <i>P</i>     | <i>W</i>        | <i>xxx</i>          |

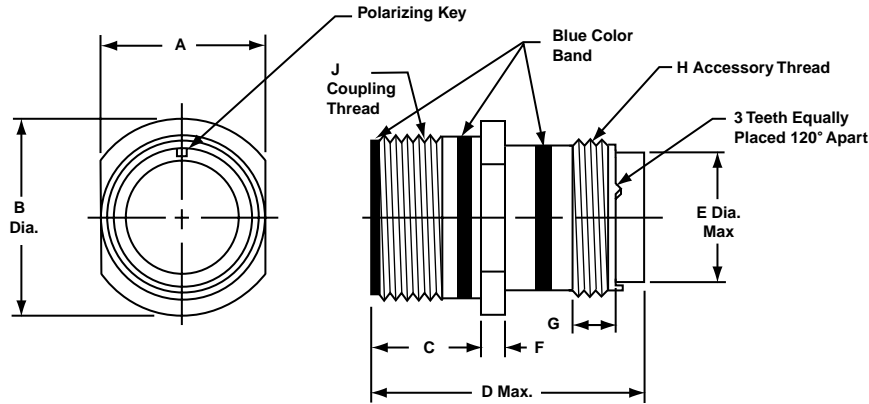

| Shell Size | A           | B Dia. ±.031 | C         | D Max.                |                       | E Dia. Max. | F ±.015 | G Min. | H Thread Class 2A | J Thread Class 2A |
|------------|-------------|--------------|-----------|-----------------------|-----------------------|-------------|---------|--------|-------------------|-------------------|
|            |             |              |           | Size 16 & 12 Contacts | Size 8, 4, 0 Contacts |             |         |        |                   |                   |
| 8S         | .504/.496   | .729         | .577/.562 | 2.031                 | —                     | .305        | .083    | .290   | .5000-20 UNEF     | .5000-28 UNEF     |
| 10S        | .629/.621   | .854         | .577/.562 | 2.031                 | —                     | .405        | .083    | .290   | .6250-24 UNEF     | .6250-24 UNEF     |
| 10SL       | .629/.621   | .854         | .577/.562 | 2.031                 | —                     | .405        | .083    | .290   | .6250-24 UNEF     | .6250-24 UNEF     |
| 12         | .754/.746   | .974         | .765/.750 | 2.125                 | —                     | .549        | .083    | .290   | .7500-20 UNEF     | .7500-20 UNEF     |
| 12S        | .754/.746   | .974         | .577/.562 | 2.031                 | —                     | .549        | .083    | .290   | .7500-20 UNEF     | .7500-20 UNEF     |
| 14         | .879/.871   | 1.099        | .765/.750 | 2.125                 | —                     | .665        | .083    | .290   | .8750-20 UNEF     | .8750-20 UNEF     |
| 14S        | .879/.871   | 1.099        | .577/.562 | 2.031                 | —                     | .665        | .083    | .290   | .8750-20 UNEF     | .8750-20 UNEF     |
| 16         | 1.005/.996  | 1.224        | .765/.750 | 2.125                 | 2.500                 | .790        | .083    | .290   | 1.0000-20 UNEF    | 1.0000-20 UNEF    |
| 16S        | 1.005/.996  | 1.224        | .577/.562 | 2.031                 | —                     | .790        | .083    | .290   | 1.0000-20 UNEF    | 1.0000-20 UNEF    |
| 18         | 1.131/1.121 | 1.349        | .765/.750 | 2.125                 | 2.500                 | .869        | .125    | .290   | 1.0625-18 UNEF    | 1.1250-18 UNEF    |
| 20         | 1.256/1.246 | 1.474        | .765/.750 | 2.125                 | 2.500                 | .994        | .125    | .290   | 1.1875-18 UNEF    | 1.2500-18 UNEF    |
| 22         | 1.381/1.371 | 1.599        | .765/.750 | 2.125                 | 2.500                 | 1.119       | .125    | .290   | 1.3125-18 UNEF    | 1.3750-18 UNEF    |
| 24         | 1.506/1.496 | 1.715        | .827/.812 | 2.125                 | 2.500                 | 1.244       | .125    | .290   | 1.4375-18 UNEF    | 1.5000-18 UNEF    |
| 28         | 1.756/1.746 | 1.974        | .827/.812 | 2.125                 | 2.500                 | 1.465       | .125    | .467   | 1.7500-18 UNS     | 1.7500-18 UNS     |
| 32         | 2.007/1.996 | 2.224        | .890/.870 | 2.125                 | 2.500                 | 1.715       | .125    | .467   | 2.0000-18 UNS     | 2.0000-18 UNS     |
| 36         | 2.257/2.246 | 2.474        | .890/.870 | 2.125                 | 2.500                 | 1.930       | .125    | .467   | 2.2500-16 UN      | 2.2500-16 UN      |
| 40         | 2.511/2.456 | 2.724        | .890/.870 | 2.125                 | 2.500                 | 2.145       | .125    | .467   | 2.5000-16 UN      | 2.5000-16 UN      |

\* Consult Amphenol, Sidney, NY for availability of shell sizes 44 and 48.

- III 38999
- II
- I
- SJT
- 26482 Matrix 2
- 83723 III Matrix Pyle
- 5015 Crimp Rear Release Matrix
- 26500 Pyle
- Printed Circuit Board
- EMI Filter Transient
- Fiber Optics
- High Speed Contacts
- Options Others

**PART #** Receptacle Shell, Flange Mount, Threaded Coupling.  
To complete, see how to order page 185

| MIL-DTL-5015      | Connector Type | Shell Style | Service Class | Shell Size-Insert Arrangement | Contact Type | Alternate Rotation | Modification Number |
|-------------------|----------------|-------------|---------------|-------------------------------|--------------|--------------------|---------------------|
| <b>Military</b>   | <b>MS</b>      | <b>3452</b> | <i>L</i>      | <i>16S-8</i>                  | <i>P</i>     | <i>W</i>           | <b>NA</b>           |
| <b>Commercial</b> | <b>944</b>     | <b>2</b>    | <i>F</i>      | <i>16S-8</i>                  | <i>P</i>     | <i>W</i>           | <i>xxx</i>          |

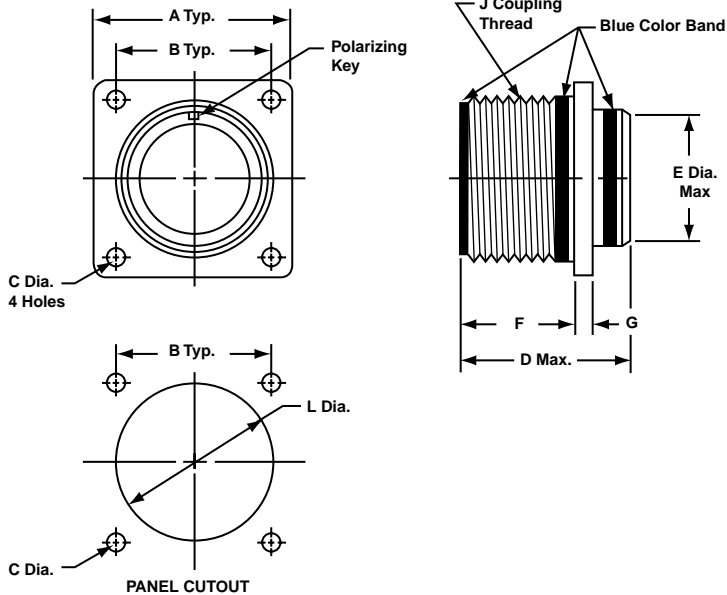

| Shell Size* | A<br>±.031 | B     | C<br>Dia. | D Max.                      |                             | E<br>Dia.<br>±.016 | F         | G<br>±.015 | J<br>Thread<br>Class 2A | L<br>Dia.<br>±.010 |
|-------------|------------|-------|-----------|-----------------------------|-----------------------------|--------------------|-----------|------------|-------------------------|--------------------|
|             |            |       |           | Size<br>16 & 12<br>Contacts | Size<br>8, 4, 0<br>Contacts |                    |           |            |                         |                    |
| 8S          | .875       | .594  | .130/.115 | 1.662                       | —                           | .500               | .578/.562 | .083       | .5000-28 UNEF           | .562               |
| 10S         | 1.000      | .719  | .130/.115 | 1.662                       | —                           | .625               | .578/.562 | .083       | .6250-24 UNEF           | .688               |
| 10SL        | 1.000      | .719  | .130/.115 | 1.662                       | —                           | .625               | .578/.562 | .083       | .6250-24 UNEF           | .688               |
| 12          | 1.094      | .812  | .130/.115 | 1.662                       | —                           | .750               | .765/.750 | .083       | .7500-20 UNEF           | .812               |
| 12S         | 1.094      | .812  | .130/.115 | 1.662                       | —                           | .750               | .578/.562 | .083       | .7500-20 UNEF           | .812               |
| 14          | 1.188      | .906  | .130/.115 | 1.662                       | —                           | .875               | .765/.750 | .083       | .8750-20 UNEF           | .938               |
| 14S         | 1.188      | .906  | .130/.115 | 1.662                       | —                           | .875               | .577/.562 | .083       | .8750-20 UNEF           | .938               |
| 16          | 1.281      | .969  | .130/.115 | 1.662                       | 1.937                       | 1.000              | .765/.750 | .083       | 1.0000-20 UNEF          | 1.062              |
| 16S         | 1.281      | .969  | .130/.115 | 1.662                       | —                           | 1.000              | .577/.562 | .083       | 1.0000-20 UNEF          | 1.062              |
| 18          | 1.375      | 1.062 | .130/.115 | 1.662                       | 1.937                       | 1.062              | .765/.750 | .125       | 1.1250-18 UNEF          | 1.188              |
| 20          | 1.500      | 1.156 | .130/.115 | 1.662                       | 1.937                       | 1.187              | .765/.750 | .125       | 1.2500-18 UNEF          | 1.312              |
| 22          | 1.625      | 1.250 | .130/.115 | 1.662                       | 1.937                       | 1.312              | .765/.750 | .125       | 1.3750-18 UNEF          | 1.438              |
| 24          | 1.750      | 1.375 | .157/.142 | 1.662                       | 1.937                       | 1.437              | .827/.812 | .125       | 1.5000-18 UNEF          | 1.562              |
| 28          | 2.000      | 1.562 | .157/.142 | 1.662                       | 1.937                       | 1.750              | .827/.812 | .125       | 1.7500-18 UNS           | 1.812              |
| 32          | 2.250      | 1.750 | .183/.168 | 1.662                       | 1.937                       | 2.000              | .988/.875 | .125       | 2.0000-18 UNS           | 2.062              |
| 36          | 2.500      | 1.938 | .183/.168 | 1.662                       | 1.937                       | 2.250              | .988/.875 | .125       | 2.2500-16 UN            | 2.312              |
| 40          | 2.750      | 2.188 | .183/.168 | 1.662                       | 1.937                       | 2.500              | .988/.875 | .125       | 2.5000-16 UN            | 2.562              |

\* Consult Amphenol, Sidney, NY for availability of shell sizes 44 and 48.

38999  
SJT I II III

26482  
Matrix 2

83723 III  
Matrix Pyle

5015  
Crimp Rear  
Release Matrix

26500 Pyle

Printed  
Circuit Board

EMI Filter  
Transient

Fiber Optics

High Speed  
Contacts

Options  
Others



# MS3454, MIL-DTL-5015 Crimp Rear Release Jam Nut Receptacle



## PART # Receptacle Shell, Jam Nut Mount, Threaded Coupling To complete, see how to order page 185

| MIL-DTL-5015      | Connector Type | Shell Style | Service Class | Shell Size-Insert Arrangement | Contact Type | Alternate Rotation | Modification Number |
|-------------------|----------------|-------------|---------------|-------------------------------|--------------|--------------------|---------------------|
| <b>Military</b>   | <b>MS</b>      | <b>3454</b> | <i>L</i>      | <i>16S-8</i>                  | <i>P</i>     | <i>W</i>           | <b>NA</b>           |
| <b>Commercial</b> | <b>944</b>     | <b>4</b>    | <i>F</i>      | <i>16S-8</i>                  | <i>P</i>     | <i>W</i>           | <i>xxx</i>          |

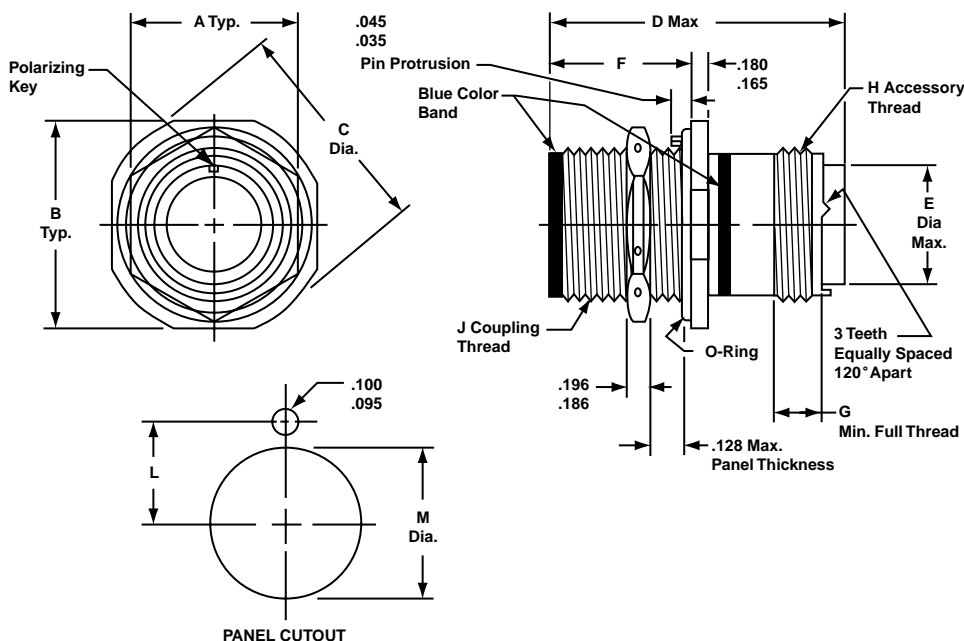

| Shell Size* | A ±.010 | B ±.005 | C Dia. ±.005 | D Max.                |                       | E Dia. Max. | F ±.005 | G Min. | H Thread Class 2A | J Thread Class 2A | Panel Cutout Dimensions |                     |
|-------------|---------|---------|--------------|-----------------------|-----------------------|-------------|---------|--------|-------------------|-------------------|-------------------------|---------------------|
|             |         |         |              | Size 16 & 12 Contacts | Size 8, 4, 0 Contacts |             |         |        |                   |                   | L ±.005                 | M Dia. +.015 - .000 |
| 8S          | .687    | 1.187   | 1.272        | 2.031                 | -                     | .305        | .720    | .290   | .5000-20 UNEF     | .5000-28 UNEF     | .323                    | .505                |
| 10S         | .812    | 1.312   | 1.397        | 2.031                 | -                     | .405        | .720    | .290   | .6250-24 UNEF     | .6250-24 UNEF     | .385                    | .630                |
| 10SL        | .812    | 1.312   | 1.397        | 2.031                 | -                     | .405        | .720    | .290   | .6250-24 UNEF     | .6250-24 UNEF     | .385                    | .630                |
| 12          | .937    | 1.437   | 1.522        | 2.125                 | -                     | .549        | .970    | .290   | .7500-20 UNEF     | .7500-20 UNEF     | .448                    | .755                |
| 12S         | .937    | 1.437   | 1.522        | 2.031                 | -                     | .549        | .720    | .290   | .7500-20 UNEF     | .7500-20 UNEF     | .448                    | .755                |
| 14          | 1.125   | 1.562   | 1.647        | 2.125                 | -                     | .665        | .970    | .290   | .8750-20 UNEF     | .8750-20 UNEF     | .510                    | .880                |
| 14S         | 1.125   | 1.562   | 1.647        | 2.031                 | -                     | .665        | .720    | .290   | .8750-20 UNEF     | .8750-20 UNEF     | .510                    | .880                |
| 16          | 1.250   | 1.687   | 1.772        | 2.125                 | 2.500                 | .790        | .970    | .290   | 1.0000-20 UNEF    | 1.0000-20 UNEF    | .573                    | 1.005               |
| 16S         | 1.250   | 1.687   | 1.772        | 2.031                 | -                     | .790        | .720    | .290   | 1.0000-20 UNEF    | 1.0000-20 UNEF    | .573                    | 1.005               |
| 18          | 1.375   | 1.812   | 1.897        | 2.125                 | 2.500                 | .869        | .970    | .290   | 1.0625-18 UNEF    | 1.1250-18 UNEF    | .635                    | 1.130               |
| 20          | 1.500   | 1.937   | 2.022        | 2.125                 | 2.500                 | .994        | .970    | .290   | 1.1875-18 UNEF    | 1.2500-18 UNEF    | .698                    | 1.255               |
| 22          | 1.625   | 2.156   | 2.241        | 2.125                 | 2.500                 | 1.119       | .970    | .290   | 1.3125-18 UNEF    | 1.3750-18 UNEF    | .760                    | 1.380               |
| 24          | 1.750   | 2.281   | 2.366        | 2.125                 | 2.500                 | 1.244       | .970    | .290   | 1.4375-18 UNEF    | 1.5000-18 UNEF    | .823                    | 1.505               |
| 28          | 2.000   | 2.531   | 2.616        | 2.125                 | 2.500                 | 1.465       | .970    | .467   | 1.7500-18 UNS     | 1.7500-18 UNS     | .948                    | 1.755               |
| 32          | 2.375   | 2.781   | 2.866        | 2.125                 | 2.500                 | 1.715       | .970    | .467   | 2.0000-18 UNS     | 2.0000-18 UNS     | 1.073                   | 2.005               |
| 36          | 2.625   | 3.031   | 3.116        | 2.125                 | 2.500                 | 1.930       | .970    | .467   | 2.2500-16 UN      | 2.2500-16 UN      | 1.198                   | 2.255               |
| 40          | 2.875   | 3.281   | 3.366        | 2.125                 | 2.500                 | 2.145       | .970    | .467   | 2.5000-16 UN      | 2.5000-16 UN      | 1.323                   | 2.505               |

\* Consult Amphenol, Sidney, NY for availability of shell sizes 44 and 48.

III  
II  
I  
SJT  
38999

Matrix 2  
26482

Matrix Pyle  
83723 III

Release Matrix  
5015  
Crimp Rear

26500 Pyle

Printed  
Circuit Board

EMI Filter  
Transient

Fiber Optics

High Speed  
Contacts

Options  
Others

**PART # Plug Shell, Threaded Coupling.**  
**To complete, see how to order page 185**

| MIL-DTL-5015 Connector Type | Shell Style | Service Class | Shell Size—Insert Arrangement | Contact Type | Alternate Rotation | Modification Number |            |
|-----------------------------|-------------|---------------|-------------------------------|--------------|--------------------|---------------------|------------|
| <b>Military</b>             | <b>MS</b>   | <b>3456</b>   | <b>L</b>                      | <b>16S-8</b> | <b>P</b>           | <b>W</b>            | <b>NA</b>  |
| <b>Commercial</b>           | <b>944</b>  | <b>6</b>      | <b>F</b>                      | <b>16S-8</b> | <b>P</b>           | <b>W</b>            | <b>xxx</b> |

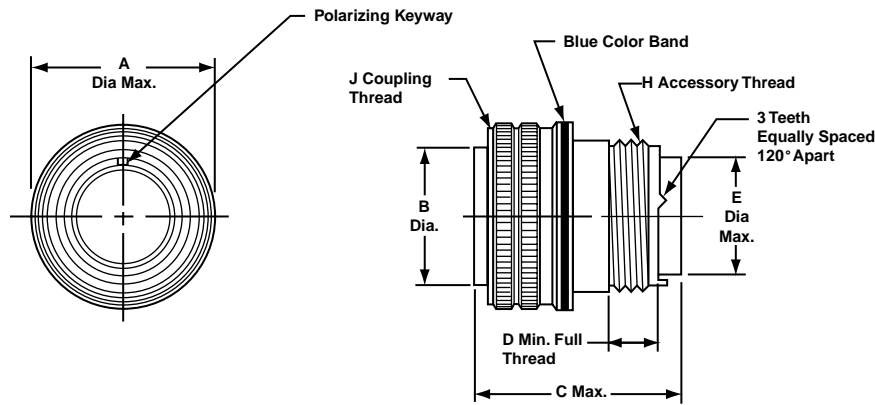

| Shell Size* | A Dia. Max. | B Dia. ±.005 | C Max.                |                       | D Min. | E Dia. Max. | H Thread Class 2A | J Thread Class 2B |
|-------------|-------------|--------------|-----------------------|-----------------------|--------|-------------|-------------------|-------------------|
|             |             |              | Size 16 & 12 Contacts | Size 8, 4, 0 Contacts |        |             |                   |                   |
| 8S          | .844        | .360         | 2.031                 | —                     | .290   | .305        | .5000-20 UNF      | .5000-28 UNEF     |
| 10S         | .969        | .435         | 2.031                 | —                     | .290   | .405        | .6250-24 UNF      | .6250-24 UNEF     |
| 10SL        | .969        | .441**       | 2.031                 | —                     | .290   | .405        | .6250-24 UNF      | .6250-24 UNEF     |
| 12          | 1.062       | .550         | 2.125                 | —                     | .290   | .549        | .7500-20 UNF      | .7500-20 UNEF     |
| 12S         | 1.062       | .550         | 2.031                 | —                     | .290   | .549        | .7500-20 UNF      | .7500-20 UNEF     |
| 14          | 1.156       | .670         | 2.125                 | —                     | .290   | .665        | .8750-20 UNF      | .8750-20 UNEF     |
| 14S         | 1.156       | .670         | 2.031                 | —                     | .290   | .665        | .8750-20 UNF      | .8750-20 UNEF     |
| 16          | 1.250       | .800         | 2.125                 | 2.500                 | .290   | .790        | 1.0000-20 UNF     | 1.0000-20 UNEF    |
| 16S         | 1.250       | .800         | 2.031                 | —                     | .290   | .790        | 1.0000-20 UNF     | 1.0000-20 UNEF    |
| 18          | 1.344       | .925         | 2.125                 | 2.500                 | .290   | .869        | 1.0625-18 UNF     | 1.1250-18 UNEF    |
| 20          | 1.469       | 1.045        | 2.125                 | 2.500                 | .290   | .994        | 1.1875-18 UNF     | 1.2500-18 UNEF    |
| 22          | 1.594       | 1.170        | 2.125                 | 2.500                 | .290   | 1.119       | 1.3125-18 UNF     | 1.3750-18 UNEF    |
| 24          | 1.719       | 1.295        | 2.125                 | 2.500                 | .290   | 1.244       | 1.4375-18 UNF     | 1.5000-18 UNEF    |
| 28          | 1.969       | 1.515        | 2.125                 | 2.500                 | .467   | 1.465       | 1.7500-18 UNS     | 1.7500-18 UNS     |
| 32          | 2.219       | 1.765        | 2.125                 | 2.500                 | .467   | 1.715       | 2.0000-18 UNS     | 2.0000-18 UNS     |
| 36          | 2.469       | 1.975        | 2.125                 | 2.500                 | .467   | 1.930       | 2.2500-16 UN      | 2.2500-16 UN      |
| 40          | 2.719       | 2.225        | 2.125                 | 2.500                 | .467   | 2.145       | 2.5000-16 UN      | 2.5000-16 UN      |

\* Consult Amphenol, Sidney, NY for availability of shell sizes 44 and 48.

\*\* Tolerance on this dimension is +.000 –.006

# MS3459, MIL-DTL-5015 Crimp Rear Release Straight Plug with Self-locking Coupling Nut



## PART # Plug Shell, Self-Locking, Threaded Coupling To complete, see how to order page 185

| MIL-DTL-5015      | Connector Type | Shell Style | Service Class | Shell Size-Insert Arrangement | Contact Type | Alternate Rotation | Modification Number |
|-------------------|----------------|-------------|---------------|-------------------------------|--------------|--------------------|---------------------|
| <b>Military</b>   | <b>MS</b>      | <b>3459</b> | <i>L</i>      | <i>16S-8</i>                  | <i>P</i>     | <i>W</i>           | <b>NA</b>           |
| <b>Commercial</b> | <b>981</b>     | <b>6</b>    | <i>F</i>      | <i>16S-8</i>                  | <i>P</i>     | <i>W</i>           | xxx                 |

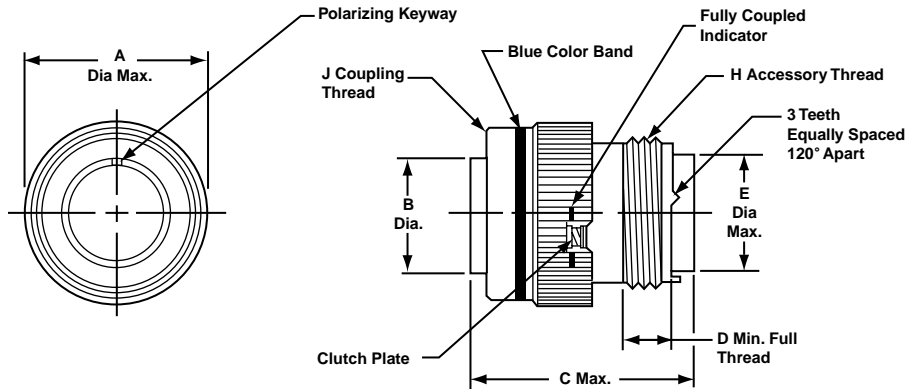

| Shell Size* | A Dia. Max. | B Dia. ±.005 | C Max.                |                       | D Min. | E Dia. Max. | H Thread Class 2A | J Thread Class 2B |
|-------------|-------------|--------------|-----------------------|-----------------------|--------|-------------|-------------------|-------------------|
|             |             |              | Size 16 & 12 Contacts | Size 8, 4, 0 Contacts |        |             |                   |                   |
| 8S          | .963        | .360         | 1.510                 | -                     | .290   | .305        | .5000-20 UNEF     | .5000-28 UNEF     |
| 10S         | 1.088       | .435         | 1.510                 | -                     | .290   | .405        | .6250-24 UNEF     | .6250-24 UNEF     |
| 10SL        | 1.088       | .441**       | 1.510                 | -                     | .290   | .405        | .6250-24 UNEF     | .6250-24 UNEF     |
| 12          | 1.213       | .550         | 1.780                 | -                     | .290   | .549        | .7500-20 UNEF     | .7500-20 UNEF     |
| 12S         | 1.213       | .550         | 1.510                 | -                     | .290   | .549        | .7500-20 UNEF     | .7500-20 UNEF     |
| 14          | 1.358       | .670         | 1.780                 | -                     | .290   | .665        | .8750-20 UNEF     | .8750-20 UNEF     |
| 14S         | 1.358       | .670         | 1.510                 | -                     | .290   | .665        | .8750-20 UNEF     | .8750-20 UNEF     |
| 16          | 1.463       | .800         | 1.780                 | 2.500                 | .290   | .790        | 1.0000-20 UNEF    | 1.0000-20 UNEF    |
| 16S         | 1.463       | .800         | 1.510                 | -                     | .290   | .790        | 1.0000-20 UNEF    | 1.0000-20 UNEF    |
| 18          | 1.588       | .925         | 1.850                 | 2.500                 | .290   | .869        | 1.0625-18 UNEF    | 1.1250-18 UNEF    |
| 20          | 1.713       | 1.045        | 1.850                 | 2.500                 | .290   | .994        | 1.1875-18 UNEF    | 1.2500-18 UNEF    |
| 22          | 1.788       | 1.170        | 1.850                 | 2.500                 | .290   | 1.119       | 1.3125-18 UNEF    | 1.3750-18 UNEF    |
| 24          | 1.963       | 1.295        | 1.850                 | 2.500                 | .290   | 1.244       | 1.4375-18 UNEF    | 1.5000-18 UNEF    |
| 28          | 2.213       | 1.515        | 1.850                 | 2.500                 | .467   | 1.465       | 1.7500-18 UNS     | 1.7500-18 UNS     |
| 32          | 2.463       | 1.765        | 1.850                 | 2.500                 | .467   | 1.715       | 2.0000-18 UNS     | 2.0000-18 UNS     |
| 36          | 2.713       | 1.975        | 1.850                 | 2.500                 | .467   | 1.930       | 2.2500-16 UN      | 2.2500-16 UN      |
| 40          | 2.963       | 2.225        | 1.850                 | 2.500                 | .467   | 2.145       | 2.5000-16 UN      | 2.5000-16 UN      |

\* Consult Amphenol, Sidney, NY for availability of shell sizes 44 and 48.  
\*\* Tolerance on this dimension is +.000 -.006

III  
II  
I  
SJT  
38999

26482  
Matrix 2

83723 III  
Matrix  
Pyle

5015  
Crimp Rear  
Release Matrix

26500 Pyle

Printed  
Circuit Board

EMI Filter  
Transient

Fiber Optics

High Speed  
Contacts

Options  
Others

**PART # Plug Shell, Quick Disconnect, Push-pull Coupling**  
To complete, see how to order page 185

| MIL-DTL-5015 Connector Type | Shell Style | Service Class | Shell Size-Insert Arrangement | Contact Type | Alternate Rotation | Modification Number |
|-----------------------------|-------------|---------------|-------------------------------|--------------|--------------------|---------------------|
| Commercial                  | 981         | L             | 16S-8                         | P            | W                  | xxx                 |
| Commercial                  | 981         | F             | 16S-8                         | P            | W                  | xxx                 |

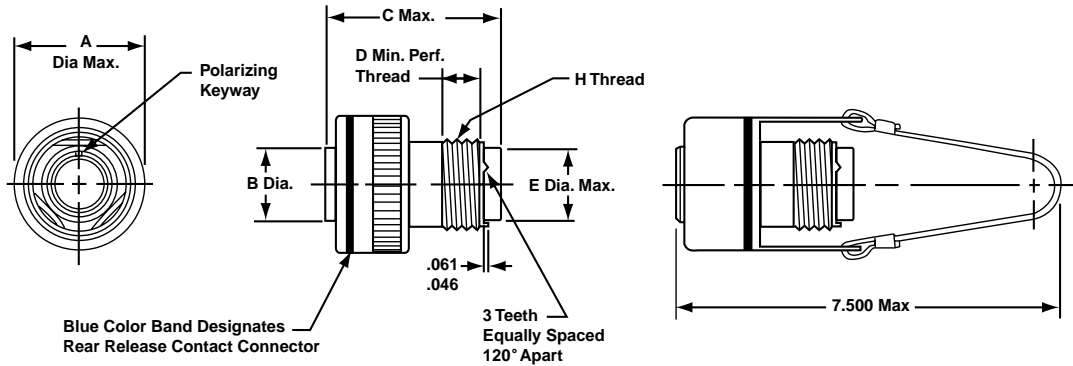

9818 Connector

9817 Connector with Lanyard

| Shell Size* | A Dia. Max. | B Dia. | C Max.                |                       | D Min. | E Dia. Max. | H Thread Class 2A | Amphenol/Matrix Part Number for Adapter Ring |
|-------------|-------------|--------|-----------------------|-----------------------|--------|-------------|-------------------|--|
|             |             |        | Size 16 & 12 Contacts | Size 8, 4, 0 Contacts |        |             |                   |  |
| 8S          | 1.087       | .360   | 2.031                 | —                     | .290   | .305        | .5000-20 UNF      | 2500-008-0X08                                |
| 10S         | 1.224       | .435   | 2.031                 | —                     | .290   | .405        | .6250-24 UNEF     | 2500-008-0X10                                |
| 10SL        | 1.224       | .441   | 2.031                 | —                     | .290   | .405        | .6250-24 UNEF     | 2500-008-0X10                                |
| 12          | 1.355       | .550   | 2.125                 | —                     | .290   | .549        | .7500-20 UNEF     | 2500-008-0X12                                |
| 12S         | 1.355       | .550   | 2.031                 | —                     | .290   | .549        | .7500-20 UNEF     | 2500-008-0X13                                |
| 14          | 1.482       | .670   | 2.125                 | —                     | .290   | .665        | .8750-20 UNEF     | 2500-008-0X14                                |
| 14S         | 1.482       | .670   | 2.031                 | —                     | .290   | .665        | .8750-20 UNEF     | 2500-008-0X15                                |
| 16          | 1.609       | .800   | 2.125                 | 2.500                 | .290   | .790        | 1.0000-20 UNEF    | 2500-008-0X16                                |
| 16S         | 1.609       | .800   | 2.031                 | —                     | .290   | .790        | 1.0000-20 UNEF    | 2500-008-0X17                                |
| 18          | 1.817       | .925   | 2.125                 | 2.500                 | .290   | .869        | 1.0625-18 UNEF    | 2500-008-0X18                                |
| 20          | 1.942       | 1.045  | 2.125                 | 2.500                 | .290   | .994        | 1.1875-18 UNEF    | 2500-008-0X20                                |
| 22          | 2.075       | 1.170  | 2.125                 | 2.500                 | .290   | 1.119       | 1.3125-18 UNEF    | 2500-008-0X22                                |
| 24          | 2.203       | 1.295  | 2.125                 | 2.500                 | .290   | 1.244       | 1.4375-18 UNEF    | 2500-008-0X24                                |
| 28          | 2.516       | 1.515  | 2.125                 | 2.500                 | .467   | 1.465       | 1.7500-18 UNS     | 2500-008-0X28                                |
| 32          | 2.735       | 1.765  | 2.125                 | 2.500                 | .467   | 1.715       | 2.0000-18 UNS     | 2500-008-0X32                                |
| 36          | 3.015       | 1.975  | 2.125                 | 2.500                 | .467   | 1.930       | 2.2500-16 UN      | 2500-008-0X36                                |
| 40          | 3.306       | 2.225  | 2.125                 | 2.500                 | .467   | 2.145       | 2.5000-16 UN      | 2500-008-0X40                                |

\* Consult Amphenol, Sidney, NY for availability of shell sizes 44 and 48.

**Receptacle Adapter Ring**

Required to mate the quick disconnect plug with receptacle. Not furnished with the quick disconnect plug and must be ordered separately.

Note: Use Locktite Material on the threads for a permanent installation to the shell.

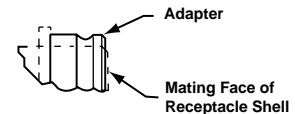

**How to Order Adapter Ring**

**Part Number**

**2500-008-0 X XX**

Shell Size (varies from connector shell size designation, see last column of table at left)

Finish

- 0 - Electroless Nickel
- 1 - Black Anodize
- 2 - Cadmium/Olive Drab
- 3 - Stainless Steel, Passivated

38999  
SJT I II III

26482  
Matrix 2

83723 III  
Matrix Pyle

5015  
Crimp Rear Release Matrix

26500 Pyle

Printed  
Circuit Board

EMI Filter  
Transient

Fiber Optics

High Speed  
Contacts

Options  
Others

# Amphenol® Matrix 5015 Connector With RADSOK® Contacts



## For High Power Applications

- Mil-spec qualified, environmental Matrix MIL-DTL-5015 connectors with improved sealing
- Completely environmentally sealed with contact seals, gaskets, wire seals and insert-to-shell seals
- Special design enhanced with RADSOK contacts in the plug instead of standard rear release crimp contacts
- All the shell styles and finishes of the Matrix 5015 family are available, including firewall styles and non-decoupling styles

RADSOK contacts provide high amperage capability with minimal voltage loss and low insertion forces.

The RADSOK contact has a hyperbolic, stamped grid configuration with the socket circular. As a male pin is inserted, axial members in the female socket deflect, enabling high current flow across the connection with minimal voltage loss.

See pages 419-421 for more information on RADSOK contacts.



**RADSOK**

III  
II  
I  
SJT  
38999

26482  
Matrix 2

83723 III  
Matrix  
Pyle

5015  
Crimp Rear  
Release Matrix

26500 Pyle

Printed  
Circuit Board

EMI Filter  
Transient

Fiber Optics

High Speed  
Contacts

Options  
Others

### MS/STANDARD CRIMP REAR RELEASE CONTACTS

| Contact Size | Wire Range |                 | Socket Contacts      |                             | Pin Contacts         |                             |
|--------------|------------|-----------------|----------------------|-----------------------------|----------------------|-----------------------------|
|              | AWG        | mm <sup>2</sup> | Military Part Number | Amphenol/Matrix Part Number | Military Part Number | Amphenol/Matrix Part Number |
|              |            |                 |                      |                             |                      |                             |
| 16S*         | 20-16      | 0.5-1.4         | M39029/30-217        | M5100-033-1601L             | M39029/29-212        | M5000-029-0016L             |
| 16           | 20-16      | 0.5-1.4         | M39029/30-218        | M5100-033-1602L             | M39029/29-212        | M5000-029-0016L             |
| 12           | 14-12      | 2-3             | M39029/30-219        | M5100-033-0012              | M39029/29-213        | M5000-029-0012              |
| 8            | 10-8†      | 5-8.5           | M39029/30-220        | M5100-033-0008              | M39029/29-214        | M5000-029-0008              |
| 4            | 6-4†       | 13-21           | M39029/30-221        | M5100-033-0004              | M39029/29-215        | M5000-029-0004              |
| 0            | 2-0†       | 34-60           | M39029/30-222        | M5100-033-0000              | M39029/29-216        | M5000-029-0000              |

\* Shorter wire barrel

Note: For information on thermocouple contacts, consult Amphenol, Sidney, NY.

† Use MS3348 bushing kit to accommodate smaller wire.

### CONTACT CURRENT RATING AND RETENTION

| Contact Size** | Current Rating |                         | Contact Retention |       |
|----------------|----------------|-------------------------|-------------------|-------|
|                | Amperes Max.   | Voltage Drop Millivolts | Axial Load        |       |
|                |                |                         | lb.               | N     |
| 16             | 13             | 50                      | 25                | 111.2 |
| 12             | 23             | 50                      | 30                | 133.4 |
| 8              | 46             | 25                      | 50                | 222.4 |
| 4              | 80             | 14                      | 60                | 266.9 |
| 0              | 150            | 12                      | 75                | 333.6 |

\*\* Organize individual circuits to maintain heat rise within operating temperature requirements.

### SEALING PLUGS

| Contact Size | Sealing Plugs        |                             |
|--------------|----------------------|-----------------------------|
|              | Military Part Number | Amphenol/Matrix Part Number |
| 16S          | MS27488-16-1         | 10-405996-161               |
| 16           | MS27488-16-1         | 10-405996-161               |
| 12           | MS27488-12-1         | 10-405996-121               |
| 8            | MS27488-8-1          | 10-405996-081               |
| 4            | MS27488-4-1          | 10-405996-041               |
| 0            | MS27488-0-1          | 10-405996-001               |

### CRIMPING TOOLS

| Contact Size | Wire Range |                 | Finished Wire Dia. Range |            | Color Code  | Crimping Tool Part Number | Turret or Positioner Part Number |
|--------------|------------|-----------------|--------------------------|------------|-------------|---------------------------|----------------------------------|
|              | AWG        | mm <sup>2</sup> | Inch                     | mm         |             |                           |                                  |
| 16S          | 20-16      | 0.5-1.4         | .053-.103                | 1.34-2.62  | Red/White   | M22520/1-01               | M22520/1-02                      |
| 16           | 20-16      | 0.5-1.4         | .053-.103                | 1.34-2.62  | Blue/White  | M22520/1-01               | M22520/1-02                      |
| 12           | 14-12      | 2-3             | .085-.158                | 2.15-4.01  | Yell./White | M22520/1-01               | M22520/1-02                      |
| 8            | 10-8       | 5-8.5           | .132-.255                | 3.35-6.48  | White/Red   | M22520/23-01              | M22520/23-02                     |
| 4            | 6-4        | 13-21           | .237-.370                | 6.01-9.40  | White/Blue  | M22520/23-01              | M22520/23-04                     |
| 0            | 2-0        | 34-60           | .360-.550                | 9.14-13.97 | White/Yell. | M22520/23-01              | M22520/23-05                     |

### INSERTION/REMOVAL TOOLS

| Contact Size | Color Code   | Military Part Number | Amphenol/Matrix Part Number |
|--------------|--------------|----------------------|-----------------------------|
| 16           | Blue/White   | M81969/14-03         | 10-538988-016               |
| 12           | Yellow/White | M81969/14-04         | 10-538988-012               |
| 8            | Red          | M81969/14-06         | 6500-018-0008               |
| 4            | Blue         | M81969/14-07         | 6500-018-0004               |
| 0            | Yellow       | M81969/14-08         | 6500-018-0000               |

Amphenol installation instructions, L-2106, gives information on insertion, removal and crimping of contacts for Matrix MIL-DTL-5015 connectors.

38999  
SJT I II III

26482  
Matrix 2

83723 III  
Matrix Pyle

5015  
Crimp Rear Release Matrix

26500 Pyle

Printed  
Circuit Board

EMI Filter  
Transient

Fiber Optics

High Speed  
Contacts

Options  
Others



### PLUG PROTECTION CAP 10-329393-XX\*

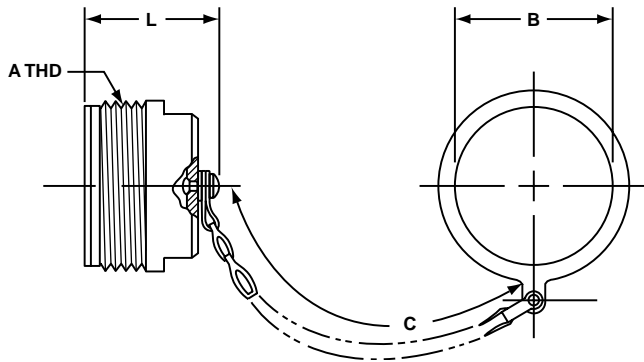

| Assembly Number | A Thread Class 2A | B Dia. +.010 - .000 | C Approx. | L Max. |
|-----------------|-------------------|---------------------|-----------|--------|
| 10-329393-10    | .625-24UNEF       | .641                | 3.5       | 1.312  |
| 10-329393-11    | .625-24UNEF       | .641                | 3.5       | 1.312  |
| 10-329393-12    | .750-20UNEF       | .766                | 3.5       | 1.500  |
| 10-329393-14    | .875-20UNEF       | .891                | 3.5       | 1.500  |
| 10-329393-16    | 1.000-20UNEF      | 1.016               | 3.5       | 1.500  |
| 10-329393-18    | 1.125-18UNEF      | 1.141               | 3.5       | 1.500  |
| 10-329393-20    | 1.250-18UNEF      | 1.266               | 4.0       | 1.500  |
| 10-329393-22    | 1.375-18UNEF      | 1.391               | 4.0       | 1.500  |
| 10-329393-24    | 1.500-18UNEF      | 1.641               | 4.5       | 1.500  |
| 10-329393-28    | 1.750-18UNS       | 1.891               | 4.5       | 1.500  |
| 10-329393-32    | 2.000-18UNS       | 2.078               | 5.0       | 1.500  |
| 10-329393-36    | 2.250-16UN        | 2.328               | 5.0       | 1.500  |
| 10-329393-40    | 2.500-16UN        | 2.641               | 5.0       | 1.500  |
| 10-329393-44    | 2.750-16UN        | 2.891               | 6.0       | 1.500  |

### PLUG PROTECTION CAP 10-229125-XX\*

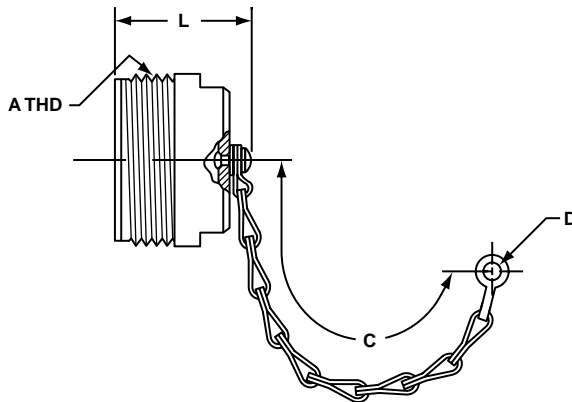

| Assembly Number | A Thread Class 2A | C Approx. | D Ref. | L Max. |
|-----------------|-------------------|-----------|--------|--------|
| 10-229125-10    | .625-24NEF        | 3.0       | .140   | 1.233  |
| 10-229125-12    | .750-20UNEF       | 3.5       | .140   | 1.421  |
| 10-229125-14    | .875-20UNEF       | 3.5       | .140   | 1.421  |
| 10-229125-16    | 1.000-20UNEF      | 3.5       | .140   | 1.421  |
| 10-229125-18    | 1.125-18NEF       | 3.5       | .140   | 1.421  |
| 10-229125-20    | 1.250-18NEF       | 3.5       | .193   | 1.421  |
| 10-229125-22    | 1.375-18NEF       | 3.5       | .193   | 1.421  |
| 10-229125-24    | 1.500-18NEF       | 4.5       | .193   | 1.421  |
| 10-229125-28    | 1.750-18NS        | 4.5       | .193   | 1.421  |
| 10-229125-32    | 2.000-18NS        | 5.0       | .193   | 1.421  |
| 10-229125-36    | 2.250-16UN        | 5.0       | .193   | 1.421  |
| 10-229125-40    | 2.500-16UN        | 5.0       | .193   | 1.421  |

### PLUG PROTECTION CAP MS25042-XXDA\*

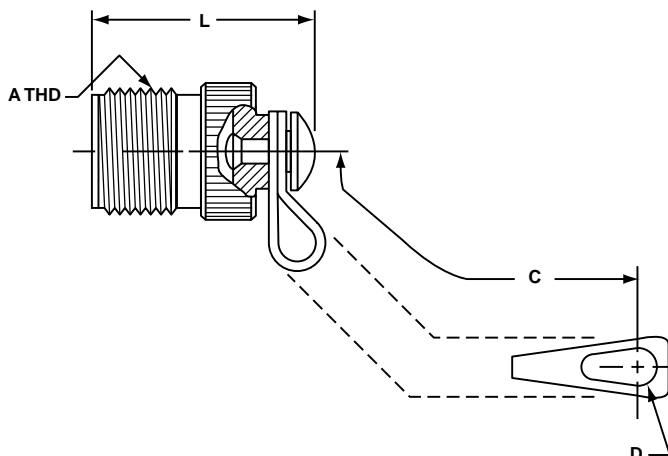

| MS Number    | A Thread Class 2A | B Dia. +.010 - .005 | C Approx. | L Max. |
|--------------|-------------------|---------------------|-----------|--------|
| MS25042-8DA  | .500-28UNEF       | .156                | 4.00      | .969   |
| MS25042-10DA | .625-24UNEF       | .156                | 4.00      | .969   |
| MS25042-12DA | .750-20UNEF       | .156                | 4.50      | 1.156  |
| MS25042-14DA | .875-20UNEF       | .156                | 4.50      | 1.156  |
| MS25042-16DA | 1.000-20UNEF      | .156                | 4.50      | 1.156  |
| MS25042-18DA | 1.125-18UNEF      | .156                | 4.50      | 1.156  |
| MS25042-20DA | 1.250-18UNEF      | .187                | 5.00      | 1.156  |
| MS25042-22DA | 1.375-18UNEF      | .187                | 5.00      | 1.156  |
| MS25042-24DA | 1.500-18UNEF      | .187                | 5.50      | 1.156  |
| MS25042-28DA | 1.750-18UNS       | .187                | 7.75      | 1.156  |
| MS25042-32DA | 2.000-18UNS       | .218                | 7.75      | 1.156  |
| MS25042-36DA | 2.250-16UN        | .218                | 7.75      | 1.156  |
| MS25042-40DA | 2.500-16UN        | .218                | 7.75      | 1.156  |

\* Protective caps are illustrated with sash chains and are available with beaded chains or without chains. Optional terminations are also available. Consult Amphenol, Sidney, NY when ordering.

III  
II  
I  
SJT  
38999

Matrix 2  
26482

Matrix  
Pyle  
83723 III

5015  
Crimp Rear  
Release Matrix

26500 Pyle

Printed  
Circuit Board

EMI Filter  
Transient

Fiber Optics

High Speed  
Contacts

Options  
Others

- 38999 SJT I II III
- 26482 Matrix 2
- 83723 III Pyle Matrix
- 5015 Crimp Rear Release Matrix
- 26500 Pyle Printed Circuit Board
- EMI Filter Transient
- Fiber Optics
- High Speed Contacts
- Options Others

| Assembly Number | A Thread Class 2B | B Dia. Min. | C Approx. | D Dia. Max. | L Max. |
|-----------------|-------------------|-------------|-----------|-------------|--------|
| 10-329394-10    | .625-24UNEF       | .641        | 3.5       | .875        | .793   |
| 10-329394-12    | .750-20UNEF       | .766        | 3.5       | 1.000       | .793   |
| 10-329394-14    | .875-20UNEF       | .891        | 3.5       | 1.125       | .793   |
| 10-329394-16    | 1.000-20UNEF      | 1.016       | 3.5       | 1.250       | .793   |
| 10-329394-18    | 1.125-18UNEF      | 1.141       | 3.5       | 1.375       | 1.024  |
| 10-329394-20    | 1.250-18UNEF      | 1.266       | 4.0       | 1.500       | 1.024  |
| 10-329394-22    | 1.375-18UNEF      | 1.391       | 4.0       | 1.625       | 1.024  |
| 10-329394-24    | 1.500-18UNEF      | 1.641       | 4.5       | 1.750       | 1.024  |
| 10-329394-28    | 1.750-18UNS       | 1.891       | 4.5       | 2.000       | 1.024  |
| 10-329394-32    | 2.000-18UNS       | 2.078       | 5.0       | 2.250       | 1.024  |
| 10-329394-36    | 2.250-16UN        | 2.328       | 5.0       | 2.500       | 1.024  |
| 10-329394-40    | 2.500-16UN        | 2.641       | 5.0       | 2.656       | 1.024  |
| 10-329394-44    | 2.750-16UN        | 2.891       | 6.0       | 2.938       | 1.024  |

### RECEPTACLE PROTECTION CAP 10-329394-XX\*

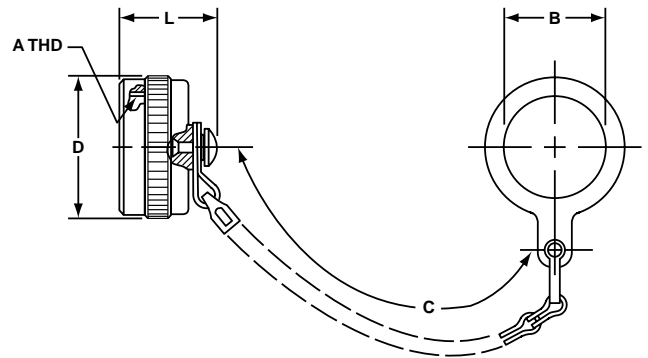

| Assembly Number | A Thread Class 2B | B Ref. | C Approx. | D Dia. Max. | L Max. |
|-----------------|-------------------|--------|-----------|-------------|--------|
| 10-422905-103   | .625-24UNEF       | .140   | 3.0       | .875        | .812   |
| 10-422905-123   | .750-20UNEF       | .140   | 3.5       | 1.000       | .812   |
| 10-422905-143   | .875-20UNEF       | .140   | 3.5       | 1.125       | .812   |
| 10-422905-163   | 1.000-20UNEF      | .140   | 3.5       | 1.250       | .812   |
| 10-422905-183   | 1.125-18UNEF      | .193   | 3.5       | 1.375       | 1.031  |
| 10-422905-203   | 1.250-18UNEF      | .193   | 4.0       | 1.500       | 1.031  |
| 10-422905-223   | 1.375-18UNEF      | .193   | 4.0       | 1.625       | 1.031  |
| 10-422905-243   | 1.500-18UNEF      | .193   | 4.5       | 1.750       | 1.031  |
| 10-422905-283   | 1.750-18UNS       | .193   | 4.5       | 2.000       | 1.031  |
| 10-422905-323   | 2.000-18UNS       | .193   | 5.0       | 2.250       | 1.031  |
| 10-422905-363   | 2.250-16UN        | .193   | 5.0       | 2.500       | 1.031  |
| 10-422905-403   | 2.500-16UN        | .193   | 5.0       | 2.656       | 1.031  |

### RECEPTACLE PROTECTION CAP 10-422905-XXX\*

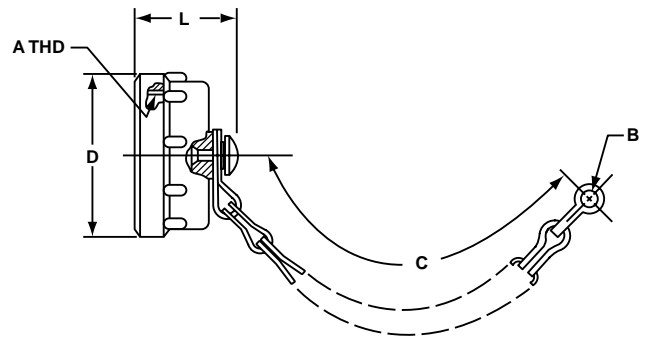

| MS Number    | A Thread Class 2B | B +.010 - .005 | C Approx. | D Dia. Max. | L Max. |
|--------------|-------------------|----------------|-----------|-------------|--------|
| MS25043-8DA  | .500-28UNEF       | .140           | 4.00      | .688        | .750   |
| MS25043-10DA | .625-24UNEF       | .140           | 4.00      | .815        | .750   |
| MS25043-12DA | .750-20UNEF       | .140           | 4.50      | 1.000       | .750   |
| MS25043-14DA | .875-20UNEF       | .140           | 4.50      | 1.125       | .750   |
| MS25043-16DA | 1.000-20UNEF      | .140           | 4.50      | 1.188       | .750   |
| MS25043-18DA | 1.125-18UNEF      | .140           | 4.50      | 1.344       | .750   |
| MS25043-20DA | 1.250-18UNEF      | .140           | 5.00      | 1.469       | .750   |
| MS25043-22DA | 1.375-18UNEF      | .140           | 5.00      | 1.594       | .750   |
| MS25043-24DA | 1.500-18UNEF      | .171           | 5.50      | 1.719       | .750   |
| MS25043-28DA | 1.750-18UNS       | .171           | 7.75      | 1.969       | .812   |
| MS25043-32DA | 2.000-18UNS       | .187           | 7.75      | 2.219       | .812   |
| MS25043-36DA | 2.250-16UN        | .187           | 7.75      | 2.469       | .812   |
| MS25043-40DA | 2.500-16UN        | .187           | 7.75      | 2.719       | .812   |

### RECEPTACLE PROTECTION CAP MS25043-XXDA\*

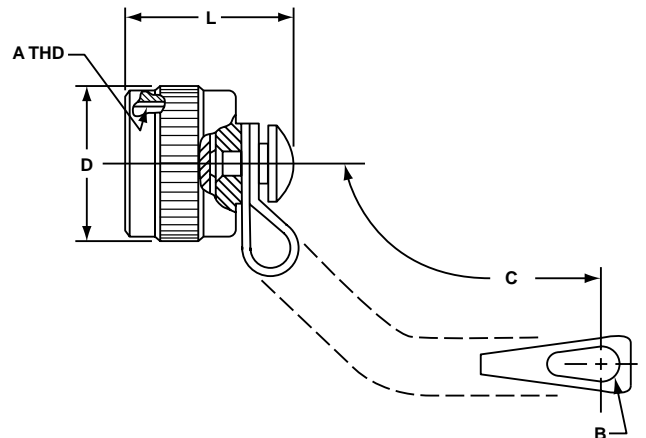

\* Protective caps are illustrated with sash chains and are available with beaded chains or without chains. Optional terminations are also available. Consult Amphenol, Sidney, NY when ordering.

### 10-70500 RECEPTACLE DUST CAP for external threads

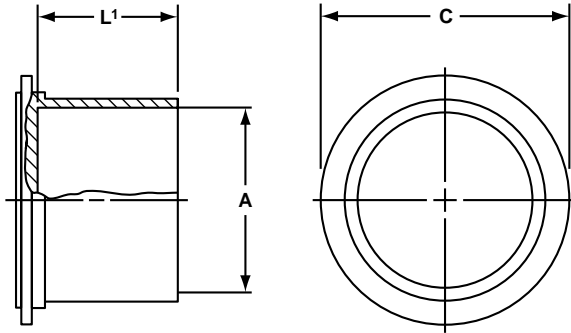

| MS Shell Size | Order Number | A Dia. Nominal Thread | C Dia. ±.031 | L <sup>1</sup> ±.062 |
|---------------|--------------|-----------------------|--------------|----------------------|
| 8S            | 10-70500-8   | .500                  | .750         | .500                 |
| 10S           | 10-70500-10  | .625                  | .875         | .500                 |
| 10SL          | 10-70500-10  | .625                  | .875         | .500                 |
| 12S           | 10-70500-12  | .750                  | 1.000        | .500                 |
| 12            | 10-70500-12  | .750                  | 1.000        | .500                 |
| 14S           | 10-70500-14  | .875                  | 1.125        | .500                 |
| 14            | 10-70500-14  | .875                  | 1.125        | .500                 |
| 16S           | 10-70500-16  | 1.000                 | 1.250        | .500                 |
| 16            | 10-70500-16  | 1.000                 | 1.250        | .500                 |
| 18            | 10-70500-18  | 1.125                 | 1.375        | .562                 |
| 20            | 10-70500-20  | 1.250                 | 1.500        | .562                 |
| 22            | 10-70500-22  | 1.375                 | 1.625        | .562                 |
| 24            | 10-70500-24  | 1.500                 | 1.750        | .562                 |
| 28            | 10-70500-28  | 1.750                 | 1.938        | .562                 |
| 32            | 10-70500-32  | 2.000                 | 2.250        | .562                 |
| 36            | 10-70500-36  | 2.250                 | 2.500        | .625                 |
| 40            | 10-70500-40  | 2.500                 | 2.750        | .625                 |

### 10-70506 PLUG DUST CAP for internal threads

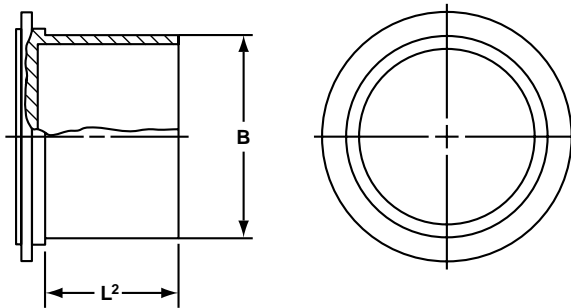

| MS Shell Size | Order Number | B Dia. Min. | L <sup>2</sup> ±.125 |
|---------------|--------------|-------------|----------------------|
| 8S            | 10-70506-8S  | .469        | .625                 |
| 10S           | 10-70506-10S | .587        | .625                 |
| 10SL          | 10-70506-10S | .587        | .625                 |
| 12S           | 10-70506-12  | .704        | .625                 |
| 12            | 10-70506-12  | .704        | .625                 |
| 14S           | 10-70506-14  | .828        | .625                 |
| 14            | 10-70506-14  | .828        | .625                 |
| 16S           | 10-70506-16  | .953        | .625                 |
| 16            | 10-70506-16  | .953        | .625                 |
| 18            | 10-70506-18  | 1.072       | .625                 |
| 20            | 10-70506-20  | 1.197       | .625                 |
| 22            | 10-70506-22  | 1.322       | .625                 |
| 24            | 10-70506-24  | 1.447       | .625                 |
| 28            | 10-70506-28  | 1.697       | .625                 |
| 32            | 10-70506-32  | 1.947       | .625                 |
| 36            | 10-70506-36  | 2.190       | .625                 |
| 40            | 10-70506-40  | 2.440       | .625                 |

III  
II  
I  
SJT  
38999

Matrix 2  
26482

Matrix  
Pyle  
83723 III

Release Matrix  
Crimp Rear  
5015

26500 Pyle

Printed  
Circuit Board

EMI Filter  
Transient

Fiber Optics

High Speed  
Contacts

Options  
Others

38999

SJT

I

II

III

26482

Matrix 2

83723 III

Matrix Pyle

5015

Crimp Rear  
Release Matrix

26500 Pyle

Printed  
Circuit Board

EMI Filter  
Transient

Fiber Optics

High Speed  
Contacts

Options  
Others



**MS/Standard 3100 Series, MIL-5015 Type Connectors**

**MIL-DTL-5015 and MIL-5015 Type Standard Circular Connectors with solder or crimp (non-rear release) contacts**

Amphenol has long been the accepted leader in providing MS Standard MIL-5015 type connectors. These connectors represent well-proven electrical capability at an economical cost for most equipment where durability is important.

The MS/Standard family of connectors (3100 Series) is a very broad range of product with the following features:

- Medium to heavy weight cylindrical with resilient inserts
- Environmental resistant
- Threaded couplings, single key/keyway shell polarization
- Operating voltage to 3000 VAC (RMS) at sea level
- 5 shell styles, 19 shell sizes, 280 contact arrangements
- Solder or crimp contacts (non-rear-release type), sizes 16–0 accepting 22–0 AWG
- Coaxial or thermocouple contact options
- Alternate insert positioning
- Hermetic configurations available
- Zinc alloy plating (cadmium-free) available

The 3100 Series has five classes of connectors to meet different requirements. Within these connector styles, MIL-C-5015 has been replaced as follows: Environmental classes F and R are updated to and produced in strict accordance to MIL-DTL-5015. Classes A, C and E are still produced, but are no longer listed on the qualified products listing (QPL). Class designations and brief descriptions are as follows:

- A – Solid Shell – for general, non-environmental applications.
- C – Pressurized – for use on pressurized bulkheads or pressure barriers; limits air leakage regardless of type and class of plug mated with them.
- E/F – Environmental Resisting with Strain Relief – designed for applications where the connector will be exposed to moisture, vibration, and rapid changes in pressure and temperature.
- R – Lightweight Environmental Resisting – shorter in length, lighter in weight than the E & F classes, the MS-R offers a high degree of reliability under adverse conditions: recommended for new design applications.

Ask for Amphenol catalog 12-020 which gives detailed information on this family of connectors or visit [www.amphenol-industrial.com](http://www.amphenol-industrial.com)

**MIL-5015 Modifications**

In order to supplement standard MS shell styles and provide a greater variety of styles for the electrical connector user, there are several MS and MS Modified cylindrical connectors offered by Amphenol. These types include flange mount plugs, thru bulkhead receptacles, jam nut receptacles, connectors for potting and connectors designed specifically to terminate jacketed cable. Ask for Amphenol catalog 12-021 for detailed information or visit [www.amphenol-industrial.com](http://www.amphenol-industrial.com).

**97 Series, MIL-5015 Type Connectors**

The low cost, general duty connector used extensively in the machine tool industry, welding industry and numerous other industrial applications, is the Amphenol® 97 Series. Offered in non-environmental styles, these connectors have hard dielectric inserts and threaded coupling. They are Underwriters Laboratories Recognized and Canadian Standards Association Certified.

Recent addition to this family is the 97E environmental styles, still an economical choice. The 97E can be used in a variety of industrial applications where environmental sealing is required, such as automotive and robotics.

Ask for Amphenol catalog 12-022 for detailed information or visit [www.amphenol-industrial.com](http://www.amphenol-industrial.com).



**97 Series, MIL-5015 Type Connectors**



# Amphenol MIL-DTL-26500, Pyle®

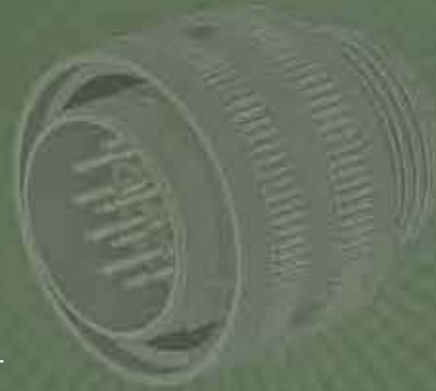

## TABLE OF CONTENTS

### MIL-DTL-26500, Pyle® Connectors

- Table of Contents . . . . . 199
- Product Introduction and Options . . . . . 200
- Class Descriptions, Features, Specifications . . . . . 201, 202
- Insert Arrangements, Alternate Keying . . . . . 203, 204

### MIL-DTL-26500 Aluminum/Stainless Steel Shell Styles:

- Threaded Coupling & Bayonet Coupling Quick Reference Charts . . . . . 205
- Ratchet Lock Coupling Quick Reference Charts . . . . . 206
- How to Order, Threaded/Bayonet, Military & Commercial . . . . . 207, 208
- Square Flange Mounted Receptacle, Threaded MS24264, Pyle ZZY . . . . . 209
- Single Hole (D-hole) Mounted Receptacle, Threaded MS24265, Pyle ZZY . . . . . 210
- Straight Plug, Threaded MS24266, Pyle ZZY . . . . . 211
- Square Flange Mounted Receptacle Bayonet, MS24264, Pyle ZZW . . . . . 212
- Single Hole (D-hole) Mounted Receptacle, Bayonet MS24265, Pyle ZZW . . . . . 213
- Straight Plug, Bayonet MS24266, Pyle ZZW . . . . . 214
- Ratchet Lock Plug/New Non-Decoupling Plug, Pyle ZZY . . . . . 215
- Ratchet Lock Plug/New Non-Decoupling Plug, Mating Flange Mounted Receptacle Pyle ZZY . . . . . 216

### MIL-DTL-26500 Firewall Class K Stainless Steel Shell Styles:

- Threaded Coupling & Bayonet Coupling Quick Reference Charts . . . . . 217
- How to Order Firewall Class K . . . . . 218
- How to Order Firewall Class K, Boeing Company . . . . . 219
- Square Flange Mounted Receptacle, Firewall MS27613K, Pyle FPK Threaded MS27613K, Pyle® FYL Bayonet . . . . . 220
- Single Hole (D-hole) Mounted Receptacle Firewall MS27614K, Pyle FPK Threaded MS27614K, Pyle FYL, Bayonet . . . . . 221
- Straight Plug, Firewall MS27615K, Pyle FPK Threaded MS27615K, Pyle FYL, Bayonet Ratchet Lock Plug, Firewall MS27615K, Pyle FPK Threaded . . . . . 222

### MIL-DTL-26500, 48 Series Interconnect Products:

- Receptacle Short Shirt & Wire Splice Connector . . . . . 223, 224

### MIL-DTL-26500 Hermetic Receptacle Shell Styles:

- Pyle ZZL/ZZB Hermetic Receptacles (three styles) Threaded or Bayonet . . . . . 225

### Contacts & Accessories

- Shielded Coaxial Contacts, Contact Terminating Tools, Assembly Instructions, Cable Supports, Dummy Receptacles, Protection Caps . . . . . 226-235



## MIL-DTL-26500, Pyle® Typical Markets:

- Military & Commercial Aviation
- High Temperature Applications
- Meets Boeing Specifications
- Missiles & Ordnance



**High quality and dependability are the earned reputations of the Amphenol®/Pyle Series of connectors designed to meet the specification requirements of MIL-DTL-26500. Serving such diverse fields as avionics, missile systems, aircraft general-purpose applications, aircraft engines and firewalls, the Amphenol/Pyle MIL-DTL-26500 connector family meets the myriad of problems with innovative connector solutions.**

High quality and dependability are the earned reputations of the Amphenol/Pyle Series of connectors designed to meet the specification requirements of MIL-DTL-26500. Serving such diverse fields as avionics, missile systems, aircraft general-purpose applications, aircraft engines and firewalls, the Amphenol/Pyle MIL-DTL-26500 connector family meets the myriad of problems with innovative connector solutions.

Amphenol /Pyle MIL-DTL-26500 Connectors are medium sized connectors with a rugged design, lightweight construction and continuously dependable performance. This product family provides the following design features and options:

### Aluminum Connectors - Military Classes R and G; Proprietary (ZZY, ZZW)

- General purpose, environmentally resistant
- Threaded or bayonet coupling
- Square flange or single hole receptacles, and straight plug shell styles
- Black anodize non-conductive finish for class R and a conductive finish in class G that provides a minimum resistance path through the shell for grounding purposes
- Coupling nuts are hard coat treated for added protection against wear
- Rear accessory threads accommodate standard MS27291 series cable supports or related accessory hardware

### Stainless Steel Connectors - Military Class E; Proprietary (ZZY, ZZW)

- Machined from 300-series stainless steel providing superior strength and wear characteristics
- Threaded or bayonet coupling
- Shells experience a less than 10% loss in yield strength at elevated temperatures, 204°C (399°F)
- Shell hardware resists corrosion for the life of the connector without the need of additional finishes
- Same shell styles offered as in aluminum
- Variety of stainless steel accessories are available

### Firewall Connectors – Military Class K; Proprietary (FPK, FYL)

- Meets the fireproof requirements of MIL-DTL-5015, Class K
- Threaded or bayonet coupling
- FPL - threaded coupling; same as FPK; used on Lockheed Aircraft
- FP5K - threaded coupling; same as FPK; qualified for General Electric
- Non-magnetic stainless steel shells designed for superior strength and elevated temperatures up to 460°F for extended periods
- Same shell styles as stainless steel and aluminum versions

### 48 Series Receptacle Short Skirt - Amphenol special application connector,

- Low profile design for restricted installation requirements
- Wire Splice Connector
- Space saving, single contact, wire splice module

### Hermetic Connectors - Military Class H; Proprietary (ZZL, ZZB)

- See page 225 for brief description
- See page 225 for hermetic insert availability
- Consult Amphenol, Sidney, NY for availability and ordering information.

### Contacts and Accessories for MIL-DTL-26500 connectors

- SAE AS39029 qualified contacts and special application contacts including thermocouple, printed circuit board and shielded/coaxial types
- Boeing specification contacts
- Aluminum and stainless steel cable supports; aluminum dummy receptacles
- Contact crimping/ installation/removal tools for Amphenol 48 series and Pyle-National MIL-DTL-26500 series

38999  
SJT I II III

26482  
Matrix 2

83723 III  
Matrix Pyle

5015  
Crimp Rear  
Release Matrix

26500 Pyle

Printed  
Circuit Board

EMI Filter  
Transient

Fiber Optics

High Speed  
Contacts

Options  
Others



# MIL-DTL-26500, Pyle® Connectors

## Features and Class Descriptions



Amphenol®/Pyle MIL-DTL-26500 Connectors are qualified to Military Specification MIL-DTL-26500, as well as numerous high performance customer specifications. These connectors are available in aluminum or stainless steel shells, with bayonet or threaded coupling, and are qualified to meet the specifications of the following MIL-DTL-26500 classes:

| MIL-DTL-26500 Classes              | Amphenol/Pyle Series Classes | Hardware Description | Finish     |
|------------------------------------|------------------------------|----------------------|------------|
| Class R: (Environmental Resistant) | A                            | Aluminum Alloy       | Anodize    |
| Class G                            | M                            | Aluminum Alloy       | Chromium   |
| Class E                            | R                            | Stainless Steel      | Passivated |
| Class K Firewall                   | FPK/FYL                      | Stainless Steel      | Passivated |
| Class H Hermetic                   | HC                           | CRS/Stainless Steel  | Various    |

### Crimp Contacts

Rear-insertable, front-releasable, crimp style contacts are machined from a copper alloy material, plated gold over nickel, and are qualified to specification SAE AS39029.

Contacts are crimp terminated outside the connector assembly and inserted into the appropriate cavity by means of a hand tool. Socket contacts utilize a multi-tined construction and feature a “C” spring which grips the tines, and insures consistent and repetitive insertion/withdrawal forces. Contact tines are protected by a stainless steel shroud.

An optional pencil-clip thermocouple socket design is also offered. See page 226 for more information on thermocouple contacts.

### Alternate Keying

All MIL-DTL-26500 Series Connector shells can be furnished with normal or any of five alternate key positions. (See page 204). Each plug shell has a master key and four alternate keys. The position of the alternate keys in relation to the fixed master key determines the key identification. Inserts are bonded to the shell in relation to the master key, thus allowing positive protection against mis-mating when differing circuits exist side by side.

### Connector Sealing

The insert design utilizes a combination of resilient and rigid insulators to offer a connector with total sealing capabilities. Bonded interfaces between the resilient and rigid dielectric components eliminate air voids and thus protect the connector from potential degradation due to moisture and altitude conditions.

In Firewall Class K connectors, the resilient insert forms the primary contact seal and is bonded to a molded ceramic rigid insert. The insert assembly is physically bonded and mechanically retained to the inside surface of the stainless steel shell, providing a void-less, mono-block configuration impervious to adverse environments.

A pressure seal at the connector interface is accomplished through the aid of a coupling device which compresses the front resilient insulations and thus offers a seal around each contact which prevents the passage of air or moisture through the contact cavity.

Back resilient insulators are designed with a triple sealing grip at each wire hole to offer positive sealing and prevent wicking of moisture through the connector without the use of external clamping rings or adapters.



In addition, a dynamic “O” ring seal engages the front of the plug shell when connectors are mated and offers yet another barrier to moisture and containments.

### Fluid/Temperature Resistance

The fluorosilicone compound elastomer, developed by Pyle-National, exceeds all specification requirements and provides excellent resistance to tear, compression set, fluids, and high temperatures.

Amphenol/Pyle’s fluorosilicone compound offered in Class R, G, E and K is capable of reliability resisting:

- MIL-H-5606 hydraulic fluid
- MIL-L-9236 lubricating oil
- MIL-L-7808 and MIL-L-23699 lubricating oils
- MIL-J-5624 (JP-5) jet fuel
- Glycol
- Alkaline cleaning solutions of pH 10 or higher.

Test methods are as defined in MIL-DTL-26500 specification. Alternate compounds have been developed by Pyle-National to solve unique user requirements not addressed by the specifications.

Connectors have the capability of resisting high ambient temperatures up to 200°C (392°F) for long periods of time, thus contributing to an extended connector life. Connectors will withstand a combined ambient and internal temperature due to thermal rise of current carrying capacity of 238°C (469°F).

Amphenol®/Pyle® Firewall, Class K, connectors have the inherent ability to resist high temperatures up to 460°F (total temperature) for extended periods of time and can resist short time exposures (20 minutes) to prevent passage of a direct 2000°F flame.

III  
II  
I  
SJT  
38999

Matrix 2  
26482

Matrix  
Pyle  
83723 III

Crimp Rear  
Release Matrix  
5015

26500 Pyle

Printed  
Circuit Board

EMI Filter  
Transient

Fiber Optics

High Speed  
Contacts

Options  
Others

38999  
SJT I II III

26482  
Matrix 2

83723 III  
Matrix Pyle

5015  
Crimp Rear Release Matrix

26500 Pyle

Printed  
Circuit Board

EMI Filter  
Transient

Fiber Optics

High Speed  
Contacts

Options  
Others

| TEST REQUIREMENTS                             | MILITARY SPECIFICATIONS  | PYLE CONNECTOR CAPABILITIES  |
|---|--|--|
| Air Leakage (Classes E, G, R & K)             | 1 cu. inch per hr. max. -55°C (-67°F)  | Comply   |
| Altitude Immersion (Classes E, G, R & K)      | Sea level 1 inch of mercury, 3 cycles (IR 5000 megohms hi-pot 1500 volts-submerged)  | Comply   |
| Contact Retention (Classes E, G, R & K)       | Size 20 contact 20 lbs. min.<br>Size 16 contact 25 lbs. min.<br>Size 12 contact 30 lbs. min.   | Exceeds specifications   |
| Collet Retention                              | No requirement   | Without damage to the collet or its retention means:<br>Size 20 – 75 lbs. min.<br>Size 16 – 140 lbs. min.<br>Size 12 – 160 lbs. min. |
| Contact Insertion Force (Classes E, G, R & K) | All size contacts 10 lbs. max.   | Comply   |
| Coupling Forces                               | Torque required to couple and uncouple mating plugs and receptacles is not to exceed the values listed:<br>Shell size Torque inch lbs.<br>8 10 12 14 16 18 20 22 24<br>9 10 14 17 23 26 31 38 46 | Comply   |
| Fluid Resistance (Classes E, G, R & K)        | 20 hrs. immersion in MIL-H-5606 hydraulic fluid and MIL-L-9236 lubrication oil. Must meet hi-pot.  | 20 hrs. min., fully functional physically and electrically after immersion. No deterioration of resilient material.                  |
| Ground Resistance (Class G)                   | .250 ohms backshell of plug to rear of receptacle flange.  | Comply   |
| High Potential (Classes E, G, R & K)          | 1500 VRMS mated & unmated at sea level<br>1000 VRMS mated to 110,000 ft. altitude  | Exceed with ample margin of safety.  |
| Insert Retention (Classes E, G, R & K)        | 75 psi. from either direction for 5 seconds.   | Exceeds specifications.  |
| Insulation Resistance (Classes E, G, R & K)   | 21°C (70°F), 5000 megohms between adjacent contacts and any contact and shell.   | Exceeds specifications.  |
| Low Temperature (Classes E, G, R & K)         | -55°C (-67°F)  | Comply   |
| Magnetic Permeability (Classes E, G, R & K)   | 2 mu. maximum  | Comply   |
| Moisture Resistance (Classes E, G, R & K)     | 1000 megohms min. per Mil-std. 202 method 106  | Comply   |
| Ozone Exposure (Classes E, G, R & K)          | 0.10 to .015% ozone exposure   | Comply   |
| Physical Shock (Classes E, G, R & K)          | 50 G's, 3 axis, per mil-std-202, method 213, test condition C, wired to monitor 1 microsecond discontinuity.   | Comply   |
| Sand & Dust Exposure (Classes E, G, R & K)    | No requirement.  | Meet MIL-E-5272 condition "B"  |
| Temperature Life (Classes E, G, R & K)        | Connector fully functional for 1000 hours at 200°C (392°F) ambient internal temperature 238°C (460°F)  | Comply   |
| Thermal Shock (Mated) (Classes E, G, R & K)   | Cycled five times from -55°C to 260°C, held for 30 minutes at each temperature and transferred to the other in 2 minutes or less, with no evidence of damage.                                    | Comply   |
| Vibration (Classes E, G, R & K)               | MIL-Std. 202 method 204 condition "D" at R. T., -55°C (-67°F) and +200°C (+392°F).   | Comply - monitored for a max. of 1 microsecond discontinuity.  |
| Flame Resistance (Class K)                    | Performance requirements of Paragraph 4.5.18 Fireproof (Class K of MIL-DTL-5015D)  | Exceeds specifications   |

# MIL-DTL-26500, Pyle®

## Insert Arrangements



### Front Face of Pin Insert or Rear Face of Socket Insert Illustrated

Contact cavities are identified with a spiral guide line indicating cavity sequence. The first and last cavities are numbered and every tenth cavity is bracketed. Symmetrical about center line.



| Insert Arrangement | 08-02 | 08-03 <sup>H</sup> | 10-02** | 10-05 <sup>H</sup> | 10-20 <sup>H</sup> | 12-03 <sup>KH</sup> | 12-12 <sup>H</sup> | 14-03            | 14-04 <sup>K</sup> |
|--------------------|-------|--------------------|---------|--------------------|--------------------|---------------------|--------------------|------------------|--------------------|
| Service Rating     | I     | I                  | I       | I                  | I                  | I                   | I                  | I                | I                  |
| Number of Contacts | 2     | 3                  | 2       | 5                  | 2                  | 3                   | 12                 | 2                | 4                  |
| Contact Size       | 20    | 20                 | 20      | 20                 | 16                 | 16                  | 20                 | 16               | 12                 |
|                    |       |                    |         |                    |                    |                     |                    | 12               | 12                 |
|                    |       |                    |         |                    |                    |                     |                    | Shielded Coaxial |                    |



| Insert Arrangement | 14-07 <sup>KH</sup> | 14-12 | 14-15 <sup>KH</sup> | 16-10 <sup>KH</sup> | 16-24 <sup>KH</sup> | 18-08 <sup>KH</sup> | 18-11 | 18-14 <sup>KH</sup> |
|--------------------|---------------------|-------|---------------------|---------------------|---------------------|---------------------|-------|---------------------|
| Service Rating     | I                   | I     | I                   | I                   | I                   | I                   | 1     | I                   |
| Number of Contacts | 7                   | 9     | 3                   | 15                  | 10                  | 24                  | 8     | 10                  |
| Contact Size       | 16                  | 20    | 16                  | 20                  | 16                  | 20                  | 12    | 16                  |
|                    |                     |       |                     |                     |                     |                     |       | 12                  |
|                    |                     |       |                     |                     |                     |                     |       | Shielded Coaxial    |



| Insert Arrangement | 18-31 <sup>KH</sup> | 20-16 | 20-25 | 20-28** | 20-39 | 20-41 |
|--------------------|---------------------|-------|-------|---------|-------|-------|
| Service Rating     | I                   | I     | I     | I       | I     | I     |
| Number of Contacts | 31                  | 16    | 19    | 6       | 24    | 4     |
| Contact Size       | 20                  | 16    | 20    | 12      | 20    | 12    |
|                    |                     |       |       |         | 37    | 2     |
|                    |                     |       |       |         | 20    | 16    |
|                    |                     |       |       |         |       | 41    |
|                    |                     |       |       |         |       | 20    |

† designates Non-MS Configurations.  
 K designates Firewall Class K inserts.  
 H designates Hermetic inserts.

CONTACT LEGEND



38999  
III  
II  
I  
SJT

26482  
Matrix 2

83723 III  
Matrix  
Pyle

5015  
Crimp Rear  
Release Matrix

26500 Pyle

Printed  
Circuit Board

EMI Filter  
Transient

Fiber Optics

High Speed  
Contacts

Options  
Others

### Front Face of Pin Insert or Rear Face of Socket Insert Illustrated

Contact cavities are identified with a spiral guide line indicating cavity sequence. The first and last cavities are numbered and every tenth cavity is bracketed. Symmetrical about centerline.

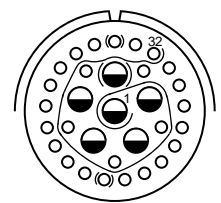
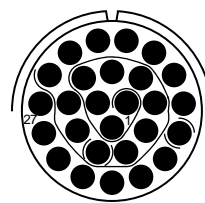
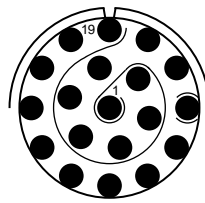
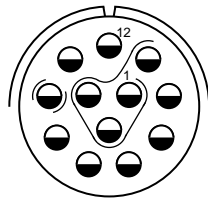

| Insert Arrangement | 22-12 <sup>K</sup> | 22-19 <sup>KH</sup> | 22-27 <sup>†</sup> | 22-32 |
|--------------------|--------------------|---------------------|--------------------|-------|
| Service Rating     | I                  | I                   | I                  | I     |
| Number of Contacts | 12                 | 19                  | 27                 | 26 6  |
| Contact Size       | 12                 | 16                  | 16                 | 20 12 |

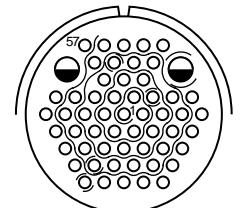
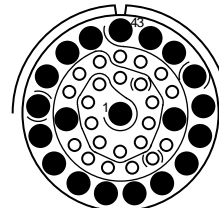
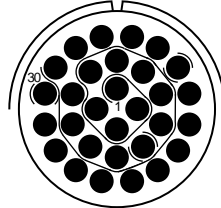
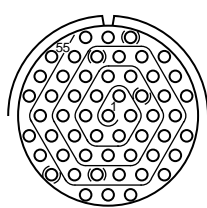

| Insert Arrangement | 22-55 <sup>KH</sup> | 24-30 <sup>†K</sup> | 24-43 <sup>**</sup> | 24-57 |
|--------------------|---------------------|---------------------|---------------------|-------|
| Service Rating     | I                   | I                   | I                   | I     |
| Number of Contacts | 55                  | 30                  | 23 20               | 55 2  |
| Contact Size       | 20                  | 16                  | 20 16               | 20 12 |

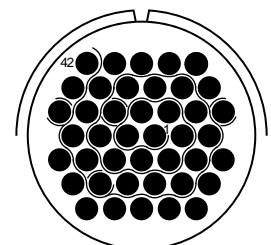
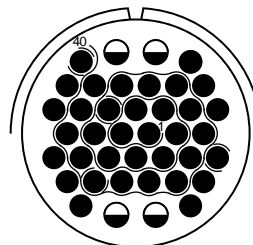
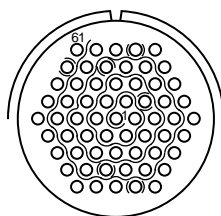

| Insert Arrangement | 24-61 | 28-40 <sup>†K</sup> | 28-42 <sup>†K</sup> |
|--------------------|-------|---------------------|---------------------|
| Service Rating     | I     | I                   | I                   |
| Number of Contacts | 61    | 36 4                | 42                  |
| Contact Size       | 20    | 16 12               | 16                  |

† designates Non-MS Configurations.  
K designates Firewall Class K inserts.  
H designates Hermetic inserts.



### Alternate Keying Positions of Shells

ALTERNATE POLARITY KEYWAY ARRANGEMENTS (Shell sizes 12, 14, 16, 18, 20, 22, 24, 28) View of front face of receptacle shell. Angles are counter-clockwise from "N" keyway. For plug shell, the key locations are clockwise when viewed from front of plug.

| Position | For Connectors Size 8 and 10 |      |      |      | For Connectors Size 12, 14, 16, 18, 20, 22, 24 and 28 |      |      |      |
|----------|------------------------------|------|------|------|---|------|------|------|
|          | A                            | B    | C    | D    | A   | B    | C    | D    |
| Normal   | 105°                         | 140° | 215° | 265° | 105°  | 140° | 215° | 265° |
| 6        | 102°                         | 132° | 248° | 320° | 18°   | 149° | 192° | 259° |
| 7        | 80°                          | 118° | 230° | 312° | 92°   | 152° | 222° | 342° |
| 8        | 35°                          | 140° | 205° | 275° | 84°   | 152° | 204° | 334° |
| 9        | 64°                          | 155° | 234° | 304° | 24°   | 135° | 199° | 240° |
| Y or 10* | 25°                          | 115° | 220° | 270° | 98°   | 152° | 268° | 338° |

\* Y is used for all Military part number call-outs - aluminum/stainless steel and firewall; 10 is used for Amphenol/Pyle part number call-outs - aluminum/stainless steel only. (See how to order pages 207, 208 and 218).

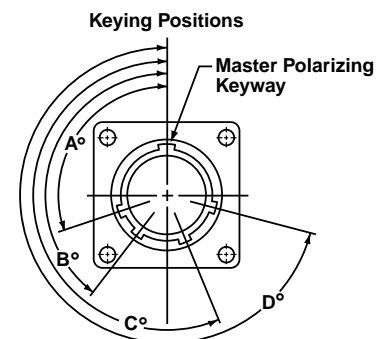



Shown is Engaging Face View of Receptacle Shell with Keyways (Plug Shell Keys would be Opposite)

### THREADED COUPLING

#### PYLE ZZY



#### MS2426X( )TXX

| Shell Style<br>(Stainless Steel pictured)  | Basic Performance Level                                     | Hardware Description* | Class*                | Basic Part Number**  |
|--|---|-----------------------|-----------------------|----------------------|
| <br>Square Flange Mounted Receptacle Threaded Coupling        | General Purpose, Environmental Resistant                    | Aluminum              | Military Class R or G | MS24264(R or G)XXTXX |
|  |   |                       | Pyle A or M Series    | ZZY-(A or M)X-17XX   |
|  | Superior Strength, Corrosion Resistance up to 204°C (399°F) | Stainless Steel       | Military Class E      | MS24264EXXTXX        |
|  |   |                       | Pyle R Series         | ZZY-RX-17XX          |
| <br>Single Hole (D-Hole) Mounted Receptacle Threaded Coupling | General Purpose, Environmental Resistant                    | Aluminum              | Military Class R or G | MS24265(R or G)XXTXX |
|  |   |                       | Pyle A or M Series    | ZZY-(A or M)X-15XX   |
|  | Superior Strength, Corrosion Resistance up to 204°C (399°F) | Stainless Steel       | Military Class E      | MS24265EXXTXX        |
|  |   |                       | Pyle R Series         | ZZY-RX-15XX          |
| <br>Straight Plug Threaded Coupling                           | General Purpose, Environmental Resistant                    | Aluminum              | Military Class R or G | MS24266(R or G)XXTXX |
|  |   |                       | Pyle A or M Series    | ZZY-(A or M)X-10XX   |
|  | Superior Strength, Corrosion Resistance up to 204°C (399°F) | Stainless Steel       | Military Class E      | MS24266EXXTXX        |
|  |   |                       | Pyle R Series         | ZZY-RX-10XX          |

### BAYONET COUPLING

#### PYLE ZZW

#### MS2426X( )BXX

| Shell Style<br>(Stainless Steel pictured)   | Basic Performance Level                                     | Hardware Description* | Class*                | Basic Part Number**  |
|---|---|-----------------------|-----------------------|----------------------|
| <br>Square Flange Mounted Receptacle Bayonet Coupling        | General Purpose, Environmental Resistant                    | Aluminum              | Military Class R or G | MS24264(R or G)XXBXX |
|   |   |                       | Pyle A or M Series    | ZZW-(A or M)X-17XX   |
|   | Superior Strength, Corrosion Resistance up to 204°C (399°F) | Stainless Steel       | Military Class E      | MS24264EXXTXX        |
|   |   |                       | Pyle R Series         | ZZW-RX-17XX          |
| <br>Single Hole (D-Hole) Mounted Receptacle Bayonet Coupling | General Purpose, Environmental Resistant                    | Aluminum              | Military Class R or G | MS24265(R or G)XXBXX |
|   |   |                       | Pyle A or M Series    | ZZW-(A or M)X-15XX   |
|   | Superior Strength, Corrosion Resistance up to 204°C (399°F) | Stainless Steel       | Military Class E      | MS24265EXXTXX        |
|   |   |                       | Pyle R Series         | ZZW-RX-15XX          |
| <br>Straight Plug Bayonet Coupling                           | General Purpose, Environmental Resistant                    | Aluminum              | Military Class R or G | MS24266(R or G)XXBXX |
|   |   |                       | Pyle A or M Series    | ZZW-(A or M)X-10XX   |
|   | Superior Strength, Corrosion Resistance up to 204°C (399°F) | Stainless Steel       | Military Class E      | MS24266EXXTXX        |
|   |   |                       | Pyle R Series         | ZZW-RX-10XX          |

NA designates not available

\* See how to order, page 207, for further description of hardware classes.

\*\* See how to order, page 207, to complete part numbers.

38999  
III  
II  
I  
SJT

26482  
Matrix 2

83723 III  
Matrix  
Pyle

5015  
Crimp Rear  
Release Matrix

26500 Pyle

Printed  
Circuit Board

EMI Filter  
Transient

Fiber Optics

High Speed  
Contacts

Options  
Others



38999  
SJT I II III

**RATCHET LOCK PLUG, BAYONET  
PYLE ZZY**

26482  
Matrix 2

83723 III  
Matrix Pyle

5015  
Crimp Rear  
Release Matrix

| Shell Style<br>(Stainless steel only)   | Basic<br>Performance Level  | Hardware<br>Description* | Class*                             | Basic Part Number** |
|---|---|--------------------------|------------------------------------|---------------------|
|  <p>Ratchet Lock Plug<br/>Non-Decoupling</p> | Superior Strength, Corrosion Resistance up to 204°C (399°F)<br>Employs ratchet feature in last 120° of rotation to eliminate need for safety-wiring | Stainless Steel only     | Pyle R Series<br>(Commercial only) | ZZY-RX-12XX         |
| <p>NNDC<br/>Plug<br/>New Non-Decoupling</p>   | Superior Strength, Corrosion Resistance up to 204°C (399°F)   | Stainless Steel only     | Pyle R Series<br>(Commercial only) | ZZY-RX-13XX         |

\* See how to order, page 207, for further description of hardware classes.  
\*\* See how to order, page 207, to complete part numbers.

26500 Pyle

Printed  
Circuit Board

**RATCHET LOCK PLUG & MATING FLANGE MOUNTED, THREADED RECEPTACLE  
PYLE ZZY**

EMI Filter  
Transient

Fiber Optics

High Speed  
Contacts

Options  
Others

| Shell Style<br>(Stainless steel pictured)   | Basic<br>Performance Level   | Hardware<br>Description* | Class*        | Pyle Basic Part Number**                |
|---|--|--------------------------|---------------|---|
|  <p>Ratchet Lock Plug<br/>Non-Decoupling</p>                   | Designed to meet high vibration requirements beyond MIL-DTL-26500. | Aluminum                 | Pyle A Series | ZZY (A, D, F, M)<br>X-12 (D, E or F) XX |
|   |  | Stainless Steel          | Pyle R Series | ZZY-RX-12 (D, E or F)XX                 |
|  <p>Square Flange Mounted Receptacle<br/>Threaded Coupling</p> | Designed to meet high vibration requirements beyond MIL-DTL-26500. | Aluminum                 | Pyle A Series | ZZY (A or F) X-17(D, E or F) XX         |
|   |  | Stainless Steel          | Pyle R Series | ZZY-RX-17 (D, E or F) XX                |

\* See how to order, page 208, for further description of hardware classes.  
\*\* See how to order, page 208, to complete part numbers.



### Easy Steps to build a part number... Military

| 1. Shell Style | 2. Service Class | 3. Shell Size | 4. Coupling Type | 5. Insert Arrangement | 6. Contact Type | 7. Alternate Keying |
|----------------|------------------|---------------|------------------|-----------------------|-----------------|---------------------|
| MS24266        | R                | 22            | T                | 55                    | P               | 6                   |

#### Step 1. Select a Shell Style

|         | Designates                       |
|---------|----------------------------------|
| MS24264 | Square Flange Mounted Receptacle |
| MS24265 | Single D-Hole Mounted Receptacle |
| MS24266 | Straight Plug                    |

#### Step 5. Select an Insert Arrangement from page 203 & 204

See page 203 & 204 for Shell Size & Insert Arrangements. First number represents Shell Size, second number is the Insert Arrangement.

#### Step 2. Select a Service Class

|   | Designates                                      |
|---|---|
| R | Aluminum, non-conductive (black anodize finish) |
| G | Aluminum, conductive (chromium finish)          |
| E | Stainless steel, Passivated                     |

#### Step 6. Select a Contact Type

|   | Designates      |
|---|-----------------|
| P | Pin Contacts    |
| S | Socket Contacts |

#### Step 3. Select a Shell Size

|   |    |    |    |    |    |    |    |    |
|---|----|----|----|----|----|----|----|----|
| 8 | 10 | 12 | 14 | 16 | 18 | 20 | 22 | 24 |
|---|----|----|----|----|----|----|----|----|

#### Step 7. Select an Alternate Keying Position of Shell

6, 7, 8, 9, Y (N for Normal) See page 204.

#### Step 4. Select a Coupling Type

|   | Designates |
|---|------------|
| T | Threaded   |
| B | Bayonet    |

|                           |           |
|---------------------------|-----------|
| III                       | 38999     |
| II                        |           |
| I                         |           |
| SJT                       |           |
| Matrix 2                  | 26482     |
| Matrix                    | 83723 III |
| Pyle                      |           |
| Crimp Rear Release Matrix | 5015      |

|                       |            |
|-----------------------|------------|
| Printed Circuit Board | 26500 Pyle |
| EMI Filter Transient  |            |
| Fiber Optics          |            |
| High Speed Contacts   |            |
| Options Others        |            |

### Easy Steps to build a part number... Pyle Commercial

| 1. Shell Style | 2. Service Class | 3. Contacts/Accessories | 4. Shell Style | 5. Shell Size | 6. Insert Arrangement | 7. Contact Type | 8. Alternate Keying | 9. Contact Plating | 10. Deviations/Specials |
|----------------|------------------|-------------------------|----------------|---------------|-----------------------|-----------------|---------------------|--------------------|-------------------------|
| ZZY            | A                | C                       | 10             | 22            | 55                    | P               | 6                   | D                  | XXX                     |

#### Step 1. Select a Shell Style

|     | Designates        |
|-----|-------------------|
| ZZY | Threaded Coupling |
| ZZW | Bayonet Coupling  |

#### Step 4. Select a Shell Style

|    | Designates                               |
|----|--|
| 10 | Straight Plug                            |
| 12 | Non-Decoupling Plug(Ratchet Lock)        |
| 13 | New Non-Decoupling Plug (NNDC) (SS only) |
| 15 | Single Hole Mounting Receptacle          |
| 17 | Square Flange Receptacle                 |

#### Step 8. Select an Alternate Keying Position of Shell

06, 07, 08, 09, 10 (Omit for Normal) See page 204.

#### Step 2. Select a Service Class

|   | Designates                                      |
|---|---|
| A | Aluminum, non-conductive (black anodize finish) |
| D | Aluminum, O.D. CAD/Ni                           |
| F | Aluminum, Clear Cadmium plated                  |
| M | Aluminum, conductive (chromium finish)          |
| R | Stainless steel, Passivated                     |

#### Step 5. Select a Shell Size

|   |    |    |    |    |    |    |    |    |    |
|---|----|----|----|----|----|----|----|----|----|
| 8 | 10 | 12 | 14 | 16 | 18 | 20 | 22 | 24 | 28 |
|---|----|----|----|----|----|----|----|----|----|

#### Step 9. Select a Contact Plating

|   | Designates |
|---|------------|
| D | Gold       |
| T | Rhodium    |

#### Step 3. Select Contacts & Accessories

|          | Designates                           |
|----------|--------------------------------------|
| No Digit | with contacts and cable support      |
| C        | without cable support, with contacts |
| D        | without contacts, with cable support |
| O        | without contacts or cable support    |

#### Step 6. Select an Insert Arrangement from page 203 & 204

See page 203 & 204 Shell Size & Insert Arrangements. First number represents Shell Size, second number is the Insert Arrangement.

#### Step 7. Select a Contact Type

|   | Designates      |
|---|-----------------|
| P | Pin Contacts    |
| S | Socket Contacts |

#### Step 10. Deviation/Specials

Consult Amphenol for more information.

Accessory threads for aluminum and stainless steel hardware differ, and care should be taken in selection of alternate accessory hardware that will conform to the threads noted in the dimensional tables within this catalog.

Amphenol®/Pyle® connectors are specifically designed to meet high vibration requirements above and beyond the specification requirements of MIL-DTL-26500. The plug connector features a unique non-decoupling device which offers a ratchet mechanism designed to engage as the threaded connectors approach a bottomed condition. Connector coupling assembly continues to ratchet for approximately 120 degrees until the mated connectors reach a complete metal-to-metal bottomed condition. The ratchet device maintains the connectors in a fully coupled condition, thus eliminating the need for safety wiring.



### Additional features include:

- Modified accessory thread to accommodate MIL-DTL-83723 backshell hardware.
- Rear accessory teeth are featured on both the plug and receptacle shell to assure non-rotation of accessory hardware
- Intermateable with all MIL-DTL-26500 threaded connectors of like insert arrangement and key position

## Easy Steps to build a part number... Pyle Commercial

| 1. Shell Style | 2. Service Class | 3. Contacts & Accessories | 4. Shell Style | 5. Accessory Style | 6. Insert Arrangement | 7. Contact Type | 8. Alternate Keying | 9. Contact Plating | 10. Deviations/Specials |
|----------------|------------------|---------------------------|----------------|--------------------|-----------------------|-----------------|---------------------|--------------------|-------------------------|
| ZZY            | A                | C                         | 12             | D                  | 14                    | 04              | P                   | 06                 | D                       |

### Step 1. Select a Shell Style

|     | Designates        |
|-----|-------------------|
| ZZY | Threaded Coupling |

### Step 2. Select a Service Class

|   | Designates                                      |
|---|---|
| A | Aluminum, non-conductive (black anodize finish) |
| D | Aluminum, O.D. CAD/Ni                           |
| F | Aluminum, Clear Cadmium plated                  |
| M | Aluminum, conductive (chromium finish)          |
| R | Stainless steel, Passivated                     |

### Step 3. Select Contact & Accessory

|          | Designates              |
|----------|-------------------------|
| No Digit | With contacts and clamp |
| C        | With contacts           |
| O        | Without contacts        |

### Step 4. Select a Shell Style

|    | Designates                               |
|----|--|
| 12 | Non-Decoupling Plug, (Ratchet Lock)      |
| 13 | New Non-Decoupling Plug (NNDC) (SS only) |
| 17 | Square Flange Mounted Receptacle         |

### Step 5. Select Accessory Style

|   | Designates   |
|---|--|
| D | Rear accessories per MIL-DTL-83723, 3 Accessory Serrations.            |
| E | Rear accessories per MS 3155 (360° Accessory Serrations)               |
| F | Rear accessories per MS 3155 with EMI Band (360° Accessory Serrations) |

Accessory threads for aluminum and stainless steel hardware differ, and care should be taken in selection of alternate accessory hardware that will conform to the threads noted in the dimensional tables within this catalog.

### Step 5. Select a Shell Size

|    |    |    |    |    |    |    |    |    |
|----|----|----|----|----|----|----|----|----|
| 10 | 12 | 14 | 16 | 18 | 20 | 22 | 24 | 28 |
|----|----|----|----|----|----|----|----|----|

### Step 6. Select an Insert Arrangement from Page 203 & 204

Shell Size & Insert Arrangements are on pages 203 & 204. First number represents Shell Size, second number is the Insert Arrangement.

### Step 7. Select a Contact Type

|   | Designates      |
|---|-----------------|
| P | Pin Contacts    |
| S | Socket Contacts |

### Step 8. Select an Alternate Keying Position of Shell

06, 07, 08, 09, 10 (Omit for Normal) See page 204

### Step 9. Select a Contact Plating

|   | Designates                      |
|---|---------------------------------|
| D | Gold plate per MIL-DTL-39029    |
| T | Rhodium plate per MIL-DTL-26636 |

### Step 10. Deviations/Specials

Consult Amphenol for more information.

38999

SJT

I

II

III

26482

Matrix 2

83723 III

Matrix

Pyle

5015

Crimp Rear Release Matrix

26500 Pyle

Printed Circuit Board

EMI Filter Transient

Fiber Optics

High Speed Contacts

Options Others

# MS24264, Pyle® ZZY, MIL-DTL-26500

## Square Flange Mounted Receptacle, Threaded



### Part #

To complete see how to order pages 207

### Military

| Shell Style | Service Class | Shell Size | Coupling Type | Insert Arrangement | Contact Type | Alternate Keying |
|-------------|---------------|------------|---------------|--------------------|--------------|------------------|
| MS24264     | E, R, G       | XX         | T             | XX                 | X            | X                |

### Commercial

| Shell Style | Service Class | Contacts & Accessories | Shell Style | Shell Size | Insert Arrangement | Contact Type | Alternate Keying | Contact Plating | Deviations/ Specials |
|-------------|---------------|------------------------|-------------|------------|--------------------|--------------|------------------|-----------------|----------------------|
| ZZY         | X             | X                      | 17          | XX         | XX                 | X            | X                | X               | XXX                  |

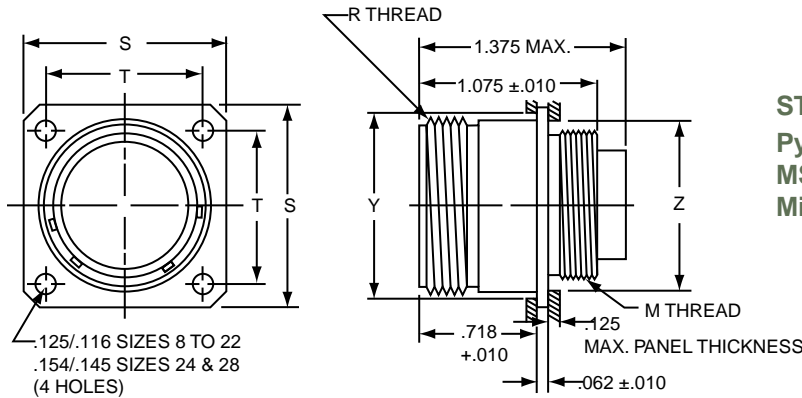

**STAINLESS STEEL**  
Pyle ZZY-RX-17XX Series  
MS24264EXXTXX  
Military Class E

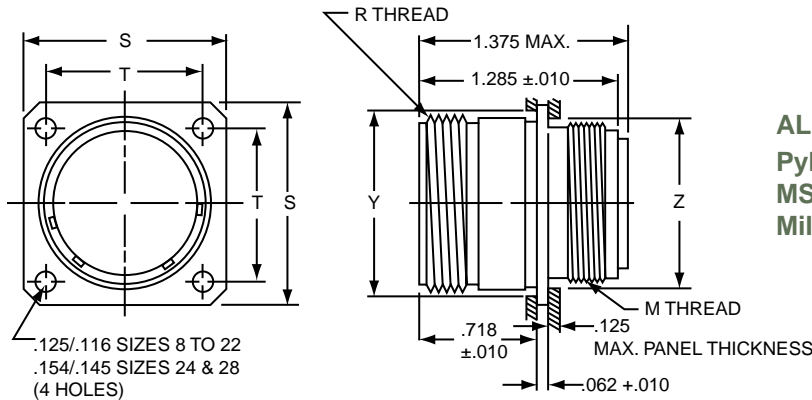

**ALUMINUM**  
Pyle ZZY-XX-17XX Series  
MS24264RXXTXX  
Military Class R and G

| Shell Size | M Cable Support Thread |                        | Aluminum Connector Weight (lbs.) max including Contacts |               | R Coupling Thread | S Flange Width ±.005 | T Mounting Hole Centers ±.005 | Y Back Mount Min. Hole | Z Front Mount Min. Hole |
|------------|------------------------|------------------------|---|---------------|-------------------|----------------------|-------------------------------|------------------------|-------------------------|
|            | Steel NS-2A            | Alum. UNEF-2A Modified | Pin Insert  | Socket Insert |                   |                      |                               |                        |                         |
| 08**       | NA                     | .437-28                | .025  | .026          | .562-24           | .812                 | .594                          | .606                   | .443                    |
| 10         | .563-36                | .562-24                | .042  | .044          | .687-24           | .937                 | .719                          | .748                   | .572                    |
| 12         | .733-36                | .750-20                | .061  | .062          | .875-20           | 1.031                | .812                          | .913                   | .760                    |
| 14         | .803-36                | .812-20                | .072  | .074          | .937-20           | 1.125                | .906                          | .980                   | .822                    |
| 16         | .930-36                | .937-20                | .087  | .090          | 1.062-18          | 1.250                | .969                          | 1.107                  | .948                    |
| 18         | 1.036-36               | 1.062-18               | .110  | .112          | 1.187-18          | 1.343                | 1.062                         | 1.209                  | 1.072                   |
| 20         | 1.161-36               | 1.187-18               | .130  | .134          | 1.312-18          | 1.437                | 1.156                         | 1.325                  | 1.197                   |
| 22         | 1.286-36               | 1.312-18               | .152  | .159          | 1.437-18          | 1.562                | 1.250                         | 1.452                  | 1.322                   |
| 24         | 1.411-36               | 1.437-18               | .181  | .188          | 1.562-18          | 1.703                | 1.375                         | 1.577                  | 1.448                   |
| 28†        | 1.661-36               | NA                     | NA  | NA            | 1.812-16          | 2.000                | 1.562                         | 1.827                  | 1.700                   |

NA designates not available. \*\* Not available in Stainless Steel. † Not available in Aluminum.  
All dimensions for reference only.

III  
II  
I  
SJT  
38999

26482  
Matrix 2

83723 III  
Matrix  
Pyle

5015  
Crimp Rear  
Release Matrix

26500 Pyle

Printed  
Circuit Board

EMI Filter  
Transient

Fiber Optics

High Speed  
Contacts

Options  
Others

### Part #

To complete see how to order pages 207

### Military

| Shell Style | Service Class | Shell Size | Coupling Type | Insert Arrangement | Contact Type | Alternate Keying |
|-------------|---------------|------------|---------------|--------------------|--------------|------------------|
| MS24265     | E or R        | XX         | T             | XX                 | X            | X                |

### Commercial

| Shell Style | Service Class | Contacts & Accessories | Shell Style | Shell Size | Insert Arrangement | Contact Type | Alternate Keying | Contact Plating | Deviations/Specials |
|-------------|---------------|------------------------|-------------|------------|--------------------|--------------|------------------|-----------------|---------------------|
| ZZY         | X             | X                      | 15          | XX         | XX                 | X            | X                | X               | XXX                 |

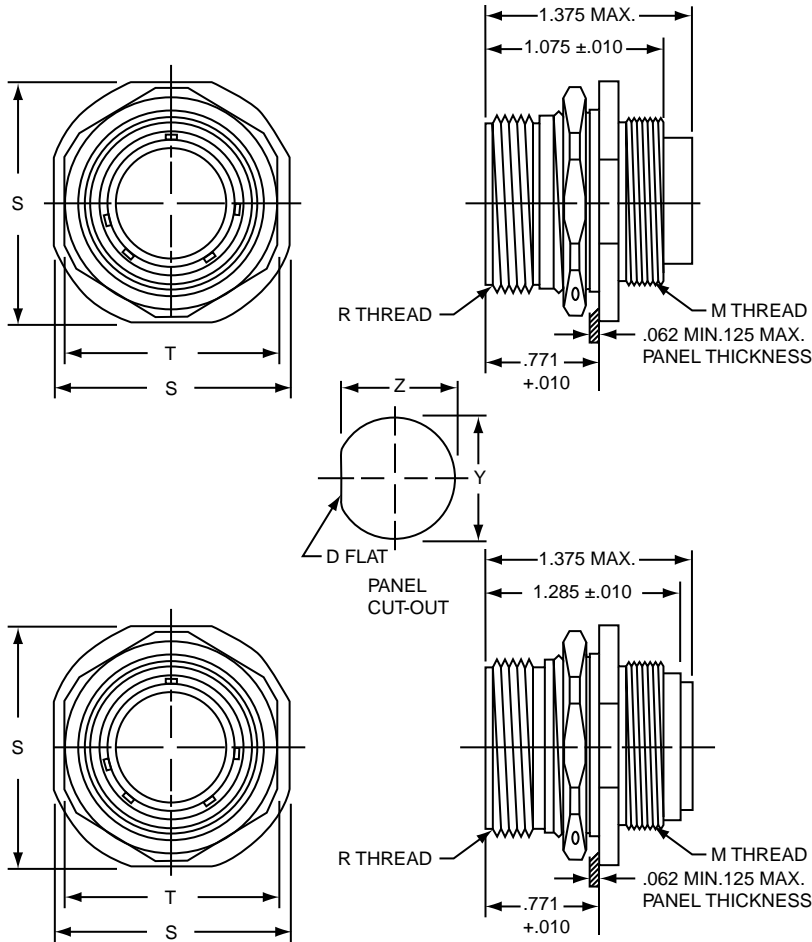

**STAINLESS STEEL**  
Pyle ZZY-RX-15XX Series  
MS24265EXXTXX  
Military Class E

**ALUMINUM**  
Pyle ZZY-XX-15XX Series  
MS24265RXXTXX  
Military Class R

| Shell Size | M Cable Support Thread |                        | Aluminum Connector Weight (lbs.) max including Contacts |               | R Coupling Thread | S Flange Width ±.005 | T Lock Nut Flats |       | Y Dia Mounting Hole | Z Flat Mounting Hole | Rec. min. Torque Jam Nut Inch/Lbs. |
|------------|------------------------|------------------------|---|---------------|-------------------|----------------------|------------------|-------|---------------------|----------------------|------------------------------------|
|            | Steel NS-2A            | Alum. UNEF-2A Modified | Pin Insert  | Socket Insert |                   |                      | Steel            | Alum. |                     |                      |                                    |
| 08         | NA                     | NA                     | NA  | NA            | NA                | NA                   | NA               | NA    | NA                  | NA                   | NA                                 |
| 10         | .563-36                | .562-24                | .049  | .050          | 1.171-24          | 1.104                | .937             | .937  | .760                | .730                 | 36                                 |
| 12**       | NA                     | .750-20                | .069  | .070          | .875-20           | 1.291                | 1.125            | 1.125 | .947                | .917                 | 56                                 |
| 14         | .803-36                | .812-20                | .087  | .089          | .937-20           | 1.391                | 1.062            | 1.187 | 1.010               | .980                 | 65                                 |
| 16         | .930-36                | .937-20                | .104  | .106          | 1.062-18          | 1.516                | 1.187            | 1.312 | 1.135               | 1.105                | 69                                 |
| 18         | 1.036-36               | 1.062-18               | .131  | .133          | 1.187-18          | 1.614                | 1.312            | 1.437 | 1.260               | 1.225                | 81                                 |
| 20         | NA                     | NA                     | .152  | .157          | NA                | NA                   | NA               | NA    | NA                  | NA                   | 100                                |
| 22         | 1.286-36               | 1.312-18               | .181  | .187          | 1.312-18          | 1.954                | 1.562            | 1.687 | 1.510               | 1.475                | 123                                |
| 24         | 1.411-36               | 1.437-18               | .208  | .212          | NA                | NA                   | NA               | NA    | NA                  | NA                   | 133                                |
| 28         | NA                     | NA                     | NA  | NA            | NA                | NA                   | NA               | NA    | NA                  | NA                   | NA                                 |

NA designates not available. \*\* Not available in Stainless Steel.  
All dimensions for reference only.

38999  
SJT I II III

26482  
Matrix 2

83723 III  
Matrix Pyle

5015  
Crimp Rear Release Matrix

26500 Pyle

Printed  
Circuit Board

EMI Filter  
Transient

Fiber Optics

High Speed  
Contacts

Options  
Others

# MS24266, Pyle® ZZY, MIL-DTL-26500

## Straight Plug, Threaded



### Part #

To complete see how to order pages 207

### Military

| Shell Style | Service Class | Shell Size | Coupling Type | Insert Arrangement | Contact Type | Alternate Keying |
|-------------|---------------|------------|---------------|--------------------|--------------|------------------|
| MS24266     | E or R        | XX         | T             | XX                 | X            | X                |

### Commercial

| Shell Style | Service Class | Contacts & Accessories | Shell Style | Shell Size | Insert Arrangement | Contact Type | Alternate Keying | Contact Plating | Deviations/Specials |
|-------------|---------------|------------------------|-------------|------------|--------------------|--------------|------------------|-----------------|---------------------|
| ZZY         | X             | X                      | 10          | XX         | XX                 | X            | X                | X               | XXX                 |

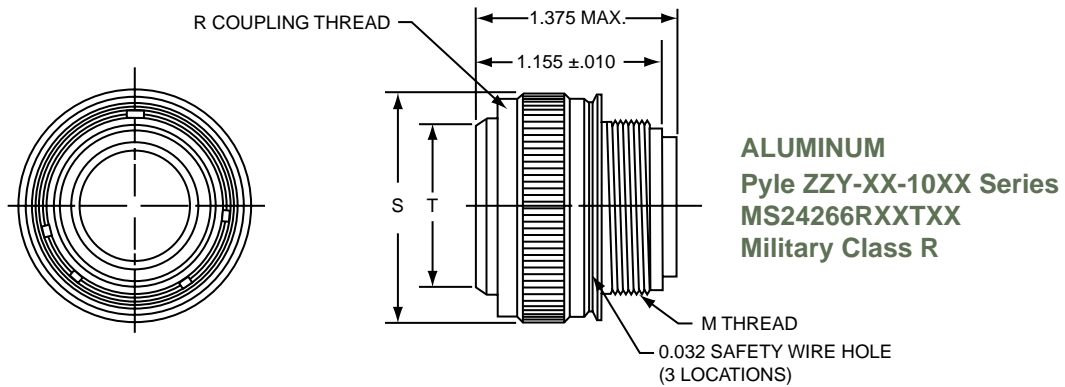
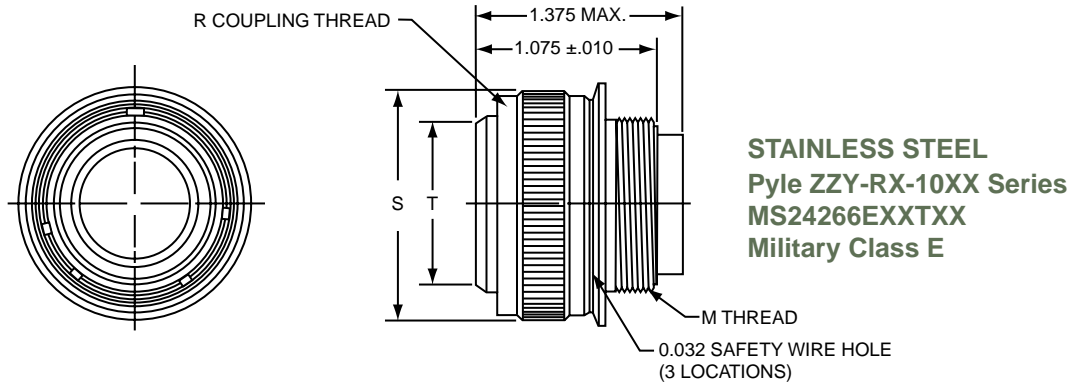

| Shell Size | M Cable Support Thread |                        | Aluminum Connector Weight (lbs.) max including Contacts |               | R Coupling Thread | S Dia. Max Coupling Nut |       | T Shell Dia. +.000 - .005 |
|------------|------------------------|------------------------|---|---------------|-------------------|-------------------------|-------|---------------------------|
|            | Steel NS-2A            | Alum. UNEF-2A Modified | Pin Insert  | Socket Insert |                   | Steel                   | Alum. |                           |
| 08**       | NA                     | .437-28                | .030  | .031          | .562-24           | NA                      | .776  | .424                      |
| 10         | .563-36                | .562-24                | .044  | .045          | .687-24           | .826                    | .906  | .526                      |
| 12         | .733-36                | .750-20                | .063  | .064          | .875-20           | .996                    | 1.078 | .696                      |
| 14         | .803-36                | .812-20                | .074  | .076          | .937-20           | 1.066                   | 1.141 | .765                      |
| 16         | .930-36                | .937-20                | .091  | .094          | 1.062-18          | 1.193                   | 1.266 | .892                      |
| 18         | 1.036-36               | 1.062-18               | .110  | .112          | 1.187-18          | 1.299                   | 1.375 | .998                      |
| 20         | 1.161-36               | 1.187-18               | .133  | .136          | 1.312-18          | 1.424                   | 1.510 | 1.123                     |
| 22         | 1.286-36               | 1.286-18               | .154  | .160          | 1.437-18          | 1.549                   | 1.625 | 1.248                     |
| 24         | 1.411-36               | 1.437-18               | .184  | .188          | 1.562-18          | 1.674                   | 1.670 | 1.373                     |
| 28†        | 1.661-36               | NA                     | NA  | NA            | 1.812-16          | 1.912                   | NA    | 1.623                     |

NA designates not available. \*\* Not available in Stainless Steel. † Not available in Aluminum.  
All dimensions for reference only.

III  
II  
I  
SJT  
38999

Matrix 2  
26482

Matrix  
Pyle  
83723 III

Crimp Rear  
Release Matrix  
5015

26500 Pyle

Printed  
Circuit Board

EMI Filter  
Transient

Fiber Optics

High Speed  
Contacts

Options  
Others

### Part #

To complete see how to order pages 207

### Military

| Shell Style | Service Class | Shell Size | Coupling Type | Insert Arrangement | Contact Type | Alternate Keying |
|-------------|---------------|------------|---------------|--------------------|--------------|------------------|
| MS24264     | E or R        | XX         | B             | XX                 | X            | X                |

### Commercial

| Shell Style | Service Class | Contacts & Accessories | Shell Style | Shell Size | Insert Arrangement | Contact Type | Alternate Keying | Contact Plating | Deviations/Specials |
|-------------|---------------|------------------------|-------------|------------|--------------------|--------------|------------------|-----------------|---------------------|
| ZZW         | X             | X                      | 17          | XX         | XX                 | X            | X                | X               | XXX                 |

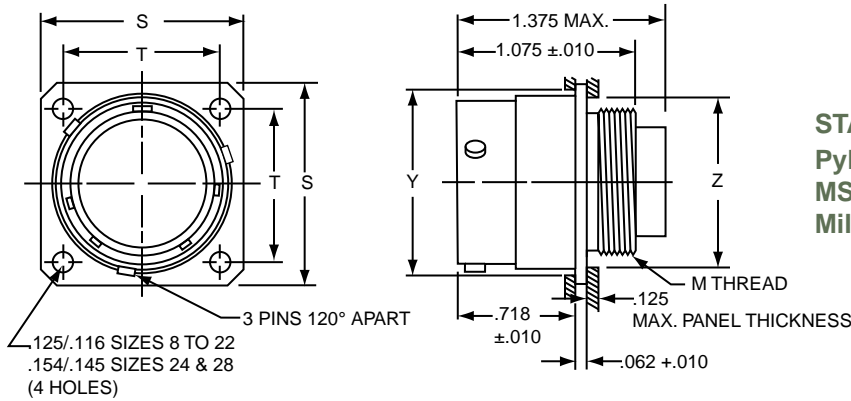

**STAINLESS STEEL**  
Pyle ZZW-RX-17XX Series  
MS24264EXXBXX  
Military Class E

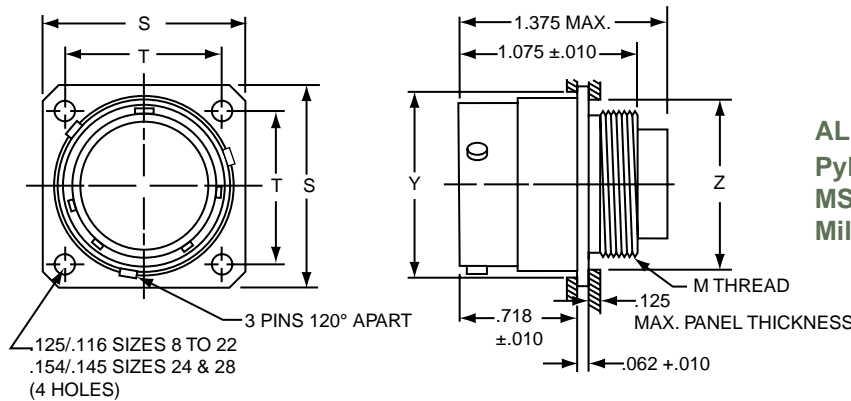

**ALUMINUM**  
Pyle ZZW-XX-17XX Series  
MS24264RXXBXX  
Military Class R

| Shell Size | M Cable Support Thread |                        | Aluminum Connector Weight (lbs.) max including Contacts |               | S Flange Width ±.005 | T Mounting Hole Centers ±.005 | Y Back Mount Min. Hole | Z Front Mount Min. Hole |
|------------|------------------------|------------------------|---|---------------|----------------------|-------------------------------|------------------------|-------------------------|
|            | Steel NS-2A            | Alum. UNEF-2A Modified | Pin Insert  | Socket Insert |                      |                               |                        |                         |
| 08**       | NA                     | .437-28                | .025  | .026          | .812                 | .594                          | .606                   | .443                    |
| 10         | .563-36                | .562-24                | .042  | .044          | .937                 | .719                          | .748                   | .572                    |
| 12         | .733-36                | .750-20                | .061  | .062          | 1.031                | .812                          | .913                   | .760                    |
| 14         | .803-36                | .812-20                | .072  | .074          | 1.125                | .906                          | .980                   | .822                    |
| 16         | .930-36                | .937-20                | .087  | .090          | 1.250                | .969                          | 1.107                  | .948                    |
| 18         | 1.036-36               | 1.062-18               | .110  | .112          | 1.343                | 1.062                         | 1.209                  | 1.072                   |
| 20         | 1.161-36               | 1.187-18               | .130  | .134          | 1.437                | 1.156                         | 1.325                  | 1.197                   |
| 22         | 1.286-36               | 1.312-18               | .152  | .159          | 1.562                | 1.250                         | 1.452                  | 1.322                   |
| 24**       | NA                     | 1.437-18               | .181  | .188          | 1.703                | 1.375                         | 1.577                  | 1.447                   |
| 28         | NA                     | NA                     | NA  | NA            | NA                   | NA                            | NA                     | NA                      |

NA designates not available. \*\* Not available in Stainless Steel. All dimensions for reference only.

38999  
SJT I II III

26482  
Matrix 2

83723 III  
Matrix Pyle

5015  
Crimp Rear Release Matrix

26500 Pyle

Printed  
Circuit Board

EMI Filter  
Transient

Fiber Optics

High Speed  
Contacts

Options  
Others



# MS24265, Pyle® (ZZW), MIL-DTL-26500

## Single Hole (D-Hole) Mounted Receptacle, Bayonet



### Part #

To complete see how to order pages 207

### Military

| Shell Style | Service Class | Shell Size | Coupling Type | Insert Arrangement | Contact Type | Alternate Keying |
|-------------|---------------|------------|---------------|--------------------|--------------|------------------|
| MS24265     | E or R        | XX         | B             | XX                 | X            | X                |

### Commercial

| Shell Style | Service Class | Contacts & Accessories | Shell Style | Shell Size | Insert Arrangement | Contact Type | Alternate Keying | Contact Plating | Deviations/Specials |
|-------------|---------------|------------------------|-------------|------------|--------------------|--------------|------------------|-----------------|---------------------|
| ZZW         | X             | X                      | 15          | XX         | XX                 | X            | X                | X               | XXX                 |

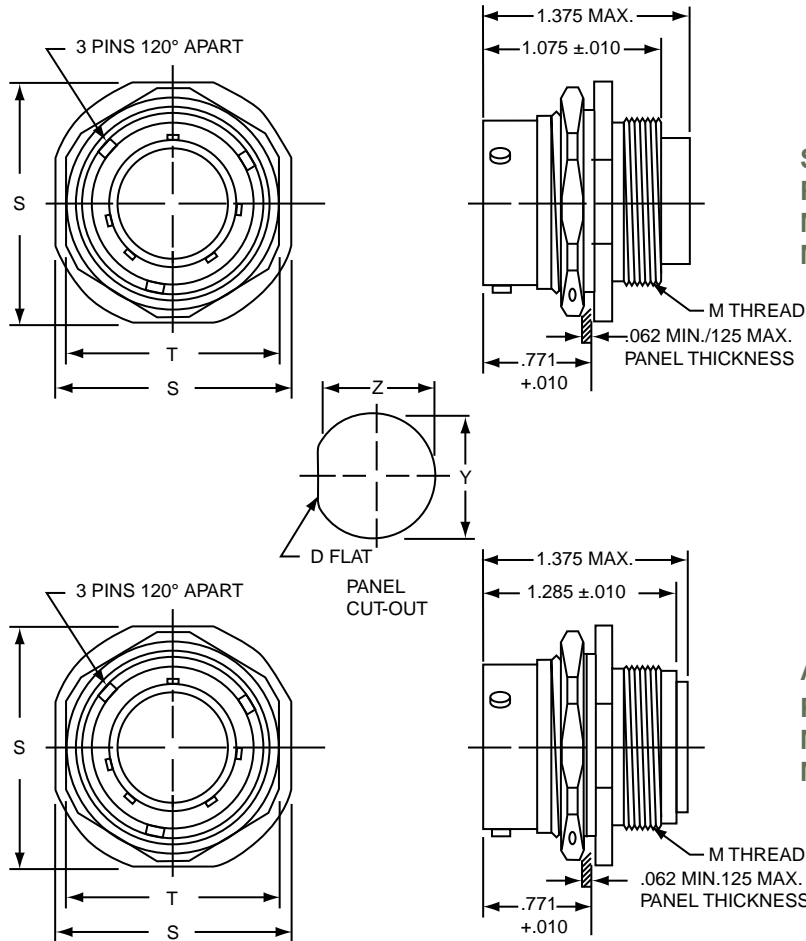

**STAINLESS STEEL**  
**Pyle ZZW-RX-15XX Series**  
**MS24265EXXBXX**  
**Military Class E**

**ALUMINUM**  
**Pyle ZZW-XX-15XX Series**  
**MS24265RXXBXX**  
**Military Class R**

| Shell Size | M Cable Support Thread |                        | Aluminum Connector Weight (lbs.) max including Contacts |               | S Flange Width ±.005 | T Lock Nut Flats |       | Y Dia Mounting Hole | Z Flat Mounting Hole | Recom. min. Torque Jam Nut Lb. - inches |
|------------|------------------------|------------------------|---|---------------|----------------------|------------------|-------|---------------------|----------------------|---|
|            | Steel NS-2A            | Alum. UNEF-2A Modified | Pin Insert  | Socket Insert |                      | Steel            | Alum. |                     |                      |   |
| 08**       | NA                     | .437-28                | .029  | .030          | .979                 | NA               | .812  | .635                | .605                 | 33                                      |
| 10         | .563-36                | .562-24                | .049  | .050          | 1.104                | .937             | .937  | .760                | .730                 | 36                                      |
| 12**       | NA                     | .750-20                | .069  | .070          | 1.291                | 1.125            | 1.125 | .947                | .917                 | 56                                      |
| 14         | .803-36                | .812-20                | .087  | .089          | 1.391                | 1.062            | 1.187 | 1.010               | .980                 | 65                                      |
| 16         | .930-36                | .937-20                | .104  | .106          | 1.561                | 1.187            | 1.312 | 1.135               | 1.105                | 69                                      |
| 18         | 1.036-36               | 1.062-18               | .131  | .133          | 1.641                | 1.312            | 1.437 | 1.260               | 1.225                | 81                                      |
| 20         | 1.161-36               | 1.187-18               | .152  | .157          | 1.766                | 1.562            | NA    | 1.385               | 1.350                | 100                                     |
| 22         | 1.286-36               | 1.312-18               | .181  | .187          | 1.954                | 1.585            | 1.687 | 1.510               | 1.475                | 123                                     |
| 24         | 1.411-36               | 1.437-18               | .208  | .212          | 2.079                | 1.687            | 1.812 | 1.635               | 1.600                | 133                                     |
| 28         | NA                     | NA                     | NA  | NA            | NA                   | NA               | NA    | NA                  | NA                   | NA                                      |

NA designates not available. \*\* Not available in Stainless Steel. All dimensions for reference only.

- III 38999
- II 26482 Matrix 2
- I 83723 III Matrix Pyle
- SJT 5015 Crimp Rear Release Matrix
- 26500 Pyle
- Printed Circuit Board
- EMI Filter Transient
- Fiber Optics
- High Speed Contacts
- Options Others

### Part #

To complete see how to order pages 207

### Military

| Shell Style | Service Class | Shell Size | Coupling Type | Insert Arrangement | Contact Type | Alternate Keying |
|-------------|---------------|------------|---------------|--------------------|--------------|------------------|
| MS24266     | E or R        | XX         | B             | XX                 | X            | X                |

### Commercial

| Shell Style | Service Class | Contacts & Accessories | Shell Style | Shell Size | Insert Arrangement | Contact Type | Alternate Keying | Contact Plating | Deviations/ Specials |
|-------------|---------------|------------------------|-------------|------------|--------------------|--------------|------------------|-----------------|----------------------|
| ZZW         | X             | X                      | 10          | XX         | XX                 | X            | X                | X               | XXX                  |

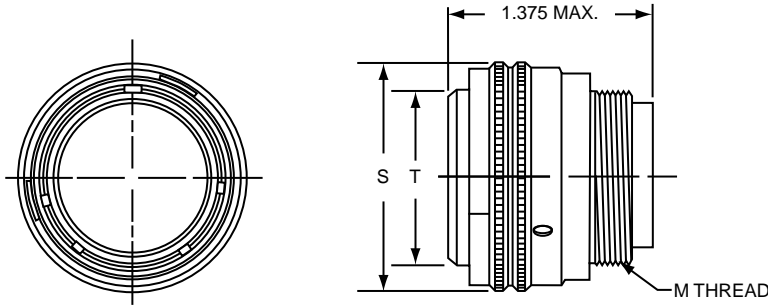

**STAINLESS STEEL**  
Pyle ZZW-RX-10XX Series  
MS24266EXXBXX  
Military Class E

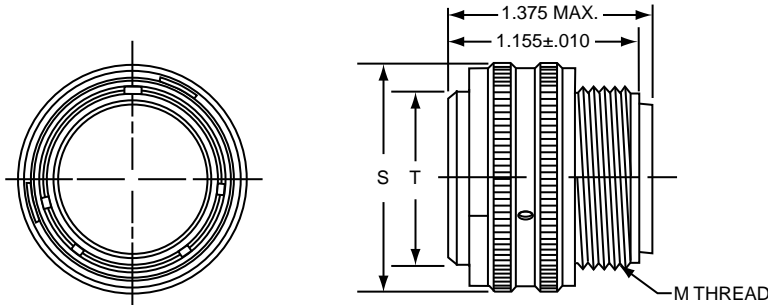

**ALUMINUM**  
Pyle ZZW-XX-10XX Series  
MS24266RXXBXX  
Military Class R

| Shell Size | M Cable Support Thread |                        | Aluminum Connector Weight (lbs.) max including Contacts |               | S Dia Max. Coupling Nut |       | T Shell Dia. +.000 - .005 |
|------------|------------------------|------------------------|---|---------------|-------------------------|-------|---------------------------|
|            | Steel NS-2A            | Alum. UNEF-2A Modified | Pin Insert  | Socket Insert | Steel                   | Alum. |                           |
| 08**       | NA                     | .437-28                | .030  | .031          | NA                      | .762  | .424                      |
| 10         | .563-36                | .562-24                | .044  | .045          | .848                    | .904  | .526                      |
| 12         | .733-36                | .750-20                | .063  | .064          | 1.018                   | 1.076 | .696                      |
| 14         | .803-36                | .812-20                | .074  | .076          | 1.087                   | 1.122 | .765                      |
| 16         | .930-36                | .937-20                | .091  | .094          | 1.214                   | 1.264 | .892                      |
| 18         | 1.036-36               | 1.062-18               | .110  | .112          | 1.320                   | 1.373 | .998                      |
| 20         | 1.161-36               | 1.187-18               | .133  | .136          | 1.445                   | 1.503 | 1.123                     |
| 22         | 1.286-36               | 1.312-18               | .154  | .160          | 1.570                   | 1.623 | 1.248                     |
| 24         | 1.411-36               | 1.437-18               | .184  | .188          | 1.695                   | 1.752 | 1.373                     |
| 28         | NA                     | NA                     | NA  | NA            | NA                      | NA    | NA                        |

NA designates not available. \*\* Not available in Stainless Steel.  
All dimensions for reference only.

38999  
SJT I II III

26482  
Matrix 2

83723 III  
Matrix Pyle

5015  
Crimp Rear Release Matrix

26500 Pyle

Printed  
Circuit Board

EMI Filter  
Transient

Fiber Optics

High Speed  
Contacts

Options  
Others

# Pyle® (ZZY), MIL-DTL-26500 Ratchet Lock Plug, New Non-Decoupling Plug



**Part #** To complete see how to order pages 207 **Commercial**

| Shell Style | Service Class | Contacts & Accessories* | Shell Style | Shell Size | Insert Arrangement | Contact Type | Alternate Keying | Contact Plating | Deviations/Specials |
|-------------|---------------|-------------------------|-------------|------------|--------------------|--------------|------------------|-----------------|---------------------|
| ZZY         | X             | X                       | 12          | XX         | XX                 | X            | X                | X               | XXX                 |
| ZZY         | X             | X                       | 13          | XX         | XX                 | X            | X                | X               | XXX                 |

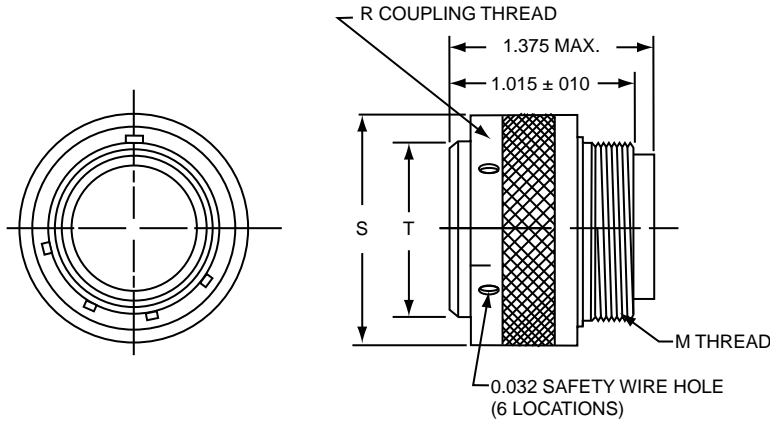

**RATCHET LOCK PLUG**  
STAINLESS STEEL/  
ALUMINUM  
Pyle ZZY-XX-12XX  
Series

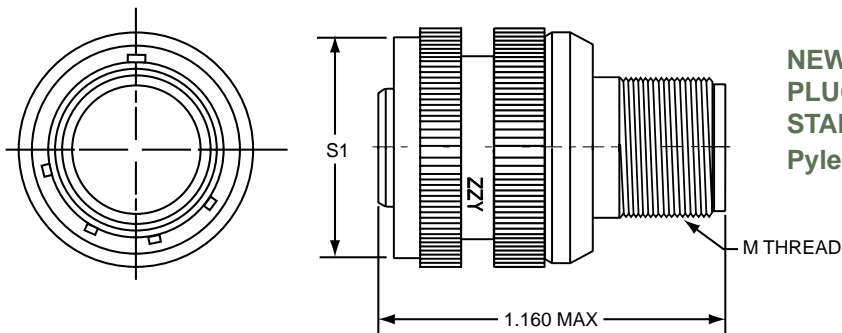

**NEW NON-DECOUPLING PLUG**  
STAINLESS STEEL  
Pyle ZZY-RX-13XX Series

| Shell Size | M Thread Cable Support | R Thread Coupling | S Dia Coupling Nut | S1 Dia Coupling Nut | T Shell Dia. |
|------------|------------------------|-------------------|--------------------|---------------------|--------------|
| 08         | .434-36                | .562-24           | .800               | .820                | .424         |
| 10         | .563-36                | .687-24           | .934               | .946                | .526         |
| 12         | .733-36                | .875-20           | 1.114              | 1.088               | .696         |
| 14         | .803-36                | .937-20           | 1.178              | 1.191               | .765         |
| 16         | .930-36                | 1.062-18          | 1.305              | 1.314               | .892         |
| 18         | 1.036-36               | 1.312-18          | 1.411              | 1.420               | .998         |
| 20         | 1.161-36               | 1.312-18          | 1.550              | 1.545               | 1.123        |
| 22         | 1.286-36               | 1.437-18          | 1.661              | 1.670               | 1.248        |
| 24         | 1.411-36               | 1.562-18          | 1.786              | 1.805               | 1.373        |
| 28         | 1.661-36               | 1.812-16          | 2.041              | 2.110               | 1.623        |

All dimensions for reference only.

III  
II  
I  
SJT  
38999

Matrix 2  
26482

Matrix  
Pyle  
83723 III

Crimp Rear  
Release Matrix  
5015

26500 Pyle

Printed  
Circuit Board

EMI Filter  
Transient

Fiber Optics

High Speed  
Contacts

Options  
Others

**Part #** To complete see how to order pages 208

**Commercial**

| Shell Style | Service Class | Contacts & Accessories* | Shell Style | Shell Size | Insert Arrangement | Contact Type | Alternate Keying | Contact Plating | Deviations/Specials |
|-------------|---------------|-------------------------|-------------|------------|--------------------|--------------|------------------|-----------------|---------------------|
| ZZY         | X             | X                       | 12 or 13    | XX         | XX                 | X            | X                | X               | XXX                 |

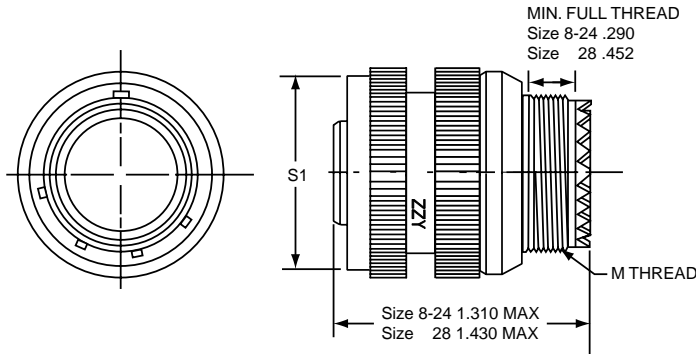

### NEW NON-DECOUPLING PLUG MATING

Serrations per MS3155  
STAINLESS STEEL/ALUMINUM  
Pyle ZZY- XX-13XXX Series

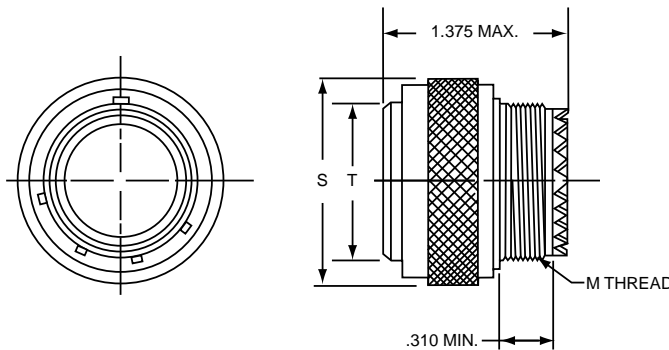

### RATCHET LOCK PLUG

With MIL-DTL-83723 Accessory  
Serrations per MS3155  
STAINLESS STEEL/ALUMINUM  
Pyle ZZY- XX-12XXX Series

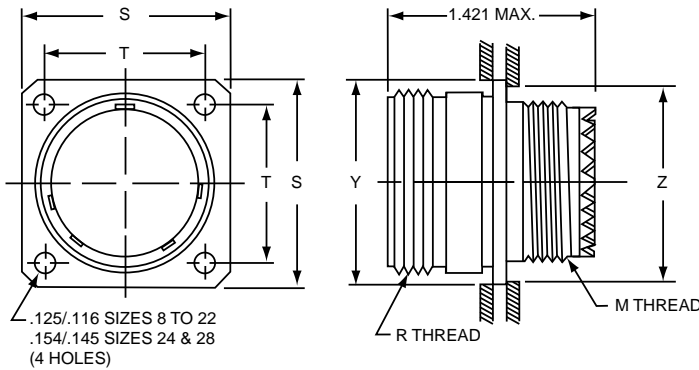

### MATING SQUARE FLANGE MOUNTED, THREADED RECEPTACLE

STAINLESS STEEL/ALUMINUM  
Pyle ZZY-XX-17XX Series

| Shell Size | Plug                   |                         |                           |                   | Receptacle           |                     |                               |                          |                           |
|------------|------------------------|-------------------------|---------------------------|-------------------|----------------------|---------------------|-------------------------------|--------------------------|---------------------------|
|            | M Thread Cable Support | S Dia Max. Coupling Nut | T Shell Dia. +.000 - .005 | R Coupling Thread | S Flange Width ±.005 | S1 Dia Coupling Nut | T Mounting Hole Centers ±.005 | Y Back Mount Hole (min.) | Z Front Mount Hole (min.) |
| 08         | NA                     | NA                      | NA                        | NA                | NA                   | .820                | NA                            | NA                       | NA                        |
| 10         | .6250-24               | .945                    | .526                      | .6875-24          | .937                 | .946                | .719                          | .706                     | .635                      |
| 12         | .7500-20               | 1.165                   | .696                      | .8750-20          | 1.031                | 1.088               | .812                          | .885                     | .760                      |
| 14         | .8750-20               | 1.230                   | .765                      | .9375-20          | 1.125                | 1.191               | .906                          | .947                     | .885                      |
| 16         | 1.0000-20              | 1.353                   | .892                      | 1.0625-18         | 1.250                | 1.314               | .969                          | 1.072                    | 1.010                     |
| 18         | 1.0625-18              | 1.468                   | .998                      | 1.1875-18         | 1.343                | 1.420               | 1.062                         | 1.197                    | 1.072                     |
| 20         | 1.1875-18              | 1.607                   | 1.123                     | 1.3125-18         | 1.437                | 1.545               | 1.156                         | 1.322                    | 1.197                     |
| 22         | 1.3125-18              | 1.733                   | 1.248                     | 1.4375-18         | 1.562                | 1.670               | 1.250                         | 1.447                    | 1.322                     |
| 24         | 1.4375-18              | 1.858                   | 1.373                     | 1.5625-18         | 1.703                | 1.805               | 1.375                         | 1.572                    | 1.448                     |
| 28         | 1.7500-18              | 2.113                   | 1.623                     | 1.8120-16         | 2.000                | 2.110               | 1.562                         | 1.822                    | 1.760                     |

NA designates not available. All dimensions for reference only.

38999  
SJT I II III

26482  
Matrix 2

83723 III  
Matrix Pyle

5015  
Crimp Rear  
Release Matrix

26500 Pyle

Printed  
Circuit Board





EMI Filter  
Transient

Fiber Optics



High Speed  
Contacts

Options  
Others

## THREADED COUPLING, FIREWALL, PYLE FPK, FPL, FP5K, MS2761X-KXXTXX

| Shell Style<br>(Firewall stainless steel only)   | Basic<br>Performance Level   | Hardware<br>Description*         | Class*                         | Basic Part Number**                  |
|--|--|----------------------------------|--------------------------------|--------------------------------------|
|  <p>Square Flange Mounted Receptacle Threaded Coupling</p>        | High performance. Environmentally sealed. Resists high temperatures up to 238°C (460°F). | Class K Firewall Stainless Steel | Military Class K               | MS27613-KXXTXX                       |
|  |  |                                  | Pyle FPK or FPL or FP5K Series | FPK-17( ) or FPL-17( ) or FP5K-17( ) |
|  <p>Single Hole (D-Hole) Mounted Receptacle Threaded Coupling</p> | High performance. Environmentally sealed. Resists high temperatures up to 238°C (460°F). | Class K Firewall Stainless Steel | Military Class K               | MS27614-KXXTXX                       |
|  |  |                                  | Pyle FPK or FPL or FP5K Series | FPK-19( ) or FPL-19( ) or FP5K-19( ) |
|  <p>Straight Plug Threaded Coupling</p>                           | High performance. Environmentally sealed. Resists high temperatures up to 238°C (460°F). | Class K Firewall Stainless Steel | Military Class K               | MS27615-KXXTXX                       |
|  |  |                                  | Pyle FPK or FPL                | FPK-11( ) or FPL-11( )               |
|  <p>Ratchet Locking Plug Threaded Coupling</p>                   | High performance. Environmentally sealed. Resists high temperatures up to 238°C (460°F). | Class K Firewall Stainless Steel | Meets Military Class K         | Consult Amphenol                     |
|  |  |                                  | Pyle FPK or FPL or FP5K Series | FPK-12( ) or FPL-12( ) or FP5K-12( ) |

## BAYONET COUPLING, FIREWALL, PYLE FYL, MS2761X-KXXBXX

| Shell Style<br>(Firewall stainless steel only)  | Basic<br>Performance Level   | Hardware<br>Description*         | Class*           | Basic Part Number** |
|---|--|----------------------------------|------------------|---------------------|
|  <p>Square Flange Mounted Receptacle Bayonet Coupling</p>        | High performance. Environmentally sealed. Resists high temperatures up to 238°C (460°F). | Class K Firewall Stainless Steel | Military Class K | MS27613-KXXBXX      |
|   |  |                                  | Pyle FYL Series  | FYL-17( )           |
|  <p>Single Hole (D-Hole) Mounted Receptacle Bayonet Coupling</p> | High performance. Environmentally sealed. Resists high temperatures up to 238°C (460°F). | Class K Firewall Stainless Steel | Military Class K | MS27614-KXXBXX      |
|   |  |                                  | Pyle FYL Series  | FYL-19( )           |
|  <p>Straight Plug Bayonet Coupling</p>                           | High performance. Environmentally sealed. Resists high temperatures up to 238°C (460°F). | Class K Firewall Stainless Steel | Military Class K | MS27615-KXXBXX      |
|   |  |                                  | Pyle FYL Series  | FYL-11( )           |

\* See how to order, page 218, for further description of hardware classes.  
 \*\* See how to order, page 218, to complete part numbers.

38999  
III II I SJT

26482  
Matrix 2

83723 III  
Matrix Pyle

5015  
Crimp Rear Release Matrix

26500 Pyle

Printed  
Circuit Board

EMI Filter  
Transient

Fiber Optics

High Speed  
Contacts

Options  
Others

**Easy Steps to build a part number... Military**

| 1. Shell Style | 2. Service Class | 3. Shell Size | 4. Coupling Type | 5. Insert Arrangement | 6. Contact Type | 7. Alternate Keying | 8. Cable Support |
|----------------|------------------|---------------|------------------|-----------------------|-----------------|---------------------|------------------|
| MS27613        | K                | 14            | T                | 7                     | P               | 6                   | D                |

**Step 1. Select a Shell Style**

|         | Designates                      |
|---------|---------------------------------|
| MS27613 | Square Flange Receptacle        |
| MS27614 | Single Hole Mounting Receptacle |
| MS27615 | Straight Plug                   |

**Step 2. Select a Service Class**

|   | Designates                             |
|---|--|
| K | Firewall - Stainless steel, passivated |

**Step 3. Select a Shell Size**

|    |    |    |    |    |    |    |
|----|----|----|----|----|----|----|
| 12 | 14 | 16 | 18 | 22 | 24 | 28 |
|----|----|----|----|----|----|----|

**Step 4. Select a Coupling Type**

|   | Designates |
|---|------------|
| T | Threaded   |
| B | Bayonet    |

For Ratchet Lock Plug and New Non-Decoupling Consult Amphenol

**Step 5. Select an Insert Arrangement on pages 203 & 204**

Shell Size & Insert Arrangements are on pages 203 & 204. First number represents Shell Size, second number is the Insert Arrangement.

**Step 6. Select a Contact Type**

|   | Designates      |
|---|-----------------|
| P | Pin Contacts    |
| S | Socket Contacts |

**Step 7. Select an Alternate Keying Position**

6, 7, 8, 9, Y (N for Normal) See page 204

**Step 8. Select a Cable Support**

|   | Designates                  |
|---|-----------------------------|
| D | Long Straight (MS27658)     |
| P | Standard Straight (MS27657) |
| J | Right Angle (MS27659)       |

(omit for normal)  
See page 233

**Easy Steps to build a part number... Commercial**

| 1. Connector Type | 2. Shell Style | 3. Shell Size | 4. Insert Arrangement | 5. Contact Type | 6. Less Contact/Contact Plating | 7. Alternate Keying | 8. Cable Support | 9. Deviations/Specials |
|-------------------|----------------|---------------|-----------------------|-----------------|---------------------------------|---------------------|------------------|------------------------|
| FPK               | 11             | 28            | 42                    | S               | T                               | 06                  | D                | XXX                    |

**Step 1. Select a Shell Style**

|      | Designates (Firewall, Class K Styles)                           |
|------|---|
| FPK  | Threaded coupling, qualified to MIL-DTL-26500 and BACC63 Series |
| FPL  | Threaded coupling, same as FPK, but used on Lockheed Aircraft   |
| FP5K | Threaded Coupling, qualified for General Electric               |
| FYL  | Bayonet Coupling, qualified to MIL-DTL-26500                    |

**Step 4. Select an Insert Arrangement on pages 203 & 204**

Shell Size & Insert Arrangements are on page 203 & 204. First number represents Shell Size, second number is the Insert Arrangement.

**Step 7. Select an Alternate Keying Position**

6, 7, 8, 9, Y (N for Normal) See page 204

**Step 8. Select a Cable Support**

|   | Designates        |
|---|-------------------|
| D | Long Straight     |
| P | Standard Straight |
| J | Right Angle       |

(omit for normal)  
See page 233

**Step 2. Select a Shell Type**

|    | Designates                    |
|----|-------------------------------|
| 11 | Straight Plug                 |
| 12 | Ratchet Locking Threaded Plug |
| 13 | Improved Non-Decoupling Plug  |
| 17 | Square Flange Receptacle      |
| 19 | D-Hole Mounting Receptacle    |

**Step 5. Select a Contact Type**

|   | Designates      |
|---|-----------------|
| P | Pin Contacts    |
| S | Socket Contacts |

**Step 6. Select a Contact/Contact Plating**

|   | Designates    |
|---|---------------|
| E | No Contacts   |
| T | Rhodium       |
| D | Gold Contacts |

**Step 9. Deviations/Specails**

Please consult Amphenol for more information.

**Step 3. Select a Shell Size**

|    |    |    |    |    |    |    |
|----|----|----|----|----|----|----|
| 12 | 14 | 16 | 18 | 22 | 24 | 28 |
|----|----|----|----|----|----|----|

38999  
SJT I II III

26482  
Matrix 2

83723 III  
Matrix Pyle

5015  
Crimp Rear Release Matrix

26500 Pyle

Printed  
Circuit Board

EMI Filter  
Transient

Fiber Optics

High Speed  
Contacts

Options  
Others



### Easy Steps to build a part number... Per Boeing Company

| 1.              | 2.                   | 3.         | 4.         | 5.          | 6.                 | 7.           | 8.               |
|-----------------|----------------------|------------|------------|-------------|--------------------|--------------|------------------|
| Boeing Aircraft | Electrical Connector | Shell Type | Shell Size | Accessories | Insert Arrangement | Contact Type | Alternate Keying |
| BAC             | C                    | 63X        | 14         | S           | T                  | 06           | D                |

#### Step 1. Boeing Aircraft

|     | Designates              |
|-----|-------------------------|
| BAC | Boeing Aircraft Company |

#### Step 2. Electrical Connector

|   | Designates           |
|---|----------------------|
| E | Electrical Connector |

#### Step 3. Select a Shell Type

|      | Designates   |
|------|--|
| 63X  | Plug, Threaded, Fire Barrier   |
| 63Y  | Receptacle, Threaded Fire Barrier  |
| 63AE | Plug, Threaded, for use with No. 20 Wire Fire Barrier                                    |
| 63AF | Receptacle, Flange Mount, Threaded, Fire Barrier, For use with No. 20 Wire Fire Barrier. |

Note: AE & AF require W11 variation on Pyle Number.

#### Step 4. Select a Shell Size

|    |    |    |    |    |    |    |
|----|----|----|----|----|----|----|
| 12 | 14 | 16 | 18 | 22 | 24 | 28 |
|----|----|----|----|----|----|----|

#### Step 5. Accessories

|   | Designates  |
|---|---|
| C | To order with D Cable Clamp replace – with Letter C |

#### Step 6. Select an Insert Arrangement on pages 201 & 202

Shell Size & Insert Arrangements are on page 201 & 202. First number represents Shell Size, second number is the Insert Arrangement.

#### Step 7. Select a Contact Type

|   | Designates      |
|---|-----------------|
| P | Pin Contacts    |
| S | Socket Contacts |

#### Step 8. Select an Alternate Keying Position

6, 7, 8, 9, Y (N for Normal) See page 202

III  
II  
I  
SJT  
38999

Matrix 2  
26482

Matrix Pyle  
83723 III

Crimp Rear Release Matrix  
5015

26500 Pyle

Printed Circuit Board

EMI Filter Transient

Fiber Optics

High Speed Contacts

Options Others

### Part #

To complete see how to order pages 218

### Military

| Shell Style | Service Class | Shell Size | Coupling Type | Insert Arrangement | Contact Type | Alternate Keying | Cable Support |
|-------------|---------------|------------|---------------|--------------------|--------------|------------------|---------------|
| MS27613     | K             | XX         | B or T        | XX                 | X            | X                | X             |

### Commercial

| Connector Type | Shell Style | Shell Size | Insert Arrangement | Contact Type | Contact Style | Alternate Keying | Cable Support | Deviations/Specials |
|----------------|-------------|------------|--------------------|--------------|---------------|------------------|---------------|---------------------|
| FPK or FYL     | 17          | X          | XX                 | XX           | X             | X                | X             | XXX                 |

### THREADED COUPLING

Class K Stainless Steel  
Pyle FPK-17XX Series  
MS27613KXXTXX  
Military Class K

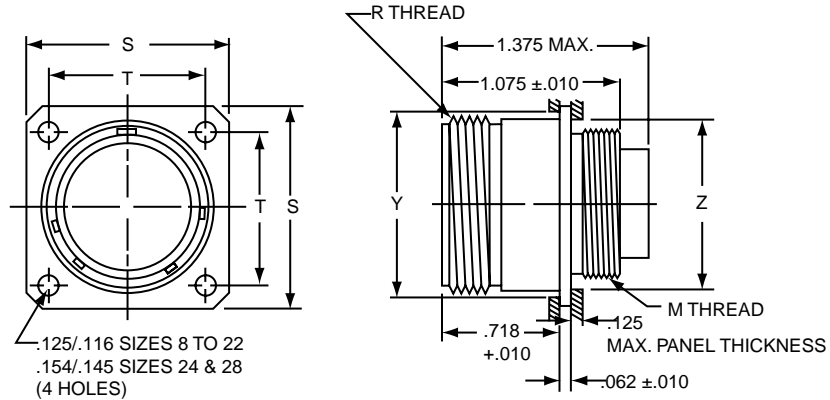

### BAYONET COUPLING

Class K Stainless Steel  
Pyle FYL-17XX Series  
MS27613KXXBXX  
Military Class K

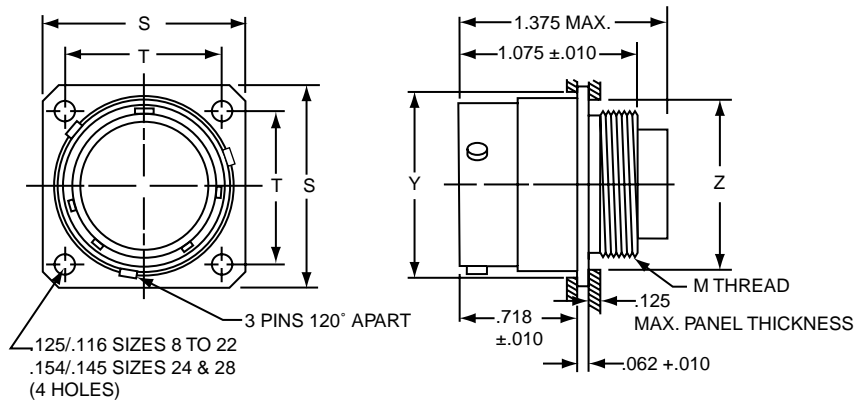

| Shell Size | M Cable Support Thread | R Coupling Thread | S Flange Width ±.005 | T Mounting Hole Centers ±.005 | Y Back Mount Min. Hole | Z Front Mount Min. Hole |
|------------|------------------------|-------------------|----------------------|-------------------------------|------------------------|-------------------------|
| 08         | NA                     | NA                | NA                   | NA                            | NA                     | NA                      |
| 10         | NA                     | NA                | NA                   | NA                            | NA                     | NA                      |
| 12**       | .733-36                | .875-20           | 1.031                | .812                          | .913                   | .760                    |
| 14         | .803-36                | .937-20           | 1.125                | .906                          | .980                   | .822                    |
| 16         | .930-36                | 1.062-18          | 1.250                | .969                          | 1.107                  | .948                    |
| 18         | 1.036-36               | 1.187-18          | 1.343                | 1.062                         | 1.209                  | 1.072                   |
| 20         | NA                     | NA                | NA                   | NA                            | NA                     | NA                      |
| 22         | 1.286-36               | 1.437-18          | 1.562                | 1.250                         | 1.452                  | 1.322                   |
| 24**       | 1.411-36               | 1.562-18          | 1.703                | 1.375                         | 1.577                  | 1.422                   |
| 28**       | 1.661-36               | 1.812-16          | 2.000                | 1.562                         | 1.827                  | 1.700                   |

NA designates not available. \*\* Available in Threaded Coupling only.  
All dimensions for reference only.

# MS27614, Pyle® FPK or FYL, Firewall Class K Single Hole (D-Hole) Mounted Receptacle



## Threaded or Bayonet

### Part #

\*To complete see how to order pages 218

### Military

| Shell Style | Service Class | Shell Size | Coupling Type | Insert Arrangement | Contact Type | Alternate Keying | Cable Support |
|-------------|---------------|------------|---------------|--------------------|--------------|------------------|---------------|
| MS27614     | K             | XX         | B or T        | XX                 | X            | X                | X             |

### Commercial

| Connector Type | Shell Style | Shell Size | Insert Arrangement | Contact Type | Contact Style | Alternate Keying | Cable Support | Deviations/ Specials |
|----------------|-------------|------------|--------------------|--------------|---------------|------------------|---------------|----------------------|
| FPK or FYL     | 19          | X          | XX                 | XX           | X             | X                | X             | XXX                  |

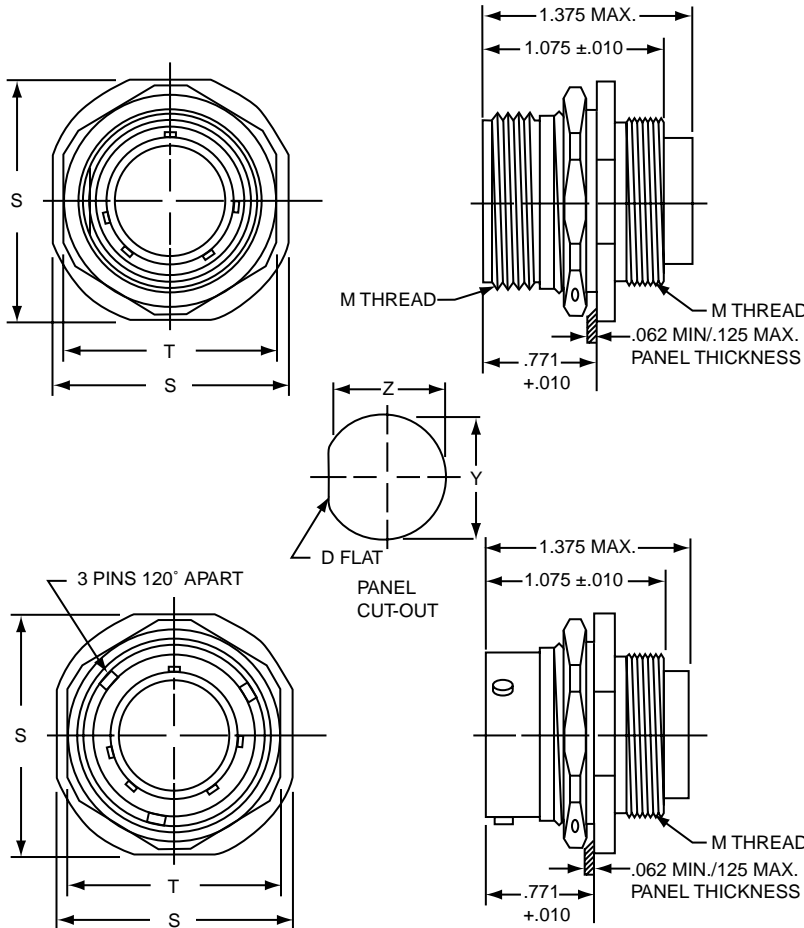

**THREADED COUPLING**  
Class K Stainless Steel  
Pyle FPK-19XX Series  
MS27614KXXTXX  
Military Class K

**BAYONET COUPLING**  
Class K Stainless Steel  
Pyle FYL-19XX Series  
MS27614KXXBXX  
Military Class K

| Shell Size | M Cable Support Thread | R Coupling Thread | S Flange Width | T Lock Nut Flats | Y Mounting Hole Dia. | Z Mounting Hole Flat | Recom. min. Torque Jam Nut |
|------------|------------------------|-------------------|----------------|------------------|----------------------|----------------------|----------------------------|
| 08         | NA                     | NA                | NA             | NA               | NA                   | NA                   | 33                         |
| 10         | NA                     | NA                | NA             | NA               | NA                   | NA                   | 36                         |
| 12**       | .733-36                | .875-20           | 1.291          | 1.215            | .947                 | .917                 | 56                         |
| 14         | .803-36                | .937-20           | 1.391          | 1.062            | 1.010                | .980                 | 65                         |
| 16         | .930-36                | 1.062-18          | 1.516          | 1.187            | 1.135                | 1.105                | 69                         |
| 18         | 1.036-36               | 1.187-18          | 1.614          | 1.312            | 1.260                | 1.225                | 81                         |
| 20         | NA                     | NA                | NA             | NA               | NA                   | NA                   | 100                        |
| 22**       | 1.286-36               | 1.437-18          | 1.954          | 1.562            | 1.510                | 1.475                | 123                        |
| 24         | NA                     | NA                | NA             | NA               | NA                   | NA                   | 133                        |
| 28         | NA                     | NA                | NA             | NA               | NA                   | NA                   | NA                         |

NA designates not available. \*\* Available in Threaded Coupling only.  
All dimensions for reference only.

38999  
SJT  
26482  
Matrix 2  
83723 III  
Pyle  
5015  
Crimp Rear  
Release Matrix  
26500 Pyle  
Printed  
Circuit Board  
EMI Filter  
Transient  
Fiber Optics  
High Speed  
Contacts  
Options  
Others

38999  
SJT I II III

26482  
Matrix 2

83723 III  
Matrix Pyle

5015  
Crimp Rear  
Release Matrix

26500 Pyle

Printed  
Circuit Board

EMI Filter  
Transient

Fiber Optics

High Speed  
Contacts

Options  
Others

**Part #**

**Military**

To complete see how to order pages 218

| Shell Style | Service Class | Shell Size | Coupling Type | Insert Arrangement | Contact Type | Alternate Keying | Cable Support |
|-------------|---------------|------------|---------------|--------------------|--------------|------------------|---------------|
| MS27615     | K             | XX         | B or S        | XX                 | X            | X                | X             |

**Commercial**

| Connector Type | Shell Style | Shell Style | Insert Arrangement | Contact Type | Contact Style | Alternate Keying | Cable Support | Deviations/Specials |
|----------------|-------------|-------------|--------------------|--------------|---------------|------------------|---------------|---------------------|
| FPK or FYL     | 11 or 12    | X           | XX                 | XX           | X             | X                | X             | XXX                 |

**THREADED COUPLING**  
Class K Stainless Steel  
Pyle FPK-11XX Series  
MS27615KXXTXX  
Military Class K

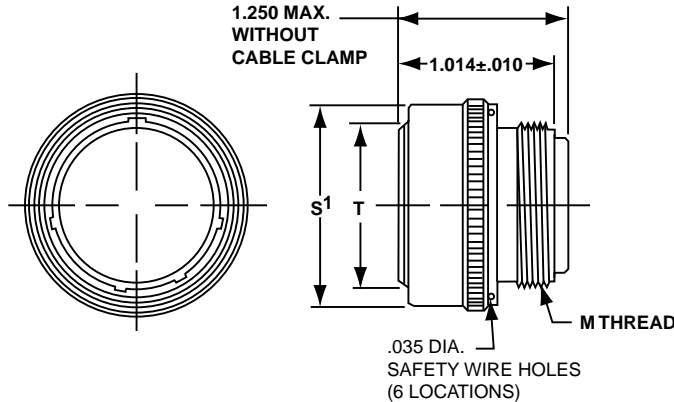

| Shell Size | M Cable Support Thread | R Coupling Thread | Coupling Nut        |                     | T Shell Dia. |
|------------|------------------------|-------------------|---------------------|---------------------|--------------|
|            |                        |                   | S <sup>1</sup> Dia. | S <sup>2</sup> Dia. |              |
| 08         | NA                     | NA                | NA                  | NA                  | NA           |
| 10         | NA                     | NA                | NA                  | NA                  | NA           |
| 12         | .733-36                | .875-20           | .984                | 1.018               | .696         |
| 14         | .803-36                | .937-20           | 1.054               | 1.087               | .765         |
| 16         | .930-36                | 1.062-18          | 1.181               | 1.214               | .892         |
| 18         | 1.036-36               | 1.187-18          | 1.287               | 1.320               | .998         |
| 20         | NA                     | NA                | NA                  | NA                  | NA           |
| 22         | 1.286-36               | 1.437-18          | 1.537               | 1.570               | 1.248        |
| 24         | 1.411-36               | 1.562-18          | 1.662               | 1.695               | 1.373        |
| 28**       | 1.661-36               | 1.812-16          | 1.912               | NA                  | 1.623        |

\*\* Available in Threaded Coupling only.

**BAYONET COUPLING** Class K Stainless Steel  
Pyle FYL-11XX Series MS27615KXXBXX  
Military Class K

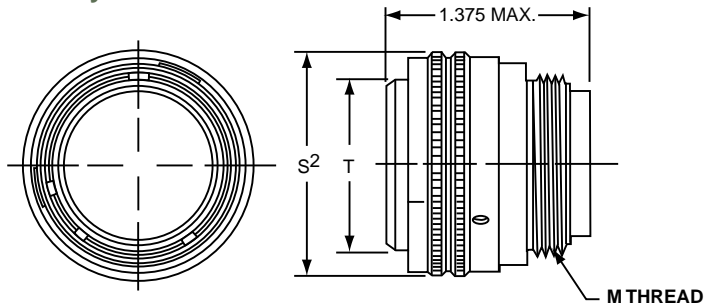

**MS27615, Pyle® FPK, Firewall Class K**

**Ratchet Lock Plug, Threaded**

**RATCHET LOCK PLUG**

Threaded Coupling  
Class K Stainless Steel Pyle FPK-12XX Series  
MS27615KXXSXX  
Military Class K

| Shell Size | M Cable Support Thread | R Coupling Thread | S Coupling Nut Dia | T Shell Dia. |
|------------|------------------------|-------------------|--------------------|--------------|
| 08         | NA                     | NA                | NA                 | NA           |
| 10         | .563-36                | .687-24           | .931               | .526         |
| 12         | .733-36                | .875-20           | 1.111              | .696         |
| 14         | .803-36                | .937-20           | 1.175              | .765         |
| 16         | .930-36                | 1.062-18          | 1.302              | .892         |
| 18         | 1.036-36               | 1.187-18          | 1.408              | .998         |
| 20         | NA                     | NA                | NA                 | NA           |
| 22         | 1.286-36               | 1.437-18          | 1.658              | 1.248        |
| 24         | 1.411-36               | 1.562-18          | 1.783              | 1.373        |
| 28         | 1.661-36               | 1.812-16          | 2.038              | 1.623        |

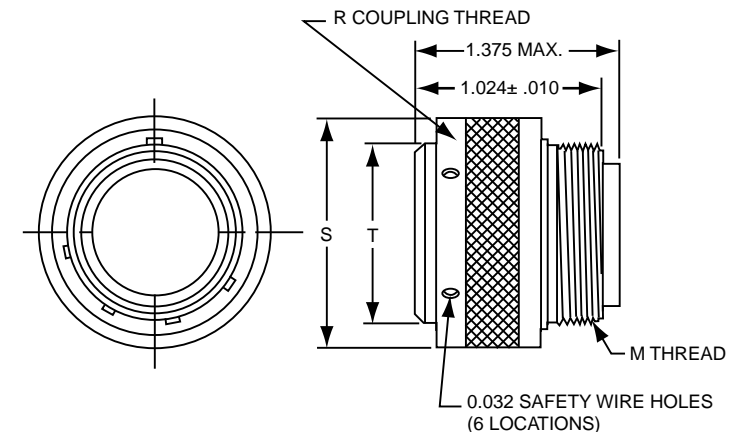

NA designates not available.  
All dimensions for reference only.

# MIL-DTL-26500 Type – 48 Series

## Receptacle Short Skirt



### Receptacle Short Skirt – Aluminum – Bayonet Coupling

Shorter, lighter, and more economical than the standard MIL-DTL-26500 connector receptacles, the 48 Series receptacle short skirt comes in two versions: with standard flange and with reduced flange. Both versions are 1.100" long which is .275" shorter than the length of the standard MIL-DTL-26500 connector.

They have molded epoxy fiberglass inserts and can operate continuously up to 125°C (257°F), but otherwise they offer the same environmental sealing, from the panel out, as standard MIL-DTL-26500 connectors. They have bayonet coupling and mate with standard MIL-DTL-26500 plugs. The hard dielectric inserts, with resilient face seal and molded-in gold plated solder cup pin type contacts, are available in insert arrangements shown in the chart below.

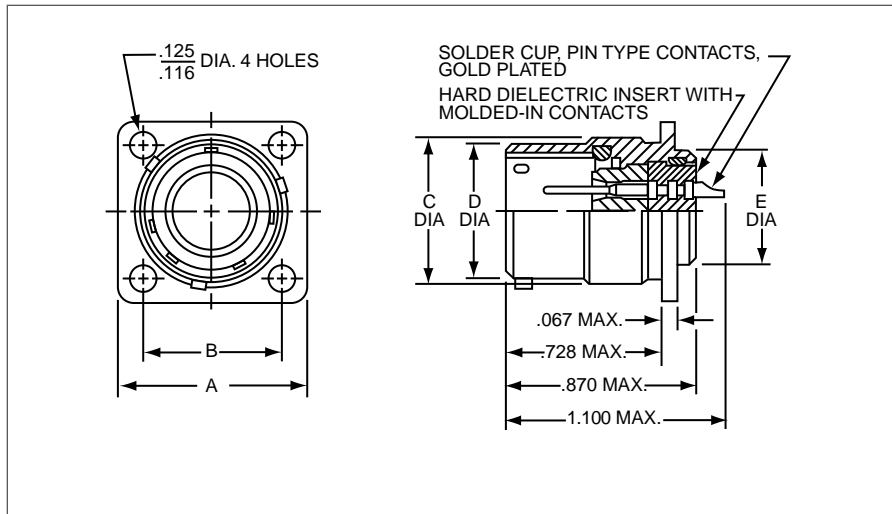

AVAILABLE WITH PIN CONTACTS ONLY

## 48 Series

### Receptacle Short Skirt with Standard Flange

| Insert Arrangement | Amphenol Part Number* | A ±.005 | B ±.005 | C Max. | D +.000 - .005 | E Max. |
|--------------------|-----------------------|---------|---------|--------|----------------|--------|
| 10-5               | 48-7115-XX            | .937    | .719    | .696   | .659           | .562   |
| 12-3               | 48-7116-XX            | 1.031   | .812    | .875   | .829           | .750   |
| 12-12              | 48-7117-XX            | 1.031   | .812    | .875   | .829           | .750   |
| 14-4               | 48-7118-XX            | 1.125   | .906    | .935   | .898           | .812   |
| 14-7               | 48-7119-XX            | 1.125   | .906    | .935   | .898           | .812   |
| 14-15              | 48-7120-XX            | 1.125   | .906    | .935   | .898           | .812   |
| 16-24              | 48-7121-XX            | 1.250   | .969    | 1.062  | 1.025          | .938   |
| 18-8               | 48-7122-XX            | 1.343   | 1.062   | 1.187  | 1.131          | 1.062  |
| 18-14              | 48-7123-XX            | 1.343   | 1.062   | 1.187  | 1.131          | 1.062  |
| 18-31              | 48-7124-XX            | 1.343   | 1.062   | 1.187  | 1.131          | 1.062  |
| 20-25              | 48-7251-XX            | 1.437   | 1.156   | 1.312  | 1.256          | 1.182  |
| 20-28              | 48-7175-XX            | 1.437   | 1.156   | 1.312  | 1.256          | 1.182  |
| 22-12              | 48-7125-XX            | 1.562   | 1.250   | 1.437  | 1.381          | 1.312  |
| 22-19              | 48-7126-XX            | 1.562   | 1.250   | 1.437  | 1.381          | 1.312  |
| 22-55              | 48-7127-XX            | 1.562   | 1.250   | 1.437  | 1.381          | 1.312  |

### Receptacle Short Skirt with Reduced Flange

| Insert Arrangement | Amphenol Part Number* | A Max. | B ±.005 | C Max. | D +.000 - .005 | E Max. |
|--------------------|-----------------------|--------|---------|--------|----------------|--------|
| 10-5               | 48-7132-XX            | .870   | .647    | .696   | .659           | .562   |
| 12-3               | 48-7133-XX            | .996   | .773    | .875   | .829           | .750   |
| 12-12              | 48-7134-XX            | .996   | .773    | .875   | .829           | .750   |

\* To complete part number: Replace XX with alternate keying positions (omit for normal position). See page 204.

For more information on other Amphenol®/Pyle® 48 Series products consult Amphenol, Sidney NY

III  
II  
I  
SJT  
38999

Matrix 2  
26482

Matrix  
Pyle  
83723 III

Release Matrix  
Crimp Rear  
5015

26500 Pyle

Printed  
Circuit Board

EMI Filter  
Transient

Fiber Optics

High Speed  
Contacts

Options  
Others

38999  
SJT I II III

26482  
Matrix 2

83723 III  
Matrix Pyle

5015  
Crimp Rear Release Matrix

26500 Pyle

Printed Circuit Board

EMI Filter Transient

Fiber Optics

High Speed Contacts

Options Others

### Special Application Wire Splice Connector

The Amphenol® 48 Series Wire Splice Connector is a low cost, space-saving connector design that can be used for various applications. The push-mating/twist-pull-unmating feature provides a simple solution to many design requirements without sacrificing performance. This wire splice connector utilizes a metal retention clip for a single size 16 pin and socket contact.

Features and benefits include:

- Push-mating/twist-pull-unmating
- Uses standard M39029/31-229 pin and M39029/32-248 socket contacts
- Incorporates environmental sealing grommet
- Metal collet retention
- Uses standard MIL-DTL-26500 contact removable tools
- Low cost
- Weight savings design
- Space savings design
- Color coded connector halves - red or blue

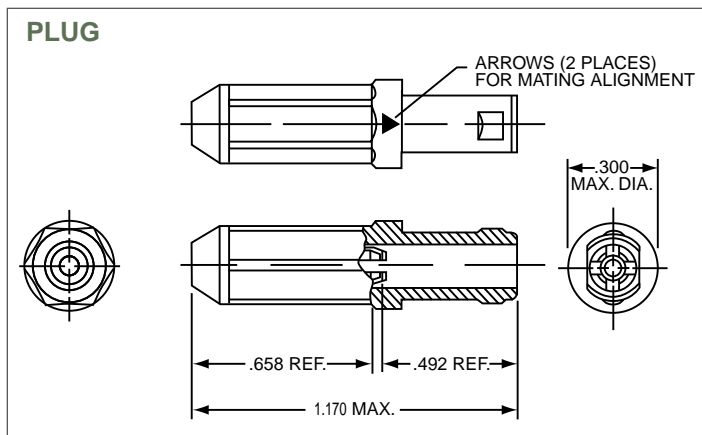
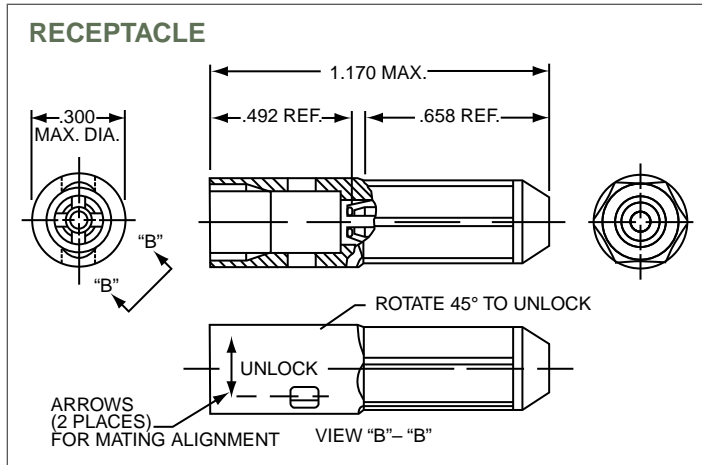
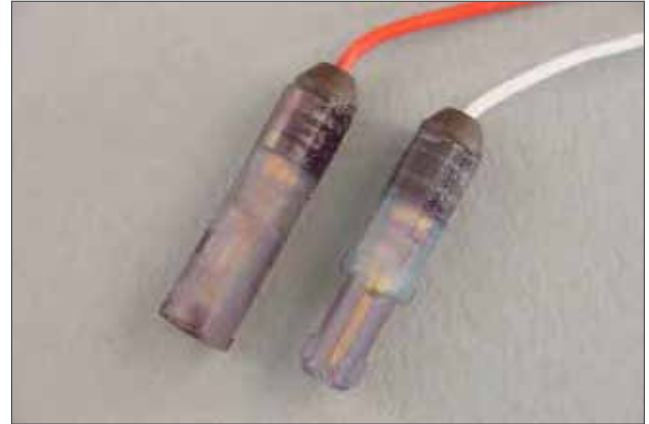

### Receptacle Wire Splice

| Amphenol 48 Series Part Number | Amphenol 10- Part Number | Color | Size 16 Contact Part Number |
|--------------------------------|--------------------------|-------|-----------------------------|
| 48-7191                        | 10-804342                | Blue  | Pin ZZL-4016-36LD           |
| 48-7191-1                      | 10-804342-1              | Red   | Socket ZZL-4116-36LD        |

### Plug Wire Splice

| Amphenol 48 Series Part Number | Amphenol 10- Part Number | Color | Size 16 Contact Part Number |
|--------------------------------|--------------------------|-------|-----------------------------|
| 48-7190                        | 10-804341                | Blue  | Pin ZZL-4016-36LD           |
| 48-7190-1                      | 10-804341-1              | Red   | Socket ZZL-4116-36LD        |



# Pyle® ZZL/ZZB, MIL-DTL-26500 Type Hermetic (three styles), Threaded or Bayonet



Amphenol®/Pyle® is an experienced supplier of highly reliable hermetic connectors for the aircraft industry. Amphenol's ZZL and ZZB series of hermetic receptacles are designed to the requirements of MIL-DTL-26500, they are available in stainless steel shells with gold-plated, nickel-iron alloy contacts.

Hermetic receptacles are available in shell sizes 8, 10, 12, 14, 16, 18, 22, 24 and 28. The hermetic series is offered in a variety of receptacle shell styles, which include solder mount, square flange and "D" hole mount. These connectors can be ordered with either eyelet, solder-well or printed circuit tail pin contacts.

Consult Amphenol, Sidney, NY for more information on hermetic connectors, and for optional connector designs.



III  
II  
I  
SJT  
38999

Matrix 2  
26482

Matrix  
Pyle  
83723 III

5015  
Crimp Rear  
Release Matrix

26500 Pyle

Printed  
Circuit Board

EMI Filter  
Transient

Fiber Optics

High Speed  
Contacts

Options  
Others

## Easy Steps to build a part number for Hermetic Connectors... Commercial

- 1.
- 2.
- 3.
- 4.
- 5.
- 6.
- 7.
- 8.
- 9.

| Series | Service Class | Shell Style | Shell Size | Insert Arrangement | Contact Type | Alternate Keying | Contact Plating | Variations |
|--------|---------------|-------------|------------|--------------------|--------------|------------------|-----------------|------------|
| ZZY    | A             | C           | T          | 55                 | P            | 6                | D               | H45        |

### Step 1. Select a Series

|     | Designates        |
|-----|-------------------|
| ZZL | Threaded Coupling |
| ZZB | Bayonet Coupling  |

### Step 2. Service Class

|    | Designates     |
|----|----------------|
| HC | Hermetic Class |

### Step 3. Select a Shell Style

|    | Designates                      |
|----|---------------------------------|
| 14 | Solder Mount Receptacle         |
| 15 | Single Hole Mounting Receptacle |
| 17 | Square Flange Receptacle        |

### Step 5. Select a Shell Size

|   |    |    |    |    |    |    |    |    |
|---|----|----|----|----|----|----|----|----|
| 8 | 10 | 12 | 14 | 16 | 18 | 22 | 24 | 28 |
|---|----|----|----|----|----|----|----|----|

### Step 6. Select an Insert Arrangement

See inserts labeled with an "H" on page 203 & 204

### Step 7. Select a Contact Type

|   | Designates                                 |
|---|--|
| P | Male Pin Contacts with standard gold plate |

### Step 8. Select an Alternate Keying Position

06, 07, 08, 09, 10 (Omit for Normal)  
See page 204

### Step 9. Select a Contact Plating

|   | Designates |
|---|------------|
| E | Eyelet     |
| W | Solderwell |

Consult Amphenol, Sidney, NY for ordering information of printed circuit tail contacts.

### Step 10. Select a Variation

|      | Designates  |
|------|---|
| H45  | 304L Stainless Steel Shell                                    |
| H52  | Tinned Termination Tails                                      |
| H56  | Same as standard; gold contacts                               |
| H77  | 304L Stainless Steel Shell, Inconel Contacts                  |
| H127 | Same as H125 except 304L Stainless Steel Shell                |
| H146 | 303 Stainless Steel Shell, 100 Micro-inch Gold                |
| H152 | 304L Stainless Steel Shell with Individual Beads, Loose Seals |
| H177 | 303 Stainless Steel Shell, Loose Seals                        |
| H181 | Tin Plated Contacts   |

38999  
SJT I II III

26482  
Matrix 2

83723 III  
Matrix Pyle

5015  
Crimp Rear  
Release Matrix

26500 Pyle

Printed  
Circuit Board

EMI Filter  
Transient

Fiber Optics

High Speed  
Contacts

Options  
Others

### Crimp Contacts per MIL-DTL-39029 – Copper Alloy, Gold Plating

| PIN CONTACTS |              |          |             |                   |
|--------------|--------------|----------|-------------|-------------------|
| Contact Size | Spec. Number | Bin Code | MS Number   | Amphenol/Pyle No. |
| 20           | M39029/31    | 241      | MS24254-20P | ZZL-4020-36LD*    |
| 16           | M39029/31    | 229      | MS24254-16P | ZZL-4016-36LD*    |
| 12           | M39029/31    | 235      | MS24254-12P | ZZL-4012-36LD*    |

| SOCKET CONTACTS |              |          |             |                   |
|-----------------|--------------|----------|-------------|-------------------|
| Contact Size    | Spec. Number | Bin Code | MS Number   | Amphenol/Pyle No. |
| 20              | M39029/32    | 260      | MS24255-20S | ZZL-4120-36LD*    |
| 16              | M39029/32    | 248      | MS24255-16S | ZZL-4116-36LD*    |
| 12              | M39029/32    | 254      | MS24255-12S | ZZL-4112-36LD*    |

\* Add – H139 for Boeing Marking for Pin/Socket, Standard Plating.  
Add – H148 for Boeing Marking for Pin/Socket, Select Plate.

### Amphenol®/Pyle® Special Application Contacts

| Copper Alloy, Rhodium plated Contacts† |                                 |                       |                          |
|--|---------------------------------|-----------------------|--------------------------|
| Contact Size                           | Description                     | Amphenol/Pyle Pin No. | Amphenol/Pyle Socket No. |
| 20                                     | Copper Alloy/<br>Rhodium plated | ZZL-4020-36LT         | ZZL-4120-36LT            |
| 16                                     | Copper Alloy/<br>Rhodium plated | ZZL-4016-36LT         | ZZL-4116-36LT            |
| 12                                     | Copper Alloy/<br>Rhodium plated | ZZL-4012-36LT         | ZZL-4112-36LT            |

† Contacts qualified to Boeing BACC47CN/CP.

| Thermocouple Contacts |                                 |                       |                          |                     |            |
|-----------------------|---------------------------------|-----------------------|--------------------------|---------------------|------------|
| Contact Size          | Material                        | Amphenol/Pyle Pin No. | Amphenol/Pyle Socket No. |                     |            |
|                       |                                 |                       | Pencil Clip Design*      | Split Tine Design** | Color Code |
| 20                    | Alumel<br>Chromel<br>Constantan | ZZL-4020-10R          | ZZL-4120-10R             | ZZY-4120-10R        | Green      |
|                       |                                 | ZZL-4020-10P          | ZZL-4120-10P             | ZZY-4120-10P        | White      |
|                       |                                 | ZZL-4020-10N          | ZZL-4120-10N             | ZZY-4120-10N        | Yellow     |
| 16                    | Alumel<br>Chromel<br>Constantan | ZZL-4016-10R          | ZZL-4116-10R             | ZZY-4116-10R        | Green      |
|                       |                                 | ZZL-4016-10P          | ZZL-4116-10P             | ZZY-4116-10P        | White      |
|                       |                                 | ZZL-4016-10N          | ZZL-4116-10N             | ZZY-4116-10N        | Yellow     |
| 12                    | Alumel<br>Chromel<br>Constantan | ZZL-4012-10R          | ZZL-4112-10R             | ZZY-4112-10P        | Green      |
|                       |                                 | ZZL-4012-10P          | ZZL-4112-10P             | ZZY-4112-10P        | White      |
|                       |                                 | ZZL-4012-10N          | ZZL-4112-10N             | ZZY-4112-10N        | Yellow     |

\* Pencil clip socket design - see page 201 for description.

\*\* Split tine socket with napkin ring design - see page 201 for description.

### Printed Circuit Board/Wire-Wrap Contacts

A variety of different designs are available; please consult Amphenol, Sidney, NY for more information.

### Reel Contacts

2000 contacts per reel (gold or rhodium plated) are available. Consult Amphenol, Sidney, NY for more information.

### Sealing Plugs

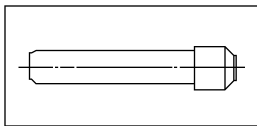

For sealing spare contact holes. Same sealing plug is used in both plug and receptacle.

| Contact Size     | Amphenol/Pyle No. | MS Number   | Color Code |
|------------------|-------------------|-------------|------------|
| 20               | 10-405996-20      | MS-27488-20 | Red        |
| 16               | 10-405996-16      | MS-27488-16 | Blue       |
| 12 & #1 Shielded | 10-405996-12      | MS-27488-12 | Yellow     |
| # 2 Shielded     | 10-405996-8       | MS27187-4   | White      |

### Sealing Gaskets

For use with square flange mounted receptacles. Provide waterproofing and pressure sealing features.

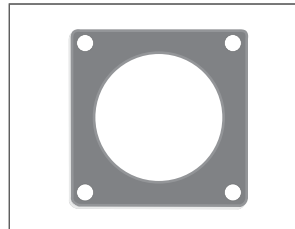

| Contact Size | Amphenol/Pyle No. |
|--------------|-------------------|
| 08           | ZZL-6508-10D      |
| 10           | ZZL-6510-10D      |
| 12           | ZZL-6512-10D      |
| 14           | ZZL-6514-10D      |
| 16           | ZZL-6516-10D      |
| 18           | ZZL-6518-10D      |
| 20           | ZZL-6520-10D      |
| 22           | ZZL-6522-10D      |
| 24           | NA                |

# Shielded/Coaxial Contacts

## For MIL-DTL-26500 Connectors



| Drawing<br>(See below<br>and on<br>next page) | Shielded<br>Contact Part No./<br>Contact Type              | Cable Stripping Dim.*** |       |       | Amphenol Crimp Tools<br>(Center Contact)                       |   |                    | Outer<br>Ferrule<br>Crimping<br>Tool†† | Cable Application   |
|---|--|-------------------------|-------|-------|--|---|--------------------|--|---|
|   |  | A                       | B     | C     | Tool   | Nest<br>Bushing   | Crimp<br>Setting   |  |   |
| <b>Type 1</b><br>#1 Shielded                  | 48-1226-02 Pin<br>48-1227-02 Socket<br>48-1227-50 Socket   | .2189                   | .0781 | .1094 | 294-268*<br>294-289**  | 294-1631  | #3                 | 294-529                                | #22 AWG per MIL-C-7078<br>Type II and MIL-C-27500-22<br>KING RG-174/U, -188/U                   |
|   | 48-1226-57 Pin<br>48-1227-57 Socket                        | .2189                   | .0781 | .1094 | 294-268*<br>294-289**  | 294-1631  | #1                 | 294-529                                | RG-161/U, -179/U, -179A/U, -187/U   |
|   | 48-1226-57 Pin<br>48-1227-57 Socket                        | .2189                   | .0781 | .1094 | 294-268*<br>294-289**  | 294-1631  | #1                 | 294-528                                | Raychem 9530A11   |
| <b>Type 2</b><br>#1 Shielded                  | 48-1226-51, -54 Pin<br>48-1227-51, -54, -56 Socket         | .2189                   | .0313 | .1563 | 294-268*<br>294-289**  | 294-1631  | #1                 | 294-528                                | RG-180/U, -180A/U, -180B/U, -195/U  |
| <b>Type 3</b><br>#1 Shielded                  | 48-1226-55 Pin<br>48-1227-55 Socket                        | .2344                   | .0313 | .1563 | 294-268*<br>294-289**  | 294-1631  | #1                 | 294-529                                | RG-178/U, -178A/U, -178B/U, -196-U  |
| <b>Type 4</b><br>#2 Shielded                  | 48-2187-02 Pin<br>48-2188-02 Socket                        | .2189                   | .1094 | .1406 | 294-126**<br>294-243**<br>294-1166**†<br>294-358**<br>294-268* | 294-1014<br>Turret Head<br>294-1014<br>294-1015<br>299-1630 | .030<br>-.040      | 294-528                                | #18, 20, 22 AWG per MIL-C-7078, Type II<br>and MIL-C-27500-18, -20, -22 KING<br>Extruded Jacket |
|   | 48-2187-50, -51 Pin<br>48-2188-50, -51, -53, -54<br>Socket | .2189                   | .1094 | .1406 | 294-1166**†<br>294-358**<br>294-268*                           | 294-1014<br>294-1015<br>294-1630                            | .030<br>.040<br>#3 | 294-528                                | RG-180/U, -180A/U, -180B/U, -195/U  |
| <b>Type 5</b><br>#2 Shielded                  | 48-2187-52 Pin<br>48-2188-52 Socket                        | .3125                   | .1094 | .1406 | 294-358**<br>294-268*  | 294-1015<br>294-1630  | -.037<br>-.041     | 294-530                                | RG-59/U and 21-541  |

\* Conforms to MIL-C-22520/2 specification.

\*\* MS3191 tools are inactive for new procurement, but can be used if available.

\*\*\* Refer to illustration on page 228.

† Same as 294-126, less positioners.

†† Including Hex Die Set

### Shielded Contact Assembly Procedure

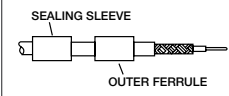
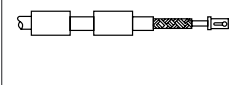
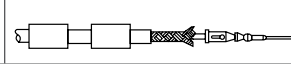
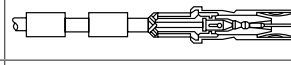
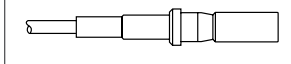
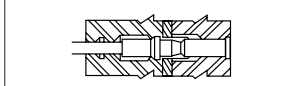
|        |   |   |
|--------|---|---|
| Step 1 | Slide sealing boot or sleeve and outer ferrule onto cable and strip cable as shown at right.<br>After stripping, slide spacer over center conductor as shown for <b>Type 2</b> and <b>Type 3</b> .<br>For <b>Type 3</b> slide spacer under wire braid.  |  |
| Step 2 | Insert stripped center conductor into contact until wire shows through inspection hole and dielectric ( <b>Type 1</b> , <b>Type 4</b> and <b>Type 5</b> ) or spacer ( <b>Type 2</b> and <b>Type 3</b> ) butts against contact. Fully seat contact in nest bushing of crimp tool and crimp in one full stroke. (Follow same crimping procedures except use nest bushing crimping tool from table above). |  |
| Step 3 | Slightly flair out ends of wire braid to facilitate insertion of inner ferrule of body assembly.<br>Do not comb braid.  |  |
| Step 4 | Install center contact in body assembly and slide inner ferrule underneath wire braid as shown. Push center contact until it is locked in place in the body assembly. Pull lightly on cable to make sure that contact is securely locked in place.  |  |
| Step 5 | Slide outer ferrule over braid and up against body as shown. There should be no slack in the wire braid. Crimp the outer ferrule with proper tool from table above. Then for <b>Type 1</b> , <b>Type 3</b> and <b>Type 5</b> slide sealing sleeve toward contact until sleeve touches outer ferrule.  |  |
| Step 6 | Insert the assembled shielded contact into the connector in the same way as the standard contact using applicable insertion tool (see page 28). This completes assembly for <b>Type 1</b> , <b>Type 2</b> , <b>Type 3</b> and <b>Type 5</b> .   |  |
| Step 7 | To complete assembly for <b>Type 4</b> , push sealing boot into connector grommet until O-ring riser of boot snaps into place and seals the assembly.   |   |

Type 1

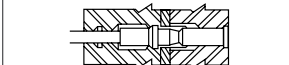
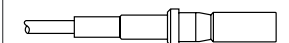
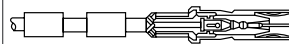
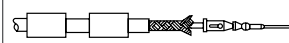
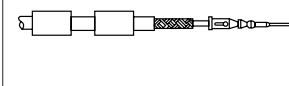
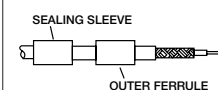
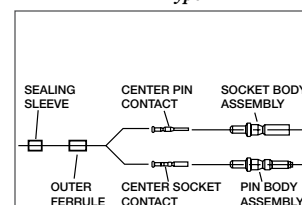

III  
II  
I  
SJT  
38999

Matrix 2  
26482

Matrix  
Pyle  
83723 III

Crimp Rear  
Release Matrix  
5015

26500 Pyle

Printed  
Circuit Board

EMI Filter  
Transient

Fiber Optics

High Speed  
Contacts

Options  
Others

38999  
SJT I II III

26482  
Matrix 2

83723 III  
Matrix Pyle

5015  
Crimp Rear  
Release Matrix

**Cable Stripping**

Strip cable jacket, braid and dielectric to the dimensions shown in the table on page 227. Make all cuts square and sharp, being careful not to nick braid, dielectric, or center conductor when cutting. If conductor ends fray, twist them to their normal lay.

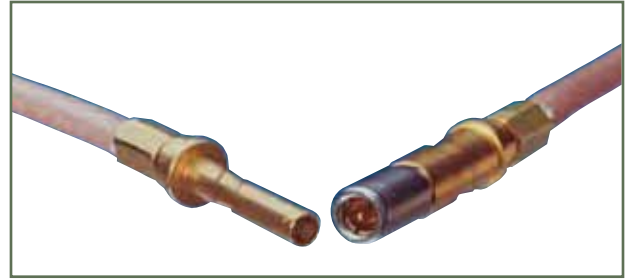
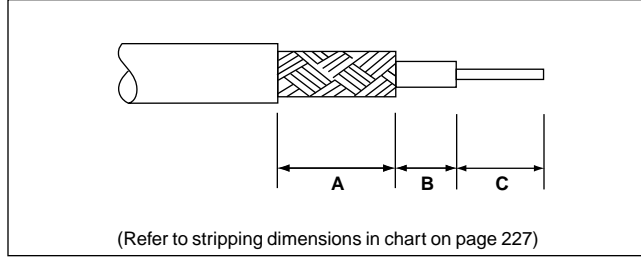

Shielded Contacts after Crimping

**Shielded Contact Assembly Procedure, cont.**

|  | Type 2 | Type 3 | Type 4 | Type 5 |
|--|--------|--------|--------|--------|
|  |        |        |        |        |
|  |        |        |        |        |
|  |        |        |        |        |
|  |        |        |        |        |
|  |        |        |        |        |
|  |        |        |        |        |
|  |        |        |        |        |
|  |        |        |        |        |
|  |        |        |        |        |

26500 Pyle

Printed  
Circuit Board

EMI Filter  
Transient

Fiber Optics

High Speed  
Contacts

Options  
Others

### Contact Termination

Contacts should be crimped to the wire with MS Standard hand crimping tools or specification automatic crimping machines.

When stripping the wire avoid nicking wires or damaging the insulation as it is a functional part of the sealing system.

| Contact Size | Wire Size | Stripping Length |
|--------------|-----------|------------------|
| 20           | 20 to 24  | .170" – .201"    |
| 16           | 16 to 18  | .207" – .238"    |
| 12           | 12 to 14  | .207" – .238"    |

Follow steps 1 – 4, as shown below, for proper contact crimping:

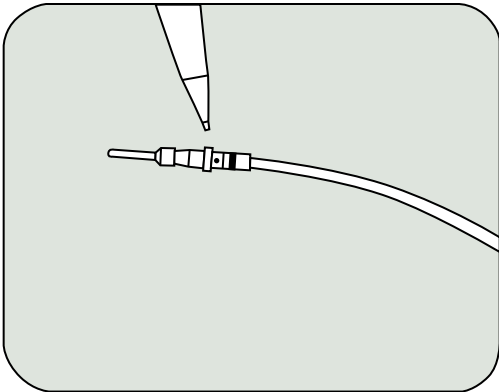

1. Insert stripped wire into contact pocket until it is visible through inspection hole.

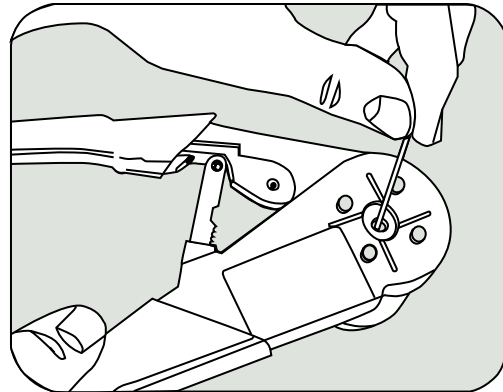

2. Carefully seat contact in crimp tool positioner.

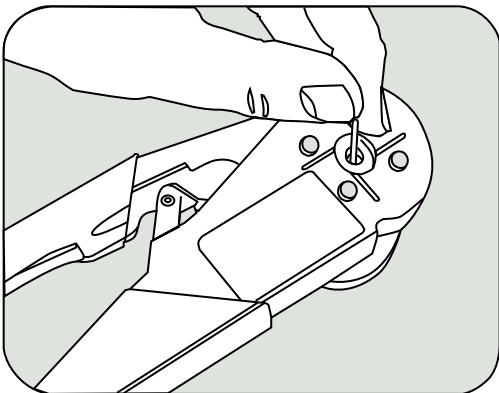

3. Crimp in one full stroke. (The ratchet will not release jaws until tool has completed stroke).

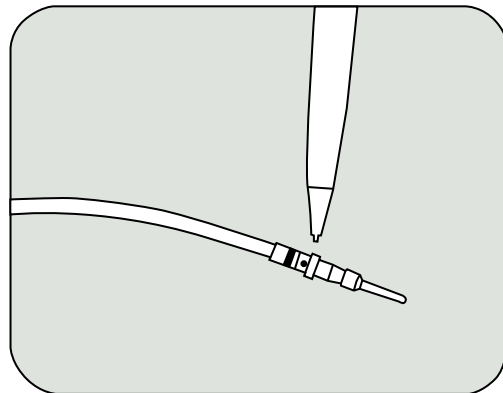

4. Inspect crimp for wire visibility through inspection hole.

38999  
SJT I II III

26482  
Matrix 2

83723 III  
Matrix Pyle

5015  
Crimp Rear  
Release Matrix

26500 Pyle

Printed  
Circuit Board

EMI Filter  
Transient

Fiber Optics

High Speed  
Contacts

Options  
Others

**Contact Insertion into the Connector**

The following steps are recommended for assembly.

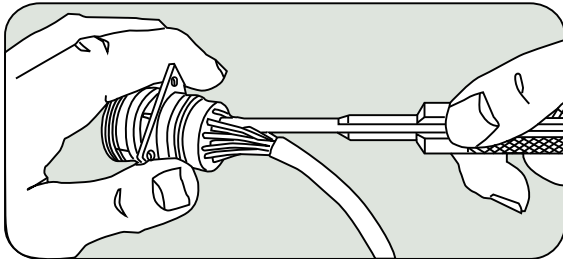
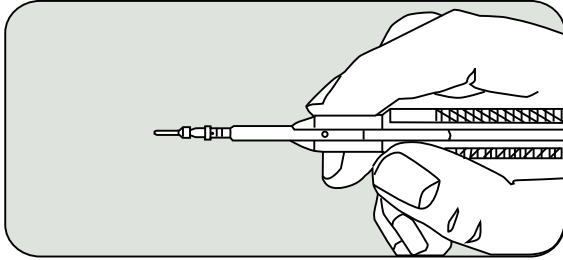

**NOTE:**

The Pyle Miniature Connector is designed with a unique sealing principle. Assembly of contacts into the connector must be made with reasonable care to avoid damage to the silicone rubber insert.

1. Lubricate wire cavities in back face of insert with a very thin film of DC-200 Silicone Oil or equal before inserting contacts.
2. Locate contact in insertion tool (as shown in illustration).
3. Align contact with hole in rear face of insert. The alignment of insertion tool with contact must be coaxial with the axis of the connector. When contact has entered rear seal portion of insert, maintain alignment of contact and tool parallel to, and in line with hole. Insert contact to full depth. Seating of the contact in the retention collet is audible. The contact insertion force is less than five pounds.
4. Extract insertion tool, keeping it aligned with hole.

**Contact Removal from the Connector**

A contact is removed from the connector insert with the extraction tool as follows:

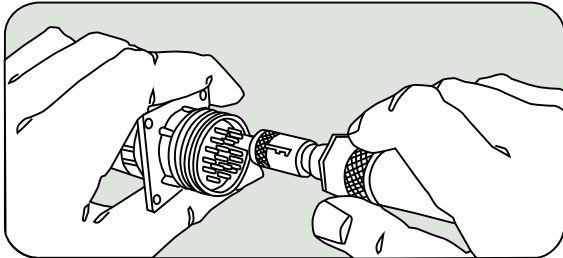
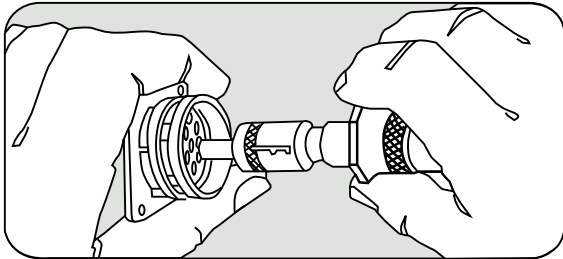

1. Set the spacer sleeve in the proper position for removal of male or female contact.
2. Place tool over the contact and insert into front face of cavity. The alignment of removal tool with contact must be coaxial with axis of connector.
3. Exert a nominal force axially (from 5 to 10 lbs.) to release retention collet. Spacer sleeve will shoulder at front face of insulation when tool is inserted to proper depth.
4. Push extraction plunger to force the contact out of the rear of the insert.
5. Grasp contact or wire at rear face of insert and complete the extraction.
6. Remove extraction tool axially.
7. After using extraction tool the spacer sleeve should be set forward in last notch to protect the end of the plunger guide.

**Panel Mounting**

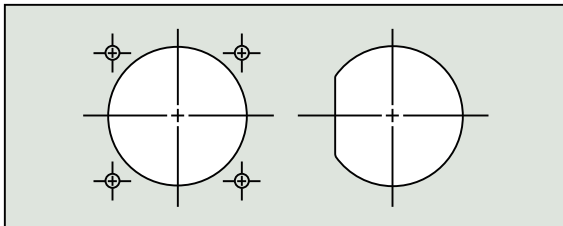

Two receptacle shell styles, flange mount and D-hole mount, are available for panel mounting. See the applicable drawings for mounting hole dimensions. The square flange receptacle, sizes 10 through 22, is fastened to the panel with four size #4-40 machine screws. The 24 and 28 size shells are fastened with #6-32 machine screws.



### Contact Insertion Tools



| Contact Size | Insertion Tool        |                  |            | Insertion Tool Replacement Tip & Pin |          |
|--------------|-----------------------|------------------|------------|--------------------------------------|----------|
|              | Amphenol/<br>Pyle No. | Mil. No.         | Color Code | Amphenol/<br>Pyle No.                | Mil. No. |
| 20           | ZZL-R-9510-A-20       | MIL-I-81969/17-9 | Red        | ZZL-R-9531-A-20                      | –        |
| 16           | ZZL-R-9510-16         | MIL-I-81969/17-4 | Blue       | ZZL-R-9531-16                        | –        |
| 12           | ZZL-R-9510-12         | MIL-I-81969/17-5 | Yellow     | ZZL-R-9531-12                        | –        |

### Contact Removal Tools



| Contact Size | Removal Tool          |               |            | Removal Tool Replacement Tip |          |
|--------------|-----------------------|---------------|------------|------------------------------|----------|
|              | Amphenol/<br>Pyle No. | Mil. No.      | Color Code | Amphenol/<br>Pyle No.        | Mil. No. |
| 20           | ZZL-R-9511-20         | MS-24256-R-20 | Red        | ZZL-R-9557-20                | –        |
| 16           | ZZL-R-9511-16         | MS-24256-R-16 | Blue       | ZZL-R-9557-16                | –        |
| 12           | ZZL-R-9511-12         | MS-24256-R-12 | Yellow     | ZZL-R-9557-12                | –        |

### Contact Crimping Tools



| Contact Size | Crimping Tool with Indenters |                          | Adjustable Turret     |                          | Checking Gage for Crimping Tool |          |
|--------------|------------------------------|--------------------------|-----------------------|--------------------------|---------------------------------|----------|
|              | Amphenol/<br>Pyle No.        | Mil. No.                 | Amphenol/<br>Pyle No. | Mil. No.                 | Amphenol/<br>Pyle No.           | Mil. No. |
| 20           | TP-201354                    | M22520/1-01<br>(Class 1) | TP-201355             | M22520/1-02<br>(Class 1) | TP-201356                       | M22520/3 |
| 16           |                              |                          |                       |                          |                                 |          |
| 12           |                              |                          |                       |                          |                                 |          |

### Contact Termination

Use table below to determine correct wire stripping length for your wire sizes. When stripping the wire, avoid nicking wires or damaging insulation, as it is a functional part of the sealing system.

| Contact Size | Wire Size | Stripping Length |
|--------------|-----------|------------------|
| 20           | 20 to 24  | .170" – .201"    |
| 16           | 16 to 18  | .207" – .238"    |
| 12           | 12 to 14  | .207" – .238"    |

See pages 229 and 300 for assembly instructions for proper contact termination and contact insertion/removal.

38999  
III  
II  
I  
SJT

26482  
Matrix 2

83723 III  
Matrix  
Pyle

5015  
Crimp Rear  
Release Matrix

26500 Pyle

Printed  
Circuit Board

EMI Filter  
Transient

Fiber Optics

High Speed  
Contacts

Options  
Others

38999  
SJT I II III

**Crimping Tools for Shielded Contacts**

**Amphenol Tool 357-100**



**Amphenol Tool 294-529 or 294-528**



| Shielded Contact Size | For Crimping Center Contact |                    | For Crimping Outer Ferrule           |               |
|-----------------------|-----------------------------|--------------------|--------------------------------------|---------------|
|                       | Basic Crimp Tool            | Contact Positioner | Basic Crimp Tool (Hex dies included) | Hex Dimension |
| # 1 Shielded          | 357-100                     | 294-1631           | 294-529                              | .128 Hex      |
| # 2 Shielded          |                             | 294-1630           | 294-528                              | .160 Hex      |

26482  
Matrix 2

83723 III  
Matrix Pyle

5015  
Crimp Rear Release Matrix

**Contact Insertion Tools**



| Contact Size      | Amphenol Part No. | Military Part No. |
|-------------------|-------------------|-------------------|
| 20                | 294-88            | MS2456A20         |
| 16                | 294-96            | MS2456A16         |
| #12, # 1 Shielded | 294-72            | MS24256R12        |
| #2 Shielded       | 294-128           | –                 |

26500 Pyle

Printed  
Circuit Board

**Contact Removal Tools**



| Contact Size      | Amphenol Part No. | Military Part No. |
|-------------------|-------------------|-------------------|
| 20                | 294-89            | MS2456R20         |
| 16                | 294-97            | MS2456R16         |
| #12, # 1 Shielded | 294-73            | MS2456R12         |
| #2 Shielded       | 294-127           | –                 |

EMI Filter  
Transient

Fiber Optics

**Standard Crimping Tool for Power Contacts**



| Basic Crimp Tool  |                   | Use with Turret Head |
|-------------------|-------------------|----------------------|
| Amphenol Part No. | Military Part No. |                      |
| 294-542           | M22520/1-01       | M22520/1-02          |

| Contact Size | Color Code | Wire Size |
|--------------|------------|-----------|
| 20           | Red        | 20–22–24  |
| 16           | Blue       | 16–18–20  |
| 12           | Yellow     | 12–14     |

For more information on other tools available consult Amphenol, Sidney, NY. NOTE: Amphenol and Pyle tools are interchangeable.

High Speed  
Contacts

Options  
Others

# Accessories - Cable Supports

## For MIL-DTL-26500 Connectors



### Cable Supports - Aluminum

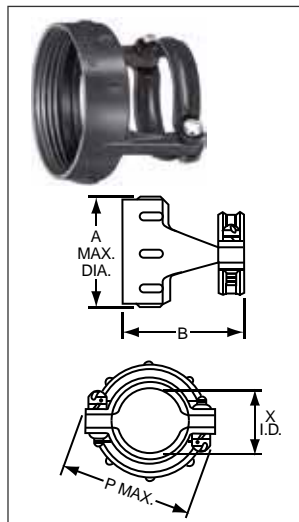

Cable clamps support cable or wire at the plug or receptacle and prevent twisting and pulling.

| Shell Size | Non-Conductive, Black Anodize Finish |                   | Conductive, Chromium Finish |                   | A Max. Dia. | B ±.015 | X I.D. ±.38 | Thread UNEF-2B | P Max. |
|------------|--------------------------------------|-------------------|-----------------------------|-------------------|-------------|---------|-------------|----------------|--------|
|            | MS No.                               | Amphenol/Pyle No. | MS No.                      | Amphenol/Pyle No. |             |         |             |                |        |
| 08         | *MS27291-13                          | *ZZL-R-5308-A     | *MS27291-701                | *ZZL-M-5308       | .582        | .935    | .180        | .4375-28       | .785   |
| 10         | *MS27291-1                           | *ZZL-R-5310-A     | *MS27291-101                | *ZZL-M-5310       | .731        | .935    | .270        | .5625-24       | .914   |
| 12         | MS27291-2                            | ZZL-R-5312-A      | *MS27291-201                | *ZZL-M-5312       | .919        | .935    | .400        | .7500-20       | 1.026  |
| 14         | MS27291-3                            | ZZL-R-5314-A      | *MS27291-301                | *ZZL-M-5314       | .981        | 1.170   | .460        | .8125-20       | 1.090  |
| 16         | MS27291-4                            | ZZL-R-5316-A      | MS27291-401                 | 10-804941-16E     | 1.106       | 1.170   | .610        | .9375-20       | 1.250  |
| 18         | *MS27291-5                           | *ZZL-R-5318-A     | *MS27291-501                | *ZZL-M-5318       | 1.231       | 1.170   | .690        | 1.0625-18      | 1.358  |
| 20         | *MS27291-14                          | *ZZL-R-5320-A     | *MS27291-801                | *ZZL-M-5320       | 1.356       | 1.170   | .830        | 1.1875-18      | 1.496  |
| 22         | *MS27291-6                           | *ZZL-R-5322-A     | *MS27291-601                | *ZZL-M-5322       | 1.481       | 1.170   | .940        | 1.3125-18      | 1.604  |
| 24         | MS27291-15                           | ZZL-R-5324-A      | *MS27291-901                | *ZZL-M-5324       | 1.606       | 1.170   | 1.040       | 1.4375-18      | 1.740  |

### Cable Supports - Stainless Steel, Straight



| Shell Size | Standard Straight Support (L = .781) |                   |        |            |                   |        | Long Straight Support |                   |        |                      |          |
|------------|--------------------------------------|-------------------|--------|------------|-------------------|--------|-----------------------|-------------------|--------|----------------------|----------|
|            | MS No.                               | Amphenol/Pyle No. | A Dia. | MS No.     | Amphenol/Pyle No. | A Dia. | Similar to MS No.     | Amphenol/Pyle No. | A Dia. | L Max Overall Length | Thread   |
| 10         | NA                                   | NA                | NA     | NA         | NA                | NA     | NA                    | *FPL-R-5310L      | NA     | NA                   | .563-36  |
| 12         | NA                                   | NA                | NA     | NA         | NA                | NA     | MS27658-12            | FPL-R-5312L       | .435   | 1.070                | .753-36  |
| 14         | MS27657-14                           | ZZL-R-5314        | .230   | MS27657-1  | FPL-R-5314        | .382   | MS27658-14            | FPL-R-5314L       | .504   | 1.170                | .803-36  |
| 16         | *MS27657-16                          | *ZZL-R-5316       | .292   | *MS27657-2 | *FPL-R-5316       | .462   | MS27658-16            | FPL-R-5316L       | .686   | 1.270                | .930-36  |
| 18         | MS27657-18                           | ZZL-R-5318        | .392   | MS27657-3  | FPL-R-5318        | .556   | *MS27658-18           | *FPL-R-5318L      | .794   | 1.370                | 1.036-36 |
| 20         | NA                                   | NA                | NA     | NA         | NA                | NA     | NA                    | *FPL-R-5320L      | NA     | NA                   | NA       |
| 22         | MS27657-22                           | ZZL-R-5322        | .516   | MS27657-4  | FPL-R-5322        | .608   | MS27658-22            | FPL-R-5322L       | 1.038  | 1.570                | 1.286-36 |
| 24         | NA                                   | NA                | NA     | NA         | NA                | NA     | MS27658-24            | FPL-R-5324L       | 1.162  | 1.670                | 1.411-36 |
| 28         | NA                                   | NA                | NA     | NA         | NA                | NA     | MS27658-28            | FPL-R-5328L       | 1.412  | 1.870                | 1.661-36 |

### Cable Supports - Stainless Steel, Right Angle



| Shell Size | Cable Support, Right Angle |                   |        |                      |          |
|------------|----------------------------|-------------------|--------|----------------------|----------|
|            | Similar to MS No.          | Amphenol/Pyle No. | A Dia. | L Max Overall Length | Thread   |
| 10         | NA                         | *FPL-R-5210       | NA     | NA                   | .563-36  |
| 12         | MS27659-12                 | FPL-R-5212        | .435   | 1.298                | .753-36  |
| 14         | MS27659-14                 | FPL-R-5214        | .504   | 1.388                | .803-36  |
| 16         | *MS27659-16                | *FPL-R-5216       | .686   | 1.523                | .930-36  |
| 18         | MS27659-18                 | FPL-R-5218        | .794   | 1.622                | 1.036-36 |
| 22         | MS27659-22                 | FPL-R-5222        | 1.038  | 1.878                | 1.286-36 |
| 24         | *MS27659-24                | *FPL-R-5224       | 1.162  | 2.000                | 1.411-36 |
| 28         | *MS27659-28                | *FPL-R-5228       | 1.412  | 2.250                | 1.661-36 |

\*Consult Amphenol, Sidney, NY for availability

38999  
III II I SJT

26482  
Matrix 2

83723 III  
Matrix Pyle

5015  
Crimp Rear Release Matrix

26500 Pyle

Printed  
Circuit Board

EMI Filter  
Transient

Fiber Optics

High Speed  
Contacts

Options  
Others

Additional right angle conduit adapters and cable support clamps are available which provide added protection for the cable or wiring. Closed back cable support clamps have a removable cover; while open back cable support clamps have a strap to protect the wires at the right angle bend.

### Cable Supports - Stainless Steel, Closed Right Angle

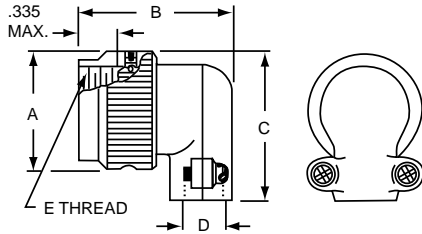

| Shell Size | Cable Support - Closed Right Angle |               |             |        |       |       |                  |
|------------|------------------------------------|---------------|-------------|--------|-------|-------|------------------|
|            | MS No.                             | Amphenol No.  | A Dia. Max. | B Max. | C Max | D Max | E Thread UNEF-2B |
| 8          | MS27558-1                          | 48-2222-08100 | .672        | 1.200  | .938  | .245  | .4375-28         |
| 10         | MS27558-2                          | 48-2222-10100 | .797        | 1.320  | 1.049 | .370  | .5625-24         |
| 12         | MS27558-3                          | 48-2222-12100 | 1.016       | 1.320  | 1.248 | .370  | .7500-20         |
| 14         | MS27558-4                          | 48-2222-14100 | 1.110       | 1.487  | 1.330 | .520  | .8125-20         |
| 16         | MS27558-5                          | 48-2222-16100 | 1.234       | 1.470  | 1.447 | .520  | .9375-20         |
| 18         | MS27558-6                          | 48-2222-18100 | 1.360       | 1.588  | 1.577 | .645  | 1.0625-18        |
| 20         | MS27558-7                          | 48-2222-20100 | 1.485       | 1.759  | 1.698 | .780  | 1.1875-18        |
| 22         | MS27558-8                          | 48-2222-22100 | 1.610       | 1.759  | 1.820 | .780  | 1.3125-18        |
| 24         | MS27558-9                          | 48-2222-24100 | 1.735       | 2.027  | 1.945 | 1.065 | 1.4375-18        |

### Cable Supports - Stainless Steel, Open Right Angle

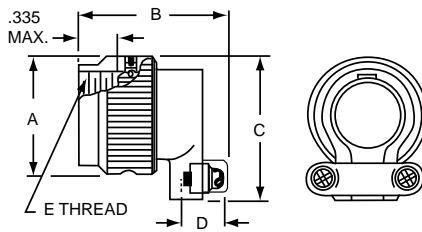

| Shell Size | Cable Support - Open Right Angle |               |             |        |       |       |                  |
|------------|----------------------------------|---------------|-------------|--------|-------|-------|------------------|
|            | MS No.                           | Amphenol No.  | A Dia. Max. | B Max. | C Max | D Max | E Thread UNEF-2B |
| 8          | MS27559-1                        | 48-2222-08200 | .672        | 1.173  | .938  | .201  | .4375-28         |
| 10         | MS27559-2                        | 48-2222-10200 | .797        | 1.293  | 1.049 | .328  | .5625-24         |
| 12         | MS27559-3                        | 48-2222-12200 | 1.016       | 1.293  | 1.248 | .328  | .7500-20         |
| 14         | MS27559-4                        | 48-2222-14200 | 1.110       | 1.460  | 1.330 | .452  | .8125-20         |
| 16         | MS27559-5                        | 48-2222-16200 | 1.234       | 1.443  | 1.447 | .508  | .9375-20         |
| 18         | MS27559-6                        | 48-2222-18200 | 1.360       | 1.561  | 1.577 | .571  | 1.0625-18        |
| 20         | MS27559-7                        | 48-2222-20200 | 1.485       | 1.732  | 1.698 | .748  | 1.1875-18        |
| 22         | MS27559-8                        | 48-2222-22200 | 1.610       | 1.732  | 1.819 | .748  | 1.3125-18        |
| 24         | MS27559-9                        | 48-2222-24200 | 1.735       | 2.000  | 1.945 | .996  | 1.4375-18        |

### Conduit Adapter- Stainless Steel, Right Angle

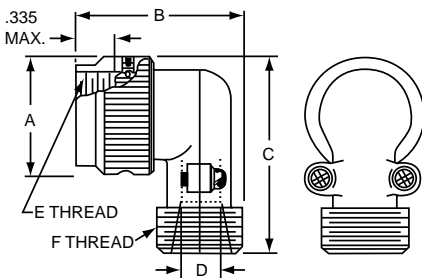

| Shell Size | Conduit Adapter - Right Angle |               |             |        |       |       |                  |                  |
|------------|-------------------------------|---------------|-------------|--------|-------|-------|------------------|------------------|
|            | Equivalent MS No.             | Amphenol No.  | A Dia. Max. | B Max. | C Max | D Max | E Thread UNEF-2B | F Thread UNEF-2A |
| 8          | MS27557-1                     | 48-2222-08000 | .672        | 1.300  | 1.403 | .245  | .4375-28         | .6250-24         |
| 10         | MS27557-2                     | 48-2222-10000 | .797        | 1.420  | 1.514 | .370  | .5625-24         | .7500-20         |
| 12         | MS27557-3                     | 48-2222-12000 | 1.016       | 1.420  | 1.713 | .370  | .7500-20         | .7500-20         |
| 14         | MS27557-4                     | 48-2222-14000 | 1.110       | 1.575  | 1.795 | .520  | .8125-20         | .8750-20         |
| 16         | MS27557-5                     | 48-2222-16000 | 1.234       | 1.558  | 1.912 | .520  | .9375-20         | .8750-20         |
| 18         | MS27557-6                     | 48-2222-18000 | 1.360       | 1.675  | 2.042 | .645  | 1.0625-18        | 1.0000-20        |
| 20         | MS27557-7                     | 48-2222-20000 | 1.485       | 1.863  | 2.163 | .780  | 1.1875-18        | 1.1875-18        |
| 22         | MS27557-8                     | 48-2222-22000 | 1.610       | 1.863  | 2.285 | .780  | 1.3125-18        | 1.1875-18        |
| 24         | MS27557-9                     | 48-2222-24000 | 1.735       | 2.118  | 2.410 | 1.065 | 1.4375-18        | 1.4375-18        |

38999  
SJT I II III

26482  
Matrix 2

83723 III  
Matrix Pyle

5015  
Crimp Rear Release Matrix

26500 Pyle

Printed  
Circuit Board

EMI Filter  
Transient

Fiber Optics

High Speed  
Contacts

Options  
Others

## Dummy Receptacles - Aluminum Threaded or Bayonet

Used as an anchoring place for disconnected plugs, dummy receptacles eliminate the problems involved in letting plugs swing freely. They also provide a limited air seal and prevent accumulation of foreign material on the face of the plug. Order by part numbers in chart below.

Threaded Style pictured

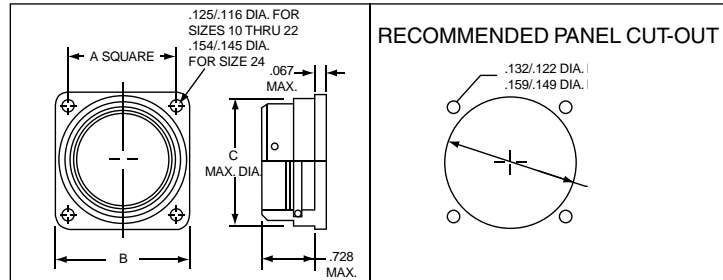

| Size | Dimensional Data       |                      |            |                   |                   | How to Order         |                           |                      |                           |
|------|------------------------|----------------------|------------|-------------------|-------------------|----------------------|---------------------------|----------------------|---------------------------|
|      | Thread Size<br>UNEF-2A | A<br>Square<br>±.005 | B<br>±.005 | C<br>Max.<br>Dia. | D<br>Min.<br>Dia. | Bayonet              |                           | Threaded             |                           |
|      |                        |                      |            |                   |                   | Amphenol<br>Part No. | Equivalent MS<br>Part No. | Amphenol<br>Part No. | Equivalent MS Part<br>No. |
| 10   | .6875-24               | .719                 | .937       | .696              | .748              | 48-149-10000         | MS27297-1                 | 48-172-10000         | MS27296-1                 |
| 12   | .8750-20               | .812                 | 1.031      | .875              | .913              | 48-149-12000         | MS27297-2                 | 48-172-12000         | MS27296-2                 |
| 14   | .9375-20               | .906                 | 1.125      | .935              | .980              | 48-149-14000         | MS27297-3                 | 48-172-14000         | MS27296-3                 |
| 16   | 1.0625-18              | .969                 | 1.250      | 1.062             | 1.107             | 48-149-16000         | MS27297-4                 | 48-172-16008         | MS27296-4                 |
| 18   | 1.1875-18              | 1.062                | 1.343      | 1.187             | 1.209             | 48-149-18000         | MS27297-5                 | 48-172-18000         | MS27296-5                 |
| 20   | 1.3125-18              | 1.156                | 1.437      | 1.312             | 1.337             | 48-149-20000         | MS27297-8                 | 48-172-20000         | MS27296-8                 |
| 22   | 1.4375-18              | 1.250                | 1.562      | 1.437             | 1.452             | 48-149-22000         | MS27297-6                 | 48-172-22000         | MS27296-6                 |
| 24   | 1.5625-18              | 1.375                | 1.703      | 1.562             | 1.577             | 48-149-24000         | MS27297-9                 | 48-172-24000         | MS27296-9                 |

## Protection Caps and Chains - Threaded or Bayonet

Protective metal caps provide an environmental seal for the connector face. They exclude dirt, dust, moisture and other foreign materials from the face of unmated plugs and receptacles. The caps have a woven steel strap so they can be easily attached

| Size | Dimensional Data  |                            |                          |                                 |                             |                                    |
|------|-------------------|----------------------------|--------------------------|---------------------------------|-----------------------------|------------------------------------|
|      | A<br>Max.<br>Dia. | B<br>±.250<br>Chain Length | Bayonet Cap              |                                 | Threaded Cap                |                                    |
|      |                   |                            | Plug<br>C +.000<br>-.005 | Receptacle<br>C' +.005<br>-.000 | Plug<br>C Thread<br>UNEF-2A | Receptacle<br>C' Thread<br>UNEF-2B |
| 10   | .906              | 3.00                       | .659                     | .662                            | .6875-24                    | .6875-24                           |
| 12   | 1.078             | 3.00                       | .829                     | .832                            | .8750-20                    | .8750-20                           |
| 14   | 1.141             | 5.00                       | .898                     | .901                            | .9375-20                    | .9375-20                           |
| 16   | 1.266             | 5.00                       | 1.025                    | 1.028                           | 1.0625-18                   | 1.0625-18                          |
| 18   | 1.375             | 5.00                       | 1.131                    | 1.134                           | 1.1875-18                   | 1.1875-18                          |
| 20   | 1.510             | 5.00                       | 1.256                    | 1.263                           | 1.3125-18                   | 1.3125-18                          |
| 22   | 1.625             | 5.00                       | 1.381                    | 1.384                           | 1.4375-18                   | 1.4375-18                          |
| 24   | 1.760             | 5.00                       | 1.506                    | 1.511                           | 1.5625-18                   | 1.5625-18                          |

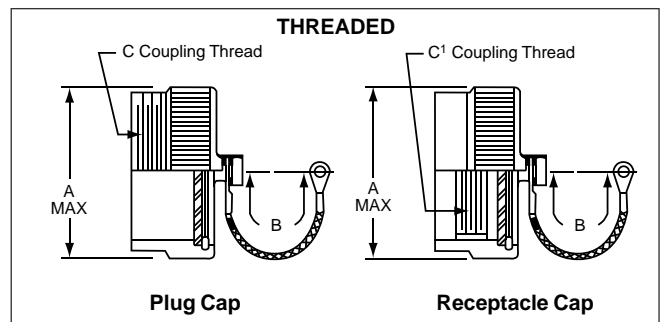
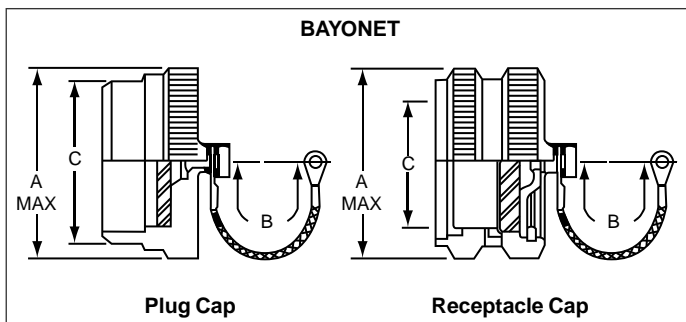

| How to Order Bayonet Cap & Chain |                      |                           |                      |                           |
|----------------------------------|----------------------|---------------------------|----------------------|---------------------------|
| Size                             | Plug                 |                           | Receptacle           |                           |
|                                  | Amphenol<br>Part No. | Equivalent MS<br>Part No. | Amphenol<br>Part No. | Equivalent MS<br>Part No. |
| 10                               | 48-2144              | MS27293-1                 | 48-2150              | MS27295-1                 |
| 12                               | 48-2143              | MS27293-2                 | 48-2149              | MS27295-2                 |
| 14                               | 48-2142              | MS27293-3                 | 48-2148              | MS27295-3                 |
| 16                               | 48-2141              | MS27293-4                 | 48-2147              | MS27295-4                 |
| 18                               | 48-2140              | MS27293-5                 | 48-2146              | MS27295-5                 |
| 20                               | 48-2773              | MS27293-8                 | 48-2774              | MS27295-8                 |
| 22                               | 48-2139              | MS27293-6                 | 48-2145              | MS27295-6                 |
| 24                               | 48-2767              | MS27293-9                 | 48-2768              | MS27295-9                 |

| How to Order Threaded Cap & Chain |                      |                           |                      |                           |
|-----------------------------------|----------------------|---------------------------|----------------------|---------------------------|
| Size                              | Plug                 |                           | Receptacle           |                           |
|                                   | Amphenol<br>Part No. | Equivalent MS<br>Part No. | Amphenol<br>Part No. | Equivalent MS<br>Part No. |
| 10                                | 48-2340-10           | MS27292-1                 | 48-2301-10           | MS27294-1                 |
| 12                                | 48-2340-12           | MS27292-2                 | 48-2301-12           | MS27294-2                 |
| 14                                | 48-2340-14           | MS27292-3                 | 48-2301-14           | MS27294-3                 |
| 16                                | 48-2340-16           | MS27292-4                 | 48-2301-16           | MS27294-4                 |
| 18                                | 48-2340-18           | MS27292-5                 | 48-2301-18           | MS27294-5                 |
| 20                                | 48-2340-20           | MS27292-8                 | 48-2301-20           | MS27294-8                 |
| 22                                | 48-2340-22           | MS27292-6                 | 48-2301-22           | MS27294-6                 |
| 24                                | 48-2340-24           | MS27292-9                 | 48-2301-24           | MS27294-9                 |

III  
II  
I  
SJT  
38999

Matrix 2  
26482

Matrix Pyle  
83723 III

Release Matrix  
5015  
Crimp Rear

26500 Pyle

Printed  
Circuit Board

EMI Filter  
Transient

Fiber Optics

High Speed  
Contacts

Options  
Others



# Amphenol Circular Connectors for Printed Circuit Board Applications



## TABLE OF CONTENTS

### Circular Connectors for Printed Circuit Board Applications

- Table of Contents . . . . . 236
- Introduction and Guide to Selecting a PCB Circular Connector . . . . . 237, 238
- Circular Connectors with PCB Contacts Insert Availability . . . . . 239
- Alternate Positioning for MIL-DTL-38999 Connectors. . . . . 240
- Circular Connectors – PCB Contacts Insert Arrangements . . . . . 241-255

### Shell Styles with PCB Contacts:

- MIL-DTL-38999 TV, Series III Shell Styles, Including Hermetic . . . . . 256-263
- MIL-DTL-38999 JT, Series II Shell Styles, Including Hermetic . . . . . 264-268
- MIL-DTL-38999 LJT, Series I Shell Styles, Including Hermetic . . . . . 269-275
- Stand-off Adapter for use with MIL-DTL-38999 PCB Connectors . . . . . 276



PCB Contacts



### PCB Connector Typical Markets:

- Military and Commercial Aviation
- Space & Satellites
- Military Vehicles
- Shipboard
- Instrumentation





# Amphenol® Circular Connectors for Printed Circuit Board Applications



Amphenol provides circular connectors with PC Tail contacts. This catalog section features the 38999 Series III, II, and I connectors which are ideal for printed circuit boards applications, either with rigid attachment or with flex print assembly attachment. For information on other amphenol circular connector with PC Tail contacts consult Amphenol, Sidney NY.

## MIL-DTL-38999 CONNECTORS, METAL & COMPOSITE

- Lightweight, compact, high density and high reliability cylindrical
- Operating voltage to 900 VAC (RMS) at sea level
- Environmentally resistant
- Solder or crimp rear release contacts in mating plug
- Series I (LJT) - Bayonet coupling
  - Scoop-proof (recessed pins) offers maximum contact protection
- Series II (JT) - Bayonet coupling
  - For applications requiring maximum weight/space savings and reliability
- Series III (Tri-Start) - Threaded, quick coupling in one complete turn
  - Designed for general duty as well as severe environmental applications
  - Superior EMI shielding with grounding fingers and metal-to-metal mating
  - Filter/Transient protection versions available
  - Scoop-proof contact protection
  - Stainless steel firewall versions, and composite versions
  - Available in Hermetics



Special 38999 Connector with Stand-off Shell and PC Tails

See MIL-DTL-38999 Series I, II, and III sections of this catalog for more detailed information.  
Note: MIL-DTL-38999 supersedes MIL-C-38999.

## How to Measure the PCB Tail Length

The tail length of the PCB is the portion of the contact that extends beyond the rear of the shell. This length will vary in relationship to the mounting flange, depending on the series of connector selected. Standard lengths are shown on the connector shell style drawings in this catalog. These shell style drawing pages also provide how to order part numbering for standard PCB cylindrical connectors. When computing the desired tail length, it is important to take into consideration the following factors:

- The connector series and shell style.
- The mounting style of the receptacle; jam nut (D hole) or panel mount (four holes). This can affect the overall length of the tail.
- The extension of the tail beyond the opposite side of the board or the flex.
- The space required to adequately clean flux from between the board or flex and the rear of the connector shell. Connectors that are mounted flush against the board may trap soldering flux which could lead to corrosion of the solder joints.

## Would Alignment Discs, Headers or Special Stand-off Shells be Beneficial?

The answer is yes, any mechanical methods needed to stabilize the board or flex to the connector and/or the panel is beneficial. The PCB tails shown in this catalog are of one diameter. Stepped tails or PCB tails with an increased diameter on a designated portion may be required for certain applications.

Alignment discs are available which provide ease of alignment of pins to boards, protection during shipment and optimized electrical circuit separation. Header assemblies (see pages 106 & 107) are available which provide time and cost saving potentials. Standoffs may be required for certain applications. Amphenol has developed a new stand-off adapter (see page 276) which may eliminate the need for special stand-off shell designs. Connectors with clinch nuts can be provided. Please call Amphenol to discuss any optional designs or any special requirements.



38999 Series III Box Mount Connector with PC Tails



38999 Series III Connector with a Special Configuration Composite Shell and PC Tails



Stand-off Adapter on a Jam Nut Receptacle.



Universal Header Assemblies are available for Flex Print/PC Board Mounting. Beneficial especially when electrical testing of the connector requires it to be removed and reattached.

38999  
III  
II  
I  
SJT

26482  
Matrix 2

83723 III  
Matrix  
Pyle

5015  
Crimp Rear  
Release Matrix

26500 Pyle

Printed  
Circuit Board

EMI Filter  
Transient

Fiber Optics

High Speed  
Contacts

Options  
Others

38999  
SJT I II III

26482  
Matrix 2

83723 III  
Matrix Pyle

5015  
Crimp Rear Release Matrix

26500 Pyle

Printed  
Circuit Board

EMI Filter  
Transient

Fiber Optics

High Speed  
Contacts

Options  
Others

**What Determines the Diameter of the PCB Tail?**

The outside diameter of the PCB tail is determined by the inside diameter of the plated through-hole on the board or flex print. The standard or most popular diameters are shown in the chart on the next page and are called out in the connector illustrations in this catalog.

**Standard diameters of PCB tails**

| Connector Series | Size 16 Contact | Size 20 Contact | Size 22D Contact |
|------------------|-----------------|-----------------|------------------|
| MIL-DTL-38999    | .062 ±.001      | .019 ±.001      | .019 ±.001       |

**Should PCB Tails be Gold Plated or Pre-tinned?**

The standard PCB tails for MIL-DTL-38999 receptacles have gold plating, .00005 inches over nickel. Amphenol can substitute a pre-tinned version of these tails to facilitate the termination process. This pre-tinning is a 60/40 lead-tin alloy. Call Amphenol for further information on pre-tinning and any other plating of contacts not covered in this catalog.

**Would Flex Assemblies be Necessary or Beneficial for the Application?**

Flex print can radically simplify the assembly of a connector to a system, as well as eliminate wiring errors. Amphenol offers connector flex assemblies through APC, Amphenol Printed Circuits division. Features and benefits of using flex technology include:

- Available for MIL-DTL-38999 (including filter EMI/EMP types), circular connectors
- Sculptures® Flexible Circuits with built-in terminations
- Eliminates failures associated with crimped or solder-on contacts
- Geometrically fit tight space requirements and create a self-locking terminal pad

**Should Other PC Tail Contact Types be Considered?**

Press-Fit Connectors with compliant pins are available which engage the plated through-holes in the board without the need for soldering. This optional contact style offers the following benefits:

- Improved board processing time
- Excellent temperature performance
- Ideal for low-lead applications

For more information on Press-Fit connectors with compliant pins see page 416.

Special Quadrax contacts have been designed with PC tails. Coax, twinax and triax contacts can also have PC tails. Refer to the High Speed contacts section of this catalog.



Compliant Pin Contacts in a Bayonet 38999 Catalog



Special Design with Longer PC Tails in a 38999 Composite Shell Connector. Also shows an Alignment Disc.



Flex Termination for Attachment to PC Boards



Quadrax PC Tail Contacts Combined with Standard PC Tail Contacts



Quadrax Contacts with PC Tails in a 38999 Connector with Special Stand-off Shell

# Circular Connectors – PCB Contacts

## Insert Availability

The following table lists the most commonly used insert arrangements for printed circuit board application of MIL-DTL-38999 circular connectors. This represents the most readily available patterns within these series. See illustrations of these selected patterns on the following pages. If you require other arrangements than what are shown here, consult Amphenol for further availability.

Example: Shell Size is the first number (8–3) Insert Arrangement is second number.

| MIL-DTL-38999                    |                                  |  | Service Rating | Total Contacts | Contact Size* |    |    |
|----------------------------------|----------------------------------|--|----------------|----------------|---------------|----|----|
| JT<br>MIL-DTL-38999<br>Series II | LJT<br>MIL-DTL-38999<br>Series I | Tri-Start<br>MIL-DTL-38999<br>Series III |                |                | 22D           | 20 | 16 |
| 8-3                              | 9-3                              |  | M/I            | 3              |               | 3  |    |
| 8-35                             | 9-35                             | 9-35                                     | M              | 6              | 6             |    |    |
| 8-98                             | 9-98                             | 9-98                                     | I              | 3              |               | 3  |    |
| 10-5                             | 11-5                             | 11-5                                     | I              | 5              |               | 5  |    |
|                                  | 11-6                             |  | I              | 6              |               | 6  |    |
| 10-35                            | 11-35                            | 11-35                                    | M              | 13             | 13            |    |    |
| 12-3                             | 13-3                             |  | II             | 3              |               |    | 3  |
| 12-35                            | 13-35                            | 13-35                                    | M              | 22             | 22            |    |    |
| 14-18                            | 15-18                            | 15-18                                    | I              | 18             |               | 18 |    |
| 14-19                            | 15-19                            | 15-19                                    | I              | 19             |               | 19 |    |
| 14-35                            | 15-35                            | 15-35                                    | M              | 37             | 37            |    |    |
| 16-26                            | 17-26                            | 17-26                                    | I              | 26             |               | 26 |    |
| 16-35                            | 17-35                            | 17-35                                    | M              | 55             | 55            |    |    |
| 18-11                            | 19-11                            | 19-11                                    | II             | 11             |               |    | 11 |
| 18-32                            | 19-32                            | 19-32                                    | I              | 32             |               | 32 |    |
| 18-35                            | 19-35                            | 19-35                                    | M              | 66             | 66            |    |    |
| 20-27                            | 21-27                            |  | I              | 27             |               | 27 |    |
| 20-35                            | 21-35                            | 21-35                                    | M              | 79             | 79            |    |    |
| 20-41                            | 21-41                            | 21-41                                    | I              | 41             |               | 41 |    |
| 22-35                            | 23-35                            | 23-35                                    | M              | 100            | 100           |    |    |
| 22-55                            | 23-55                            | 23-55                                    | I              | 55             |               | 55 |    |
| 24-31                            |                                  |  | I              | 31             |               |    | 31 |
| 24-35                            | 25-35                            | 25-35                                    | M              | 128            | 128           |    |    |
| 24-61                            | 25-61                            | 25-61                                    | I              | 61             |               | 61 |    |

\* For information on size 12 PC tail contacts consult Amphenol Aerospace.

Printed Circuit Boards are available in other series like MIL-DTL-26482 and MIL-5015 Connectors. Please contact Amphenol Aerospace for more information.



**MIL-DTL-26482**

- Medium size, widely used circular
- Operating voltage to 1,000 VAC (RMS) at sea level
- Series 1 (PT) - Bayonet coupling - most commonly used in PCB applications
- Environmentally resistant
- Solder or crimp front and rear release contacts in mating plug

Black/green zinc alloy plating (cadmium-free) available



**MIL-5015 Connector**

- Medium–heavy weight, time-tested circular
  - Operating voltage to 1,500 VAC (RMS) at sea level
  - Environmentally resistant or general duty
  - Threaded coupling
  - Solder or crimp rear insertion contacts in mating plug
- Black/green zinc alloy plating (cadmium-free) available

III  
II  
I  
SJT  
38999

26482  
Matrix 2

83723 III  
Matrix Pyle

5015  
Crimp Rear Release Matrix

26500 Pyle

Printed  
Circuit Board

EMI Filter  
Transient

Fiber Optics

High Speed  
Contacts

Options  
Others

To avoid cross-plugging problems in applications requiring the use of more than one connector of the same series, size and arrangement, alternate rotations are available as indicated in the accompanying charts.

**In MIL-DTL-38999 Series I, II and III connectors the rotation is based on rotating the master key/keyway in the connector shell.**

A plug with a given rotation letter will mate with a receptacle with the same rotation letter. Only the master key/keyway rotates in the shell, and the insert always remains in the same position relative to the minor keys. Refer to diagrams below for each connector series.

#### LJT (MIL-DTL-38999 Series I) KEY/KEYWAY ROTATION

| AB ANGLE OF ROTATION (Degrees) |         |    |    |     |     |
|--------------------------------|---------|----|----|-----|-----|
| Shell Size                     | Normal° | A° | B° | C°  | D°  |
| 9                              | 95      | 77 | —  | —   | 113 |
| 11                             | 95      | 81 | 67 | 123 | 109 |
| 13                             | 95      | 75 | 63 | 127 | 115 |
| 15                             | 95      | 74 | 61 | 129 | 116 |
| 17                             | 95      | 77 | 65 | 125 | 113 |
| 19                             | 95      | 77 | 65 | 125 | 113 |
| 21                             | 95      | 77 | 65 | 125 | 113 |
| 23                             | 95      | 80 | 69 | 121 | 110 |
| 25                             | 95      | 80 | 69 | 121 | 110 |

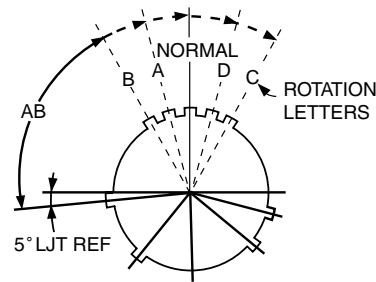

RELATIVE POSSIBLE POSITION OF ROTATED MASTER KEYWAY (front face of LJT connector receptacle shown)

#### JT (MIL-DTL-38999 Series II) KEY/KEYWAY ROTATION

| AB ANGLE OF ROTATION (Degrees) |         |    |    |     |     |
|--------------------------------|---------|----|----|-----|-----|
| Shell Size                     | Normal° | A° | B° | C°  | D°  |
| 8                              | 100     | 82 | —  | —   | 118 |
| 10                             | 100     | 86 | 72 | 128 | 114 |
| 12                             | 100     | 80 | 68 | 132 | 120 |
| 14                             | 100     | 79 | 66 | 134 | 121 |
| 16                             | 100     | 82 | 70 | 130 | 118 |
| 18                             | 100     | 82 | 70 | 130 | 118 |
| 20                             | 100     | 82 | 70 | 130 | 118 |
| 22                             | 100     | 85 | 74 | 126 | 115 |
| 24                             | 100     | 85 | 74 | 126 | 115 |

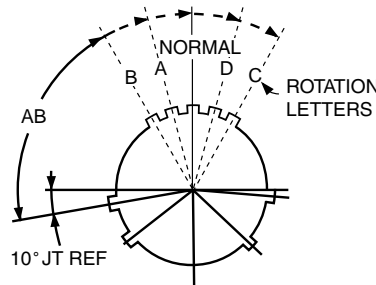

RELATIVE POSSIBLE POSITION OF ROTATED MASTER KEYWAY (front face of JT connector receptacle shown)

#### Tri-Start (MIL-DTL-38999 Series III) KEY/KEYWAY ROTATION

| Shell Size     | Key & Keyway Arrangement Identification Letter | AR° BSC | BR° BSC | CR° BSC | DR° BSC |
|----------------|--|---------|---------|---------|---------|
| 9              | N  | 105     | 140     | 215     | 265     |
|                | A  | 102     | 132     | 248     | 320     |
|                | B  | 80      | 118     | 230     | 312     |
|                | C  | 35      | 140     | 205     | 275     |
|                | D  | 64      | 155     | 234     | 304     |
| 11, 13, and 15 | E  | 91      | 131     | 197     | 240     |
|                | N  | 95      | 141     | 208     | 236     |
|                | A  | 113     | 156     | 182     | 292     |
|                | B  | 90      | 145     | 195     | 252     |
|                | C  | 53      | 156     | 220     | 255     |
| 17 and 19      | D  | 119     | 146     | 176     | 298     |
|                | E  | 51      | 141     | 184     | 242     |
|                | N  | 80      | 142     | 196     | 293     |
|                | A  | 135     | 170     | 200     | 310     |
|                | B  | 49      | 169     | 200     | 244     |
| 21, 23, and 25 | C  | 66      | 140     | 200     | 257     |
|                | D  | 62      | 145     | 180     | 280     |
|                | E  | 79      | 153     | 197     | 272     |
|                | N  | 80      | 142     | 196     | 293     |
|                | A  | 135     | 170     | 200     | 310     |
|                | B  | 49      | 169     | 200     | 244     |
|                | C  | 66      | 140     | 200     | 257     |
|                | D  | 62      | 145     | 180     | 280     |
|                | E  | 79      | 153     | 197     | 272     |

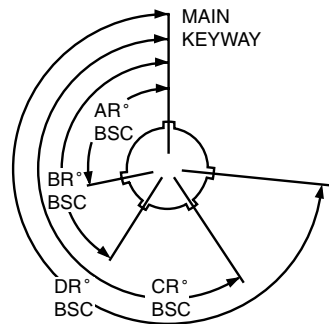

RELATIVE POSSIBLE POSITION OF ROTATED MASTER KEYWAY (front face of Tri-Start connector receptacle shown)

#### MIL-DTL-38999 SERIES I LJT & SERIES II JT CONNECTORS ALTERNATE ROTATION CROSS REFERENCE LETTERS

| Pins in Alternate Rotations | Sockets in Alternate Rotations |
|-----------------------------|--------------------------------|
| PA = E                      | SA = F                         |
| PB = R                      | SB = T                         |
| PC = W                      | SC = X                         |
| PD = Y                      | SD = Z                         |

**Explanation:**  
Use P at end of part number for pin contacts in Normal position. Use S at end of part number for socket contacts in Normal position. Use cross reference letters given in chart above for alternate rotations.

#### MIL-DTL-38999 SERIES III, TRI-START CONNECTORS ALTERNATE ROTATION CROSS REFERENCE LETTERS

| Pins in Alternate Rotations | Sockets in Alternate Rotations |
|-----------------------------|--------------------------------|
| PA = G                      | SA = H                         |
| PB = I                      | SB = J                         |
| PC = K                      | SC = L                         |
| PD = M                      | SD = N                         |
| PE = R                      | SE = T                         |

**Explanation:**  
Use P at end of part number for pin contacts in Normal position. Use S at end of part number for socket contacts in Normal position. Use cross reference letters given in chart above for alternate rotations.

## Insert Arrangement #8-3 / 9-3

|                 |                                  |                                  |  |                       |                 |                   |
|-----------------|----------------------------------|----------------------------------|--|-----------------------|-----------------|-------------------|
| Connector Type: | JT<br>MIL-DTL-38999<br>Series II | LJT<br>MIL-DTL-38999<br>Series I | Tri-Start<br>MIL-DTL-38999<br>Series III | Number of<br>Contacts | Contact<br>Size | Service<br>Rating |
|                 | 8-3                              | 9-3                              | NA                                       |                       |                 |                   |

**Contact Locations**  
Front face of pin insert shown

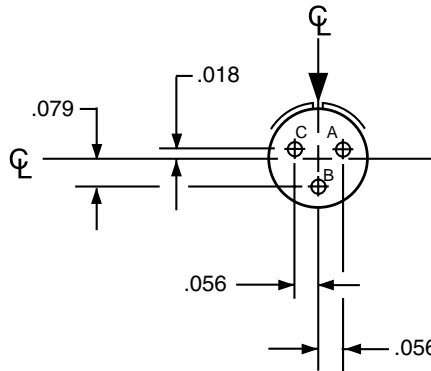

\*Service Rating: M for MIL-DTL-38999

## Insert Arrangement #8-35 / 9-35

|                 |                                  |                                  |  |                       |                 |                   |
|-----------------|----------------------------------|----------------------------------|--|-----------------------|-----------------|-------------------|
| Connector Type: | JT<br>MIL-DTL-38999<br>Series II | LJT<br>MIL-DTL-38999<br>Series I | Tri-Start<br>MIL-DTL-38999<br>Series III | Number of<br>Contacts | Contact<br>Size | Service<br>Rating |
|                 | 8-35                             | 9-35                             | 9-35                                     |                       |                 |                   |

**Contact Locations**  
Front face of pin insert shown

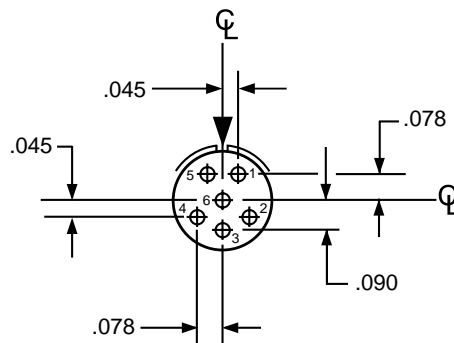

All dimensions for reference only. For alternate rotations see page 240.  
Note: Shown in this catalog are the most common insert patterns for PCB applications. For availability of other arrangements, consult Amphenol Corp., Sidney, NY.

- III 38999
- II
- I
- SJT
- 26482 Matrix 2
- 83723 III Matrix Pyle
- 5015 Crimp Rear Release Matrix
- 26500 Pyle

- Printed Circuit Board
- EMI Filter Transient
- Fiber Optics
- High Speed Contacts
- Options Others



**Insert Arrangement #8-98 / 9-98**

Connector Type:

|                                  |                                  |  |
|----------------------------------|----------------------------------|--|
| JT<br>MIL-DTL-38999<br>Series II | LJT<br>MIL-DTL-38999<br>Series I | Tri-Start<br>MIL-DTL-38999<br>Series III |
| 8-98                             | 9-98                             | 9-98                                     |

Insert Designation:

| Number of Contacts | Contact Size | Service Rating |
|--------------------|--------------|----------------|
| 3                  | 20           | I              |

**Contact Locations**

Front face of pin insert shown

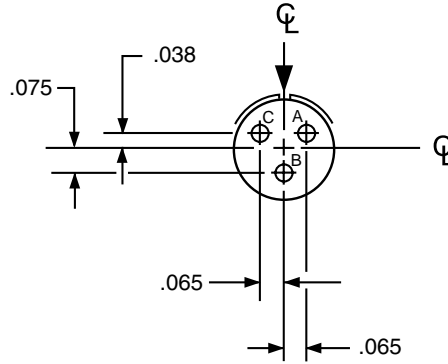

38999  
SJT I II III

26482  
Matrix 2

83723 III  
Matrix Pyle

5015  
Crimp Rear  
Release Matrix

26500 Pyle

Printed  
Circuit Board

EMI Filter  
Transient

Fiber Optics

High Speed  
Contacts

Options  
Others

**Insert Arrangement #10-5 / 11-5**

Connector Type:

|                                  |                                  |  |
|----------------------------------|----------------------------------|--|
| JT<br>MIL-DTL-38999<br>Series II | LJT<br>MIL-DTL-38999<br>Series I | Tri-Start<br>MIL-DTL-38999<br>Series III |
| 10-5                             | 11-5                             | 11-5                                     |

Insert Designation:

| Number of Contacts | Contact Size | Service Rating |
|--------------------|--------------|----------------|
| 5                  | 20           | I              |

**Contact Locations**

Front face of pin insert shown

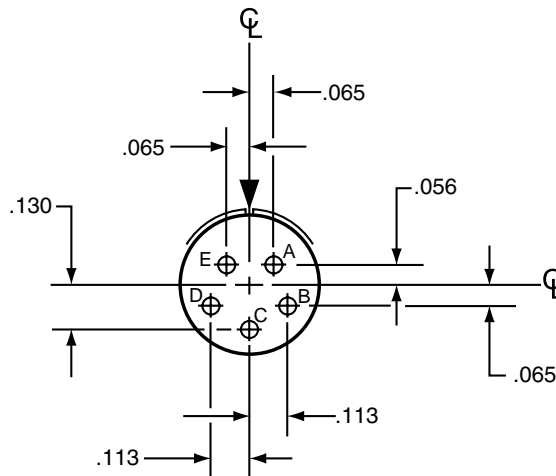

All dimensions for reference only. For alternate rotations see page 240.

Note: Shown in this catalog are the most common insert patterns for PCB applications. For availability of other arrangements, consult Amphenol Corp., Sidney, NY.



## Insert Arrangement #10-6 / 11-6

Connector Type:

|                                  |                                  |  |
|----------------------------------|----------------------------------|--|
| JT<br>MIL-DTL-38999<br>Series II | LJT<br>MIL-DTL-38999<br>Series I | Tri-Start<br>MIL-DTL-38999<br>Series III |
| NA                               | 11-6                             | NA                                       |

Insert Designation:

| Number of Contacts | Contact Size | Service Rating |
|--------------------|--------------|----------------|
| 6                  | 20           | I              |

Contact Locations

Front face of pin insert shown

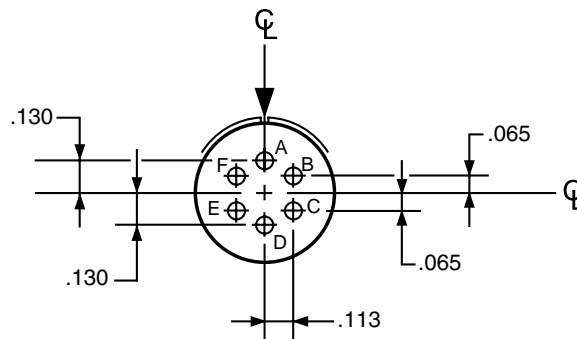

## Insert Arrangement #10-35 / 11-35

Connector Type:

|                                  |                                  |  |
|----------------------------------|----------------------------------|--|
| JT<br>MIL-DTL-38999<br>Series II | LJT<br>MIL-DTL-38999<br>Series I | Tri-Start<br>MIL-DTL-38999<br>Series III |
| 10-35                            | 11-35                            | 11-35                                    |

Insert Designation:

| Number of Contacts | Contact Size | Service Rating |
|--------------------|--------------|----------------|
| 13                 | 22D          | M              |

Contact Locations

Front face of pin insert shown

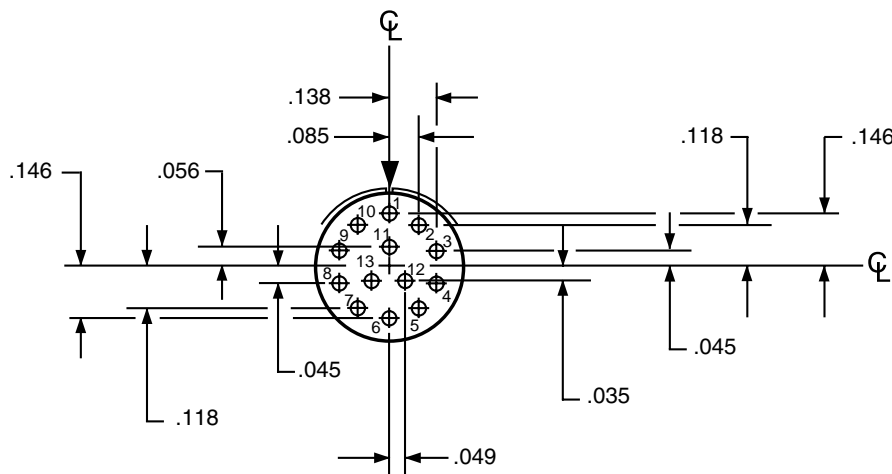

All dimensions for reference only. For alternate rotations see page 240.

Note: Shown in this catalog are the most common insert patterns for PCB applications. For availability of other arrangements, consult Amphenol Corp., Sidney, NY.

38999  
III  
II  
I  
SJT

26482  
Matrix 2

83723 III  
Matrix  
Pyle

5015  
Crimp Rear  
Release Matrix

26500 Pyle

Printed  
Circuit Board

EMI Filter  
Transient

Fiber Optics

High Speed  
Contacts

Options  
Others

### Insert Arrangement #12-3 / 13-3

Connector Type:

|                                  |                                  |  |
|----------------------------------|----------------------------------|--|
| JT<br>MIL-DTL-38999<br>Series II | LJT<br>MIL-DTL-38999<br>Series I | Tri-Start<br>MIL-DTL-38999<br>Series III |
| 12-3                             | 13-3                             | NA                                       |

| Number of Contacts | Contact Size | Service Rating |
|--------------------|--------------|----------------|
| 3                  | 16           | II             |

Insert Designation:

**Contact Locations**

Front face of pin insert shown

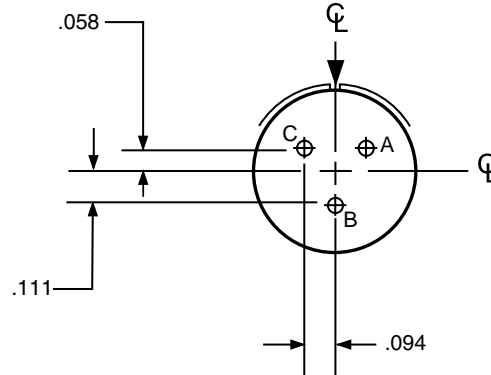

### Insert Arrangement #12-35 / 13-35

Connector Type:

|                                  |                                  |  |
|----------------------------------|----------------------------------|--|
| JT<br>MIL-DTL-38999<br>Series II | LJT<br>MIL-DTL-38999<br>Series I | Tri-Start<br>MIL-DTL-38999<br>Series III |
| 12-35                            | 13-35                            | 13-35                                    |

| Number of Contacts | Contact Size | Service Rating |
|--------------------|--------------|----------------|
| 22                 | 22D          | M              |

Insert Designation:

**Contact Locations**

Front face of pin insert shown

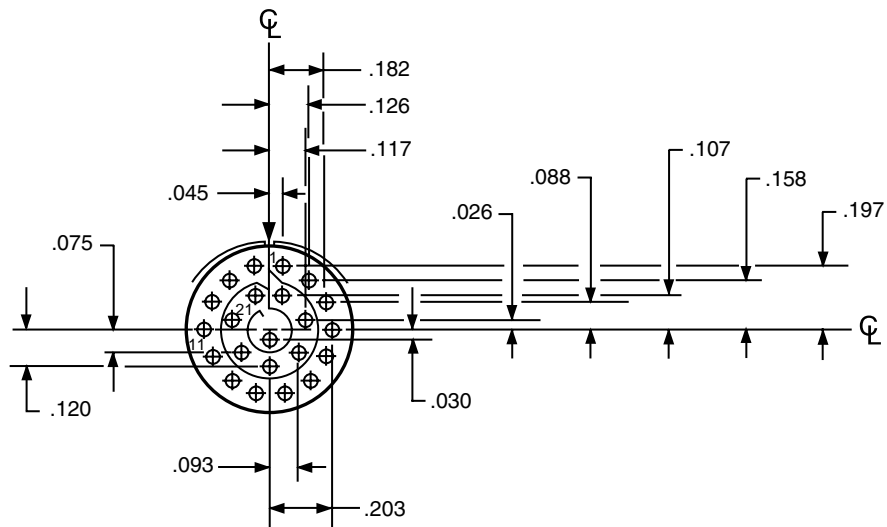

All dimensions for reference only. For alternate rotations see page 240.

Note: Shown in this catalog are the most common insert patterns for PCB applications. For availability of other arrangements, consult Amphenol Corp., Sidney, NY.

## Insert Arrangement #14-18 / 15-18

|                     |                                  |                                  |  |                    |              |                |
|---------------------|----------------------------------|----------------------------------|--|--------------------|--------------|----------------|
| Connector Type:     | JT<br>MIL-DTL-38999<br>Series II | LJT<br>MIL-DTL-38999<br>Series I | Tri-Start<br>MIL-DTL-38999<br>Series III | Number of Contacts | Contact Size | Service Rating |
| Insert Designation: | 14-18                            | 15-18                            | 15-18                                    | 18                 | 20           | I              |

**Contact Locations**  
Front face of pin insert shown

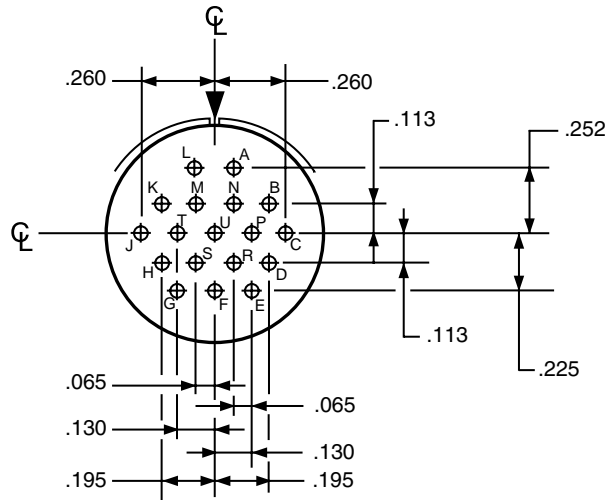

## Insert Arrangement #14-19 / 15-19

|                     |                                  |                                  |  |                    |              |                |
|---------------------|----------------------------------|----------------------------------|--|--------------------|--------------|----------------|
| Connector Type:     | JT<br>MIL-DTL-38999<br>Series II | LJT<br>MIL-DTL-38999<br>Series I | Tri-Start<br>MIL-DTL-38999<br>Series III | Number of Contacts | Contact Size | Service Rating |
| Insert Designation: | 14-19                            | 15-19                            | 15-19                                    | 19                 | 20           | I              |

**Contact Locations**  
Front face of pin insert shown

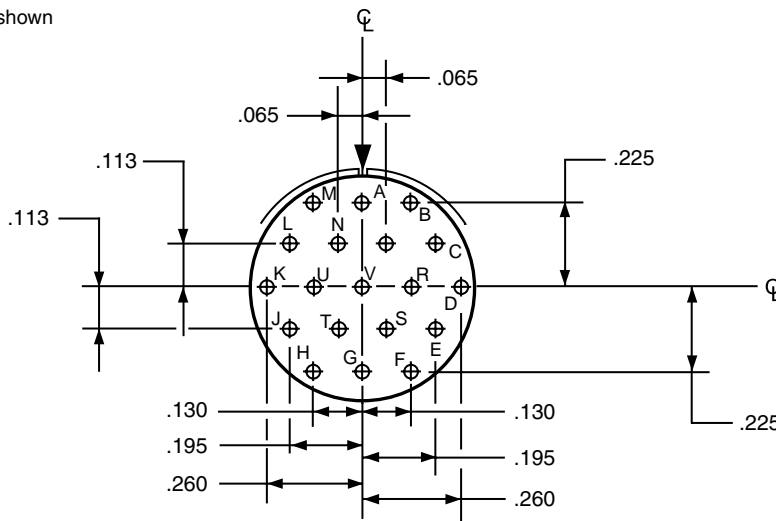

All dimensions for reference only. For alternate rotations see page 240.

Note: Shown in this catalog are the most common insert patterns for PCB applications. For availability of other arrangements, consult Amphenol Corp., Sidney, NY.

- III 38999
- II
- I
- SJT
- 26482 Matrix 2
- 83723 III Matrix Pyle
- 5015 Crimp Rear Release Matrix
- 26500 Pyle

- Printed Circuit Board
- EMI Filter Transient
- Fiber Optics
- High Speed Contacts
- Options Others

### Insert Arrangement #14-35 / 15-35

Connector Type:

|                                  |                                  |  |
|----------------------------------|----------------------------------|--|
| JT<br>MIL-DTL-38999<br>Series II | LJT<br>MIL-DTL-38999<br>Series I | Tri-Start<br>MIL-DTL-38999<br>Series III |
| 14-35                            | 15-35                            | 15-35                                    |

Insert Designation:

| Number of Contacts | Contact Size | Service Rating |
|--------------------|--------------|----------------|
| 37                 | 22D          | M              |

#### Contact Locations

Front face of pin insert shown

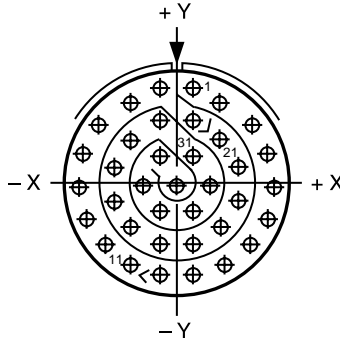

| Contact Number | Location |        |
|----------------|----------|--------|
|                | X Axis   | Y Axis |
| 1              | +0.045   | +0.262 |
| 2              | +0.123   | +0.217 |
| 3              | +0.211   | +0.160 |
| 4              | +0.254   | +0.080 |
| 5              | +0.266   | -0.010 |
| 6              | +0.247   | -0.098 |
| 7              | +0.200   | -0.175 |
| 8              | +0.130   | -0.232 |
| 9              | +0.045   | -0.262 |
| 10             | -0.045   | -0.262 |
| 11             | -0.130   | -0.232 |
| 12             | -0.200   | -0.175 |
| 13             | -0.247   | -0.098 |
| 14             | -0.266   | -0.010 |
| 15             | -0.254   | +0.080 |
| 16             | -0.211   | +0.160 |
| 17             | -0.123   | +0.217 |
| 18             | -0.045   | +0.262 |
| 19             | +0.045   | +0.172 |
| 20             | +0.123   | +0.119 |

| Contact Number | Location |        |
|----------------|----------|--------|
|                | X Axis   | Y Axis |
| 21             | +0.170   | +0.040 |
| 22             | +0.170   | -0.050 |
| 23             | +0.123   | -0.127 |
| 24             | +0.045   | -0.172 |
| 25             | -0.045   | -0.172 |
| 26             | -0.123   | -0.127 |
| 27             | -0.170   | -0.050 |
| 28             | -0.170   | +0.040 |
| 29             | -0.123   | +0.119 |
| 30             | -0.045   | +0.172 |
| 31             | +0.045   | +0.074 |
| 32             | +0.090   | -0.004 |
| 33             | +0.045   | -0.082 |
| 34             | -0.045   | -0.082 |
| 35             | -0.090   | -0.004 |
| 36             | -0.045   | +0.074 |
| 37             | .000     | -0.004 |

### Insert Arrangement #16-26 / 17-26

Connector Type:

|                                  |                                  |  |
|----------------------------------|----------------------------------|--|
| JT<br>MIL-DTL-38999<br>Series II | LJT<br>MIL-DTL-38999<br>Series I | Tri-Start<br>MIL-DTL-38999<br>Series III |
| NA                               | 17-26                            | 17-26                                    |

Insert Designation:

| Number of Contacts | Contact Size | Service Rating |
|--------------------|--------------|----------------|
| 26                 | 20           | I              |

#### Contact Locations

Front face of pin insert shown

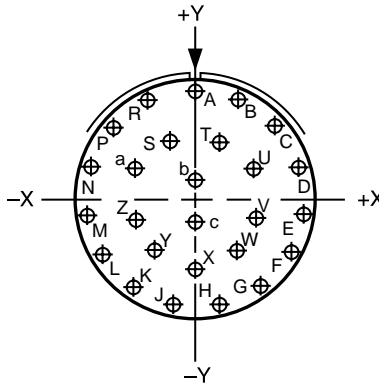

| Contact Number | Location |        |
|----------------|----------|--------|
|                | X Axis   | Y Axis |
| A              | .000     | +0.321 |
| B              | +0.131   | +0.293 |
| C              | +0.239   | +0.214 |
| D              | +0.305   | +0.099 |
| E              | +0.319   | -0.034 |
| F              | +0.278   | -0.161 |
| G              | +0.189   | -0.260 |
| H              | +0.067   | -0.314 |
| J              | -0.067   | -0.314 |
| K              | -0.189   | -0.260 |
| L              | -0.278   | -0.161 |
| M              | -0.319   | -0.034 |
| N              | -0.305   | +0.099 |
| P              | -0.239   | +0.214 |

| Contact Number | Location |        |
|----------------|----------|--------|
|                | X Axis   | Y Axis |
| R              | -0.131   | +0.293 |
| S              | -0.070   | +0.177 |
| T              | +0.070   | +0.177 |
| U              | +0.175   | +0.094 |
| V              | +0.178   | -0.036 |
| W              | +0.119   | -0.151 |
| X              | .000     | -0.203 |
| Y              | -0.119   | -0.151 |
| Z              | -0.178   | -0.036 |
| a              | -0.175   | +0.094 |
| b              | .000     | +0.065 |
| c              | .000     | -0.065 |

All dimensions for reference only. For alternate rotations see page 240.

Note: Shown in this catalog are the most common insert patterns for PCB applications. For availability of other arrangements, consult Amphenol Corp., Sidney, NY.

# Circular Connectors – PCB Contacts

## Insert Arrangements

### Insert Arrangement #16-35 / 17-35

Connector Type:

|                                  |                                  |  |
|----------------------------------|----------------------------------|--|
| JT<br>MIL-DTL-38999<br>Series II | LJT<br>MIL-DTL-38999<br>Series I | Tri-Start<br>MIL-DTL-38999<br>Series III |
| 16-35                            | 17-35                            | 17-35                                    |

Insert Designation:

| Number of Contacts | Contact Size | Service Rating |
|--------------------|--------------|----------------|
| 55                 | 22D          | M              |

#### Contact Locations

Front face of pin insert shown

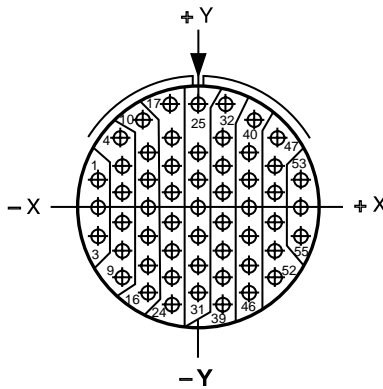

| Contact Hole Locations |          |        |
|------------------------|----------|--------|
| Contact Number         | Location |        |
|                        | X Axis   | Y Axis |
| 1                      | -.312    | +.086  |
| 2                      | -.312    | -.004  |
| 3                      | -.312    | -.094  |
| 4                      | -.242    | +.221  |
| 5                      | -.234    | +.131  |
| 6                      | -.234    | +.041  |
| 7                      | -.234    | -.049  |
| 8                      | -.234    | -.139  |
| 9                      | -.234    | -.229  |
| 10                     | -.172    | +.279  |
| 11                     | -.156    | +.176  |
| 12                     | -.156    | +.086  |
| 13                     | -.156    | -.004  |
| 14                     | -.156    | -.094  |
| 15                     | -.156    | -.184  |
| 16                     | -.156    | -.274  |
| 17                     | -.089    | +.316  |
| 18                     | -.078    | +.221  |
| 19                     | -.078    | +.131  |
| 20                     | -.078    | +.041  |
| 21                     | -.078    | -.049  |
| 22                     | -.078    | -.139  |
| 23                     | -.078    | -.229  |
| 24                     | -.078    | -.319  |
| 25                     | .000     | +.329  |
| 26                     | .000     | +.176  |
| 27                     | .000     | +.086  |
| 28                     | .000     | -.004  |
| 29                     | .000     | -.094  |
| 30                     | .000     | -.184  |

| Contact Hole Locations |          |        |
|------------------------|----------|--------|
| Contact Number         | Location |        |
|                        | X Axis   | Y Axis |
| 31                     | .000     | -.274  |
| 32                     | +.089    | +.316  |
| 33                     | +.078    | +.221  |
| 34                     | +.078    | +.131  |
| 35                     | +.078    | +.041  |
| 36                     | +.078    | -.049  |
| 37                     | +.078    | -.139  |
| 38                     | +.078    | -.229  |
| 39                     | +.078    | -.319  |
| 40                     | +.172    | +.279  |
| 41                     | +.156    | +.176  |
| 42                     | +.156    | +.086  |
| 43                     | +.156    | -.004  |
| 44                     | +.156    | -.094  |
| 45                     | +.156    | -.184  |
| 46                     | +.156    | -.274  |
| 47                     | +.242    | +.221  |
| 48                     | +.234    | +.131  |
| 49                     | +.234    | +.041  |
| 50                     | +.234    | -.049  |
| 51                     | +.234    | -.139  |
| 52                     | +.234    | -.229  |
| 53                     | +.312    | +.086  |
| 54                     | +.312    | -.004  |
| 55                     | +.312    | -.094  |

38999  
III  
II  
I  
SJT

26482  
Matrix 2

83723 III  
Matrix  
Pyle

5015  
Crimp Rear  
Release Matrix

26500 Pyle

Printed  
Circuit Board

EMI Filter  
Transient

Fiber Optics

High Speed  
Contacts

Options  
Others

All dimensions for reference only. For alternate rotations see page 240.

Note: Shown in this catalog are the most common insert patterns for PCB applications. For availability of other arrangements, consult Amphenol Corp., Sidney, NY.

38999  
SJT I II III

26482  
Matrix 2

83723 III  
Matrix Pyle

5015  
Crimp Rear Release Matrix

26500 Pyle

Printed  
Circuit Board

EMI Filter  
Transient

Fiber Optics

High Speed  
Contacts

Options  
Others

### Insert Arrangement #18-11 / 19-11

|                            |   |   |   |
|----------------------------|---|---|---|
| <b>Connector Type:</b>     | <b>JT</b><br>MIL-DTL-38999<br>Series II | <b>LJT</b><br>MIL-DTL-38999<br>Series I | <b>Tri-Start</b><br>MIL-DTL-38999<br>Series III |
| <b>Insert Designation:</b> | <b>18-11</b>                            | <b>19-11</b>                            | <b>19-11</b>                                    |

|                           |                     |                       |
|---------------------------|---------------------|-----------------------|
| <b>Number of Contacts</b> | <b>Contact Size</b> | <b>Service Rating</b> |
| <b>11</b>                 | <b>16</b>           | <b>II</b>             |

**Contact Locations**  
Front face of pin insert shown

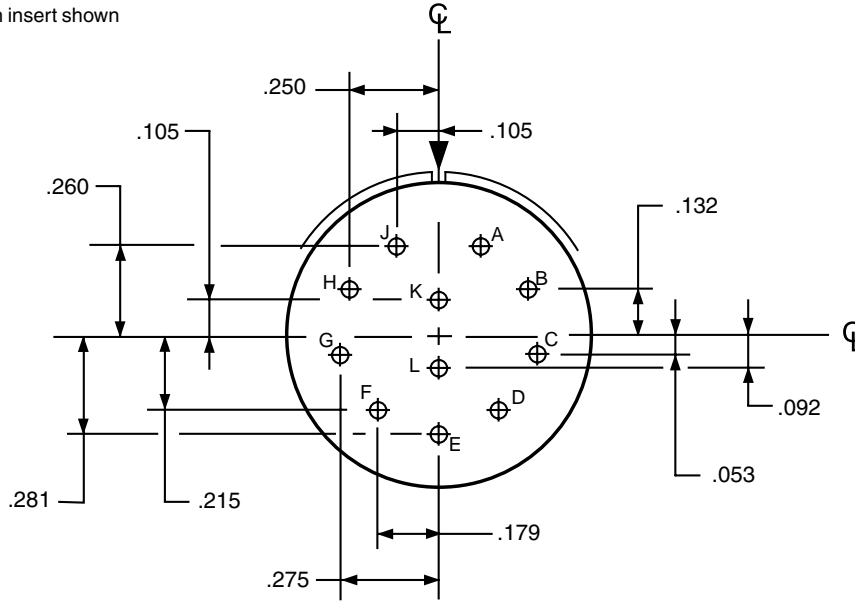

### Insert Arrangement #18-32 / 19-32

|                            |   |   |   |
|----------------------------|---|---|---|
| <b>Connector Type:</b>     | <b>JT</b><br>MIL-DTL-38999<br>Series II | <b>LJT</b><br>MIL-DTL-38999<br>Series I | <b>Tri-Start</b><br>MIL-DTL-38999<br>Series III |
| <b>Insert Designation:</b> | <b>18-32</b>                            | <b>19-32</b>                            | <b>19-32</b>                                    |

|                           |                     |                       |
|---------------------------|---------------------|-----------------------|
| <b>Number of Contacts</b> | <b>Contact Size</b> | <b>Service Rating</b> |
| <b>32</b>                 | <b>20</b>           | <b>I</b>              |

**Contact Locations**  
Front face of pin insert shown

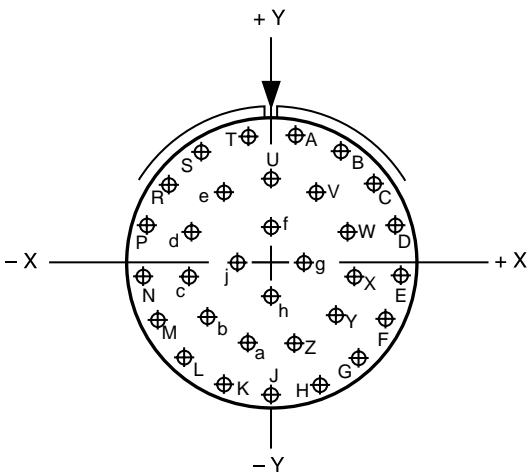

| Contact Hole Locations |          |        |
|------------------------|----------|--------|
| Contact Letter         | Location |        |
|                        | X Axis   | Y Axis |
| A                      | +.066    | +.353  |
| B                      | +.189    | +.305  |
| C                      | +.286    | +.217  |
| D                      | +.345    | +.098  |
| E                      | +.357    | -.033  |
| F                      | +.321    | -.160  |
| G                      | +.242    | -.265  |
| H                      | +.130    | -.335  |
| J                      | .000     | -.359  |
| K                      | -.130    | -.335  |
| L                      | -.242    | -.265  |
| M                      | -.321    | -.160  |
| N                      | -.357    | -.033  |
| P                      | -.345    | +.098  |
| R                      | -.286    | +.217  |
| S                      | -.189    | +.305  |

| Contact Hole Locations |          |        |
|------------------------|----------|--------|
| Contact Letter         | Location |        |
|                        | X Axis   | Y Axis |
| T                      | -.066    | +.353  |
| U                      | .000     | +.230  |
| V                      | +.124    | +.193  |
| W                      | +.209    | +.095  |
| X                      | +.228    | -.033  |
| Y                      | +.174    | -.151  |
| Z                      | +.065    | -.221  |
| a                      | -.065    | -.221  |
| b                      | -.174    | -.151  |
| c                      | -.228    | -.033  |
| d                      | -.209    | +.095  |
| e                      | -.124    | +.193  |
| f                      | .000     | +.096  |
| g                      | +.096    | .000   |
| h                      | .000     | -.096  |
| j                      | -.096    | .000   |

All dimensions for reference only. For alternate rotations see page 240.

Note: Shown in this catalog are the most common insert patterns for PCB applications. For availability of other arrangements, consult Amphenol Corp., Sidney, NY.



### Insert Arrangement #18-35 / 19-35

|                     |                                  |                                  |  |
|---------------------|----------------------------------|----------------------------------|--|
| Connector Type:     | JT<br>MIL-DTL-38999<br>Series II | LJT<br>MIL-DTL-38999<br>Series I | Tri-Start<br>MIL-DTL-38999<br>Series III |
|                     | 18-35                            | 19-35                            | 19-35                                    |
| Insert Designation: | 18-35                            | 19-35                            | 19-35                                    |

|                    |              |                |
|--------------------|--------------|----------------|
| Number of Contacts | Contact Size | Service Rating |
| 66                 | 22D          | M              |

**Contact Locations**  
Front face of pin insert shown

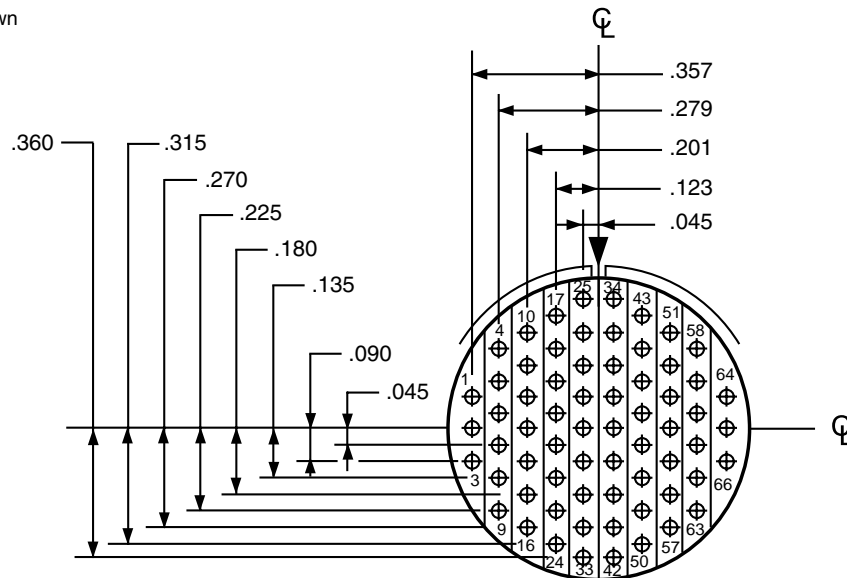

### Insert Arrangement #20-27 / 21-27

|                     |                                  |                                  |  |
|---------------------|----------------------------------|----------------------------------|--|
| Connector Type:     | JT<br>MIL-DTL-38999<br>Series II | LJT<br>MIL-DTL-38999<br>Series I | Tri-Start<br>MIL-DTL-38999<br>Series III |
|                     | 20-27                            | 21-27                            | NA                                       |
| Insert Designation: | 20-27                            | 21-27                            | NA                                       |

|                    |              |                |
|--------------------|--------------|----------------|
| Number of Contacts | Contact Size | Service Rating |
| 27                 | 20           | I              |

**Contact Locations**  
Front face of pin insert shown

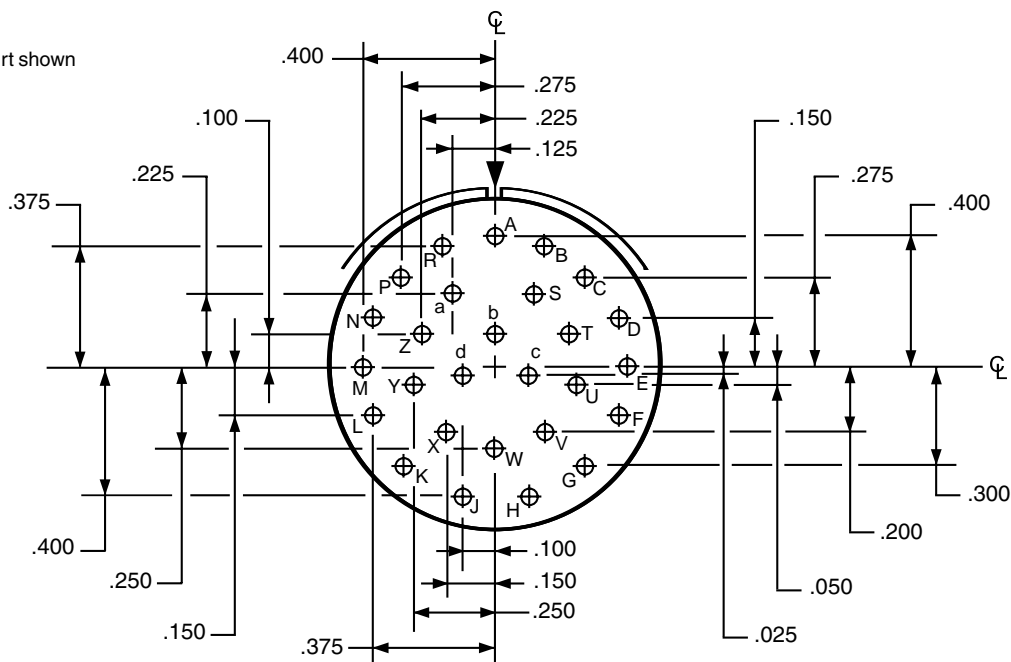

All dimensions for reference only. For alternate rotations see page 240.

Note: Shown in this catalog are the most common insert patterns for PCB applications. For availability of other arrangements, consult Amphenol Corp., Sidney, NY.

- III 38999
- II
- I
- SJT
- 26482 Matrix 2
- 83723 III Matrix Pyle
- 5015 Crimp Rear Release Matrix
- 26500 Pyle

Printed Circuit Board

EMI Filter Transient

Fiber Optics

High Speed Contacts

Options Others

### Insert Arrangement #20-35 / 21-35

|                 |                                  |                                  |  |
|-----------------|----------------------------------|----------------------------------|--|
| Connector Type: | JT<br>MIL-DTL-38999<br>Series II | LJT<br>MIL-DTL-38999<br>Series I | Tri-Start<br>MIL-DTL-38999<br>Series III |
|                 | 20-35                            | 21-35                            | 21-35                                    |

|                    |              |                |
|--------------------|--------------|----------------|
| Number of Contacts | Contact Size | Service Rating |
| 79                 | 22D          | M              |

**Contact Locations**  
Front face of pin insert shown

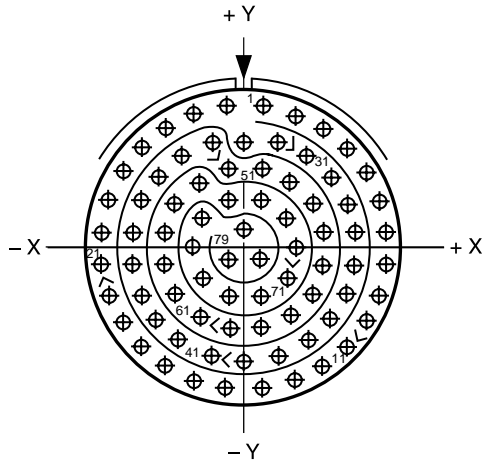

| Contact Number | Location |        |
|----------------|----------|--------|
|                | X Axis   | Y Axis |
| 10             | +0.365   | -.227  |
| 11             | +0.306   | -.302  |
| 12             | +0.232   | -.362  |
| 13             | +0.146   | -.404  |
| 14             | +0.053   | -.426  |
| 15             | -.053    | -.426  |
| 16             | -.146    | -.404  |
| 17             | -.232    | -.362  |
| 18             | -.306    | -.302  |
| 19             | -.365    | -.227  |
| 20             | -.406    | -.141  |
| 21             | -.427    | -.048  |
| 22             | -.427    | +0.048 |
| 23             | -.406    | +0.141 |
| 24             | -.365    | +0.227 |
| 25             | -.306    | +0.302 |
| 26             | -.232    | +0.362 |
| 27             | -.146    | +0.404 |
| 28             | -.053    | +0.426 |
| 29             | .000     | +0.323 |
| 30             | +0.098   | +0.322 |
| 31             | +0.184   | +0.280 |
| 32             | +0.258   | +0.220 |
| 33             | +0.311   | +0.141 |
| 34             | +0.332   | +0.048 |
| 35             | +0.332   | -.048  |
| 36             | +0.311   | -.141  |
| 37             | +0.258   | -.220  |
| 38             | +0.184   | -.280  |
| 39             | +0.098   | -.322  |
| 40             | .000     | -.347  |
| 41             | -.098    | -.322  |
| 42             | -.184    | -.280  |
| 43             | -.258    | -.220  |
| 44             | -.311    | -.141  |

| Contact Number | Location |        |
|----------------|----------|--------|
|                | X Axis   | Y Axis |
| 45             | -.332    | -.048  |
| 46             | -.332    | +0.048 |
| 47             | -.311    | +0.141 |
| 48             | -.258    | +0.220 |
| 49             | -.184    | +0.280 |
| 50             | -.098    | +0.322 |
| 51             | -.048    | +0.241 |
| 52             | +0.048   | +0.241 |
| 53             | +0.134   | +0.199 |
| 54             | +0.208   | +0.139 |
| 55             | +0.237   | +0.048 |
| 56             | +0.237   | -.048  |
| 57             | +0.208   | -.139  |
| 58             | +0.134   | -.199  |
| 59             | +0.048   | -.241  |
| 60             | -.048    | -.241  |
| 61             | -.134    | -.199  |
| 62             | -.208    | -.139  |
| 63             | -.237    | -.048  |
| 64             | -.237    | +0.048 |
| 65             | -.208    | +0.139 |
| 66             | -.134    | +0.199 |
| 67             | -.048    | +0.146 |
| 68             | +0.048   | +0.146 |
| 69             | +0.125   | +0.090 |
| 70             | +0.155   | .000   |
| 71             | +0.125   | -.090  |
| 72             | +0.048   | -.146  |
| 73             | -.048    | -.146  |
| 74             | -.125    | -.090  |
| 75             | -.155    | .000   |
| 76             | -.125    | +0.090 |
| 77             | .000     | +0.053 |
| 78             | +0.048   | -.029  |
| 79             | -.048    | -.029  |

| Contact Number | Location |        |
|----------------|----------|--------|
|                | X Axis   | Y Axis |
| 1              | +0.053   | +0.426 |
| 2              | +0.146   | +0.404 |
| 3              | +0.232   | +0.362 |
| 4              | +0.306   | +0.302 |
| 5              | +0.365   | +0.227 |
| 6              | +0.406   | +0.141 |
| 7              | +0.427   | +0.048 |
| 8              | +0.427   | -.048  |
| 9              | +0.406   | -.141  |

All dimensions for reference only. For alternate rotations see page 240.

Note: Shown in this catalog are the most common insert patterns for PCB applications. For availability of other arrangements, consult Amphenol Corp., Sidney, NY.

# Circular Connectors – PCB Contacts Insert Arrangements

## Insert Arrangement #20-41 / 21-41

Connector Type:

| JT<br>MIL-DTL-38999<br>Series II | LJT<br>MIL-DTL-38999<br>Series I | Tri-Start<br>MIL-DTL-38999<br>Series III |
|----------------------------------|----------------------------------|--|
| 20-41                            | 21-41                            | 21-41                                    |

Insert Designation:

| Number of Contacts | Contact Size | Service Rating |
|--------------------|--------------|----------------|
| 41                 | 20           | I              |

### Contact Locations

Front face of pin insert shown

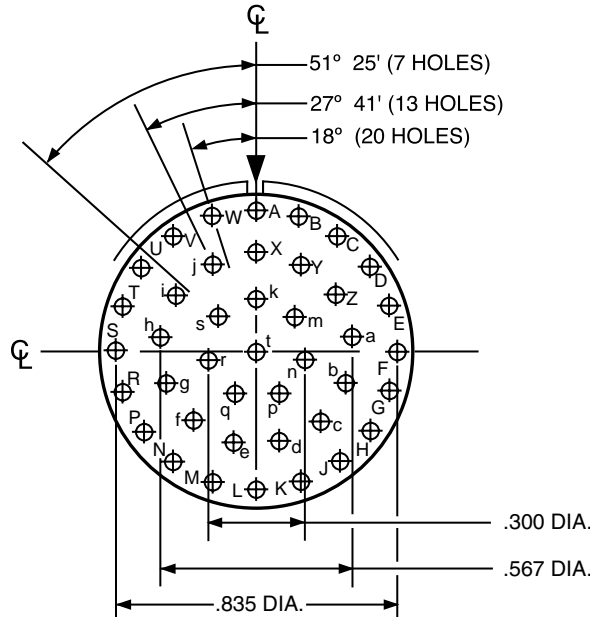

38999  
III  
II  
I  
SJT

26482  
Matrix 2

83723 III  
Matrix  
Pyle

5015  
Crimp Rear  
Release Matrix

26500 Pyle

Printed  
Circuit Board

EMI Filter  
Transient

Fiber Optics

High Speed  
Contacts

Options  
Others

All dimensions for reference only. For alternate rotations see page 240.

Note: Shown in this catalog are the most common insert patterns for PCB applications. For availability of other arrangements, consult Amphenol Corp., Sidney, NY.

- 38999 SJT I II III
- 26482 Matrix 2
- 83723 III Matrix Pyle
- 5015 Crimp Rear Release Matrix
- 26500 Pyle
- Printed Circuit Board
- EMI Filter Transient
- Fiber Optics
- High Speed Contacts
- Options Others

### Insert Arrangement #22-35 / 23-35

|                     |                                  |                                  |  |                    |              |                |
|---------------------|----------------------------------|----------------------------------|--|--------------------|--------------|----------------|
| Connector Type:     | JT<br>MIL-DTL-38999<br>Series II | LJT<br>MIL-DTL-38999<br>Series I | Tri-Start<br>MIL-DTL-38999<br>Series III | Number of Contacts | Contact Size | Service Rating |
| Insert Designation: | 22-35                            | 23-35                            | 23-35                                    | 100                | 22D          | M              |

**Contact Locations**  
Front face of pin insert shown

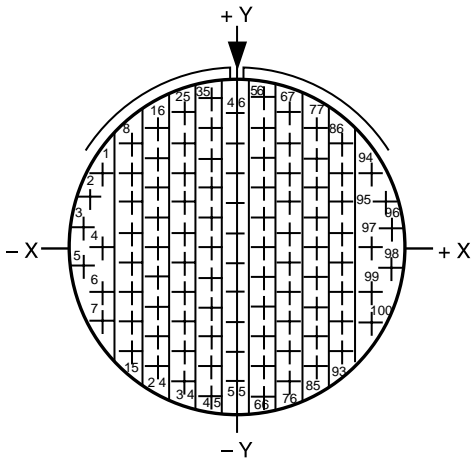

| Contact Number | Location |        |
|----------------|----------|--------|
|                | X Axis   | Y Axis |
| 1              | -.428    | +.241  |
| 2              | -.467    | +.154  |
| 3              | -.488    | +.061  |
| 4              | -.415    | .000   |
| 5              | -.488    | -.061  |
| 6              | -.428    | -.142  |
| 7              | -.428    | -.237  |
| 8              | -.332    | +.333  |
| 9              | -.332    | +.238  |
| 10             | -.332    | +.143  |
| 11             | -.332    | +.048  |
| 12             | -.332    | -.047  |
| 13             | -.332    | -.142  |
| 14             | -.332    | -.237  |
| 15             | -.332    | -.332  |
| 16             | -.249    | +.380  |
| 17             | -.249    | +.285  |
| 18             | -.249    | +.190  |
| 19             | -.249    | +.095  |
| 20             | -.249    | .000   |

| Contact Number | Location |        |
|----------------|----------|--------|
|                | X Axis   | Y Axis |
| 21             | -.249    | -.095  |
| 22             | -.249    | -.190  |
| 23             | -.249    | -.285  |
| 24             | -.249    | -.380  |
| 25             | -.166    | +.428  |
| 26             | -.166    | +.333  |
| 27             | -.166    | +.238  |
| 28             | -.166    | +.143  |
| 29             | -.166    | +.048  |
| 30             | -.166    | -.047  |
| 31             | -.166    | -.142  |
| 32             | -.166    | -.237  |
| 33             | -.166    | -.332  |
| 34             | -.166    | -.427  |
| 35             | -.083    | +.475  |
| 36             | -.083    | +.380  |
| 37             | -.083    | +.285  |
| 38             | -.083    | +.190  |
| 39             | -.083    | +.095  |
| 40             | -.083    | .000   |
| 41             | -.083    | -.095  |
| 42             | -.083    | -.190  |
| 43             | -.083    | -.285  |
| 44             | -.083    | -.380  |
| 45             | -.083    | -.475  |
| 46             | .000     | +.428  |
| 47             | .000     | +.333  |
| 48             | .000     | +.238  |
| 49             | .000     | +.143  |
| 50             | .000     | +.048  |
| 51             | .000     | -.047  |
| 52             | .000     | -.142  |
| 53             | .000     | -.237  |
| 54             | .000     | -.332  |
| 55             | .000     | -.427  |
| 56             | +.083    | +.475  |
| 57             | +.083    | +.380  |
| 58             | +.083    | +.285  |
| 59             | +.083    | +.190  |
| 60             | +.083    | +.095  |

| Contact Number | Location |        |
|----------------|----------|--------|
|                | X Axis   | Y Axis |
| 61             | +.083    | .000   |
| 62             | +.083    | -.095  |
| 63             | +.083    | -.190  |
| 64             | +.083    | -.285  |
| 65             | +.083    | -.380  |
| 66             | +.083    | -.475  |
| 67             | +.166    | +.428  |
| 68             | +.166    | +.333  |
| 69             | +.166    | +.238  |
| 70             | +.166    | +.143  |
| 71             | +.166    | +.048  |
| 72             | +.166    | -.047  |
| 73             | +.166    | -.142  |
| 74             | +.166    | -.237  |
| 75             | +.166    | -.332  |
| 76             | +.166    | -.427  |
| 77             | +.249    | +.380  |
| 78             | +.249    | +.285  |
| 79             | +.249    | +.190  |
| 80             | +.249    | +.095  |
| 81             | +.249    | .000   |
| 82             | +.249    | -.095  |
| 83             | +.249    | -.190  |
| 84             | +.249    | -.285  |
| 85             | +.249    | -.380  |
| 86             | +.332    | +.333  |
| 87             | +.332    | +.238  |
| 88             | +.332    | +.143  |
| 89             | +.332    | +.048  |
| 90             | +.332    | -.047  |
| 91             | +.332    | -.142  |
| 92             | +.332    | -.237  |
| 93             | +.332    | -.332  |
| 94             | +.428    | +.241  |
| 95             | +.467    | +.154  |
| 96             | +.488    | +.061  |
| 97             | +.415    | .000   |
| 98             | +.488    | -.061  |
| 99             | +.428    | -.142  |
| 100            | +.428    | -.237  |

All dimensions for reference only. For alternate rotations see page 240.

Note: Shown in this catalog are the most common insert patterns for PCB applications. For availability of other arrangements, consult Amphenol Corp., Sidney, NY.

## Insert Arrangement #22-55 / 23-55

|                 |                                  |                                  |  |                       |                 |                   |
|-----------------|----------------------------------|----------------------------------|--|-----------------------|-----------------|-------------------|
| Connector Type: | JT<br>MIL-DTL-38999<br>Series II | LJT<br>MIL-DTL-38999<br>Series I | Tri-Start<br>MIL-DTL-38999<br>Series III | Number of<br>Contacts | Contact<br>Size | Service<br>Rating |
|                 | 22-55                            | 23-55                            | 23-55                                    |                       |                 |                   |

Contact Locations  
Front face of pin insert shown

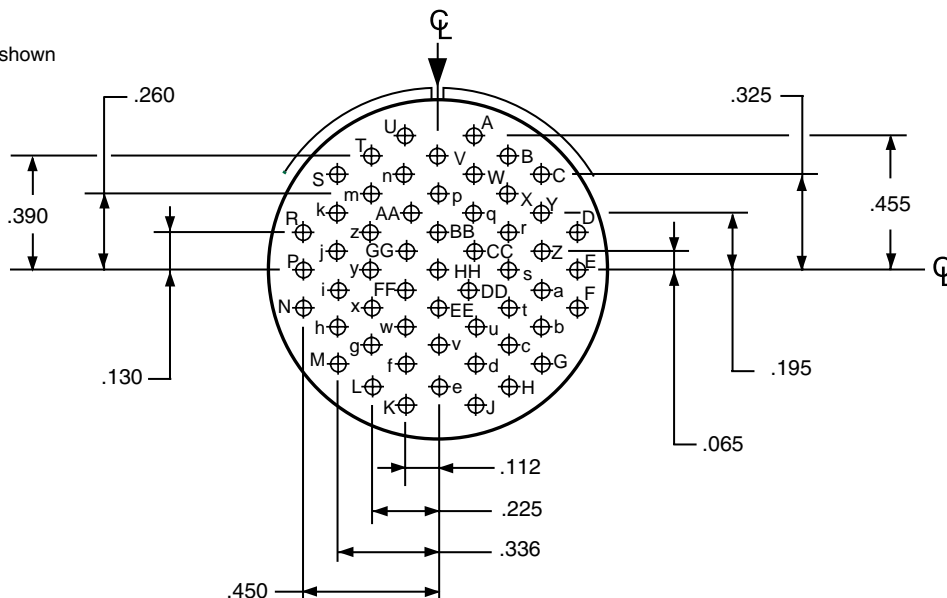

## Insert Arrangement #24-31 / 25-31

|                 |                                  |                                  |  |                       |                 |                   |
|-----------------|----------------------------------|----------------------------------|--|-----------------------|-----------------|-------------------|
| Connector Type: | JT<br>MIL-DTL-38999<br>Series II | LJT<br>MIL-DTL-38999<br>Series I | Tri-Start<br>MIL-DTL-38999<br>Series III | Number of<br>Contacts | Contact<br>Size | Service<br>Rating |
|                 | 24-31                            | NA                               | NA                                       |                       |                 |                   |

Contact Locations  
Front face of pin insert shown

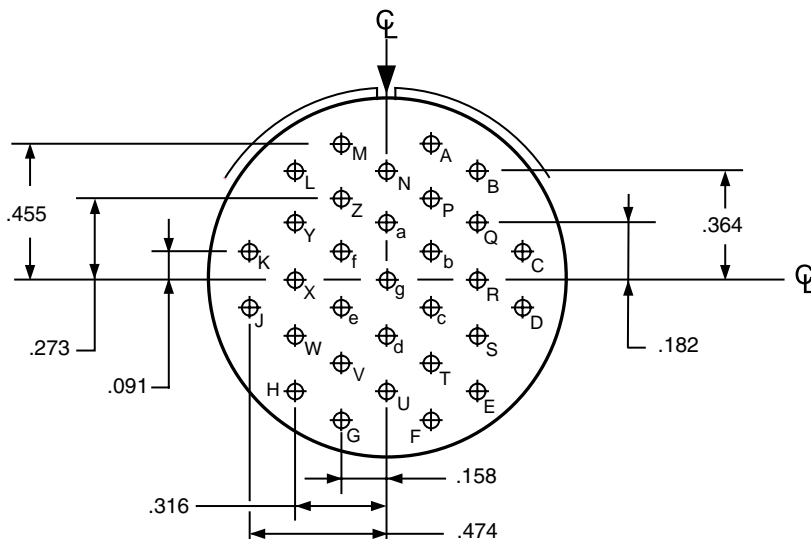

All dimensions for reference only. For alternate rotations see page 240.

Note: Shown in this catalog are the most common insert patterns for PCB applications. For availability of other arrangements, consult Amphenol Corp., Sidney, NY.

38999  
III  
II  
I  
SJT

26482  
Matrix 2

83723 III  
Matrix  
Pyle

5015  
Crimp Rear  
Release Matrix

26500 Pyle

Printed  
Circuit Board

EMI Filter  
Transient

Fiber Optics

High Speed  
Contacts

Options  
Others

### Insert Arrangement #24-35 / 25-35

Connector Type:

|                                  |                                  |  |
|----------------------------------|----------------------------------|--|
| JT<br>MIL-DTL-38999<br>Series II | LJT<br>MIL-DTL-38999<br>Series I | Tri-Start<br>MIL-DTL-38999<br>Series III |
| 24-35                            | 25-35                            | 25-35                                    |

Insert Designation:

| Number of Contacts | Contact Size | Service Rating |
|--------------------|--------------|----------------|
| 128                | 22D          | M              |

#### Contact Locations

Front face of pin insert shown

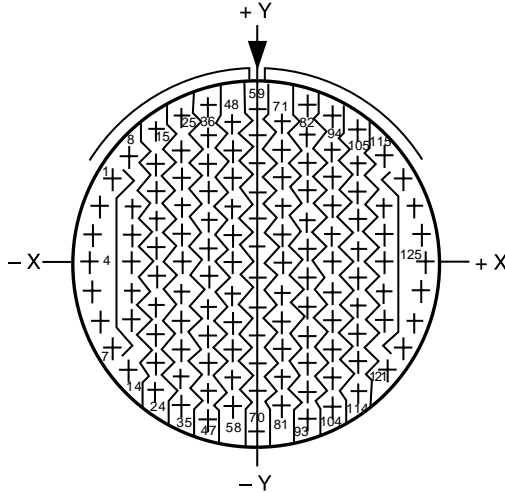

| Contact Number | Location |        |
|----------------|----------|--------|
|                | X Axis   | Y Axis |
| 1              | -.479    | +.279  |
| 2              | -.520    | +.190  |
| 3              | -.546    | +.095  |
| 4              | -.555    | .000   |
| 5              | -.546    | -.095  |
| 6              | -.520    | -.190  |
| 7              | -.479    | -.279  |
| 8              | -.424    | +.357  |
| 9              | -.415    | +.190  |
| 10             | -.415    | +.095  |
| 11             | -.415    | .000   |
| 12             | -.415    | -.095  |
| 13             | -.415    | -.190  |
| 14             | -.424    | -.357  |
| 15             | -.332    | +.444  |
| 16             | -.332    | +.332  |
| 17             | -.332    | +.237  |
| 18             | -.332    | +.142  |
| 19             | -.332    | +.047  |
| 20             | -.332    | -.047  |
| 21             | -.332    | -.142  |
| 22             | -.332    | -.237  |
| 23             | -.332    | -.332  |
| 24             | -.332    | -.427  |
| 25             | -.249    | +.496  |
| 26             | -.249    | +.380  |
| 27             | -.249    | +.285  |
| 28             | -.249    | +.190  |

| Contact Number | Location |        |
|----------------|----------|--------|
|                | X Axis   | Y Axis |
| 29             | -.249    | +.095  |
| 30             | -.249    | .000   |
| 31             | -.249    | -.095  |
| 32             | -.249    | -.190  |
| 33             | -.249    | -.285  |
| 34             | -.249    | -.380  |
| 35             | -.249    | -.475  |
| 36             | -.160    | +.531  |
| 37             | -.166    | +.427  |
| 38             | -.166    | +.332  |
| 39             | -.166    | +.237  |
| 40             | -.166    | +.142  |
| 41             | -.166    | +.047  |
| 42             | -.166    | -.047  |
| 43             | -.166    | -.142  |
| 44             | -.166    | -.237  |
| 45             | -.166    | -.332  |
| 46             | -.166    | -.427  |
| 47             | -.166    | -.522  |
| 48             | -.083    | +.475  |
| 49             | -.083    | +.380  |
| 50             | -.083    | +.285  |
| 51             | -.083    | +.190  |
| 52             | -.083    | +.095  |
| 53             | -.083    | .000   |
| 54             | -.083    | -.095  |
| 55             | -.083    | -.190  |
| 56             | -.083    | -.285  |
| 57             | -.083    | -.380  |
| 58             | -.083    | -.475  |
| 59             | .000     | +.522  |
| 60             | .000     | +.427  |
| 61             | .000     | +.332  |
| 62             | .000     | +.237  |
| 63             | .000     | +.142  |
| 64             | .000     | +.047  |
| 65             | .000     | -.047  |
| 66             | .000     | -.142  |
| 67             | .000     | -.237  |
| 68             | .000     | -.332  |
| 69             | .000     | -.427  |
| 70             | .000     | -.555  |
| 71             | +.083    | +.475  |
| 72             | +.083    | +.380  |
| 73             | +.083    | +.285  |
| 74             | +.083    | +.190  |
| 75             | +.083    | +.095  |
| 76             | +.083    | .000   |
| 77             | +.083    | -.095  |
| 78             | +.083    | -.190  |

| Contact Number | Location |        |
|----------------|----------|--------|
|                | X Axis   | Y Axis |
| 79             | +.083    | -.285  |
| 80             | +.083    | -.380  |
| 81             | +.083    | -.475  |
| 82             | +.160    | +.531  |
| 83             | +.166    | +.427  |
| 84             | +.166    | +.332  |
| 85             | +.166    | +.237  |
| 86             | +.166    | +.142  |
| 87             | +.166    | +.047  |
| 88             | +.166    | -.047  |
| 89             | +.166    | -.142  |
| 90             | +.166    | -.237  |
| 91             | +.166    | -.332  |
| 92             | +.166    | -.427  |
| 93             | +.166    | -.522  |
| 94             | +.249    | +.496  |
| 95             | +.249    | +.380  |
| 96             | +.249    | +.285  |
| 97             | +.249    | +.190  |
| 98             | +.249    | +.095  |
| 99             | +.249    | .000   |
| 100            | +.249    | -.095  |
| 101            | +.249    | -.190  |
| 102            | +.249    | -.285  |
| 103            | +.249    | -.380  |
| 104            | +.249    | -.475  |
| 105            | +.332    | +.444  |
| 106            | +.332    | +.332  |
| 107            | +.332    | +.237  |
| 108            | +.332    | +.142  |
| 109            | +.332    | +.047  |
| 110            | +.332    | -.047  |
| 111            | +.332    | -.142  |
| 112            | +.332    | -.237  |
| 113            | +.332    | -.332  |
| 114            | +.332    | -.427  |
| 115            | +.424    | +.357  |
| 116            | +.415    | +.190  |
| 117            | +.415    | +.095  |
| 118            | +.415    | .000   |
| 119            | +.415    | -.095  |
| 120            | +.415    | -.190  |
| 121            | +.424    | -.357  |
| 122            | +.479    | +.279  |
| 123            | +.520    | +.190  |
| 124            | +.546    | +.095  |
| 125            | +.555    | .000   |
| 126            | +.546    | -.095  |
| 127            | +.520    | -.190  |
| 128            | +.479    | -.279  |

All dimensions for reference only. For alternate rotations see page 240.

Note: Shown in this catalog are the most common insert patterns for PCB applications. For availability of other arrangements, consult Amphenol Corp., Sidney, NY.



# Circular Connectors – PCB Contacts Insert Arrangements

## Insert Arrangement #24-61 / 25-61

|                 |                                  |                                  |  |
|-----------------|----------------------------------|----------------------------------|--|
| Connector Type: | JT<br>MIL-DTL-38999<br>Series II | LJT<br>MIL-DTL-38999<br>Series I | Tri-Start<br>MIL-DTL-38999<br>Series III |
|                 | 24-61                            | 25-61                            | 25-61                                    |

|                    |              |                |
|--------------------|--------------|----------------|
| Number of Contacts | Contact Size | Service Rating |
| 61                 | 20           | I              |

**Contact Locations**  
Front face of pin insert shown

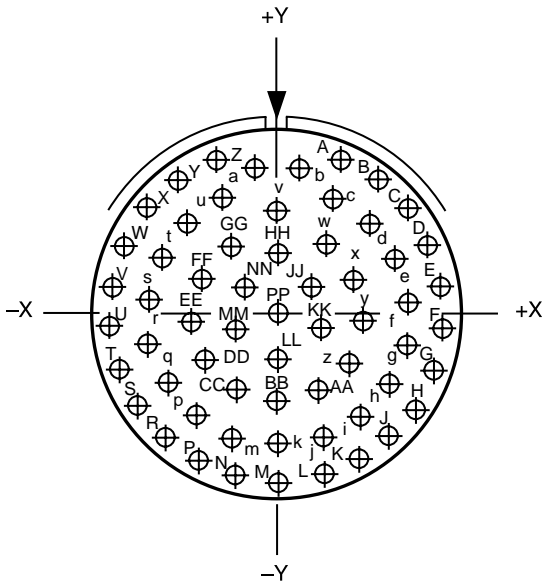

| Contact Number | Location |        |
|----------------|----------|--------|
|                | X Axis   | Y Axis |
| A              | +.196    | +.500  |
| B              | +.314    | +.435  |
| C              | +.413    | +.343  |
| D              | +.485    | +.230  |
| E              | +.527    | +.101  |
| F              | +.536    | -.030  |
| G              | +.511    | -.164  |
| H              | +.454    | -.287  |
| J              | +.368    | -.391  |
| K              | +.259    | -.470  |
| L              | +.134    | -.519  |
| M              | .000     | -.537  |
| N              | -.134    | -.519  |
| P              | -.259    | -.470  |
| R              | -.368    | -.391  |
| S              | -.454    | -.287  |
| T              | -.511    | -.164  |
| U              | -.536    | -.030  |
| V              | -.527    | +.101  |
| W              | -.485    | +.230  |
| X              | -.413    | +.343  |
| Y              | -.314    | +.435  |
| Z              | -.196    | +.500  |
| a              | -.068    | +.454  |
| b              | +.068    | +.454  |
| c              | +.173    | +.363  |
| d              | +.285    | +.283  |
| e              | +.362    | +.175  |
| f              | +.399    | +.046  |

| Contact Number | Location |        |
|----------------|----------|--------|
|                | X Axis   | Y Axis |
| g              | +.392    | -.088  |
| h              | +.341    | -.213  |
| i              | +.251    | -.314  |
| j              | +.133    | -.379  |
| k              | .000     | -.402  |
| m              | -.133    | -.379  |
| n              | -.251    | -.314  |
| p              | -.341    | -.213  |
| q              | -.392    | -.088  |
| r              | -.399    | +.046  |
| s              | -.362    | +.175  |
| t              | -.285    | +.283  |
| u              | -.173    | +.363  |
| v              | .000     | +.338  |
| w              | +.147    | +.223  |
| x              | +.237    | +.122  |
| y              | +.267    | -.010  |
| z              | +.228    | -.139  |
| AA             | +.131    | -.233  |
| BB             | .000     | -.267  |
| CC             | -.131    | -.233  |
| DD             | -.228    | -.139  |
| EE             | -.267    | -.010  |
| FF             | -.237    | +.122  |
| GG             | -.147    | +.223  |
| HH             | .000     | +.200  |
| JJ             | +.105    | +.094  |
| KK             | +.135    | -.041  |
| LL             | .000     | -.132  |
| MM             | -.135    | -.041  |
| NN             | -.105    | +.094  |
| PP             | .000     | .000   |

All dimensions for reference only. For alternate rotations see page 240.

Note: Shown in this catalog are the most common insert patterns for PCB applications. For availability of other arrangements, consult Amphenol Corp., Sidney, NY.

- III 38999
- II
- I
- SJT
- 26482 Matrix 2
- 83723 III Matrix Pyle
- 5015 Crimp Rear Release Matrix
- 26500 Pyle
- Printed Circuit Board
- EMI Filter Transient
- Fiber Optics
- High Speed Contacts
- Options Others

### Series III TV

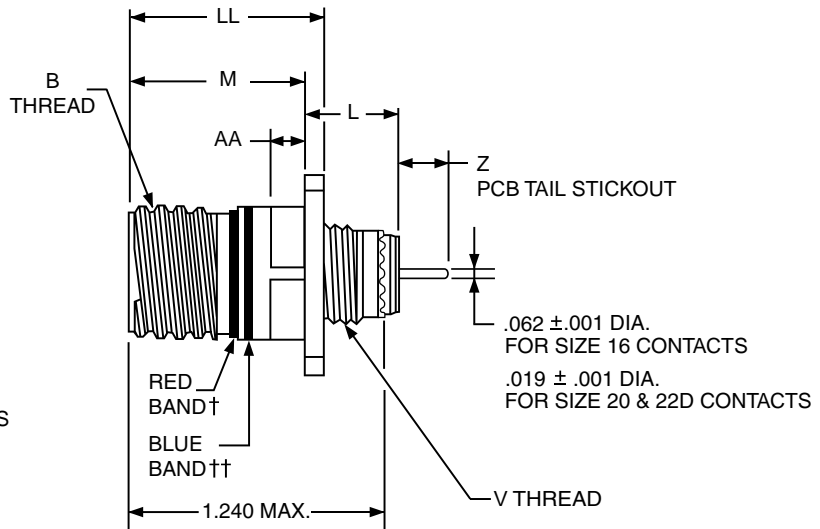
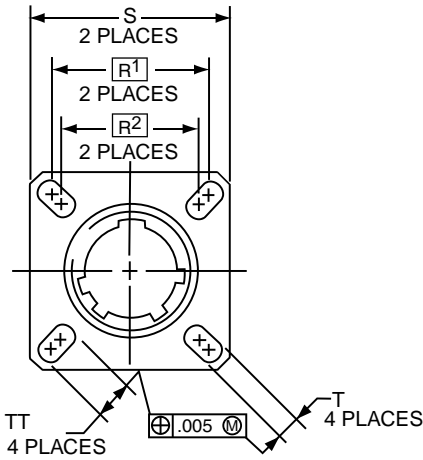

1. 2. 3. 4. 5.

| PART #          | Shell Finish | Base Number | Coded Shell Size | Insert Arrangement | Contact Type/Alt. Keying Positions |
|-----------------|--------------|-------------|------------------|--------------------|------------------------------------|
| See chart below | 88/91        | 569         | 76X              | -35                | P                                  |

### HOW TO ORDER

#### 1. Select a Shell Finish:

|    |  |
|----|--|
| 88 | Designates olive drab cadmium plated connector shell |
| 91 | Designates electroless nickel plated connector shell |

#### 4. Select an Insert Arrangement:

Refer to insert availability chart on page 239 and pin-out illustrations on pages 241-255. In the chart the first number represents the Shell size and the second number is the insert Arrangement.

|     |                                      |
|-----|--------------------------------------|
| -35 | Designates Insert Arrangement Number |
|-----|--------------------------------------|

#### 2. Base Number:

|     |             |
|-----|-------------|
| 569 | Base Number |
|-----|-------------|

#### 5. Contact Type/Alternate Keying Positions:

Refer to page 240 for alternate rotation letters to use.

|   |   |
|---|---|
| P | Designates Pin Contacts in Normal Position    |
| S | Designates Socket Contacts in Normal Position |

#### 3. Select a Coded Shell Size:

See chart below 761-769, designates size 9-25 shell size.  
Example: 761= Size 9 Shell

| Shell Size | Part Number      | BThread Class 2A (Plated) 0.1P-0.3L-TS | L Max. | M +.000 - .005 | R <sup>1</sup> | R <sup>2</sup> | S Max. | T +.008 - .006 | V Thread Metric | AA Max. Panel Thickness | LL +.006 - .000 | TT +.008 - .006 | Z                     |                   |
|------------|------------------|--|--------|----------------|----------------|----------------|--------|----------------|-----------------|-------------------------|-----------------|-----------------|-----------------------|-------------------|
|            |                  |  |        |                |                |                |        |                |                 |                         |                 |                 | Size 16 & 20 Contacts | Size 22D Contacts |
| 9          | 88/91-569761-XXX | .6250                                  | .469   | .820           | .719           | .594           | .948   | .128           | M12X1-6g        | .234                    | .905            | .216            | .228-.178             | .242-.181         |
| 11         | 762-XXX          | .7500                                  | .469   | .820           | .812           | .719           | 1.043  | .128           | M15X1-6g        | .234                    | .905            | .194            | .228-.178             | .242-.181         |
| 13         | 763-XXX          | .8750                                  | .469   | .820           | .906           | .812           | 1.137  | .128           | M18X1-6g        | .234                    | .905            | .194            | .228-.178             | .242-.181         |
| 15         | 764-XXX          | 1.0000                                 | .469   | .820           | .969           | .906           | 1.232  | .128           | M22X1-6g        | .234                    | .905            | .173            | .228-.178             | .242-.181         |
| 17         | 765-XXX          | 1.1875                                 | .469   | .820           | 1.062          | .969           | 1.323  | .128           | M25X1-6g        | .234                    | .905            | .194            | .228-.178             | .242-.181         |
| 19         | 766-XXX          | 1.2500                                 | .469   | .820           | 1.156          | 1.062          | 1.449  | .128           | M28X1-6g        | .234                    | .905            | .194            | .228-.178             | .242-.181         |
| 21         | 767-XXX          | 1.3750                                 | .500   | .790           | 1.250          | 1.156          | 1.575  | .128           | M31X1-6g        | .204                    | .905            | .194            | .228-.178             | .242-.181         |
| 23         | 768-XXX          | 1.5000                                 | .500   | .790           | 1.375          | 1.250          | 1.701  | .154           | M34X1-6g        | .204                    | .905            | .242            | .228-.178             | .242-.181         |
| 25         | 769-XXX          | 1.6250                                 | .500   | .790           | 1.500          | 1.375          | 1.823  | .154           | M37X1-6g        | .204                    | .905            | .242            | .228-.178             | .242-.181         |

All dimensions for reference only.

Composite Series III connectors with PBC Contacts are available; consult Amphenol, Sidney, NY.

Z dimension is determined by contact type in the insert arrangement.

Most common options are shown; other options are available.

□ Designates true position dimensioning

† Red band indicates fully mated

†† Blue band indicates rear release contact retention system

# 38999, Series III with PCB Contacts TVP00R Wall Mounting Receptacle

(Back Panel Mounting) (With Clinch Nuts)

Series III TV

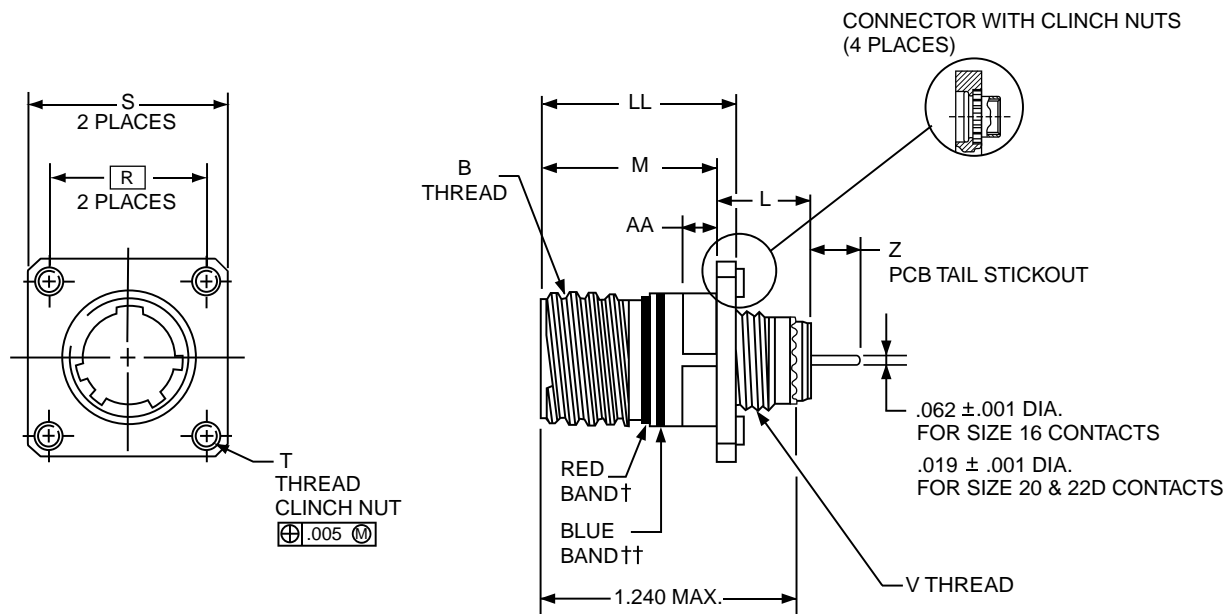

| PART #          | 1. Shell Finish | 2. Base Number | 3. Coded Shell Size | 4. Insert Arrangement | 5. Contact Type/Alt. Keying Positions |
|-----------------|-----------------|----------------|---------------------|-----------------------|---------------------------------------|
| See chart below | 88/91           | 628            | 74                  | -35                   | P                                     |

## HOW TO ORDER

### 1. Select a Shell Finish:

|    |  |
|----|--|
| 88 | Designates olive drab cadmium plated connector shell |
| 91 | Designates electroless nickel plated connector shell |

### 2. Base Number:

|     |             |
|-----|-------------|
| 628 | Base Number |
|-----|-------------|

### 3. Select a Coded Shell Size:

See chart below **741-749**, designates size 9-25 shell size.  
Example: **741**= Size 9 Shell

| Shell Size | Part Number with Clinch Nuts* | B Thread Class 2A (Plated) 0.1P-0.3L-TS | L Max. | M +.000 - .005 | R     | S Max. | T Thread      | V Thread Metric | AA Max. Panel Thickness | LL +.006 - .000 | Z                     |                   |
|------------|-------------------------------|---|--------|----------------|-------|--------|---------------|-----------------|-------------------------|-----------------|-----------------------|-------------------|
|            |                               |   |        |                |       |        |               |                 |                         |                 | Size 16 & 20 Contacts | Size 22D Contacts |
| 9          | 88/91-628 <b>741</b> -XXX     | .6250                                   | .469   | .820           | .719  | 1.094  | .112-40UNC-3B | M12X1-6g        | .234                    | .905            | .228-.178             | .242-.181         |
| 11         | <b>742</b> -XXX               | .7500                                   | .469   | .820           | .812  | 1.187  | .112-40UNC-3B | M15X1-6g        | .234                    | .905            | .228-.178             | .242-.181         |
| 13         | <b>743</b> -XXX               | .8750                                   | .469   | .820           | .906  | 1.281  | .112-40UNC-3B | M18X1-6g        | .234                    | .905            | .228-.178             | .242-.181         |
| 15         | <b>744</b> -XXX               | 1.0000                                  | .469   | .820           | .969  | 1.344  | .112-40UNC-3B | M22X1-6g        | .234                    | .905            | .228-.178             | .242-.181         |
| 17         | <b>745</b> -XXX               | 1.1875                                  | .469   | .820           | 1.062 | 1.437  | .112-40UNC-3B | M25X1-6g        | .234                    | .905            | .228-.178             | .242-.181         |
| 19         | <b>746</b> -XXX               | 1.2500                                  | .469   | .820           | 1.156 | 1.531  | .112-40UNC-3B | M28X1-6g        | .234                    | .905            | .228-.178             | .242-.181         |
| 21         | <b>747</b> -XXX               | 1.3750                                  | .500   | .790           | 1.250 | 1.625  | .112-40UNC-3B | M31X1-6g        | .204                    | .905            | .228-.178             | .242-.181         |
| 23         | <b>748</b> -XXX               | 1.5000                                  | .500   | .790           | 1.375 | 1.750  | .138-32UNC-3B | M34X1-6g        | .204                    | .905            | .228-.178             | .242-.181         |
| 25         | <b>749</b> -XXX               | 1.6250                                  | .500   | .790           | 1.500 | 1.875  | .138-32UNC-3B | M37X1-6g        | .204                    | .905            | .228-.178             | .242-.181         |

All dimensions for reference only.

\*Consult Amphenol for more information on ordering connectors with clinch nuts.

Composite Series III connectors with PBC Contacts are available; consult Amphenol, Sidney, NY.

Z dimension is determined by contact type in the insert arrangement.

Most common options are shown; other options are available.

Designates true position dimensioning

† Red band indicates fully mated

†† Blue band indicates rear release contact retention system

III  
II  
I  
SJT  
38999

Matrix 2  
26482

Matrix Pyle  
83723 III

Release Matrix  
5015  
Crimp Rear

26500 Pyle

Printed  
Circuit Board

EM I Filter  
Transient

Fiber Optics

High Speed  
Contacts

Options  
Others

### Series III TV

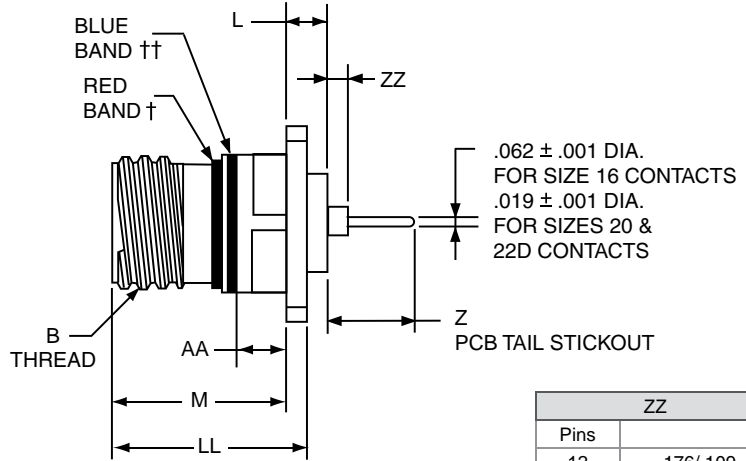
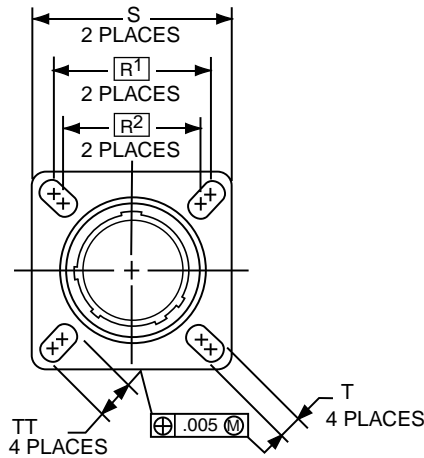

| ZZ      |            |
|---------|------------|
| Pins    |            |
| 12      | .176/.109  |
| 16      | .044/-.013 |
| 20      | .161/.094  |
| 22D     | .092/.025  |
| Sockets |            |
| 12      | .176/.109  |
| 16      | .092/.035  |
| 20      | .161/.094  |
| 22D     | .159/.088  |

| PART #          | 1. Shell Finish | 2. Base Number | 3. Coded Shell Size | 4. Insert Arrangement | 5. Contact Type/Alt. Keying Positions |
|-----------------|-----------------|----------------|---------------------|-----------------------|---------------------------------------|
| See chart below | 88/91           | 569            | 771                 | -35                   | P                                     |

### HOW TO ORDER

#### 1. Select a Shell Finish:

|    |  |
|----|--|
| 88 | Designates olive drab cadmium plated connector shell |
| 91 | Designates electroless nickel plated connector shell |

#### 2. Base Number:

|     |             |
|-----|-------------|
| 569 | Base Number |
|-----|-------------|

#### 3. Select a Coded Shell Size:

See chart below **771-779**, designates size 9-25 shell size.  
Example: **771**= Size 9 Shell

#### 4. Select an Insert Arrangement:

Refer to insert availability chart on page 239 and pin-out illustrations on pages 241-255. In the chart the first number represents the Shell size and the second number is the insert Arrangement.

|     |                                      |
|-----|--------------------------------------|
| -35 | Designates Insert Arrangement Number |
|-----|--------------------------------------|

#### 5. Contact Type/Alternate Keying Positions:

Refer to page 240 for alternate rotation letters to use.

|   |   |
|---|---|
| P | Designates Pin Contacts in Normal Position    |
| S | Designates Socket Contacts in Normal Position |

| Shell Size | Part Number               | BThread Class 2A (Plated) 0.1P-0.3L-TS | L Max. | M +.000 - .005 | R <sup>1</sup> | R <sup>2</sup> | S Max. | T +.008 - .006 | AA Max. Panel Thickness | LL +.006 - .000 | TT +.008 - .006 | Z                     |                   |
|------------|---------------------------|--|--------|----------------|----------------|----------------|--------|----------------|-------------------------|-----------------|-----------------|-----------------------|-------------------|
|            |                           |  |        |                |                |                |        |                |                         |                 |                 | Size 16 & 20 Contacts | Size 22D Contacts |
| 9          | 88/91-569 <b>771</b> -XXX | .6250                                  | .205   | .820           | .719           | .594           | .948   | .128           | .234                    | .905            | .216            | .460-.375             | .471-.399         |
| 11         | <b>772</b> -XXX           | .7500                                  | .205   | .820           | .812           | .719           | 1.043  | .128           | .234                    | .905            | .194            | .460-.375             | .471-.399         |
| 13         | <b>773</b> -XXX           | .8750                                  | .205   | .820           | .906           | .812           | 1.137  | .128           | .234                    | .905            | .194            | .460-.375             | .471-.399         |
| 15         | <b>774</b> -XXX           | 1.0000                                 | .205   | .820           | .969           | .906           | 1.232  | .128           | .234                    | .905            | .173            | .460-.375             | .471-.399         |
| 17         | <b>775</b> -XXX           | 1.1875                                 | .205   | .820           | 1.062          | .969           | 1.323  | .128           | .234                    | .905            | .194            | .460-.375             | .471-.399         |
| 19         | <b>776</b> -XXX           | 1.2500                                 | .205   | .820           | 1.156          | 1.062          | 1.449  | .128           | .234                    | .905            | .194            | .460-.375             | .471-.399         |
| 21         | <b>777</b> -XXX           | 1.3750                                 | .235   | .790           | 1.250          | 1.156          | 1.575  | .128           | .204                    | .905            | .194            | .460-.375             | .471-.399         |
| 23         | <b>778</b> -XXX           | 1.5000                                 | .235   | .790           | 1.375          | 1.250          | 1.701  | .154           | .204                    | .905            | .242            | .460-.375             | .471-.399         |
| 25         | <b>779</b> -XXX           | 1.6250                                 | .235   | .790           | 1.500          | 1.375          | 1.823  | .154           | .204                    | .905            | .242            | .460-.375             | .471-.399         |

All dimensions for reference only.

Composite Series III connectors with PBC Contacts are available; consult Amphenol, Sidney, NY. Z dimension is determined by contact type in the insert arrangement.

Most common options are shown; other options are available.

□ Designates true position dimensioning  
† Red band indicates fully mated  
†† Blue band indicates rear release contact retention system

# 38999, Series III with PCB Contacts TVP02R Box Mounting Receptacle

(With Clinch Nuts)

Series III TV

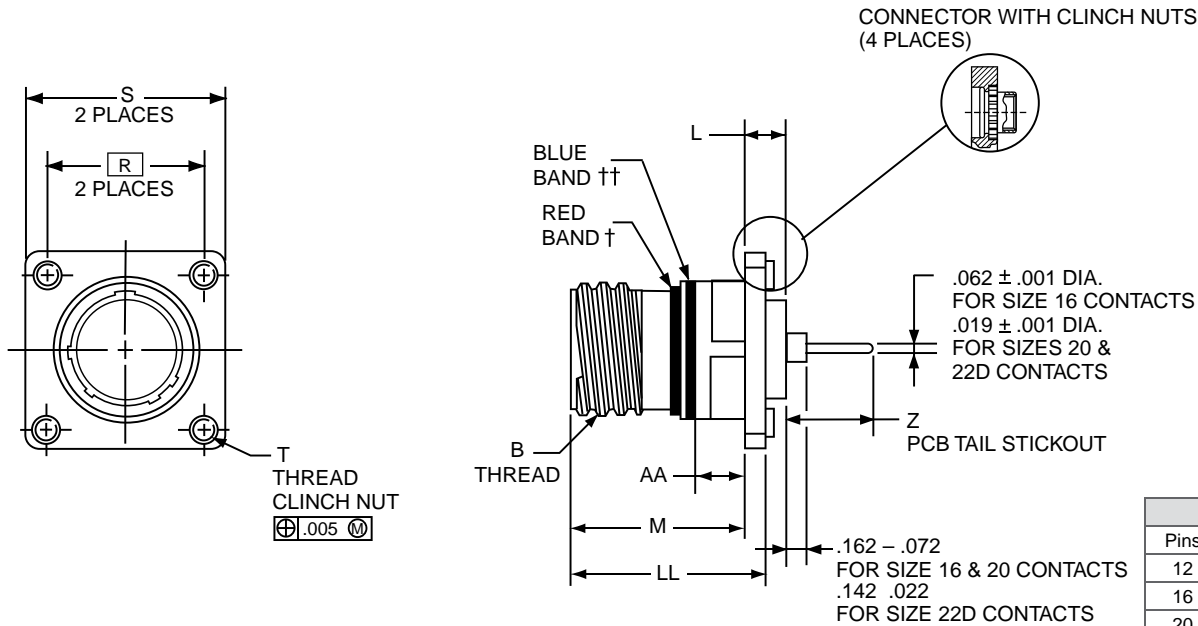

| PART #          | 1. Shell Finish | 2. Base Number | 3. Coded Shell Size | 4. Insert Arrangement | 5. Contact Type/Alt. Keying Positions |
|-----------------|-----------------|----------------|---------------------|-----------------------|---------------------------------------|
| See chart below | 88/91           | 628            | 75                  | -35                   | P                                     |

| ZZ     |            |
|--------|------------|
| Pins   |            |
| 12     | .176/.109  |
| 16     | .044/-.013 |
| 20     | .161/.094  |
| 22D    | .092/.025  |
| Socket |            |
| 12     | .176/.109  |
| 16     | .092/.035  |
| 20     | .161/.094  |
| 22D    | .159/.088  |

## HOW TO ORDER

### 1. Select a Shell Finish:

|    |  |
|----|--|
| 88 | Designates olive drab cadmium plated connector shell |
| 91 | Designates electroless nickel plated connector shell |

### 2. Base Number:

|     |             |
|-----|-------------|
| 628 | Base Number |
|-----|-------------|

### 3. Select a Coded Shell Size:

See chart below 751-759, designates size 9-25 shell size.  
Example: 751= Size 9 Shell

| Shell Size | Part Number with Clinch Nuts* | B Thread Class 2A (Plated) 0.1P-0.3L-TS | L Max. | M +.000 - .005 | R     | S Max. | T Thread      | AA Max. Panel Thickness | LL +.006 - .000 | Z                     |                   |
|------------|-------------------------------|---|--------|----------------|-------|--------|---------------|-------------------------|-----------------|-----------------------|-------------------|
|            |                               |   |        |                |       |        |               |                         |                 | Size 16 & 20 Contacts | Size 22D Contacts |
| 9          | 88/91-628751-XXX              | .6250                                   | .205   | .820           | .719  | 1.031  | .112-40UNC-3B | .234                    | .905            | .460-.375             | .471-.399         |
| 11         | 752-XXX                       | .7500                                   | .205   | .820           | .812  | 1.125  | .112-40UNC-3B | .234                    | .905            | .460-.375             | .471-.399         |
| 13         | 753-XXX                       | .8750                                   | .205   | .820           | .906  | 1.172  | .112-40UNC-3B | .234                    | .905            | .460-.375             | .471-.399         |
| 15         | 754-XXX                       | 1.0000                                  | .205   | .820           | .969  | 1.281  | .112-40UNC-3B | .234                    | .905            | .460-.375             | .471-.399         |
| 17         | 755-XXX                       | 1.1875                                  | .205   | .820           | 1.062 | 1.375  | .112-40UNC-3B | .234                    | .905            | .460-.375             | .471-.399         |
| 19         | 756-XXX                       | 1.2500                                  | .205   | .820           | 1.156 | 1.469  | .112-40UNC-3B | .234                    | .905            | .460-.375             | .471-.399         |
| 21         | 757-XXX                       | 1.3750                                  | .235   | .790           | 1.250 | 1.562  | .112-40UNC-3B | .204                    | .905            | .460-.375             | .471-.399         |
| 23         | 758-XXX                       | 1.5000                                  | .235   | .790           | 1.375 | 1.750  | .112-40UNC-3B | .204                    | .905            | .460-.375             | .471-.399         |
| 25         | 759-XXX                       | 1.6250                                  | .235   | .790           | 1.500 | 1.875  | .112-40UNC-3B | .204                    | .905            | .460-.375             | .471-.399         |

All dimensions for reference only.

\* Consult Amphenol for more information on ordering connectors with clinch nuts.  
Composite Series III connectors with PCB Contacts are available; consult Amphenol, Sidney, NY.

• Z dimension is determined by contact type in the insert arrangement.  
• Most common options are shown; other options are available.

□ Designates true position dimensioning  
† Red band indicates fully mated  
†† Blue band indicates rear release contact retention system

III  
II  
I  
SJT  
38999

Matrix 2  
26482

Matrix Pyle  
83723 III

Release Matrix  
5015  
Crimp Rear

26500 Pyle

Printed  
Circuit Board

EMI Filter  
Transient

Fiber Optics

High Speed  
Contacts

Options  
Others

### Series III TV

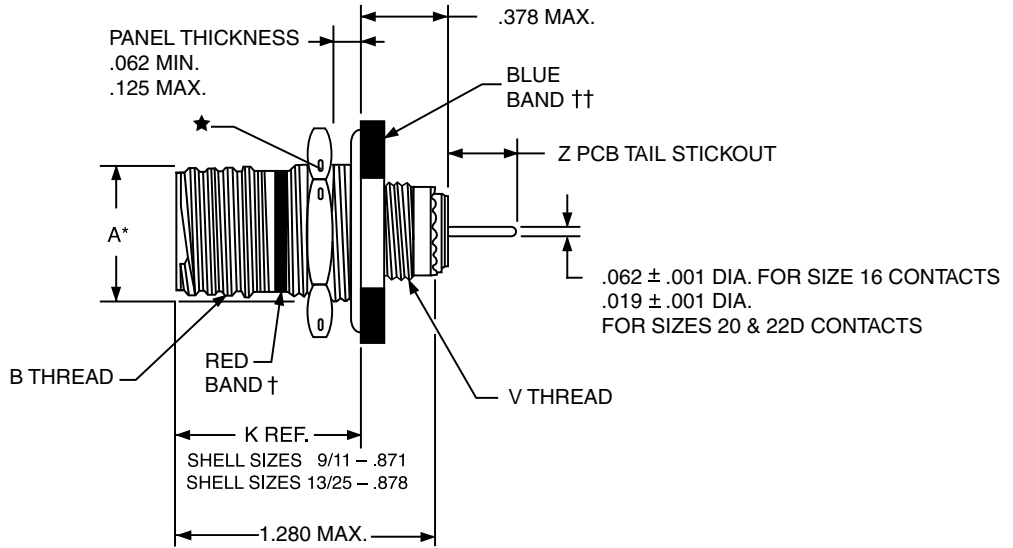
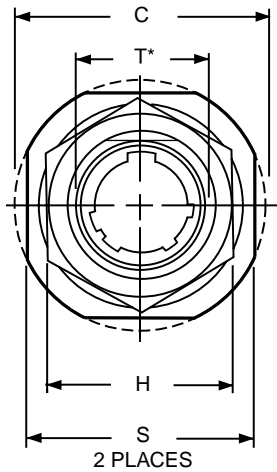

| PART #          | Shell Finish | Base Number | Coded Shell Size | Insert Arrangement | Contact Type/Alt. Keying Positions |
|-----------------|--------------|-------------|------------------|--------------------|------------------------------------|
| See chart below | 88/91        | 569         | 781              | -35                | P                                  |

### HOW TO ORDER

#### 1. Select a Shell Finish:

|    |  |
|----|--|
| 88 | Designates olive drab cadmium plated connector shell |
| 91 | Designates electroless nickel plated connector shell |

#### 2. Base Number:

|     |             |
|-----|-------------|
| 569 | Base Number |
|-----|-------------|

#### 3. Select a Coded Shell Size:

See chart below **781-789**, designates size 9-25 shell size.  
Example: **781**= Size 9 Shell

| Shell Size | Part Number               | A*<br>+.000<br>-.010 | B Thread<br>Class 2A (Plated)<br>0.1P-0.3L-TS | C<br>Max. | H Hex<br>+.017<br>-.016 | S<br>±.010 | T<br>+.010<br>-.000 | V Thread<br>Metric | Z                        |                      |
|------------|---------------------------|----------------------|---|-----------|-------------------------|------------|---------------------|--------------------|--------------------------|----------------------|
|            |                           |                      |   |           |                         |            |                     |                    | Size 16 & 20<br>Contacts | Size 22D<br>Contacts |
| 9          | 88/91-569 <b>781</b> -XXX | .669                 | .6250   | 1.199     | .875                    | 1.062      | .697                | M12X1-6g           | .244 - .200              | .258 - .206          |
| 11         | <b>782</b> -XXX           | .769                 | .7500   | 1.386     | 1.000                   | 1.250      | .822                | M15X1-6g           | .244 - .200              | .258 - .206          |
| 13         | <b>783</b> -XXX           | .955                 | .8750   | 1.511     | 1.188                   | 1.375      | 1.007               | M18X1-6g           | .244 - .200              | .258 - .206          |
| 15         | <b>784</b> -XXX           | 1.084                | 1.0000  | 1.636     | 1.312                   | 1.500      | 1.134               | M22X1-6g           | .244 - .200              | .258 - .206          |
| 17         | <b>785</b> -XXX           | 1.208                | 1.1875  | 1.761     | 1.438                   | 1.625      | 1.259               | M25X1-6g           | .244 - .200              | .258 - .206          |
| 19         | <b>786</b> -XXX           | 1.333                | 1.2500  | 1.949     | 1.562                   | 1.812      | 1.384               | M28X1-6g           | .222 - .177              | .236 - .180          |
| 21         | <b>787</b> -XXX           | 1.459                | 1.3750  | 2.073     | 1.688                   | 1.938      | 1.507               | M31X1-6g           | .222 - .177              | .236 - .180          |
| 23         | <b>788</b> -XXX           | 1.575                | 1.5000  | 2.199     | 1.812                   | 2.062      | 1.634               | M34X1-6g           | .222 - .177              | .236 - .180          |
| 25         | <b>789</b> -XXX           | 1.709                | 1.6250  | 2.323     | 2.000                   | 2.188      | 1.759               | M37X1-6g           | .222 - .177              | .236 - .180          |

#### 4. Select an Insert Arrangement:

Refer to insert availability chart on page 239 and pin-out illustrations on pages 241-255. In the chart the first number represents the Shell size and the second number is the insert Arrangement.

|     |                                      |
|-----|--------------------------------------|
| -35 | Designates Insert Arrangement Number |
|-----|--------------------------------------|

#### 5. Contact Type/Alternate Keying Positions:

Refer to page 240 for alternate rotation letters to use.

|   |   |
|---|---|
| P | Designates Pin Contacts in Normal Position    |
| S | Designates Socket Contacts in Normal Position |

All dimensions for reference only.  
Composite Series III connectors with PBC Contacts are available; consult Amphenol, Sidney, NY.  
Z dimension is determined by contact type in the insert arrangement.  
Most common options are shown; other options are available.

† Red band indicates fully mated  
†† Blue band indicates rear release contact retention system  
★ .059 dia. min. 3 lockwire holes. Formed lockwire hole design (6 holes) is optional.  
\* "D" shaped mounting hole dimensions



# 38999, Series III Hermetic - PCB Contacts TVS07Y Jam Nut Receptacle

Series III TV

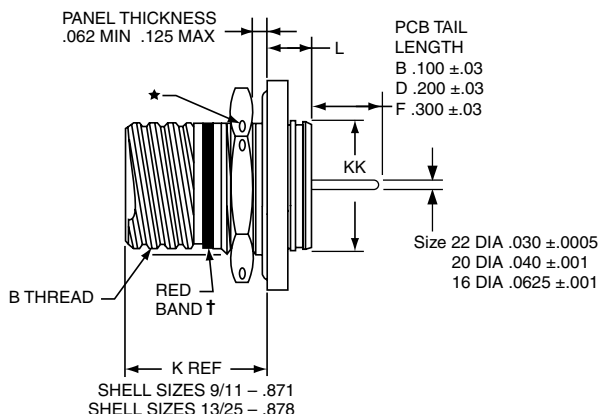
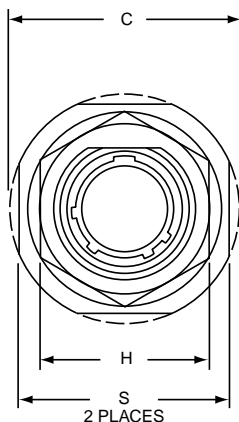

### PANEL HOLE DIMENSIONS

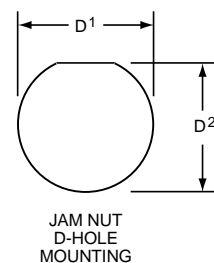

PCB TAIL LENGTH  
B .100 ±.03  
D .200 ±.03  
F .300 ±.03

Size 22 DIA .030 ±.0005  
20 DIA .040 ±.001  
16 DIA .0625 ±.001

- 1.
- 2.
- 3.
- 4.
- 5.
- 6.

### PART #

See chart below

| Base Number | Coded Shell Size | Insert Arrg. | Contact Type/Alt. Keying Positions | Shell Finish | Tail Length |
|-------------|------------------|--------------|------------------------------------|--------------|-------------|
| 10-626      | 471              | -35          | P                                  | 1            | B           |

## HOW TO ORDER

### 1. Base Number:

**10-626** Base Number for MIL-DTL-38999 Series III Hermetic with PCB Tail

### 5. Select a Shell Finish:

- 1 Hermetic seal, passivated Stainless Steel, 200°C
- 2 Hermetic seal, Stainless Steel w/Nickel Plate

### 2. Select a Coded Shell Size:

See chart below **471-479**, designates size 9-25 shell size

### 6. Select a Tail Length:

- |   |          |
|---|----------|
| B | .100±.03 |
| D | .200±.03 |
| F | .300±.03 |

### 3. Select an Insert Arrangement:

Refer to insert availability chart on page 239 and pin-out illustrations on pages 241-255. In the chart the first number represents the Shell size and the second number is the insert Arrangement.

**-35** Designates Insert Arrangement Number

### 4. Contact Type/Alternate Keying Positions:

Refer to page 240 for alternate rotation letters to use.

|          |   |
|----------|---|
| <b>P</b> | Designates Pin Contacts in Normal Position    |
| <b>S</b> | Designates Socket Contacts in Normal Position |

† Red band indicates fully mated

★ .059 dia min.

1.5 dia min.

3 lockwire holes

Formed lockwire hole design (6 holes) is optional.

| Shell Size | Part Number   | B Thread Class 2A 0.1P-0.3L-TS (Plated) | C Max | D1 +.010 - .000 | D2 +.000 - .010 | H Hex +.017 - .016 | L Max | S ±.010 | KK +.011 - .000 |
|------------|---------------|---|-------|-----------------|-----------------|--------------------|-------|---------|-----------------|
| 9          | 10-626471-XXX | .6250                                   | 1.199 | .700            | .670            | .875               | .357  | 1.062   | .642            |
| 11         | 472-XXX       | .7500                                   | 1.386 | .825            | .770            | 1.000              | .357  | 1.250   | .766            |
| 13         | 473-XXX       | .8750                                   | 1.511 | 1.010           | .955            | 1.188              | .357  | 1.375   | .892            |
| 15         | 474-XXX       | 1.0000                                  | 1.636 | 1.135           | 1.085           | 1.312              | .357  | 1.500   | 1.018           |
| 17         | 475-XXX       | 1.1875                                  | 1.761 | 1.260           | 1.210           | 1.438              | .357  | 1.625   | 1.142           |
| 19         | 476-XXX       | 1.2500                                  | 1.949 | 1.385           | 1.335           | 1.562              | .381  | 1.812   | 1.268           |
| 21         | 477-XXX       | 1.3750                                  | 2.073 | 1.510           | 1.460           | 1.688              | .381  | 1.938   | 1.392           |
| 23         | 478-XXX       | 1.5000                                  | 2.199 | 1.635           | 1.585           | 1.812              | .381  | 2.062   | 1.518           |
| 25         | 479-XXX       | 1.6250                                  | 2.323 | 1.760           | 1.710           | 2.000              | .381  | 2.188   | 1.642           |

All dimensions for reference only.

III  
II  
I  
SJT  
38999

Matrix 2  
26482

Matrix  
Pyle  
83723 III

Release Matrix  
Crimp Rear  
5015

26500 Pyle

Printed  
Circuit Board

EM I Filter  
Transient

Fiber Optics

High Speed  
Contacts

Options  
Others

**Solder Mounting Receptacle**

**Series III TV**

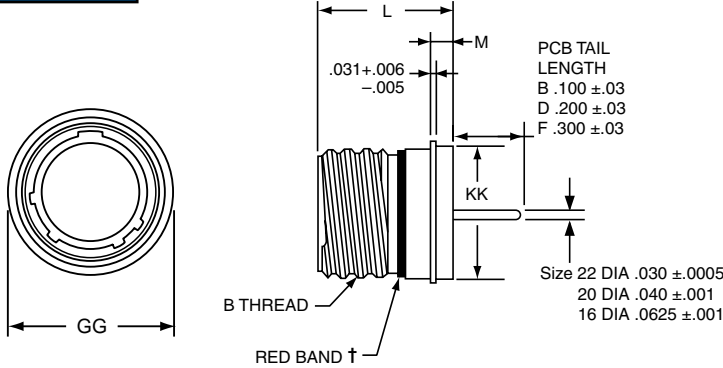

**PART #**  
See chart below

| 1.          | 2.         | 3.           | 4.                                 | 5.           | 6.          |
|-------------|------------|--------------|------------------------------------|--------------|-------------|
| Base Number | Shell Size | Insert Arrg. | Contact Type/Alt. Keying Positions | Shell Finish | Tail Length |
| 10-626      | 481        | -35          | P                                  | 1            | B           |

Follow HOW TO ORDER instructions below.

† Red band indicates fully mated

| Shell Size | Part Number   | B Thread Class 2A 0.1P-0.3L-TS (Plated) | L +.011 - .005 | M +.006 - .005 | GG Dia. +.011 - .010 | KK Dia +.011 - .005 |
|------------|---------------|---|----------------|----------------|----------------------|---------------------|
| 9          | 10-626481-XXX | .6250                                   | .806           | .125           | .750                 | .672                |
| 11         | 482-XXX       | .7500                                   | .806           | .125           | .844                 | .781                |
| 13         | 483-XXX       | .8750                                   | .806           | .125           | .969                 | .906                |
| 15         | 484-XXX       | 1.0000                                  | .806           | .125           | 1.094                | 1.031               |
| 17         | 485-XXX       | 1.1875                                  | .806           | .125           | 1.218                | 1.156               |
| 19         | 486-XXX       | 1.2500                                  | .806           | .125           | 1.312                | 1.250               |
| 21         | 487-XXX       | 1.3750                                  | .806           | .125           | 1.438                | 1.375               |
| 23         | 488-XXX       | 1.5000                                  | .838           | .156           | 1.563                | 1.500               |
| 25         | 489-XXX       | 1.6250                                  | .838           | .156           | 1.688                | 1.625               |

**38999, Series III Hermetic, Stainless Steel - PCB Contacts**  
TVSHIY Weld Mounting Receptacle

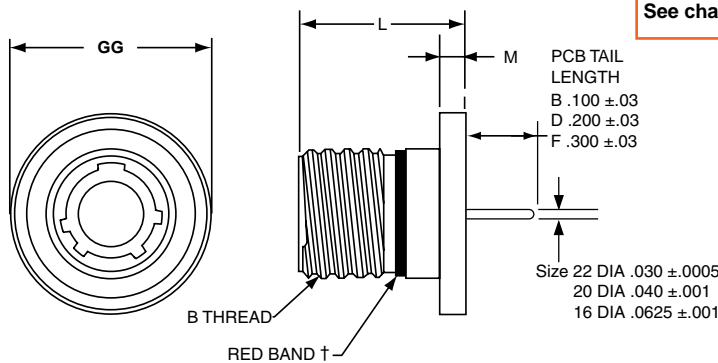

**PART #**  
See chart below

| 1.          | 2.               | 3.           | 4.                                 | 5.           | 6.          |
|-------------|------------------|--------------|------------------------------------|--------------|-------------|
| Base Number | Coded Shell Size | Insert Arrg. | Contact Type/Alt. Keying Positions | Shell Finish | Tail Length |
| 10-626      | 491              | -35          | P                                  | 1            | B           |

**HOW TO ORDER**

- Base Number:**  
10-626 Base Number for MIL-DTL-38999 Series III Hermetic with PCB Tail
- Select a Coded Shell Size:**  
See chart below 491-499, designates size 9-25 shell size
- Select an Insert Arrangement:**  
Refer to insert availability chart on page 239 and pin-out illustrations on pages 241-255. In the chart the first number represents the Shell size and the second number is the insert Arrg.  
-35 Designates Insert Arrangement Number
- Contact Type/Alternate Keying Positions:**  
Refer to page 240 for alternate rotation letters to use.  
P Designates Pin Contacts in Normal Position  
S Designates Socket Contacts in Normal Position
- Select a Shell Finish:**  
1 Hermetic seal, passivated Stainless Steel, 200°C  
2 \*Hermetic seal, Stainless Steel w/Nickel Plate
- Select a Tail Length:**  
B .100±.03  
D .200±.03  
F .300±.03

† Red band indicates fully mated

| Shell Size | Part Number   | B Thread Class 2A 0.1P-0.3L-TS (Plated) | L +.011 - .000 | M +.006 - .005 | GG Dia. +.011 - .010 |
|------------|---------------|---|----------------|----------------|----------------------|
| 9          | 10-626491-XXX | .6250                                   | .806           | .125           | .973                 |
| 11         | 492-XXX       | .7500                                   | .806           | .125           | 1.095                |
| 13         | 493-XXX       | .8750                                   | .806           | .125           | 1.221                |
| 15         | 494-XXX       | 1.0000                                  | .806           | .125           | 1.347                |
| 17         | 495-XXX       | 1.1875                                  | .806           | .125           | 1.434                |
| 19         | 496-XXX       | 1.2500                                  | .806           | .125           | 1.579                |
| 21         | 497-XXX       | 1.3750                                  | .806           | .125           | 1.721                |
| 23         | 498-XXX       | 1.5000                                  | .838           | .156           | 1.886                |
| 25         | 499-XXX       | 1.6250                                  | .838           | .156           | 1.973                |

\* Not available for weld mount

All dimensions for reference only.

### Box Mounting Receptacle

Series III TV

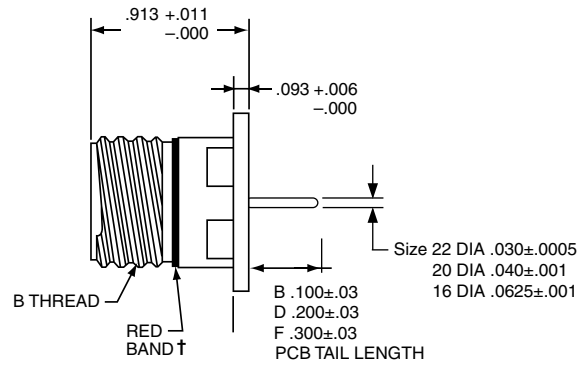
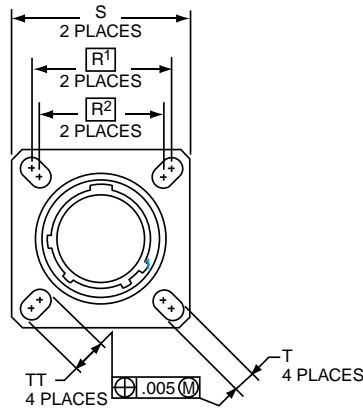

| PART #          | 1. Base Number | 2. Coded Shell Size | 3. Insert Arrg. | 4. Contact Type/Alt. Keying Positions | 5. Shell Finish | 6. Tail Length |
|-----------------|----------------|---------------------|-----------------|---------------------------------------|-----------------|----------------|
| See chart below | 10-626         | 50                  | -35             | P                                     | 1               | B              |

### HOW TO ORDER

#### 1. Base Number:

|        |   |
|--------|---|
| 10-626 | Base Number for MIL-DTL-38999 Series III Hermetic with PCB Tail |
|--------|---|

#### 2. Select a Coded Shell Size:

See chart below 501-509, designates size 9-25 shell size. Example: 501= Size 9 Shell

#### 3. Select an Insert Arrangement:

Refer to insert availability chart on page 239 and pin-out illustrations on pages 241-255. In the chart the first number represents the Shell size and the second number is the insert Arrangement.

|     |                                      |
|-----|--------------------------------------|
| -35 | Designates Insert Arrangement Number |
|-----|--------------------------------------|

#### 4. Contact Type/Alternate Keying Positions:

Refer to page 240 for alternate rotation letters to use.

|   |   |
|---|---|
| P | Designates Pin Contacts in Normal Position    |
| S | Designates Socket Contacts in Normal Position |

#### 5. Select a Shell Finish:

|   |  |
|---|--|
| 1 | Hermetic seal, passivated Stainless Steel, 200°C |
| 2 | Hermetic seal, Stainless Steel w/Nickel Plate    |

#### 6. Select a Tail Length:

|   |          |
|---|----------|
| B | .100±.03 |
| D | .200±.03 |
| F | .300±.03 |

| Shell Size | Part Number   | B Thread 0.1P-0.3L-TS (Plated) | R1    | R2    | S ±.010 | T ±.008 | TT ±.008 |
|------------|---------------|--------------------------------|-------|-------|---------|---------|----------|
| 9          | 10-626501-XXX | .6250                          | .719  | .594  | .938    | .128    | .216     |
| 11         | 502-XXX       | .7500                          | .812  | .719  | 1.031   | .128    | .194     |
| 13         | 503-XXX       | .8750                          | .906  | .812  | 1.125   | .128    | .194     |
| 15         | 504-XXX       | 1.0000                         | .969  | .906  | 1.219   | .128    | .173     |
| 17         | 505-XXX       | 1.1875                         | 1.062 | .969  | 1.312   | .128    | .194     |
| 19         | 506-XXX       | 1.2500                         | 1.156 | 1.062 | 1.438   | .128    | .194     |
| 21         | 507-XXX       | 1.3750                         | 1.250 | 1.156 | 1.562   | .128    | .194     |
| 23         | 508-XXX       | 1.5000                         | 1.375 | 1.250 | 1.688   | .154    | .242     |
| 25         | 509-XXX       | 1.6250                         | 1.500 | 1.375 | 1.812   | .154    | .242     |

† Red band indicates fully mated

NOTE: Consult Amphenol Aerospace for availability of non-glass-sealed versions with printed circuit tail contacts.

All dimensions for reference only

□ Designates true position dimensioning

- III 38999
- II
- I
- SJT
- Matrix 2 26482
- Matrix 83723 III
- Pyle 5015
- Crimp Rear Release Matrix 26500 Pyle

Printed Circuit Board

EMI Filter Transient

Fiber Optics

High Speed Contacts

Options Others

### Series II JT

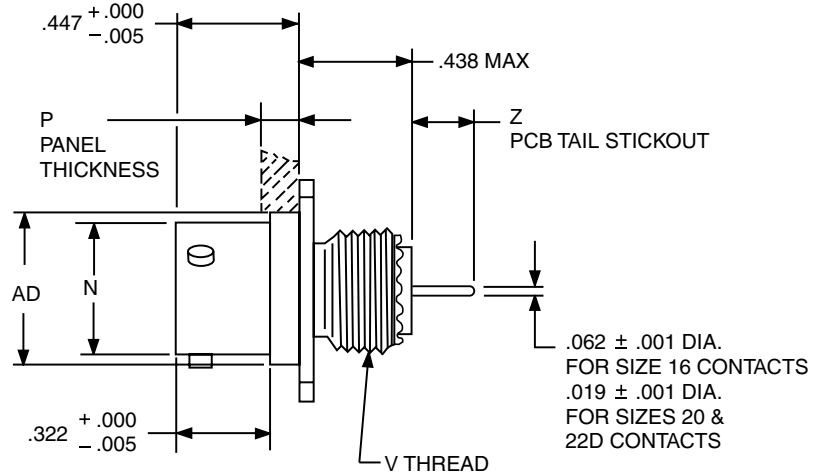
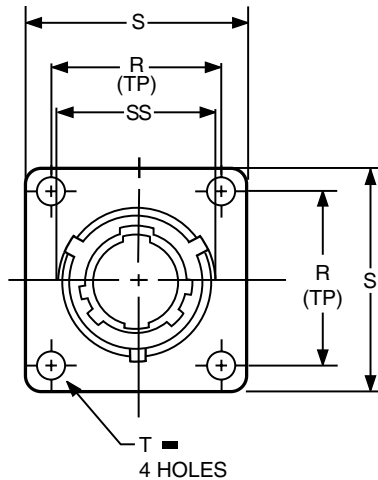

| PART #          | 1. Shell Finish | 2. Base Number | 3. Coded Shell Size | 4. Insert Arrangement | 5. Contact Type/Alt. Keying Positions |
|-----------------|-----------------|----------------|---------------------|-----------------------|---------------------------------------|
| See chart below | 88/91           | 569            | 731                 | -35                   | P                                     |

### HOW TO ORDER

#### 1. Select a Shell Finish:

|    |  |
|----|--|
| 88 | Designates olive drab cadmium plated connector shell |
| 91 | Designates electroless nickel plated connector shell |

#### 2. Base Number:

|     |             |
|-----|-------------|
| 569 | Base Number |
|-----|-------------|

#### 3. Select a Coded Shell Size:

See chart below 731-739, designates size 9-25 shell size.  
Example: 731= Size 9 Shell

#### 4. Select an Insert Arrangement:

Refer to insert availability chart on page 239 and pin-out illustrations on pages 241-255. In the chart the first number represents the Shell size and the second number is the insert Arrangement.

|     |                                      |
|-----|--------------------------------------|
| -35 | Designates Insert Arrangement Number |
|-----|--------------------------------------|

#### 5. Contact Type/Alternate Keying Positions:

Refer to page 240 for alternate rotation letters to use.

|   |   |
|---|---|
| P | Designates Pin Contacts in Normal Position    |
| S | Designates Socket Contacts in Normal Position |

■ ⊕ .005 DIA (M)

| Shell Size | Part Number      | N<br>+.001<br>-.005 | P Max.<br>Panel<br>Thickness | R<br>(TP) | S<br>±.016 | T<br>Dia.<br>±.005 | VThread<br>Class 2A<br>(Plated) | AD<br>Dia.<br>±.005 | SS Dia.<br>+.000<br>-.016 | Z                           |                      |
|------------|------------------|---------------------|------------------------------|-----------|------------|--------------------|---------------------------------|---------------------|---------------------------|-----------------------------|----------------------|
|            |                  |                     |                              |           |            |                    |                                 |                     |                           | Size<br>16 & 20<br>Contacts | Size 22D<br>Contacts |
| 8          | 88/91-569731-XXX | .473                | .142                         | .594      | .812       | .120               | .4375-28 UNEF                   | .516                | .563                      | .257 - .200                 | .268 - .178          |
| 10         | 732-XXX          | .590                | .142                         | .719      | .938       | .120               | .5625-24 UNEF                   | .633                | .680                      | .257 - .200                 | .268 - .178          |
| 12         | 733-XXX          | .750                | .142                         | .812      | 1.031      | .120               | .6875-24 UNEF                   | .802                | .859                      | .257 - .200                 | .268 - .178          |
| 14         | 734-XXX          | .875                | .142                         | .906      | 1.125      | .120               | .8125-20 UNEF                   | .927                | .984                      | .257 - .200                 | .268 - .178          |
| 16         | 735-XXX          | 1.000               | .142                         | .969      | 1.219      | .120               | .9375-20 UNEF                   | 1.052               | 1.108                     | .257 - .200                 | .268 - .178          |
| 18         | 736-XXX          | 1.125               | .142                         | 1.062     | 1.312      | .120               | 1.0625-18 UNEF                  | 1.177               | 1.233                     | .257 - .200                 | .268 - .178          |
| 20         | 737-XXX          | 1.250               | .142                         | 1.156     | 1.438      | .120               | 1.1875-18 UNEF                  | 1.302               | 1.358                     | .257 - .200                 | .268 - .178          |
| 22         | 738-XXX          | 1.375               | .142                         | 1.250     | 1.562      | .120               | 1.3125-18 UNEF                  | 1.427               | 1.483                     | .257 - .200                 | .268 - .178          |
| 24         | 739-XXX          | 1.500               | .142                         | 1.375     | 1.688      | .147               | 1.4375-18 UNEF                  | 1.552               | 1.610                     | .257 - .200                 | .268 - .178          |

All dimensions for reference only.

Z dimension is determined by contact type in the insert arrangement.

Most common options are shown; other options are available.

# 38999, Series II with PCB Contacts JTP02R Box Mounting Receptacle

(Back Panel Mounting)

Series II JT

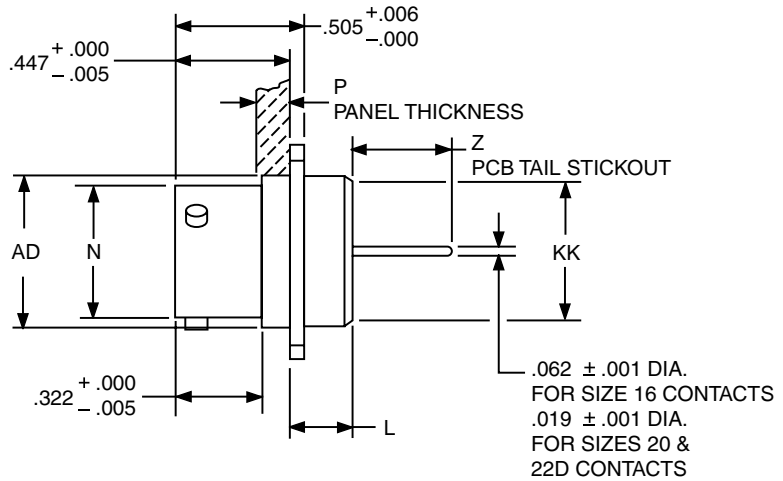
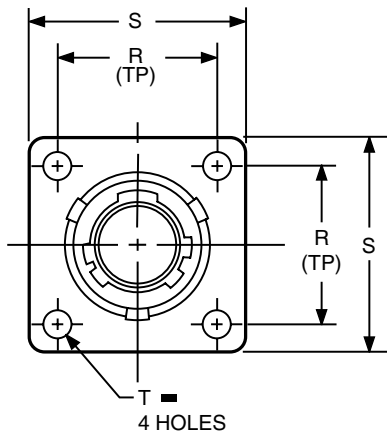

| PART #          | Shell Finish | Base Number | Coded Shell Size | Insert Arrangement | Contact Type/Alt. Keying Positions |
|-----------------|--------------|-------------|------------------|--------------------|------------------------------------|
| See chart below | 88/91        | 569         | 741              | -35                | P                                  |

## HOW TO ORDER

### 1. Select a Shell Finish:

|    |  |
|----|--|
| 88 | Designates olive drab cadmium plated connector shell |
| 91 | Designates electroless nickel plated connector shell |

### 2. Base Number:

|     |             |
|-----|-------------|
| 569 | Base Number |
|-----|-------------|

### 3. Select a Coded Shell Size:

See chart below 741-749, designates size 9-25 shell size.  
Example: 741= Size 9 Shell

### 4. Select an Insert Arrangement:

Refer to insert availability chart on page 239 and pin-out illustrations on pages 241-255. In the chart the first number represents the Shell size and the second number is the insert Arrangement.

|     |                                      |
|-----|--------------------------------------|
| -35 | Designates Insert Arrangement Number |
|-----|--------------------------------------|

### 5. Contact Type/Alternate Keying Positions:

Refer to page 240 for alternate rotation letters to use.

|   |   |
|---|---|
| P | Designates Pin Contacts in Normal Position    |
| S | Designates Socket Contacts in Normal Position |

⊕ .005 DIA (M)

| Shell Size | Part Number      | L Max. | N +.001 - .005 | P Max. Panel Thickness | R (TP) | S ±.016 | T Dia. ±.005 | AD Dia. ±.005 | KK Dia. Max. | Z                     |                   |
|------------|------------------|--------|----------------|------------------------|--------|---------|--------------|---------------|--------------|-----------------------|-------------------|
|            |                  |        |                |                        |        |         |              |               |              | Size 16 & 20 Contacts | Size 22D Contacts |
| 8          | 88/91-569741-XXX | .225   | .473           | .147                   | .594   | .812    | .120         | .516          | .531         | .455 - .403           | .466 - .409       |
| 10         | 742-XXX          | .225   | .590           | .152                   | .719   | .938    | .120         | .633          | .656         | .455 - .403           | .466 - .409       |
| 12         | 743-XXX          | .225   | .750           | .152                   | .812   | 1.031   | .120         | .802          | .828         | .455 - .403           | .466 - .409       |
| 14         | 744-XXX          | .225   | .875           | .152                   | .906   | 1.125   | .120         | .927          | .953         | .455 - .403           | .466 - .409       |
| 16         | 745-XXX          | .225   | 1.000          | .152                   | .969   | 1.219   | .120         | 1.052         | 1.078        | .455 - .403           | .466 - .409       |
| 18         | 746-XXX          | .225   | 1.125          | .152                   | 1.062  | 1.312   | .120         | 1.177         | 1.203        | .455 - .403           | .466 - .409       |
| 20         | 747-XXX          | .225   | 1.250          | .179                   | 1.156  | 1.438   | .120         | 1.302         | 1.328        | .455 - .403           | .466 - .409       |
| 22         | 748-XXX          | .225   | 1.375          | .179                   | 1.250  | 1.562   | .120         | 1.427         | 1.453        | .455 - .403           | .466 - .409       |
| 24         | 749-XXX          | .225   | 1.500          | .169                   | 1.375  | 1.688   | .147         | 1.552         | 1.578        | .455 - .403           | .466 - .409       |

All dimensions for reference only.  
Z dimension is determined by contact type in the insert arrangement.  
Most common options are shown; other options are available.

III 38999  
II  
I  
SJT

26482 Matrix 2

83723 III Matrix Pyle

5015 Crimp Rear Release Matrix

26500 Pyle

Printed Circuit Board

EMI Filter Transient

Fiber Optics

High Speed Contacts

Options Others

### Series II JT

38999  
SJT I II III

26482  
Matrix 2

83723 III  
Matrix Pyle

5015  
Crimp Rear Release Matrix

26500 Pyle

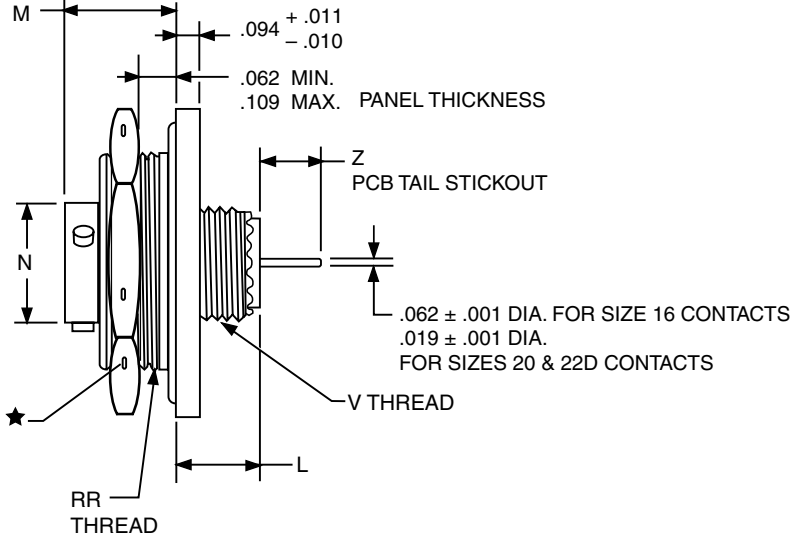
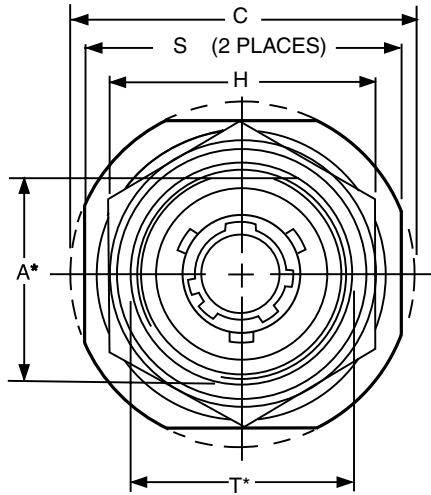

| PART #          | 1. Shell Finish | 2. Base Number | 3. Coded Shell Size | 4. Insert Arrangement | 5. Contact Type/Alt. Keying Positions |
|-----------------|-----------------|----------------|---------------------|-----------------------|---------------------------------------|
| See chart below | 88/91           | 569            | 751                 | -35                   | P                                     |

### HOW TO ORDER

#### 1. Select a Shell Finish:

|    |  |
|----|--|
| 88 | Designates olive drab cadmium plated connector shell |
| 91 | Designates electroless nickel plated connector shell |

#### 2. Base Number:

|     |             |
|-----|-------------|
| 569 | Base Number |
|-----|-------------|

#### 3. Select a Coded Shell Size:

See chart below **751-759**, designates size 8-25 shell size.  
Example: **751** = Size 8 Shell

#### 4. Select an Insert Arrangement:

Refer to insert availability chart on page 239 and pin-out illustrations on pages 241-255. In the chart the first number represents the Shell size and the second number is the insert Arrangement.

|     |                                      |
|-----|--------------------------------------|
| -35 | Designates Insert Arrangement Number |
|-----|--------------------------------------|

#### 5. Contact Type/Alternate Keying Positions:

Refer to page 240 for alternate rotation letters to use.

|   |   |
|---|---|
| P | Designates Pin Contacts in Normal Position    |
| S | Designates Socket Contacts in Normal Position |

| Shell Size | Part Number      | A*<br>+.000<br>-.010 | C<br>Max. | H Hex<br>+.017<br>-.016 | L<br>Max. | M<br>±.005 | N<br>+.001<br>-.005 | S<br>±.016 | T*<br>+.010<br>-.000 | V Thread<br>Class 2A<br>(Plated) | RR Thread<br>Class 2A<br>(Plated) | Z                           |                      |
|------------|------------------|----------------------|-----------|-------------------------|-----------|------------|---------------------|------------|----------------------|----------------------------------|-----------------------------------|-----------------------------|----------------------|
|            |                  |                      |           |                         |           |            |                     |            |                      |                                  |                                   | Size<br>16 & 20<br>Contacts | Size 22D<br>Contacts |
| 8          | 88/91-569751-XXX | .830                 | 1.390     | 1.062                   | .453      | .438       | .473                | 1.250      | .884                 | .4375-28 UNEF                    | .8750-20 UNEF                     | .272 - .200                 | .283 - .178          |
| 10         | 752-XXX          | .955                 | 1.515     | 1.188                   | .453      | .438       | .590                | 1.375      | 1.007                | .5625-24 UNEF                    | 1.0000-20 UNEF                    | .272 - .200                 | .283 - .178          |
| 12         | 753-XXX          | 1.084                | 1.640     | 1.312                   | .453      | .438       | .750                | 1.500      | 1.134                | .6875-24 UNEF                    | 1.1250-18 UNEF                    | .272 - .200                 | .283 - .178          |
| 14         | 754-XXX          | 1.208                | 1.765     | 1.438                   | .453      | .438       | .875                | 1.625      | 1.259                | .8125-20 UNEF                    | 1.2500-18 UNEF                    | .272 - .200                 | .283 - .178          |
| 16         | 755-XXX          | 1.333                | 1.953     | 1.562                   | .453      | .438       | 1.000               | 1.781      | 1.384                | .9375-20 UNEF                    | 1.3750-18 UNEF                    | .272 - .200                 | .283 - .178          |
| 18         | 756-XXX          | 1.459                | 2.031     | 1.688                   | .453      | .438       | 1.125               | 1.890      | 1.507                | 1.0625-18 UNEF                   | 1.5000-18 UNEF                    | .272 - .200                 | .283 - .178          |
| 20         | 757-XXX          | 1.576                | 2.156     | 1.812                   | .422      | .464       | 1.250               | 2.016      | 1.634                | 1.1875-18 UNEF                   | 1.6250-18 UNEF                    | .272 - .200                 | .283 - .178          |
| 22         | 758-XXX          | 1.701                | 2.280     | 2.000                   | .422      | .464       | 1.375               | 2.140      | 1.759                | 1.3125-18 UNEF                   | 1.7500-18 UNS                     | .272 - .200                 | .283 - .178          |
| 24         | 759-XXX          | 1.826                | 2.405     | 2.125                   | .422      | .464       | 1.500               | 2.265      | 1.884                | 1.4375-18 UNEF                   | 1.8750-16 UN                      | .272 - .200                 | .283 - .178          |

All dimensions for reference only.  
Z dimension is determined by contact type in the insert arrangement.  
Most common options are shown; other options are available.

★ .059 dia. min. 3 lockwire holes.  
Formed lockwire hole design (6 holes) is optional.  
\* "D" shaped mounting hole dimensions



# 38999, Series II Hermetic – PCB Contacts JT00 Wall Mounting Receptacle



## Series II JT

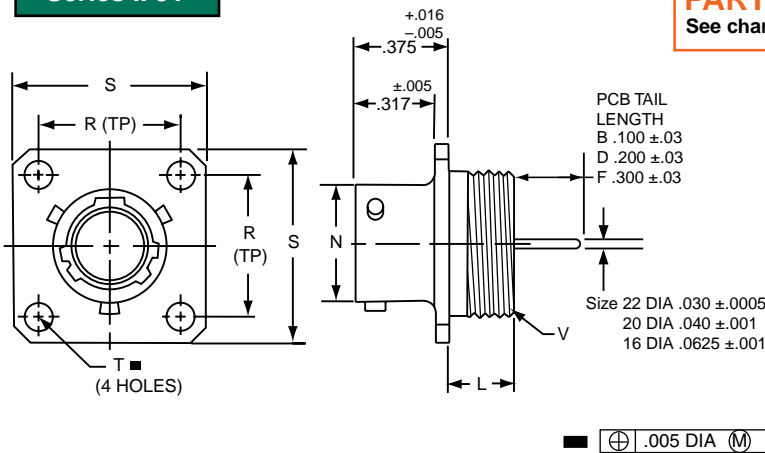

| Shell Size | Part Number   | L Max. | N<br>+.001<br>-.005 | R (TP) | S<br>±.016 | T<br>±.005 | V Thread Class 2A |
|------------|---------------|--------|---------------------|--------|------------|------------|-------------------|
| 8          | 10-626431-XXX | .234   | .473                | .594   | .812       | .120       | .5625-24UNEF      |
| 10         | 432-XXX       | .234   | .590                | .719   | .938       | .120       | .6875-24UNEF      |
| 12         | 433-XXX       | .234   | .750                | .812   | 1.031      | .120       | .8125-20UNEF      |
| 14         | 434-XXX       | .234   | .875                | .906   | 1.125      | .120       | .9375-20UNEF      |
| 16         | 435-XXX       | .234   | 1.000               | .969   | 1.219      | .120       | 1.0625-18UNEF     |
| 18         | 436-XXX       | .234   | 1.125               | 1.062  | 1.312      | .120       | 1.1875-18UNEF     |
| 20         | 437-XXX       | .234   | 1.250               | 1.156  | 1.438      | .120       | 1.3125-18UNEF     |
| 22         | 438-XXX       | .234   | 1.375               | 1.250  | 1.562      | .120       | 1.4375-18UNEF     |
| 24         | 439-XXX       | .313   | 1.500               | 1.375  | 1.688      | .147       | 1.5625-18UNEF     |

### PART # See chart below

| 1. Base Number | 2. Coded Shell Size | 3. Insert Arrg. | 4. Contact Type/Alt. Keying Positions | 5. Shell Finish | 6. Tail Length |
|----------------|---------------------|-----------------|---------------------------------------|-----------------|----------------|
| 10-626         | 431                 | -35             | P                                     | 1               | B              |

### HOW TO ORDER

#### 1. Base Number:

**10-626** Base Number for MIL-DTL-38999 Series III Hermetic with PCB Tail

#### 2. Select a Coded Shell Size:

See chart below **431-439**, designates size 8-24 shell size

#### 3. Select an Insert Arrangement:

Refer to insert availability chart on page 239 and pin-out illustrations on pages 241-255. In the chart the first number represents the Shell size and the second number is the insert Arrangement.

**-35** Designates Insert Arrangement Number

#### 4. Contact Type/Alternate Keying Positions:

Refer to page 240 for alternate rotation letters to use.

**P** Designates Pin Contacts in Normal Position

**S** Designates Socket Contacts in Normal Position

#### 5. Select a Shell Finish:

**1** Hermetic seal, passivated Stainless Steel, 200°C

**2** Hermetic seal, Stainless Steel w/Nickel Plate

#### 6. Select a Tail Length:

**B** .100±.03

**D** .200±.03

**F** .300±.03

# 38999, Series II Hermetic – PCB Contacts JT02 Box Mounting Receptacle

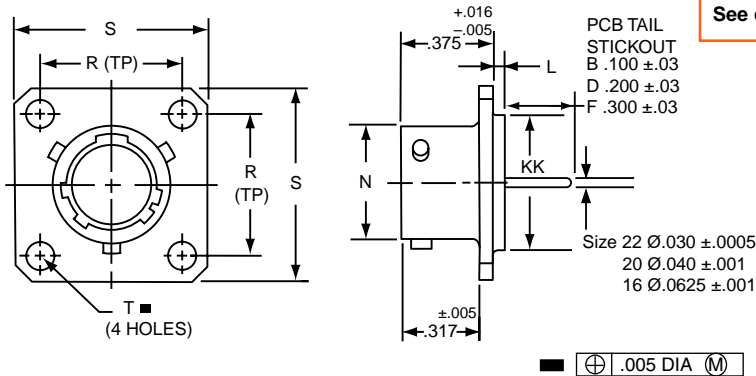

### PART # See chart below

| 1. Base Number | 2. Coded Shell Size | 3. Insert Arrg. | 4. Arrg Rotation | 5. Shell Finish | 6. Tail Length |
|----------------|---------------------|-----------------|------------------|-----------------|----------------|
| 10-626         | 46                  | -35             | P                | 1               | B              |

Follow HOW TO ORDER instructions above.

| Shell Size | Part Number   | L<br>+.006<br>-.015 | N<br>+.001<br>-.005 | R (TP) | S<br>±.016 | T<br>±.005 | KK<br>+.001<br>-.005 |
|------------|---------------|---------------------|---------------------|--------|------------|------------|----------------------|
| 8          | 10-626461-XXX | .051                | .473                | .594   | .812       | .120       | .562                 |
| 10         | 462-XXX       | .051                | .590                | .719   | .938       | .120       | .672                 |
| 12         | 463-XXX       | .051                | .750                | .812   | 1.031      | .120       | .781                 |
| 14         | 464-XXX       | .051                | .875                | .906   | 1.125      | .120       | .906                 |
| 16         | 465-XXX       | .051                | 1.000               | .969   | 1.219      | .120       | 1.031                |
| 18         | 466-XXX       | .051                | 1.125               | 1.062  | 1.312      | .120       | 1.156                |
| 20         | 467-XXX       | .051                | 1.250               | 1.156  | 1.438      | .120       | 1.250                |
| 22         | 468-XXX       | .080                | 1.375               | 1.250  | 1.562      | .120       | 1.375                |
| 24         | 469-XXX       | .080                | 1.500               | 1.375  | 1.688      | .147       | 1.500                |

All dimensions for reference only.

38999  
SJT  
Matrix 2  
83723 III  
Matrix Pyle  
5015  
Crimp Rear  
Release Matrix  
26500 Pyle

Printed  
Circuit Board  
EMI Filter  
Transient  
Fiber Optics  
High Speed  
Contacts  
Options  
Others

**Series II JT**

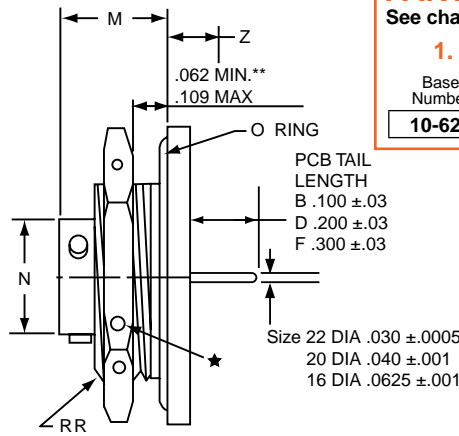
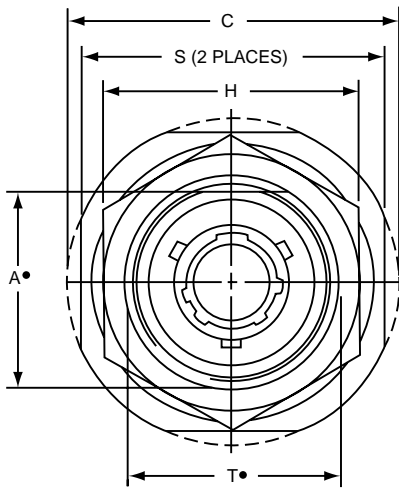

**PART #**

See chart below

| 1.          | 2.               | 3.           | 4.                                 | 5.           | 6.          |
|-------------|------------------|--------------|------------------------------------|--------------|-------------|
| Base Number | Coded Shell Size | Insert Arrg. | Contact Type/Alt. Keying Positions | Shell Finish | Tail Length |
| 10-626      | 441              | -35          | P                                  | 1            | B           |

Follow HOW TO ORDER instructions below.

| Shell Size | Part Number   | A*<br>+.000<br>-.010 | C Max. | H<br>+.017<br>-.016 | M ±.005 | N +.001<br>-.005 | S<br>±.016 | T*<br>+.010<br>-.000 | Z Max. | RR Thread Class 2A |
|------------|---------------|----------------------|--------|---------------------|---------|------------------|------------|----------------------|--------|--------------------|
| 8          | 10-626441-XXX | .830                 | 1.390  | 1.062               | .438    | .473             | 1.250      | .884                 | .244   | .8750-20UNEF       |
| 10         | 442-XXX       | .955                 | 1.515  | 1.188               | .438    | .590             | 1.375      | 1.007                | .244   | 1.0000-20UNEF      |
| 12         | 443-XXX       | 1.084                | 1.640  | 1.312               | .438    | .750             | 1.500      | 1.134                | .244   | 1.1250-18UNEF      |
| 14         | 444-XXX       | 1.208                | 1.765  | 1.438               | .438    | .875             | 1.625      | 1.259                | .244   | 1.2500-18UNEF      |
| 16         | 445-XXX       | 1.333                | 1.953  | 1.562               | .438    | 1.000            | 1.781      | 1.384                | .244   | 1.3750-18UNEF      |
| 18         | 446-XXX       | 1.459                | 2.031  | 1.688               | .438    | 1.125            | 1.890      | 1.507                | .244   | 1.5000-18UNEF      |
| 20         | 447-XXX       | 1.576                | 2.156  | 1.812               | .464    | 1.250            | 2.016      | 1.634                | .218   | 1.6250-18UNEF      |
| 22         | 448-XXX       | 1.701                | 2.280  | 2.000               | .464    | 1.375            | 2.140      | 1.759                | .218   | 1.7500-18UNS       |
| 24         | 449-XXX       | 1.826                | 2.405  | 2.125               | .464    | 1.500            | 2.265      | 1.884                | .218   | 1.8750-16UN        |

★ .059 Dia. Min. 3 lockwire holes. Formed lockwire hole design (6 holes) is optional.

• "D" shaped mounting hole dimensions.

\*\* Panel Thickness

All dimensions for reference only.

**38999, Series II Hermetic, PCB Contacts**  
**JTI Solder Mounting Receptacle**

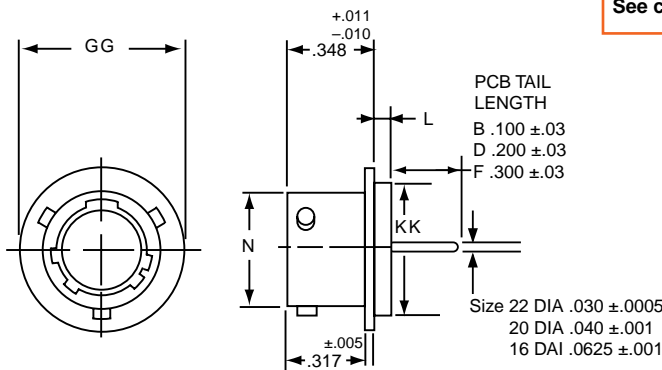

**PART #**

See chart below

| 1.          | 2.               | 3.           | 4.                                 | 5.           | 6.          |
|-------------|------------------|--------------|------------------------------------|--------------|-------------|
| Base Number | Coded Shell Size | Insert Arrg. | Contact Type/Alt. Keying Positions | Shell Finish | Tail Length |
| 10-626      | 451              | -35          | P                                  | 1            | B           |

**HOW TO ORDER**

**1. Base Number:**

10-626 Base Number for MIL-DTL-38999 Series III Hermetic with PCB Tail

**2. Select a Coded Shell Size:**

See chart below 451-459, designates size 8-24 shell size

**3. Select an Insert Arrangement:**

Refer to insert availability chart on page 239 and pin-out illustrations on pages 241-255. In the chart the first number represents the Shell size and the second number is the insert Arrangement.

-35 Designates Insert Arrangement Number

**4. Contact Type/Alternate Keying Positions:**

Refer to page 240 for alternate rotation letters to use.

P Designates Pin Contacts in Normal Position  
S Designates Socket Contacts in Normal Position

**5. Select a Shell Finish:**

1 Hermetic seal, passivated Stainless Steel, 200°C  
2 Hermetic seal, Stainless Steel w/Nickel Plate

**6. Select a Tail Length:**

B .100±.03  
D .200±.03  
F .300±.03

| Shell Size | Part Number   | L<br>+.011<br>-.010 | N<br>+.001<br>-.005 | GG<br>+.011<br>-.010 | KK<br>+.001<br>-.005 |
|------------|---------------|---------------------|---------------------|----------------------|----------------------|
| 8          | 10-626451-XXX | .078                | .473                | .687                 | .562                 |
| 10         | 452-XXX       | .078                | .590                | .797                 | .672                 |
| 12         | 453-XXX       | .078                | .750                | .906                 | .781                 |
| 14         | 454-XXX       | .078                | .875                | 1.031                | .906                 |
| 16         | 455-XXX       | .078                | 1.000               | 1.156                | 1.031                |
| 18         | 456-XXX       | .078                | 1.125               | 1.281                | 1.156                |
| 20         | 457-XXX       | .078                | 1.250               | 1.375                | 1.250                |
| 22         | 458-XXX       | .107                | 1.375               | 1.500                | 1.375                |
| 24         | 459-XXX       | .107                | 1.500               | 1.625                | 1.500                |

All dimensions for reference only. Weld mounting hermetic receptacle also available. Consult Amphenol, Sidney, NY for availability and dimensions.

(Back Panel Mounting)

**Series I LJT**

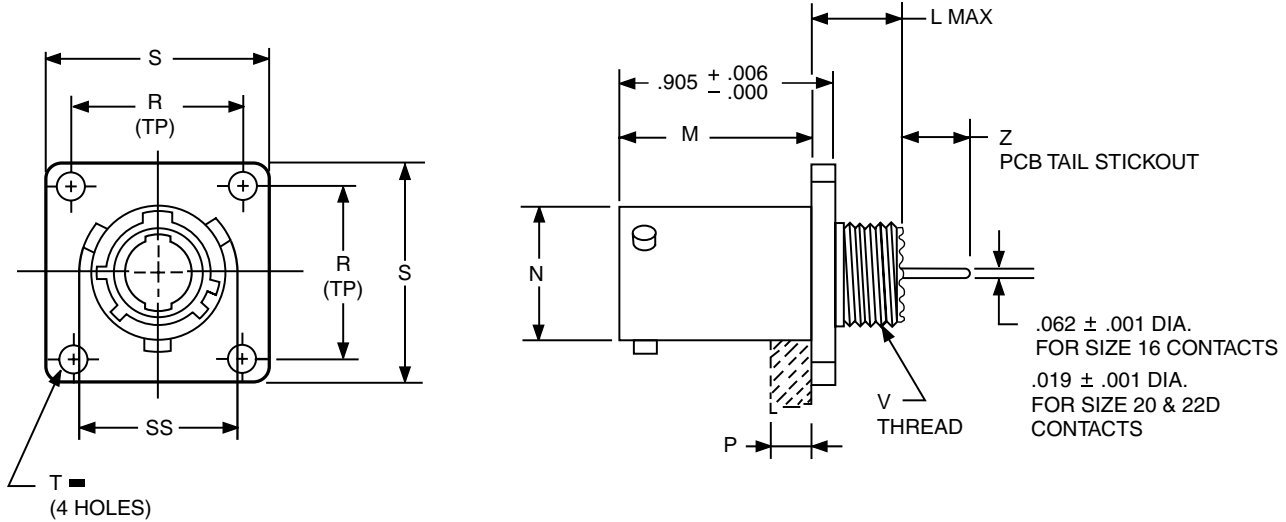

|                 | 1.           | 2.          | 3.               | 4.                 | 5.                                 |
|-----------------|--------------|-------------|------------------|--------------------|------------------------------------|
| PART #          | Shell Finish | Base Number | Coded Shell Size | Insert Arrangement | Contact Type/Alt. Keying Positions |
| See chart below | 88/91        | 569         | 701              | -35                | P                                  |

## HOW TO ORDER

### 1. Select a Shell Finish:

|    |  |
|----|--|
| 88 | Designates olive drab cadmium plated connector shell |
| 91 | Designates electroless nickel plated connector shell |

### 2. Base Number:

|     |             |
|-----|-------------|
| 569 | Base Number |
|-----|-------------|

### 3. Select a Coded Shell Size:

See chart below **701-709**, designates size 9-25 shell size.  
Example: **701**= Size 9 Shell

### 4. Select an Insert Arrangement:

Refer to insert availability chart on page 239 and pin-out illustrations on pages 241-255. In the chart the first number represents the Shell size and the second number is the insert Arrangement.

|     |                                      |
|-----|--------------------------------------|
| -35 | Designates Insert Arrangement Number |
|-----|--------------------------------------|

### 5. Contact Type/Alternate Keying Positions:

Refer to page 240 for alternate rotation letters to use.

|   |   |
|---|---|
| P | Designates Pin Contacts in Normal Position    |
| S | Designates Socket Contacts in Normal Position |

■ ⊕ .005 DIA ⊙

| Shell Size | Part Number      | L Max. | M +.000 / -.005 | N Dia. | P Max. Panel Thickness | R (TP) | S +.011 / -.010 | T Dia. ±.005 | V Thread Class 2A (Plated) | SS Dia. +.000 / -.016 | Z                     |                   |
|------------|------------------|--------|-----------------|--------|------------------------|--------|-----------------|--------------|----------------------------|-----------------------|-----------------------|-------------------|
|            |                  |        |                 |        |                        |        |                 |              |                            |                       | Size 16 & 20 Contacts | Size 22D Contacts |
| 9          | 88/91-569701-XXX | .453   | .820            | .572   | .234                   | .719   | .938            | .128         | .4375-28 UNEF              | .662                  | .281 – .235           | .249 – .188       |
| 11         | 702-XXX          | .453   | .820            | .700   | .234                   | .812   | 1.031           | .128         | .5625-24 UNEF              | .810                  | .281 – .235           | .249 – .188       |
| 13         | 703-XXX          | .453   | .820            | .850   | .234                   | .906   | 1.125           | .128         | .6875-24 UNEF              | .960                  | .281 – .235           | .249 – .188       |
| 15         | 704-XXX          | .453   | .820            | .975   | .234                   | .969   | 1.219           | .128         | .8125-20 UNEF              | 1.085                 | .281 – .235           | .249 – .188       |
| 17         | 705-XXX          | .453   | .820            | 1.100  | .234                   | 1.062  | 1.312           | .128         | .9375-20 UNEF              | 1.210                 | .281 – .235           | .249 – .188       |
| 19         | 706-XXX          | .453   | .820            | 1.207  | .234                   | 1.156  | 1.438           | .128         | 1.0625-18 UNEF             | 1.317                 | .281 – .235           | .249 – .188       |
| 21         | 707-XXX          | .484   | .790            | 1.332  | .204                   | 1.250  | 1.562           | .128         | 1.1875-18 UNEF             | 1.442                 | .281 – .235           | .249 – .188       |
| 23         | 708-XXX          | .484   | .790            | 1.457  | .204                   | 1.375  | 1.688           | .147         | 1.3125-18 UNEF             | 1.567                 | .281 – .235           | .249 – .188       |
| 25         | 709-XXX          | .484   | .790            | 1.582  | .193                   | 1.500  | 1.812           | .147         | 1.4375-18 UNEF             | 1.692                 | .281 – .235           | .249 – .188       |

All dimensions for reference only.  
Z dimension is determined by contact type in the insert arrangement.  
Most common options are shown; other options are available.

- III 38999
- II 26482 Matrix 2
- I 83723 III Matrix Pyle
- SJT 5015 Crimp Rear Release Matrix
- 26500 Pyle

Printed Circuit Board

EMI Filter Transient

Fiber Optics

High Speed Contacts

Options Others

**(Back Panel Mounting) (With Clinch Nuts)**

**Series I LJT**

38999  
SJT I II III

26482  
Matrix 2

83723 III  
Matrix Pyle

5015  
Crimp Rear  
Release Matrix

26500 Pyle

Printed  
Circuit Board

EMI Filter  
Transient

Fiber Optics

High Speed  
Contacts

Options  
Others

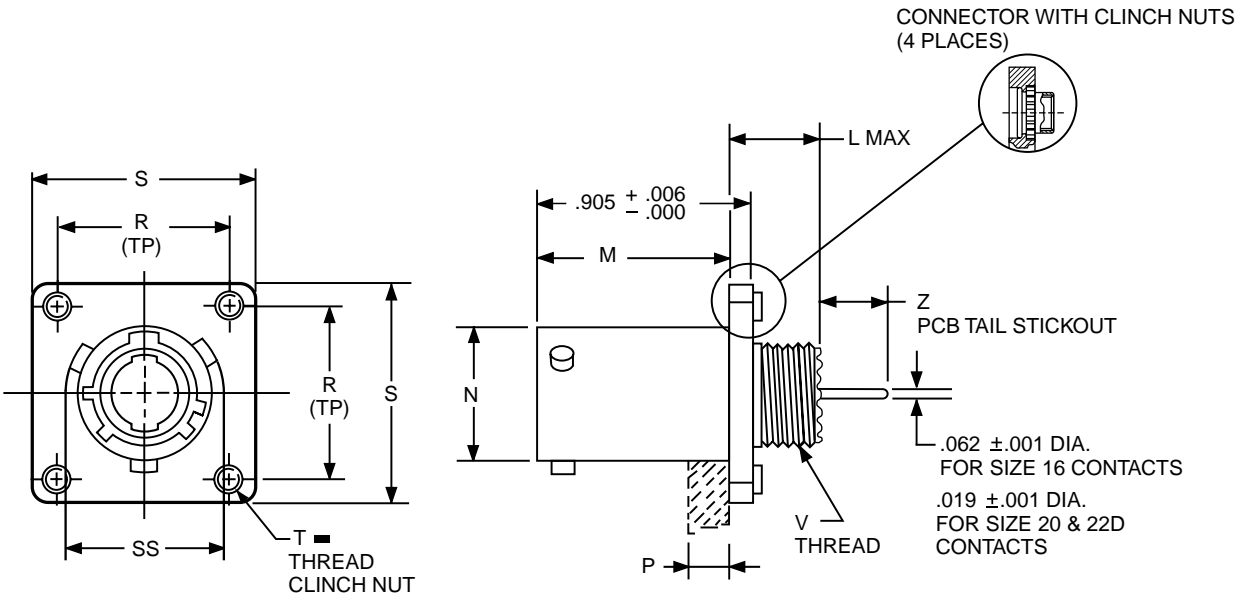

| PART #          | 1. Shell Finish | 2. Base Number | 3. Coded Shell Size | 4. Insert Arrangement | 5. Contact Type/Alt. Keying Positions |
|-----------------|-----------------|----------------|---------------------|-----------------------|---------------------------------------|
| See chart below | 88/91           | 628            | 70                  | -35                   | P                                     |

**HOW TO ORDER**

**1. Select a Shell Finish:**

|           |  |
|-----------|--|
| <b>88</b> | Designates olive drab cadmium plated connector shell |
| <b>91</b> | Designates electroless nickel plated connector shell |

**2. Base Number:**

|            |             |
|------------|-------------|
| <b>628</b> | Base Number |
|------------|-------------|

**3. Select a Coded Shell Size:**

See chart below **701-709**, designates size 9-25 shell size.  
Example: **701**= Size 9 Shell

**4. Select an Insert Arrangement:**

Refer to insert availability chart on page 239 and pin-out illustrations on pages 241-255. First number represents the Shell size and the second number is the insert Arrangement.

|            |                                      |
|------------|--------------------------------------|
| <b>-35</b> | Designates Insert Arrangement Number |
|------------|--------------------------------------|

**5. Contact Type/Alternate Keying Positions:**

Refer to page 240 for alternate rotation letters to use.

|          |   |
|----------|---|
| <b>P</b> | Designates Pin Contacts in Normal Position    |
| <b>S</b> | Designates Socket Contacts in Normal Position |

⊕ .005 DIA ⊙

| Shell Size | Part Number with Clinch Nuts* | L Max. | M +.000 - .005 | N Dia. | P Max. Panel Thickness | R (TP) | S +.011 - .010 | T Thread       | V Thread Class 2A (Plated) | SS Dia. +.000 - .016 | Z                     |                   |
|------------|-------------------------------|--------|----------------|--------|------------------------|--------|----------------|----------------|----------------------------|----------------------|-----------------------|-------------------|
|            |                               |        |                |        |                        |        |                |                |                            |                      | Size 16 & 20 Contacts | Size 22D Contacts |
| 9          | 88/91-628 <b>701</b> -XXX     | .453   | .820           | .572   | .234                   | .719   | .938           | .112-40UNJC-3B | .4375-28 UNEF              | .662                 | .281 - .235           | .249 - .188       |
| 11         | <b>702</b> -XXX               | .453   | .820           | .700   | .234                   | .812   | 1.031          | .112-40UNJC-3B | .5625-24 UNEF              | .810                 | .281 - .235           | .249 - .188       |
| 13         | <b>703</b> -XXX               | .453   | .820           | .850   | .234                   | .906   | 1.125          | .112-40UNJC-3B | .6875-24 UNEF              | .960                 | .281 - .235           | .249 - .188       |
| 15         | <b>704</b> -XXX               | .453   | .820           | .975   | .234                   | .969   | 1.219          | .112-40UNJC-3B | .8125-20 UNEF              | 1.085                | .281 - .235           | .249 - .188       |
| 17         | <b>705</b> -XXX               | .453   | .820           | 1.100  | .234                   | 1.062  | 1.312          | .112-40UNJC-3B | .9375-20 UNEF              | 1.210                | .281 - .235           | .249 - .188       |
| 19         | <b>706</b> -XXX               | .453   | .820           | 1.207  | .234                   | 1.156  | 1.438          | .112-40UNJC-3B | 1.0625-18 UNEF             | 1.317                | .281 - .235           | .249 - .188       |
| 21         | <b>707</b> -XXX               | .484   | .790           | 1.332  | .204                   | 1.250  | 1.562          | .112-40UNJC-3B | 1.1875-18 UNEF             | 1.442                | .281 - .235           | .249 - .188       |
| 23         | <b>708</b> -XXX               | .484   | .790           | 1.457  | .204                   | 1.375  | 1.688          | .138-32UNJC-3B | 1.3125-18 UNEF             | 1.567                | .281 - .235           | .249 - .188       |
| 25         | <b>709</b> -XXX               | .484   | .790           | 1.582  | .193                   | 1.500  | 1.812          | .138-32UNJC-3B | 1.4375-18 UNEF             | 1.692                | .281 - .235           | .249 - .188       |

All dimensions for reference only.

\*Consult Amphenol for more information on ordering connectors with clinch nuts. There is also a 3mm clinch nut available (part number 88/91-628401/409)

Z dimension is determined by contact type in the insert arrangement.

Most common options are shown; other options are available.

# 38999, Series I with PCB Contacts

## LJTP02R Box Mounting Receptacle



(Back Panel Mounting)

Series I LJT

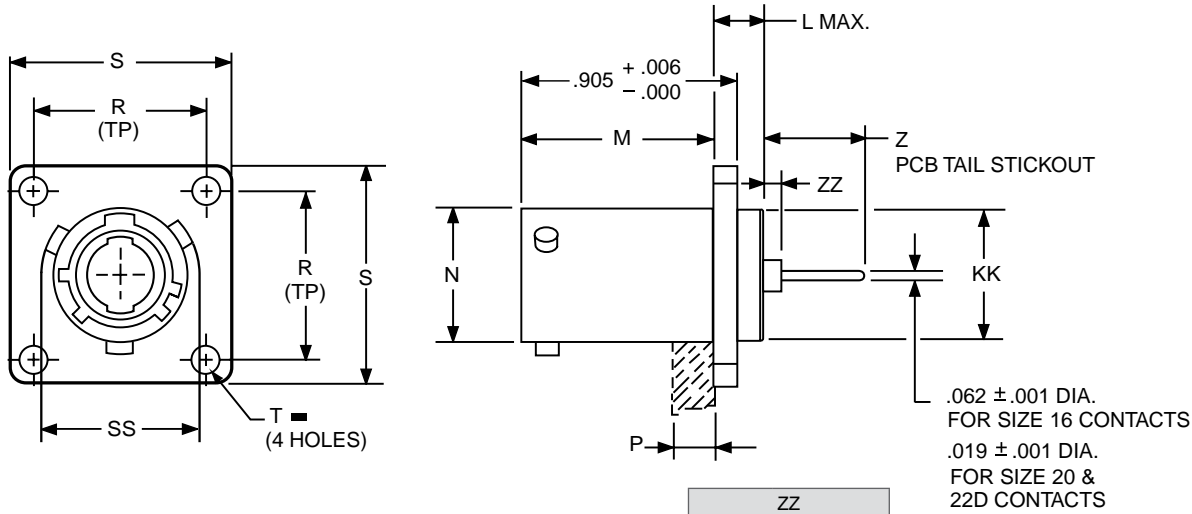

| ZZ      |            |
|---------|------------|
| Pins    |            |
| 12      | .176/.115  |
| 16      | .044/-.007 |
| 20      | .161/.100  |
| 22D     | .092/.031  |
| Sockets |            |
| 12      | .176/.112  |
| 16      | .092/.038  |
| 20      | .161/.097  |
| 22D     | .200/.129  |

| PART #          | Shell Finish | Base Number | Coded Shell Size | Insert Arrangement | Contact Type/Alt. Keying Positions |
|-----------------|--------------|-------------|------------------|--------------------|------------------------------------|
| See chart below | 88/91        | 569         | 71               | -35                | P                                  |

### HOW TO ORDER

#### 1. Select a Shell Finish:

|    |  |
|----|--|
| 88 | Designates olive drab cadmium plated connector shell |
| 91 | Designates electroless nickel plated connector shell |

#### 2. Base Number:

|     |             |
|-----|-------------|
| 569 | Base Number |
|-----|-------------|

#### 3. Select a Coded Shell Size:

See chart below 711-719, designates size 9-25 shell size.  
Example: 711= Size 9 Shell

| Shell Size | Part Number      | L Max. | M +.000 - .005 | N +.001 - .005 | P Max. Panel Thickness | R (TP) | S +.011 - .010 | T Dia. ±.005 | KK Dia. +.006 - .005 | SS Dia. +.000 - .016 | Z                     |                   |
|------------|------------------|--------|----------------|----------------|------------------------|--------|----------------|--------------|----------------------|----------------------|-----------------------|-------------------|
|            |                  |        |                |                |                        |        |                |              |                      |                      | Size 16 & 20 Contacts | Size 22D Contacts |
| 9          | 88/91-569711-XXX | .203   | .820           | .572           | .234                   | .719   | .938           | .128         | .433                 | .662                 | .454 - .401           | .468 - .406       |
| 11         | 712-XXX          | .203   | .820           | .700           | .234                   | .812   | 1.031          | .128         | .557                 | .810                 | .454 - .401           | .468 - .406       |
| 13         | 713-XXX          | .203   | .820           | .850           | .234                   | .906   | 1.125          | .128         | .676                 | .960                 | .454 - .401           | .468 - .406       |
| 15         | 714-XXX          | .203   | .820           | .975           | .234                   | .969   | 1.219          | .128         | .801                 | 1.085                | .454 - .401           | .468 - .406       |
| 17         | 715-XXX          | .203   | .820           | 1.100          | .234                   | 1.062  | 1.312          | .128         | .926                 | 1.210                | .454 - .401           | .468 - .406       |
| 19         | 716-XXX          | .203   | .820           | 1.207          | .234                   | 1.156  | 1.438          | .128         | 1.032                | 1.317                | .454 - .401           | .468 - .406       |
| 21         | 717-XXX          | .234   | .790           | 1.332          | .204                   | 1.250  | 1.562          | .128         | 1.157                | 1.442                | .454 - .401           | .468 - .406       |
| 23         | 718-XXX          | .234   | .790           | 1.457          | .204                   | 1.375  | 1.688          | .147         | 1.282                | 1.567                | .454 - .401           | .468 - .406       |
| 25         | 719-XXX          | .234   | .790           | 1.582          | .193                   | 1.500  | 1.812          | .147         | 1.407                | 1.692                | .454 - .401           | .468 - .406       |

All dimensions for reference only.  
Z dimension is determined by contact type in the insert arrangement.  
Most common options are shown; other options are available.

- III 38999
- II I SJT
- Matrix 2 26482
- Matrix Pyle 83723 III
- Release Matrix 5015 Crimp Rear
- 26500 Pyle

- Printed Circuit Board
- EMI Filter Transient
- Fiber Optics
- High Speed Contacts
- Options Others

**(Back Panel Mounting) (With Clinch Nuts)**

**Series I LJT**

| ZZ      |            |
|---------|------------|
| Pins    |            |
| 12      | .176/.115  |
| 16      | .044/-.007 |
| 20      | .161/.100  |
| 22D     | .092/.031  |
| Sockets |            |
| 12      | .176/.112  |
| 16      | .092/.038  |
| 20      | .161/.097  |
| 22D     | .200/.129  |

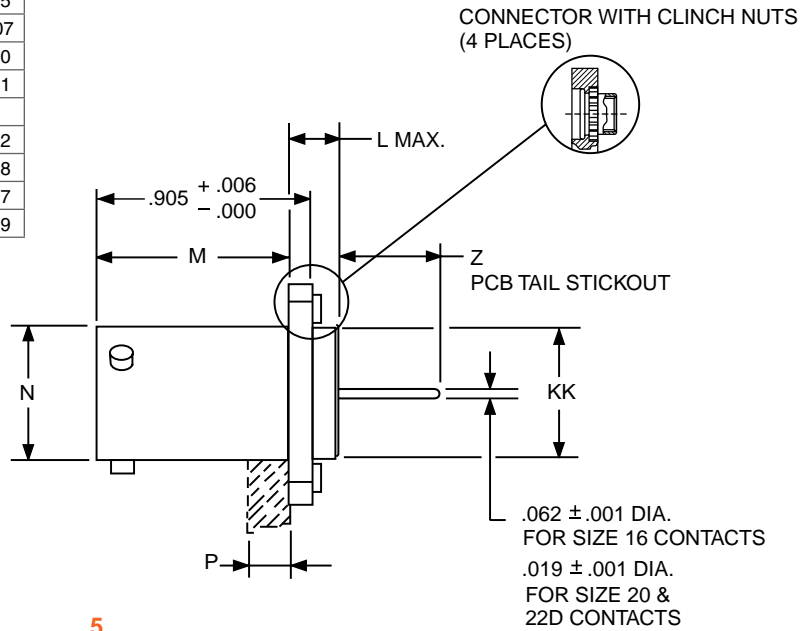
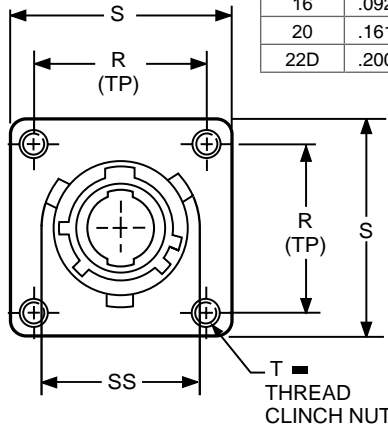

| PART #<br>See chart below | 1.           | 2.          | 3.               | 4.                 | 5.                                 |
|---------------------------|--------------|-------------|------------------|--------------------|------------------------------------|
|                           | Shell Finish | Base Number | Coded Shell Size | Insert Arrangement | Contact Type/Alt. Keying Positions |
|                           | 88/91        | 628         | 711              | -35                | P                                  |

**HOW TO ORDER**

**1. Select a Shell Finish:**

|           |  |
|-----------|--|
| <b>88</b> | Designates olive drab cadmium plated connector shell |
| <b>91</b> | Designates electroless nickel plated connector shell |

**2. Base Number:**

|            |             |
|------------|-------------|
| <b>628</b> | Base Number |
|------------|-------------|

**3. Select a Coded Shell Size:**

See chart below **711-719**, designates size 9-25 shell size.  
Example: **711**= Size 9 Shell

**4. Select an Insert Arrangement:**

Refer to insert availability chart on page 239 and pin-out illustrations on pages 241-255. In the chart the first number represents the Shell size and the second number is the insert Arrangement.

|            |                                      |
|------------|--------------------------------------|
| <b>-35</b> | Designates Insert Arrangement Number |
|------------|--------------------------------------|

**5. Contact Type/Alternate Keying Positions:**

Refer to page 240 for alternate rotation letters to use.

|          |   |
|----------|---|
| <b>P</b> | Designates Pin Contacts in Normal Position    |
| <b>S</b> | Designates Socket Contacts in Normal Position |

■ (+) .005 DIA (M)

| Shell Size | Part Number with Clinch Nuts | L Max. | M +.000 / -.005 | N +.001 / -.005 | P Max. Panel Thickness | R (TP) | S +.011 / -.010 | T Thread       | KK Dia. +.006 / -.005 | SS Dia. +.000 / -.016 | Z                     |                   |
|------------|------------------------------|--------|-----------------|-----------------|------------------------|--------|-----------------|----------------|-----------------------|-----------------------|-----------------------|-------------------|
|            |                              |        |                 |                 |                        |        |                 |                |                       |                       | Size 16 & 20 Contacts | Size 22D Contacts |
| 9          | 88/91-628711-XXX             | .203   | .820            | .572            | .234                   | .719   | 1.031           | .112-40UNJC-3B | .433                  | .662                  | .454 - .401           | .468 - .406       |
| 11         | <b>712</b> -XXX              | .203   | .820            | .700            | .234                   | .812   | 1.125           | .112-40UNJC-3B | .557                  | .810                  | .454 - .401           | .468 - .406       |
| 13         | <b>713</b> -XXX              | .203   | .820            | .850            | .234                   | .906   | 1.172           | .112-40UNJC-3B | .676                  | .960                  | .454 - .401           | .468 - .406       |
| 15         | <b>714</b> -XXX              | .203   | .820            | .975            | .234                   | .969   | 1.281           | .112-40UNJC-3B | .801                  | 1.085                 | .454 - .401           | .468 - .406       |
| 17         | <b>715</b> -XXX              | .203   | .820            | 1.100           | .234                   | 1.062  | 1.375           | .112-40UNJC-3B | .926                  | 1.210                 | .454 - .401           | .468 - .406       |
| 19         | <b>716</b> -XXX              | .203   | .820            | 1.207           | .234                   | 1.156  | 1.469           | .112-40UNJC-3B | 1.032                 | 1.317                 | .454 - .401           | .468 - .406       |
| 21         | <b>717</b> -XXX              | .234   | .790            | 1.332           | .204                   | 1.250  | 1.625           | .112-40UNJC-3B | 1.157                 | 1.442                 | .454 - .401           | .468 - .406       |
| 23         | <b>718</b> -XXX              | .234   | .790            | 1.457           | .204                   | 1.375  | 1.750           | .138-32UNJC-3B | 1.282                 | 1.567                 | .454 - .401           | .468 - .406       |
| 25         | <b>719</b> -XXX              | .234   | .790            | 1.582           | .193                   | 1.500  | 1.875           | .138-32UNJC-3B | 1.407                 | 1.692                 | .454 - .401           | .468 - .406       |

All dimensions for reference only.

\*Consult Amphenol for more information on ordering connectors with clinch nuts. There is also a 3mm clinch nut available (part number 88/91-628410/149)

Z dimension is determined by contact type in the insert arrangement.

Most common options are shown; other options are available.



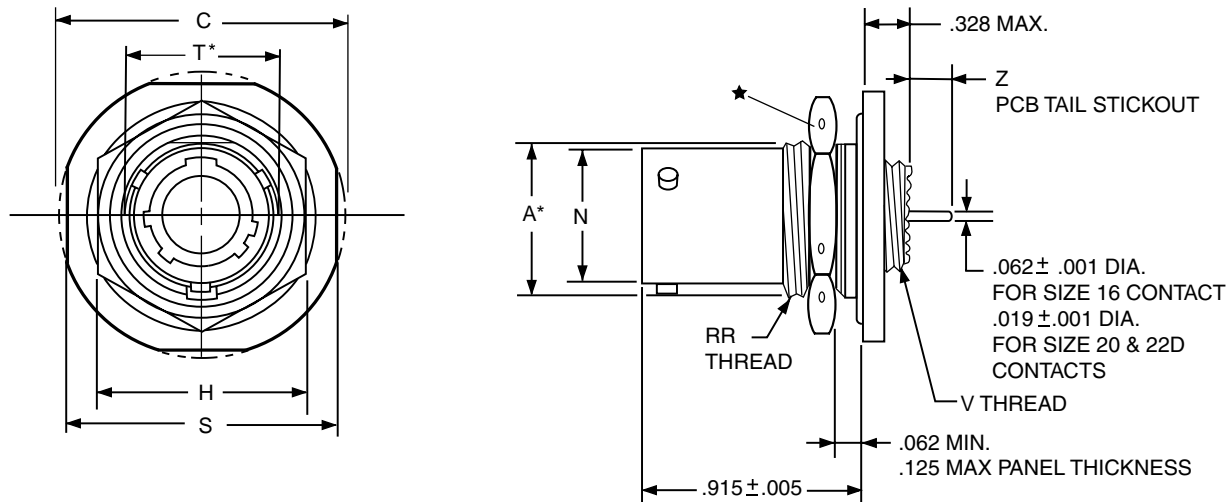

| PART #          | 1. Shell Finish | 2. Base Number | 3. Coded Shell Size | 4. Insert Arrangement | 5. Contact Type/Alt. Keying Positions |
|-----------------|-----------------|----------------|---------------------|-----------------------|---------------------------------------|
| See chart below | 88/91           | 569            | 721                 | -35                   | P                                     |

### HOW TO ORDER

#### 1. Select a Shell Finish:

|    |  |
|----|--|
| 88 | Designates olive drab cadmium plated connector shell |
| 91 | Designates electroless nickel plated connector shell |

#### 2. Base Number:

|     |             |
|-----|-------------|
| 569 | Base Number |
|-----|-------------|

#### 3. Select a Coded Shell Size:

See chart below **721-729**, designates size 9-25 shell size.  
Example: **721**= Size 9 Shell

| Shell Size | Part Number      | A*<br>+.000<br>-.010 | C<br>Max. | H Hex<br>+.017<br>-.016 | L<br>Max. | N<br>+.001<br>-.005 | S<br>±.016 | T*<br>+.010<br>-.000 | VThread<br>Class 2A<br>(Plated) | RRThread<br>Class 2A<br>(Plated) | Z                           |                      |
|------------|------------------|----------------------|-----------|-------------------------|-----------|---------------------|------------|----------------------|---------------------------------|----------------------------------|-----------------------------|----------------------|
|            |                  |                      |           |                         |           |                     |            |                      |                                 |                                  | Size<br>16 & 20<br>Contacts | Size 22D<br>Contacts |
| 9          | 88/91-569721-XXX | .669                 | 1.199     | .875                    | .625      | .572                | 1.062      | .697                 | .4375-28 UNEF                   | .6875-24 UNEF                    | .229 - .175                 | .243 - .182          |
| 11         | 722-XXX          | .769                 | 1.386     | 1.000                   | .625      | .700                | 1.250      | .822                 | .5625-24 UNEF                   | .8125-20 UNEF                    | .229 - .175                 | .243 - .182          |
| 13         | 723-XXX          | .955                 | 1.511     | 1.188                   | .625      | .850                | 1.375      | 1.007                | .6875-24 UNEF                   | 1.0000-20 UNEF                   | .229 - .175                 | .243 - .182          |
| 15         | 724-XXX          | 1.084                | 1.636     | 1.312                   | .625      | .975                | 1.500      | 1.134                | .8125-20 UNEF                   | 1.1250-18 UNEF                   | .229 - .175                 | .243 - .182          |
| 17         | 725-XXX          | 1.208                | 1.761     | 1.438                   | .625      | 1.100               | 1.625      | 1.259                | .9375-20 UNEF                   | 1.2500-18 UNEF                   | .229 - .175                 | .243 - .182          |
| 19         | 726-XXX          | 1.333                | 1.949     | 1.562                   | .656      | 1.207               | 1.812      | 1.384                | 1.0625-18 UNEF                  | 1.3750-18 UNEF                   | .207 - .158                 | .221 - .165          |
| 21         | 727-XXX          | 1.459                | 2.073     | 1.688                   | .750      | 1.332               | 1.938      | 1.507                | 1.1875-18 UNEF                  | 1.5000-18 UNEF                   | .207 - .158                 | .221 - .165          |
| 23         | 728-XXX          | 1.580                | 2.199     | 1.812                   | .750      | 1.457               | 2.062      | 1.634                | 1.3125-18 UNEF                  | 1.6250-18 UNEF                   | .207 - .158                 | .221 - .165          |
| 25         | 729-XXX          | 1.709                | 2.323     | 2.000                   | .750      | 1.582               | 2.188      | 1.759                | 1.4375-18 UNEF                  | 1.7500-18 UNS                    | .207 - .158                 | .221 - .165          |

All dimensions for reference only.  
Z dimension is determined by contact type in the insert arrangement.  
Most common options are shown; other options are available.

★ .059 dia. min. 3 lockwire holes.  
Formed lockwire hole design (6 holes) is optional.  
\* "D" shaped mounting hole dimensions

38999  
SJT

26482  
Matrix 2

83723 III  
Pyle

5015  
Crimp Rear  
Release Matrix

26500 Pyle

Printed  
Circuit Board

EMI Filter  
Transient

Fiber Optics

High Speed  
Contacts

Options  
Others

### Series I LJT

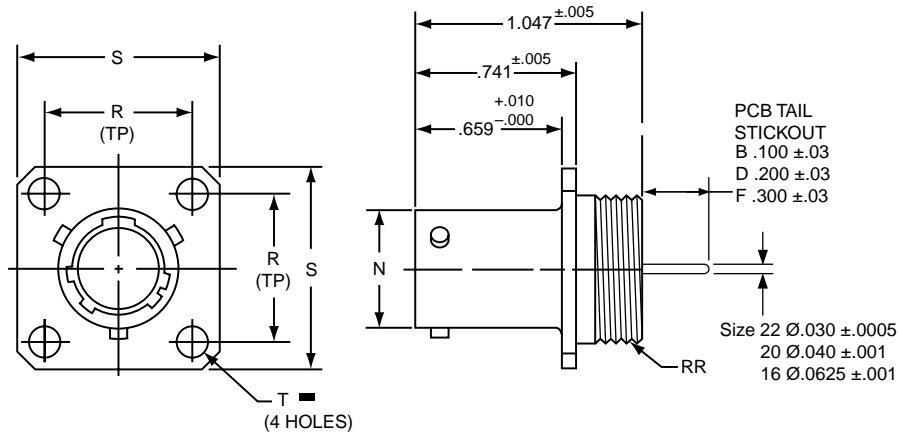

| PART #          | 1. Base Number | 2. Coded Shell Size | 3. Contact Type/Alt. Keying Positions | 4. Shell Finish | 5. Tail Length |
|-----------------|----------------|---------------------|---------------------------------------|-----------------|----------------|
| See chart below | 10-626         | 401                 | P                                     | 1               | B              |

### HOW TO ORDER

#### 1. Base Number:

|               |   |
|---------------|---|
| <b>10-626</b> | Base Number for MIL-DTL-38999 Series III Hermetic with PCB Tail |
|---------------|---|

#### 4. Select a Shell Finish:

|   |  |
|---|--|
| 1 | Hermetic seal, passivated Stainless Steel, 200°C |
| 2 | Hermetic seal, Stainless Steel w/Nickel Plate    |

#### 2. Select a Coded Shell Size:

See chart below **401-409**, designates size 9-25 shell size

#### 3. Contact Type/Alternate Keying Positions:

Refer to page 240 for alternate rotation letters to use.

|          |   |
|----------|---|
| <b>P</b> | Designates Pin Contacts in Normal Position    |
| <b>S</b> | Designates Socket Contacts in Normal Position |

#### 5. Select a Tail Length:

|   |          |
|---|----------|
| B | .100±.03 |
| D | .200±.03 |
| F | .300±.03 |

■  $\text{⊕} \text{ } .005 \text{ DIA } \text{ (M)}$

| Shell Size | Part Number   | N Dia. +.001 –.005 | R (TP) | S ±.016 | T Dia. ±.005 | RR Thread Class 2A |
|------------|---------------|--------------------|--------|---------|--------------|--------------------|
| 9          | 10-626401-XXX | .572               | .719   | .938    | .128         | .6875-24 UNEF      |
| 11         | 402-XXX       | .700               | .812   | 1.031   | .128         | .8125-20 UNEF      |
| 13         | 403-XXX       | .850               | .906   | 1.125   | .128         | .9375-20 UNEF      |
| 15         | 404-XXX       | .975               | .969   | 1.219   | .128         | 1.0625-18 UNEF     |
| 17         | 405-XXX       | 1.100              | 1.062  | 1.312   | .128         | 1.1875-18 UNEF     |
| 19         | 406-XXX       | 1.207              | 1.156  | 1.438   | .128         | 1.3125-18 UNEF     |
| 21         | 407-XXX       | 1.332              | 1.250  | 1.562   | .128         | 1.4375-18 UNEF     |
| 23         | 408-XXX       | 1.457              | 1.375  | 1.688   | .147         | 1.5625-18 UNEF     |
| 25         | 409-XXX       | 1.582              | 1.500  | 1.812   | .147         | 1.6875-18 UNEF     |

All dimensions for reference only.

Printed Circuit Board

EMI Filter Transient

Fiber Optics

High Speed Contacts

Options Others

# 38999, Series I Hermetic – PCB Contacts

## LJT07 Jam Nut Receptacle

Series I LJT

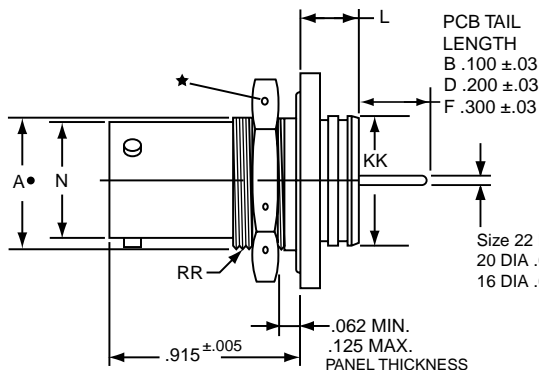
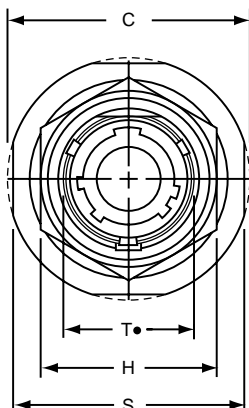

|             |                  |                                    |              |             |
|-------------|------------------|------------------------------------|--------------|-------------|
| 1.          | 2.               | 3.                                 | 4.           | 5.          |
| Base Number | Coded Shell Size | Contact Type/Alt. Keying Positions | Shell Finish | Tail Length |
| 10-626      | 41               | P                                  | 1            | B           |

**PART #**  
See chart below

Follow HOW TO ORDER instructions below

| Shell Size | Part Number   | A*<br>+.000<br>-.010 | C<br>Max. | H Hex<br>+.017<br>-.016 | L<br>Max. | N<br>+.000<br>-.005 | S<br>±.016 | T*<br>+.010<br>-.000 | KK<br>+.011<br>-.000 | RR Thread<br>Class 2A<br>(Plated) |
|------------|---------------|----------------------|-----------|-------------------------|-----------|---------------------|------------|----------------------|----------------------|-----------------------------------|
| 9          | 10-626411-XXX | .669                 | 1.199     | .875                    | .297      | .572                | 1.062      | .697                 | .642                 | .6875-24 UNEF                     |
| 11         | 412-XXX       | .769                 | 1.386     | 1.000                   | .297      | .700                | 1.250      | .822                 | .766                 | .8125-20 UNEF                     |
| 13         | 413-XXX       | .955                 | 1.511     | 1.188                   | .297      | .850                | 1.375      | 1.007                | .892                 | 1.0000-20 UNEF                    |
| 15         | 414-XXX       | 1.084                | 1.636     | 1.312                   | .297      | .975                | 1.500      | 1.134                | 1.018                | 1.1250-18 UNEF                    |
| 17         | 415-XXX       | 1.208                | 1.761     | 1.438                   | .297      | 1.100               | 1.625      | 1.259                | 1.142                | 1.2500-18 UNEF                    |
| 19         | 416-XXX       | 1.333                | 1.949     | 1.562                   | .328      | 1.207               | 1.812      | 1.384                | 1.268                | 1.3750-18 UNEF                    |
| 21         | 417-XXX       | 1.459                | 2.073     | 1.688                   | .328      | 1.332               | 1.938      | 1.507                | 1.392                | 1.5000-18 UNEF                    |
| 23         | 418-XXX       | 1.580                | 2.199     | 1.812                   | .328      | 1.457               | 2.062      | 1.634                | 1.518                | 1.6250-18 UNEF                    |
| 25         | 419-XXX       | 1.709                | 2.328     | 2.000                   | .328      | 1.582               | 2.188      | 1.759                | 1.642                | 1.7500-18 UNS                     |

All dimensions for reference only.

# 38999, Series I Hermetic – PCB Contacts

## LJTI Solder Mounting Receptacle

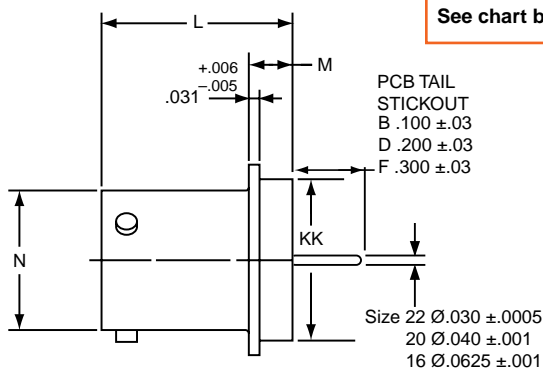
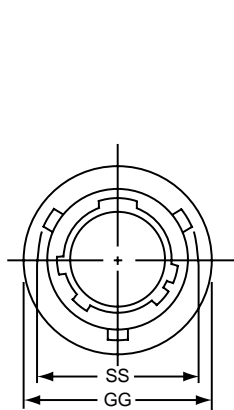

|             |                  |                                    |              |             |
|-------------|------------------|------------------------------------|--------------|-------------|
| 1.          | 2.               | 3.                                 | 4.           | 5.          |
| Base Number | Coded Shell Size | Contact Type/Alt. Keying Positions | Shell Finish | Tail Length |
| 10-626      | 42               | P                                  | 1            | B           |

**PART #**  
See chart below

### HOW TO ORDER

- Base Number:**  
10-626 Base Number for MIL-DTL-38999 Series III Hermetic with PCB Tail
- Select a Coded Shell Size:**  
See chart below 421-429, designates size 9-25 shell size
- Contact Type/Alt. Keying Positions:**  
Refer to page 240 for alternate rotation letters to use.  

|   |   |
|---|---|
| P | Designates Pin Contacts in Normal Position    |
| S | Designates Socket Contacts in Normal Position |
- Select a Shell Material**

|   |  |
|---|--|
| 1 | Hermetic seal, passivated Stainless Steel, 200°C |
| 2 | Hermetic seal, Stainless Steel w/Nickel Plate    |
- Select a Tail Length:**

|   |          |
|---|----------|
| B | .100±.03 |
| D | .200±.03 |
| F | .300±.03 |

| Shell Size | Part Number   | N Dia.<br>+.001<br>-.005 | SS Dia.<br>+.000<br>-.016 | L<br>+.011<br>-.000 | M<br>+.006<br>-.005 | GG Dia.<br>+.011<br>-.010 | KK Dia.<br>+.001<br>-.005 |
|------------|---------------|--------------------------|---------------------------|---------------------|---------------------|---------------------------|---------------------------|
| 9          | 10-626421-XXX | .572                     | .662                      | .789                | .125                | .750                      | .672                      |
| 11         | 422-XXX       | .700                     | .810                      | .789                | .125                | .844                      | .781                      |
| 13         | 423-XXX       | .850                     | .960                      | .789                | .125                | .969                      | .906                      |
| 15         | 424-XXX       | .975                     | 1.085                     | .789                | .125                | 1.094                     | 1.031                     |
| 17         | 425-XXX       | 1.100                    | 1.210                     | .789                | .125                | 1.218                     | 1.156                     |
| 19         | 426-XXX       | 1.207                    | 1.317                     | .789                | .125                | 1.312                     | 1.250                     |
| 21         | 427-XXX       | 1.332                    | 1.442                     | .789                | .125                | 1.438                     | 1.375                     |
| 23         | 428-XXX       | 1.457                    | 1.567                     | .821                | .156                | 1.563                     | 1.500                     |
| 25         | 429-XXX       | 1.582                    | 1.692                     | .821                | .156                | 1.688                     | 1.625                     |

All dimensions for reference only.  
Weld mounting hermetic receptacle also available.  
Consult Amphenol, Sidney, NY for availability and dimensions.

38999  
SJT

26482  
Matrix 2

83723 III  
Matrix  
Pyle

5015  
Crimp Rear  
Release Matrix

26500 Pyle

Printed  
Circuit Board

EM I Filter  
Transient

Fiber Optics

High Speed  
Contacts

Options  
Others

Series III TV

Series II JT

Series I LJT

Amphenol's stand-off adapter and spanner nut assembly allows any MIL-DTL-38999 jam nut receptacle to support PCB contacts and may eliminate the need for special stand-off shell design. Consult Amphenol for more information.



Tri-Start MIL-DTL-38999 Jam Nut Connector with Stand-off Adapter

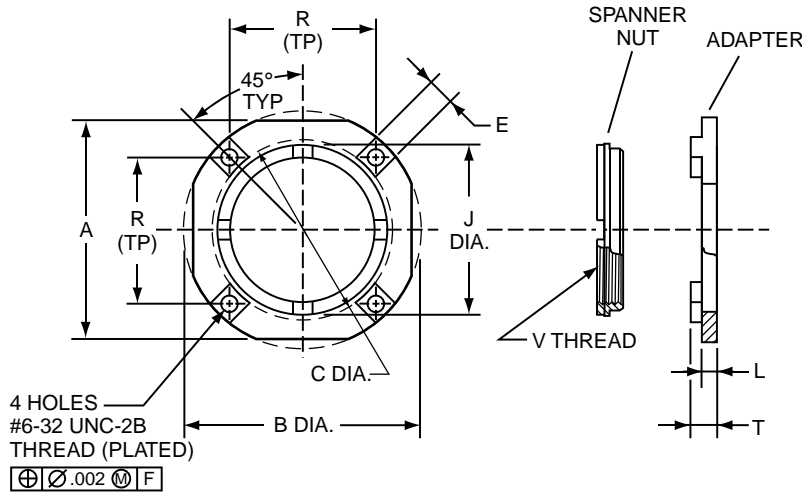

| FINISH DATA**      |   |
|--------------------|---|
| Suffix Designation | Description                                 |
| 9                  | Olive drab cadmium plate, nickel base plate |
| G                  | Electroless nickel plate                    |
| None               | Passivated Stainless Steel                  |
| 8                  | Nickel Plated                               |

\*\* Other finishes available; consult Amphenol for further information.

- HOW TO ORDER
- Order by applicable 10- part number in table below. Last digit designates finish - see finish table.

| Shell Size | Part Number     | A ± .003 | B Dia. ± .003 | C Dia. +.005 -0.001 | E ± .005 | J Dia. +.005 -0.000 | L ± .003 | R (TP) | T* ± .002 | V Thread Metric Plated |
|------------|-----------------|----------|---------------|---------------------|----------|---------------------|----------|--------|-----------|------------------------|
| 9          | 10-658266-01( ) | 1.062    | 1.188         | .750                | .200     | .625                | .150     | .688   | .325      | M12 X 1-6H             |
| 11         | 10-658266-02( ) | 1.250    | 1.375         | .900                | .200     | .744                | .150     | .813   | .325      | M15 X 1-6H             |
| 13         | 10-658266-03( ) | 1.375    | 1.500         | .975                | .200     | .862                | .150     | .860   | .325      | M18 X 1-6H             |
| 15         | 10-658266-04( ) | 1.500    | 1.625         | 1.125               | .200     | 1.019               | .150     | .968   | .325      | M22 X 1-6H             |
| 17         | 10-658266-05( ) | 1.625    | 1.750         | 1.250               | .200     | 1.137               | .150     | 1.062  | .325      | M25 X 1-6H             |
| 19         | 10-658266-06( ) | 1.812    | 1.938         | 1.375               | .200     | 1.255               | .150     | 1.188  | .325      | M28 X 1-6H             |
| 21         | 10-658266-07( ) | 1.938    | 2.062         | 1.469               | .200     | 1.373               | .150     | 1.250  | .325      | M31 X 1-6H             |
| 23         | 10-658266-08( ) | 2.062    | 2.188         | 1.625               | .200     | 1.492               | .150     | 1.344  | .325      | M34 X 1-6H             |
| 25         | 10-658266-09( ) | 2.188    | 2.312         | 1.750               | .200     | 1.610               | .150     | 1.438  | .325      | M37 X 1-6H             |
| 9          | 10-658266-10( ) | 1.062    | 1.188         | .750                | .200     | .625                | .150     | .688   | .362      | M12 X 1-6H             |
| 11         | 10-658266-11( ) | 1.250    | 1.375         | .900                | .200     | .744                | .150     | .813   | .362      | M15 X 1-6H             |
| 13         | 10-658266-12( ) | 1.375    | 1.500         | .975                | .200     | .862                | .150     | .860   | .362      | M18 X 1-6H             |
| 15         | 10-658266-13( ) | 1.500    | 1.625         | 1.125               | .200     | 1.019               | .150     | .968   | .362      | M22 X 1-6H             |
| 17         | 10-658266-14( ) | 1.625    | 1.750         | 1.250               | .200     | 1.137               | .150     | 1.062  | .362      | M25 X 1-6H             |
| 19         | 10-658266-15( ) | 1.812    | 1.938         | 1.375               | .200     | 1.255               | .150     | 1.188  | .362      | M28 X 1-6H             |
| 21         | 10-658266-16( ) | 1.938    | 2.062         | 1.469               | .200     | 1.373               | .150     | 1.250  | .362      | M31 X 1-6H             |
| 23         | 10-658266-17( ) | 2.062    | 2.188         | 1.625               | .200     | 1.492               | .150     | 1.344  | .362      | M34 X 1-6H             |
| 25         | 10-658266-18( ) | 2.188    | 2.312         | 1.750               | .200     | 1.610               | .150     | 1.438  | .362      | M37 X 1-6H             |

All dimensions for reference only.

\* For information on additional "T" dimension lengths, consult Amphenol.

Consult Amphenol Aerospace in Sidney, NY for stainless steel availability & part numbers.

# Amphenol EMI/EMP Filter Protection



**New  
Featured**



Planar Array  
Assembly



Capacitor and  
MOV Planars



Diode Contacts



## TABLE OF CONTENTS

### EMI/EMP Filter Protection Connectors - For Protection of Sensitive Circuits

- Table of Contents. . . . . 277
- Filter Product Overview, Advantages . . . . . 278
- EMI Capabilities . . . . . 279, 280
- Filter Connector Options/Selection Data . . . . . 281, 282
- Effect of Temperature on EMI Filter, Filter Attenuation Curves . . . . . 283
- Impedance Matching Formula . . . . . 284
- Quality Assurance Testing . . . . . 285
- How to Order . . . . . 286-289
- Filter connectors with High Density Patterns . . . . . 289

### Filter Connector Shell Styles:

- Filter MIL-DTL-38999, Series III - FTV Aluminum / FCTV Composite . . . . . 290
  - Composite Shell Styles FCTV . . . . . 291-294
  - Aluminum Shell Styles FTV . . . . . 295-300
- Filter MIL-DTL-38999, Series II - FJT Aluminum . . . . . 301-307
- Filter MIL-DTL-38999, Series I - FLJT Aluminum . . . . . 308-317
- Filter SJT Series (MIL-DTL-38999 type) - FSJT Aluminum . . . . . 318-321
- Filter MIL-DTL-38999 Series IV - FBL Aluminum . . . . . 322, 323
- Filter MIL-DTL-26482/MIL-DTL-83723 - FPT Aluminum . . . . . 324-329
- Filter "AN" Series, MIL-DTL-5015 - FAN Aluminum . . . . . 330, 331
- Filter Adapters . . . . . 332
- Transient Protection MOV (Metal Oxide Varistor) Connectors . . . . . 333, 334
- Transient Protection Diode Connectors . . . . . 335, 336
- Transient Protection ESA (Energy Shunting Assembly) Connectors. . . . . 337
- EMI/Transient Protection Specials . . . . . 338



### EMI/EMP Filter Connector Typical Markets:

- Military & Commercial Aviation
- Military Vehicles
- Missiles & Ordnance
- Space & Satellites
- C4ISR





Amphenol® EMI/EMP Protection Connectors offer the versatility of standard connectors with EMI/EMP protection for sensitive circuits. Internal housing of the EMI/EMP devices eliminates costly and bulky exterior discrete protection devices.

**Virtually all major MIL-Spec circulars can be incorporated with filter devices:**

- MIL-DTL-38999
- MIL-DTL-5015
- MIL-DTL-26482
- MIL-DTL-27599
- MIL-DTL-83723
- MIL-DTL-26500

**Amphenol offers filter connectors that include:**

- EMP protection using diodes
- EMP protection utilizing metal oxide varistors (MOV's)
- Filtered plug connectors
- Filtered hermetic connectors
- Filter connectors with ESD protection
- EMI & EMP Protected Connectors
- Combinations of filtering devices within one connector package

This catalog focuses on the cylindrical connector offerings from Amphenol with EMI/EMP filter transient protection. There are also many rectangular filter connectors that are offered by Amphenol which include:

- MIL-DTL-24308 D-Sub
- MIL-DTL-83513 Micro D
- ARINC 404/600
- DOD-83527 Rack and Panel
- MIL-DTL-83733 Rack and Panel

Rectangular filter interconnects are manufactured and supplied by Amphenol Canada ([www.amphenolcanada.com](http://www.amphenolcanada.com)).

**Advantages of Filter Connectors:**

- Reduction in overall weight and space with the elimination of external filter circuits
- Reduction of solder junctions
- Increase in reliability due to fewer connections
- Fragile filter elements protected from handling and environmental damage
- Pre-testing from factory and ready for installation

38999  
SJT I II III

26482  
Matrix 2

83723 III  
Matrix Pyle

5015  
Crimp Rear  
Release Matrix

26500 Pyle

Printed  
Circuit Board

EMI Filter  
Transient

Fiber Optics

High Speed  
Contacts

Options  
Others

**FTV**  
Subminiature Tri-Start, MIL-DTL-38999 Series III, Metal or Composite shells with Filter Protection.

**FLJT**  
Subminiature LJT, MIL-DTL-38999 Series I with Filter Protection.

**Filter AN Connector**  
MIL-DTL-5015 Type Connectors with Filter Protection. See Catalog 12-120

**FJT**  
Subminiature JT, MIL-DTL-38999 Series II with Filter Protection.

**FCTV with Stand-off Flange**  
Filtered Tri-Start connectors with composite shells for attachment to printed circuit boards.

**FPT**  
Miniature MIL-DTL-26482 Series I with Filter Protection. See Catalog 12-120

**Filter Contacts Combined with High Speed Contacts**  
Filter Connectors can incorporate high frequency coax, twinax, triax, quadrax and differential twinax contacts.

**MOV Connectors**  
MOV's act as a variable resistor to efficiently dissipate energy. MOV can be packaged singularly or in combinations with other EMI

**Header Assemblies**  
Allow for easy separation and easy termination of connectors when attaching to flex or printed circuit boards. Allow for electrical testing that would adversely affect sensitive diodes, MOV's or filter capacitors.



The Amphenol® EMI filter connector utilizes two manufacturing technologies to provide the user with the most cost effective performance across the frequency range. (For EMP performance data, see pages 332-336).

The tubular design offers over 40 years of proven field reliability. All filter contacts within the connector share a common ground plane, which is connected to the connector shell. The pin to pin isolation is 85 dB minimum at 100 MHz. The planar design joins pins to a multi-layered ceramic, forming an array sub-assembly with a peripheral ground. This is connected to the connector shell via a ground spring. Pin to pin capacitance is less than 50 pf with a pin-to-pin isolation of 85 dB minimum at 100 MHz. Filter contacts for both designs contain either a pi passive element network comprised of a ferrite inductor and ceramic capacitor, or a single capacitor.

For planar designs, other filter networks are available, ie. T Type, L-C Type, C-L Type and C Type. An encapsulant of oven-cured epoxy in the rear provides:

- Mechanical and thermal insulation of the ceramic elements – mechanical loading can be accomplished without capacitor damage. Pins can be bent 90° and straightened with no damage to the filter.
- Hermeticity ( $4.6 \times 10^{-3}$  cc/sec) – prevents water from entering through the rear of the connector in high humidity environments. Amphenol recommends using metal protection caps during cleaning operations.

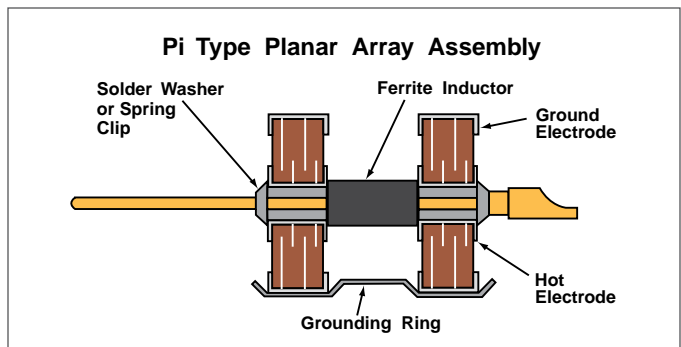
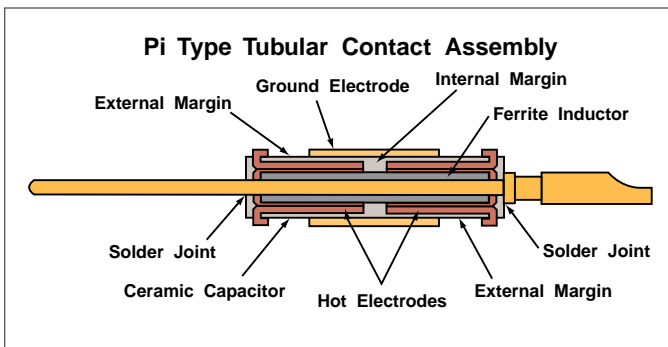
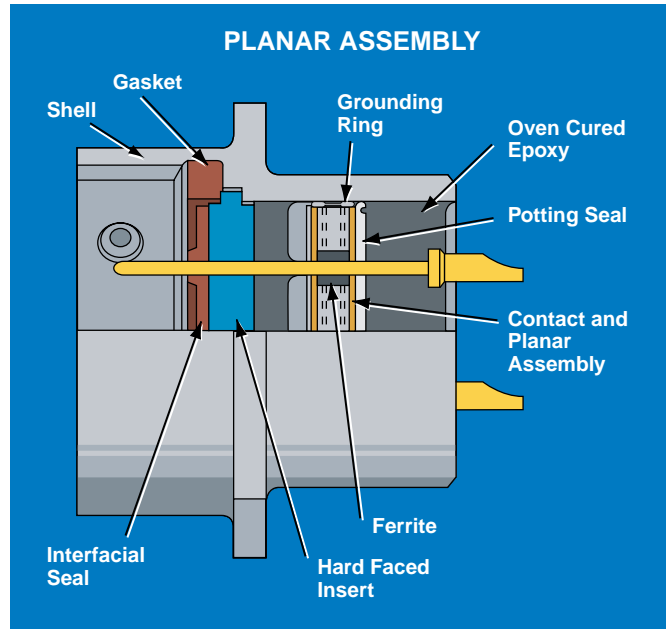
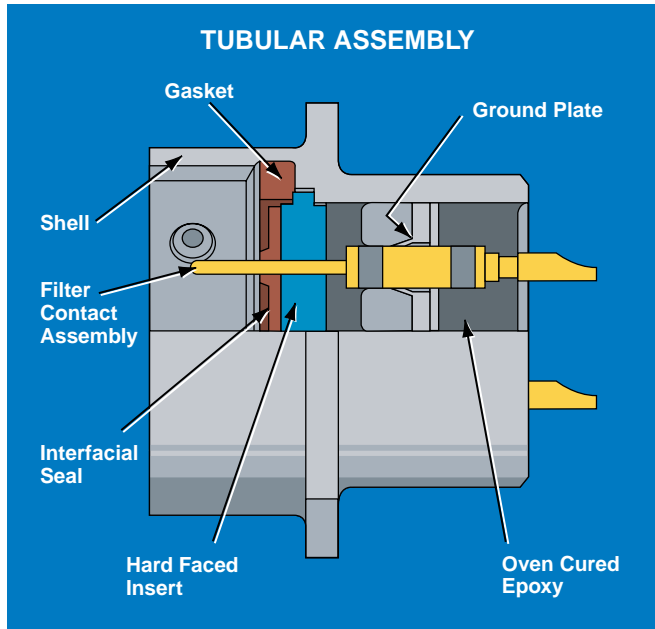

III  
II  
I  
SJT  
38999

Matrix 2  
26482

Matrix Pyle  
83723 III

Crimp Rear Release Matrix  
5015

Pyle  
26500

Printed Circuit Board

EMI Filter Transient

Fiber Optics

High Speed Contacts

Options Others

38999  
SJT I II III

Amphenol provides a wide range of filtering solutions. You can select your options for your particular interference threats - VHF, UHF, HF or other filter ranges, then couple with a connector package of your choice. Or give Amphenol your custom shell design requirements for assistance in designing your unique filter solution.

26482  
Matrix 2

EMI Filter connectors are intended for use in temperatures from -55°C to +125°C. Attenuation will change with feed-through current and temperature.\*

83723 III  
Matrix Pyle

To assure reliability, connectors may be subjected to an attenuation performance test verifying proper assembly and grounding of the filters. Attenuation data on filter performance is stated in reference to a 50 ohm impedance system in order to allow filter performance to be more easily translated into real world impedances. Those interested in determining the expected filter performance in an impedance system other than 50 ohms may refer to page 284 of this catalog or may contact Amphenol Aerospace for further assistance.

5015  
Crimp Rear Release Matrix

26500 Pyle

**It is suggested that the user analyze his system requirements for EMI protection in the following areas:**

- Working voltage (DC or AC and Frequency)
- Peak voltage
- Desired attenuation at a given frequency level
- Any special capacitance limitations

Printed  
Circuit Board

**Definition of Filter Contacts:**

|              |  |
|--------------|--|
| <b>MF-1</b>  | Medium Frequency<br>50 dB performance between 300 - 2999 KHz     |
| <b>HF-1</b>  | High Frequency<br>50 dB performance between 3 - 29 MHz           |
| <b>VHF-1</b> | Very High Frequency<br>50 dB performance between 30 - 2999 MHz   |
| <b>UHF-1</b> | Ultra High Frequency<br>50 dB performance between 300 - 2999 MHz |

Filter contacts can be provided in most frequencies in contact sizes 22 or larger. Consult Amphenol Aerospace for availability.

Tubular connector designs will meet 3 amps RF current from -55°C through +125°C. Planar connector designs will meet 5 amps.

\* More in-depth information on attenuation is available in: L-1146, General Design Guideline for EMI Filters and/or TVS (Transient Voltage Suppression) Connectors.

Also for further information ask for: L-1145, How to Specify Filter Connectors.

EMI Filter  
Transient

Fiber Optics

High Speed  
Contacts

Options  
Others

**Planars, MOV's, Tubular and Diode Contacts**



**Planar Array Assembly**

**Capacitor and MOV Planars**

**Tubular Filters and Diode Contacts**

**Contact Options**

- Coaxial, concentric twinax, triax and quadax contacts can be included in arrangements of filtered contacts for signal or power circuits (Please refer to the High Speed Contacts Section for High Frequency Contacts for Multi-Pin Connectors).
- Filter contacts with differing cut-off frequencies can be mixed in any given insert arrangement. (ratio 100:1 typical)
- Ground, insulated or filter contacts can be combined within the same connector to meet unique or changing frequency protection requirements.
- Thermocouple contacts
- Diodes for EMP

**Methods of Wire Termination**

- Solder cup - wire termination
- PCB termination (Pre-tinning is available)
- Solderless wrap
- Amphenol® UTS (Universal Termination System) allows crimp termination. It uses crimp insertable socket contacts on conductor wires. Sockets mate with filter pins within the connector body. (Socket type M39029/57). (For further contact information, see section, MIL-DTL-38999 Series I & II).
- Weld terminal for thermocouple contacts

## Adapters

Filter adapters eliminate replacement of either existing mated pair. The adapter provides the circuit protection at the MF, VHF and UHF levels, and is an effective and economical method of introducing EMI/EMP protection to an installed system. Adapters are to be placed between mating faces. (See pages 332).

## Printed Circuit Board Mount

Receptacle shell modifications that allow mounting directly to a PC board or flex header. Stand-off shells are available in different configurations. These offer improved reliability by eliminating external spacers and washers. (See pages 293, 294, 299, 300, 313 and 316).

## Hermetic

The hermetic filter connector, while only approximately 1/2 inch longer than standard series connectors, provides all the benefits of a hermetic connector, plus EMI protection for sensitive circuits. The filter assembly is protected by a fused glass insert within a unique steel housing. This design provides the capability to tolerate high level static pressure while maintaining a low level leakage rate. More information on Hermetics is given on page 423.

## Composite

Composite shell filter connectors meet the MIL-DTL-38999, Series III dimensional length, and offer a light-weight, corrosion resistant, durable connector with the same high performance features as its metal counterpart. The composite filter connector utilizes planar technology to accommodate VHF-1 or better electrical performance characteristics. (See FCTV Composites on pages 290-294).

## ESD Protection

Filter connectors with ESD (Electrostatic Discharge) protection are available. These MIL-DTL-38999 Series I and III connectors have an added feature of a Faraday Cage to shunt electrostatic discharge events to the conductive enclosure on which the connector is mounted. (See page 422).

## Filtered Plugs

Filtered Plugs are designed for applications where EMI protection is essential, but access to the receptacle is denied. Designed with the same components as a standard filter receptacle, the filtered plug offers the option of being mounted on the cable harness. It is a cost effective method of achieving EMI protection when length restrictions prohibit inclusion of an adapter to the system. Consult Amphenol Aerospace for availability.

## Diode Connectors

Diode Connectors offer versatility with transient protection for sensitive circuits, such as TTL lines. Diodes can stand alone or be combined with other filters. (Pages 335-336).

## Shunting Assembly

Amphenol's Energy Shunting Assembly is a simple, compact unit which provides lightning and electromagnetic pulse protection of systems in which many signal lines enter sensitive electronic equipment. (Page 337).



Circular Filter Protection Connectors are offered in a wide range of styles, with custom designs for special applications.



Filter Adapters can be attached to connectors to provide EMI/EMP protection.



Hermetic filter connector



Composite stand-off shell Filter 38999 connector

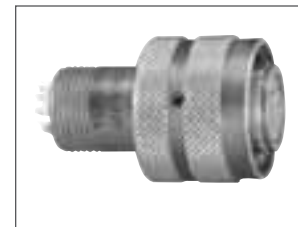

Filtered plug



Diode Connectors



ESA - Energy Shunting Assembly

|     |                           |
|-----|---------------------------|
| III | 38999                     |
| II  | 26482                     |
| I   | Matrix 2                  |
| SJT | 83723 III                 |
|     | Matrix Pyle               |
|     | 5015                      |
|     | Crimp Rear Release Matrix |
|     | 26500 Pyle                |
|     | Printed Circuit Board     |

|                     |
|---------------------|
| EMI Filter          |
| Transient           |
| Fiber Optics        |
| High Speed Contacts |
| Options Others      |

38999 SJT I II III  
26482 Matrix 2  
83723 III Pyle Matrix  
5015 Crimp Rear Release Matrix  
26500 Pyle  
Printed Circuit Board  
EMI Filter Transient  
Fiber Optics  
High Speed Contacts  
Options Others

Amphenol® EMI Connectors are produced with several types of filters. They are all low band pass filters with the following configurations:

**Pi -**

Typical of the VHF, UHF and MF filter

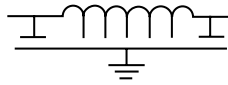

**Cascaded Pi -**

Typical of the HF filter. It consists of two VHF Pi filters on a common pin and is available in tubular designs only.

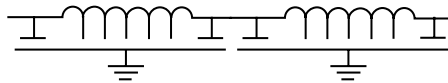

**Capacitor \*-**

Consists of a feed-through capacitor without any ferrite. It can be 50pf to 1µf and carry the MF, HF and VHF designation depending on its typical 50dB performance.

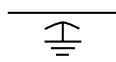

**L-C \*-**

Typical of HF, VHF and UHF filter. Low source / high load impedance.



**C-L \*-**

Typical of HF, VHF and UHF filter. High load impedance / low source.



**T \*-**

Typical of HF, VHF and UHF filter. Low source / low load impedance.

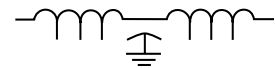

\* Consult factory for attenuation performance values.

| Parameters   |                  | Medium Frequency Filter       | High Frequency Filter | Very High Frequency Filter |                | Ultra High Frequency Filter |                |
|--|------------------|-------------------------------|-----------------------|----------------------------|----------------|-----------------------------|----------------|
|  |                  | MF-1 (Pi)                     | HF-1 (Cascaded Pi)    | VHF-1 (Pi)                 | VHF-2† (Pi)    | UHF-1† (Pi)                 | UHF-2† (Pi)    |
| Minimum Attenuation (Test Points)*   | 150kHz           | 20dB                          | -                     | -                          | -              | -                           | -              |
|  | 15MHz            | -                             | 50dB                  | -                          | -              | -                           | -              |
|  | 50MHz            | -                             | 80dB                  | -                          | -              | -                           | -              |
|  | 100MHz           | 80dB                          | -                     | 62dB                       | 46dB           | 18dB                        | 28dB           |
| Maximum Working Voltage (User must specify DC or AC)††††   | DC†††            | 50VDC                         | 200VDC                | 200VDC                     | 200VDC         | 200VDC                      | 200VDC         |
| Dielectric Withstanding Voltage Capability (for 5 sec. with 10 milliamperes max. charging current)◆◆ |                  | 100 volts DC                  | 500 volts DC          | 500 volts DC               | 500 volts DC   | 500 volts DC                | 500 volts DC   |
| Maximum Feed-thru Current (DC and/or Audio Frequency R.M.S.)   | Size 16 contacts | 13.0 amps                     | 13.0 amps             | 13.0 amps                  | 13.0 amps      | 13.0 amps                   | 13.0 amps      |
|  | Size 20 contacts | 7.5 amps                      | 7.5 amps              | 7.5 amps                   | 7.5 amps       | 7.5 amps                    | 7.5 amps       |
|  | Size 22 contacts | not available                 | not available         | 5.0 amps                   | 5.0 amps       | 5.0 amps                    | 5.0 amps       |
| Maximum RF Current   |                  | 3.0 amps                      | 3.0 amps              | 3.0 amps                   | 3.0 amps       | 3.0 amps                    | 3.0 amps       |
| Minimum Insulation Resistance  |                  | 250 megohms                   | 10 gigaohms           | 10 gigaohms                | 10 gigaohms    | 10 gigaohms                 | 10 gigaohms    |
| Typical Capacitance**  |                  | 1.0 microfarad                | 16 nanofarads         | 7 nanofarads               | 2.5 nanofarads | 375 picofarads              | 710 picofarads |
| Air Leakage††  |                  | 4.6 x 10 <sup>-3</sup> cc/sec |                       |                            |                |                             |                |
| Operating Temperature Range  |                  | -55°C to +125°C               |                       |                            |                |                             |                |

\* When tested at 25°C per MIL-STD-220.  
 \*\* When measured at a frequency of 1 ±.1kHz and a voltage not exceeding 1.0 V.A.C.R.M.S. at +25°C.  
 † Consult Amphenol, Sidney, NY or your Amphenol representative for part number.  
 †† Lower leakage rates are available upon request.  
 ††† Summation of the DC and low level AC super-imposed peak voltage.  
 †††† Consult Amphenol, Sidney, NY whenever AC voltage is present.  
 ◆ Consult Amphenol, Sidney, NY or your Amphenol representative for availability.  
 ◆◆ Higher DWV ratings are available upon request. Consult Amphenol, Sidney, NY.

Note: Below are typical capacitance values. Other capacitance values are available from 5pf to 400 NF in one capacitor element. Please consult factory for part numbers.

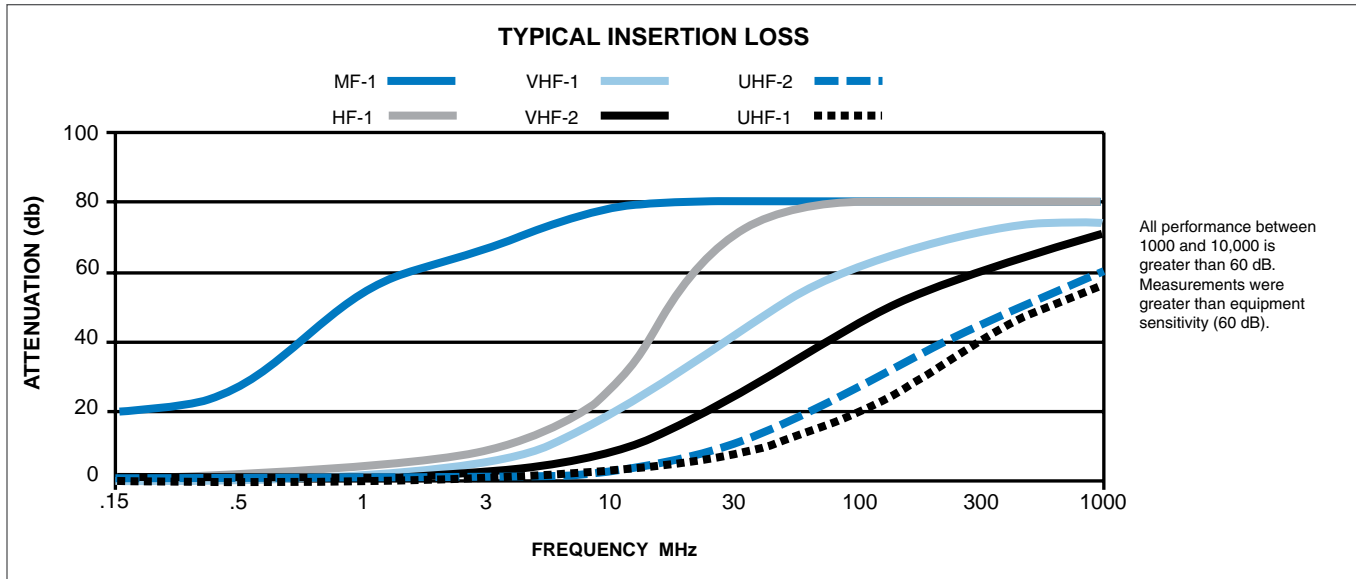

**TYPICAL INSERTION LOSS (dB)  
PER MIL-STD-220, 5 ADC, 25°C**

| Capacitance              | 1MHz | 3MHz | 10MHz | 30MHz | 100MHz | 300MHz | 1000MHz |
|--------------------------|------|------|-------|-------|--------|--------|---------|
| 375 pf UHF <sub>1</sub>  | 0    | 0    | 1     | 8     | 16     | -      | -       |
| 750 pf UHF <sub>2</sub>  | 0    | 0    | 3     | 10    | 19     | -      | -       |
| 2500 pf VHF <sub>2</sub> | 0    | 2    | 8     | 20    | 28     | -      | -       |
| 7000 pf VHF <sub>1</sub> | 5    | 9    | 17    | 23    | 40     | -      | -       |
| 16000 pf HF <sub>1</sub> | 6    | 14   | 20    | 24    | 80     | -      | -       |

Most filter attenuation curves and capacitance values are expressed at 25°C. However, temperature can affect the capacitance of a titanate filter element, affecting the insertion loss that the element will cause.

In order to assist the user in anticipating the effect of various temperatures, the following charts applicable to Amphenol® filter connectors utilizing MF-1, HF-1, VHF-1, VHF-2, UHF-1 and UHF-2 filters are provided. Please note that all insertion loss (attenuation) values given were measured with no load applied. The band designations refer to MIL-STD-2120.

**MF-1\***

Typical Capacitance = 1,000,000 pf Min. 800,000 pf Max. 1,600,000 pf Type Pi

| Temp.  | F <sub>co</sub> | 1MHz | 3MHz | 10MHz | 30MHz | 100MHz | 300MHz | 1000MHz |
|--------|-----------------|------|------|-------|-------|--------|--------|---------|
| -55°C  | -               | 18   | -    | 64    | 80    | 80     | 80     | 80      |
| Room   | 7.94K           | 55   | -    | 80    | 80    | 80     | 80     | 80      |
| +125°C | -               | 22   | -    | 70    | 80    | 80     | 80     | 80      |

**VHF-2**

Typical Capacitance = 2,500 pf Min. 1,900 pf Max. 4,000 pf Band E, Type Pi

| Temp.  | F <sub>co</sub> | 1MHz | 3MHz | 10MHz | 30MHz | 100MHz | 300MHz | 1000MHz |
|--------|-----------------|------|------|-------|-------|--------|--------|---------|
| -55°C  | -               | 0    | 2    | 7     | 17    | 40     | 58     | 71      |
| Room   | 3.3M            | 0    | 2    | 8     | 24    | 46     | 61     | 71      |
| +125°C | -               | 0    | 3    | 10    | 26    | 46     | 63     | 69      |

**HF-1\***

Typical Capacitance = 16,000 pf Min. 9,800 pf Max. 24,000 pf Type Cascaded Pi

| Temp.  | F <sub>co</sub> | 1MHz | 3MHz | 15MHz | 50MHz | 100MHz | 300MHz | 1000MHz |
|--------|-----------------|------|------|-------|-------|--------|--------|---------|
| -55°C  | -               | 2    | 6    | 24    | 62    | 80     | 80     | 80      |
| Room   | 648K            | 3    | 9    | 50    | 80    | 80     | 80     | 80      |
| +125°C | -               | 0    | 6    | 30    | 62    | 80     | 80     | 80      |

**UHF-2**

Typical Capacitance = 750 pf Min. 500 pf Max. 1,100 pf Band C, Type Pi

| Temp.  | F <sub>co</sub> | 1MHz | 3MHz | 10MHz | 30MHz | 100MHz | 300MHz | 1000MHz |
|--------|-----------------|------|------|-------|-------|--------|--------|---------|
| -55°C  | -               | 0    | 0    | 3     | 9     | 25     | 46     | 61      |
| Room   | 12.7M           | 0    | 0    | 3     | 10    | 28     | 46     | 61      |
| +125°C | -               | 0    | 0    | 3     | 10    | 24     | 42     | 60      |

**VHF-1**

Typical Capacitance = 7,000 pf Min. 4,900 pf Max. 12,000 pf Band G, Type Pi

| Temp.  | F <sub>co</sub> | 1MHz | 3MHz | 10MHz | 30MHz | 100MHz | 300MHz | 1000MHz |
|--------|-----------------|------|------|-------|-------|--------|--------|---------|
| -55°C  | -               | 1    | 2    | 8     | 21    | 44     | 61     | 65      |
| Room   | 1.27M           | 1    | 6    | 18    | 42    | 62     | 72     | 75      |
| +125°C | -               | 0    | 2    | 9     | 24    | 45     | 62     | 64      |

**UHF-1**

Typical Capacitance = 375 pf Min. 290 pf Max. 450 pf Band B, Type Pi

| Temp.  | F <sub>co</sub> | 1MHz | 3MHz | 10MHz | 30MHz | 100MHz | 300MHz | 1000MHz |
|--------|-----------------|------|------|-------|-------|--------|--------|---------|
| -55°C  | -               | 0    | 0    | 1     | 6     | 21     | 43     | 58      |
| Room   | 21.9M           | 0    | 0    | 1     | 8     | 18     | 42     | 56      |
| +125°C | -               | 0    | 0    | 1     | 8     | 17     | 38     | 50      |

Note: F<sub>co</sub> = Cut-off Frequency

\* Consult Amphenol, Sidney, NY for availability.

- III 38999
- II 26482
- I Matrix 2
- SJT 83723 III
- Matrix Pyle
- 5015 Crimp Rear Release Matrix
- 26500 Pyle
- Printed Circuit Board
- EMI Filter Transient
- Fiber Optics
- High Speed Contacts
- Options Others



38999  
SJT I II III

26482  
Matrix 2

83723 III  
Matrix Pyle

5015  
Crimp Rear  
Release Matrix

26500 Pyle

Printed  
Circuit Board

EMI Filter  
Transient

Fiber Optics

High Speed  
Contacts

Options  
Others

The following formula and example are offered in order to determine the expected filter performance in an impedance system other than 50 ohms.

With the attenuation expressed in 50 ohms and the transfer impedance curve shown in Figure 1 below, a designer can relate the expressed attenuation to the input and output impedance of his circuit.

Example:

- (1) Noise is 40dB above specification level at 100 MHz
- (2) Input and output impedance are 10 and 100 ohms respectively
- (3) Amphenol® VHF 7000 pf filter has a 65 dB minimum attenuation at 100 MHz and +25°C

Formula (Taken from Figure 1):

1.4 x 10 ohm = transfer impedance  
for 65 dB in a 50 ohm system

$$\text{Atten (dB)} = 20 \log_{10} \left[ 1 + \frac{Z_s Z_L}{Z_{12}(Z_s + Z_L)} \right]$$

$Z_s$  = source impedance

$Z_L$  = load impedance

$Z_{12}$  = transfer impedance

Atten = filter performance in a system other than 50 ohms

$$\text{Atten (dB)} = 20 \log_{10} \left[ 1 + \frac{10(100)}{1.4 \times 10^{-2} (10 + 100)} \right]$$

Attenuation = 56.3dB

In this case, the 7000 pf VHF filter will give 56.3 dB which is 16.3dB below the desired reduction in noise (40dB) as stated in the above problem.

**Attenuation vs Transfer Impedance in 50 Ohm System**

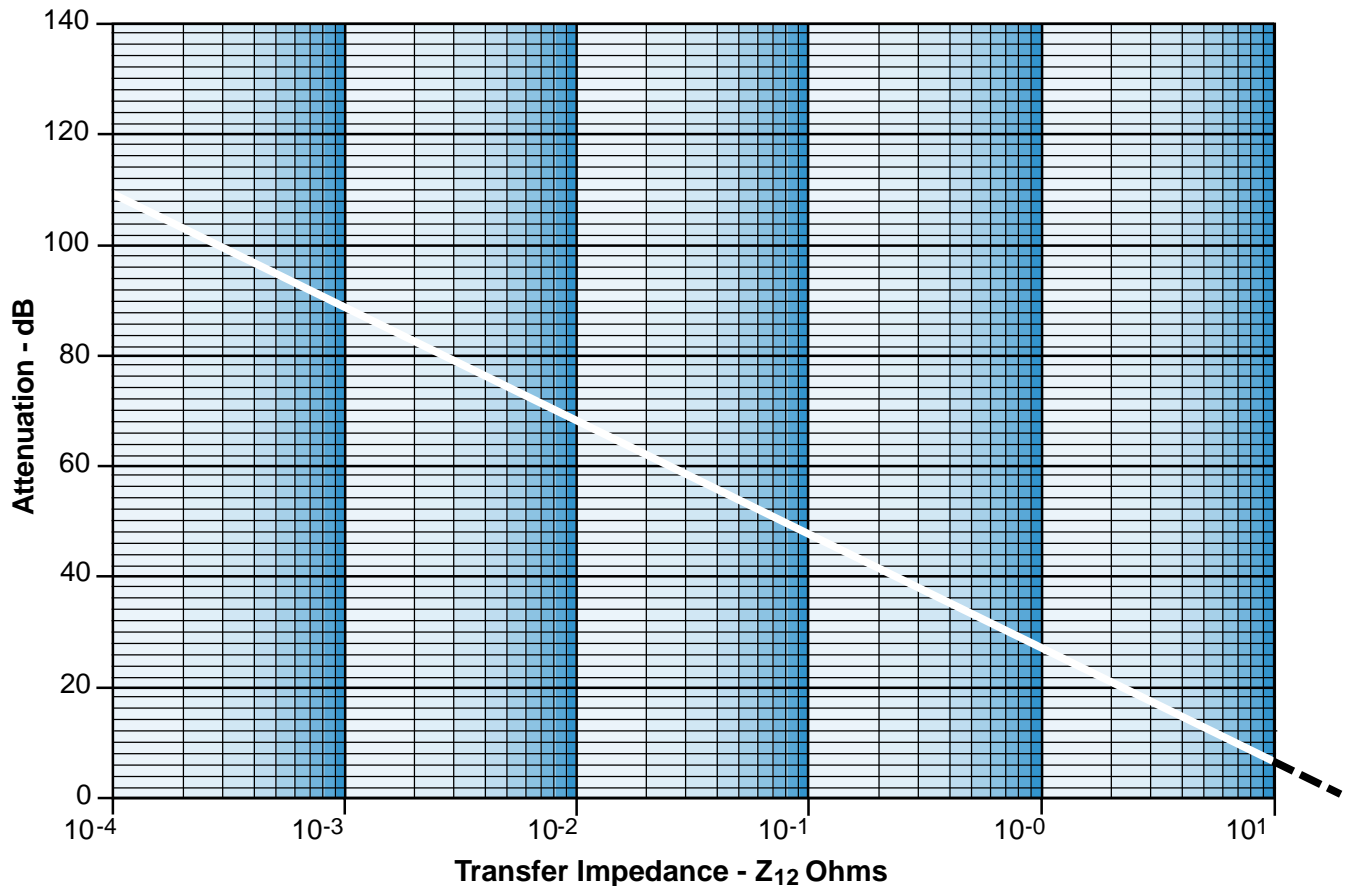

Figure 1



## ACCEPTANCE TESTING

All filter connectors undergo extensive acceptance testing to assure product quality. An outline of standard acceptance testing performed is as follows:

### Mechanical Inspection

- Dimensional inspection of shells, keys, keyways and mounting surfaces by either in-process inspection of components or inspection of final assemblies.
- Visual inspection of contacts, inserts and seals, gaskets and surface finish of shells and hardware.

### Electrical Tests

- Insulation resistance of filter contacts is checked 100% **at the working voltage and to the test limit** listed for each filter in the filter selection data table.
- Dielectric withstanding voltage is tested on 100% of filter contacts at the voltage listed in the filter selection data table.
- Capacitance is tested 100% at 1KHz.

## Special Tests/Processes

In addition to the standard acceptance testing and processes, the following additional production testing and processing can be provided upon request:

- Attenuation testing (through 100 MHz)
- Leakage inspection
- Thermal cycling/shock
- Burn-in
- De-gassing

Consult Amphenol Aerospace for further information.

## Qualifications

Amphenol® filter connectors have been qualified and are on periodic requalification to specification BSF-1 (available from your Amphenol representative). This is patterned after MIL-DTL-38999, modified to include mechanical and environmental testing and electrical parameters important to filter connector performance.

These acceptance tests, along with exhaustive in-process inspection and testing, give Amphenol® filter connectors their reputation for reliability.

### ATTENUATION TEST CIRCUIT

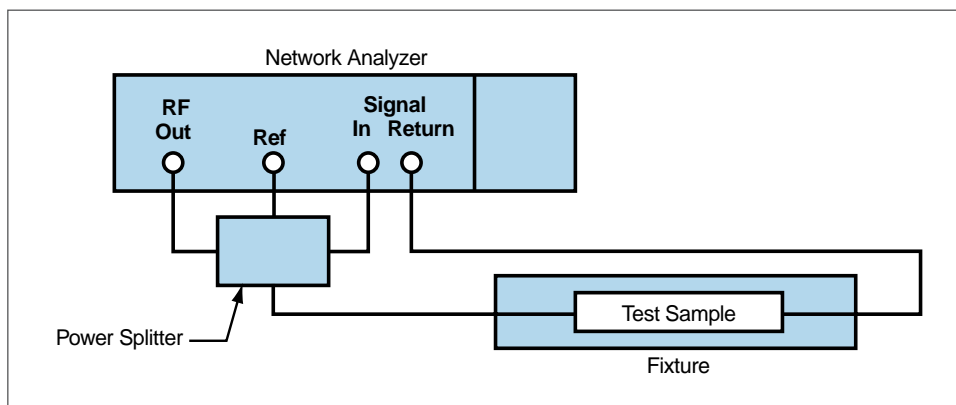

There are multiple test stations located on the Amphenol production floor that support all in-process, final electric and qualification testing as necessary.

38999  
III II I SJT

26482  
Matrix 2

83723 III  
Matrix Pyle

5015  
Crimp Rear Release Matrix

26500 Pyle

Printed  
Circuit Board

EMI Filter  
Transient

Fiber Optics

High Speed  
Contacts

Options  
Others

### Step 1.

#### Fill out the EMI Filter Connector Check list on page 287.

This check list page can be copied, filled out and sent to an Amphenol technical support person. Fax it to 607-563-5157 and a filter connector specialist will help you.

### Step 2.

#### Choose the Contact and Attenuation Characteristics requirements on page 283 and 284

### Step 3.

#### Choose the Shell Style that fits your application

Refer to each of the style sections in this catalog.

| Filter Connector Type | Filter Connector Brief Description                   | Pages   |
|-----------------------|--|---------|
| FCTV                  | MIL-DTL-38999 Series III with Composite shell        | 290-294 |
| FTV                   | MIL-DTL-38999 Series III with Metal shell (Aluminum) | 295-300 |
| FJT                   | MIL-DTL-38999, Series II                             | 301-307 |
| FLJT                  | MIL-DTL-38999 Series I                               | 308-317 |
| FSJT                  | Commercial 38999 type                                | 318-321 |
| FBL                   | MIL-DTL-38999, Series IV                             | 322-324 |
| FPT                   | MIL-DTL-26482  | 324-329 |
| FAN                   | MIL-DTL-5015   | 330-331 |



### Step 4.

#### See How to Order on page 288, 289

**How to Order Filter**

Easy Steps to build a part number... Filter

**Step 1: Connector Type**

**Step 2: Connector/Filter Type**

**Step 3: Connector/Filter Type Continue**

**Step 4: Select a Shell Finish**

**Step 5: Select a Shell Style**

Amphenol Aerospace

38999  
SJT I II III

26482  
Matrix 2

83723 III  
Matrix Pyle

5015  
Crimp Rear Release Matrix

26500 Pyle

Printed  
Circuit Board

EMI Filter  
Transient

Fiber Optics

High Speed  
Contacts

Options  
Others

# How to Order

## EMI Filter Check List



### 1. Fill out the EMI Filter Connector Check list

Date \_\_\_\_\_

Ref. Filter P/N \_\_\_\_\_ Ref. Mil-Spec \_\_\_\_\_

**Filter Requirements:**

Filter Type (Pi, C, LC, T, LL, other) \_\_\_\_\_

Capacitance (locations) \_\_\_\_\_

Capacitance (locations) \_\_\_\_\_

Capacitance (locations) \_\_\_\_\_

Ground Contacts (locations) \_\_\_\_\_

Insulated feed-thru (locations) \_\_\_\_\_

| Frequency (MHz) | Insertion Loss (dB) |
|-----------------|---------------------|
| 1               |                     |
| 3               |                     |
| 10              |                     |
| 30              |                     |
| 100             |                     |

**Electrical Requirements:**

Working Voltage (VDC or VAC and frequency) \_\_\_\_\_

Dielectric Withstand Voltage (VDC) \_\_\_\_\_

**Modified Shell:** (Flange moved, clinch nuts, heilicoils, stand offs, etc.) \_\_\_\_\_

**Special Requirements:** (AC voltage, spike voltage, attenuation testing, thermal cycling, burn-in, capacitor lot traceability, water immersion, etc.) \_\_\_\_\_

**Contact Termination:**

UTS (Crimp) \_\_\_\_\_

Solder Cup \_\_\_\_\_

Wire Wrap Flat dim. \_\_\_\_\_  
Stickout dim. \_\_\_\_\_

PCB tail:

Diameter dim. \_\_\_\_\_

Stickout dim. \_\_\_\_\_

Pre-tin? \_\_\_\_\_

What is terminated to connector (ie. flex, rigid flex, PCB, etc.)? \_\_\_\_\_

Special Cleaning \_\_\_\_\_  
(if so, recommend a protective cap with an environmental gasket)

**Special Stamping:** \_\_\_\_\_

**Customer:** \_\_\_\_\_

**Program:** \_\_\_\_\_

**Forecast:** \_\_\_\_\_

**Requested by:** \_\_\_\_\_

**Comments:** \_\_\_\_\_

III 38999  
II  
I  
SJT

Matrix 2 26482

Matrix 83723 III  
Pyle

5015  
Crimp Rear  
Release Matrix

26500 Pyle

Printed  
Circuit Board

EMI Filter  
Transient

Fiber Optics

High Speed  
Contacts

Options  
Others

Fax a completed copy to 607-563-5157

### Easy Steps to build a part number... Filter

- 1.
- 2.
- 3.
- 4.
- 5.
- 6.

| Filter Connector Designator | Connector and Filter Type | Shell Finish | Shell Styles | Shell Size – Insert Arrg. | Type of Contact and Keyway Position |
|-----------------------------|---------------------------|--------------|--------------|---------------------------|-------------------------------------|
| 21                          | 24                        | 9            | 2            | 16-26                     | P                                   |

#### Step 1. Select a Connector Type

|    | Designates Filter Connector |
|----|-----------------------------|
| 21 | Filter Connector            |
| 36 | MOV Connector               |
| 47 | Diode Connector             |

#### Step 2. Select a Connector/Filter Type

|    | Designates  |
|----|---|
| 20 | FPT with VHF-1 filter (short shell)                               |
| 22 | FPTE with VHF-1 filter (short shell)                              |
| 24 | FJT with VHF-1 filter (short shell)                               |
| 25 | FJT with ±8 volt diode/VHF-1 filter combination                   |
| 26 | FAN with VHF-1 filter   |
| 29 | FLJT with VHF-1 filter (short shell)                              |
| 31 | FPT with MF-1 filter (short shell)                                |
| 32 | FJT with MF-1 filter (short shell)                                |
| 33 | FPT with HF-1 filter (long shell)                                 |
| 34 | FJTP with VHF-1 filter (short shell)                              |
| 36 | FLJT with HF-1 filter (long shell)                                |
| 37 | FJT with HF-1 filter (long shell-min. penetration also available) |
| 38 | FJTP with HF-1 filter (long shell)                                |
| 39 | FJTP with MF-1 filter (short shell)                               |
| 40 | FLJT with MF-1 filter (short shell)                               |
| 41 | FJT (UTS) with VHF-1 filter (short shell)                         |
| 46 | FPT (UTS) with VHF-1 filter                                       |
| 47 | FLJTPQ with VHF-1 filter (short shell)                            |
| 48 | FLJTPQ (UTS) with VHF-1 filter (short shell)                      |
| 50 | FTV (UTS) with VHF-1 filter (short shell)                         |
| 51 | FTV (UTS) with HF-1 filter (long shell)                           |
| 52 | FTV with VHF-1 filter (short shell)                               |
| 53 | FTV with HF-1 filter (long shell)                                 |
| 56 | FJTP (UTS) with VHF-1 filter                                      |
| 57 | FLJT with VHF-1 filter (printed circuit mount)                    |
| 58 | FJTPQ (UTS) with VHF-1 filter (short shell)                       |
| 60 | FTV with VHF-1 filter (printed circuit board mount, mod. flange)  |
| 61 | FBL with VHF-1 filter (short shell)                               |
| 63 | FSJT with VHF-1 filter (short shell)                              |
| 64 | FBL (UTS) with VHF-1 filter                                       |
| 65 | FSJT (UTS) with VHF-1 filter                                      |
| 67 | FTV with VHF-1 filter (printed circuit board mount, Std. flange)  |
| 68 | FTV (UTS) with ±8 volt diode/VHF-1 filter combination             |

#### Step 2., Continues Select Connector/Filter Type

|    | Designates  |
|----|---|
| 73 | M83723 bayonet coupling with VHF-1 filter                         |
| 76 | FCTV with VHF-1 filter with composite shell                       |
| 77 | FTV with VHF-1 filter and standard series III shells              |
| 78 | FCTV PCB mount with standard flange and VHF-1 filter              |
| 79 | Same as 77 with no filter - Epoxy sealed                          |
| 80 | FTV PCB mount with standard flange, standard nut and VHF-1 filter |
| 82 | FTV with ±8 volt diode/VHF-1 filter combination                   |
| 83 | FSJT with ±8 volt diode/VHF-1 filter combination                  |
| 84 | FTV (UTS) with ±8 volt diode only                                 |
| 87 | FLJT (UTS) with ±8 volt diode/VHF-1 filter combination            |

#### Step 3. Select a Shell Finish

|   | Designates   |
|---|--|
| 0 | Chromate   |
| 1 | Bright cadmium   |
| 2 | Stainless steel (electrolytic nickel plated)                     |
| 4 | Electroless nickel, MS (F)                                       |
| 5 | Gold plate over nickel   |
| 7 | Cadmium plate over nickel, MS (A)                                |
| 8 | Bright nickel  |
| 9 | Cadmium plate, nickel base, OD, MS(B), (500 hr. salt spray test) |
| D | Duralon™ Nickel-PTFE (cadmium alternative)                       |

#### Step 4. Select a Shell Style

|   | Designates                                    |
|---|---|
| 0 | Wall mount receptacle                         |
| 2 | Box mount receptacle                          |
| 3 | Jam nut receptacle with rear thread (PT only) |
| 4 | Minimum penetration jam nut receptacle        |
| 7 | Jam nut receptacle                            |

See page 332 for ordering Filter Adapters.  
Federal Vendor Identification/FSCM 77820

38999  
SJT I II III

26482  
Matrix 2

83723 III  
Matrix Pyle

5015  
Crimp Rear Release Matrix

26500 Pyle

Printed  
Circuit Board

EMI Filter  
Transient

Fiber Optics

High Speed  
Contacts

Options  
Others

## Step 5. Select a Shell Size & Insert Arrangement

| Shell Size   | Designates   |
|--------------|--|
| 8 through 24 | Shell sizes available for FJT, Series I                      |
| 9 through 25 | Shell sizes available for FLJT, Series II and TV, Series III |

Shell Size & Insert Arrangements are together in one chart. First number represents Shell Size, second number is the Insert Arrangement.

- MIL-DTL-38999 see pages 4-7
- MIL-DTL-26482, Matix Series 2 see page 111 or catalog 12-070 for Series 1
- MIL-DTL-5015, Matrix see pages 172 & 173 or catalog 12-020
- High Density HD38999 Filter Connector in Stand-off shells see page 43 and consult Amphenol Aerospace for ordering information.



NEW High Density Patterns are available in Filter 38999 connectors in standard Mil-Spec or filter length shells. They provide 30% more contacts than standard insert arrangement patterns. Please see page 43 and consult Amphenol Aerospace for ordering Information.

## Step 6. Select the type of Contact and Normal or Alternate Keying Positions

| Shell Size | Designates                  |
|------------|-----------------------------|
| P          | Pins in a normal rotation   |
| S          | Socket in a normal rotation |

For alternate keying positions for each series:

- FTV/CTV see pages 290
- FJT see page 301
- FLJT see page 308
- FSJT see page 318
- FBL see page 322
- FPT see page 324
- FAN see page 330 see page 43 and consult Amphenol Aerospace for ordering information.

### Note:

#### -2XX Suffix

Any combination of filters, non-filters, grounds, and non-standard contact terminations will require -2XX suffix. Please consult Amphenol Aerospace for assistance in setting up these part numbers.

- Standard voltage for diode is ±8 volts. Any deviation requires a -2XX suffix.
- Standard voltage for a MOV is 47 volts. Any deviation requires a -2XX suffix.
- Standard diode/filter combination is ±8 volt/VHF-1 filter. Any deviation requires a -2XX suffix.
- Standard MOV/filter combination is 47 volt/VHF-1 filter. Any deviation requires a -2XX suffix. See page 332 for ordering adapters; page 106, 107 for ordering universal headers.

Record your part numbers here...

| 1.                          | 2.                        | 3.           | 4.           | 5.                               | 6.                                  |
|-----------------------------|---------------------------|--------------|--------------|----------------------------------|-------------------------------------|
| Filter Connector Designator | Connector and Filter Type | Shell Finish | Shell Styles | Shell Size – Insert Arrangements | Type of Contact and Keyway Position |
|                             |                           |              |              |                                  |                                     |
|                             |                           |              |              |                                  |                                     |
|                             |                           |              |              |                                  |                                     |
|                             |                           |              |              |                                  |                                     |
|                             |                           |              |              |                                  |                                     |
|                             |                           |              |              |                                  |                                     |
|                             |                           |              |              |                                  |                                     |

III  
II  
I  
SJT  
38999

Matrix 2  
26482

Matrix  
Pyle  
83723 III

Release Matrix  
Crimp Rear  
5015

Pyle  
26500

Printed  
Circuit Board

EMI Filter  
Transient

Fiber Optics

High Speed  
Contacts

Options  
Others



38999  
SJT I II III

26482  
Matrix 2

83723 III  
Matrix Pyle

5015  
Crimp Rear Release Matrix

26500 Pyle

Printed  
Circuit Board

EMI Filter  
Transient

Fiber Optics

High Speed  
Contacts

Options  
Others

The Amphenol® FTV Series III, demonstrates unsurpassed technical leadership. With added filter features, the high performance general duty threaded connector is designed to withstand the pressures of severe environment applications. The FCTV Series is the Composite Series III with filtering for EMI/EMP protection. It offers the same high performance as its metal counterpart, the FTV, but with a lightweight, corrosion resistance shell.

### FTV & FCTV Composite Intermateable with MIL-DTL-38999 Series III Connectors (See section Series III TV, MIL-DTL-38999)

- Quick Mating - completely mates in a 360° turn of the coupling nut
- Lockwiring Eliminated - incorporates anti-decoupling device
- Contact Protection - 100% "scoop-proof"
- Improved Moisture Resistance - prevents electrolytic erosion of contacts
- Lightweight Composite Shell - 17% – 70% weight savings over metal
- Corrosion Resistant - available in standard MIL-DTL-38999 olive drab cadmium (175°C) and electroless nickel plating (200°C), both withstanding 2000 hours of salt spray exposure. The base material is able to withstand an indefinite exposure to salt spray.
- Durability - 1500 couplings minimum (in reference to connector couplings, not contacts)

#### FTV & FCTV Key/Keyway Positions

| Shell Size | Key & Keyway arrangement identification letter | AR° or AP° BSC | BR° or BP° BSC | CR° or CP° BSC | DR° or DP° BSC |
|------------|--|----------------|----------------|----------------|----------------|
| 9          | N  | 105            | 140            | 215            | 265            |
|            | A  | 102            | 132            | 248            | 320            |
|            | B  | 80             | 118            | 230            | 312            |
|            | C  | 35             | 140            | 205            | 275            |
|            | D  | 64             | 155            | 234            | 304            |
| 11, 13, 15 | N  | 95             | 141            | 208            | 236            |
|            | A  | 113            | 156            | 182            | 292            |
|            | B  | 90             | 145            | 195            | 252            |
|            | C  | 53             | 156            | 220            | 255            |
|            | D  | 119            | 146            | 176            | 298            |
| 17 and 19  | N  | 80             | 142            | 196            | 293            |
|            | A  | 135            | 170            | 200            | 310            |
|            | B  | 49             | 169            | 200            | 244            |
|            | C  | 66             | 140            | 200            | 257            |
|            | D  | 62             | 145            | 180            | 280            |
| 21, 23, 25 | N  | 80             | 142            | 196            | 293            |
|            | A  | 135            | 170            | 200            | 310            |
|            | B  | 49             | 169            | 200            | 244            |
|            | C  | 66             | 140            | 200            | 257            |
|            | D  | 62             | 145            | 180            | 280            |
|            | E  | 79             | 153            | 197            | 272            |

All angles are BSC  
The insert arrangement does not rotate with main key/keyway.



### FTV

Composite FCTV Connector for PCB board mounting. Amphenol is currently the only supplier of one-piece composite PCB stand-off shells.

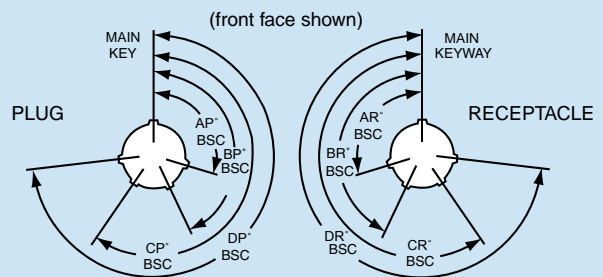

### FCTV





**PART #** To complete, see how to order pages 288-289.

| Filter Connector Designator | Connector Filter Type | Shell Finish | Shell Style | Shell Size & Insert Arrg | Type of Contact/ Keyway Position |
|-----------------------------|-----------------------|--------------|-------------|--------------------------|----------------------------------|
| 21                          | 76                    | X            | 0           | XX-XX                    | X                                |

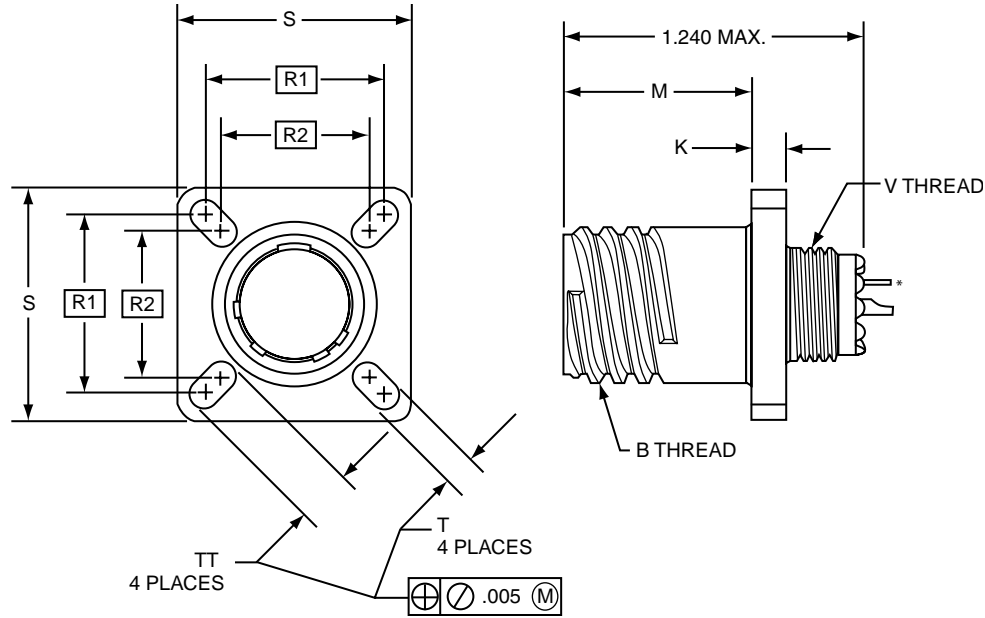

**21-76X0**

\* Printed Circuit Tail available. Consult Amphenol Aerospace factory for Part Number.

| Shell Size | B Thread Class 2A 0.1P-0.3L-TS (Plated) | M +.000 - .005 | K ±.0025 | R <sup>1</sup> TP | R <sup>2</sup> TP | S +.011 - .010 | T +.008 - .006 | TT +.008 - .006 | V Thread Metric (Plated) |
|------------|---|----------------|----------|-------------------|-------------------|----------------|----------------|-----------------|--------------------------|
| 9          | .6250                                   | .773           | .1378    | .719              | .594              | .938           | .128           | .216            | M12X1-6g0.100R           |
| 11         | .7500                                   | .773           | .1378    | .812              | .719              | 1.031          | .128           | .194            | M15X1-6g0.100R           |
| 13         | .8750                                   | .773           | .1378    | .906              | .812              | 1.125          | .128           | .194            | M18X1-6g0.100R           |
| 15         | 1.0000                                  | .773           | .1378    | .969              | .906              | 1.219          | .128           | .173            | M22X1-6g0.100R           |
| 17         | 1.1875                                  | .773           | .1378    | 1.062             | .969              | 1.312          | .128           | .194            | M25X1-6g0.100R           |
| 19         | 1.2500                                  | .773           | .1378    | 1.156             | 1.062             | 1.438          | .128           | .194            | M28X1-6g0.100R           |
| 21         | 1.3750                                  | .741           | .1654    | 1.250             | 1.156             | 1.562          | .128           | .194            | M31X1-6g0.100R           |
| 23         | 1.5000                                  | .741           | .1654    | 1.375             | 1.250             | 1.688          | .154           | .242            | M34X1-6g0.100R           |
| 25         | 1.6250                                  | .741           | .1654    | 1.500             | 1.375             | 1.812          | .154           | .242            | M37X1-6g0.100R           |

All dimensions for reference only.

III  
II  
I  
SJT  
38999

Matrix 2  
26482

Matrix Pyle  
83723 III

Release Matrix  
5015  
Crimp Rear

Pyle  
26500

Printed  
Circuit Board

EMI Filter  
Transient

Fiber Optics

High Speed  
Contacts

Options  
Others

38999  
SJT I II III

26482  
Matrix 2

83723 III  
Matrix Pyle

5015  
Crimp Rear Release Matrix

26500 Pyle

Printed  
Circuit Board

EMI Filter  
Transient

Fiber Optics

High Speed  
Contacts

Options  
Others

**PART #** To complete, see how to order pages 288-289.

| Filter Connector Designator | Connector Filter Type | Shell Finish | Shell Style | Shell Size & Insert Arrg | Type of Contact/ Keyway Position |
|-----------------------------|-----------------------|--------------|-------------|--------------------------|----------------------------------|
| 21                          | 76                    | X            | 7           | XX-XX                    | X                                |

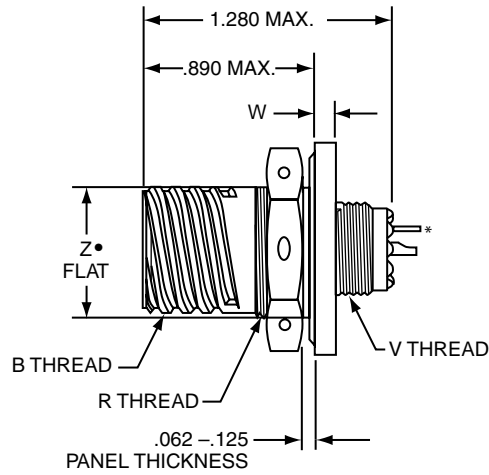
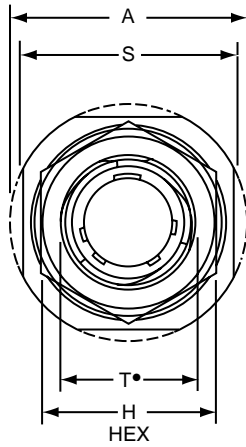

**21-76X7**

\*\* Printed Circuit Tail available. Consult Amphenol Aerospace factory for Part Number.

• D shaped mounting hole dimensions

| Shell Size | A Dia. ±.010 | B Thread Class 2A 0.1P-0.3L-TS (Plated) | H Hex +.017 - .016 | R Thread Metric (Plated) | S ±.015 | T* +.010 - .000 | V Thread Metric (Plated) | W +.035 - .004 | Z* Flat +.000 - .010 |
|------------|--------------|---|--------------------|--------------------------|---------|-----------------|--------------------------|----------------|----------------------|
| 9          | 1.188        | .6250                                   | .875               | M17X1-6g0.100R           | 1.062   | .697            | M12X1-6g0.100R           | .086           | .669                 |
| 11         | 1.375        | .7500                                   | 1.000              | M20X1-6g0.100R           | 1.250   | .822            | M15X1-6g0.100R           | .086           | .769                 |
| 13         | 1.500        | .8750                                   | 1.188              | M25X1-6g0.100R           | 1.375   | 1.007           | M18X1-6g0.100R           | .086           | .955                 |
| 15         | 1.625        | 1.0000                                  | 1.312              | M28X1-6g0.100R           | 1.500   | 1.134           | M22X1-6g0.100R           | .086           | 1.084                |
| 17         | 1.750        | 1.1875                                  | 1.438              | M32X1-6g0.100R           | 1.625   | 1.259           | M25X1-6g0.100R           | .086           | 1.208                |
| 19         | 1.937        | 1.2500                                  | 1.562              | M35X1-6g0.100R           | 1.812   | 1.384           | M28X1-6g0.100R           | .118           | 1.333                |
| 21         | 2.062        | 1.3750                                  | 1.688              | M38X1-6g0.100R           | 1.938   | 1.507           | M31X1-6g0.100R           | .118           | 1.459                |
| 23         | 2.188        | 1.5000                                  | 1.812              | M41X1-6g0.100R           | 2.062   | 1.634           | M34X1-6g0.100R           | .118           | 1.575                |
| 25         | 2.312        | 1.6250                                  | 2.000              | M44X1-6g0.100R           | 2.188   | 1.759           | M37X1-6g0.100R           | .118           | 1.709                |

All dimensions for reference only.

# FCTV – MIL-DTL-38999, Series III Composite Box Mount Receptacle

(Printed Circuit Board Mount)



**PART #** To complete, see how to order pages 288-289.

| Filter Connector Designator | Connector Filter Type | Shell Finish | Shell Style | Shell Size & Insert Arrg | Type of Contact/ Keyway Position |
|-----------------------------|-----------------------|--------------|-------------|--------------------------|----------------------------------|
| 21                          | 78                    | X            | 2           | XX-XX                    | X                                |

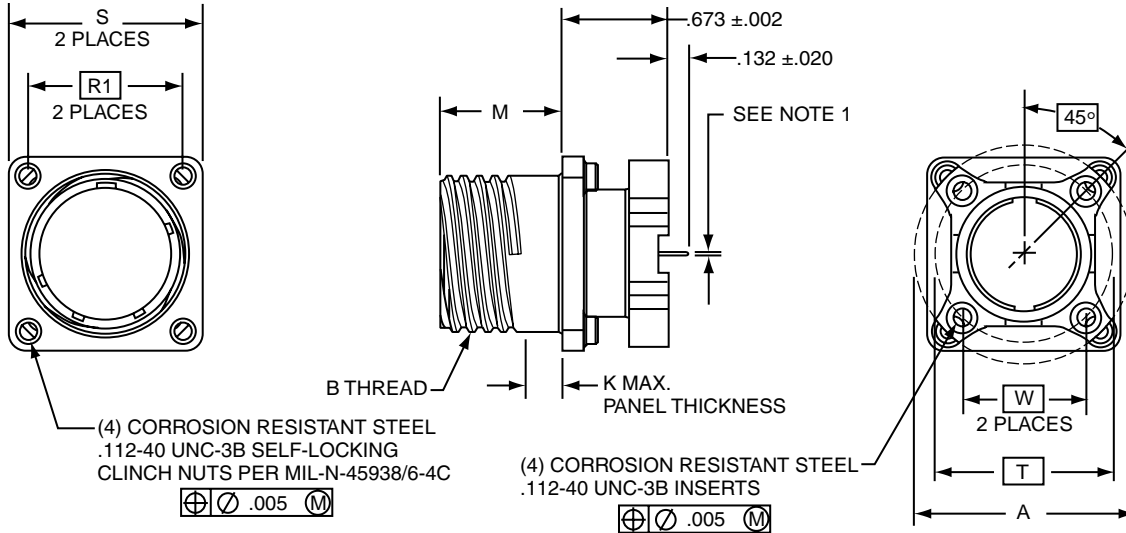

**21-78X2**

1. Standard tail for size 22 is .020 ±.001 dia.  
Standard tail for size 20 is .030 ±.001 dia.

| Shell Size | A Dia. ±.005 | B Thread Class 2A 0.1P-0.3L-TS (Plated) | M +.003 - .003 | K Max. Panel Thickness | R' TP | S +.011 - .010 | PCB Mounting Dimensions |       |
|------------|--------------|---|----------------|------------------------|-------|----------------|-------------------------|-------|
|            |              |   |                |                        |       |                | T Dia. TP               | W TP  |
| 9          | 1.016        | .6250                                   | .770           | .234                   | .719  | .938           | .752                    | .532  |
| 11         | 1.148        | .7500                                   | .770           | .234                   | .812  | 1.031          | .850                    | .601  |
| 13         | 1.250        | .8750                                   | .770           | .234                   | .906  | 1.125          | .994                    | .703  |
| 15         | 1.375        | 1.0000                                  | .770           | .234                   | .969  | 1.219          | 1.119                   | .791  |
| 17         | 1.500        | 1.1875                                  | .770           | .234                   | 1.062 | 1.312          | 1.237                   | .875  |
| 19         | 1.625        | 1.2500                                  | .770           | .234                   | 1.156 | 1.438          | 1.379                   | .975  |
| 21         | 1.750        | 1.3750                                  | .738           | .204                   | 1.250 | 1.562          | 1.489                   | 1.053 |
| 23         | 1.875        | 1.5000                                  | .738           | .204                   | 1.375 | 1.688          | 1.619                   | 1.145 |
| 25         | 2.000        | 1.6250                                  | .738           | .204                   | 1.500 | 1.812          | 1.744                   | 1.233 |

All dimensions for reference only.

III 38999  
II  
I  
SJT

26482  
Matrix 2

83723 III  
Matrix  
Pyle

5015  
Crimp Rear  
Release Matrix

26500 Pyle

Printed  
Circuit Board

EMI Filter  
Transient

Fiber Optics

High Speed  
Contacts

Options  
Others

### (Printed Circuit Board Mount)

38999  
SJT I II III

26482  
Matrix 2

83723 III  
Matrix Pyle

5015  
Crimp Rear Release Matrix

26500 Pyle

Printed  
Circuit Board

EMI Filter  
Transient

Fiber Optics

High Speed  
Contacts

Options  
Others

**PART #** To complete, see how to order pages 288-289.

|                             |                       |              |             |                          |                                 |
|-----------------------------|-----------------------|--------------|-------------|--------------------------|---------------------------------|
| Filter Connector Designator | Connector Filter Type | Shell Finish | Shell Style | Shell Size & Insert Arrg | Type of Contact/Keyway Position |
| 21                          | 78                    | X            | 7           | XX-XX                    | X                               |

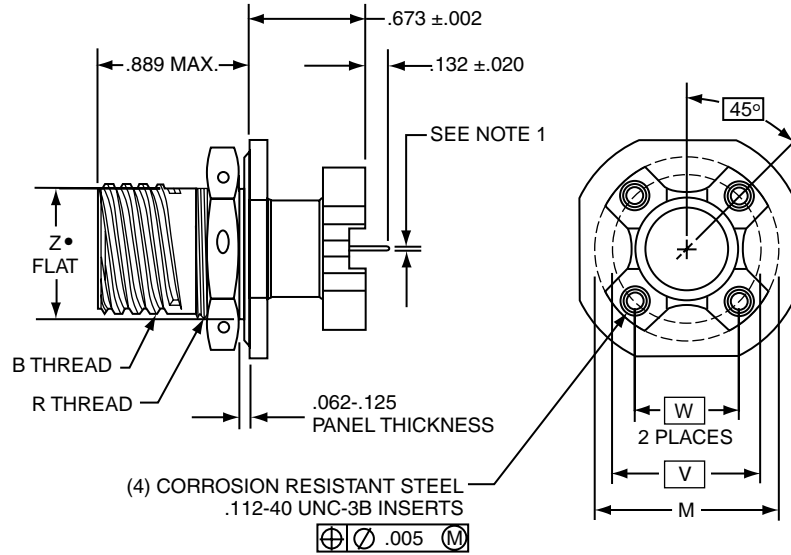
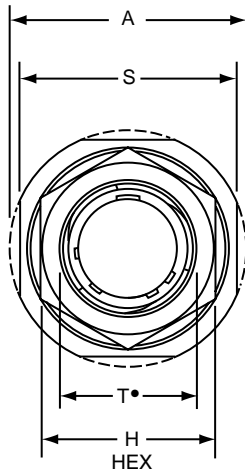

- 1. Standard tail for size 22 is .020±.001  
Standard tail for size 20 is .030±.001

- "D" shaped mounting hole dimensions

| Shell Size | A Dia. ±.005 | B Thread Class 2A 0.1P-0.3L-TS (Plated) | H Hex +.017 -0.016 | M Dia. ±.005 | R Thread Metric (Plated) | S +.011 -0.010 | T • Dia. +.010 -0.000 | PCB Mounting Dimensions |           | Z • Flat +.000 -0.010 |
|------------|--------------|---|--------------------|--------------|--------------------------|----------------|-----------------------|-------------------------|-----------|-----------------------|
|            |              |   |                    |              |                          |                |                       | W TP                    | V Dia. TP |                       |
| 9          | 1.188        | .6250                                   | .875               | 1.016        | M17X1-6g0.100R           | 1.062          | .697                  | .532                    | .752      | .669                  |
| 11         | 1.375        | .7500                                   | 1.000              | 1.148        | M20X1-6g0.100R           | 1.250          | .822                  | .601                    | .850      | .769                  |
| 13         | 1.500        | .8750                                   | 1.188              | 1.250        | M25X1-6g0.100R           | 1.375          | 1.007                 | .703                    | .994      | .955                  |
| 15         | 1.625        | 1.0000                                  | 1.312              | 1.375        | M28X1-6g0.100R           | 1.500          | 1.134                 | .791                    | 1.119     | 1.084                 |
| 17         | 1.750        | 1.1875                                  | 1.438              | 1.500        | M32X1-6g0.100R           | 1.625          | 1.259                 | .875                    | 1.237     | 1.208                 |
| 19         | 1.937        | 1.2500                                  | 1.562              | 1.625        | M35X1-6g0.100R           | 1.812          | 1.384                 | .975                    | 1.379     | 1.333                 |
| 21         | 2.062        | 1.3750                                  | 1.688              | 1.750        | M38X1-6g0.100R           | 1.937          | 1.507                 | 1.053                   | 1.489     | 1.459                 |
| 23         | 2.188        | 1.5000                                  | 1.812              | 1.875        | M41X1-6g0.100R           | 2.062          | 1.634                 | 1.145                   | 1.619     | 1.575                 |
| 25         | 2.312        | 1.6250                                  | 2.000              | 2.000        | M44X1-6g0.100R           | 2.188          | 1.759                 | 1.233                   | 1.744     | 1.709                 |

All dimensions for reference only.

# FTV – MIL-DTL-38999, Series III Wall Mounting Receptacle - Aluminum



(Mil-Spec Length)

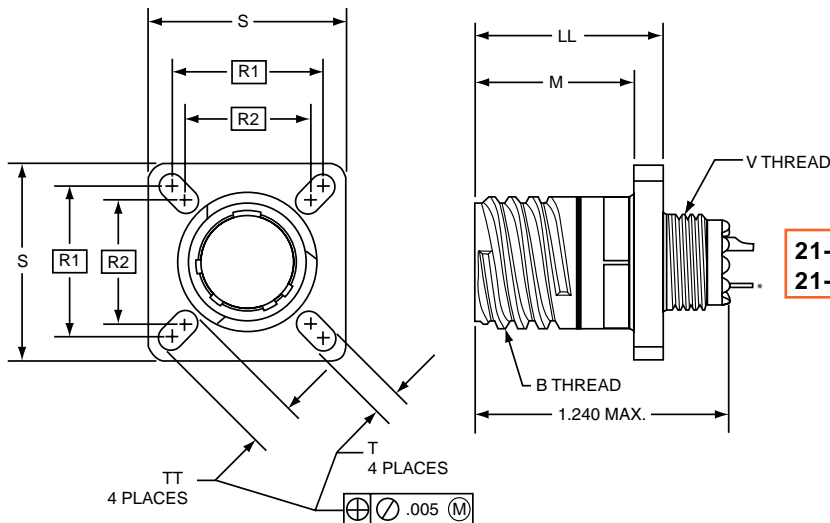

| PART #                          | 21    | 21    |
|---------------------------------|-------|-------|
| Filter Connector Designator     | 21    | 21    |
| Connector Filter Type           | 77    | 79    |
| Shell Finish                    | X     | X     |
| Shell Style                     | 0     | 0     |
| Shell Size & Insert Arrg        | XX-XX | XX-XX |
| Type of Contact/Keyway Position | X     | X     |

\* Printed Circuit Tail available. Consult Amphenol Aerospace, Sidney, NY for Part Number.

| Shell Size | B Thread Class 2A 0.1P-0.3L-TS (Plated) | M +.000 - .005 | LL +.006 - .000 | R' TP | R <sup>2</sup> TP | S Max | T +.008 - .006 | V Thread Metric (Plated) | TT +.008 - .006 |
|------------|---|----------------|-----------------|-------|-------------------|-------|----------------|--------------------------|-----------------|
| 9          | .6250                                   | .820           | .905            | .719  | .594              | .948  | .128           | M12X1-6g0.100R           | .216            |
| 11         | .7500                                   | .820           | .905            | .812  | .719              | 1.043 | .128           | M15X1-6g0.100R           | .194            |
| 13         | .8750                                   | .820           | .905            | .906  | .812              | 1.137 | .128           | M18X1-6g0.100R           | .194            |
| 15         | 1.0000                                  | .820           | .905            | .969  | .906              | 1.232 | .128           | M22X1-6g0.100R           | .173            |
| 17         | 1.1875                                  | .820           | .905            | 1.062 | .969              | 1.323 | .128           | M25X1-6g0.100R           | .194            |
| 19         | 1.2500                                  | .820           | .905            | 1.156 | 1.062             | 1.449 | .128           | M28X1-6g0.100R           | .194            |
| 21         | 1.3750                                  | .790           | .905            | 1.250 | 1.156             | 1.575 | .128           | M31X1-6g0.100R           | .194            |
| 23         | 1.5000                                  | .790           | .905            | 1.375 | 1.250             | 1.701 | .154           | M34X1-6g0.100R           | .242            |
| 25         | 1.6250                                  | .790           | .905            | 1.500 | 1.375             | 1.823 | .154           | M37X1-6g0.100R           | .242            |

All dimensions for reference only.

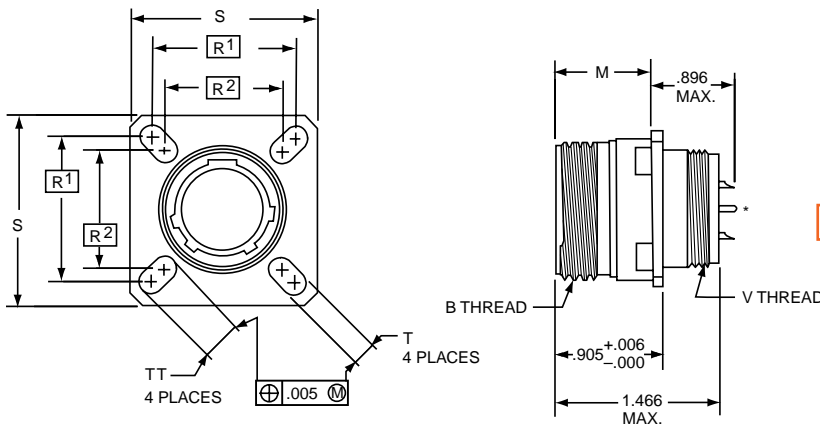

(Extended length shell\*\*)

| PART #                          | 21    |
|---------------------------------|-------|
| Filter Connector Designator     | 21    |
| Connector Filter Type           | 52    |
| Shell Finish                    | X     |
| Shell Style                     | 0     |
| Shell Size & Insert Arrg        | XX-XX |
| Type of Contact/Keyway Position | X     |

\* Printed Circuit Tail available. Consult Amphenol Aerospace, Sidney, NY for Part Number.

| Shell Size | B Thread Class 2A 0.1P-0.3L-TS (Plated) | M +.000 - .005 | R' TP | R <sup>2</sup> TP | S ±.010 | T +.008 - .006 | V Thread Metric (Plated) | TT +.008 - .006 |
|------------|---|----------------|-------|-------------------|---------|----------------|--------------------------|-----------------|
| 9          | .6250                                   | .820           | .719  | .594              | .938    | .128           | M12X1-6g0.100R           | .216            |
| 11         | .7500                                   | .820           | .812  | .719              | 1.031   | .128           | M15X1-6g0.100R           | .194            |
| 13         | .8750                                   | .820           | .906  | .812              | 1.125   | .128           | M18X1-6g0.100R           | .194            |
| 15         | 1.0000                                  | .820           | .969  | .906              | 1.219   | .128           | M22X1-6g0.100R           | .173            |
| 17         | 1.1875                                  | .820           | 1.062 | .969              | 1.312   | .128           | M25X1-6g0.100R           | .194            |
| 19         | 1.2500                                  | .820           | 1.156 | 1.062             | 1.438   | .128           | M28X1-6g0.100R           | .194            |
| 21         | 1.3750                                  | .790           | 1.250 | 1.156             | 1.562   | .128           | M31X1-6g0.100R           | .194            |
| 23         | 1.5000                                  | .790           | 1.375 | 1.250             | 1.688   | .154           | M34X1-6g0.100R           | .242            |
| 25         | 1.6250                                  | .790           | 1.500 | 1.375             | 1.812   | .154           | M37X1-6g0.100R           | .242            |

\*\*Extended length accommodate higher voltage and/or higher capacitance applications

Plug movement required to clear FTV receptacles: .625 min.

- III 38999
- II 26482 Matrix 2
- I 83723 III Matrix
- SJT Pyle
- 5015 Crimp Rear Release Matrix
- 26500 Pyle
- Printed Circuit Board
- EMI Filter Transient
- Fiber Optics
- High Speed Contacts
- Options Others

38999  
SJT I II III

26482  
Matrix 2

83723 III  
Matrix Pyle

5015  
Crimp Rear  
Release Matrix

26500 Pyle

Printed  
Circuit Board

EMI Filter  
Transient

Fiber Optics

High Speed  
Contacts

Options  
Others

**PART #** To complete, see how to order pages 288-289.

|                             |                       |              |             |                          |                                  |
|-----------------------------|-----------------------|--------------|-------------|--------------------------|----------------------------------|
| Filter Connector Designator | Connector Filter Type | Shell Finish | Shell Style | Shell Size & Insert Arrg | Type of Contact/ Keyway Position |
| 21                          | 50                    | X            | 0           | XX-XX                    | X                                |

**UTS (Crimp) Contact SAE AS39029/57**

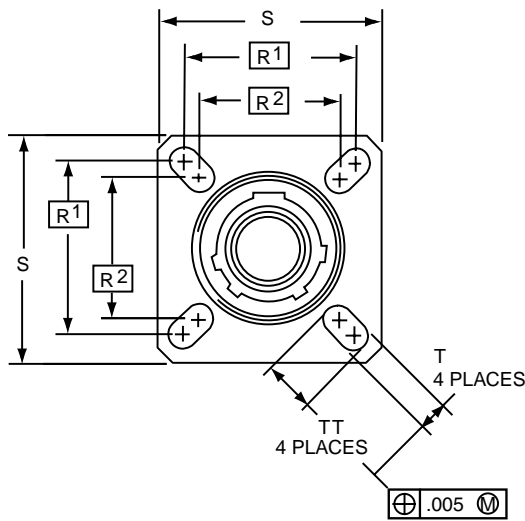

**21-50X0**  
UTS (Crimp) Contact  
SAE AS39029/57

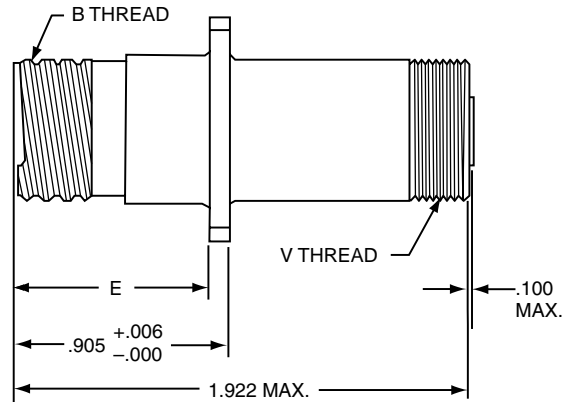

| Shell Size | BThread Class 2A 0.1P-0.3L-TS (Plated) | E +.000 - .005 | R <sup>1</sup> TP | R <sup>2</sup> TP | S ±.010 | T +.008 - .006 | V Thread Metric (Plated) | TT +.008 - .006 |
|------------|--|----------------|-------------------|-------------------|---------|----------------|--------------------------|-----------------|
| 9          | .6250                                  | .820           | .719              | .594              | .938    | .128           | M15X1-6g0.100R           | .216            |
| 11         | .7500                                  | .820           | .812              | .719              | 1.031   | .128           | M18X1-6g0.100R           | .194            |
| 13         | .8750                                  | .820           | .906              | .812              | 1.125   | .128           | M22X1-6g0.100R           | .194            |
| 15         | 1.0000                                 | .820           | .969              | .906              | 1.219   | .128           | M25X1-6g0.100R           | .173            |
| 17         | 1.1875                                 | .820           | 1.062             | .969              | 1.312   | .128           | M28X1-6g0.100R           | .194            |
| 19         | 1.2500                                 | .820           | 1.156             | 1.062             | 1.438   | .128           | M31X1-6g0.100R           | .194            |
| 21         | 1.3750                                 | .790           | 1.250             | 1.156             | 1.562   | .128           | M34X1-6g0.100R           | .194            |
| 23         | 1.5000                                 | .790           | 1.375             | 1.250             | 1.688   | .154           | M37X1-6g0.100R           | .242            |
| 25         | 1.6250                                 | .790           | 1.500             | 1.375             | 1.812   | .154           | M41X1-6g0.100R           | .242            |

All dimensions for reference only.



# FTV – MIL-DTL-38999, Series III Jam Nut Receptacle - Aluminum

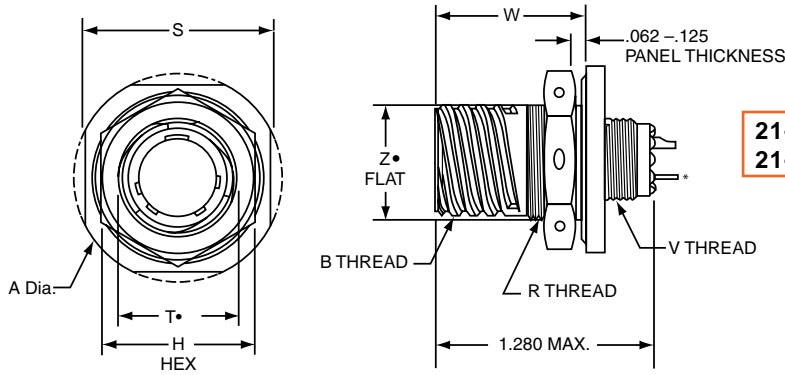

**21-77X7**  
**21-79X7**

| PART #                          | 21    | 21    |
|---------------------------------|-------|-------|
| Filter Connector Designator     | 21    | 21    |
| Connector Filter Type           | 77    | 79    |
| Shell Finish                    | X     | X     |
| Shell Style                     | 7     | 7     |
| Shell Size & Insert Arrg        | XX-XX | XX-XX |
| Type of Contact/Keyway Position | X     | X     |

\* Printed Circuit Tail available. Consult Amphenol Aerospace factory for P/N. • "D" shaped mounting hole dimensions

| Shell Size | A Dia* Max | B Thread Class 2A 0.1P-0.3L-TS (Plated) | H Hex +.017 -.016 | R Thread Metric (Plated) | S ±.010 | T* Dia +.010 -.000 | V Thread Metric (Plated) | W +.011 -.010 | Z* Flat +.000 -.010 |
|------------|------------|---|-------------------|--------------------------|---------|--------------------|--------------------------|---------------|---------------------|
| 9          | 1.199      | .6250                                   | .875              | M17X1-6g0.100R           | 1.062   | .697               | M12X1-6g0.100R           | .871          | .669                |
| 11         | 1.386      | .7500                                   | 1.000             | M20X1-6g0.100R           | 1.250   | .822               | M15X1-6g0.100R           | .871          | .769                |
| 13         | 1.511      | .8750                                   | 1.188             | M25X1-6g0.100R           | 1.375   | 1.007              | M18X1-6g0.100R           | .878          | .955                |
| 15         | 1.636      | 1.0000                                  | 1.312             | M28X1-6g0.100R           | 1.500   | 1.134              | M22X1-6g0.100R           | .878          | 1.084               |
| 17         | 1.761      | 1.1875                                  | 1.438             | M32X1-6g0.100R           | 1.625   | 1.259              | M25X1-6g0.100R           | .878          | 1.208               |
| 19         | 1.949      | 1.2500                                  | 1.562             | M35X1-6g0.100R           | 1.812   | 1.384              | M28X1-6g0.100R           | .878          | 1.333               |
| 21         | 2.073      | 1.3750                                  | 1.688             | M38X1-6g0.100R           | 1.938   | 1.507              | M31X1-6g0.100R           | .878          | 1.459               |
| 23         | 2.199      | 1.5000                                  | 1.812             | M41X1-6g0.100R           | 2.062   | 1.634              | M34X1-6g0.100R           | .878          | 1.575               |
| 25         | 2.323      | 1.6250                                  | 2.000             | M44X1-6g0.100R           | 2.188   | 1.759              | M37X1-6g0.100R           | .878          | 1.709               |

(Extended length shell\*\*)

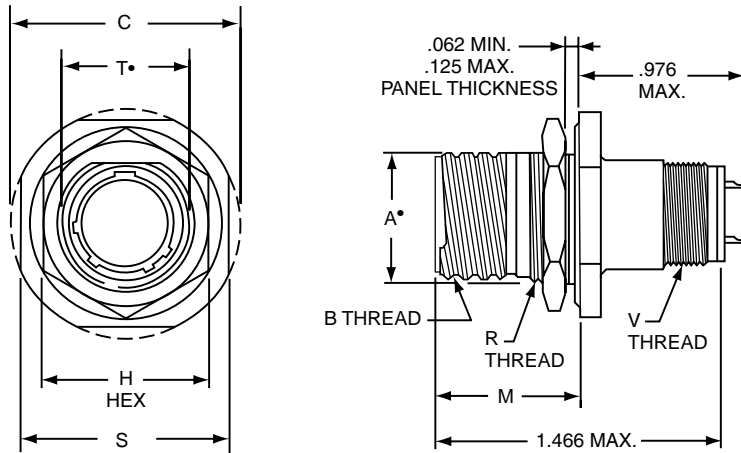

**21-52X7**

| PART #                          | 21    |
|---------------------------------|-------|
| Filter Connector Designator     | 21    |
| Connector Filter Type           | 52    |
| Shell Finish                    | X     |
| Shell Style                     | 7     |
| Shell Size & Insert Arrg        | XX-XX |
| Type of Contact/Keyway Position | X     |

• "D" shaped mounting hole dimensions

| Shell Size | A* +.000 -.010 | B Thread Class 2A 0.1P-0.3L-TS (Plated) | C Max | H Hex +.017 -.016 | M +.011 -.010 | R Thread (Plated) | S +.011 -.010 | T* +.010 -.000 | V Thread Metric (Plated) |
|------------|----------------|---|-------|-------------------|---------------|-------------------|---------------|----------------|--------------------------|
| 9          | .669           | .6250                                   | 1.199 | .875              | .871          | M17X1-6g0.100R    | 1.062         | .697           | M12X1-6g0.100R           |
| 11         | .769           | .7500                                   | 1.386 | 1.000             | .871          | M20X1-6g0.100R    | 1.250         | .822           | M15X1-6g0.100R           |
| 13         | .955           | .8750                                   | 1.511 | 1.188             | .878          | M25X1-6g0.100R    | 1.375         | 1.007          | M18X1-6g0.100R           |
| 15         | 1.084          | 1.0000                                  | 1.636 | 1.312             | .878          | M28X1-6g0.100R    | 1.500         | 1.134          | M22X1-6g0.100R           |
| 17         | 1.208          | 1.1875                                  | 1.761 | 1.438             | .878          | M32X1-6g0.100R    | 1.625         | 1.259          | M25X1-6g0.100R           |
| 19         | 1.333          | 1.2500                                  | 1.949 | 1.562             | .878          | M35X1-6g0.100R    | 1.812         | 1.384          | M28X1-6g0.100R           |
| 21         | 1.459          | 1.3750                                  | 2.073 | 1.688             | .878          | M38X1-6g0.100R    | 1.938         | 1.507          | M31X1-6g0.100R           |
| 23         | 1.575          | 1.5000                                  | 2.199 | 1.812             | .878          | M41X1-6g0.100R    | 2.062         | 1.634          | M34X1-6g0.100R           |
| 25         | 1.709          | 1.6250                                  | 2.323 | 2.000             | .878          | M44X1-6g0.100R    | 2.188         | 1.759          | M37X1-6g0.100R           |

\*\*Extended length to accommodate higher voltage and/or higher capacitance applications

Plug movement required to clear FTV receptacles: .625 min.

All dimensions for reference only.

III 38999 II I SJT

Matrix 2 26482

Matrix Pyle 83723 III

Release Matrix 5015 Crimp Rear

26500 Pyle

Printed Circuit Board

EM I Filter Transient

Fiber Optics

High Speed Contacts

Options Others

38999  
SJT I II III

26482  
Matrix 2

83723 III  
Matrix Pyle

5015  
Crimp Rear  
Release Matrix

26500 Pyle

Printed  
Circuit Board

EMI Filter  
Transient

Fiber Optics

High Speed  
Contacts

Options  
Others

**PART # To complete, see how to order pages 288-289.**

|                             |                       |              |             |                          |                                  |
|-----------------------------|-----------------------|--------------|-------------|--------------------------|----------------------------------|
| Filter Connector Designator | Connector Filter Type | Shell Finish | Shell Style | Shell Size & Insert Arrg | Type of Contact/ Keyway Position |
| 21                          | 50                    | X            | 7           | XX-XX                    | X                                |

**UTS (Crimp) Contact SAE AS39029/57**

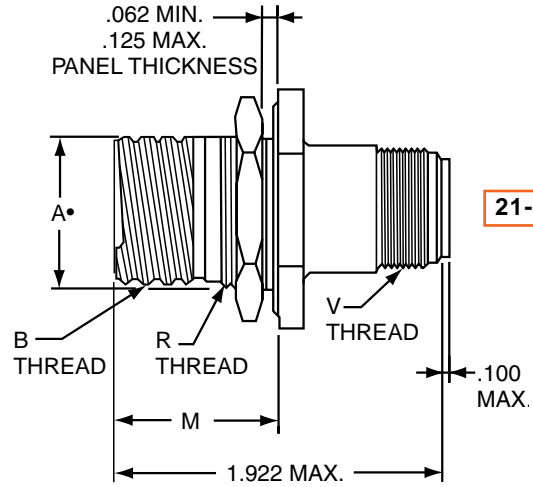
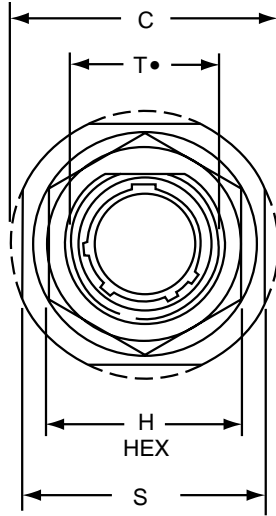

**21-50X7**

• "D" shaped mounting hole dimensions

| Shell Size | A*<br>+.000<br>-.010 | B Thread<br>Class 2A<br>0.1P-0.3L-TS<br>(Plated) | C<br>Max | H<br>Hex<br>+.017<br>-.016 | M<br>±.005 | R<br>Thread<br>(Plated) | S<br>+.011<br>-.010 | T*<br>+.010<br>-.000 | V<br>Thread<br>Metric<br>(Plated) |
|------------|----------------------|--|----------|----------------------------|------------|-------------------------|---------------------|----------------------|-----------------------------------|
| 9          | .669                 | .6250  | 1.199    | .875                       | .871       | M17X1-6g0.100R          | 1.062               | .697                 | M15X1-6g0.100R                    |
| 11         | .769                 | .7500  | 1.386    | 1.000                      | .871       | M20X1-6g0.100R          | 1.250               | .822                 | M18X1-6g0.100R                    |
| 13         | .955                 | .8750  | 1.511    | 1.188                      | .878       | M25X1-6g0.100R          | 1.375               | 1.007                | M22X1-6g0.100R                    |
| 15         | 1.084                | 1.0000   | 1.636    | 1.312                      | .878       | M28X1-6g0.100R          | 1.500               | 1.134                | M25X1-6g0.100R                    |
| 17         | 1.208                | 1.1875   | 1.761    | 1.438                      | .878       | M32X1-6g0.100R          | 1.625               | 1.259                | M28X1-6g0.100R                    |
| 19         | 1.333                | 1.2500   | 1.949    | 1.562                      | .878       | M35X1-6g0.100R          | 1.812               | 1.384                | M31X1-6g0.100R                    |
| 21         | 1.459                | 1.3750   | 2.073    | 1.688                      | .878       | M38X1-6g0.100R          | 1.938               | 1.507                | M34X1-6g0.100R                    |
| 23         | 1.575                | 1.5000   | 2.199    | 1.812                      | .878       | M41X1-6g0.100R          | 2.062               | 1.634                | M37X1-6g0.100R                    |
| 25         | 1.709                | 1.6250   | 2.323    | 2.000                      | .878       | M44X1-6g0.100R          | 2.188               | 1.759                | M41X1-6g0.100R                    |

All dimensions for reference only.

Plug movement required to clear FTV receptacles: .625 min.

**PART #** To complete, see how to order pages 288-289.

| Filter Connector Designator | Connector Filter Type | Shell Finish | Shell Style | Shell Size & Insert Arrg | Type of Contact/ Keyway Position |
|-----------------------------|-----------------------|--------------|-------------|--------------------------|----------------------------------|
| 21                          | 80                    | X            | 2           | XX-XX                    | X                                |

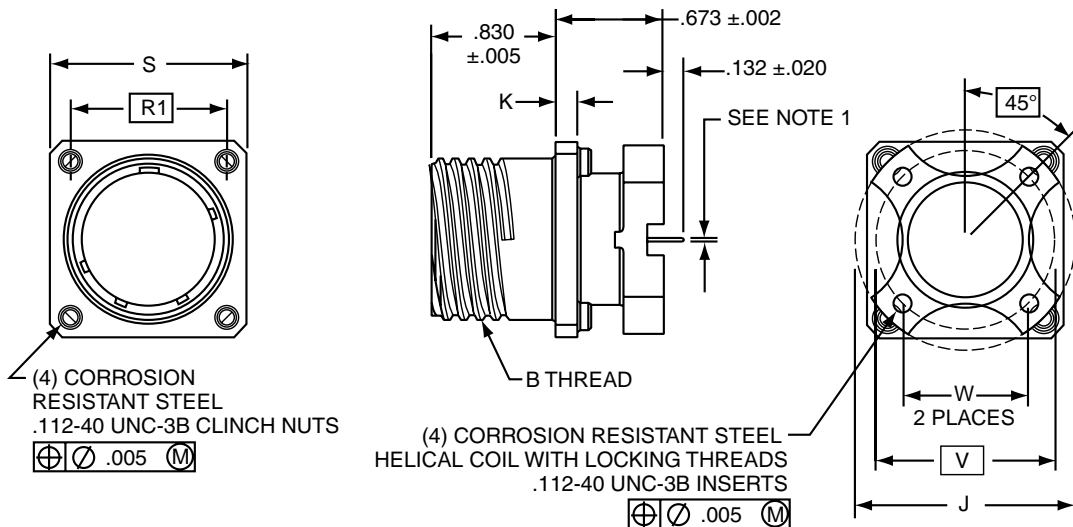

**21-80X2**

Note 1. Standard tail for size 22 is .020 ±.001.  
Standard tail for size 20 is .030 ±.001.

| Shell Size | BThread Class 2A 0.1P-0.3L-TS (Plated) | J Dia. ±.005 | K ±.005 | R' TP | S ±.010 | PCB Mounting Dimensions |           |
|------------|--|--------------|---------|-------|---------|-------------------------|-----------|
|            |  |              |         |       |         | W TP                    | V Dia. TP |
| 9          | .6250                                  | 1.016        | .085    | .719  | .938    | .532                    | .752      |
| 11         | .7500                                  | 1.062        | .085    | .812  | 1.031   | .601                    | .850      |
| 13         | .8750                                  | 1.250        | .085    | .906  | 1.125   | .703                    | .994      |
| 15         | 1.0000                                 | 1.375        | .085    | .969  | 1.219   | .791                    | 1.119     |
| 17         | 1.1875                                 | 1.500        | .085    | 1.062 | 1.312   | .875                    | 1.237     |
| 19         | 1.2500                                 | 1.625        | .085    | 1.156 | 1.438   | .975                    | 1.379     |
| 21         | 1.3750                                 | 1.750        | .115    | 1.250 | 1.562   | 1.053                   | 1.489     |
| 23         | 1.5000                                 | 1.875        | .115    | 1.375 | 1.688   | 1.145                   | 1.619     |
| 25         | 1.6250                                 | 2.000        | .115    | 1.500 | 1.812   | 1.233                   | 1.744     |

All dimensions for reference only.

- III 38999
- II
- I
- SJT
- 26482 Matrix 2
- 83723 III Matrix Pyle
- 5015 Crimp Rear Release Matrix
- 26500 Pyle
- Printed Circuit Board
- EMI Filter Transient
- Fiber Optics
- High Speed Contacts
- Options Others



The Amphenol® FJT Series space and weight saving design, coupled with a filter, gives high reliability.

- Intermateable with MIL-DTL-38999/27599 Series II connectors (see section Series II JT)
- Quick positive coupling – 3 point bayonet locking
- Error-proof alternate positioning of shell keyways
- Higher reliability and greater durability with permanently encapsulated contacts
- Environmental resistant
- Aluminum shells with several finish options



FJT

FJT Master Key/Keyway Rotation

| Shell Size | AB Angle of Rotation (Degrees) |    |    |     |     |
|------------|--------------------------------|----|----|-----|-----|
|            | Normal                         | A  | B  | C   | D   |
| 8          | 100                            | 82 | –  | –   | 118 |
| 10         | 100                            | 86 | 72 | 128 | 114 |
| 12         | 100                            | 80 | 68 | 132 | 120 |
| 14         | 100                            | 79 | 66 | 134 | 121 |
| 16         | 100                            | 82 | 70 | 130 | 118 |
| 18         | 100                            | 82 | 70 | 130 | 118 |
| 20         | 100                            | 82 | 70 | 130 | 118 |
| 22         | 100                            | 85 | 74 | 126 | 115 |
| 24         | 100                            | 85 | 74 | 126 | 115 |

A plug with a given rotation letter will mate with a receptacle with the same rotation letter. The AB angle for a given connector is the same whether it contains pins or sockets. Inserts are not rotated in conjunction with the master key/keyway.

AB angles shown are viewed from the front face of the connector. A receptacle is shown at right. The angles for the plug are exactly the same, except the direction of rotation is opposite of that shown for the receptacle.

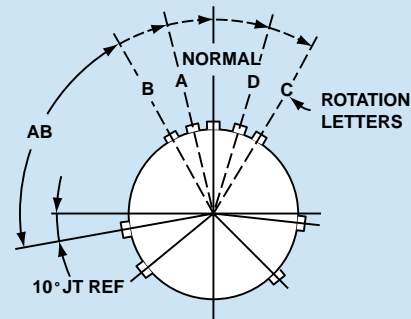

RELATIVE POSSIBLE POSITION OF ROTATED MASTER KEYWAY (front face of receptacle shown)

38999  
III  
II  
I  
SJT

26482  
Matrix 2

83723 III  
Matrix  
Pyle

5015  
Crimp Rear  
Release Matrix

26500 Pyle

Printed  
Circuit Board

EMI Filter  
Transient

Fiber Optics

High Speed  
Contacts

Options  
Others

38999  
SJT I II III

26482  
Matrix 2

83723 III  
Matrix Pyle

5015  
Crimp Rear Release Matrix

26500 Pyle

Printed  
Circuit Board

EMI Filter  
Transient

Fiber Optics

High Speed  
Contacts

Options  
Others

### PART #

To complete, see how to order pages 288-289.

| Filter Connector Designator | Connector Filter Type | Shell Finish | Shell Style | Shell Size & Insert Arrg | Type of Contact/ Keyway Position |
|-----------------------------|-----------------------|--------------|-------------|--------------------------|----------------------------------|
| 21                          | 24                    | X            | 0           | XX-XX                    | X                                |
| 21                          | 32                    | X            | 0           | XX-XX                    | X                                |
| 21                          | 37                    | X            | 0           | XX-XX                    | X                                |

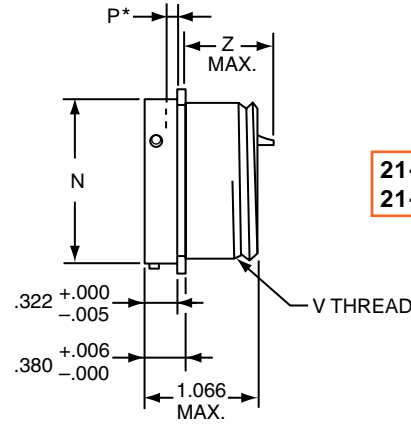
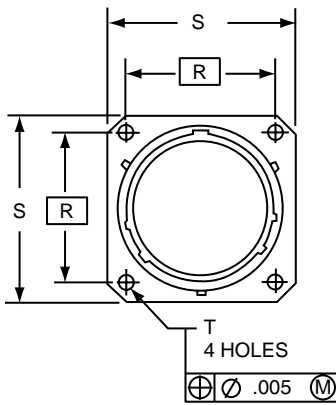

21-24X0 (MS27334)  
21-32X0 (MS27334)

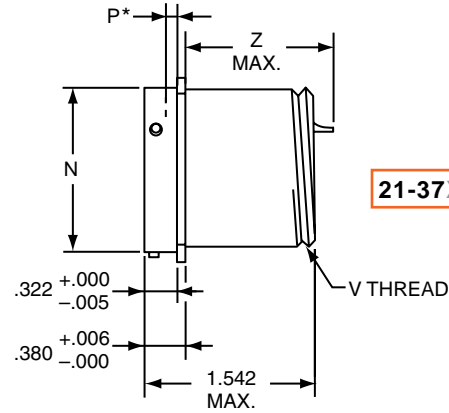

21-37X0 (MS27334)

Plug movement required to clear FJT receptacles: .281 min.

\* Acceptable panel thickness for back panel mounting a standard receptacle.

| Shell Size | N Dia<br>+.001<br>-.005 | P*<br>Max. | R (TP) | S<br>+.011<br>-.010 | T<br>Dia.<br>±.005 | V<br>Thread<br>UNEF-2A<br>(Plated) | SHORT SHELL<br>VHF/UHF/MF Filters |   |                              | LONG SHELL<br>HF Filters     |   |
|------------|-------------------------|------------|--------|---------------------|--------------------|------------------------------------|-----------------------------------|---|------------------------------|------------------------------|---|
|            |                         |            |        |                     |                    |                                    | Size 20<br>Contact<br>Z Max.      | Size 16 or<br>16 & 20<br>Contacts<br>Z Max. | Size 22<br>Contact<br>Z Max. | Size 20<br>Contact<br>Z Max. | Size 16 or<br>16 & 20<br>Contacts<br>Z Max. |
| 8          | .473                    | .022       | .594   | .812                | .120               | .4375-28                           | .937                              | .952  | .902                         | 1.300                        | 1.496                                       |
| 10         | .590                    | .027       | .719   | .938                | .120               | .5625-24                           | .937                              | .952  | .902                         | 1.300                        | 1.496                                       |
| 12         | .750                    | .027       | .812   | 1.031               | .120               | .6875-24                           | .937                              | .952  | .902                         | 1.300                        | 1.496                                       |
| 14         | .875                    | .027       | .906   | 1.125               | .120               | .8125-20                           | .937                              | .952  | .902                         | 1.300                        | 1.496                                       |
| 16         | 1.000                   | .027       | .969   | 1.219               | .120               | .9375-20                           | .937                              | .952  | .902                         | 1.300                        | 1.496                                       |
| 18         | 1.125                   | .027       | 1.062  | 1.312               | .120               | 1.0625-18                          | .937                              | .952  | .902                         | 1.300                        | 1.496                                       |
| 20         | 1.250                   | .054       | 1.156  | 1.438               | .120               | 1.1875-18                          | .937                              | .952  | .902                         | 1.300                        | 1.496                                       |
| 22         | 1.375                   | .054       | 1.250  | 1.562               | .120               | 1.3125-18                          | .937                              | .952  | .902                         | 1.300                        | 1.496                                       |
| 24         | 1.500                   | .054       | 1.375  | 1.688               | .147               | 1.4375-18                          | .937                              | .952  | .902                         | 1.300                        | 1.496                                       |

All dimensions for reference only.



# FJTP – MIL-DTL-38999, Series II

## Wall Mounting Receptacle - Aluminum

(Back Panel Mounting)

| PART #                                       | Filter    | Connector   | Shell  | Shell | Shell Size    | Type of Contact/ |
|--|-----------|-------------|--------|-------|---------------|------------------|
|  | Connector | Filter Type | Finish | Style | & Insert Arrg | Keyway Position  |
| To complete, see how to order pages 288-289. | 21        | 34          | X      | 0     | XX-XX         | X                |
|  | 21        | 39          | X      | 0     | XX-XX         | X                |
|  | 21        | 38          | X      | 0     | XX-XX         | X                |

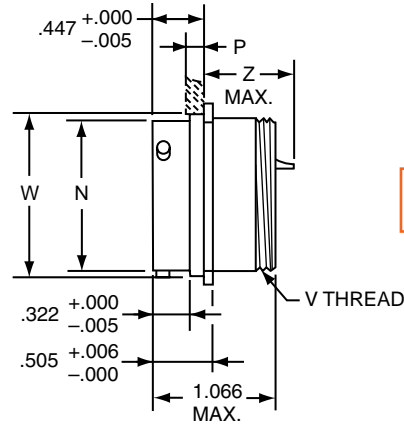
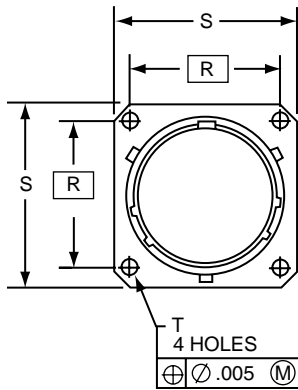

21-34X0 (MS27497)  
21-39X0 (MS27497)

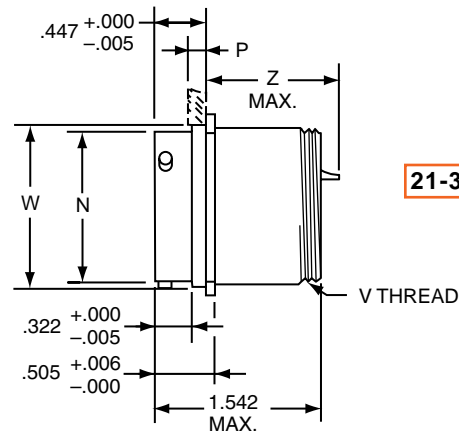

21-38X0 (MS27497)

Plug movement required to clear FJT receptacles: .281 min.

| Shell Size | N Dia<br>+.001<br>-.005 | P Max.<br>Panel<br>Thickness | R (TP) | S<br>+.011<br>-.010 | T<br>Dia.<br>±.005 | V<br>Thread<br>UNE-F-2A<br>(Plated) | W<br>Dia.<br>+.001<br>-.005 | SHORT SHELL<br>VHF/UHF/MF Filters           |                                       | LONG SHELL<br>HF Filters                    |                              |
|------------|-------------------------|------------------------------|--------|---------------------|--------------------|-------------------------------------|-----------------------------|---|---------------------------------------|---|------------------------------|
|            |                         |                              |        |                     |                    |                                     |                             | Size 16 or<br>16 & 20<br>Contacts<br>Z Max. | Size 20<br>or 22<br>Contact<br>Z Max. | Size 16 or<br>16 & 20<br>Contacts<br>Z Max. | Size 20<br>Contact<br>Z Max. |
| 8          | .473                    | .147                         | .594   | .812                | .120               | .4375-28                            | .516                        | .900  | .875                                  | 1.385                                       | 1.285                        |
| 10         | .590                    | .152                         | .719   | .938                | .120               | .5625-24                            | .633                        | .900  | .875                                  | 1.385                                       | 1.285                        |
| 12         | .750                    | .152                         | .812   | 1.031               | .120               | .6875-24                            | .802                        | .900  | .875                                  | 1.385                                       | 1.285                        |
| 14         | .875                    | .152                         | .906   | 1.125               | .120               | .8125-20                            | .927                        | .900  | .875                                  | 1.385                                       | 1.285                        |
| 16         | 1.000                   | .152                         | .969   | 1.219               | .120               | .9375-20                            | 1.052                       | .900  | .875                                  | 1.385                                       | 1.285                        |
| 18         | 1.125                   | .152                         | 1.062  | 1.312               | .120               | 1.0625-18                           | 1.177                       | .900  | .875                                  | 1.385                                       | 1.285                        |
| 20         | 1.250                   | .179                         | 1.156  | 1.438               | .120               | 1.1875-18                           | 1.302                       | .900  | .875                                  | 1.385                                       | 1.285                        |
| 22         | 1.375                   | .179                         | 1.250  | 1.562               | .120               | 1.3125-18                           | 1.427                       | .900  | .875                                  | 1.385                                       | 1.285                        |
| 24         | 1.500                   | .179                         | 1.375  | 1.688               | .147               | 1.4375-18                           | 1.552                       | .900  | .875                                  | 1.385                                       | 1.285                        |

All dimensions for reference only.

III 38999  
II I SJT

26482  
Matrix 2

83723 III  
Matrix Pyle

5015  
Crimp Rear  
Release Matrix

26500 Pyle

Printed  
Circuit Board

EMI Filter  
Transient

Fiber Optics

High Speed  
Contacts

Options  
Others

38999  
SJT I II III

26482  
Matrix 2

83723 III  
Matrix Pyle

5015  
Crimp Rear  
Release Matrix

26500 Pyle

Printed  
Circuit Board

EMI Filter  
Transient

Fiber Optics

High Speed  
Contacts

Options  
Others

**PART #**  
To complete, see how to order pages 288-289.

| Filter Connector Designator | Connectoe Filter Type | Shell Finish | Shell Style | Shell Size & Insert Arrg | Type of Contact/ Keyway Position |
|-----------------------------|-----------------------|--------------|-------------|--------------------------|----------------------------------|
| 21                          | 24                    | X            | 2           | XX-XX                    | X                                |
| 21                          | 32                    | X            | 2           | XX-XX                    | X                                |
| 21                          | 37                    | X            | 2           | XX-XX                    | X                                |

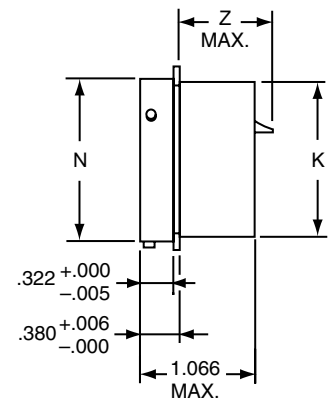
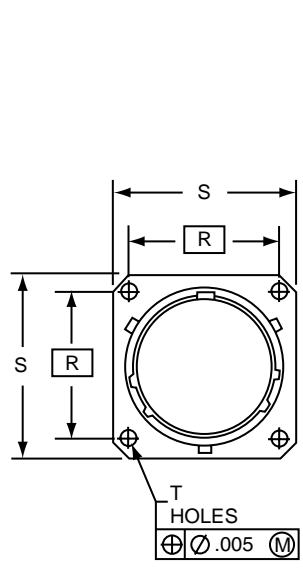

**21-24X2 (MS27335)**  
**21-32X2 (MS27335)**

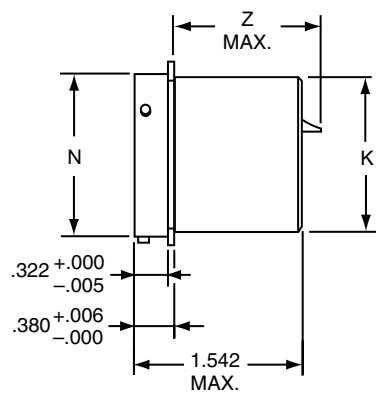

**21-37X2 (MS27335)**

Plug movement required to clear FJT receptacles: .281 min.

| Shell Size | K Dia. +.000 / -.007 | N Dia. +.001 / -.005 | R (TP) | S +.011 / -.010 | T Dia. ±.005 | SHORT SHELL<br>VHF/UHF/MF Filters |                                    |                        | LONG SHELL<br>HF Filters |                                    |
|------------|----------------------|----------------------|--------|-----------------|--------------|-----------------------------------|------------------------------------|------------------------|--------------------------|------------------------------------|
|            |                      |                      |        |                 |              | Size 20 Contact Z Max.            | Size 16 or 16 & 20 Contacts Z Max. | Size 22 Contact Z Max. | Size 20 Contact Z Max.   | Size 16 or 16 & 20 Contacts Z Max. |
| 8          | .438                 | .473                 | .594   | .812            | .120         | .937                              | .952                               | .902                   | 1.300                    | 1.496                              |
| 10         | .562                 | .590                 | .719   | .938            | .120         | .937                              | .952                               | .902                   | 1.300                    | 1.496                              |
| 12         | .688                 | .750                 | .812   | 1.031           | .120         | .937                              | .952                               | .902                   | 1.300                    | 1.496                              |
| 14         | .812                 | .875                 | .906   | 1.125           | .120         | .937                              | .952                               | .902                   | 1.300                    | 1.496                              |
| 16         | .938                 | 1.000                | .969   | 1.219           | .120         | .937                              | .952                               | .902                   | 1.300                    | 1.496                              |
| 18         | 1.062                | 1.125                | 1.062  | 1.312           | .120         | .937                              | .952                               | .902                   | 1.300                    | 1.496                              |
| 20         | 1.188                | 1.250                | 1.156  | 1.438           | .120         | .937                              | .952                               | .902                   | 1.300                    | 1.496                              |
| 22         | 1.312                | 1.375                | 1.250  | 1.562           | .120         | .937                              | .952                               | .902                   | 1.300                    | 1.496                              |
| 24         | 1.438                | 1.500                | 1.375  | 1.688           | .147         | .937                              | .952                               | .902                   | 1.300                    | 1.496                              |

All dimensions for reference only.

# FJTP – MIL-DTL-38999, Series II

## Box Mounting Receptacle - Aluminum

(Back Panel Mounting)



| PART #                                       | Filter Connector Designator | Connector Filter Type | Shell Finish | Shell Style | Shell Size & Insert Arrg | Type of Contact/ Keyway Position |
|--|-----------------------------|-----------------------|--------------|-------------|--------------------------|----------------------------------|
| To complete, see how to order pages 288-289. | 21                          | 34                    | X            | 2           | XX-XX                    | X                                |
|  | 21                          | 39                    | X            | 2           | XX-XX                    | X                                |
|  | 21                          | 38                    | X            | 2           | XX-XX                    | X                                |

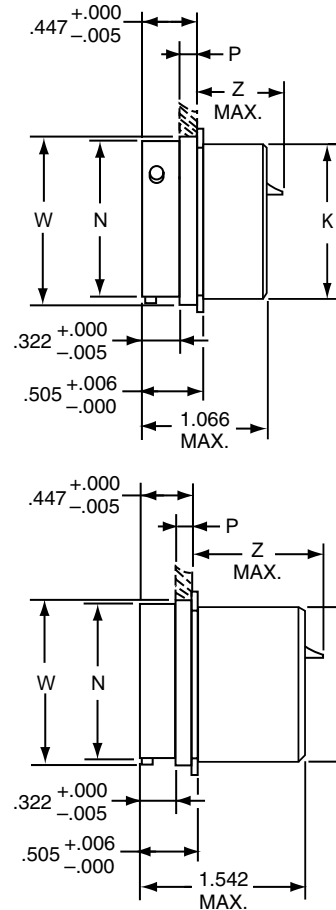
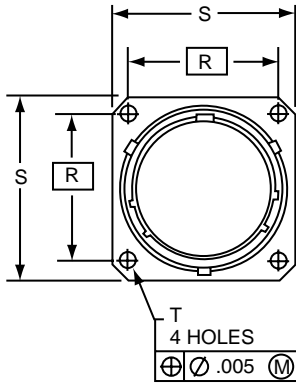

**21-34X2 (MS27508)**  
**21-39X2 (MS27508)**

**21-38X2 (MS27508)**

Plug movement required to clear FJT receptacles: .281 min.

| Shell Size | K Dia. +.000 - .007 | N Dia. +.001 - .005 | P Max. Panel Thickness | R (TP) | S +.011 - .010 | T Dia. ±.005 | W Dia. +.001 - .005 | SHORT SHELL VHF/UHF/MF Filters     |                              | LONG SHELL HF Filters              |                        |
|------------|---------------------|---------------------|------------------------|--------|----------------|--------------|---------------------|------------------------------------|------------------------------|------------------------------------|------------------------|
|            |                     |                     |                        |        |                |              |                     | Size 16 or 16 & 20 Contacts Z Max. | Size 20 or 22 Contact Z Max. | Size 16 or 16 & 20 Contacts Z Max. | Size 20 Contact Z Max. |
|            |                     |                     |                        |        |                |              |                     | 8                                  | .438                         | .473                               | .147                   |
| 10         | .562                | .590                | .152                   | .719   | .938           | .120         | .633                | .900                               | .875                         | 1.385                              | 1.285                  |
| 12         | .688                | .750                | .152                   | .812   | 1.031          | .120         | .802                | .900                               | .875                         | 1.385                              | 1.285                  |
| 14         | .812                | .875                | .152                   | .906   | 1.125          | .120         | .927                | .900                               | .875                         | 1.385                              | 1.285                  |
| 16         | .938                | 1.000               | .152                   | .969   | 1.219          | .120         | 1.052               | .900                               | .875                         | 1.385                              | 1.285                  |
| 18         | 1.062               | 1.125               | .152                   | 1.062  | 1.312          | .120         | 1.177               | .900                               | .875                         | 1.385                              | 1.285                  |
| 20         | 1.188               | 1.250               | .179                   | 1.156  | 1.438          | .120         | 1.302               | .900                               | .875                         | 1.385                              | 1.285                  |
| 22         | 1.312               | 1.375               | .179                   | 1.250  | 1.562          | .120         | 1.427               | .900                               | .875                         | 1.385                              | 1.285                  |
| 24         | 1.438               | 1.500               | .179                   | 1.375  | 1.688          | .147         | 1.552               | .900                               | .875                         | 1.385                              | 1.285                  |

All dimensions for reference only.

III 38999 II I SJT

26482 Matrix 2

83723 III Matrix Pyle

5015 Crimp Rear Release Matrix

26500 Pyle

Printed Circuit Board

EMI Filter Transient

Fiber Optics

High Speed Contacts

Options Others

38999  
SJT I II III

26482  
Matrix 2

83723 III  
Matrix Pyle

5015  
Crimp Rear  
Release Matrix

26500 Pyle

Printed  
Circuit Board

EMI Filter  
Transient

Fiber Optics

High Speed  
Contacts

Options  
Others

### PART #

To complete, see how to order pages 288-289.

| Filter Connector Designator | Connector Filter Type | Shell Finish | Shell Style | Shell Size & Insert Arrg | Type of Contact/ Keyway Position |
|-----------------------------|-----------------------|--------------|-------------|--------------------------|----------------------------------|
| 21                          | 24                    | X            | 7           | XX-XX                    | X                                |
| 21                          | 32                    | X            | 7           | XX-XX                    | X                                |
| 21                          | 37                    | X            | 7           | XX-XX                    | X                                |

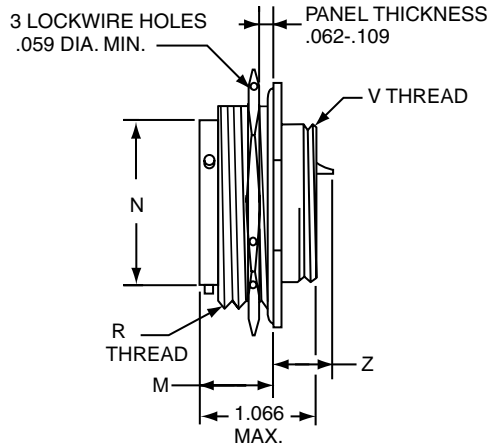
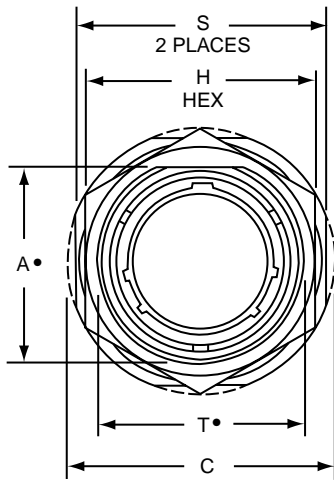

**21-24X7 (MS27337)**  
**21-32X7 (MS27337)**

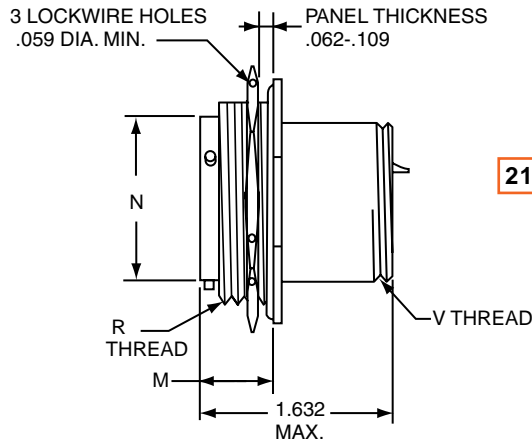

**21-37X7 (MS27337)**

• "D" shaped mounting hole dimensions  
Plug movement required to clear FJT receptacles: .281 min.

| Shell Size | A* Flat<br>+.000<br>-.010 | C Dia.<br>+.011<br>-.010 | H Hex<br>+.017<br>-.016 | M<br>±.005 | N Dia<br>+.001<br>-.005 | R Thread<br>(Plated)<br>Class -2A | S<br>±.010 | T* Dia.<br>+.010<br>-.000 | V Thread<br>UNE-F-2A<br>(Plated) | SHORT SHELL<br>VHF/UHF/MF Filters           |                              |                              | LONG SHELL<br>HF Filters                    |                              |
|------------|---------------------------|--------------------------|-------------------------|------------|-------------------------|-----------------------------------|------------|---------------------------|----------------------------------|---|------------------------------|------------------------------|---|------------------------------|
|            |                           |                          |                         |            |                         |                                   |            |                           |                                  | Size 16 or<br>16 & 20<br>Contacts<br>Z Max. | Size 20<br>Contact<br>Z Max. | Size 22<br>Contact<br>Z Max. | Size 16 or<br>16 & 20<br>Contacts<br>Z Max. | Size 20<br>Contact<br>Z Max. |
| 8          | .830                      | 1.375                    | 1.062                   | .438       | .473                    | .8750-20UNEF                      | 1.250      | .884                      | .4375-28                         | .900  | .884                         | .849                         | 1.443                                       | 1.276                        |
| 10         | .955                      | 1.500                    | 1.188                   | .438       | .590                    | 1.0000-20UNEF                     | 1.375      | 1.007                     | .5625-24                         | .900  | .884                         | .849                         | 1.443                                       | 1.276                        |
| 12         | 1.084                     | 1.625                    | 1.312                   | .438       | .750                    | 1.1250-18UNEF                     | 1.500      | 1.134                     | .6875-24                         | .900  | .884                         | .849                         | 1.443                                       | 1.276                        |
| 14         | 1.208                     | 1.750                    | 1.438                   | .438       | .875                    | 1.2500-18UNEF                     | 1.625      | 1.259                     | .8125-20                         | .900  | .884                         | .849                         | 1.443                                       | 1.276                        |
| 16         | 1.333                     | 1.938                    | 1.562                   | .438       | 1.000                   | 1.3750-18UNEF                     | 1.781      | 1.384                     | .9375-20                         | .900  | .884                         | .849                         | 1.443                                       | 1.276                        |
| 18         | 1.459                     | 2.016                    | 1.688                   | .438       | 1.125                   | 1.5000-18UNEF                     | 1.890      | 1.507                     | 1.0625-18                        | .900  | .884                         | .849                         | 1.443                                       | 1.276                        |
| 20         | 1.576                     | 2.141                    | 1.812                   | .464       | 1.250                   | 1.6250-18UNEF                     | 2.016      | 1.634                     | 1.1875-18                        | .874  | .858                         | .823                         | 1.443                                       | 1.276                        |
| 22         | 1.701                     | 2.265                    | 2.000                   | .464       | 1.375                   | 1.7500-18UNS                      | 2.140      | 1.759                     | 1.3125-18                        | .874  | .858                         | .823                         | 1.417                                       | 1.250                        |
| 24         | 1.826                     | 2.390                    | 2.125                   | .464       | 1.500                   | 1.8750-16UN                       | 2.265      | 1.884                     | 1.4375-18                        | .874  | .858                         | .823                         | 1.417                                       | 1.250                        |

All dimensions for reference only.

# FJTP – MIL-DTL-38999, Series II

## Jam Nut Receptacle - Aluminum

(Minimum Penetration)

**PART #**  
To complete, see how to order pages 288-289.

| Filter Connector Designator | Connector Filter Type | Shell Finish | Shell Style | Shell Size & Insert Arrg | Type of Contact/ Keyway Position |
|-----------------------------|-----------------------|--------------|-------------|--------------------------|----------------------------------|
| 21                          | 24                    | X            | 4           | XX-XX                    | X                                |
| 21                          | 32                    | X            | 4           | XX-XX                    | X                                |
| 21                          | 37                    | X            | 4           | XX-XX                    | X                                |

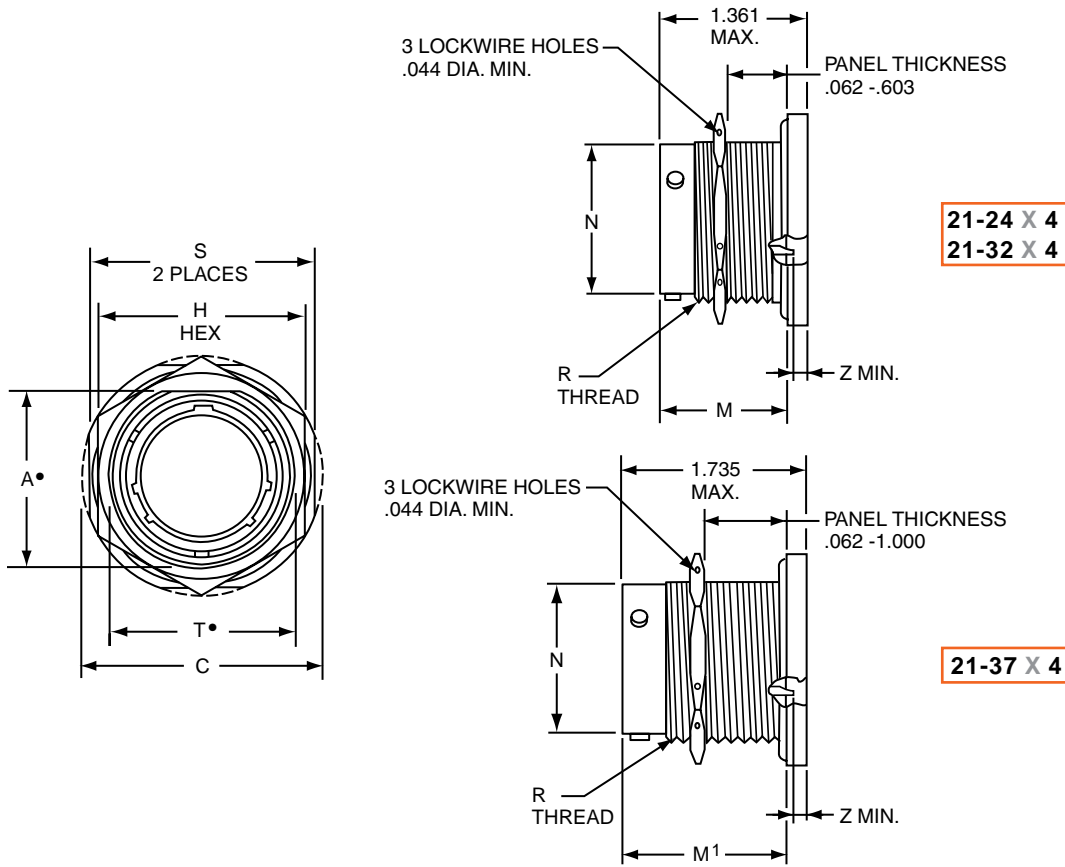

• "D" shaped mounting hole dimensions  
Plug movement required to clear FJT receptacles: .281 min.

| Shell Size | A* Flat<br>+.000<br>-.010 | C Dia.<br>+.011<br>-.010 | H Hex<br>+.017<br>-.016 | M<br>±.005 | M1<br>±.005 | N Dia<br>+.001<br>-.005 | R Thread<br>UNEF-2A<br>(Plated) | S<br>+.011<br>-.010 | T* Dia.<br>+.010<br>-.000 | SHORT SHELL<br>VHF/UHF/MF Filters     |                           |                           | LONG SHELL<br>HF Filters              |                           |
|------------|---------------------------|--------------------------|-------------------------|------------|-------------|-------------------------|---------------------------------|---------------------|---------------------------|---------------------------------------|---------------------------|---------------------------|---------------------------------------|---------------------------|
|            |                           |                          |                         |            |             |                         |                                 |                     |                           | Size 16 or 16 & 20 Contacts<br>Z Max. | Size 20 Contact<br>Z Max. | Size 22 Contact<br>Z Max. | Size 16 or 16 & 20 Contacts<br>Z Max. | Size 20 Contact<br>Z Max. |
| 8          | .542                      | 1.062                    | .750                    | 1.220      | 1.594       | .473                    | .5625-24                        | .938                | .572                      | .000                                  | .022                      | .057                      | .000                                  | .000                      |
| 10         | .669                      | 1.188                    | .875                    | 1.220      | 1.594       | .590                    | .6875-24                        | 1.062               | .697                      | .000                                  | .022                      | .057                      | .000                                  | .000                      |
| 12         | .830                      | 1.375                    | 1.062                   | 1.220      | 1.594       | .750                    | .8750-20                        | 1.250               | .844                      | .000                                  | .022                      | .057                      | .000                                  | .000                      |
| 14         | .955                      | 1.500                    | 1.188                   | 1.220      | 1.594       | .875                    | 1.0000-20                       | 1.375               | 1.007                     | .000                                  | .022                      | .057                      | .000                                  | .000                      |
| 16         | 1.084                     | 1.625                    | 1.312                   | 1.220      | 1.594       | 1.000                   | 1.1250-18                       | 1.500               | 1.134                     | .000                                  | .022                      | .057                      | .000                                  | .000                      |
| 18         | 1.208                     | 1.750                    | 1.438                   | 1.220      | 1.594       | 1.125                   | 1.2500-18                       | 1.625               | 1.259                     | .000                                  | .022                      | .057                      | .000                                  | .000                      |
| 20         | 1.333                     | 1.938                    | 1.562                   | 1.188      | 1.563       | 1.250                   | 1.3750-18                       | 1.812               | 1.384                     | .000                                  | .022                      | .057                      | .000                                  | .000                      |
| 22         | 1.459                     | 2.062                    | 1.688                   | 1.188      | 1.563       | 1.375                   | 1.5000-18                       | 1.938               | 1.507                     | .000                                  | .022                      | .057                      | .000                                  | .000                      |
| 24         | 1.575                     | 2.188                    | 1.812                   | 1.188      | 1.563       | 1.500                   | 1.6250-18                       | 2.062               | 1.634                     | .000                                  | .022                      | .057                      | .000                                  | .000                      |

All dimensions for reference only.

- III 38999
- II
- I
- SJT
- Matrix 2 26482
- Matrix 83723 III
- Pyle
- 5015 Crimp Rear Release Matrix
- 26500 Pyle
- Printed Circuit Board
- EMI Filter Transient
- Fiber Optics
- High Speed Contacts
- Options Others

38999  
SJT I II III

26482  
Matrix 2

83723 III  
Matrix Pyle

5015  
Crimp Rear  
Release Matrix

26500 Pyle

Printed  
Circuit Board

EMI Filter  
Transient

Fiber Optics

High Speed  
Contacts

Options  
Others

The Amphenol® FLJT Series offers all the design features of the FJT plus a 100% “scoop-proof” contact protection design.

- Intermountable with MIL-DTL-38999/27599 Series I connectors (see section Series I LJT)
- Contact Protection - shell design prevents contact damage
- Quick Positive Coupling – 3 point bayonet locking
- Higher reliability and greater durability with permanently encapsulated contacts
- Environmental Resistant
- Aluminum shells with several finish options
- Error-proof alternate positioning of shell keyways
- Corrosion Resistant - 500 hour salt spray olive drab cadmium over nickel plating, class T (aluminum), electroless nickel plating, class F (aluminum) or stainless steel shells



**FLJT Master Key/Keyway Rotation**

| Shell Size | AB Angle of Rotation (Degrees) |    |    |     |     |
|------------|--------------------------------|----|----|-----|-----|
|            | Normal                         | A  | B  | C   | D   |
| 9          | 95                             | 77 | –  | –   | 113 |
| 11         | 95                             | 81 | 67 | 123 | 109 |
| 13         | 95                             | 75 | 63 | 127 | 115 |
| 15         | 95                             | 74 | 61 | 129 | 116 |
| 17         | 95                             | 77 | 65 | 125 | 113 |
| 19         | 95                             | 77 | 65 | 125 | 113 |
| 21         | 95                             | 77 | 65 | 125 | 113 |
| 23         | 95                             | 80 | 69 | 121 | 110 |
| 25         | 95                             | 80 | 69 | 121 | 110 |

A plug with a given rotation letter will mate with a receptacle with the same rotation letter. The AB angle for a given connector is the same whether it contains pins or sockets. Inserts are not rotated in conjunction with the master key/keyway.

AB angles shown are viewed from the front face of the connector. A receptacle is shown at right. The angles for the plug are exactly the same, except the direction of rotation is opposite of that shown for the receptacle.

**FLJT**

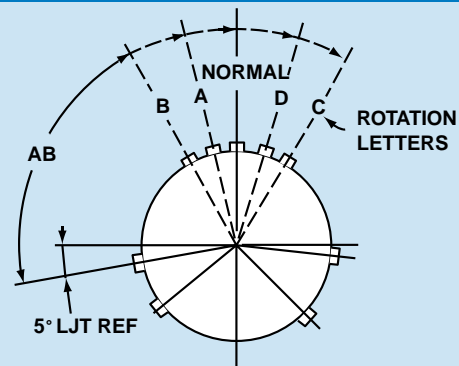

**RELATIVE POSSIBLE POSITION OF ROTATED MASTER KEYWAY (front face of receptacle shown)**



# FLJT – MIL-DTL-38999, Series I

## Wall Mounting Receptacle - Aluminum



**PART #**  
To complete, see how to order pages 288-289.

| Filter Connector Designator | Connector Filter Type | Shell Finish | Shell Style | Shell Size & Insert Arrg | Type of Contact/ Keyway Position |
|-----------------------------|-----------------------|--------------|-------------|--------------------------|----------------------------------|
| 21                          | 29                    | X            | 0           | XX-XX                    | X                                |
| 21                          | 40                    | X            | 0           | XX-XX                    | X                                |
| 21                          | 36                    | X            | 0           | XX-XX                    | X                                |

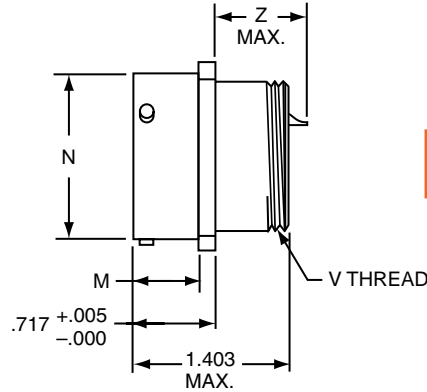
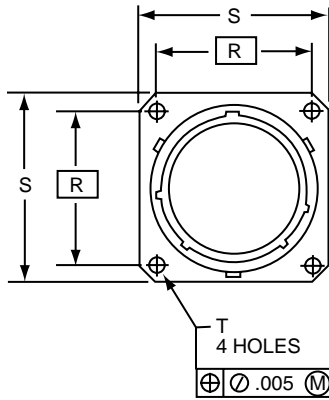

**21-29X0**  
**21-40X0**

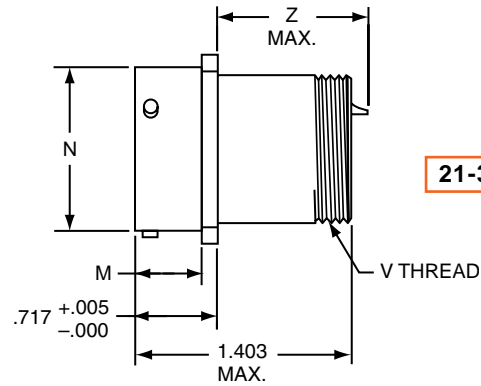

**21-36X0**

Plug movement required to clear FLJT receptacles: .625 min.

| Shell Size | M<br>+.000<br>-.006 | N Dia.<br>+.001<br>-.005 | R<br>(TP) | S<br>+.011<br>-.010 | T<br>Dia.<br>±.005 | V<br>Thread<br>UNEF-2A<br>(Plated) | SHORT SHELL<br>VHF/UHF/MF Filters |   |                              | LONG SHELL<br>HF Filters     |   |
|------------|---------------------|--------------------------|-----------|---------------------|--------------------|------------------------------------|-----------------------------------|---|------------------------------|------------------------------|---|
|            |                     |                          |           |                     |                    |                                    | Size 20<br>Contact<br>Z Max.      | Size 16 or<br>16 & 20<br>Contacts<br>Z Max. | Size 22<br>Contact<br>Z Max. | Size 20<br>Contact<br>Z Max. | Size 16 or<br>16 & 20<br>Contacts<br>Z Max. |
| 9          | .632                | .572                     | .719      | .938                | .128               | .4375-28                           | .865                              | .950  | .820                         | 1.324                        | 1.394                                       |
| 11         | .632                | .700                     | .812      | 1.031               | .128               | .5625-24                           | .865                              | .950  | .820                         | 1.324                        | 1.394                                       |
| 13         | .632                | .850                     | .906      | 1.125               | .128               | .6875-24                           | .865                              | .950  | .820                         | 1.324                        | 1.394                                       |
| 15         | .632                | .975                     | .969      | 1.219               | .128               | .8125-20                           | .865                              | .950  | .820                         | 1.324                        | 1.394                                       |
| 17         | .632                | 1.100                    | 1.062     | 1.312               | .128               | .9375-20                           | .865                              | .950  | .820                         | 1.324                        | 1.394                                       |
| 19         | .632                | 1.207                    | 1.156     | 1.438               | .128               | 1.0625-18                          | .865                              | .950  | .820                         | 1.324                        | 1.394                                       |
| 21         | .602                | 1.332                    | 1.250     | 1.562               | .128               | 1.1875-18                          | .865                              | .950  | .820                         | 1.324                        | 1.394                                       |
| 23         | .602                | 1.457                    | 1.375     | 1.688               | .147               | 1.3125-18                          | .865                              | .950  | .820                         | 1.324                        | 1.394                                       |
| 25         | .602                | 1.582                    | 1.500     | 1.812               | .147               | 1.4375-18                          | .865                              | .950  | .820                         | 1.324                        | 1.394                                       |

All dimensions for reference only.

- III 38999
- II
- I
- SJT
- 26482 Matrix 2
- 83723 III Matrix Pyle
- 5015 Crimp Rear Release Matrix
- 26500 Pyle
- Printed Circuit Board
- EMI Filter Transient
- Fiber Optics
- High Speed Contacts
- Options Others

38999  
SJT I II III

26482  
Matrix 2

83723 III  
Matrix Pyle

5015  
Crimp Rear Release Matrix

26500 Pyle

Printed  
Circuit Board

EMI Filter  
Transient

Fiber Optics

High Speed  
Contacts

Options  
Others

**PART #**

To complete, see how to order pages 288-289.

| Filter Connector Designator | Connector Filter Type | Shell Finish | Shell Style | Shell Size & Insert Arrg | Type of Contact/ Keyway Position |
|-----------------------------|-----------------------|--------------|-------------|--------------------------|----------------------------------|
| 21                          | 47                    | X            | 0           | XX-XX                    | X                                |
| 21                          | 48                    | X            | 0           | XX-XX                    | X                                |

**UTS (Crimp) Contact SAE AS39029/57**

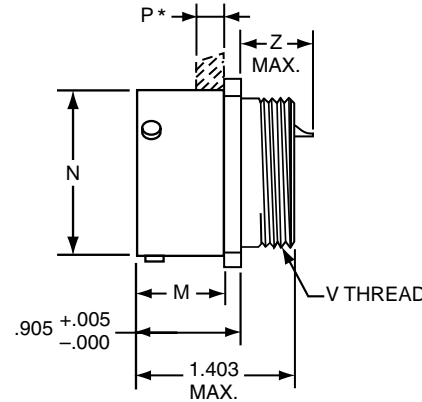
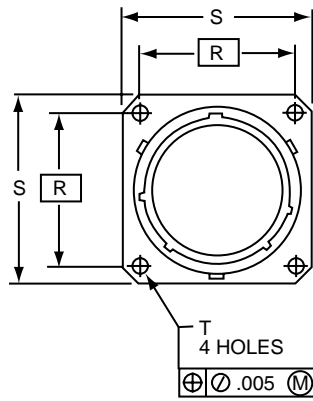

**21-47X0**

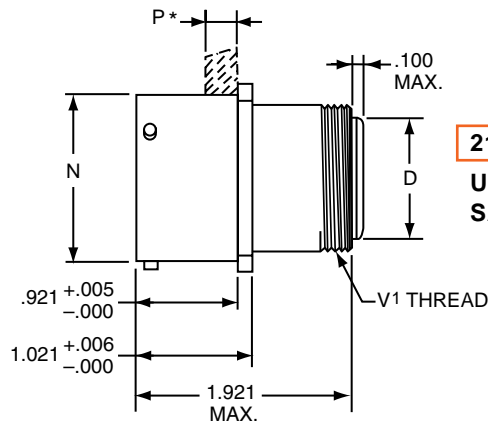

**21-48X0**

**UTS (Crimp) Contact  
SAE AS39029/57**

Plug movement required to clear FLJT receptacles: .625 min.  
\* Acceptable panel thickness for back panel mounting a standard receptacle.

| Shell Size | D Dia. ±.005 | M +.000 - .006 | N Dia. +.001 - .005 | P Max. Panel Thickness | R (TP) | S +.011 - .010 | T Dia. ±.005 | V Thread UNEF-2A (Plated) | V' Thread UNEF-2A (Plated) | SHORT SHELL VHF/UHF Filters |                               |                        |
|------------|--------------|----------------|---------------------|------------------------|--------|----------------|--------------|---------------------------|----------------------------|-----------------------------|-------------------------------|------------------------|
|            |              |                |                     |                        |        |                |              |                           |                            | Size 20 Contact Z Max.      | Size 16 or 20 Contacts Z Max. | Size 22 Contact Z Max. |
| 9          | .299         | .820           | .572                | .234                   | .719   | .938           | .128         | .4375-28                  | .5625-24                   | .672                        | .763                          | .632                   |
| 11         | .427         | .820           | .700                | .234                   | .812   | 1.031          | .128         | .5625-24                  | .6875-24                   | .672                        | .763                          | .632                   |
| 13         | .541         | .820           | .850                | .234                   | .906   | 1.125          | .128         | .6875-24                  | .8125-20                   | .672                        | .763                          | .632                   |
| 15         | .666         | .820           | .975                | .234                   | .969   | 1.219          | .128         | .8125-20                  | .9375-20                   | .672                        | .763                          | .632                   |
| 17         | .791         | .820           | 1.100               | .234                   | 1.062  | 1.312          | .128         | .9375-20                  | 1.0625-18                  | .672                        | .763                          | .632                   |
| 19         | .897         | .820           | 1.207               | .234                   | 1.156  | 1.438          | .128         | 1.0625-18                 | 1.1875-18                  | .672                        | .763                          | .632                   |
| 21         | 1.022        | .790           | 1.332               | .204                   | 1.250  | 1.562          | .128         | 1.1875-18                 | 1.3125-18                  | .672                        | .763                          | .632                   |
| 23         | 1.147        | .790           | 1.457               | .204                   | 1.375  | 1.688          | .147         | 1.3125-18                 | 1.4375-18                  | .672                        | .763                          | .632                   |
| 25         | 1.272        | .790           | 1.582               | .193                   | 1.500  | 1.812          | .147         | 1.4375-18                 | 1.5625-18                  | .672                        | .763                          | .632                   |

All dimensions for reference only.

# FLJT – MIL-DTL-38999, Series I

## Box Mounting Receptacle - Aluminum



### PART #

To complete, see how to order pages 288-289.

| Filter Connector Designator | Connector Filter Type | Shell Finish | Shell Style | Shell Size & Insert Arrg | Type of Contact/ Keyway Position |
|-----------------------------|-----------------------|--------------|-------------|--------------------------|----------------------------------|
| 21                          | 29                    | X            | 2           | XX-XX                    | X                                |
| 21                          | 40                    | X            | 2           | XX-XX                    | X                                |
| 21                          | 36                    | X            | 2           | XX-XX                    | X                                |

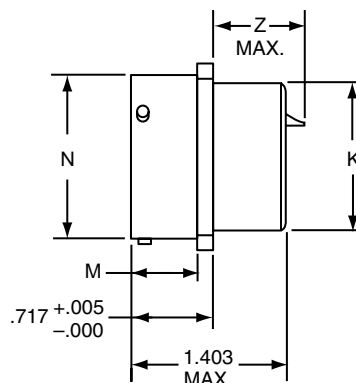
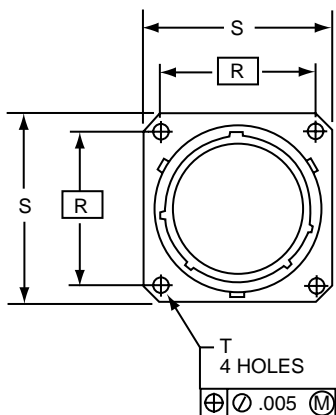

21-29X2  
21-40X2

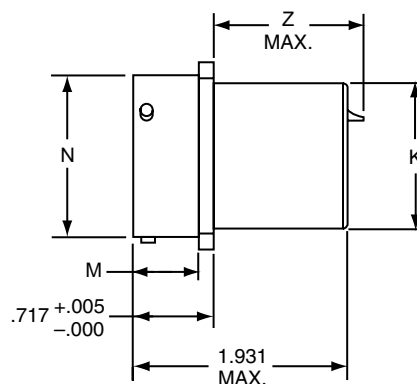

21-36X2

Plug movement required to clear FLJT receptacles: .625 min.

| Shell Size | K Dia. +.001 / -.006 | M +.000 / -.006 | N Dia. +.001 / -.005 | R (TP) | S +.011 / -.010 | T Dia. ±.005 | SHORT SHELL VHF/UHF/MF Filters |                                    |                        | LONG SHELL HF Filters  |                                    |
|------------|----------------------|-----------------|----------------------|--------|-----------------|--------------|--------------------------------|------------------------------------|------------------------|------------------------|------------------------------------|
|            |                      |                 |                      |        |                 |              | Size 20 Contact Z Max.         | Size 16 or 16 & 20 Contacts Z Max. | Size 22 Contact Z Max. | Size 20 Contact Z Max. | Size 16 or 16 & 20 Contacts Z Max. |
| 9          | .436                 | .632            | .572                 | .719   | .938            | .128         | .865                           | .950                               | .820                   | 1.324                  | 1.394                              |
| 11         | .560                 | .632            | .700                 | .812   | 1.031           | .128         | .865                           | .950                               | .820                   | 1.324                  | 1.394                              |
| 13         | .686                 | .632            | .850                 | .906   | 1.125           | .128         | .865                           | .950                               | .820                   | 1.324                  | 1.394                              |
| 15         | .810                 | .632            | .975                 | .969   | 1.219           | .128         | .865                           | .950                               | .820                   | 1.324                  | 1.394                              |
| 17         | .936                 | .632            | 1.100                | 1.062  | 1.312           | .128         | .865                           | .950                               | .820                   | 1.324                  | 1.394                              |
| 19         | 1.060                | .632            | 1.207                | 1.156  | 1.438           | .128         | .865                           | .950                               | .820                   | 1.324                  | 1.394                              |
| 21         | 1.186                | .602            | 1.332                | 1.250  | 1.562           | .128         | .865                           | .950                               | .820                   | 1.324                  | 1.394                              |
| 23         | 1.310                | .602            | 1.457                | 1.375  | 1.688           | .147         | .865                           | .950                               | .820                   | 1.324                  | 1.394                              |
| 25         | 1.436                | .602            | 1.582                | 1.500  | 1.812           | .147         | .865                           | .950                               | .820                   | 1.324                  | 1.394                              |

All dimensions for reference only.

38999 III II I SJT

26482 Matrix 2

83723 III Matrix Pyle

5015 Crimp Rear Release Matrix

26500 Pyle

Printed Circuit Board

EMI Filter Transient

Fiber Optics

High Speed Contacts

Options Others

38999  
SJT I II III

26482  
Matrix 2

83723 III  
Matrix Pyle

5015  
Crimp Rear  
Release Matrix

26500 Pyle

Printed  
Circuit Board

EMI Filter  
Transient

Fiber Optics

High Speed  
Contacts

Options  
Others

**PART #**  
To complete, see how to order pages 288-289.

| Filter Connector Designator | Connector Filter Type | Shell Finish | Shell Style | Shell Size & Insert Arrg | Type of Contact/ Keyway Position |
|-----------------------------|-----------------------|--------------|-------------|--------------------------|----------------------------------|
| 21                          | 47                    | X            | 2           | XX-XX                    | X                                |
| 21                          | 48                    | X            | 2           | XX-XX                    | X                                |

**UTS (Crimp) Contact SAE AS39029**

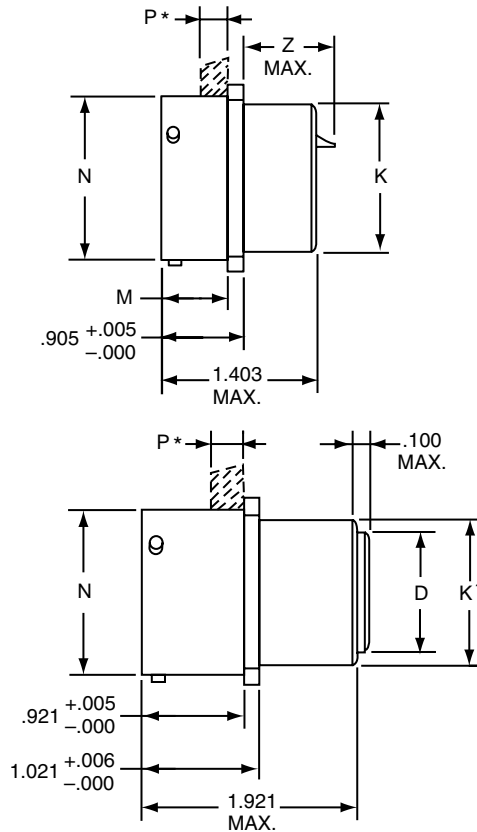
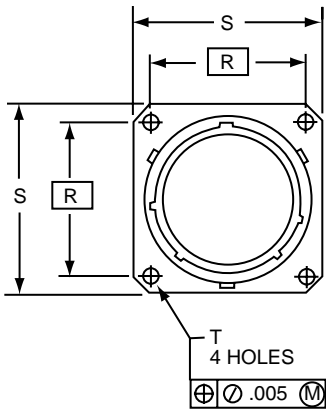

**21-47X2**

**21-48X2**

**UTS (Crimp) Contact  
SAE AS39029**

Plug movement required to clear FLJT receptacles: .625 min.  
\* Acceptable panel thickness for back panel mounting a standard receptacle.

| Shell Size | D Dia. ±.005 | K Dia. +.000 - .006 | K' Dia. +.000 - .007 | M +.000 - .006 | N Dia. +.001 - .005 | P Max. Panel Thickness | R (TP) | S +.011 - .010 | T Dia. ±.005 | SHORT SHELL VHF/UHF Filters |                                    |                        |
|------------|--------------|---------------------|----------------------|----------------|---------------------|------------------------|--------|----------------|--------------|-----------------------------|------------------------------------|------------------------|
|            |              |                     |                      |                |                     |                        |        |                |              | Size 20 Contact Z Max.      | Size 16 or 18 & 20 Contacts Z Max. | Size 22 Contact Z Max. |
| 9          | .299         | .437                | .561                 | .820           | .572                | .234                   | .719   | .938           | .128         | .672                        | .763                               | .632                   |
| 11         | .427         | .562                | .687                 | .820           | .700                | .234                   | .812   | 1.031          | .128         | .672                        | .763                               | .632                   |
| 13         | .541         | .688                | .811                 | .820           | .850                | .234                   | .906   | 1.125          | .128         | .672                        | .763                               | .632                   |
| 15         | .666         | .812                | .937                 | .820           | .975                | .234                   | .969   | 1.219          | .128         | .672                        | .763                               | .632                   |
| 17         | .791         | .938                | 1.061                | .820           | 1.100               | .234                   | 1.062  | 1.312          | .128         | .672                        | .763                               | .632                   |
| 19         | .897         | 1.062               | 1.187                | .820           | 1.207               | .234                   | 1.156  | 1.438          | .128         | .672                        | .763                               | .632                   |
| 21         | 1.022        | 1.188               | 1.312                | .790           | 1.332               | .204                   | 1.250  | 1.562          | .128         | .672                        | .763                               | .632                   |
| 23         | 1.147        | 1.312               | 1.437                | .790           | 1.457               | .204                   | 1.375  | 1.688          | .147         | .672                        | .763                               | .632                   |
| 25         | 1.272        | 1.438               | 1.562                | .790           | 1.582               | .193                   | 1.500  | 1.812          | .147         | .672                        | .763                               | .632                   |

All dimensions for reference only.

# FLJT – MIL-DTL-38999, Series I

## Box Mounting Receptacle - Aluminum

(Printed Circuit Board Mount)

**PART #** To complete, see how to order pages 288-289.

| Filter Connector Designator | Connector Filter Type | Shell Finish | Shell Style | Shell Size & Insert Arrg | Type of Contact/Keyway Position |
|-----------------------------|-----------------------|--------------|-------------|--------------------------|---------------------------------|
| 21                          | 57                    | X            | 2           | XX-XX                    | X                               |

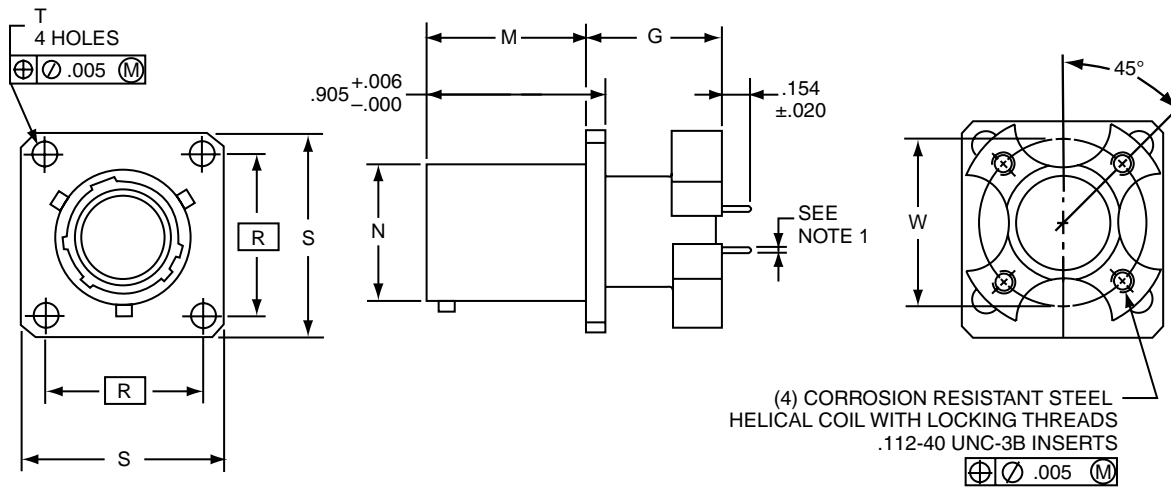

(4) CORROSION RESISTANT STEEL  
HELICAL COIL WITH LOCKING THREADS  
.112-40 UNC-3B INSERTS  
 $\pm .005$  M

21-57X2

- 1. Standard tail for size 22 is  $.020 \pm .001$  dia.
- Standard tail for size 20 is  $.030 \pm .001$  dia.
- Plug movement required to clear FLJT receptacles:  $.625$  min.

| Shell Size | G<br>+.006<br>-.005 | M<br>+.000<br>-.005 | N Dia.<br>+.001<br>-.005 | R<br>(TP) | S<br>+.011<br>-.010 | T Dia.<br>+.004<br>-.003 | W     |
|------------|---------------------|---------------------|--------------------------|-----------|---------------------|--------------------------|-------|
| 11         | .689                | .820                | .700                     | .812      | 1.031               | .128                     | .850  |
| 13         | .689                | .820                | .850                     | .906      | 1.125               | .128                     | .994  |
| 15         | .689                | .820                | .975                     | .969      | 1.219               | .128                     | 1.119 |
| 17         | .689                | .820                | 1.100                    | 1.062     | 1.312               | .128                     | 1.237 |
| 19         | .689                | .820                | 1.207                    | 1.156     | 1.438               | .128                     | 1.379 |
| 21         | .689                | .790                | 1.332                    | 1.250     | 1.562               | .128                     | 1.489 |
| 23         | .719                | .790                | 1.457                    | 1.375     | 1.688               | .147                     | 1.619 |
| 25         | .719                | .790                | 1.582                    | 1.500     | 1.812               | .147                     | 1.744 |

All dimensions for reference only.

|     |                           |
|-----|---------------------------|
| III | 38999                     |
| II  | 26482                     |
| I   | Matrix 2                  |
| SJT | 83723 III                 |
|     | Matrix Pyle               |
|     | 5015                      |
|     | Crimp Rear Release Matrix |
|     | 26500 Pyle                |
|     | Printed Circuit Board     |
|     | EMI Filter Transient      |
|     | Fiber Optics              |
|     | High Speed Contacts       |
|     | Options Others            |

38999  
SJT I II III

26482  
Matrix 2

83723 III  
Matrix Pyle

5015  
Crimp Rear  
Release Matrix

26500 Pyle

Printed  
Circuit Board

EMI Filter  
Transient

Fiber Optics

High Speed  
Contacts

Options  
Others

### PART #

To complete,  
see how to order  
pages 288-289.

| Filter Connector Designator | Connector Filter Type | Shell Finish | Shell Style | Shell Size & Insert Arrg | Type of Contact/ Keyway Position |
|-----------------------------|-----------------------|--------------|-------------|--------------------------|----------------------------------|
| 21                          | 29                    | X            | 7           | XX-XX                    | X                                |
| 21                          | 40                    | X            | 7           | XX-XX                    | X                                |
| 21                          | 36                    | X            | 7           | XX-XX                    | X                                |

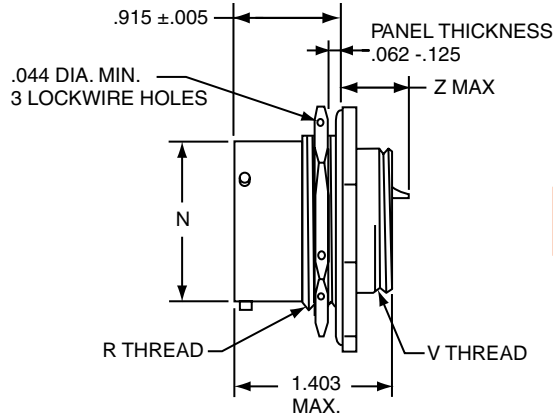
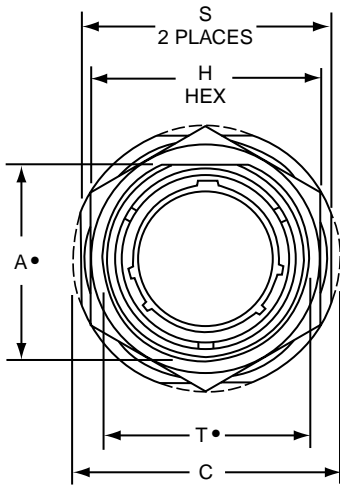

**21-29X7**  
**21-40X7**

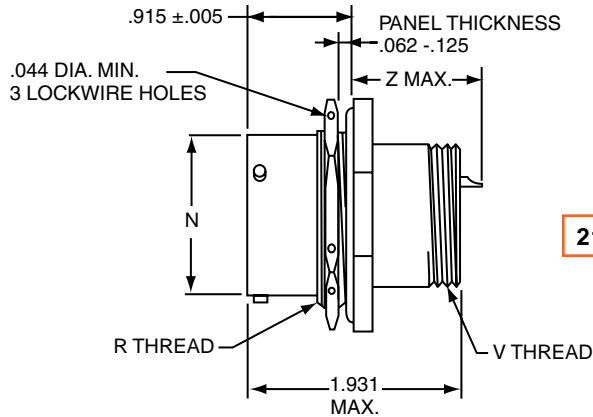

**21-36X7**

- "D" shaped mounting hole dimensions  
Plug movement required to clear FLJT receptacles: .625 min.

| Shell Size | A* Flat<br>+.000<br>-.010 | C Dia.<br>+.011<br>-.010 | H Hex<br>+.017<br>-.016 | N Dia<br>+.001<br>-.005 | R Thread<br>(Plated)<br>Class -2A | S<br>+.016<br>-.015 | T* Dia.<br>+.010<br>-.000 | V Thread<br>UNEF-2A<br>(Plated) | SHORT SHELL<br>VHF/UHF/MF Filters |   |                           | LONG SHELL<br>HF Filters  |   |
|------------|---------------------------|--------------------------|-------------------------|-------------------------|-----------------------------------|---------------------|---------------------------|---------------------------------|-----------------------------------|---|---------------------------|---------------------------|---|
|            |                           |                          |                         |                         |                                   |                     |                           |                                 | Size 20 Contact<br>Z Max.         | Size 16 or<br>16 & 20<br>Contacts<br>Z Max. | Size 22 Contact<br>Z Max. | Size 20 Contact<br>Z Max. | Size 16 or<br>16 & 20<br>Contacts<br>Z Max. |
| 9          | .669                      | 1.188                    | .875                    | .572                    | .6875-24UNEF                      | 1.062               | .697                      | .4375-28                        | .667                              | .756  | .616                      | 1.228                     | 1.201                                       |
| 11         | .769                      | 1.375                    | 1.000                   | .700                    | .8125-20UNEF                      | 1.250               | .822                      | .5625-24                        | .667                              | .756  | .616                      | 1.228                     | 1.201                                       |
| 13         | .955                      | 1.500                    | 1.188                   | .850                    | 1.0000-20UNEF                     | 1.375               | 1.007                     | .6875-24                        | .667                              | .756  | .616                      | 1.228                     | 1.201                                       |
| 15         | 1.084                     | 1.625                    | 1.312                   | .975                    | 1.1250-18UNEF                     | 1.500               | 1.134                     | .8125-20                        | .667                              | .756  | .616                      | 1.228                     | 1.201                                       |
| 17         | 1.208                     | 1.750                    | 1.438                   | 1.100                   | 1.2500-18UNEF                     | 1.625               | 1.259                     | .9375-20                        | .667                              | .756  | .616                      | 1.228                     | 1.201                                       |
| 19         | 1.333                     | 1.938                    | 1.562                   | 1.207                   | 1.3750-18UNEF                     | 1.812               | 1.384                     | 1.0625-18                       | .667                              | .756  | .616                      | 1.228                     | 1.201                                       |
| 21         | 1.459                     | 2.062                    | 1.688                   | 1.332                   | 1.5000-18UNEF                     | 1.938               | 1.507                     | 1.1875-18                       | .667                              | .756  | .616                      | 1.228                     | 1.201                                       |
| 23         | 1.580                     | 2.188                    | 1.812                   | 1.457                   | 1.6250-18UNEF                     | 2.062               | 1.634                     | 1.3125-18                       | .667                              | .756  | .616                      | 1.228                     | 1.201                                       |
| 25         | 1.709                     | 2.312                    | 2.000                   | 1.582                   | 1.7500-18UNS                      | 2.188               | 1.759                     | 1.4375-18                       | .667                              | .756  | .616                      | 1.228                     | 1.201                                       |

All dimensions for reference only.



**PART #** To complete, see how to order pages 288-289.

| Filter Connector Designator | Connector Filter Type | Shell Finish | Shell Style | Shell Size & Insert Arrg | Type of Contact/Keyway Position |
|-----------------------------|-----------------------|--------------|-------------|--------------------------|---------------------------------|
| 21                          | 48                    | X            | 7           | XX-XX                    | X                               |

**UTS (Crimp) Contact SAE AS39029/57**

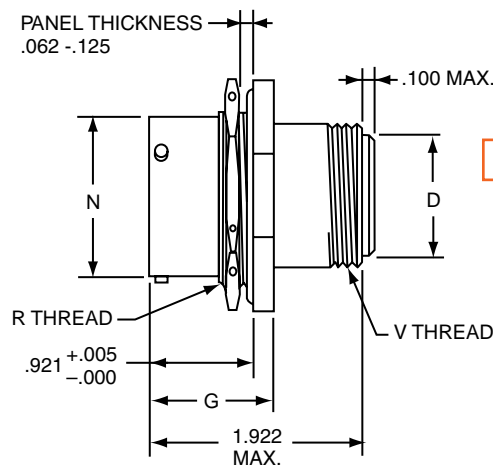
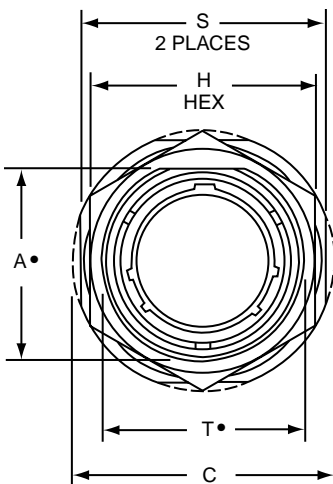

**21-48X7**  
**UTS (Crimp) Contact**  
**SAE AS39029/57**

• "D" shaped mounting hole dimensions  
 Plug movement required to clear FLJT receptacles: .625 min.

| Shell Size | A* Flat<br>+.000<br>-.010 | C Dia.<br>+.011<br>-.010 | D Dia.<br>±.005 | G<br>+.006<br>-.005 | H Hex<br>+.017<br>-.016 | N Dia<br>+.001<br>-.005 | R Thread (Plated) Class -2A | S<br>+.016<br>-.015 | T* Dia.<br>+.010<br>-.000 | V Thread UNEF-2A (Plated) |
|------------|---------------------------|--------------------------|-----------------|---------------------|-------------------------|-------------------------|-----------------------------|---------------------|---------------------------|---------------------------|
| 9          | .669                      | 1.188                    | .299            | 1.030               | .875                    | .572                    | .6875-24UNEF                | 1.062               | .697                      | .5625-24                  |
| 11         | .769                      | 1.375                    | .427            | 1.030               | 1.000                   | .700                    | .8125-20UNEF                | 1.250               | .822                      | .6875-24                  |
| 13         | .955                      | 1.500                    | .541            | 1.030               | 1.188                   | .850                    | 1.0000-20UNEF               | 1.375               | 1.007                     | .8125-20                  |
| 15         | 1.084                     | 1.625                    | .666            | 1.030               | 1.312                   | .975                    | 1.1250-18UNEF               | 1.500               | 1.134                     | .9375-20                  |
| 17         | 1.208                     | 1.750                    | .791            | 1.030               | 1.438                   | 1.100                   | 1.2500-18UNEF               | 1.625               | 1.259                     | 1.0625-18                 |
| 19         | 1.333                     | 1.938                    | .897            | 1.061               | 1.562                   | 1.207                   | 1.3750-18UNEF               | 1.812               | 1.384                     | 1.1875-18                 |
| 21         | 1.459                     | 2.062                    | 1.022           | 1.061               | 1.688                   | 1.332                   | 1.5000-18UNEF               | 1.938               | 1.507                     | 1.3125-18                 |
| 23         | 1.580                     | 2.188                    | 1.147           | 1.061               | 1.812                   | 1.457                   | 1.6250-18UNEF               | 2.062               | 1.634                     | 1.4375-18                 |
| 25         | 1.709                     | 2.312                    | 1.272           | 1.061               | 2.000                   | 1.582                   | 1.7500-18UNS                | 2.188               | 1.759                     | 1.5625-18                 |

All dimensions for reference only.

38999  
SJT

26482  
Matrix 2

83723 III  
Matrix Pyle

5015  
Crimp Rear Release Matrix

26500 Pyle

Printed  
Circuit Board

EMI Filter  
Transient

Fiber Optics

High Speed  
Contacts

Options  
Others

## FLJT – MIL-DTL-38999, Series I Jam Mounting Receptacle - Aluminum (Printed Circuit Board Mount)

- 38999  
SJT I II III
- 26482  
Matrix 2
- 83723 III  
Matrix Pyle
- 5015  
Crimp Rear Release Matrix
- 26500 Pyle
- Printed  
Circuit Board
- EMI Filter  
Transient
- Fiber Optics
- High Speed  
Contacts
- Options  
Others

### PART #

To complete, see how to order pages 288-289.

| Filter Connector Designator | Connector Filter Type | Shell Finish | Shell Style | Shell Size & Insert Arrg | Type of Contact/ Keyway Position |
|-----------------------------|-----------------------|--------------|-------------|--------------------------|----------------------------------|
| 21                          | 57                    | X            | 4           | XX-XX                    | X                                |
| 21                          | 57                    | X            | 7           | XX-XX                    | X                                |

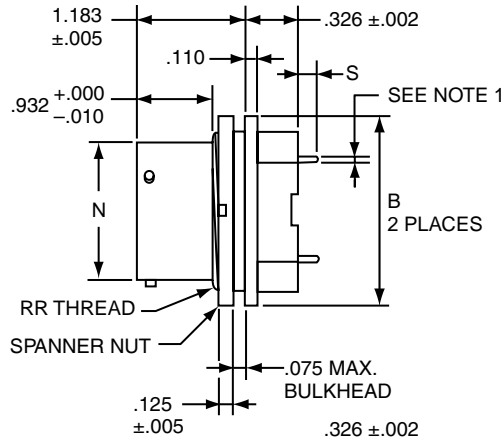
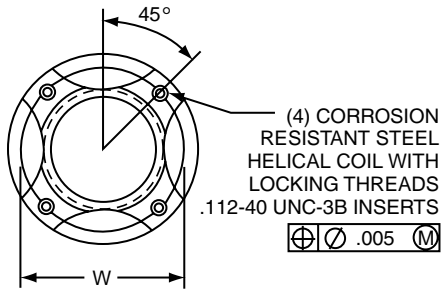

21-57X4

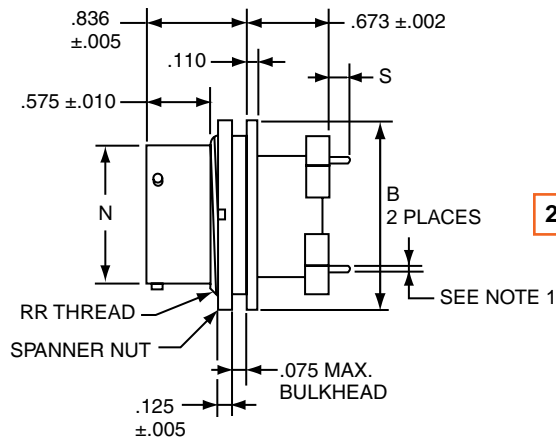

21-57X7

Note 1. Standard tail for size 22 is .020 ±.001 dia.  
Standard tail for size 20 is .030 ±.001 dia.  
Plug movement required to clear FLJT receptacles: .625 min.

| Shell Size | B Dia. ±.005 | N Dia. +.001 / -.005 | S ±.020 | W     | RR Thread UNEF-2A |
|------------|--------------|----------------------|---------|-------|-------------------|
| 11         | 1.062        | .700                 | .132    | .850  | .8125-20          |
| 13         | 1.250        | .850                 | .132    | .994  | 1.0000-20         |
| 15         | 1.375        | .975                 | .132    | 1.119 | 1.1250-20         |
| 17         | 1.500        | 1.100                | .132    | 1.237 | 1.2500-18         |
| 19         | 1.625        | 1.207                | .132    | 1.379 | 1.3750-18         |
| 21         | 1.750        | 1.332                | .132    | 1.489 | 1.5000-18         |
| 23         | 1.875        | 1.457                | .132    | 1.619 | 1.6250-18         |
| 25         | 2.000        | 1.582                | .132    | 1.744 | 1.7500-18         |

All dimensions for reference only.

# FLJT – MIL-DTL-38999, Series I

## Jam Nut Receptacle - Aluminum

(Minimum Penetration)

**PART #** To complete, see how to order pages 288.-289

| Filter Connector Designator | Connector Filter Type | Shell Finish | Shell Style | Shell Size & Insert Arrg | Type of Contact/ Keyway Position |
|-----------------------------|-----------------------|--------------|-------------|--------------------------|----------------------------------|
| 21                          | 29                    | X            | 4           | XX-XX                    | X                                |

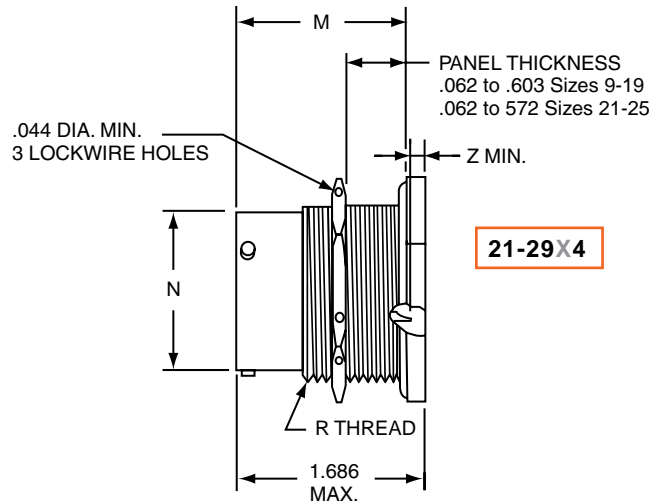
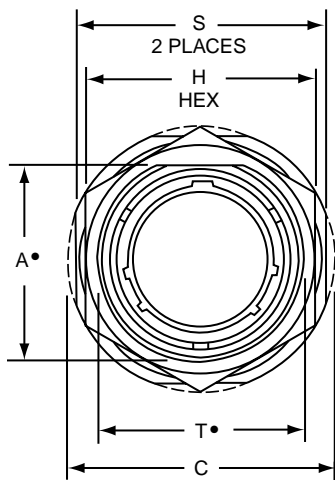

**21-29X4**

• "D" shaped mounting hole dimensions  
 Plug movement required to clear FLJT receptacles: .625 min.

| Shell Size | A* Flat<br>+.000<br>-.010 | C Dia.<br>+.011<br>-.010 | H Hex<br>+.017<br>-.016 | M<br>±.005 | N Dia<br>+.001<br>-.005 | R Thread<br>(Plated)<br>Class -2A | S<br>+.016<br>-.015 | T* Dia.<br>+.010<br>-.000 | SHORT SHELL<br>VHF/UHF Filters |                                       |                           |                           |
|------------|---------------------------|--------------------------|-------------------------|------------|-------------------------|-----------------------------------|---------------------|---------------------------|--------------------------------|---------------------------------------|---------------------------|---------------------------|
|            |                           |                          |                         |            |                         |                                   |                     |                           | Size 16 Contact<br>Z Max.      | Size 16 or 16 & 20 Contacts<br>Z Max. | Size 20 Contact<br>Z Max. | Size 22 Contact<br>Z Max. |
| 9          | .669                      | 1.188                    | .875                    | 1.557      | .572                    | .6875-24UNEF                      | 1.062               | .697                      | .000                           | .000                                  | .000                      | .000                      |
| 11         | .769                      | 1.375                    | 1.000                   | 1.557      | .700                    | .8125-20UNEF                      | 1.250               | .822                      | .000                           | .000                                  | .000                      | .000                      |
| 13         | .955                      | 1.500                    | 1.188                   | 1.557      | .850                    | 1.0000-20UNEF                     | 1.375               | 1.007                     | .000                           | .000                                  | .000                      | .000                      |
| 15         | 1.084                     | 1.625                    | 1.312                   | 1.557      | .975                    | 1.1250-18UNEF                     | 1.500               | 1.134                     | .000                           | .000                                  | .000                      | .000                      |
| 17         | 1.208                     | 1.750                    | 1.438                   | 1.557      | 1.100                   | 1.2500-18UNEF                     | 1.625               | 1.259                     | .000                           | .000                                  | .000                      | .000                      |
| 19         | 1.333                     | 1.938                    | 1.562                   | 1.557      | 1.207                   | 1.3750-18UNEF                     | 1.812               | 1.384                     | .000                           | .000                                  | .000                      | .000                      |
| 21         | 1.459                     | 2.062                    | 1.688                   | 1.525      | 1.332                   | 1.5000-18UNEF                     | 1.938               | 1.507                     | .000                           | .000                                  | .000                      | .000                      |
| 23         | 1.580                     | 2.188                    | 1.812                   | 1.525      | 1.457                   | 1.6250-18UNEF                     | 2.062               | 1.634                     | .000                           | .000                                  | .000                      | .000                      |
| 25         | 1.709                     | 2.312                    | 2.000                   | 1.525      | 1.582                   | 1.7500-18UNS                      | 2.188               | 1.759                     | .000                           | .000                                  | .000                      | .000                      |

All dimensions for reference only.

- III 38999
- II
- I
- SJT
- 26482 Matrix 2
- 83723 III Matrix Pyle
- 5015 Crimp Rear Release Matrix
- 26500 Pyle
- Printed Circuit Board
- EMI Filter Transient
- Fiber Optics
- High Speed Contacts
- Options Others

38999  
SJT I II III

26482  
Matrix 2

83723 III  
Matrix Pyle

5015  
Crimp Rear  
Release Matrix

26500 Pyle

Printed  
Circuit Board

EMI Filter  
Transient

Fiber Optics

High Speed  
Contacts

Options  
Others

The Amphenol® FSJT Series combines the unique design features of the scoop-proof FLJT Series with the standard mounting dimensions of JT types.

- 100% scoop-proof design
- Standard mounting dimensions
- Compliance with European Specifications PAN6433-2, LN29729, VG96912
- Uses proven filter technology with available components from other series
- EMP protection versions available



**FSJT Master Key/Keyway Rotation**

| Shell Size | AB Angle of Rotation (Degrees) |    |    |     |     |
|------------|--------------------------------|----|----|-----|-----|
|            | Normal                         | A  | B  | C   | D   |
| 8          | 95                             | –  | –  | –   | –   |
| 10         | 95                             | 81 | 67 | 123 | 109 |
| 12         | 95                             | 75 | 63 | 127 | 115 |
| 14         | 95                             | 74 | 61 | 129 | 116 |
| 16         | 95                             | 77 | 65 | 125 | 113 |
| 18         | 95                             | 77 | 65 | 125 | 113 |
| 20         | 95                             | 77 | 65 | 125 | 113 |
| 22         | 95                             | 80 | 69 | 121 | 110 |
| 24         | 95                             | 80 | 69 | 121 | 110 |

A plug with a given rotation letter will mate with a receptacle with the same rotation letter. The AB angle for a given connector is the same whether it contains pins or sockets. Inserts are not rotated in conjunction with the master key/keyway.

AB angles shown are viewed from the front face of the connector. A receptacle is shown at right. The angles for the plug are exactly the same, except the direction of rotation is opposite of that shown for the receptacle.

**FSJT**

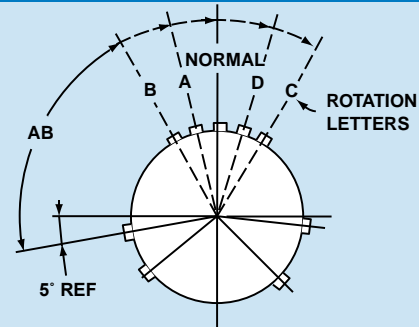

**RELATIVE POSSIBLE POSITION OF ROTATED MASTER KEYWAY (front face of receptacle shown)**

# FSJT – MIL-DTL-38999 Type

## Wall Mounting Receptacle - Aluminum

**PART #** To complete, see how to order pages 288-289.

| Filter Connector Designator | Connector Filter Type | Shell Finish | Shell Style | Shell Size & Insert Arrg | Type of Contact/Keyway Position |
|-----------------------------|-----------------------|--------------|-------------|--------------------------|---------------------------------|
| 21                          | 63                    | X            | 0           | XX-XX                    | X                               |

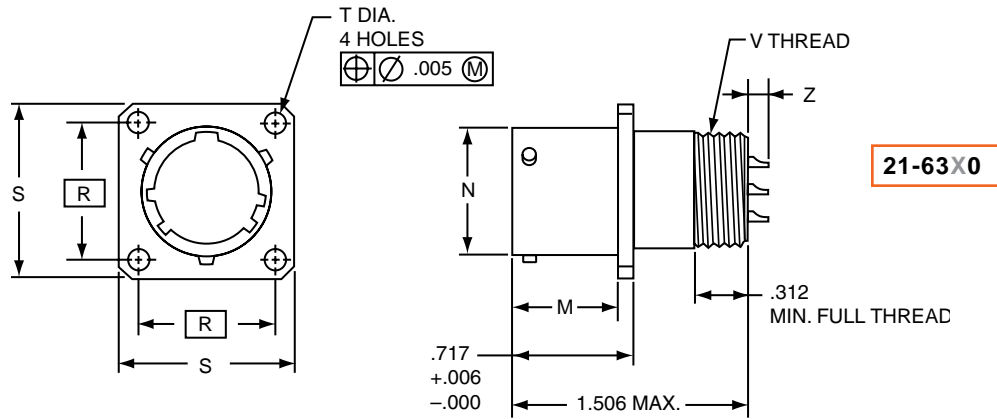

Plug movement required to clear FSJT receptacles: .625 min.

| Shell Size | M<br>+.000<br>-.005 | N Dia.<br>+.001<br>-.005 | R (TP) | S<br>+.021<br>-.020 | T Dia.<br>+.004<br>-.003 | V Thread<br>UNEF-2A | Z Max.          |                             |                 |
|------------|---------------------|--------------------------|--------|---------------------|--------------------------|---------------------|-----------------|-----------------------------|-----------------|
|            |                     |                          |        |                     |                          |                     | Size 20 Contact | Size 16 or 16 & 20 Contacts | Size 22 Contact |
| 10         | .632                | .590                     | .719   | .938                | .120                     | .5625-24            | .165            | .265                        | .134            |
| 12         | .632                | .750                     | .812   | 1.031               | .120                     | .6875-24            | .165            | .265                        | .134            |
| 14         | .632                | .875                     | .906   | 1.125               | .120                     | .8125-20            | .165            | .265                        | .134            |
| 16         | .632                | 1.000                    | .969   | 1.219               | .120                     | .9375-20            | .165            | .265                        | .134            |
| 18         | .632                | 1.125                    | 1.062  | 1.312               | .120                     | 1.0625-18           | .165            | .265                        | .134            |
| 20         | .602                | 1.250                    | 1.156  | 1.438               | .120                     | 1.1875-18           | .165            | .265                        | .134            |
| 22         | .602                | 1.375                    | 1.250  | 1.562               | .120                     | 1.3125-18           | .165            | .265                        | .134            |
| 24         | .602                | 1.500                    | 1.375  | 1.688               | .147                     | 1.4375-18           | .165            | .265                        | .134            |

All dimensions for reference only.

- III 38999
- II Matrix 2
- I 26482
- SJT 83723 III
- Pyle 5015
- Crimp Rear Release Matrix 26500 Pyle
- Printed Circuit Board
- EMI Filter Transient
- Fiber Optics
- High Speed Contacts
- Options Others

### Aluminum

38999  
SJT I II III

26482  
Matrix 2

83723 III  
Matrix Pyle

5015  
Crimp Rear Release Matrix

26500 Pyle

Printed  
Circuit Board

EMI Filter  
Transient

Fiber Optics

High Speed  
Contacts

Options  
Others

#### PART #

To complete, see how to order pages 288-289.

| Filter Connector Designator | Connector Filter Type | Shell Finish | Shell Style | Shell Size & Insert Arrg | Type of Contact/ Keyway Position |
|-----------------------------|-----------------------|--------------|-------------|--------------------------|----------------------------------|
| 21                          | 65                    | X            | 0           | XX-XX                    | X                                |
| 21                          | 63                    | X            | 2           | XX-XX                    | X                                |

#### UTS (Crimp) Contact SAE AS39029/57

#### 21-65X0

#### UTS (Crimp) Contact SAE AS39029/57

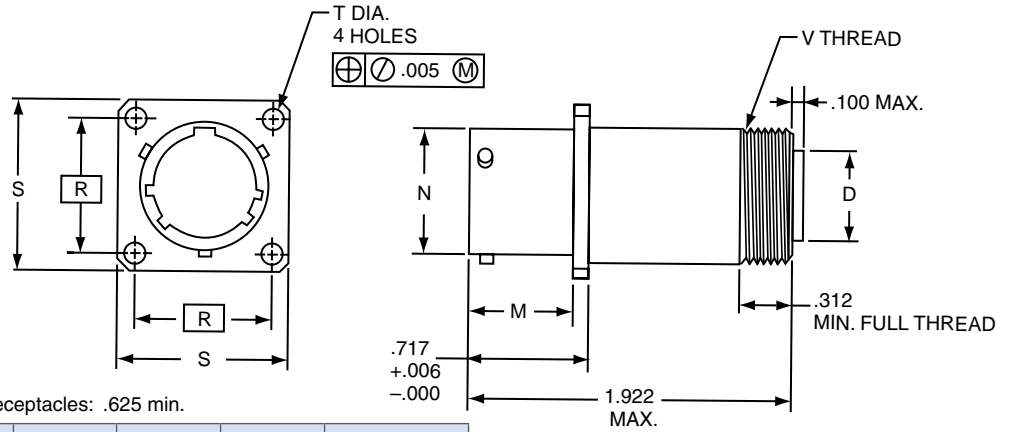

Plug movement required to clear FSJT receptacles: .625 min.

| Shell Size | D Dia. $\pm .005$ | M $+ .000$ $- .005$ | N Dia. $+ .001$ $- .005$ | R (TP) | S $+ .021$ $- .020$ | T Dia. $+ .004$ $- .003$ | V Thread UNEF-2A |
|------------|-------------------|---------------------|--------------------------|--------|---------------------|--------------------------|------------------|
| 10         | .427              | .632                | .590                     | .719   | .938                | .120                     | .6875-24         |
| 12         | .541              | .632                | .750                     | .812   | 1.031               | .120                     | .8125-20         |
| 14         | .666              | .632                | .875                     | .906   | 1.125               | .120                     | .9375-20         |
| 16         | .791              | .632                | 1.000                    | .969   | 1.219               | .120                     | 1.0625-18        |
| 18         | .897              | .632                | 1.125                    | 1.062  | 1.312               | .120                     | 1.1875-18        |
| 20         | 1.022             | .602                | 1.250                    | 1.156  | 1.438               | .120                     | 1.3125-18        |
| 22         | 1.147             | .602                | 1.375                    | 1.250  | 1.562               | .120                     | 1.4375-18        |
| 24         | 1.272             | .602                | 1.500                    | 1.375  | 1.688               | .147                     | 1.5625-18        |

## FSJT MIL-DTL-38999 Type Box Mounting Receptacle Aluminum

#### 21-63X2

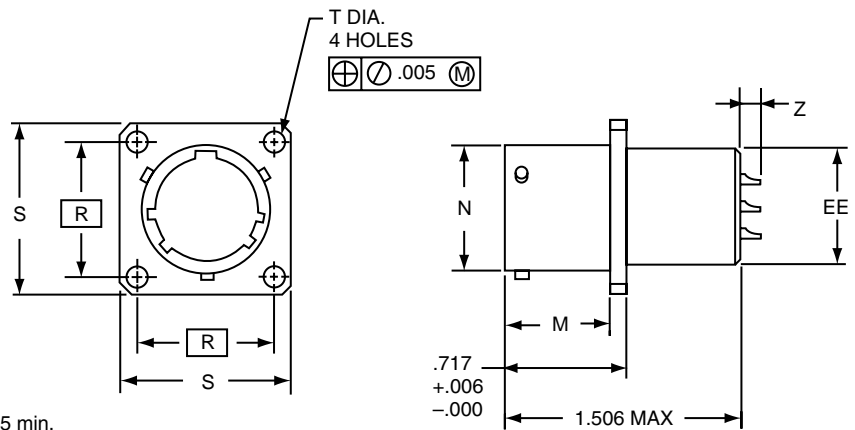

Plug movement required to clear FSJT receptacles: .625 min.

| Shell Size | M $+ .000$ $- .005$ | N Dia. $+ .001$ $- .005$ | R (TP) | S $+ .021$ $- .020$ | T Dia. $+ .004$ $- .003$ | EE $+ .001$ $- .005$ | Z Max.          |                 |                             |                 |
|------------|---------------------|--------------------------|--------|---------------------|--------------------------|----------------------|-----------------|-----------------|-----------------------------|-----------------|
|            |                     |                          |        |                     |                          |                      | Size 16 Contact | Size 20 Contact | Size 16 or 16 & 20 Contacts | Size 22 Contact |
| 10         | .632                | .590                     | .719   | .938                | .120                     | .562                 | .265            | .165            | .265                        | .134            |
| 12         | .632                | .750                     | .812   | 1.031               | .120                     | .687                 | .265            | .165            | .265                        | .134            |
| 14         | .632                | .875                     | .906   | 1.125               | .120                     | .812                 | .265            | .165            | .265                        | .134            |
| 16         | .632                | 1.000                    | .969   | 1.219               | .120                     | .937                 | .265            | .165            | .265                        | .134            |
| 18         | .632                | 1.125                    | 1.062  | 1.312               | .120                     | 1.062                | .265            | .165            | .265                        | .134            |
| 20         | .602                | 1.250                    | 1.156  | 1.438               | .120                     | 1.187                | .265            | .165            | .265                        | .134            |
| 22         | .602                | 1.375                    | 1.250  | 1.562               | .120                     | 1.312                | .265            | .165            | .265                        | .134            |
| 24         | .602                | 1.500                    | 1.375  | 1.688               | .147                     | 1.437                | .265            | .165            | .265                        | .134            |

All dimensions for reference only.



# FSJT – MIL-DTL-38999

## Box Mounting Recpt. (UTS crimp) - Aluminum

**PART #**  
To complete, see how to order pages 288-289.

| Filter Connector Designator | Connector Filter Type | Shell Finish | Shell Style | Shell Size & Insert Arrg | Type of Contact/ Keyway Position |
|-----------------------------|-----------------------|--------------|-------------|--------------------------|----------------------------------|
| 21                          | 65                    | X            | 2           | XX-XX                    | X                                |
| 21                          | 63                    | X            | 7           | XX-XX                    | X                                |

**UTS (Crimp) Contact SAE AS39029/57**

**21-65X2**  
UTS (Crimp) Contact  
SAE AS39029/57

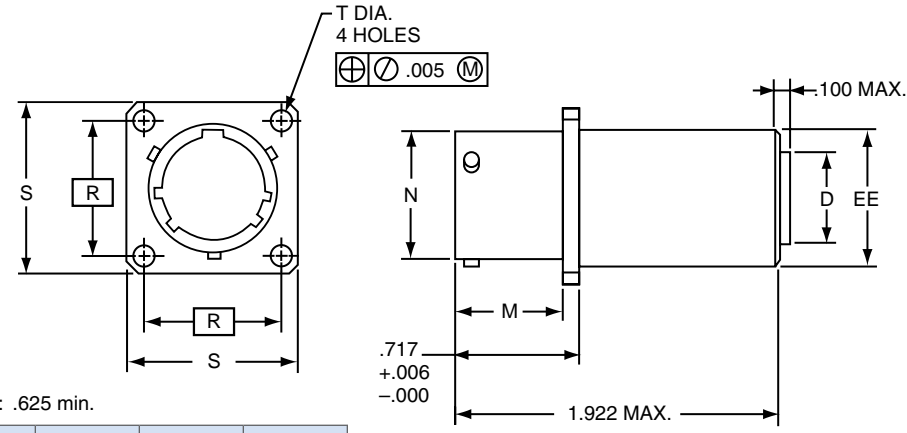

Plug movement required to clear FSJT receptacles: .625 min.

| Shell Size | D Dia. ±.005 | M +.000 - .005 | N Dia. +.001 - .005 | R (TP) | S +.021 - .020 | T Dia. +.004 - .003 | EE Dia. +.001 - .005 |
|------------|--------------|----------------|---------------------|--------|----------------|---------------------|----------------------|
| 10         | .427         | .632           | .590                | .719   | .938           | .120                | .687                 |
| 12         | .541         | .632           | .750                | .812   | 1.031          | .120                | .811                 |
| 14         | .666         | .632           | .875                | .906   | 1.125          | .120                | .937                 |
| 16         | .791         | .632           | 1.000               | .969   | 1.219          | .120                | 1.061                |
| 18         | .897         | .632           | 1.125               | 1.062  | 1.312          | .120                | 1.187                |
| 20         | 1.022        | .602           | 1.250               | 1.156  | 1.438          | .120                | 1.312                |
| 22         | 1.147        | .602           | 1.375               | 1.250  | 1.562          | .120                | 1.437                |
| 24         | 1.272        | .602           | 1.500               | 1.375  | 1.688          | .147                | 1.562                |

# FSJT MIL-DTL-38999

## Jam Nut Receptacle Aluminum

**21-63X7**

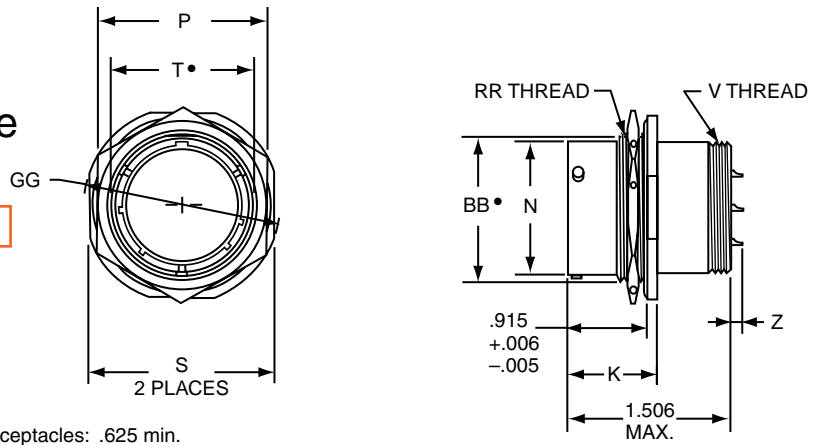

• "D" shaped mounting hole dimensions  
Plug movement required to clear FSJT receptacles: .625 min.

| Shell Size | K +.006 - .005 | N Dia. +.001 - .005 | P Hex | S ±.016 | T* +.010 - .000 | V Thread UNEF Class 2A | Z ±.020 | BB* +.000 - .010 | GG Max. | RR Thread UNEF Class 2A | SS +.001 - .016 |
|------------|----------------|---------------------|-------|---------|-----------------|------------------------|---------|------------------|---------|-------------------------|-----------------|
| 10         | 1.024          | .590                | .875  | 1.062   | .697            | .5625-24               | .150    | .669             | 1.203   | .6875-24                | .680            |
| 12         | 1.024          | .750                | 1.062 | 1.250   | .884            | .6875-24               | .150    | .830             | 1.391   | .8750-20                | .859            |
| 14         | 1.024          | .875                | 1.188 | 1.375   | 1.007           | .8125-20               | .150    | .955             | 1.515   | 1.0000-20               | .984            |
| 16         | 1.024          | 1.000               | 1.312 | 1.500   | 1.134           | .9375-20               | .150    | 1.084            | 1.641   | 1.1250-18               | 1.108           |
| 18         | 1.055          | 1.125               | 1.438 | 1.625   | 1.259           | 1.0625-18              | .150    | 1.208            | 1.766   | 1.2500-18               | 1.233           |
| 20         | 1.055          | 1.250               | 1.562 | 1.812   | 1.384           | 1.1875-18              | .150    | 1.333            | 1.953   | 1.3750-18               | 1.358           |
| 22         | 1.055          | 1.375               | 1.688 | 1.938   | 1.507           | 1.3125-18              | .150    | 1.459            | 2.078   | 1.5000-18               | 1.483           |
| 24         | 1.055          | 1.500               | 1.812 | 2.062   | 1.634           | 1.4375-18              | .150    | 1.580            | 2.203   | 1.6250-18               | 1.610           |

All dimensions for reference only.

- III 38999
- II SJT
- I 26482 Matrix 2
- 83723 III Matrix Pyle
- 5015 Crimp Rear Release Matrix
- 26500 Pyle
- Printed Circuit Board
- EMI Filter Transient
- Fiber Optics
- High Speed Contacts
- Options Others

38999  
SJT I II III

26482  
Matrix 2

83723 III  
Matrix Pyle

5015  
Crimp Rear  
Release Matrix

26500 Pyle

Printed  
Circuit Board

EMI Filter  
Transient

Fiber Optics

High Speed  
Contacts

Options  
Others

Components designed to meet the severe mechanical and environmental requirements of MIL-DTL-38999 Series III are now available to Series IV users. Modifications of the connector are available with EMP protection, incorporating MOV's, diodes or a combination of both.

- Intermateable with MIL-DTL-38999 Series IV plugs
- Maintains all the features of standard MIL-DTL-38999 Series IV receptacles
- Scoop-proof pins provide contact protection
- Uses insert patterns from MIL-DTL-38999 Series III



### FBL Master Key/Keyway Rotation

| Shell Size | Receptacle Key Position |         |         |         | Main Key Receptacle/Basic     |                            |
|------------|-------------------------|---------|---------|---------|-------------------------------|----------------------------|
|            | PP°                     | QQ°     | RR°     | SS°     | Socket Contact T <sub>1</sub> | Pin Contact T <sub>2</sub> |
| 11         | 44°28'                  | 151°6'  | 208°54' | 315°32' | .075                          | .109                       |
| 13         | 44°25'                  | 150°31' | 209°29' | 315°35' | .076                          | .112                       |
| 15         | 44°33'                  | 150°24' | 209°36' | 315°27' | .096                          | .132                       |
| 17         | 44°36'                  | 150°22' | 209°38' | 315°24' | .096                          | .134                       |
| 19         | 44°33'                  | 150°27' | 209°33' | 315°27' | .117                          | .154                       |
| 21         | 44°34'                  | 150°23' | 209°37' | 315°26' | .118                          | .155                       |
| 23         | 44°34'                  | 150°20' | 209°40' | 315°26' | .138                          | .176                       |
| 25         | 44°42'                  | 150°22' | 209°48' | 315°18' | .139                          | .177                       |

## FBL

### Polarity Dimensions

| Key and Keyway Arrangement | XX°  | YY°  |
|----------------------------|------|------|
| N                          | 110° | 250° |
| A                          | 100° | 260° |
| B                          | 90°  | 270° |
| C                          | 80°  | 280° |
| D                          | 70°  | 290° |
| K                          | 120° | 255° |

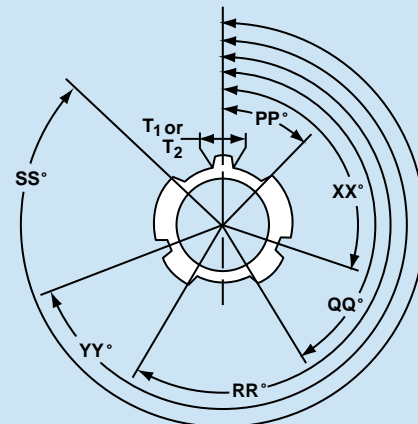

RELATIVE POSSIBLE POSITION OF KEYWAYS  
(front face of receptacle shown)

# FBL – MIL-DTL-38999, Series IV

## Box and Wall Mounting Receptacle

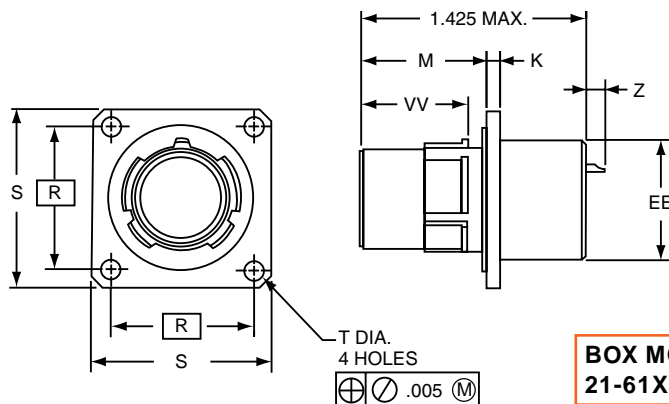

**BOX MOUNT**  
21-61X2XX-XXX

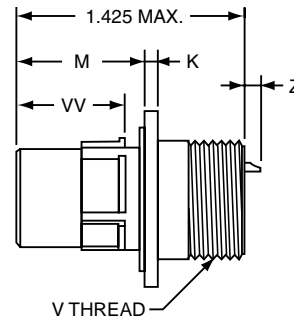

**WALL MOUNT**  
21-61X0XX-XXX

| Shell Size | K<br>±.010 | M<br>±.020 | R<br>(TP) | S<br>+.021<br>-.020 | T Dia.<br>+.004<br>-.003 | V Thread<br>(Plated)<br>-.006 | EE Dia.<br>+.001<br>-.005 | VV<br>±.003 | Z Max.          |                 |                             |                 |
|------------|------------|------------|-----------|---------------------|--------------------------|-------------------------------|---------------------------|-------------|-----------------|-----------------|-----------------------------|-----------------|
|            |            |            |           |                     |                          |                               |                           |             | Size 16 Contact | Size 20 Contact | Size 16 or 16 & 20 Contacts | Size 22 Contact |
| 11         | .092       | .791       | .812      | 1.029               | .128                     | M15X1-6g0.100R                | .589                      | .672        | .265            | .165            | .265                        | .134            |
| 13         | .092       | .791       | .906      | 1.124               | .128                     | M18X1-6g0.100R                | .707                      | .672        | .265            | .165            | .265                        | .134            |
| 15         | .092       | .791       | .969      | 1.218               | .128                     | M22X1-6g0.100R                | .865                      | .672        | .265            | .165            | .265                        | .134            |
| 17         | .092       | .791       | 1.062     | 1.313               | .128                     | M25X1-6g0.100R                | .983                      | .672        | .265            | .165            | .265                        | .134            |
| 19         | .092       | .791       | 1.156     | 1.439               | .128                     | M28X1-6g0.100R                | 1.101                     | .662        | .265            | .165            | .265                        | .134            |
| 21         | .124       | .791       | 1.250     | 1.561               | .128                     | M31X1-6g0.100R                | 1.219                     | .662        | .265            | .165            | .265                        | .134            |
| 23         | .124       | .791       | 1.375     | 1.687               | .147                     | M34X1-6g0.100R                | 1.337                     | .662        | .265            | .165            | .265                        | .134            |
| 25         | .124       | .791       | 1.500     | 1.813               | .147                     | M37X1-6g0.100R                | 1.455                     | .662        | .265            | .165            | .265                        | .134            |

All dimensions for reference only.

# FBL – MIL-DTL-38999 Series IV

## Box and Wall Mounting Receptacle (UTS Crimp)

**PART #** To complete, see how to order pages 288-289.

| Filter Connector Designator | Connector Filter Type | Shell Finish | Shell Style | Shell Size & Insert Arrg | Type of Contact/Keyway Position |
|-----------------------------|-----------------------|--------------|-------------|--------------------------|---------------------------------|
| 21                          | 64                    | X            | 2           | XX-XX                    | X                               |

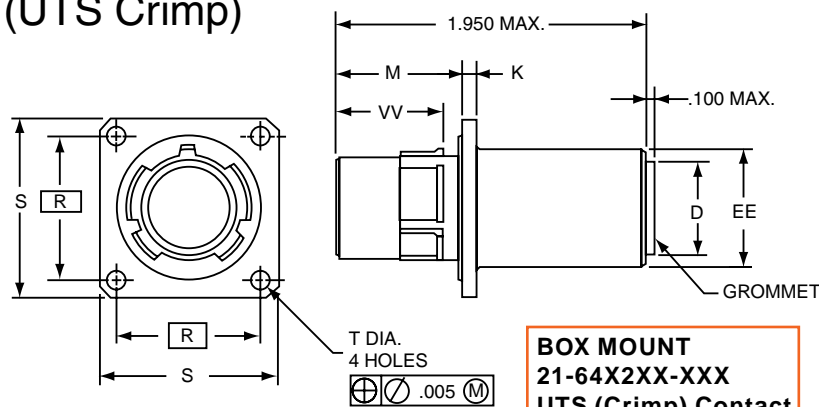

**BOX MOUNT**  
21-64X2XX-XXX  
UTS (Crimp) Contact  
MIL-C-39029/57

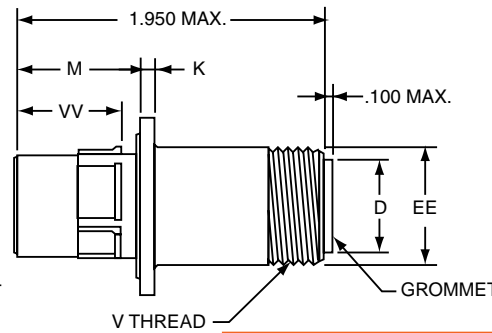

**WALL MOUNT**  
21-64X0XX-XXX  
UTS (Crimp) Contact  
MIL-C-39029/57

| Shell Size | D Dia.<br>±.005 | K<br>±.010 | M<br>±.020 | R<br>(TP) | S<br>+.021<br>-.020 | T Dia.<br>+.004<br>-.003 | V Thread<br>(Plated)<br>-.006 | EE Dia.<br>+.001<br>-.005 | VV<br>±.003 |
|------------|-----------------|------------|------------|-----------|---------------------|--------------------------|-------------------------------|---------------------------|-------------|
| 11         | .427            | .092       | .791       | .812      | 1.029               | .128                     | M18X1-6g0.100R                | .687                      | .672        |
| 13         | .541            | .092       | .791       | .906      | 1.124               | .128                     | M22X1-6g0.100R                | .811                      | .672        |
| 15         | .666            | .092       | .791       | .969      | 1.218               | .128                     | M25X1-6g0.100R                | .937                      | .672        |
| 17         | .791            | .092       | .791       | 1.062     | 1.313               | .128                     | M28X1-6g0.100R                | 1.061                     | .672        |
| 19         | .897            | .092       | .791       | 1.156     | 1.439               | .128                     | M31X1-6g0.100R                | 1.187                     | .662        |
| 21         | 1.022           | .124       | .791       | 1.250     | 1.561               | .128                     | M34X1-6g0.100R                | 1.312                     | .662        |
| 23         | 1.147           | .124       | .791       | 1.375     | 1.687               | .147                     | M37X1-6g0.100R                | 1.437                     | .662        |
| 25         | 1.272           | .124       | .791       | 1.500     | 1.813               | .147                     | M41X1-6g0.100R                | 1.562                     | .662        |

- III 38999
- II SJT
- I Matrix 2
- 26482
- 83723 III
- Matrix Pyle
- 5015
- Crimp Rear Release Matrix
- 26500 Pyle
- Printed Circuit Board
- EMI Filter Transient
- Fiber Optics
- High Speed Contacts
- Options Others

The Amphenol® FPT Series combines the unique design features of the miniature PT Series with an EMI filter.

- Intermateable with MIL-DTL-26482 Series connectors see Matrix 26482, series 2 section in this catalog or Catalog 12-070 for MIL-DTL-26482, Series 1.
- Quick positive coupling with visual confirmation of mating
- Higher reliability and greater durability with permanently encapsulated contacts
- Aluminum shells with several finish options



**FPT Series Connectors**

FPT Alternate Positions

| Insert Arrangements | Degrees |     |     |     |
|---------------------|---------|-----|-----|-----|
|                     | W       | X   | Y   | Z   |
| 10-5                | 45      | 151 | 180 | 270 |
| 10-6                | 90      | –   | –   | –   |
| 10-98               | 90      | 180 | 240 | 270 |
| 12-3                | –       | –   | 180 | –   |
| 12-8                | 90      | 112 | 203 | 292 |
| 12-10               | 60      | 155 | 270 | 295 |
| 12-98               | 61      | 135 | 189 | 340 |
| 14-12               | 434     | 90  | –   | –   |
| 14-18               | 15      | 90  | 180 | 270 |
| 14-19               | 30      | 165 | 315 | –   |
| 16-8                | 54      | 152 | 180 | 331 |
| 16-26               | 60      | –   | 275 | 338 |
| 18-32               | 85      | 138 | 222 | 265 |
| 20-41               | 45      | 126 | 225 | –   |
| 22-41               | 39      | –   | –   | –   |
| 22-55               | 30      | 142 | 226 | 314 |
| 24-61               | 90      | 180 | 270 | 324 |

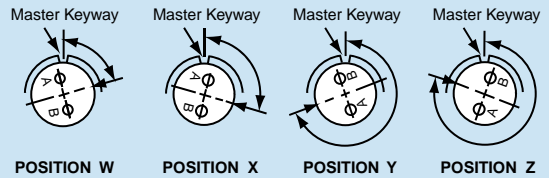

Views looking into front face of pin insert or rear of socket insert.

38999  
SJT I II III

26482  
Matrix 2

83723 III  
Matrix Pyle

5015  
Crimp Rear Release Matrix

26500 Pyle

Printed  
Circuit Board

EMI Filter  
Transient

Fiber Optics

High Speed  
Contacts

Options  
Others

# FPT - MIL-DTL-26482 Wall Mounting Receptacle

### PART #

To complete, see how to order pages 288-289.

| Filter Connector Designator | Connector Filter Type | Shell Finish | Shell Style | Shell Size & Insert Arrg | Type of Contact/Keyway Position |
|-----------------------------|-----------------------|--------------|-------------|--------------------------|---------------------------------|
| 21                          | 20                    | X            | 0           | XX-XX                    | X                               |
| 21                          | 31                    | X            | 0           | XX-XX                    | X                               |
| 21                          | 33                    | X            | 0           | XX-XX                    | X                               |

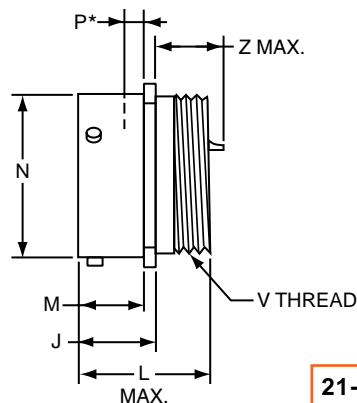
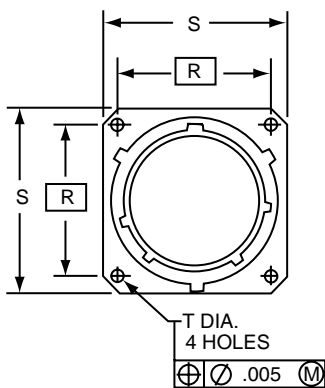

21-20X0XX-XXX  
21-31X0XX-XXX

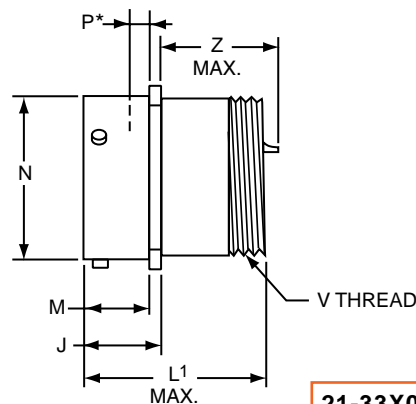

21-33X0XX-XXX

Plug movement required to clear FPT receptacles: .438 min.  
\* Acceptable panel thickness for back panel mounting a standard receptacle.

| Shell Size | J<br>+.021<br>-.010 | M<br>+.010<br>-.000 | N Dia<br>+.001<br>-.005 | P*<br>Max. | R<br>(TP) | S<br>+.011<br>-.010 | T<br>Dia.<br>±.005 | V<br>Thread<br>UNEF-2A<br>(Plated) | SHORT SHELL<br>VHF/UHF/MF Filters |                              |   | LONG SHELL<br>HF Filters |                              |   |
|------------|---------------------|---------------------|-------------------------|------------|-----------|---------------------|--------------------|------------------------------------|-----------------------------------|------------------------------|---|--------------------------|------------------------------|---|
|            |                     |                     |                         |            |           |                     |                    |                                    | L<br>Max.                         | Size 20<br>Contact<br>Z Max. | Size 16 or<br>16 & 20<br>Contacts<br>Z Max. | L1<br>Max.               | Size 20<br>Contact<br>Z Max. | Size 16 or<br>16 & 20<br>Contacts<br>Z Max. |
| 8          | .493                | .431                | .473                    | .087       | .594      | .812                | .120               | .4375-28                           | 1.103                             | .850                         | .904  | 1.588                    | 1.258                        | 1.328                                       |
| 10         | .493                | .431                | .590                    | .087       | .719      | .938                | .120               | .5625-24                           | 1.103                             | .850                         | .904  | 1.588                    | 1.258                        | 1.328                                       |
| 12         | .493                | .431                | .750                    | .087       | .812      | 1.031               | .120               | .6875-24                           | 1.103                             | .850                         | .904  | 1.588                    | 1.258                        | 1.328                                       |
| 14         | .493                | .431                | .875                    | .087       | .906      | 1.125               | .120               | .8125-20                           | 1.103                             | .850                         | .904  | 1.588                    | 1.258                        | 1.328                                       |
| 16         | .493                | .431                | 1.000                   | .087       | .969      | 1.219               | .120               | .9375-20                           | 1.103                             | .850                         | .904  | 1.588                    | 1.258                        | 1.328                                       |
| 18         | .493                | .431                | 1.125                   | .087       | 1.062     | 1.312               | .120               | 1.0625-18                          | 1.103                             | .850                         | .904  | 1.588                    | 1.258                        | 1.328                                       |
| 20         | .650                | .556                | 1.250                   | .212       | 1.156     | 1.438               | .120               | 1.1875-18                          | 1.166                             | .755                         | .809  | 1.651                    | 1.163                        | 1.233                                       |
| 22         | .650                | .556                | 1.375                   | .212       | 1.250     | 1.562               | .120               | 1.3125-18                          | 1.166                             | .755                         | .809  | 1.651                    | 1.163                        | 1.233                                       |
| 24         | .683                | .589                | 1.500                   | .212       | 1.375     | 1.688               | .147               | 1.4375-18                          | 1.166                             | .722                         | .776  | 1.651                    | 1.130                        | 1.200                                       |

All dimensions for reference only.

- III 38999
- II
- I
- SJT
- 26482 Matrix 2
- 83723 III Matrix Pyle
- 5015 Crimp Rear Release Matrix
- 26500 Pyle
- Printed Circuit Board
- EMI Filter Transient
- Fiber Optics
- High Speed Contacts
- Options Others

38999  
SJT I II III

26482  
Matrix 2

83723 III  
Matrix Pyle

5015  
Crimp Rear  
Release Matrix

26500 Pyle

Printed  
Circuit Board

EMI Filter  
Transient

Fiber Optics

High Speed  
Contacts

Options  
Others

### PART #

To complete, see how to order pages 288-289.

| Filter Connector Designator | Connector Filter Type | Shell Finish | Shell Style | Shell Size & Insert Arrg | Type of Contact/ Keyway Position |
|-----------------------------|-----------------------|--------------|-------------|--------------------------|----------------------------------|
| 21                          | 20                    | X            | 2           | XX-XX                    | X                                |
| 21                          | 31                    | X            | 2           | XX-XX                    | X                                |
| 21                          | 33                    | X            | 2           | XX-XX                    | X                                |

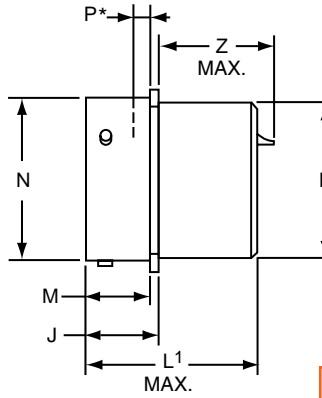
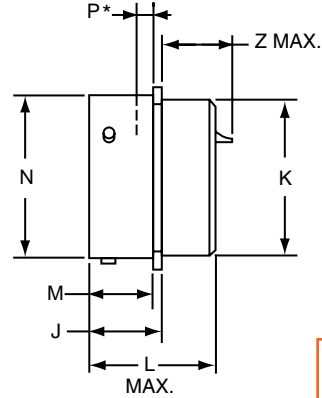
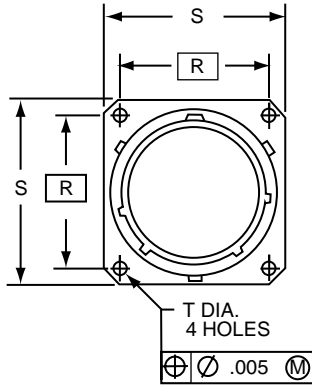

Plug movement required to clear FPT receptacles: .438 min.  
\* Acceptable panel thickness for back panel mounting a standard receptacle.

| Shell Size | J<br>+.021<br>-.010 | K<br>Dia.<br>+.011<br>-.000 | M<br>+.010<br>-.000 | N<br>Dia<br>+.001<br>-.005 | P*<br>Max. | R<br>(TP) | S<br>+.011<br>-.010 | T<br>Dia.<br>±.005 | SHORT SHELL<br>VHF/UHF/MF Filters |                              |   | LONG SHELL<br>HF Filters |                              |   |
|------------|---------------------|-----------------------------|---------------------|----------------------------|------------|-----------|---------------------|--------------------|-----------------------------------|------------------------------|---|--------------------------|------------------------------|---|
|            |                     |                             |                     |                            |            |           |                     |                    | L<br>Max.                         | Size 20<br>Contact<br>Z Max. | Size 16 or<br>16 & 20<br>Contacts<br>Z Max. | L <sup>1</sup><br>Max.   | Size 20<br>Contact<br>Z Max. | Size 16 or<br>16 & 20<br>Contacts<br>Z Max. |
| 8          | .493                | .438                        | .431                | .473                       | .087       | .594      | .812                | .120               | 1.103                             | .850                         | .904  | 1.588                    | 1.258                        | 1.328                                       |
| 10         | .493                | .562                        | .431                | .590                       | .087       | .719      | .938                | .120               | 1.103                             | .850                         | .904  | 1.588                    | 1.258                        | 1.328                                       |
| 12         | .493                | .688                        | .431                | .750                       | .087       | .812      | 1.031               | .120               | 1.103                             | .850                         | .904  | 1.588                    | 1.258                        | 1.328                                       |
| 14         | .493                | .812                        | .431                | .875                       | .087       | .906      | 1.125               | .120               | 1.103                             | .850                         | .904  | 1.588                    | 1.258                        | 1.328                                       |
| 16         | .493                | .938                        | .431                | 1.000                      | .087       | .969      | 1.219               | .120               | 1.103                             | .850                         | .904  | 1.588                    | 1.258                        | 1.328                                       |
| 18         | .493                | 1.062                       | .431                | 1.125                      | .087       | 1.062     | 1.312               | .120               | 1.103                             | .850                         | .904  | 1.588                    | 1.258                        | 1.328                                       |
| 20         | .650                | 1.188                       | .556                | 1.250                      | .212       | 1.156     | 1.438               | .120               | 1.166                             | .755                         | .809  | 1.651                    | 1.163                        | 1.233                                       |
| 22         | .650                | 1.312                       | .556                | 1.375                      | .212       | 1.250     | 1.562               | .120               | 1.166                             | .755                         | .809  | 1.651                    | 1.163                        | 1.233                                       |
| 24         | .683                | 1.438                       | .589                | 1.500                      | .212       | 1.375     | 1.688               | .147               | 1.166                             | .722                         | .776  | 1.651                    | 1.130                        | 1.200                                       |

All dimensions for reference only.



### PART #

To complete, see how to order pages 288-289.

| Filter Connector Designator | Connector Filter Type | Shell Finish | Shell Style | Shell Size & Insert Arrg | Type of Contact/ Keyway Position |
|-----------------------------|-----------------------|--------------|-------------|--------------------------|----------------------------------|
| 21                          | 20                    | X            | 7           | XX-XX                    | X                                |
| 21                          | 31                    | X            | 7           | XX-XX                    | X                                |
| 21                          | 33                    | X            | 7           | XX-XX                    | X                                |

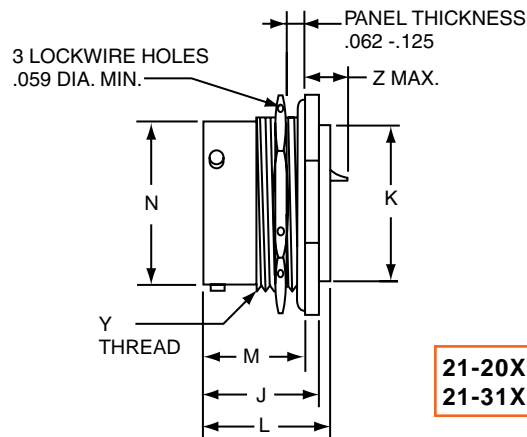
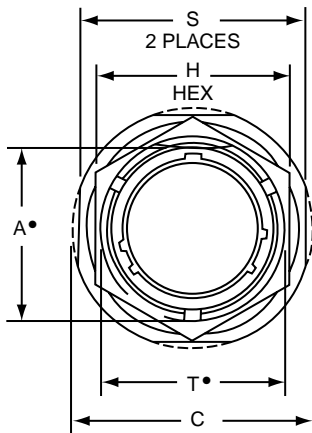

**21-20X7XX-XXX**  
**21-31X7XX-XXX**

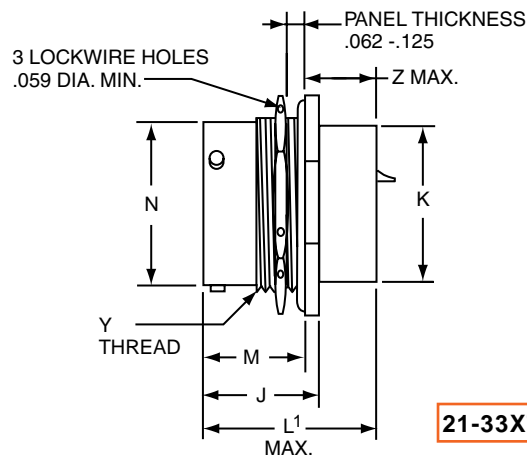

**21-33X7XX-XXX**

• "D" shaped mounting hole dimensions  
Plug movement required to clear FPT receptacles: .438 min.

| Shell Size | A* Flat<br>+0.000<br>-0.010 | C Dia.<br>+0.011<br>-0.010 | H Hex<br>+0.017<br>-0.016 | J<br>+0.006<br>-0.005 | K Dia.<br>+0.011<br>-0.000 | M<br>±0.005 | N Dia<br>+0.001<br>-0.005 | S<br>±0.010 | T* Dia.<br>+0.010<br>-0.000 | Y Thread<br>UNEF-2A<br>(Plated) | SHORT SHELL<br>VHF/UHF/MF Filters |                           |                                       | LONG SHELL<br>HF Filters |                           |                                       |
|------------|-----------------------------|----------------------------|---------------------------|-----------------------|----------------------------|-------------|---------------------------|-------------|-----------------------------|---------------------------------|-----------------------------------|---------------------------|---------------------------------------|--------------------------|---------------------------|---------------------------------------|
|            |                             |                            |                           |                       |                            |             |                           |             |                             |                                 | L Max.                            | Size 20 Contact<br>Z Max. | Size 16 or 16 & 20 Contacts<br>Z Max. | L' Max.                  | Size 20 Contact<br>Z Max. | Size 16 or 16 & 20 Contacts<br>Z Max. |
| 8          | .542                        | 1.062                      | .750                      | .821                  | .438                       | .696        | .473                      | .938        | .572                        | .5625-24                        | 1.103                             | .642                      | .698                                  | 1.588                    | 1.050                     | 1.120                                 |
| 10         | .669                        | 1.188                      | .875                      | .821                  | .562                       | .696        | .590                      | 1.062       | .697                        | .6875-24                        | 1.103                             | .642                      | .698                                  | 1.588                    | 1.050                     | 1.120                                 |
| 12         | .830                        | 1.375                      | 1.062                     | .821                  | .688                       | .696        | .750                      | 1.250       | .884                        | .8750-20                        | 1.103                             | .642                      | .698                                  | 1.588                    | 1.050                     | 1.120                                 |
| 14         | .955                        | 1.500                      | 1.188                     | .821                  | .812                       | .696        | .875                      | 1.375       | 1.009                       | 1.0000-20                       | 1.103                             | .642                      | .698                                  | 1.588                    | 1.050                     | 1.120                                 |
| 16         | 1.084                       | 1.625                      | 1.312                     | .821                  | .938                       | .696        | 1.000                     | 1.500       | 1.134                       | 1.1250-18                       | 1.103                             | .642                      | .698                                  | 1.588                    | 1.050                     | 1.120                                 |
| 18         | 1.208                       | 1.750                      | 1.438                     | .821                  | 1.062                      | .696        | 1.125                     | 1.625       | 1.259                       | 1.2500-18                       | 1.103                             | .642                      | .698                                  | 1.588                    | 1.050                     | 1.120                                 |
| 20         | 1.333                       | 1.938                      | 1.562                     | 1.040                 | 1.188                      | .884        | 1.250                     | 1.812       | 1.384                       | 1.3750-18                       | 1.166                             | .516                      | .570                                  | 1.651                    | .924                      | .994                                  |
| 22         | 1.459                       | 2.062                      | 1.688                     | 1.040                 | 1.312                      | .884        | 1.375                     | 1.938       | 1.509                       | 1.5000-18                       | 1.166                             | .516                      | .570                                  | 1.651                    | .924                      | .994                                  |
| 24         | 1.575                       | 2.188                      | 1.812                     | 1.073                 | 1.438                      | .917        | 1.500                     | 2.062       | 1.634                       | 1.6250-18                       | 1.166                             | .483                      | .537                                  | 1.651                    | .891                      | .961                                  |

All dimensions for reference only.

38999  
SJT

26482  
Matrix 2

83723 III  
Pyle

5015  
Crimp Rear Release Matrix

26500 Pyle

Printed  
Circuit Board

EMI Filter  
Transient

Fiber Optics

High Speed  
Contacts

Options  
Others

38999  
SJT I II III

26482  
Matrix 2

83723 III  
Matrix Pyle

5015  
Crimp Rear Release Matrix

26500 Pyle

Printed  
Circuit Board

EMI Filter  
Transient

Fiber Optics

High Speed  
Contacts

Options  
Others

### PART #

To complete, see how to order pages 288-289.

| Filter Connector Designator | Connector Filter Type | Shell Finish | Shell Style | Shell Size & Insert Arrg | Type of Contact/ Keyway Position |
|-----------------------------|-----------------------|--------------|-------------|--------------------------|----------------------------------|
| 21                          | 20                    | X            | 4           | XX-XX                    | X                                |
| 21                          | 31                    | X            | 4           | XX-XX                    | X                                |
| 21                          | 33                    | X            | 4           | XX-XX                    | X                                |

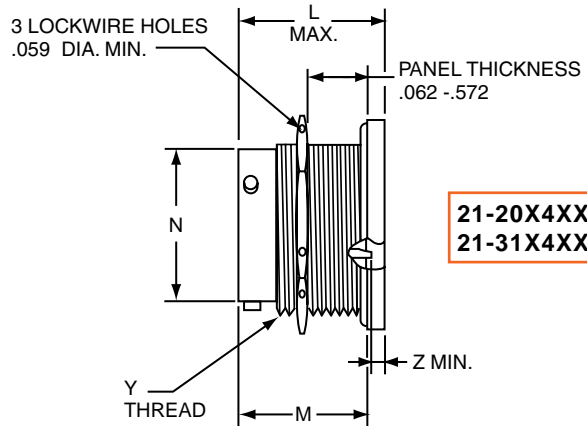
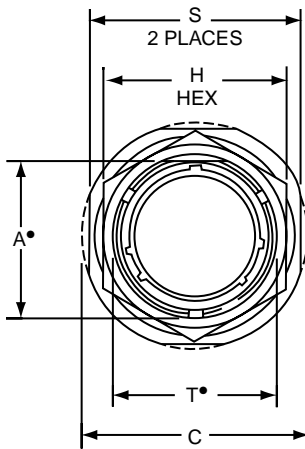

**21-20X4XX-XXX**  
**21-31X4XX-XXX**

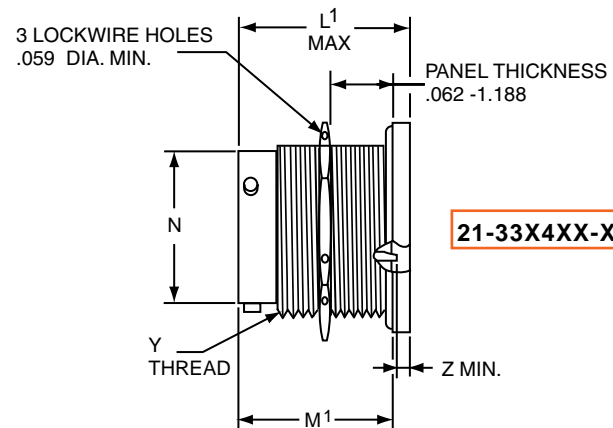

**21-33X4XX-XXX**

• "D" shaped mounting hole dimensions  
Plug movement required to clear FPT receptacles: .438 min.

| Shell Size | A* Flat<br>+0.000<br>-0.010 | C Dia.<br>+0.011<br>-0.010 | H Hex<br>+0.017<br>-0.016 | M<br>+0.016<br>-0.015 | M'<br>+0.016<br>-0.015 | N Dia<br>+0.001<br>-0.005 | S<br>+0.011<br>-0.010 | T* Dia.<br>+0.010<br>-0.000 | Y Thread<br>UNE-F-2A<br>(Plated) | SHORT SHELL<br>VHF/UHF/MF Filters |                           |                                       | LONG SHELL<br>HF Filters |                           |                                       |
|------------|-----------------------------|----------------------------|---------------------------|-----------------------|------------------------|---------------------------|-----------------------|-----------------------------|----------------------------------|-----------------------------------|---------------------------|---------------------------------------|--------------------------|---------------------------|---------------------------------------|
|            |                             |                            |                           |                       |                        |                           |                       |                             |                                  | L Max.                            | Size 20 Contact<br>Z Max. | Size 16 or 16 & 20 Contacts<br>Z Max. | L' Max.                  | Size 20 Contact<br>Z Max. | Size 16 or 16 & 20 Contacts<br>Z Max. |
| 8          | .542                        | 1.062                      | .750                      | 1.235                 | 1.690                  | .473                      | .938                  | .572                        | .5625-24                         | 1.366                             | .022                      | .029                                  | 1.821                    | .070                      | .000                                  |
| 10         | .669                        | 1.188                      | .875                      | 1.235                 | 1.690                  | .590                      | 1.062                 | .697                        | .6875-24                         | 1.366                             | .022                      | .029                                  | 1.821                    | .070                      | .000                                  |
| 12         | .830                        | 1.375                      | 1.062                     | 1.235                 | 1.690                  | .750                      | 1.250                 | .884                        | .8750-20                         | 1.366                             | .022                      | .029                                  | 1.821                    | .070                      | .000                                  |
| 14         | .955                        | 1.500                      | 1.188                     | 1.235                 | 1.690                  | .875                      | 1.375                 | 1.009                       | 1.0000-20                        | 1.366                             | .022                      | .029                                  | 1.821                    | .070                      | .000                                  |
| 16         | 1.084                       | 1.625                      | 1.312                     | 1.235                 | 1.690                  | 1.000                     | 1.500                 | 1.134                       | 1.1250-18                        | 1.366                             | .022                      | .029                                  | 1.821                    | .070                      | .000                                  |
| 18         | 1.208                       | 1.750                      | 1.438                     | 1.235                 | 1.690                  | 1.125                     | 1.625                 | 1.259                       | 1.2500-18                        | 1.366                             | .022                      | .029                                  | 1.821                    | .070                      | .000                                  |
| 20         | 1.333                       | 1.938                      | 1.562                     | 1.266                 | 1.721                  | 1.250                     | 1.812                 | 1.384                       | 1.3750-18                        | 1.428                             | .062                      | .029                                  | 1.883                    | .070                      | .000                                  |
| 22         | 1.459                       | 2.062                      | 1.688                     | 1.266                 | 1.721                  | 1.375                     | 1.938                 | 1.509                       | 1.5000-18                        | 1.428                             | .062                      | .029                                  | 1.883                    | .070                      | .000                                  |
| 24         | 1.575                       | 2.188                      | 1.812                     | 1.266                 | 1.721                  | 1.500                     | 2.062                 | 1.634                       | 1.6250-18                        | 1.428                             | .062                      | .029                                  | 1.883                    | .070                      | .000                                  |

All dimensions for reference only.

# FPTE Wall Mounting Receptacle

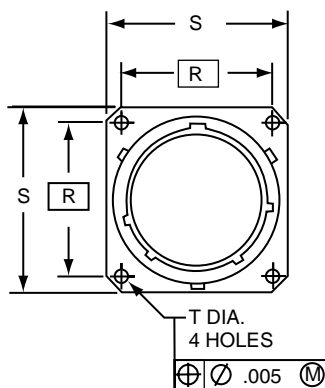

| PART #                                       | Filter Connector Designator | Connector Filter Type | Shell Finish | Shell Style | Shell Size & Insert Arrg | Type of Contact/Keyway Position |
|--|-----------------------------|-----------------------|--------------|-------------|--------------------------|---------------------------------|
| To complete, see how to order pages 288-289. | 21                          | 22                    | X            | 0           | XX-XX                    | X                               |
|  | 21                          | 32                    | X            | 7           | XX-XX                    | X                               |

**21-22X0XX-XXX**

Plug movement required to clear FPT receptacles: .438 min.  
\* Acceptable panel thickness for back panel mounting a standard receptacle.

| Shell Size | J<br>+.021<br>-.010 | M<br>+.010<br>-.000 | N<br>Dia<br>+.001<br>-.005 | P*<br>Max. | R<br>(TP) | S<br>+.011<br>-.010 | T<br>Dia.<br>±.005 | SHORT SHELL<br>VHF/UHF/MF Filters |                              |
|------------|---------------------|---------------------|----------------------------|------------|-----------|---------------------|--------------------|-----------------------------------|------------------------------|
|            |                     |                     |                            |            |           |                     |                    | L<br>Max.                         | Size 20<br>Contact<br>Z Max. |
| 8          | .493                | .431                | .473                       | .087       | .594      | .812                | .120               | 1.409                             | .774                         |
| 10         | .493                | .431                | .590                       | .087       | .719      | .938                | .120               | 1.409                             | .774                         |
| 12         | .493                | .431                | .750                       | .087       | .812      | 1.031               | .120               | 1.409                             | .774                         |
| 14         | .493                | .431                | .875                       | .087       | .906      | 1.125               | .120               | 1.409                             | .774                         |
| 16         | .493                | .431                | 1.000                      | .087       | .969      | 1.219               | .120               | 1.409                             | .774                         |
| 18         | .493                | .431                | 1.125                      | .087       | 1.062     | 1.312               | .120               | 1.409                             | .774                         |
| 20         | .650                | .556                | 1.250                      | .212       | 1.156     | 1.438               | .120               | 1.553                             | .679                         |
| 22         | .650                | .556                | 1.375                      | .212       | 1.250     | 1.562               | .120               | 1.553                             | .679                         |
| 24         | .683                | .589                | 1.500                      | .212       | 1.375     | 1.688               | .147               | 1.553                             | .646                         |

All dimensions for reference only.

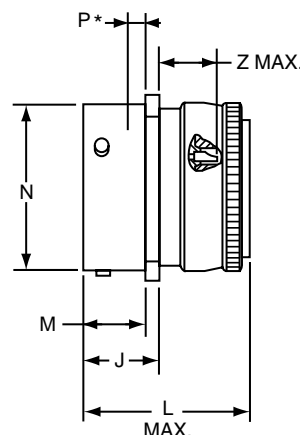

# FPTE Jam Nut Receptacle

**21-22X7XX-XXX**

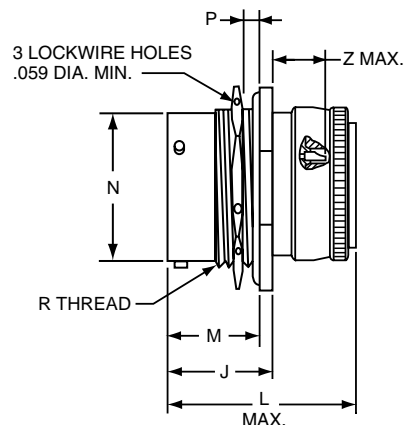
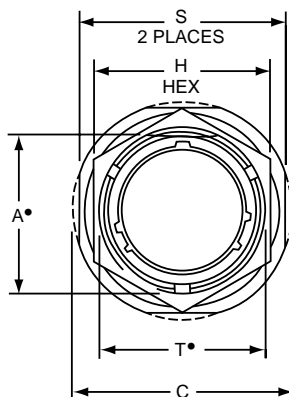

• "D" shaped mounting hole dimensions  
Plug movement required to clear FPT receptacles: .438 min.

| Shell Size | A*<br>Flat<br>+.000<br>-.010 | C<br>Dia.<br>+.011<br>-.010 | H<br>Hex<br>+.017<br>-.016 | J<br>+.006<br>-.005 | M<br>±.005 | N<br>Dia.<br>+.001<br>-.005 | P<br>Panel Thickness |      | R<br>Thread<br>UNEF-2A<br>(Plated) | S<br>±.010 | T*<br>Dia.<br>+.010<br>-.000 | SHORT SHELL<br>VHF/UHF Filters |                              |
|------------|------------------------------|-----------------------------|----------------------------|---------------------|------------|-----------------------------|----------------------|------|------------------------------------|------------|------------------------------|--------------------------------|------------------------------|
|            |                              |                             |                            |                     |            |                             | Max.                 | Min. |                                    |            |                              | L<br>Max.                      | Size 20<br>Contact<br>Z Max. |
| 8          | .542                         | 1.062                       | .750                       | .821                | .696       | .473                        | .125                 | .062 | .5625-24                           | .938       | .572                         | 1.546                          | .566                         |
| 10         | .669                         | 1.188                       | .875                       | .821                | .696       | .590                        | .125                 | .062 | .6875-24                           | 1.062      | .697                         | 1.546                          | .566                         |
| 12         | .830                         | 1.375                       | 1.062                      | .821                | .696       | .750                        | .125                 | .062 | .8750-20                           | 1.250      | .884                         | 1.546                          | .566                         |
| 14         | .955                         | 1.500                       | 1.188                      | .821                | .696       | .875                        | .125                 | .062 | 1.0000-20                          | 1.375      | 1.009                        | 1.546                          | .566                         |
| 16         | 1.084                        | 1.625                       | 1.312                      | .821                | .696       | 1.000                       | .125                 | .062 | 1.1250-18                          | 1.500      | 1.134                        | 1.546                          | .566                         |
| 18         | 1.208                        | 1.750                       | 1.438                      | .821                | .696       | 1.125                       | .125                 | .062 | 1.2500-18                          | 1.625      | 1.259                        | 1.546                          | .566                         |
| 20         | 1.333                        | 1.938                       | 1.562                      | 1.040               | .884       | 1.250                       | .250                 | .062 | 1.3750-18                          | 1.812      | 1.384                        | 1.672                          | .440                         |
| 22         | 1.459                        | 2.062                       | 1.688                      | 1.040               | .884       | 1.375                       | .250                 | .062 | 1.5000-18                          | 1.938      | 1.509                        | 1.672                          | .440                         |
| 24         | 1.575                        | 2.188                       | 1.812                      | 1.073               | .917       | 1.500                       | .250                 | .062 | 1.6250-18                          | 2.062      | 1.634                        | 1.672                          | .407                         |

All dimensions for reference only.

III  
II  
I  
SJT  
38999

Matrix 2  
26482

Matrix  
Pyle  
83723 III

Release Matrix  
Crimp Rear  
5015

26500 Pyle

Printed  
Circuit Board

EMI Filter  
Transient

Fiber Optics

High Speed  
Contacts

Options  
Others

The "AN" Filter Connector is designed in configurations intermateable and intermountable with MIL-DTL-5015\* connectors and provides electromagnetic interference protection for critical circuits.

- Same dimensions as the non-filtered standard MIL-spec connectors with the exception of back shell length. (See Catalog 12-020).
- Uses non-removable solder cup terminated contacts.
- Shells are impact extruded or machined bar stock aluminum and are available in several conductive platings.
- Applications include power transmission, medical communications, and ground support equipment.

The following insert arrangements within the 5015 family have the same alternate insert rotations for W, X, Y and Z, which are:

| Degrees |       |       |       |       |       |
|---------|-------|-------|-------|-------|-------|
| W       | X     | Y     | Z     |       |       |
| 80      | 110   | 250   | 280   |       |       |
| 16-7    | 20-22 | 22-29 | 24-17 | 28-16 | 32-13 |
| 18-5    | 22-6  | 22-33 | 24-20 | 28-17 | 32-22 |
| 18-9    | 22-12 | 22-34 | 24-21 | 28-19 | 32-AF |
| 18-13   | 22-14 | 24-1  | 24-28 | 28-20 | 36-1  |
| 18-14   | 22-15 | 24-3  | 28-1  | 28-21 | 36-7  |
| 20-7    | 22-16 | 24-4  | 28-4  | 32-1  | 36-8  |
| 20-8    | 22-17 | 24-5  | 28-8  | 32-3  | 36-13 |
| 20-9    | 22-18 | 24-6  | 28-9  | 32-4  | 40-AR |
| 20-12   | 22-19 | 24-7  | 28-10 | 32-6  | 40-AS |
| 20-14   | 22-21 | 24-12 | 28-11 | 32-9  | 40-AT |
| 20-16   | 22-24 | 24-14 | 28-14 | 32-10 | 40-AU |
| 20-20   | 22-25 | 24-16 | 28-15 | 32-12 |       |

The following are additional 5015 insert arrangements with alternate rotations.

| Insert Arrangement | Degrees |     |     |     |
|--------------------|---------|-----|-----|-----|
|                    | W       | X   | Y   | Z   |
| 10SL-4             | 63      | -   | -   | -   |
| 12S-3              | 70      | 145 | 215 | 290 |
| 14S-2              | -       | 120 | 240 | -   |
| 14S-5              | -       | 110 | -   | -   |
| 14S-7              | 90      | 180 | 270 | -   |
| 14S-9              | 70      | 145 | 215 | 290 |
| 16-9               | 35      | 110 | 250 | 325 |
| 16-10              | 90      | 180 | 270 | -   |
| 16-11              | 35      | 110 | 250 | 325 |
| 16-13              | 35      | 110 | 250 | 325 |
| 16S-1              | 80      | -   | -   | 280 |
| 16S-4              | 35      | 110 | 250 | 325 |
| 16S-5              | 70      | 145 | 215 | 290 |
| 16S-6              | 90      | 180 | 270 | -   |
| 16S-8              | -       | 170 | 265 | -   |
| 18-1               | 70      | 145 | 215 | 290 |
| 18-3               | 35      | 110 | 250 | 325 |
| 18-4               | 35      | 110 | 250 | 325 |
| 18-8               | 70      | -   | -   | 290 |
| 18-10              | -       | 120 | 240 | -   |
| 18-11              | -       | 170 | 265 | -   |
| 18-12              | 80      | -   | -   | 280 |
| 18-15              | -       | 120 | 240 | -   |
| 18-20              | 90      | 180 | 270 | -   |
| 18-22              | 70      | 145 | 215 | 290 |
| 18-29              | 90      | 180 | 270 | -   |
| 20-3               | 70      | 145 | 215 | 290 |

\* MIL-DTL-5015 supersedes MIL-C-5015.



### FAN Connectors

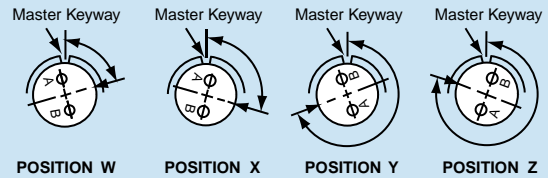

Views looking into front face of pin insert or rear of socket insert.

| Insert Arrangement | Degrees |     |     |     |
|--------------------|---------|-----|-----|-----|
|                    | W       | X   | Y   | Z   |
| 20-4               | 45      | 110 | 250 | -   |
| 20-5               | 35      | 110 | 250 | 325 |
| 20-6               | 70      | 145 | 215 | 290 |
| 20-15              | 80      | -   | -   | 280 |
| 20-17              | 90      | 180 | 270 | -   |
| 20-18              | 35      | 110 | 250 | 325 |
| 20-19              | 90      | 180 | 270 | -   |
| 20-21              | 35      | 110 | 250 | 325 |
| 20-23              | 35      | 110 | 250 | 325 |
| 20-24              | 35      | 110 | 250 | 325 |
| 20-27              | 35      | 110 | 250 | 325 |
| 20-29              | 80      | -   | -   | 280 |
| 22-1               | 35      | 110 | 250 | 325 |
| 22-2               | 70      | 145 | 215 | 290 |
| 22-4               | 35      | 110 | 250 | 325 |
| 22-5               | 35      | 110 | 250 | 325 |
| 22-8               | 35      | 110 | 250 | 325 |
| 22-9               | 70      | 145 | 215 | 290 |
| 22-10              | 35      | 110 | 250 | 325 |
| 22-11              | 35      | 110 | 250 | 325 |
| 22-13              | 35      | 110 | 250 | 325 |
| 22-20              | 35      | 110 | 250 | 325 |
| 22-22              | -       | 110 | 250 | -   |
| 22-23              | 35      | -   | 250 | -   |
| 22-27              | 80      | -   | 250 | 280 |
| 22-28              | 80      | -   | -   | 280 |
| 22-63              | 20      | -   | -   | -   |
| 24-2               | 80      | -   | -   | 280 |
| 24-9               | 35      | 110 | 250 | 325 |
| 24-10              | 80      | -   | -   | 280 |
| 24-11              | 35      | 110 | 250 | 325 |
| 24-22              | 45      | 110 | 250 | -   |
| 24-27              | 80      | -   | -   | 280 |
| 28-2               | 35      | 110 | 250 | 325 |
| 28-3               | 70      | 145 | 215 | 290 |

| Insert Arrangement | Degrees |     |     |     |
|--------------------|---------|-----|-----|-----|
|                    | W       | X   | Y   | Z   |
| 28-5               | 35      | 110 | 250 | 325 |
| 28-6               | 70      | 145 | 215 | 290 |
| 28-7               | 35      | 110 | 250 | 325 |
| 28-12              | 90      | 180 | 270 | -   |
| 28-18              | 70      | 145 | 215 | 290 |
| 28-22              | 70      | 145 | 215 | 290 |
| 28-AY              | 45      | 110 | 250 | -   |
| 32-2               | 70      | 145 | 215 | 290 |
| 32-5               | 35      | 110 | 250 | 325 |
| 32-7               | 80      | 125 | 235 | 280 |
| 32-8               | 80      | 125 | 235 | 280 |
| 32-15              | 35      | 110 | 250 | 280 |
| 32-17              | 45      | 110 | 250 | -   |
| 32-25              | 60      | 120 | -   | -   |
| 32-48              | 80      | -   | -   | -   |
| 32-64              | 80      | 100 | 110 | 250 |
| 32-68              | 30      | -   | -   | -   |
| 32-82              | 30      | -   | -   | -   |
| 36-3               | 70      | 145 | 215 | 290 |
| 36-4               | 70      | 145 | 215 | 290 |
| 36-5               | -       | 120 | 240 | -   |
| 36-6               | 35      | 110 | 250 | 325 |
| 36-9               | 80      | 125 | 235 | 280 |
| 36-10              | 80      | 125 | 235 | 280 |
| 36-14              | 90      | 180 | 270 | -   |
| 36-15              | 60      | 125 | 245 | 305 |
| 36-AF              | 65      | -   | -   | -   |
| 40-1               | 65      | 130 | 235 | 300 |
| 40-5               | 33      | -   | -   | 270 |
| 40-9               | 65      | 125 | 225 | 310 |
| 40-10              | 65      | 125 | 225 | 310 |
| 40-35              | 70      | 130 | 230 | 290 |
| 40-AD              | 45      | -   | -   | -   |
| 40-AG              | 37      | 74  | 285 | 322 |
| 40-AP              | 35      | 110 | 250 | 325 |
| 40-AV              | 90      | 180 | 270 | -   |

# FAN (MIL-DTL-5015) Box Mounting Receptacle



### PART #

To complete, see how to order pages 288-289.

| Filter Connector Designator | Connector Filter Type | Shell Finish | Shell Style | Shell Size & Insert Arrg | Type of Contact/ Keyway Position |
|-----------------------------|-----------------------|--------------|-------------|--------------------------|----------------------------------|
| 21                          | 26                    | X            | 2           | XX-XX                    | X                                |

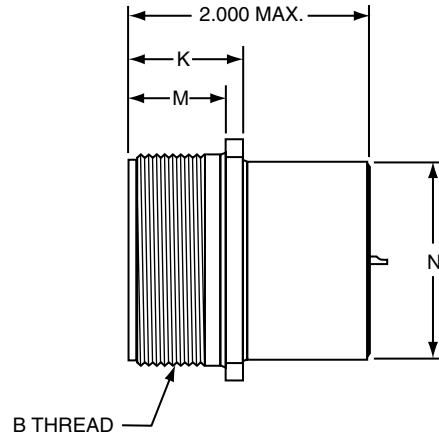
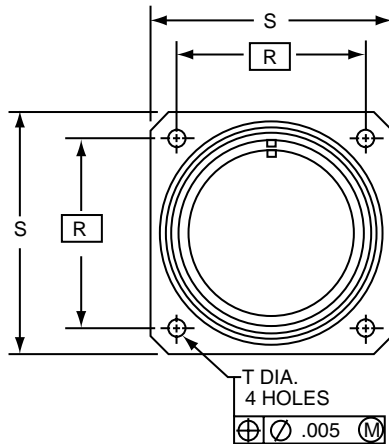

**21-26X2XX-XXX**

Note: MIL-DTL-5015 supersedes MIL-C-5015.

| Shell Size | B Thread Class 2A (Plated) | M<br>+.010<br>-.000 | K<br>+.020<br>-.010 | N Dia.<br>+.010<br>-.000 | R<br>TP | S<br>±.031 | T Dia.<br>+.004<br>-.002 |
|------------|----------------------------|---------------------|---------------------|--------------------------|---------|------------|--------------------------|
| 8S         | .5000-28 UNEF              | .562                | .672                | .375                     | .594    | .875       | .120                     |
| 10S        | .6250-24 UNEF              | .562                | .672                | .500                     | .719    | 1.000      | .120                     |
| 10SL       | .6250-24 UNEF              | .562                | .672                | .625                     | .719    | 1.000      | .120                     |
| 12S        | .7500-20 UNEF              | .562                | .672                | .625                     | .812    | 1.094      | .120                     |
| 12         | .7500-20 UNEF              | .750                | .860                | .625                     | .812    | 1.094      | .120                     |
| 14S        | .8750-20 UNEF              | .562                | .672                | .750                     | .906    | 1.188      | .120                     |
| 14         | .8750-20 UNEF              | .750                | .860                | .750                     | .906    | 1.188      | .120                     |
| 16S        | 1.0000-20 UNEF             | .562                | .672                | .875                     | .969    | 1.281      | .120                     |
| 16         | 1.0000-20 UNEF             | .750                | .860                | .875                     | .969    | 1.281      | .120                     |
| 18         | 1.1250-18 UNEF             | .750                | .891                | 1.000                    | 1.062   | 1.375      | .120                     |
| 20         | 1.2500-18 NEF              | .750                | .891                | 1.125                    | 1.156   | 1.500      | .120                     |
| 22         | 1.3750-18 NEF              | .750                | .891                | 1.250                    | 1.250   | 1.625      | .120                     |
| 24         | 1.5000-18 NEF              | .812                | .953                | 1.375                    | 1.375   | 1.750      | .147                     |
| 28         | 1.7500-18 NS               | .812                | .953                | 1.625                    | 1.562   | 2.000      | .147                     |
| 32         | 2.0000-18 NS               | .875                | 1.031               | 1.875                    | 1.750   | 2.250      | .173                     |
| 36         | 2.2500-16 UN               | .875                | 1.031               | 2.062                    | 1.983   | 2.500      | .173                     |
| 40         | 2.5000-16 UN               | .875                | 1.031               | 2.312                    | 2.188   | 2.750      | .173                     |

All dimensions for reference only.

III 38999  
II  
I  
SJT

26482  
Matrix 2

83723 III  
Matrix Pyle

5015  
Crimp Rear Release Matrix

26500 Pyle

Printed  
Circuit Board

EMI Filter  
Transient

Fiber Optics

High Speed  
Contacts

Options  
Others

Filter adapters present an effective and economical method of introducing EMI/EMP protection to an installed system. The adapter series of filter connectors from Amphenol are available to intermate with all the popular MIL-Specs.

**Features of the Amphenol Adapter include:**

- Planar technology from the industry's leader in circulars
- Filter products
- MOV or diode capability for transient protection
- Wide range of tooled patterns
- Space qualified components



Installation of the adapter is quick and efficient, requiring no tools, fixtures or extended downtime. Simply unmate the existing cable harness from the receptacle; attach the coupling nut to the receptacle on the unit; then mate the cable harness to the receptacle side of the adapter. Several design alternatives are available that will help ensure that the adapter remains permanently attached to either the cable harness or the unit receptacle.

**FPT Adapter**  
**21-900075-XXX**

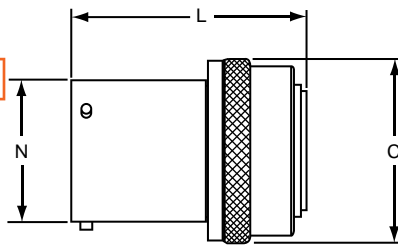

**FTV Adapter**  
**21-900529-XXX**

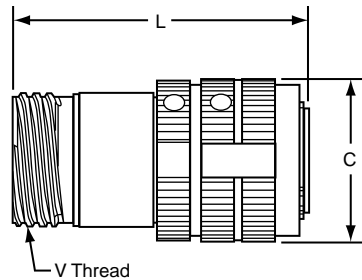

**FJT Adapter**  
**21-900393-XXX**

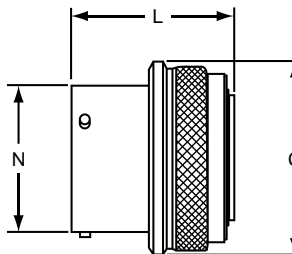

**FLJT Adapter**  
**21-900423-XXX**

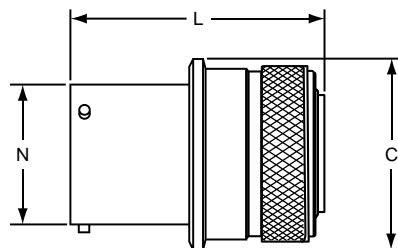

| FPT Shell Size | C Dia. Ref. | N Dia. +.001 - .005 | L Max. |
|----------------|-------------|---------------------|--------|
| 8              | .729        | .473                | 1.626  |
| 10             | .851        | .590                | 1.626  |
| 12             | 1.035       | .750                | 1.626  |
| 14             | 1.158       | .875                | 1.626  |
| 16             | 1.280       | 1.000               | 1.626  |
| 18             | 1.403       | 1.125               | 1.626  |
| 20             | 1.525       | 1.250               | 1.688  |
| 22             | 1.648       | 1.375               | 1.688  |
| 24             | 1.770       | 1.500               | 1.688  |

| FTV Shell Size | C Dia. Ref. | V Thread 0.1P-0.3L-TS Class 2A | L Max. |
|----------------|-------------|--------------------------------|--------|
| 9              | .845        | .6250                          | 2.257  |
| 11             | .950        | .7500                          | 2.257  |
| 13             | 1.121       | .8750                          | 2.257  |
| 15             | 1.249       | 1.0000                         | 2.257  |
| 17             | 1.386       | 1.1875                         | 2.257  |
| 19             | 1.493       | 1.2500                         | 2.257  |
| 21             | 1.620       | 1.3750                         | 2.257  |
| 23             | 1.737       | 1.5000                         | 2.257  |
| 25             | 1.864       | 1.6250                         | 2.257  |

| FJT Shell Size | C Dia. +.011 - .010 | N Dia. +.001 - .005 | L Max. |
|----------------|---------------------|---------------------|--------|
| 8              | .847                | .473                | 1.397  |
| 10             | .969                | .590                | 1.397  |
| 12             | 1.143               | .750                | 1.397  |
| 14             | 1.255               | .875                | 1.397  |
| 16             | 1.388               | 1.000               | 1.397  |
| 18             | 1.510               | 1.125               | 1.397  |
| 20             | 1.633               | 1.250               | 1.397  |
| 22             | 1.756               | 1.375               | 1.397  |
| 24             | 1.878               | 1.500               | 1.397  |

| FLJT Shell Size | C Dia. +.011 - .010 | N Dia. +.001 - .005 | L Max. |
|-----------------|---------------------|---------------------|--------|
| 9               | .920                | .572                | 2.038  |
| 11              | 1.045               | .700                | 2.038  |
| 13              | 1.246               | .850                | 2.038  |
| 15              | 1.371               | .975                | 2.038  |
| 17              | 1.496               | 1.100               | 2.038  |
| 19              | 1.616               | 1.207               | 2.038  |
| 21              | 1.743               | 1.332               | 2.038  |
| 23              | 1.866               | 1.457               | 2.038  |
| 25              | 1.991               | 1.582               | 2.038  |

All dimensions for reference only. Consult Amphenol, Sidney, NY for ordering information.

38999  
SJT I II III

26482  
Matrix 2

83723 III  
Matrix Pyle

5015  
Crimp Rear Release Matrix

26500 Pyle

Printed  
Circuit Board

EMI Filter  
Transient

Fiber Optics

High Speed  
Contacts

Options  
Others



# Transient Protection

## MOV– Metal Oxide Varistor Connectors

- Filter connector size package
- Protection for 14, 31, 38 DC voltage circuits
- Radiation hardened
- No additional circuits required
- Low impedance
- Increased reliability
- Nanosecond response time
- Elimination of costly external suppression assemblies

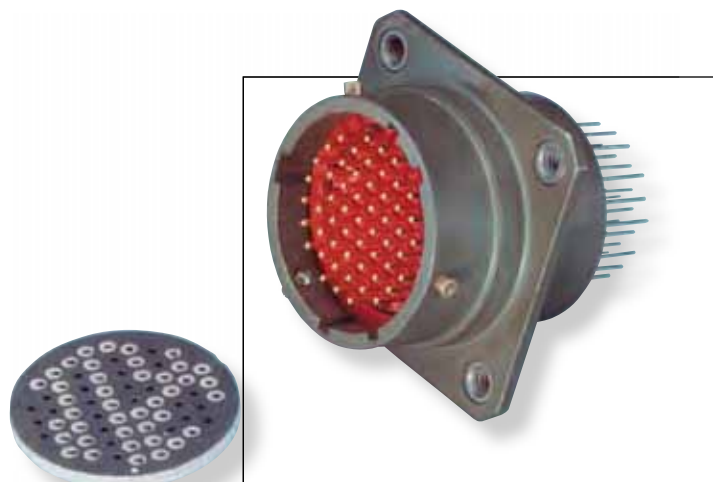

**MOV**

The Amphenol® MOV Connector offers the versatility of a standard connector, with transient protection for sensitive circuits. Transients in electrical circuits caused by a sudden release of stored energy can originate within or outside of the circuit and may be repeatable or random.

Regardless of frequency or origin, transient caused failures generated by load switching, lightning, electrostatic discharge (ESD) and electromagnetic pulse (EMP) can destroy unprotected IC components.

Compatible with present filter connector assembly procedures, MOVs can be combined with existing filters. Internal housing of the MOV offers weight and space savings over other protection methods available today, and eliminates costly and bulky exterior suppression mechanisms in appropriate situations. MOVs are presently available in contact sizes 22, 20 and 16.

Transient protection can be provided in receptacle, plug or adapter configuration. These connectors are intermateable and intermountable with the following MIL-Specs:

- MIL-DTL-5015
- MIL-DTL-38999
- MIL-DTL-26482
- MIL-DTL-83723
- MIL-DTL-26500
- MIL-DTL-27599

38999  
III  
II  
I  
SJT

26482  
Matrix 2

83723 III  
Matrix  
Pyle

5015  
Crimp Rear  
Release Matrix

26500 Pyle

Printed  
Circuit Board

**EMI Filter  
Transient**

Fiber Optics

High Speed  
Contacts

Options  
Others

**M.O.V. PERFORMANCE CHARACTERISTICS**

| Designation | Contact Size | Maximum Rating (125°C) |                      |                        |                         | Specifications (25°C)        |      |      |   |          |                      | Maximum Leakage Current at V <sub>t</sub> (dc) |                     |                     |                |
|-------------|--------------|------------------------|----------------------|------------------------|-------------------------|------------------------------|------|------|---|----------|----------------------|--|---------------------|---------------------|----------------|
|             |              | Continuous             |                      | Transient              |                         | Varistor Voltage at 1mA (DC) |      |      | Maximum Clamping Voltage V <sub>c</sub> at Test Current I <sub>p</sub> (8/20μS) |          | Capacitance at 1 MHz |  | I <sub>L</sub> Max. | I <sub>L</sub> Max. | V <sub>t</sub> |
|             |              | DC Voltage             | RMS Voltage          | Energy (10/1000μS)     | Peak Current (8/20μS)   |                              |      |      |   |          |                      |  |                     |                     |                |
|             |              | V <sub>m</sub> Volts   | V <sub>m</sub> Volts | W <sub>tm</sub> Joules | I <sub>tm</sub> Amperes | Min.                         | Max. | 25°C | 125°C   | DC Volts |                      |  |                     |                     |                |
| F14         | 22           | 14                     | 10                   | 1.5                    | 250                     | 18.5                         | 22   | 25.5 | 42  | 10       | 800                  | 2000   | 5                   | 50                  | 14             |
| F31         | 22           | 31                     | 25                   | 1.5                    | 250                     | 35                           | 39   | 48   | 85  | 5        | 400                  | 1400   | 5                   | 50                  | 28             |
| F38         | 22           | 38                     | 30                   | 1.5                    | 250                     | 42                           | 47   | 58   | 100   | 5        | 200                  | 1000   | 5                   | 50                  | 36             |
| F45         | 22           | 45                     | 35                   | 1.5                    | 250                     | 53                           | 59   | 68   | 100   | 5        | 200                  | 850  | 5                   | 50                  | 45             |
| F31         | 20           | 31                     | 25                   | 2                      | 300                     | 35                           | 39   | 48   | 85  | 10       | 400                  | 1400   | 5                   | 50                  | 28             |
| F38         | 20           | 38                     | 30                   | 2                      | 300                     | 42                           | 47   | 58   | 100   | 10       | 200                  | 1000   | 5                   | 50                  | 36             |
| F45         | 20           | 45                     | 35                   | 2                      | 300                     | 53                           | 59   | 68   | 100   | 10       | 200                  | 850  | 5                   | 50                  | 45             |
| F38         | 16           | 38                     | 30                   | 3                      | 350                     | 42                           | 47   | 58   | 100   | 20       | 200                  | 1000   | 5                   | 50                  | 36             |
| F45         | 16           | 45                     | 35                   | 3                      | 350                     | 53                           | 59   | 68   | 100   | 20       | 200                  | 850  | 5                   | 50                  | 45             |

NOTE: Continuous voltage ratings are based on 1000 hour reliability assurance tests at 125°C rated ambient temperature per MIL-STD-202 method 108. Contact Amphenol Sidney for options not listed in chart.

The following charts show the typical MOV response to an input pulse open circuit of 1000V and 10A peak square wave with a 5 nanosecond rise time in a 50 Ohm system.

The following chart shows response time and output voltage of a typical MOV with 1000V, 5 nanosecond, 2.5A input pulse mounted in an LJT 13-35P connector. Test was performed without load.

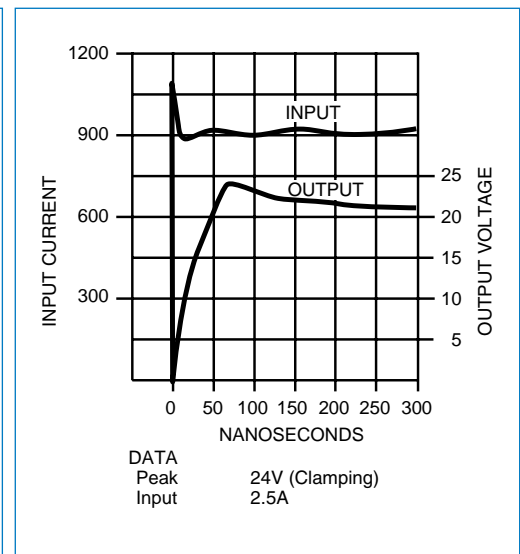
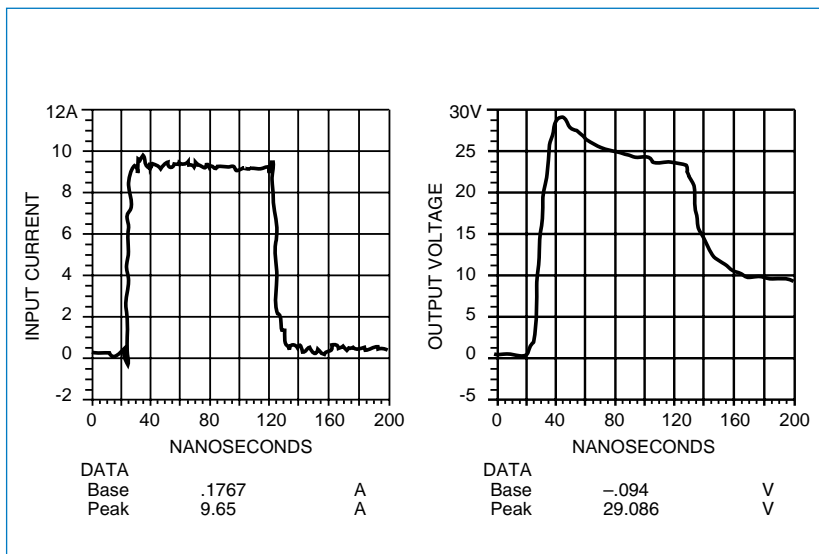

38999  
SJT I II III

26482  
Matrix 2

83723 III  
Matrix Pyle

5015  
Crimp Rear Release Matrix

26500 Pyle

Printed  
Circuit Board

EMI Filter  
Transient

Fiber Optics

High Speed  
Contacts

Options  
Others

# Transient Protection Diode Connectors

- Clamping voltage as low as 11.9 volts
- Low capacitance – suitable for high frequency applications
- Unipolar or bipolar – using existing proven diode technology
- Protection for 5.8 to 60 VDC circuits
- No additional circuits required
- Low impedance – high frequency response
- Increased reliability
- Nanosecond response time
- Elimination of costly external suppression assemblies
- Screening to applicable requirements of MIL-S-19500TX/TXV available
- Keeps transients outside of the box
- Minimizes fast transient voltage overshoot

The Amphenol® Diode Connector offers the versatility of a standard connector, with transient protection for sensitive circuits, such as TTL Lines.

Transients in electrical circuits caused by a sudden release of stored energy can originate within or outside of the circuit and may be repeatable or random.

Regardless of frequency or origin, transient caused failures generated by load switching, lightning, electrostatic discharge (ESD) and electromagnetic pulse (EMP) can destroy unprotected IC components.

Compatible with present filter connector assembly procedures, diodes can stand alone or can be combined in series with filters. Internal housing of the diode offers weight and space savings over other protection methods available today, and eliminates costly and bulky exterior suppression mechanisms in appropriate situations. Diodes are presently available in contact sizes 22 and 20.

Transient protection can be provided in receptacle, plug or adapter configurations. These connectors are intermateable and intermountable with the following MIL-Specs:



**Diode** Diode Connector and Adapter



Close-up View of Diode Contact

- MIL-DTL-5015
- MIL-DTL-26482
- MIL-DTL-26500
- MIL-DTL-27599
- MIL-DTL-38999
- MIL-DTL-83723

## DIODE CONTACT PULSE TEST, ±5.8 DIODE

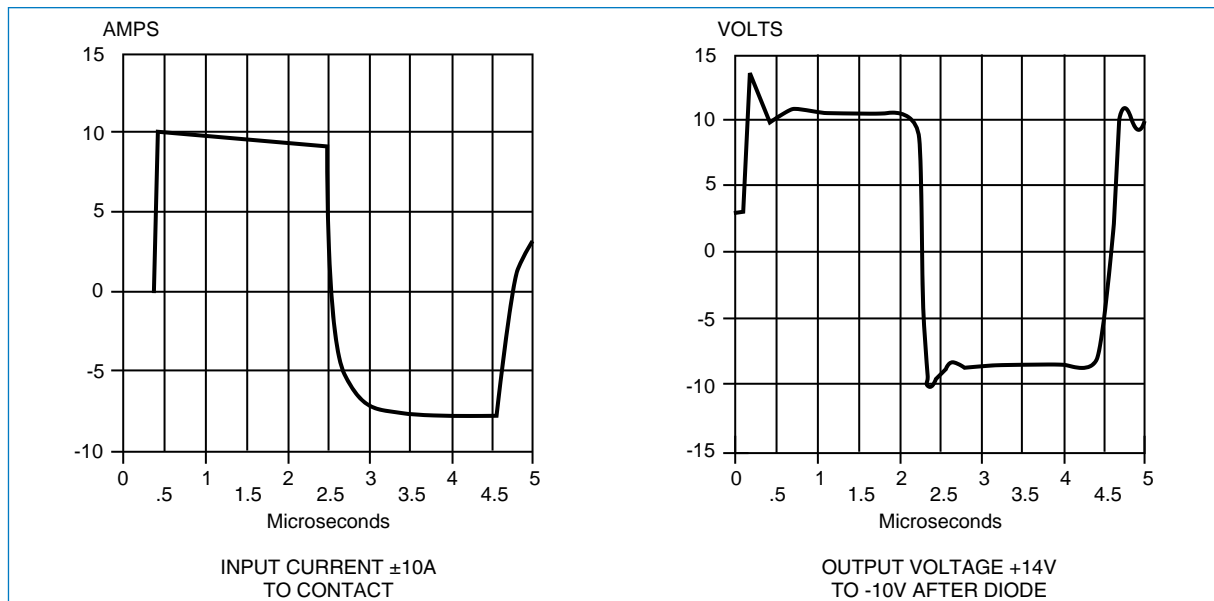

III  
II  
I  
SJT  
38999

Matrix 2  
26482

Matrix  
Pyle  
83723 III

Crimp Rear  
Release Matrix  
5015

Pyle  
26500

Printed  
Circuit Board

EMI Filter  
Transient

Fiber Optics

High Speed  
Contacts

Options  
Others

### STANDARD DIODE CONNECTOR CHARACTERISTICS AT 25°C

| Stand-off Voltage † (VDC) | Max. Capacitance* (pf) | Breakdown Voltage at 1 mA (VDC) | Max. Clamping Voltage (8 x 20µ sec. pulse) | Leakage Current at Stand-off Voltage (µA) | Power Capability † 20µs Exp. Impulse (Peak) (Watts) |
|---------------------------|------------------------|---------------------------------|--|---|---|
| + 5.8                     | 1600                   | + 6.45 to + 7.1**               | +11.9                                      | <100                                      | 1000  |
| ± 5.8                     | 1000                   | ± 6.45 to ± 7.1**               | ±11.9                                      | <150                                      | 1000  |
| ± 7.0                     | 750                    | ± 7.3 to ± 9.3                  | ±13.5                                      | <10                                       | 1000  |
| ± 8.0                     | 750                    | ± 8.2 to ±10.6                  | ±15.4                                      | <5  | 1000  |
| + 8.0                     | 1500                   | + 8.5 to +10.6                  | +15.4                                      | <5  | 1000  |
| ±10.0                     | 500                    | ±11.1 to ±12.3                  | ±17.0                                      | <1  | 1000  |
| +10.0                     | 1100                   | +11.1 to +12.3                  | +17.0                                      | <1  | 1000  |
| ±15.0                     | 500                    | ±16.7 to ±18.5                  | ±24.9                                      | <1  | 1000  |
| +15.0                     | 750                    | +16.2 to +19.2                  | +24.9                                      | <1  | 1000  |
| -15.0                     | 750                    | -16.2 to -19.2                  | -24.9                                      | <1  | 1000  |
| ±17.0                     | 500                    | ±18.9 to ±23.0                  | ±32.0                                      | <1  | 1000  |
| +17.1                     | 600                    | +19.0 to +21.0                  | +27.7                                      | <1  | 1000  |
| ±22.0                     | 500                    | ±25.7 to ±28.4                  | ±38.0                                      | <1  | 1000  |
| ±25.0                     | 500                    | ±27.8 to ±30.7                  | ±40.5                                      | <1  | 1000  |
| +28.0                     | 500                    | +30.5 to +35.7                  | +46.4                                      | <1  | 1000  |
| ±33.3                     | 500                    | +37.1 to +41.0                  | ±53.9                                      | <1  | 1000  |
| +33.3                     | 500                    | +37.1 to +41.0                  | +53.9                                      | <1  | 1000  |
| ±40.0                     | 500                    | ±44.4 to ±49.1                  | ±64.5                                      | <1  | 1000  |
| ±45.0                     | 500                    | ±47.1 to ±58.1                  | ±84.2                                      | <1  | 1000  |
| +57.8                     | 500                    | +64.6 to +71.4                  | +95.2                                      | <1  | 1000  |
| ±57.8                     | 500                    | ±64.6 to ±71.4                  | ±95.2                                      | <1  | 1000  |

Clamping Time -

Unipolar: Less than 1 nanosecond, 0V to breakdown

Bipolar: Less than 5 nanoseconds, 0V to breakdown

\* Lower capacitance devices available; consult Amphenol, Sidney, NY.

\*\*This device only measured at 10ma

† Higher power ratings also available

Amphenol can provide COTS solutions utilizing leaded & surface mounted devices. For more information contact Amphenol Aerospace at 800-678-0141.

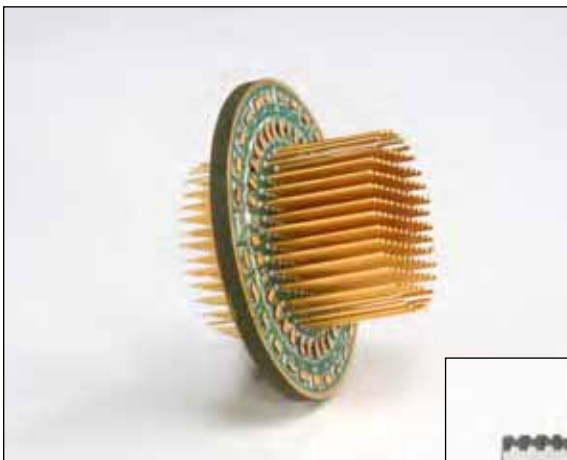

EMI Filter  
Transient

Fiber Optics

High Speed  
Contacts

Options  
Others

# Transient Protection

## ESA – Energy Shunting Assembly

The Amphenol® Energy Shunting Assembly (ESA) is a simple, compact unit which provides lightning and electromagnetic pulse (EMP) protection of systems in which many signal lines enter sensitive electronic equipment. The efficient packaging of the ESA circumvents the concept of one protective device per line. It provides a surge arrester which has the advantage of space saving and simplified assembly when compared to current protective devices which range from diodes to large spark gaps.

The current ESA design consists of two 53-pin contact, Mil-Standard, hermetic connectors assembled back to back, and encompassing a ground plate. A sealed chamber is formed within this thru-bulkhead unit, housing 53 in-line spark gaps. Introducing a controlled atmosphere enhances fast rise breakdown.

The ESA can be integrated with an EMI filter connector which can improve its performance. These two assemblies provide a method to help protect against lightning, EMP, EMI and TEMPEST effects.



**ESA** Energy Shunting Assembly

### Performance Characteristics

|   |                                   |                                    |
|---|-----------------------------------|------------------------------------|
| 1. DC breakdown voltage   |                                   | 230 Volts                          |
| 2. Maximum rated surge discharge current (8 x 20 microsecond pulse) |                                   | 5,000 Amperes per pin              |
| 3. Insulation resistance  |                                   | 10 <sup>10</sup> ohms minimum      |
| 4. Capacitance between each electrode and the ground plane          |                                   | Less than 2 pf                     |
| 5. Rate-of-rise breakdown voltage                                   | Maximum Breakdown Voltage (Volts) | Rate of Rise (Volts/microsecond)   |
|   | 600                               | 10                                 |
|   | 800                               | 1,000                              |
|   | 1,500                             | 10,000                             |
| 2,000   |                                   | 1000,000                           |
| 6. Surge breakdown unbalance (at 100 Volts/microseconds)            |                                   | 180 Volts                          |
| 7. Surge life (500 Ampere – 10 x 1,000 microsecond)                 |                                   | 400 Surges                         |
| 8. Hold-over voltage  |                                   | 100 Volts                          |
| 9. Arcing voltage   |                                   | 40 Volts                           |
| 10. Glow to arc transition point                                    |                                   | 1 Ampere                           |
| 11. Temperature range   |                                   | -40°F to 150°F<br>(233°K to 339°K) |

III  
II  
I  
SJT

38999

26482  
Matrix 2

83723 III  
Matrix  
Pyle

5015  
Crimp Rear  
Release Matrix

26500 Pyle

Printed  
Circuit Board

EMI Filter  
Transient

Fiber Optics

High Speed  
Contacts

Options  
Others



### The Hermetic Filter Connector

While only approximately 1/2 inch longer than standard series connectors, the hermetic filter connector provides all the benefits of a hermetic connector, as well as EMI protection for sensitive circuits. The filter assembly is protected by a fused glass insert within a unique steel housing. This design accounts for the connector's capability in tolerating high level static pressure, while maintaining a low level leakage rate. Applications include pressurized test equipment, environmental and toxic gas chambers, and moisture sealing on industrial equipment and missiles.



Hermetic Filter Connector

### Filtered Plug

This connector is designed for applications where EMI protection is essential, but access to the receptacle is denied. The filtered plug presents an alternative for the electrical engineer. The filter plug is designed with the same components as a standard filter receptacle, but offers the option of being mounted on the cable harness. This device is a cost effective method of achieving EMI protection when length restrictions prohibit inclusion of an adapter to the system.



Filtered Plug

### Filter Connectors can also incorporate high frequency coax, twinax, triax, quadax and differential twinax contacts.

Amphenol MIL-DTL-38999 Series III connectors are the most commonly used connectors for incorporation of shielded contacts along with traditional crimp contacts. High performance shielded coaxial, twinax and triax contacts are available to fit various RG and special cables. They eliminate discontinuities or impedance variations due to movement of parts under axial load. Size 8 quadax and differential twinax contacts provide high speed data transfers.



Filter Connectors with Coax Shielded Contacts

### Filter Connectors with Flex Termination

Flex circuits are available for MIL-DTL-38999, MIL-DTL-5015 and MIL-DTL-26482 filter connectors. They are offered in flat or sculptured styles and provide flexibility in assembling to printed circuit boards. Through Amphenol's Advanced Circuit Technology division, these strong and rigid, yet highly flexible circuits eliminate the need to purchase and attach individual pins or connectors. Thus they promote system automation, reduce space requirements and lower installation costs. Sculptured® Flexible Circuits have built-in terminations which eliminate the failure associated with crimped or soldered-on contacts, and geometrically fit the tight space requirements within a unit.



Flex Circuitry for Attachment to  
Printed Circuit Boards



MIL-DTL-38999 with Quadrax Contacts

For more information on these specials, consult Amphenol Aerospace and see our website at [www.amphenol-aerospace.com](http://www.amphenol-aerospace.com).

38999  
SJT I II III

26482  
Matrix 2

83723 III  
Matrix Pyle

5015  
Crimp Rear  
Release Matrix

26500 Pyle

Printed  
Circuit Board

EMI Filter  
Transient

Fiber Optics

High Speed  
Contacts

Options  
Others



# Amphenol Fiber Optic Interconnects

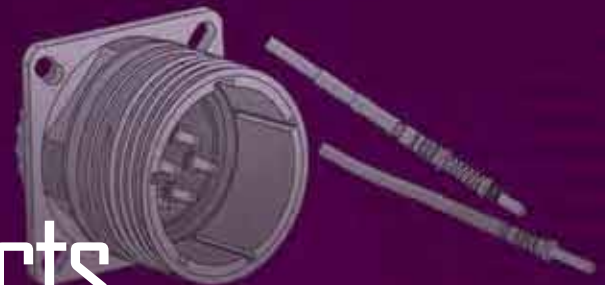

CF38999 with MIL-PRF-29504 Size 16 Fiber Optic Termini



CF38999 with Size 20 Fiber Optic Termini



MT38999 with MT Fiber Optic Termini



**New  
Featured**

ARINC 801 Fiber Optic Connector and Termini



Hybrid with Fiber Optic Termini and High Speed Contacts



## TABLE OF CONTENTS

### Fiber Optic Interconnect Products for Military, Aerospace and Harsh Environments

- Table of Contents . . . . . 339
- Product Overview . . . . . 340

### Fiber Optic Termini

- MIL-PRF-29504/4 & /5 Multi-Mode Termini, size 16, Pin and Socket . . . 341
- MIL-PRF-29504 Type Single Mode Termini size 16, Pin and Socket. . . . 342
- 90° Multi-Mode Termini, Size 16, Pin and Socket . . . . . 343
- Multi-mode Termini, HD20, Size 20, Pin and Socket . . . . . 344

### Multi-Channel Circular Connectors with Fiber Optics

- CF38999 Multi-Channel Connectors the Industry Standard . . . . . 345
  - How to Order . . . . . 346
  - Insert Availability . . . . . 347
  - Insert Arrangements . . . . . 348, 349
  - Wall Mount Receptacle, Box Mount Receptacle . . . . . 350
  - Jam Nut Receptacle, Line Receptacle . . . . . 351
  - Straight Plug . . . . . 352
- JSFC17 Socket and JSFC18 Pin Contact How to Order . . . . . 353
- JSFC15 Fiber Optic Receptacle  
JSFC16 Fiber Optic Plug How to Order . . . . . 354
- JSFC 15 Fiber Optic Receptacle, JSFC 16 Fiber Optic Plug Shell Styles 355
- ARINC 801 Genderless, Keyed Termini . . . . . 356
- Multi-Channel, MIL-DTL-38999 III with ARINC 801 Inserts . . . . . 357
- MT Ferrule Termini . . . . . 358
- Multi-Channel Fiber Optic with MT Ferrule Inserts, How to Order . . . . . 359
- Fiber Optic Bulkhead Feed-Through with Size 16 Pin Termini . . . . . 360
- Accessories for Circular Connectors . . . . . 361
- Application Tools for Multi-Mode Termini. . . . . 362
- Fiber Optic Cable Systems . . . . . 363
- Fiber Optic Cable Systems Designer's Guide . . . . . 364



### Fiber Optic Interconnects Markets:

- Military & Commercial Aviation
- Military Vehicles
- Radar, Missiles & Battlefield Equipment
- Medical & Test Equipment
- C4ISR





38999  
SJT I II III

26482  
Matrix 2

83723 III  
Matrix Pyle

5015  
Crimp Rear  
Release Matrix

26500 Pyle

Printed  
Circuit Board

EMI Filter  
Transient

Fiber Optics

High Speed  
Contacts





Options  
Others

### Fiber Optics in MIL-DTL-38999 Series III Connectors

Amphenol Aerospace offers a wide range of fiber optic interconnect solutions for use in the harsh environments found in military and aerospace applications. Amphenol Aerospace has established the rugged and reliable MIL-DTL-38999 as a common connector shell platform that houses a wide variety of fiber optic termini including MIL-PRF-29504\*, HDF20, ARINC 801 and MT ferrules.

MIL-DTL-38999 Series III Tri-Start connectors are available in various insert arrangements, materials and finishes to meet any type of environmental requirement. Our MIL-PRF-29504 and HD20 termini can be combined with most of our copper contacts to create a large assortment of hybrid fiber/copper connector combinations.

\*MIL-PRF-29504 supersedes MIL-T-29504. (MIL-T-29504 is still available; consult Amphenol Aerospace for more information.)

| Connector   | Termination              | Features   |
|---|--------------------------|--|
|  | <b>MIL-PRF-29504</b>     | CF38999 Pin and socket termini that feature high precision, pre-radiused ceramic ferrules to help improve insertion loss performance and reduce polishing time. Products are available in both single mode and multi-mode versions. The socket has a plastic protective shroud over the ceramic alignment sleeve that incorporates a built-in anti-rotation feature.<br><b>HD20</b> - Pin and socket termini that have the same benefits of the MIL-PRF-29504 termini, but in a smaller, size 20 contact that allows for increased density in D38999 connector shells. |
|  | <b>JSF</b>               | Tight tolerance, nickel-plated composite plugs and receptacles approved for use in F35/JSF applications.   |
|  | <b>ARINC 801 termini</b> | Genderless fiber optic termini that use a precision 1.25 mm ceramic ferrule. Precision inserts with guide pins and keyed termini enhance multi-mode and single mode performance. ARINC 801 termini facilitate an angled polish for improved return loss.   |
|  | <b>MT ferrules</b>       | Industry-standard, very high density plastic ferrules available in either 12-fiber or 24-fiber versions, in multi-mode PC, single mode PC, and single mode APC configurations.   |

Amphenol Aerospace also supplies a wide range of rectangular interconnect products containing MIL-PRF-29504 HD20 and MT Fiber Optic termini. Our rectangular interconnect products include a variety of applications including LRM surface mount and rack & panel styles - all available in hybrid fiber/copper configurations

## Size 16, Pin and Socket

### HOW TO ORDER

#### Fiber Optic Pins Ordering Information

| Amphenol Part Number | Fiber Size†<br>Core/Cladding | A Dia. Ref.<br>(Microns) | Ferrule Hole Tolerance | Reference Only<br>M29504/4-XXXX |
|----------------------|------------------------------|--------------------------|------------------------|---------------------------------|
| CF-198142-125        | 9/125<br>(Single mode)       | 125                      | +1,-0                  | M201504/4-4300*                 |
| CF-198142-25A        | 9/125<br>(Single mode)       | 125.5                    | +1,-0                  | M29504/4-4208*                  |
| CF-198142-126        | 9/125<br>(Single mode)       | 126                      | +1,-0                  | M29504/4-4209*                  |
| CF-198036-010        | 50/125 &<br>62.5/125         | 127                      | +2,-0                  | Superseded by<br>MIL-PRF        |
| CF-198142-010        | 50/125 &<br>62.5/125         | 127                      | +2,-0                  | M29504/4-4040*                  |
| CF-198036-017        | 100/140                      | 145                      | +3,-0                  | Superseded by<br>MIL-PRF        |
| CF-198142-017        | 100/140                      | 145                      | +3,-0                  | M29504/4-4044*                  |
| CF-198036-29A        | 100/140/172<br>(Polyimide)   | 173                      | +1,-0                  | Superseded by<br>MIL-PRF        |
| CF-198142-29A        | 100/140/172<br>(Polyimide)   | 173                      | +1,-0                  | M29504/4-4293*                  |
| CF-198036-053        | 200/230                      | 236                      | +4,-0                  | Superseded by<br>MIL-PRF        |
| CF-198142-053        | 200/230                      | 236                      | +4,-0                  | M29504/4-4214*                  |

#### Fiber Optic Sockets Ordering Information

| Amphenol Part Number | Fiber Size†<br>Core/Cladding | A Dia. Ref.<br>(Microns) | Ferrule Hole Tolerance | Alignment Sleeve** | Reference Only<br>M29504/5-XXXX |
|----------------------|------------------------------|--------------------------|------------------------|--------------------|---------------------------------|
| CF-198143-125        | 9/125<br>(Single mode)       | 125                      | +1,-0                  | C                  | M29504/5-4309*                  |
| CF-198143-25A        | 9/125<br>(Single mode)       | 125.5                    | +1,-0                  | C                  | M29504/4-4237*                  |
| CF-198143-126        | 9/125<br>(Single mode)       | 126                      | +1,-0                  | C                  | M29504/5-4238*                  |
| CF-198035-010        | 50/125 &<br>62.5/125         | 127                      | +2,-0                  | M                  | Superseded by<br>MIL-PRF        |
| CF-198143-010        | 50/125 &<br>62.5/125         | 127                      | +2,-0                  | C                  | M29504/5-4046*                  |
| CF-198035-017        | 100/140                      | 145                      | +3,-0                  | M                  | Superseded by<br>MIL-PRF        |
| CF-198143-017        | 100/140                      | 145                      | +3,-0                  | C                  | M29504/5-4050*                  |
| CF-198035-29A        | 100/140/172<br>(Polyimide)   | 173                      | +1,-0                  | M                  | Superseded by<br>MIL-PRF        |
| CF-198143-29A        | 100/140/172<br>(Polyimide)   | 173                      | +1,-0                  | C                  | M29504/5-4296*                  |
| CF-198035-053        | 200/230                      | 236                      | +4,-0                  | M                  | Superseded by<br>MIL-PRF        |
| CF-198143-053        | 200/230                      | 236                      | +4,-0                  | C                  | M29504/5-4243*                  |

\* Consult Amphenol Aerospace, Sidney NY for qualification status.

† Additional fiber optic termini sizes available upon request; consult Amphenol Aerospace for availability.

\*\* C = Ceramic  
M = Metal



#### Multi-mode Size 16 Fiber Optic Termini

Designed for use in the size 16 contact cavities of Multi-channel MIL-DTL-38999 Series III Connectors and CF38999 Fiber Optic Connectors



#### Single Mode Size 16 Fiber Optic Termini

Designed for use in the size 16 contact cavities of Amphenol CF38999 Fiber Optic Connectors

III  
II  
I  
SJT  
38999

Matrix 2  
26482

Matrix  
Pyle  
83723 III

Release Matrix  
Crimp Rear  
5015

26500 Pyle

Printed  
Circuit Board

EM1 Filter  
Transient

Fiber Optics

High Speed  
Contacts

Options  
Others



**Amphenol® Multi-mode, Size 16 Termini Features:**

- Designed for use in size 16 cavities of MIL-DTL-38999 Series III and Amphenol CF38999 connectors
- Precision ceramic ferrules which precisely position the fiber within the termini.
- Material, provides protection for the ceramic alignment sleeve.
- Stainless steel termini bodies and springs.
- Allows for multiple fiber accommodations

**Amphenol® Single mode, Size 16 Termini Features:**

- Precision ceramic alignment sleeves insure accurate fiber to fiber alignment.
- Socket has threaded protective shroud with anti-rotation key, manufactured from rugged PEEK™
- Designed with similar high performance components as the size 16 multi-mode termini
- Maintains fiber optic/electrical hybrid capabilities

**Size 16 Single Mode Pin Termini**

**CF-198036-XXX**



**Size 16 Single Mode Socket Termini**

**CF-198035-XXX**

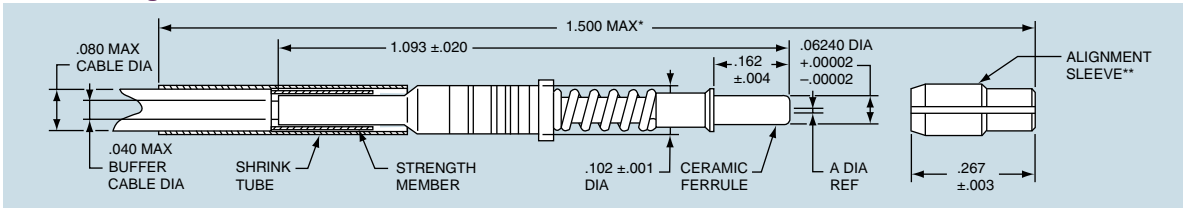

**Size 16 Multi-Mode Pin Termini**

**CF-198142-XXX**



**Size 16 Multi-Mode Socket Termini**

**CF-198143-XXX**



\* Indicated dimension when fully assembled.  
\*\* Alignment sleeve shipped unassembled.  
All dimensions for reference only.

# 90° Multi-Mode Termini Size 16, Pin and Socket

Amphenol provides 90°, size 16 fiber optic termini that can be used with multi-channel circular connectors. Consult Amphenol for the 90°, size 16 termini for use in LRM rectangular connectors. (Please consult Amphenol for availability of 90° size 20 termini).

## 90° Socket Termini (Size 16)



## Ordering Information for 90° Multi-mode Socket Termini

| Fiber Size†<br>Core/Cladding<br>Dia (Microns) | Socket, Size 16<br>Amphenol Part Number<br>For use in Circular<br>Connectors | A Dia Ref |         |
|---|--|-----------|---------|
|   |  | Inches    | Microns |
| 50/125  | CF-198111-010  | .0050     | 127     |
| 62.5/125                                      |  |           |         |
| 100/140                                       | CF-198111-017  | .0057     | 145     |
| 100/140/172                                   | CF-198111-29   | OR        | .0069   |
|   | CF-198111-29A  |           | 173     |

† Additional sizes available upon request: consult Amphenol, Sidney, NY for availability.  
 \* Consult Amphenol, Sidney, NY for ordering information.  
 \*\* Indicated dimension when fully assembled.  
 \*\*\* Shrink tubing and alignment sleeve are shipped unassembled.  
 For 90°, size 16 fiber optic termini for use in LRM rectangular connectors consult Amphenol, Sidney NY.  
 All dimensions for reference only.

## 90° Pin Termini (Size 16)

### Ordering Information for 90° Multi-mode Pin Termini

| Fiber Size†<br>Core/Cladding<br>Dia (Microns) | Pin, Size 16<br>Amphenol Part Number<br>For use in Circular<br>Connectors | A Dia Ref |         | B Max<br>(Inches) | C Ref<br>(Inches) |
|---|---|-----------|---------|-------------------|-------------------|
|   |   | Inches    | Microns |                   |                   |
| 50/125  | CF-198110-010   | .0050     | 127     | 1.121             | 1.100             |
| 62.5/125                                      |   |           |         |                   |                   |
| 100/140                                       | CF-198110-017   | .0057     | 145     | 1.121             | 1.100             |
| 100/140/172                                   | CF-198110-029   | OR        | .0069   | 1.121             | 1.100             |
|   | CF-198110-29A   |           | 173     |                   |                   |
| 50/125  | CF-198112-010   | .0050     | 127     | 1.003             | .900              |
| 62.5/125                                      |   |           |         |                   |                   |
| 100/140                                       | CF-198112-017   | .0057     | 145     | 1.003             | .900              |
| 100/140/172                                   | CF-198112-029   | OR        | .0069   | 1.003             | .900              |
|   | CF-198112-29A   |           | 173     |                   |                   |

† Additional sizes available upon request: consult Amphenol, Sidney, NY for availability.  
 \* Consult Amphenol, Sidney, NY for ordering information.  
 For 90°, size 16 fiber optic termini for use in LRM rectangular connectors consult Amphenol, Sidney NY.  
 All dimensions for reference only.



- III 38999
- II
- I
- SJT
- Matrix 2 26482
- Matrix 83723 III
- Pyle 5015
- Crimp Rear Release Matrix
- 26500 Pyle
- Printed Circuit Board
- EMI Filter Transient
- Fiber Optics
- High Speed Contacts
- Options Others

38999  
SJT I II III

26482  
Matrix 2

83723 III  
Matrix Pyle

5015  
Crimp Rear  
Release Matrix

26500 Pyle

Printed  
Circuit Board

EMI Filter  
Transient

Fiber Optics

High Speed  
Contacts

Options  
Others



### Multi-mode HDF20 Fiber Optic Termini

Designed for use in the size 20 contact cavities of Multi-channel MIL-DTL-38999 Series III Connectors and Amphenol CF38999 Fiber Optic Connectors

### Amphenol® Multi-mode, Size 20 Termini Features:

- 1mm precision ceramic ferrules
- Offers increased termini density
- Designed with similar high performance components as size 16 termini
- Maintains fiber optic/electrical hybrid capabilities
- Termination accomplished using epoxy/polish method.

### HOW TO ORDER

#### Multi-mode Termini (Size 20) for MIL-DTL-38999 Connectors

| Fiber Size†<br>Core/Cladding<br>Dia (Microns) | Amphenol Part Numbers |               | A Dia. Ref.<br>(Microns) | Ferrule<br>Hole<br>Tolerance |
|---|-----------------------|---------------|--------------------------|------------------------------|
|   | Size 20 Socket        | Size 20 Pin   |                          |                              |
| 50/125  | CF-198080-010         | CF-198081-010 | 127                      | +3,-0                        |
| 62.5/125                                      |                       |               |                          |                              |
| 100/140                                       | CF-198080-017         | CF-198081-017 | 145                      | +3,-0                        |

† Additional sizes available upon request: consult Sidney, NY for availability.

Size 20 Multi-mode  
Pin Terminus

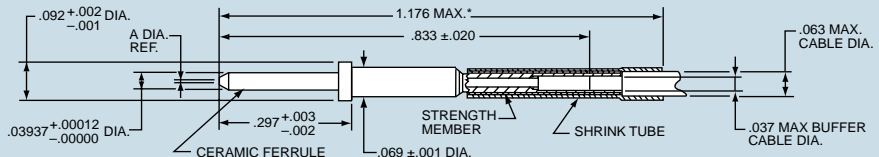

Size 20 Multi-mode  
Socket Terminus

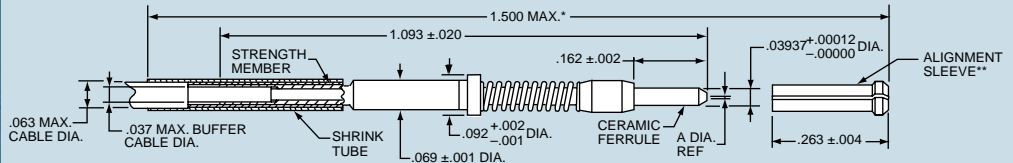

Amphenol® Multi-Channel fiber optic connectors are supplied less termini. Order multi-mode termini by Amphenol part number designation as shown in the chart below. Consult Amphenol, Sidney, NY for further availability.

\* Indicated dimension when fully assembled.

\*\* Alignment sleeve shipped unassembled.

All dimensions for reference only.



# CF38999 Multi-Channel Connectors

## The Industry Standard for Fiber Optics



- Meets or exceeds MIL-DTL-38999 Series III requirements
- EMI Shielding-solid metal to metal coupling, grounding fingers, electroless nickel plating, and thicker wall sections provide superior EMI shielding capability of 65dB min. at 10 GHz.
- Termini Protection-recessed pins in this 100% scoop-proof connector minimize potential termini damage
- Corrosion Resistance-shells of stainless steel or cadmium over nickel plating withstand 500 hr. salt spray exposure
- Vibration/Shock-operates under severe high temperature vibration
- Threaded coupling quickly and completely mates in one 360° turn of the coupling nut

### Additional, composite connectors features include:

- Lightweight - 17%-70% weight savings
- Increased Corrosion Resistance-olive drab cadmium (175°C) and electroless nickel plating (200°C) both withstand 2000 hours of salt spray exposure.
- Durability-1500 couplings minimum (in reference to connector couplings, not termini)

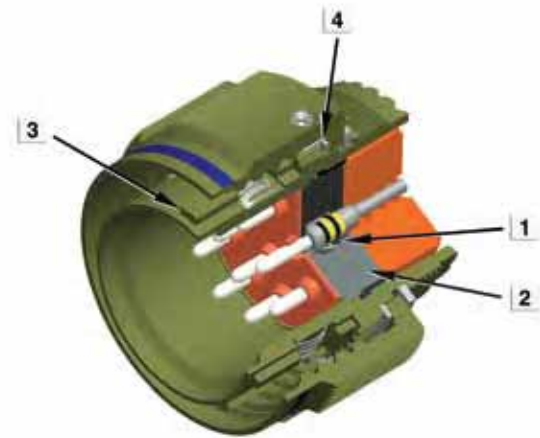

The illustration above shows the key features of the CF38999. The highest optical performance connector conforming to MIL-DTL-38999

1. Beryllium-copper retention clip for improved termini stability
2. Precision-aligned inserts
3. Modified master key
4. Integrated wave washer for improved performance in high vibration environments

### MECHANICAL/ENVIRONMENTAL

| PARAMETER         | PERFORMANCE  |
|-------------------|--|
| Maintenance Aging | MIL-STD-1344 Method 2002   |
| Mating Durability | 500 mating cycles  |
| Insert Retention  | 100 PSI/25 lbs minimum   |
| Sine Vibration    | 60 G (140-2000 Hz), 4 hours each at ambient, -55 deg C, and +175 deg C |
| Standard Shock    | 300 G half-sine, 3 ms duration   |
| High Impact Shock | MIL-S-901 grade A with lightweight fixture                             |
| Temperature Life  | 1000 hours @ high temp rating  |
| Thermal Shock     | -55° C to +165° C - 5 cycles   |

### MATERIALS & FINISH CHARACTERISTICS

| SHELL MATERIAL/FINISH                           | TEMPERATURE RATING (DEG C) | SALT SPRAY RATING (HOURS) | MIL-DTL-38999 SERVICE CLASS |
|---|----------------------------|---------------------------|-----------------------------|
| Aluminum/Durmalon                               | -65 to +175                | 500                       | T                           |
| Aluminum/electroless nickel                     | -65 to +200                | 500                       | F                           |
| Aluminum/olive drab cadmium plate nickel base   | -65 to +175                | 500                       | W                           |
| Stainless steel                                 | -65 to +200                | 500                       | K                           |
| Composite/electroless nickel                    | -65 to +200                | 2000                      | M                           |
| Composite/ olive drab cadmium plate nickel base | -65 to +175                | 2000                      | J                           |

38999  
III  
II  
I  
SJT

26482  
Matrix 2

83723 III  
Matrix  
Pyle

5015  
Crimp Rear  
Release Matrix

26500 Pyle

Printed  
Circuit Board

EMI Filter  
Transient

Fiber Optics

High Speed  
Contacts

Options  
Others

## Easy Steps to build a part number... Tri-Start Series III

| 1.             | 2.       | 3.     | 4.          | 5.                             | 6.                                 |
|----------------|----------|--------|-------------|--------------------------------|------------------------------------|
| Connector Type | Material | Finish | Shell Style | Shell Size- Insert Arrangement | Contact Type & Key/Keyway Position |
| CF-            | 50       | 9      | 0           | 17-08                          | P                                  |

Amphenol® Multi-Channel fiber optic connectors for use with multi-mode and single mode termini can be ordered by coded part number. Ordering procedure is illustrated by part number CF-509017-08P as shown above:

### Step 1. Select a Connector Type

|     | Designates   |
|-----|--|
| CF- | Multi-Channel Fiber Optic Connector  |
| DF- | Multi-Channel Fiber Optic Connector supplied per D38999 with sealing plugs and insertion/removal tools |

### Step 2. Select a Material

|    | Designates            |
|----|-----------------------|
| 50 | Aluminum shell        |
| 60 | Composite shell       |
| 80 | Stainless steel shell |

### Step 3. Select a Finish

|   | Designates   |
|---|--|
| 4 | Electroless nickel plated aluminum, 48 hour salt spray resistance, 200°C                     |
| 5 | Unplated composite   |
| 6 | Corrosion resistant stainless steel, 500 hour salt spray resistance, 200°C                   |
| 9 | Corrosion resistant olive drab cadmium plate aluminum, 500 hour salt spray resistance, 175°C |
| D | Designates Durmalon™ (Nickel-PTFE)*  |
| S | Nickel plated stainless steel  |

### Step 4. Select a Shell Style

|   | Designates                      |
|---|---------------------------------|
| 0 | Wall mount receptacle           |
| 1 | Line receptacle                 |
| 2 | Box mount receptacle            |
| 5 | Straight plug less ground strap |
| 6 | Straight plug                   |
| 7 | Jam nut receptacle              |

### Step 5. Select a Shell Size – Insert Arrangement from proceeding pages.

Shell size & Insert Arrangement are on page 347. First number represents Shell Size, second number is the Insert Arrangement.

### Step 6. Select a Contact Type & Key/Keyway Position

#### Contact Type and Key/Keyway Position

P designates pin contacts

S designates socket contacts

For key/keyway positioning, choose the alternate rotation suffix letter from the chart below.

#### ALTERNATE POSITION SUFFIX

| Alternate Position | Suffix Letter |         |
|--------------------|---------------|---------|
|                    | Pins          | Sockets |
| Normal             | P             | S       |
| A                  | G             | H       |
| B                  | I             | J       |
| C                  | K             | L       |
| D                  | M             | N       |
| E                  | R             | T       |

For more information on key/keyway rotation, see the Series III MIL-DTL-38999 Section.

38999  
SJT I II III

26482  
Matrix 2

83723 III  
Matrix Pyle

5015  
Crimp Rear Release Matrix

26500 Pyle

Printed  
Circuit Board

EMI Filter  
Transient

Fiber Optics

High Speed  
Contacts

Options  
Others

\*Durmalon is a trademark of Amphenol. For more information on Durmalon, go to [www.amphenol-aerospace.com/durmalon.asp](http://www.amphenol-aerospace.com/durmalon.asp)

# Multi-Channel Fiber Optic Circular Insert Availability, (CF38999) Type



Fiber optic termini can be accommodated in any size 16 or size 20 contact cavity of MIL-DTL-38999 Series III type connector insert patterns, as listed in the following chart. For availability of fiber type, either multi-mode or single mode, see note at bottom of chart.

| Shell Size/<br>Arrangement | Total<br>Contacts | Contact Size |                                |     |    |              |               |             |                    |
|----------------------------|-------------------|--------------|--------------------------------|-----|----|--------------|---------------|-------------|--------------------|
|                            |                   | 22D          | Optic Termini<br>Availability* |     | 12 | 12<br>(Coax) | 10<br>(Power) | 8<br>(Coax) | 8<br>(Twinax)<br>♦ |
|                            |                   |              | 20                             | 16  |    |              |               |             |                    |
| 09-94                      | 2                 |              | 2                              |     |    |              |               |             |                    |
| 09-98                      | 3                 |              | 3                              |     |    |              |               |             |                    |
| 11-02                      | 2                 |              |                                | 2   |    |              |               |             |                    |
| 11-05                      | 5                 |              | 5                              |     |    |              |               |             |                    |
| 11-98                      | 6                 |              | 6                              |     |    |              |               |             |                    |
| 11-99                      | 7                 |              | 7                              |     |    |              |               |             |                    |
| 13-04                      | 4                 |              |                                | 4   |    |              |               |             |                    |
| 13-08                      | 8                 |              | 8                              |     |    |              |               |             |                    |
| 13-13                      | 4                 |              |                                | 2** | 2  |              |               |             |                    |
| 13-98                      | 10                |              | 10                             |     |    |              |               |             |                    |
| 15-05                      | 5                 |              |                                | 5   |    |              |               |             |                    |
| 15-15                      | 15                |              | 14                             | 1   |    |              |               |             |                    |
| 15-18                      | 18                |              | 18                             |     |    |              |               |             |                    |
| 15-19                      | 19                |              | 19                             |     |    |              |               |             |                    |
| 15-97                      | 12                |              | 8                              | 4   |    |              |               |             |                    |
| 17-08                      | 8                 |              |                                | 8   |    |              |               |             |                    |
| 17-26                      | 26                |              | 26                             |     |    |              |               |             |                    |
| 17-99                      | 23                |              | 21                             | 2   |    |              |               |             |                    |
| 19-11                      | 11                |              |                                | 11  |    |              |               |             |                    |
| 19-28                      | 28                |              | 26                             | 2   |    |              |               |             |                    |
| 19-32                      | 32                |              | 32                             |     |    |              |               |             |                    |
| 21-16                      | 16                |              |                                | 16  |    |              |               |             |                    |
| 21-29                      | 27                |              | 19                             | 4   | 4  |              |               |             |                    |
| 21-39                      | 39                |              | 37                             | 2   |    |              |               |             |                    |
| 21-41                      | 41                |              | 41                             |     |    |              |               |             |                    |
| 23-21                      | 21                |              |                                | 21  |    |              |               |             |                    |
| 23-53                      | 53                |              | 53                             |     |    |              |               |             |                    |
| 23-54                      | 53                | 40           |                                | 9   | 4  |              |               |             |                    |
| 23-55                      | 55                |              | 55                             |     |    |              |               |             |                    |
| 25-04                      | 56                |              | 48                             | 8   |    |              |               |             |                    |
| 25-11***                   | 11                |              | 2                              |     |    | 9            |               |             |                    |
| 25-20***                   | 30                |              | 10                             | 13  |    | 4            |               |             | 3                  |
| 25-24                      | 24                |              |                                | 12  | 12 |              |               |             |                    |
| 25-26                      | 25                |              | 16                             |     | 5  |              |               | 4           |                    |
| 25-29                      | 29                |              |                                | 29  |    |              |               |             |                    |
| 25-37                      | 37                |              |                                | 37  |    |              |               |             |                    |
| 25-41                      | 41                | 22           | 3                              | 11  |    | 2            |               |             | 3                  |
| 25-43                      | 43                |              | 23                             | 20  |    |              |               |             |                    |
| 25-46                      | 46                |              | 40                             | 4   |    |              |               | 2†          |                    |
| 25-61                      | 61                |              | 61                             |     |    |              |               |             |                    |
| 25-90                      | 46                |              | 40                             | 4   |    |              |               |             | 2                  |
| 25-F4                      | 66                | 49           |                                | 13  | 4  |              |               |             |                    |

\* Size 16 multi-mode and single mode fiber optic termini are readily available. For size 20 multi-mode termini consult Amphenol Aerospace for availability.  
 \*\* Two size 16 contacts dedicated to fiber optics.  
 \*\*\* For use in MIL-STD-1760 applications. See 38999 Series III section in this catalog.  
 † For RG180/U and RG195/U cables only. Contact Amphenol for other cable applications.  
 F Size 8 coax and Twinax are interchangeable.  
 For service ratings and performance of electrical contacts see 38999 Series III section in this catalog.

38999  
III  
II  
I  
SJT

26482  
Matrix 2

83723 III  
Matrix  
Pyle

5015  
Crimp Rear  
Release Matrix

26500 Pyle

Printed  
Circuit Board

EMI Filter  
Transient

Fiber Optics

High Speed  
Contacts

Options  
Others

Front face of pin inserts illustrated



| Insert Arrangement | 09-94 | 09-98 | 11-02 | 11-05 | 11-98 | 11-99 | 13-04 | 13-08 |
|--------------------|-------|-------|-------|-------|-------|-------|-------|-------|
| Number of Contacts | 2     | 3     | 2     | 5     | 6     | 7     | 4     | 8     |
| Contact Size       | 20    | 20    | 16    | 20    | 20    | 20    | 16    | 20    |

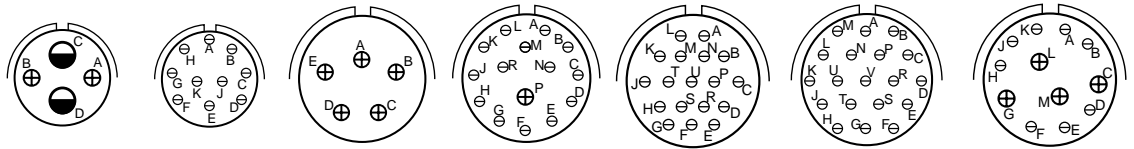

| Insert Arrangement | 13-13 | 13-98 | 15-05 | 15-15 | 15-18 | 15-19 | 15-97 |    |    |    |
|--------------------|-------|-------|-------|-------|-------|-------|-------|----|----|----|
| Number of Contacts | 2     | 2     | 10    | 5     | 14    | 1     | 18    | 19 | 8  | 4  |
| Contact Size       | 16    | 12    | 20    | 16    | 20    | 16    | 20    | 20 | 20 | 16 |

Dedicated to Fiber Optics

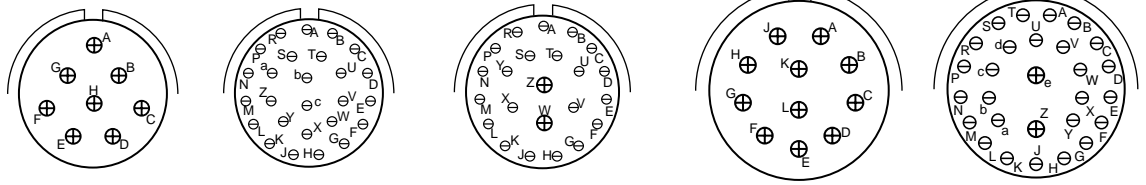

| Insert Arrangement | 17-08 | 17-26 | 17-99 | 19-11 | 19-28 |    |    |
|--------------------|-------|-------|-------|-------|-------|----|----|
| Number of Contacts | 2     | 26    | 21    | 2     | 11    | 26 | 2  |
| Contact Size       | 16    | 20    | 20    | 16    | 16    | 20 | 16 |

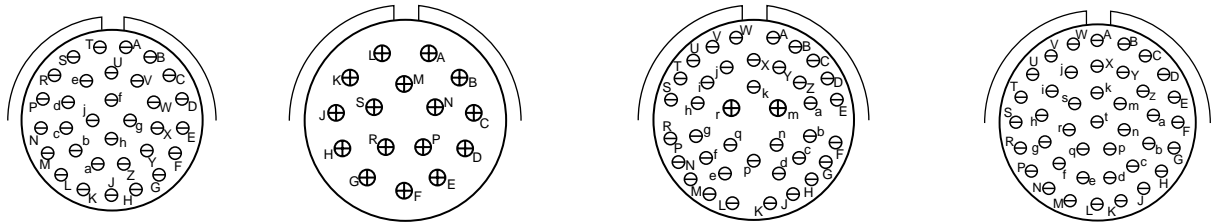

| Insert Arrangement | 19-32 | 21-16 | 21-39 | 21-41 |    |
|--------------------|-------|-------|-------|-------|----|
| Number of Contacts | 32    | 16    | 37    | 2     | 41 |
| Contact Size       | 20    | 16    | 20    | 16    | 20 |

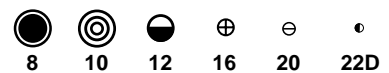

CONTACT LEGEND 8 10 12 16 20 22D

# Multi-Channel Fiber Optic Circular (CF38999) Insert Arrangements

Front face of pin inserts illustrated

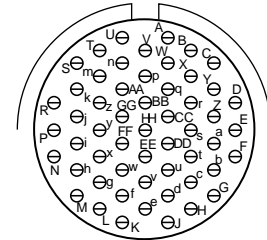
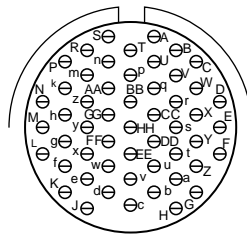
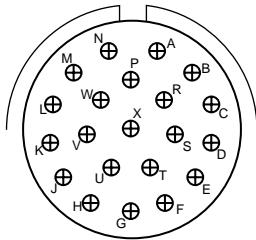

| Insert Arrangement | 23-21 | 23-53 | 23-55 |
|--------------------|-------|-------|-------|
| Number of Contacts | 21    | 53    | 55    |
| Contact Size       | 16    | 20    | 20    |

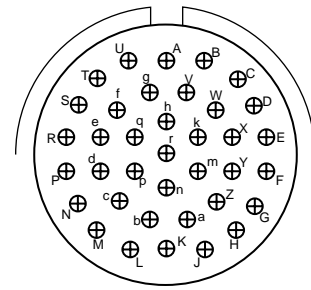
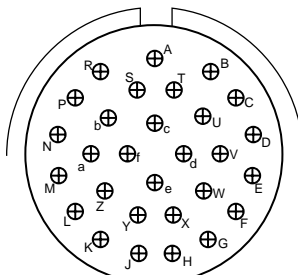
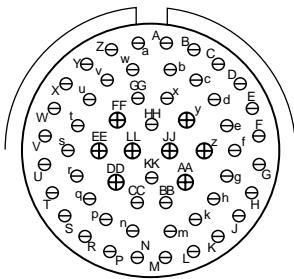

| Insert Arrangement | 25-04 | 25-29 | 25-37 |
|--------------------|-------|-------|-------|
| Number of Contacts | 48 6  | 29    | 37    |
| Contact Size       | 20 16 | 16    | 16    |

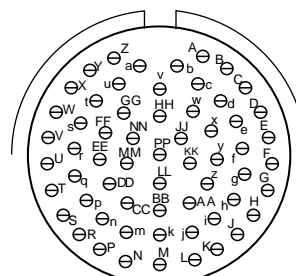
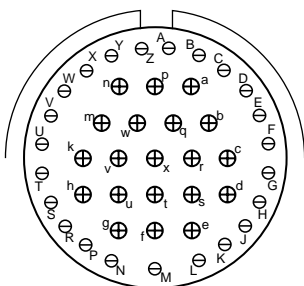

| Insert Arrangement | 25-43 | 25-61 |
|--------------------|-------|-------|
| Number of Contacts | 23 20 | 61    |
| Contact Size       | 20 16 | 20    |

\*\*\* For use in MIL-STD-1760 applications. See 38999 Series III section in this catalog.  
† 12 Coax Contacts can be Matched Impedance or Power

**CONTACT LEGEND**

|   |    |    |    |    |     |
|---|----|----|----|----|-----|
|   |    |    |    |    |     |
| 8 | 10 | 12 | 16 | 20 | 22D |

|     |       |          |           |                |            |               |            |              |            |         |
|-----|-------|----------|-----------|----------------|------------|---------------|------------|--------------|------------|---------|
| III | 38999 | 26482    | 83723 III | 5015           | 26500 Pyle | Printed       | EMI Filter | Fiber Optics | High Speed | Options |
| II  |       | Matrix 2 | Matrix    | Crimp Rear     |            | Circuit Board | Transient  |              | Contacts   | Others  |
| I   |       |          | Pyle      | Release Matrix |            |               |            |              |            |         |
| SJT |       |          |           |                |            |               |            |              |            |         |

### TRI-START™ METAL AND COMPOSITE CONNECTORS

#### Wall Mount Receptacle with Fiber Optics shell style 0

For complete part number, see how to order, page 346.

† Red Band indicates fully mated  
 †† Blue band indicates rear release contact retention system

□ Designates true position dimensioning

All dimensions for reference only

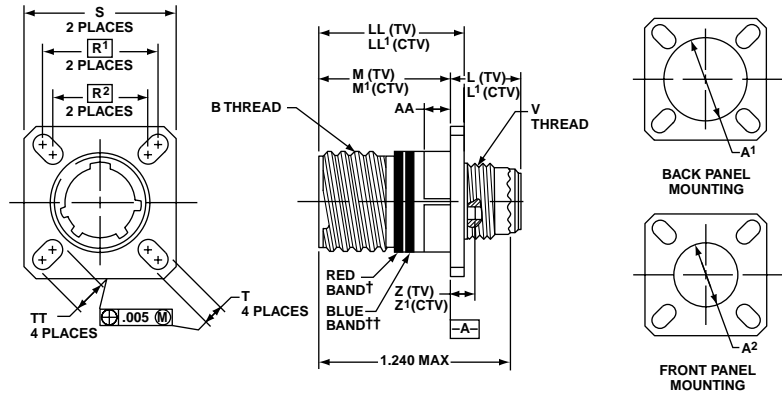

| Shell Size | MS Shell Size Code | BThread Class 2A 0.1P-0.3L-TS (Plated) | L Max. (TV) | L' Max. (CTV) | M +.000 - .005 (TV) | M' +.000 - .005 (CTV) | R <sup>1</sup> | R <sup>2</sup> | S Max. | T +.008 | V Thread Metric | Z Max. (TV) | Z' Max. (CTV) | A <sup>1</sup> Dia. Back Panel Mount | A <sup>2</sup> Dia. Front Panel Mount | AA Max. Panel Thickness | LL +.006 - .000 (TV) | LL' ±.005 (CTV) | TT ±.008 |
|------------|--------------------|--|-------------|---------------|---------------------|-----------------------|----------------|----------------|--------|---------|-----------------|-------------|---------------|--------------------------------------|---------------------------------------|-------------------------|----------------------|-----------------|----------|
| 9          | A                  | .6250                                  | .469        | .514          | .820                | .773                  | .719           | .594           | .948   | .128    | M12X1-6g        | .153        | .198          | .650                                 | .510                                  | .234                    | .905                 | .908            | .216     |
| 11         | B                  | .7500                                  | .469        | .514          | .820                | .773                  | .812           | .719           | 1.043  | .128    | M15X1-6g        | .153        | .198          | .800                                 | .620                                  | .234                    | .905                 | .908            | .194     |
| 13         | C                  | .8750                                  | .469        | .514          | .820                | .773                  | .906           | .812           | 1.137  | .128    | M18X1-6g        | .153        | .198          | .910                                 | .740                                  | .234                    | .905                 | .908            | .194     |
| 15         | D                  | 1.0000                                 | .469        | .514          | .820                | .773                  | .969           | .906           | 1.232  | .128    | M22X1-6g        | .153        | .198          | 1.040                                | .900                                  | .234                    | .905                 | .908            | .173     |
| 17         | E                  | 1.1875                                 | .469        | .514          | .820                | .773                  | 1.062          | .969           | 1.323  | .128    | M25X1-6g        | .153        | .198          | 1.210                                | 1.010                                 | .234                    | .905                 | .908            | .194     |
| 19         | F                  | 1.2500                                 | .469        | .514          | .820                | .773                  | 1.156          | 1.062          | 1.449  | .128    | M28X1-6g        | .153        | .198          | 1.280                                | 1.130                                 | .234                    | .905                 | .908            | .194     |
| 21         | G                  | 1.3750                                 | .500        | .545          | .790                | .741                  | 1.250          | 1.156          | 1.575  | .128    | M31X1-6g        | .183        | .228          | 1.410                                | 1.250                                 | .204                    | .905                 | .904            | .194     |
| 23         | H                  | 1.5000                                 | .500        | .545          | .790                | .741                  | 1.375          | 1.250          | 1.701  | .154    | M34X1-6g        | .183        | .228          | 1.530                                | 1.360                                 | .204                    | .905                 | .904            | .242     |
| 25         | J                  | 1.6250                                 | .500        | .545          | .790                | .741                  | 1.500          | 1.375          | 1.823  | .154    | M37X1-6g        | .183        | .228          | 1.660                                | 1.470                                 | .204                    | .905                 | .904            | .242     |

#### Box Mount Receptacle with Fiber Optics shell style 2

For complete part number, see how to order, page 346.  
 Consult Amphenol Aerospace for availability of composite box mount receptacles.

† Red Band indicates fully mated  
 †† Blue band indicates rear release contact retention system

□ Designates true position dimensioning

All dimensions for reference only

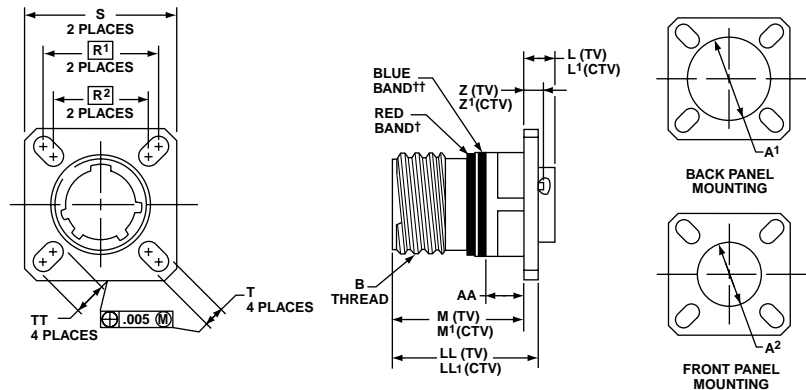

| Shell Size | MS Shell Size Code | BThread Class 2A 0.1P-0.3L-TS (Plated) | L Max. (TV) | L' Max. (CTV) | M +.000 - .005 (TV) | M' +.000 - .005 (CTV) | R <sup>1</sup> | R <sup>2</sup> | S Max. | T +.008 | Z Max. (TV) | Z' Max. (CTV) | A <sup>1</sup> Dia. Back Panel Mount | A <sup>2</sup> Dia. Front Panel Mount | AA Max. Panel Thickness | LL +.006 - .000 (TV) | LL' ±.005 (CTV) | TT ±.008 |
|------------|--------------------|--|-------------|---------------|---------------------|-----------------------|----------------|----------------|--------|---------|-------------|---------------|--------------------------------------|---------------------------------------|-------------------------|----------------------|-----------------|----------|
| 9          | A                  | .6250                                  | .205        | .250          | .820                | .773                  | .719           | .594           | .948   | .128    | .153        | .198          | .650                                 | .510                                  | .234                    | .905                 | .908            | .216     |
| 11         | B                  | .7500                                  | .205        | .250          | .820                | .773                  | .812           | .719           | 1.043  | .128    | .153        | .198          | .800                                 | .620                                  | .234                    | .905                 | .908            | .194     |
| 13         | C                  | .8750                                  | .205        | .250          | .820                | .773                  | .906           | .812           | 1.137  | .128    | .153        | .198          | .910                                 | .740                                  | .234                    | .905                 | .908            | .194     |
| 15         | D                  | 1.0000                                 | .205        | .250          | .820                | .773                  | .969           | .906           | 1.232  | .128    | .153        | .198          | 1.040                                | .900                                  | .234                    | .905                 | .908            | .173     |
| 17         | E                  | 1.1875                                 | .205        | .250          | .820                | .773                  | 1.062          | .969           | 1.323  | .128    | .153        | .198          | 1.210                                | 1.010                                 | .234                    | .905                 | .908            | .194     |
| 19         | F                  | 1.2500                                 | .205        | .250          | .820                | .773                  | 1.156          | 1.062          | 1.449  | .128    | .153        | .198          | 1.280                                | 1.130                                 | .234                    | .905                 | .908            | .194     |
| 21         | G                  | 1.3750                                 | .235        | .280          | .790                | .741                  | 1.250          | 1.156          | 1.575  | .128    | .183        | .228          | 1.410                                | 1.250                                 | .204                    | .905                 | .904            | .194     |
| 23         | H                  | 1.5000                                 | .235        | .280          | .790                | .741                  | 1.375          | 1.250          | 1.701  | .154    | .183        | .228          | 1.530                                | 1.360                                 | .204                    | .905                 | .904            | .242     |
| 25         | J                  | 1.6250                                 | .235        | .280          | .790                | .741                  | 1.500          | 1.375          | 1.823  | .154    | .183        | .228          | 1.660                                | 1.470                                 | .204                    | .905                 | .904            | .242     |

38999  
SJT I II III

26482  
Matrix 2

83723 III  
Matrix Pyle

5015  
Crimp Rear Release Matrix

26500 Pyle

Printed  
Circuit Board

EMI Filter  
Transient

Fiber Optics

High Speed  
Contacts

Options  
Others



## TRI-START™ METAL AND COMPOSITE CONNECTORS

### Jam Nut Receptacle with Fiber Optics shell style 7

For complete part number, see how to order, page 346.

† Red Band indicates fully mated  
†† Blue band indicates rear release contact retention system

★ .059 dia. min. 3 lockwire holes  
Formed lockwire hole design (6 holes) is optional  
All dimensions for reference only

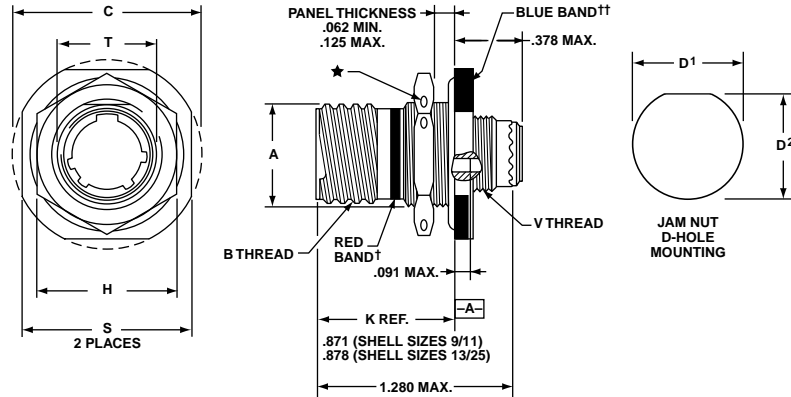

| Shell Size | MS Shell Size Code | A •<br>+0.00<br>-0.010 | B Thread<br>Class 2A<br>0.1P-0.3L-TS (Plated) | C<br>Max. | D <sup>1</sup><br>+0.01<br>-0.000 | D <sup>2</sup><br>+0.00<br>-0.010 | H Hex<br>+0.017<br>-0.016 | S<br>±0.010 | T<br>+0.01<br>-0.000 | V<br>Thread<br>Metric |
|------------|--------------------|------------------------|---|-----------|-----------------------------------|-----------------------------------|---------------------------|-------------|----------------------|-----------------------|
| 9          | A                  | .669                   | .6250   | 1.199     | .700                              | .670                              | .875                      | 1.062       | .697                 | M12X1-6g              |
| 11         | B                  | .769                   | .7500   | 1.386     | .825                              | .770                              | 1.000                     | 1.250       | .822                 | M15X1-6g              |
| 13         | C                  | .955                   | .8750   | 1.511     | 1.010                             | .955                              | 1.188                     | 1.375       | 1.007                | M18X1-6g              |
| 15         | D                  | 1.084                  | 1.0000  | 1.636     | 1.135                             | 1.085                             | 1.312                     | 1.500       | 1.134                | M22X1-6g              |
| 17         | E                  | 1.208                  | 1.1875  | 1.761     | 1.260                             | 1.210                             | 1.438                     | 1.625       | 1.259                | M25X1-6g              |
| 19         | F                  | 1.333                  | 1.2500  | 1.949     | 1.385                             | 1.335                             | 1.562                     | 1.812       | 1.384                | M28X1-6g              |
| 21         | G                  | 1.459                  | 1.3750  | 2.073     | 1.510                             | 1.460                             | 1.688                     | 1.938       | 1.507                | M31X1-6g              |
| 23         | H                  | 1.575                  | 1.5000  | 2.199     | 1.635                             | 1.585                             | 1.812                     | 2.062       | 1.634                | M34X1-6g              |
| 25         | J                  | 1.709                  | 1.6250  | 2.323     | 1.760                             | 1.710                             | 2.000                     | 2.188       | 1.759                | M37X1-6g              |

### Line Receptacle with Fiber Optics shell style 1

For complete part number, see how to order, page 346.

† Red Band indicates fully mated  
†† Blue band indicates rear release contact retention system  
All dimensions for reference only

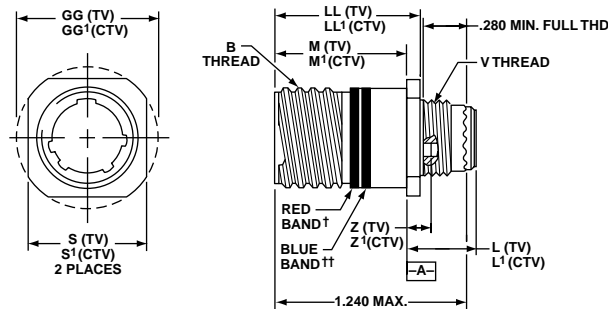

| Shell Size | MS Shell Size Code | B Thread<br>0.1P-0.3L-TS-2A<br>(Plated) | L<br>Max.<br>(TV) | L <sup>1</sup><br>Max.<br>(CTV) | M<br>+0.00<br>-0.005<br>(TV) | M <sup>1</sup><br>+0.00<br>-0.005<br>(CTV) | S<br>±0.010<br>(TV) | S <sup>1</sup><br>±0.010<br>(CTV) | V<br>Thread<br>Metric | Z<br>Max.<br>(TV) | Z <sup>1</sup><br>Max.<br>(CTV) | GG<br>Dia.<br>±0.010<br>(TV) | GG <sup>1</sup><br>Dia.<br>±0.010<br>-0.000<br>(CTV) | LL<br>+0.006<br>-0.000<br>(TV) | LL <sup>1</sup><br>±0.005<br>(CTV) |
|------------|--------------------|---|-------------------|---------------------------------|------------------------------|--|---------------------|-----------------------------------|-----------------------|-------------------|---------------------------------|------------------------------|--|--------------------------------|------------------------------------|
| 9          | A                  | .6250                                   | .469              | .514                            | .820                         | .773                                       | .675                | .635                              | M12X1-6g              | .153              | .198                            | .812                         | .699   | .905                           | .908                               |
| 11         | B                  | .7500                                   | .469              | .514                            | .820                         | .773                                       | .800                | .765                              | M15X1-6g              | .153              | .198                            | .905                         | .875   | .905                           | .908                               |
| 13         | C                  | .8750                                   | .469              | .514                            | .820                         | .773                                       | .925                | .885                              | M18X1-6g              | .153              | .198                            | 1.093                        | 1.007  | .905                           | .908                               |
| 15         | D                  | 1.0000                                  | .469              | .514                            | .820                         | .773                                       | 1.050               | 1.100                             | M22X1-6g              | .153              | .198                            | 1.219                        | 1.140  | .905                           | .908                               |
| 17         | E                  | 1.1875                                  | .469              | .514                            | .820                         | .773                                       | 1.238               | 1.197                             | M25X1-6g              | .153              | .198                            | 1.375                        | 1.229  | .905                           | .908                               |
| 19         | F                  | 1.2500                                  | .469              | .514                            | .820                         | .773                                       | 1.300               | 1.260                             | M28X1-6g              | .153              | .198                            | 1.469                        | 1.380  | .905                           | .908                               |
| 21         | G                  | 1.3750                                  | .500              | .545                            | .790                         | .741                                       | 1.425               | 1.385                             | M31X1-6g              | .183              | .228                            | 1.625                        | 1.493  | .905                           | .904                               |
| 23         | H                  | 1.5000                                  | .500              | .545                            | .790                         | .741                                       | 1.550               | 1.510                             | M34X1-6g              | .183              | .228                            | 1.750                        | 1.626  | .905                           | .904                               |
| 25         | J                  | 1.6250                                  | .500              | .545                            | .790                         | .741                                       | 1.675               | 1.635                             | M37X1-6g              | .183              | .228                            | 1.875                        | 1.777  | .905                           | .904                               |

III  
II  
I  
SJT  
38999

Matrix 2  
26482

Matrix  
Pyle  
83723 III

Release Matrix  
Crimp Rear  
5015

26500 Pyle

Printed  
Circuit Board

EM1 Filter  
Transient

Fiber Optics

High Speed  
Contacts

Options  
Others

**TRI-START™ METAL AND COMPOSITE CONNECTORS**

**Straight Plug with Fiber Optics  
shell style 6**

For complete part number,  
see how to order, page 346.

METAL

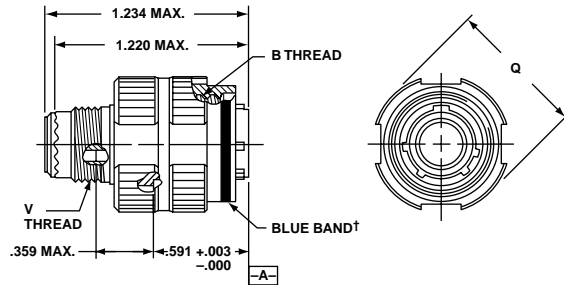

COMPOSITE

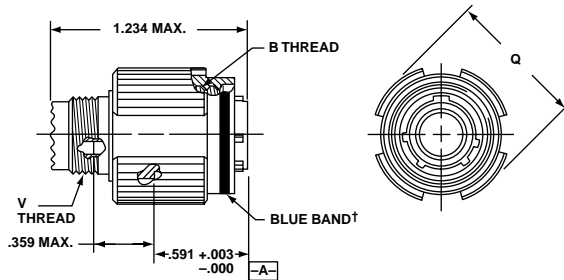

† Blue band indicates rear release contact retention system

**Straight Plug**

| Shell Size | MS Shell Size Code | BThread<br>0.1P-0.3L-TS-2B<br>(Plated) | Q Dia.<br>Max. | VThread<br>Metric |
|------------|--------------------|--|----------------|-------------------|
| 9          | A                  | .6250                                  | .858           | M12X1-6g          |
| 11         | B                  | .7500                                  | .984           | M15X1-6g          |
| 13         | C                  | .8750                                  | 1.157          | M18X1-6g          |
| 15         | D                  | 1.0000                                 | 1.280          | M22X1-6g          |
| 17         | E                  | 1.1875                                 | 1.406          | M25X1-6g          |
| 19         | F                  | 1.2500                                 | 1.516          | M28X1-6g          |
| 21         | G                  | 1.3750                                 | 1.642          | M31X1-6g          |
| 23         | H                  | 1.5000                                 | 1.768          | M34X1-6g          |
| 25         | J                  | 1.6250                                 | 1.890          | M37X1-6g          |

38999  
SJT I II III

26482  
Matrix 2

83723 III  
Matrix Pyle

5015  
Crimp Rear Release Matrix

26500 Pyle

Printed  
Circuit Board

EMI Filter  
Transient

Fiber Optics

High Speed  
Contacts

Options  
Others



### HOW TO ORDER

#### Fiber Optic Pin Ordering Information

|          | Amphenol Part No. | Fiber Size Core/Cladding | A Dia. Ref. (Microns) | Ferrule Hole Tolerance |
|----------|-------------------|--------------------------|-----------------------|------------------------|
| JSFC18-1 | CF-198142-25A     | 9/125                    | 125.5                 | +1,-0                  |
| JSFC18-2 | CF-198142-126     | 50/125                   | 126                   | +1,-0                  |
| JSFC18-3 | CF-198142-053     | 200/230                  | 236                   | +4,-0                  |

#### Fiber Optic Socket Ordering Information

|          | Amphenol Part No. | Fiber Size Core/Cladding | A Dia. Ref. (Microns) | Ferrule Hole Tolerance |
|----------|-------------------|--------------------------|-----------------------|------------------------|
| JSFC17-1 | CF-198143-25A     | 9/125                    | 125.5                 | +1,-0                  |
| JSFC17-2 | CF-198143-126     | 50/125                   | 126                   | +1,-0                  |
| JSFC17-3 | CF-198143-053     | 200/230                  | 236                   | +4,-0                  |

### CF-198142-XXX JSFC18-X

Size 16 Pin Terminus

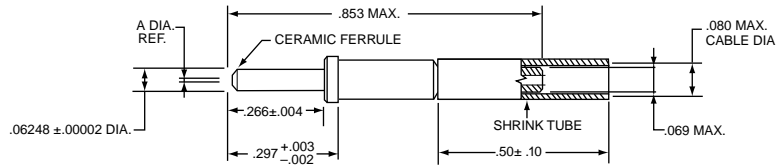

### CF-198143-XXX JSFC17-X

Size 16 Socket Terminus

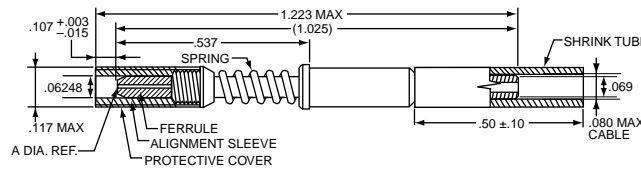

- Approved for use in JSF/F35 applications
- Precision ceramic ferrules which precisely position the fiber within the termini
- Precision ceramic alignment sleeves insure accurate fiber to fiber alignment
- Socket has threaded protective shroud with anti-rotation key, manufactured from rugged PEEK™ material, provides protection for the ceramic alignment sleeve
- Stainless steel termini bodies and springs

### MECHANICAL/ENVIRONMENTAL

| PARAMETER                         | PERFORMANCE                         |
|-----------------------------------|-------------------------------------|
| CABLE PULL OUT FORCE              | 22 lbs for 1 minute                 |
| MATING DURABILITY                 | 500 cycles                          |
| SHOCK – HIGH IMPACT               | MIL-S-901 Grade A, Type B, Class I  |
| SHOCK – HALF SINE PULSE           | 300 g, 3 ms duration                |
| VIBRATION - SINE                  | 60 g, 36 cycles                     |
| VIBRATION - RANDOM                | 49.5 g rms                          |
| VIBRATION – RANDOM AT TEMPERATURE | 41.7 g rms @ 125 deg C              |
| SALT SPRAY                        | 48 hours direct exposure @ 35 deg C |
| THERMAL SHOCK                     | -55 deg C to +165 deg C, 5 cycles   |
| TEMPERATURE LIFE                  | 165 deg C for 1000 hours            |

### MATERIALS LIST

| COMPONENT               | MATERIAL                   |
|-------------------------|----------------------------|
| Ferrule                 | Zirconia                   |
| Alignment sleeve        | Zirconia                   |
| Termini body            | Stainless Steel – AMS 5514 |
| Spring                  | Stainless Steel – AMS 5678 |
| Alignment sleeve shroud | PEEK™                      |
| Heat shrink             | Kynar, MIL-I-23053/8       |



38999  
III II I SJT

26482  
Matrix 2

83723 III  
Matrix Pyle

5015  
Crimp Rear Release Matrix

26500 Pyle

Printed  
Circuit Board

EMI Filter  
Transient

Fiber Optics

High Speed  
Contacts

Options  
Others



- Approved for use in JSF/F35 applications
- Based on Amphenol® Composite Tri-Start, Qualified to MIL-DTL-38999, Rev. J.
- Increased Corrosion Resistance-nickel plating (200°C) both with stand 2000 hours of salt spray exposure.
- Durability-1500 couplings minimum (in reference to connector couplings, not termini)
- Termini Protection-recessed pins in this 100% scoop-proof connector minimize potential termini damage
- Vibration/Shock-operates under severe high temperature vibration
- Threaded coupling quickly and completely mates in one 360° turn of the coupling nut

### JSFC 15 Fiber Optic Receptacle

### JSFC 16 Fiber Optic Plug



#### MECHANICAL/ENVIRONMENTAL

| PARAMETER         | PERFORMANCE  |
|-------------------|--|
| Maintenance Aging | MIL-STD-1344 Method 2002   |
| Mating Durability | 500 mating cycles  |
| Insert Retention  | 100 PSI/25 lbs minimum   |
| Sine Vibration    | 60 G (140-2000 Hz), 4 hours each at ambient, -55 deg C, and +175 deg C |
| Standard Shock    | 300 G half-sine, 3 ms duration   |
| High Impact Shock | MIL-S-901 grade A with lightweight fixture                             |
| Temperature Life  | 1000 hours @ high temp rating  |
| Thermal Shock     | -55° C to +165° C - 5 cycles   |

### Easy Steps to build a part number... JSFC15 & JSFC16

| 1. Program Part Number | 2. Shell Styles | 3. Service Class | 4. Shell Size – Insert arrangement | 5. Contact Type | 6. Alternate Positions |
|------------------------|-----------------|------------------|------------------------------------|-----------------|------------------------|
| JSFC15                 | 20              | M                | E – 8                              | A               | N                      |
| JSFC16                 | 26              | M                | E – 8                              | B               | N                      |

#### Step 1. Select a Connector Type

|        | Designates                      |
|--------|---------------------------------|
| JSFC15 | Receptacle circular fiber optic |
| JSFC16 | Plug circular fiber optic       |

#### Step 2. Select a Shell Style

|    | Designates                   |
|----|------------------------------|
| 20 | JSFC15 Wall Mount Receptacle |
| 26 | JSFC16 Straight Plug         |

#### Step 3. Select a Service Class

|   | Designates                          |
|---|-------------------------------------|
| M | Composite, electroless nickel plate |

#### Step 4. Select a Shell Size – Insert Arrangement

Shell Sizes are MIL-DTL-38999, Series III, plus newer High Density insert Arrangements

| Shell Size | Insert Arrangement | Shell Size | Insert Arrangement |
|------------|--------------------|------------|--------------------|
| B – (11)   | 2                  | F – (19)   | 11                 |
| C – (13)   | 4                  | G – (21)   | 16                 |
| D – (15)   | 5                  | H – (23)   | 21                 |
| E – (17)   | 8                  | J – (25)   | 29                 |
|            |                    | J – (25)   | 37                 |

#### Step 5. Select a Contact Type

|   | Designates      |
|---|-----------------|
| A | Pin contacts    |
| B | Socket contacts |

#### Step 6. Select an Alternate Position

A, B, C, D, E, N for normal

# JSFC 15 Fiber Optic Receptacle JSFC 16 Fiber Optic Plug

## JSFC15 Wall Mount Receptacle with Fiber Optics Shell Style 20

For complete part number see  
how to order, page 354

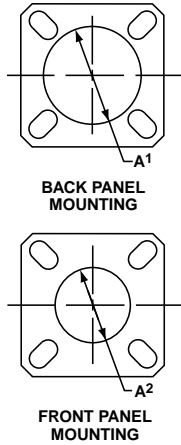
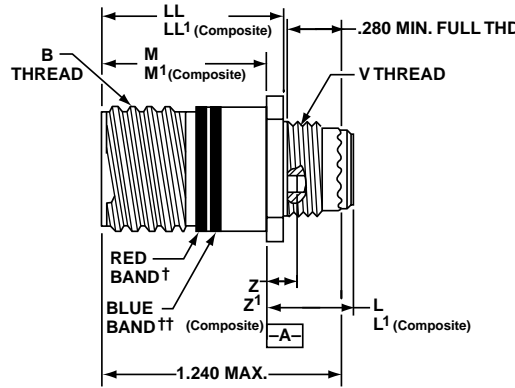
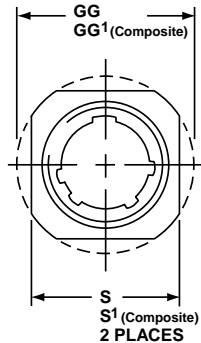

† Red Band indicates fully mated  
†† Blue band indicates rear release contact  
retention system

□ Designates true position dimensioning

All dimensions for reference only

| Shell Size | MS Shell Size Code | BThread Class 2A 0.1P-0.3L-TS (Plated) | L Max. (TV) | L' Max. (CTV) | M +.000 - .005 (TV) | M' +.000 - .005 (CTV) | R <sup>1</sup> | R <sup>2</sup> | S Max. | T +.008 | V Thread Metric | Z Max. (TV) | Z' Max. (CTV) | A <sup>1</sup> Dia. Back Panel Mount | A <sup>2</sup> Dia. Front Panel Mount | AA Max. Panel Thickness | LL +.006 - .000 (TV) | LL' ±.005 (CTV) | TT ±.008 |
|------------|--------------------|--|-------------|---------------|---------------------|-----------------------|----------------|----------------|--------|---------|-----------------|-------------|---------------|--------------------------------------|---------------------------------------|-------------------------|----------------------|-----------------|----------|
| 9          | A                  | .6250                                  | .469        | .514          | .820                | .773                  | .719           | .594           | .948   | .128    | M12X1-6g        | .153        | .198          | .650                                 | .510                                  | .234                    | .905                 | .908            | .216     |
| 11         | B                  | .7500                                  | .469        | .514          | .820                | .773                  | .812           | .719           | 1.043  | .128    | M15X1-6g        | .153        | .198          | .800                                 | .620                                  | .234                    | .905                 | .908            | .194     |
| 13         | C                  | .8750                                  | .469        | .514          | .820                | .773                  | .906           | .812           | 1.137  | .128    | M18X1-6g        | .153        | .198          | .910                                 | .740                                  | .234                    | .905                 | .908            | .194     |
| 15         | D                  | 1.0000                                 | .469        | .514          | .820                | .773                  | .969           | .906           | 1.232  | .128    | M22X1-6g        | .153        | .198          | 1.040                                | .900                                  | .234                    | .905                 | .908            | .173     |
| 17         | E                  | 1.1875                                 | .469        | .514          | .820                | .773                  | 1.062          | .969           | 1.323  | .128    | M25X1-6g        | .153        | .198          | 1.210                                | 1.010                                 | .234                    | .905                 | .908            | .194     |
| 19         | F                  | 1.2500                                 | .469        | .514          | .820                | .773                  | 1.156          | 1.062          | 1.449  | .128    | M28X1-6g        | .153        | .198          | 1.280                                | 1.130                                 | .234                    | .905                 | .908            | .194     |
| 21         | G                  | 1.3750                                 | .500        | .545          | .790                | .741                  | 1.250          | 1.156          | 1.575  | .128    | M31X1-6g        | .183        | .228          | 1.410                                | 1.250                                 | .204                    | .905                 | .904            | .194     |
| 23         | H                  | 1.5000                                 | .500        | .545          | .790                | .741                  | 1.375          | 1.250          | 1.701  | .154    | M34X1-6g        | .183        | .228          | 1.530                                | 1.360                                 | .204                    | .905                 | .904            | .242     |
| 25         | J                  | 1.6250                                 | .500        | .545          | .790                | .741                  | 1.500          | 1.375          | 1.823  | .154    | M37X1-6g        | .183        | .228          | 1.660                                | 1.470                                 | .204                    | .905                 | .904            | .242     |

## JSFC16 Straight Plug with Fiber Optics Shell Style 26

For complete part number see  
how to order, page 354

### COMPOSITE

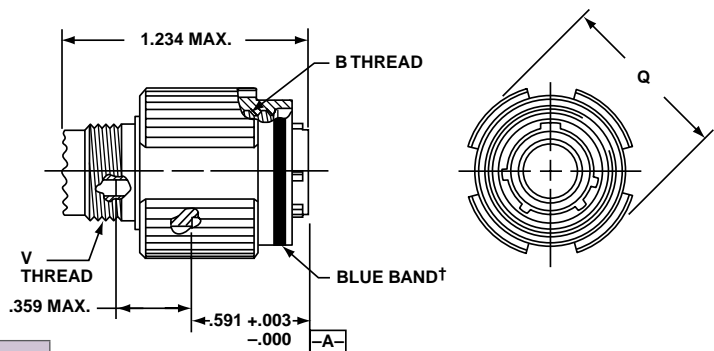

† Blue band indicates rear release contact  
retention system

All dimensions for reference only

| Shell Size | MS Shell Size Code | BThread 0.1P-0.3L-TS-2B (Plated) | Q Dia. Max. | VThread Metric |
|------------|--------------------|----------------------------------|-------------|----------------|
| 9          | A                  | .6250                            | .858        | M12X1-6g       |
| 11         | B                  | .7500                            | .984        | M15X1-6g       |
| 13         | C                  | .8750                            | 1.157       | M18X1-6g       |
| 15         | D                  | 1.0000                           | 1.280       | M22X1-6g       |
| 17         | E                  | 1.1875                           | 1.406       | M25X1-6g       |
| 19         | F                  | 1.2500                           | 1.516       | M28X1-6g       |
| 21         | G                  | 1.3750                           | 1.642       | M31X1-6g       |
| 23         | H                  | 1.5000                           | 1.768       | M34X1-6g       |
| 25         | J                  | 1.6250                           | 1.890       | M37X1-6g       |

III 38999  
II 1 SJT  
I Matrix 2  
Matrix 83723 III  
Pyle  
Release Matrix 5015  
Crimp Rear  
Release Matrix 26500 Pyle  
Printed  
Circuit Board  
EM1 Filter  
Transient  
Fiber Optics  
High Speed  
Contacts  
Options  
Others



**ARINC 801 Termini**

Designed for use in ARINC 801 Fiber Optic Connectors

**Amphenol® ARINC 801 Termini Features:**

- Designed for use in Amphenol ARINC 801 fiber optic connectors - manufactured to comply with ARINC 801.
- Genderless terminus allows for use on both sides of a connector
- Alignment sleeves are contained in a separate carrier which is removable for easier end-face cleaning
- Precision ceramic ferrules and sleeves ensure accurate fiber to fiber alignment
- Keyed to provide anti-rotation
- Available with both PC and APC end-face finishes
- Terminus body is crimped to the cable providing a "Pull-Proof" advantage

Amphenol ARINC fiber optic connectors are supplied less contacts. Order ARINC 801 termini by Amphenol part number designation as shown in the chart at right. Consult Amphenol, Sidney, NY for further availability.

See page 357 for information on ARINC 801 termini in circular 38999 connectors.

**HOW TO ORDER**

**Ordering Information**  
**ARINC 801 Termini for ARINC 801 Connectors**

| Amphenol ARINC 801 Termini Part Number | A Dia. Ref | Ferrule Hole Tolerance |
|--|------------|------------------------|
| CF-198148-125                          | 125        | +1, -0                 |
| CF-198148-129                          | 125.5      | +1, -0                 |
| CF-198148-126                          | 126        | +1, -0                 |
| CF-198148-128                          | 128        | +2, -0                 |
| CF-198148-144                          | 144        | +4, -0                 |
| CF-198148-157                          | 157        | +7, -0                 |
| CF-198148-175                          | 175        | +7, -0                 |
| CF-198148-236                          | 236        | +7, -0                 |
| CF-198148-336                          | 336        | +7, -0                 |
| CF-198148-448                          | 448        | +7, -0                 |

**ARINC 801 Termini**

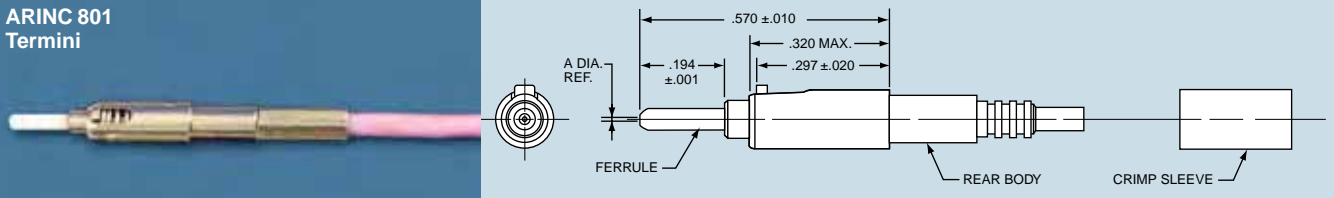

All dimensions for reference only.

38999  
SJT I II III

26482  
Matrix 2

83723 III  
Matrix Pyle

5015  
Crimp Rear Release Matrix

26500 Pyle

Printed  
Circuit Board

EMI Filter  
Transient

Fiber Optics

High Speed  
Contacts

Options  
Others



# Multi-Channel Fiber Optic Circular ARINC 801 Connectors



**ARINC 801 Inserts within  
Tri-Start Connectors**

## HOW TO ORDER ARINC 801 Connectors

| ARINC 801 Shell Style | Amphenol Part Number   |                    |                     |                          |
|-----------------------|------------------------|--------------------|---------------------|--------------------------|
|                       | Material/Finish        |                    |                     |                          |
|                       | Aluminum/Black Anodize | Composite/Unplated | Aluminum/OD Cadmium | Stainless Steel/Unplated |
| Straight Plug         | CF-97017X-YYs          | CF-97065X-YYs      | CF-97023X-YYs       | CF-97061X-YYs            |
| Wall Mount Receptacle | CF-97016X-YYp          | CF-97066X-YYp      | CF-97022X-YYp       | CF-97063X-YYp            |
| Jam Nut Receptacle    | CF-97030x-YYp          | CF-97064X-YYp      | CF-97031X-YYp       | CF-97060X-YYp            |

### Amphenol® ARINC 801 Connector:

Amphenol now offers a multi-channel circular connector that complies with the ARINC specification. This connector, available in straight plug and wall mount receptacle, uses the ARINC 801 ceramic termini described on page 356.

The features of the ARINC 801 connector include:

- Uses precision ARINC 801 fiber optic termini (typical multi-mode insertion loss is less than 0.15 dB).
- Removable alignment sleeve insert for easy cleaning of fiber optic termini.
- Three stages of alignment: shell-to-shell keys, guide pins and ceramic alignment sleeves.
- Includes all of the features of standard D38999 straight plug and wall mount receptacle shells (refer to page 350 for shell dimensions).
  - Scoop-proof design
  - Option for alternate keys and keyways
  - Rear accessory threads
  - Standard insertion/extraction tools (M81969/14-03)

| Shell Size          | Insert Arrangements |    |    |    |    |    |    |    |
|---------------------|---------------------|----|----|----|----|----|----|----|
|                     | 11                  | 13 | 15 | 17 | 19 | 21 | 23 | 25 |
| 'X' in part number  | 2                   | 3  | 4  | 5  | 6  | 7  | 8  | 9  |
| 'YY' in part number | 02                  | 04 | 06 | 08 | 12 | 16 | 24 | 32 |

Front face of pin inserts illustrated



Insert Arrangement 11-02

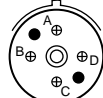

13-04

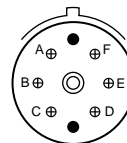

15-06

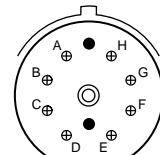

17-08

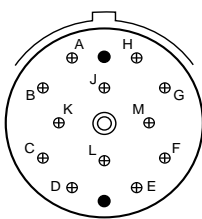

Insert Arrangement 19-12

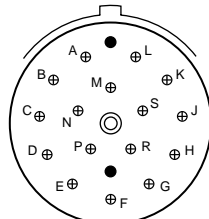

21-16

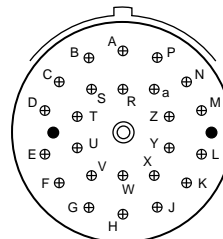

23-24

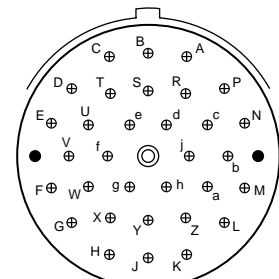

25-32

38999 III  
SJT

26482 Matrix 2

83723 III Matrix Pyle

5015 Crimp Rear Release Matrix

26500 Pyle

Printed Circuit Board

EMI Filter Transient

Fiber Optics

High Speed Contacts

Options Others



**MT Ferrule Fiber Optic Termini**

Designed for use in  
MT38999 Connectors

| <b>HOW TO ORDER</b>  |               |
|--|---------------|
| <b>Ordering Information for MT Assembly Kits and Tools</b> |               |
| MT Male Assembly Kit (flat ribbon)**                       | CF-198136-000 |
| MT Female Assembly (flat ribbon)**                         | CF-198137-000 |
| MT Male Assembly Kit (round cable)**                       | CF-198160-000 |
| MT Female Assembly Kit (round cable)**                     | CF-198161-000 |
| MT Kit Assembly Tool                                       | 11-100000-000 |
| MT Contact Removal Tool                                    | CF-008025-000 |

\*\* MT ferrules are not included in the assembly kits

**Amphenol® MT (Multi-terminal) Features:**

- Designed for use in Amphenol® MT38999 circular connectors and also for rectangular products: printed circuit board interconnects, LRM, VME64 and VITA46 interconnects.
- Male and female ferrules available in either multi-mode or single mode designs.
- Very high density can be achieved in cylindrical connectors:
  - Up to 24 fiber channels in a size 11 composite shell
  - Up to 96 fiber channels in a size 21 composite shell
- Amphenol supplies MT termini assemblies in kits, minus the MT ferrule. MT ferrules that meet the IEC1754-5 specification are recommended for use.
- Assembly tool 11-100000-000 is recommended for MT termini assembly into connectors; MT contact removal tool CF-008025-000 is also available.

**Amphenol® MT Termini Assembly Kit**  
(MT female socket clamp shown)

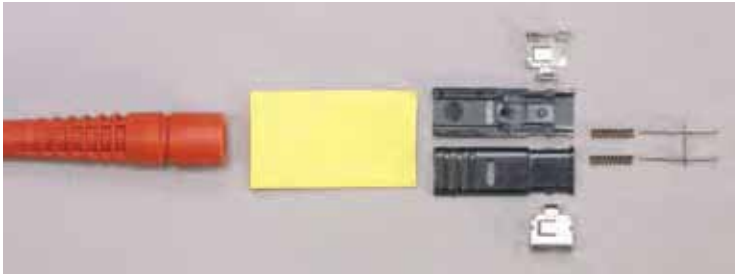

**MT Assembly Tool (11-100000-000)**

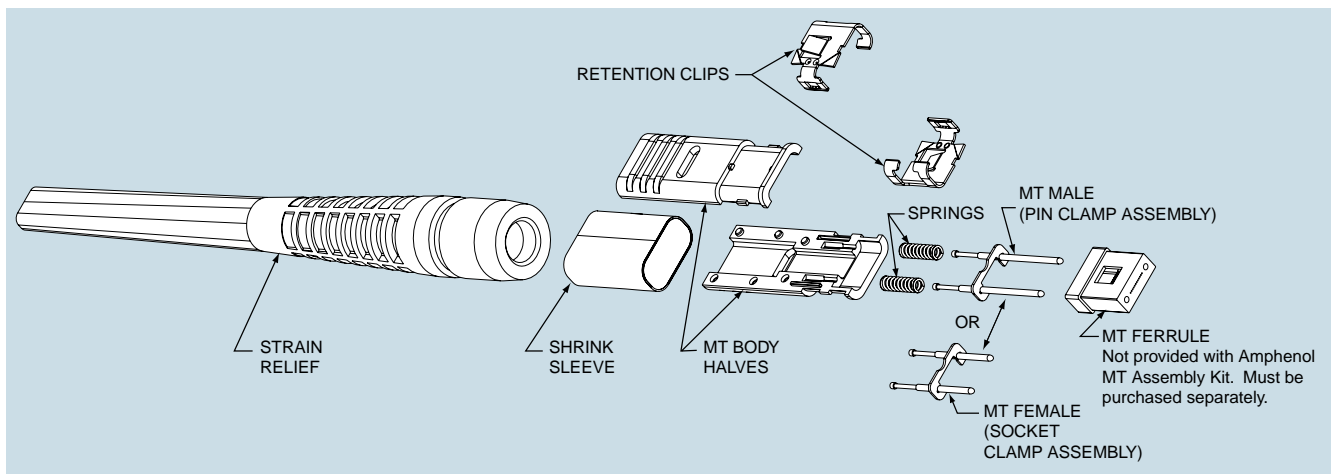
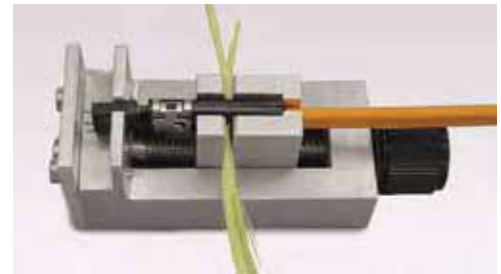

For information on MT fiber optics in Amphenol rectangular interconnects please contact an Amphenol Sales Person or consult Amphenol, Sidney, NY by calling 1-800-678-0141.

38999  
SJT I II III

26482  
Matrix 2

83723 III  
Matrix Pyle

5015  
Crimp Rear Release Matrix

26500 Pyle

Printed  
Circuit Board

EMI Filter  
Transient

Fiber Optics

High Speed  
Contacts

Options  
Others

# Multi-Channel Fiber Optic Circular Connector with MT Ferrules-MT38999, How to Order

Amphenol offers a multi-channel circular connector with high density MT fiber optics. This connector uses MT ferrules described on page 358.

## The features of the MT cylindrical connector include:

- High fiber density in a relatively small circular connector package with all the advantages of the MIL-DTL-38999 series III connector
- Three levels of alignment provide for precision fiber to fiber interface:
  - Shell to shell with keying to allow for alternate positions
  - Insert plug to insert receptacle
  - MT contact guide pins
- Ferrules are available in either 12-fiber or 24-fiber versions, in multi-mode PC, single mode PC, and single mode APC configurations
- 2 arrangements are available as shown at right, shell size 11 with one ferrule, and shell size 21 with four ferrules



MT38999 Connectors

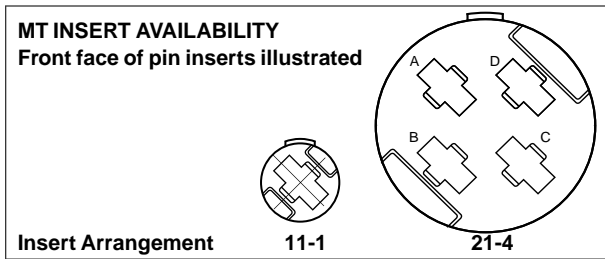

Amphenol® MT38999 connectors for use with MT ferrule termini can be ordered by coded part number. Ordering procedure is illustrated by part number CF-699011-01P as shown below:

## Easy Steps to build a part number... CF, Tri-Start Series III with Fiber Optics

| 1.             | 2.              | 3.             | 4.           | 5.          | 6.                             | 7.                                |
|----------------|-----------------|----------------|--------------|-------------|--------------------------------|-----------------------------------|
| Connector Type | Connector Class | Terminus Style | Shell Finish | Shell Style | Shell Size- Insert Arrangement | Insert Type & Key/Keyway Position |
| CF-            | 6               | 9              | 9            | 0           | 11-01                          | P                                 |

### Step 1. Select a Connector Type

|     |  |
|-----|--|
| CF- | Designates Multi-Channel Fiber Optic Connector |
|-----|--|

### Step 2. Select a Connector Class

|   |  |
|---|--|
|   | Designates                             |
| 5 | Aluminum shell, tight tolerance        |
| 6 | Composite shell, tight tolerance       |
| 8 | Stainless Steel shell, tight tolerance |

### Step 3. Terminus Style

|   |                                 |
|---|---------------------------------|
|   | Designates                      |
| 9 | MT terminus - Flat ribbon cable |
| R | MT terminus - Round cable       |

### Step 4. Select a Shell Finish

|   |  |
|---|--|
|   | Designates   |
| 4 | electroless nickel plated aluminum, 48 hour salt spray resistance, 200°C                     |
| 5 | unplated composite   |
| 6 | Corrosion resistant stainless steel, 500 hour salt spray resistance, 200°C                   |
| 9 | Corrosion resistant olive drab cadmium plate aluminum, 500 hour salt spray resistance, 175°C |
| D | Durmalon™ (Nickel-PTFE)  |

### Step 5. Select a Shell Style

|   |                       |
|---|-----------------------|
|   | Designates            |
| 0 | Wall mount receptacle |
| 1 | Line receptacle       |
| 2 | Box mount receptacle  |
| 6 | Straight plug         |
| 7 | Jam nut receptacle    |

### Step 6. Select a Shell Size- Insert Arrangement

|                           |                               |
|---------------------------|-------------------------------|
| Shell Size - Insert Arrg. | Designates                    |
| 11-01                     | Shell size 11 - Single cavity |
| 21-04                     | Shell size 21 - Four Cavity   |

### Step 7. Insert Type & Key/Keyway Position

Insert Type and Keyway Position  
 P designates pin insert  
 S designates socket insert  
 For keyway positioning, choose the alternate rotation suffix from the chart below.

#### ALTERNATE POSITION SUFFIX

| Alternate Position | Suffix Letter |         |
|--------------------|---------------|---------|
|                    | Pins          | Sockets |
| Normal             | P             | S       |
| A                  | G             | H       |
| B                  | I             | J       |
| C                  | K             | L       |
| D                  | M             | N       |
| E                  | R             | T       |

Information on MT termini is provided on page 358.

Durmalon is a trademark of Amphenol Aerospace. For more information on Durmalon, go to [www.amphenol-aerospace.com/durmalon.asp](http://www.amphenol-aerospace.com/durmalon.asp)

38999 III II I SJT

26482 Matrix 2

83723 III Matrix Pyle

5015 Crimp Rear Release Matrix

26500 Pyle

Printed Circuit Board

EMI Filter Transient

Fiber Optics

High Speed Contacts

Options Others

38999  
SJT I II III

26482  
Matrix 2

83723 III  
Matrix Pyle

5015  
Crimp Rear Release Matrix

26500 Pyle

Printed  
Circuit Board

EMI Filter  
Transient

Fiber Optics

High Speed  
Contacts

Options  
Others

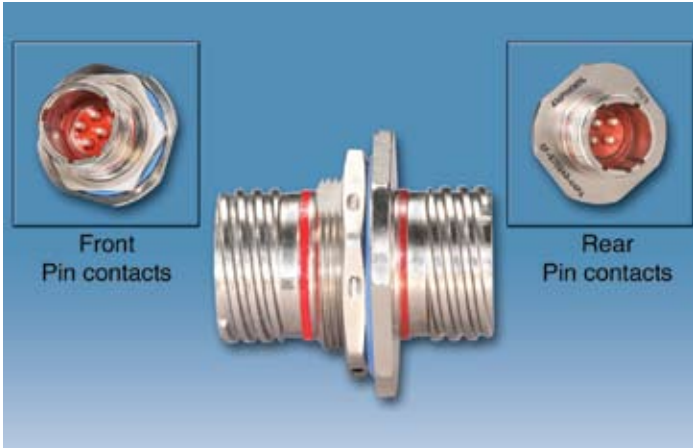

**Fiber Optic Bulkhead Feed-Through Connector (Special size 16 Pin-Pin Termini Configuration)**

Amphenol extends its line of harsh environment fiber optic components with a multi-channel fiber optic feed-through. This feed-through is designed to perform in demanding aerospace environments and any other applications where a high degree of environmental sealing is required between bulkheads.

**Fiber Optic Bulkhead Feed-Through Features include:**

- Fully compatible with D38999 and Amphenol® CF-series fiber optic connectors
- Jam nut style for easy installation
- Available with M29504 fiber optic termini
- Meets or exceeds hermeticity of 10<sup>-7</sup> cc/min. He leak testing
- Available finishes include electroless nickel and olive drab cadmium
- Typical fiber sizes include 50/125 and 62.5/125 multi-mode fiber.

**Fiber Optic Bulkhead Feed-Through Connector**

Jam Nut Receptacle CF-97024x/CF-97019X

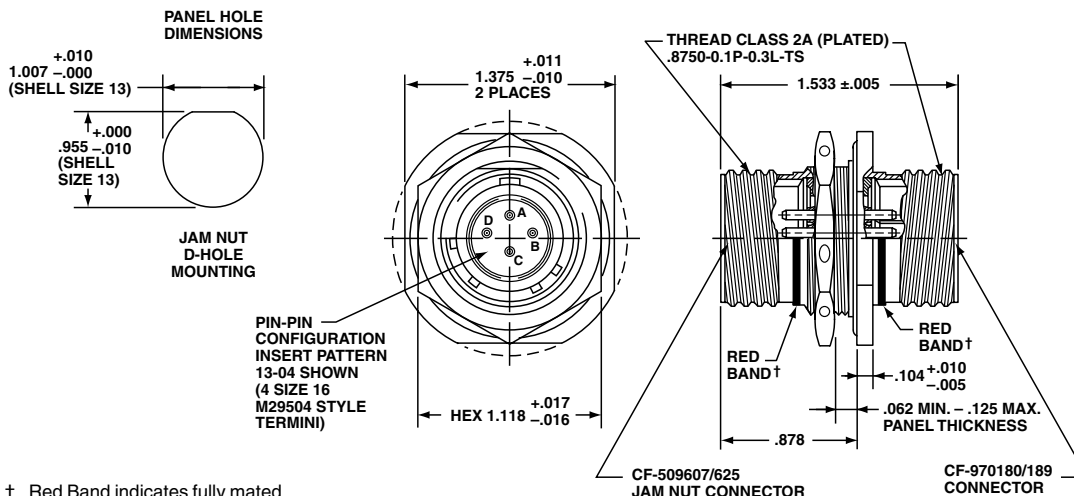

† Red Band indicates fully mated  
 All dimensions for reference only.

**HOW TO ORDER**

**Fiber Optic Bulkhead Feed-through Connectors**

|                                   |                      |                |
|-----------------------------------|----------------------|----------------|
| Bulkhead Feed-through Shell Style | Amphenol Part Number |                |
|                                   | Finish               |                |
|                                   | Electroless Nickel   | OD Cadmium     |
| Jam Nut Receptacle                | CF-97024X-YYPA       | CF-97019X-YYPA |

|                     |                     |    |    |    |    |    |    |    |
|---------------------|---------------------|----|----|----|----|----|----|----|
| Shell Size          | Insert Arrangements |    |    |    |    |    |    |    |
|                     | 11                  | 13 | 15 | 17 | 19 | 21 | 23 | 25 |
| 'X' in part number  | 2                   | 3  | 4  | 5  | 6  | 7  | 8  | 9  |
| 'YY' in part number | 02                  | 04 | 05 | 08 | 11 | 16 | 21 | 29 |

PA suffix - indicates pin with Normal rotation on jam nut end and 'A' rotation (mirror image) on opposite end.



### HOW TO ORDER

#### Protection Caps

| Shell Size | Plastic Protection Caps |                 | MS Metal Protection Caps |                |                    |
|------------|-------------------------|-----------------|--------------------------|----------------|--------------------|
|            | For Plugs               | For Receptacles | MS Shell Size Code       | For MS Plugs   | For MS Receptacles |
| 9          | 10-70506-14             | 10-70500-10     | A                        | D38999/32W9X*  | D38999/33W9X*      |
| 11         | 10-70506-16             | 10-70500-12     | B                        | D38999/32W11X* | D38999/33W11X*     |
| 13         | 10-70500-18             | 10-70500-14     | C                        | D38999/32W13X* | D38999/33W13X*     |
| 15         | 10-70500-20             | 10-70500-16     | D                        | D38999/32W15X* | D38999/33W15X*     |
| 17         | 10-70500-22             | 10-70500-19     | E                        | D38999/32W17X* | D38999/33W17X*     |
| 19         | 10-70500-24             | 10-70500-20     | F                        | D3899/32W19X*  | D38999/33W19X*     |
| 21         | 10-70524-1              | 10-70500-22     | G                        | D3999/32W21X*  | D38999/33W21X*     |
| 23         | 10-70506-28             | 10-70500-24     | H                        | D38999/32W23X* | D38999/33W23X*     |
| 25         | 10-70500-28             | 10-70524-1      | J                        | D3899932W25X*  | D38999/33W25X*     |

#### Sealing Plugs

| Sealing Plugs for Unused Contact Cavities |                |              |
|---|----------------|--------------|
| Contact Size                              | Commercial No. | Military No. |
| 8 (Coax)                                  | 10-482099-8    | N/A          |
| 8 (Twinax)                                | T3-4008-59P    | N/A          |
| 8 (Power)                                 | 10-405996-81   | MS27488-8-1  |
| 10 (Power)                                | 10-576225      | N/A          |
| 12  | 10-405996-121  | MS27488-12-1 |
| 16  | 10-405996-161  | MS27488-16-1 |
| 20  | 10-405996-201  | MS27488-20-1 |
| 22D                                       | 10-405996-41   | MS27488-4-1  |

\* To complete order number, replace X with applicable letter as follows:  
 R - designates eyelet type  
 N - designates washer type

MS metal protection caps are supplied with service class W which designates corrosion resistant olive drab cadmium plate aluminum.



Protection Caps



Sealing Plugs

Amphenol offers the widest range of accessories for circular connectors conforming to most Military (MIL) specifications.

Please visit [www.backshellworld.com](http://www.backshellworld.com) for more information about backshells and a configurator to build a part number... see Backshell Designer.

#### Backshells

Some Backshells can be used without any additional protection while other types are generally used with heat shrink boots or similar protection/strain relief mechanism depending on specific requirements.

Backshells for Military & Aerospace applications are governed by SAE, AS85049 standard and Amphenol Backshells are designed to meet the requirement of this standard. Amphenol offers additional styles and designs and can support you from concept to product realization to satisfy your unique specifications. Please contact your Sales Associate or Technical Assistance for more information.

- Non-Environmental Backshell
- Environmental Backshell
- Non-Environmental EMI/RFI Backshell
- Environmental EMI/RFI Backshell
- Shrink Boot Adaptor
- Crimp Ring Adaptor
- Band Lock Adaptor
- SQ Adaptor
- Quick Clamp
- Strain Relief Clamp
- Grommet Nut
- Lamp Thread Adaptor

III  
II  
I  
SJT  
38999

Matrix 2  
26482

Matrix Pyle  
83723 III

Release Matrix  
5015  
Crimp Rear

26500 Pyle

Printed  
Circuit Board

EMI Filter  
Transient

Fiber Optics

High Speed  
Contacts

Options  
Others

The following data includes information pertaining to the application tools which have been established for polishing, inserting and removing multi-mode fiber optic termini within multi-channel connectors. Insertion and removal tools are common to MIL-DTL-38999 size 16 and size 20 tools. Installation instructions L-1262 for multi-mode size 16 and L-2103 for multi-mode size 20 provide proper installation and polishing procedures for these termini. These are available on-line at [www.amphenol-aerospace.com](http://www.amphenol-aerospace.com), under service instructions. Termination kits, as shown at right, are available for each Amphenol –connector family. The kit includes the carrying case, heat gun, crimping and stripping tools and microscope with adapters.



**Plastic Insertion/Removal Tool for Size 16 Multi-mode Termini**



**Termination Kit**

### HOW TO ORDER

#### Application Tools for Multi-Channel, Multi-mode Fiber Optic Termini

| Contact Size/Type | Termini Part Number                           | Hand Polishing Tools*                               | Machine Polishing Tools                                |  | Termination Kit (Includes necessary field termination equipment) |
|-------------------|---|---|--|--|--|
|                   |   |   | Amphenol/Buehler Fibrmet*** Polishing Tool Part Number | Amphenol/Buehler Fibrscope*** Adaptor Body Part Number |  |
| 16 Multi-mode     | CF-198035-( )** Socket<br>CF-198036-( )** Pin | 11-12123 or<br>11-12195 (grooved for wet polishing) | 11-12103   | 11-12104   | CF-8500-1†   |
| 20 Multi-mode     | CF-198080-( )** Socket<br>CF-198081-( )** Pin | 11-12153  | N/A  | N/A  | CF-8500-3††  |

#### Insertion Tools

| Contact Size/Type | Plastic Tools (Double ended insertion/removal tool) |            | Metal Tools    |                               |                                      |       |
|-------------------|---|------------|----------------|-------------------------------|--------------------------------------|-------|
|                   | MS Part Number                                      | Color      | Angle Type     |                               | Straight Type Commercial Part Number | Color |
|                   |   |            | MS Part Number | Commercial Part Number        |                                      |       |
| 16 Multi-mode     | M81969/14-03  | Blue/White | M81969/8-07    | 11-8674-16<br>11-012197-16††† | 11-8794-16<br>11-012198-16†††        | Blue  |
| 20 Multi-mode     | M81969/14-10  | Red/Orange | M81969/8-05    | 11-8674-20                    | 11-8794-16                           | Red   |

#### Removal Tools

| Contact Size/Type | Plastic Tools (Double ended insertion/removal tool) |            | Metal Tools                                 |                |                        |                                      |       |
|-------------------|---|------------|---|----------------|------------------------|--------------------------------------|-------|
|                   | MS Part Number                                      | Color      | For Unwired Contacts Commercial Part Number | Angle Type     |                        | Straight Type Commercial Part Number | Color |
|                   |   |            |   | MS Part Number | Commercial Part Number |                                      |       |
| 16 Multi-mode     | M81969/14-03  | Blue/White | 11-10050-10                                 | M81969/8-08    | 11-8675-16             | 11-8795-16                           | White |
| 20 Multi-mode     | M81969/14-10  | Red/Orange | 11-10050-9                                  | M81969/8-06    | 11-8675-20             | 11-8795-20                           | White |

♦ FOR APPLICATION TOOLS FOR SINGLE MODE TERMINI, CONSULT AMPHENOL AEROSPACE.

The M81969/8, 11-8675 and 11-8794 metal contact insertion and removal tools will accommodate wires having the maximum outside diameter of .105 for size 16 and .084 for size 20. When wire diameters exceed this, the plastic tools must be used.

\* Single Termini Capability

\*\* To complete order number add fiber size; see ordering information on page 3 for size 16 multi-mode, and page 4 for size 20 multi-mode.

\*\*\* Fibrmet and Fibrscope are registered trademarks of Buehler Ltd.

† This includes hand polishing tool 11-12123.

†† This includes hand polishing tool 11-12153.

††† Recommended tool for socket termination insertion.

38999  
SJT I II III

26482  
Matrix 2

83723 III  
Matrix Pyle

5015  
Crimp Rear Release Matrix

26500 Pyle

Printed  
Circuit Board

EMI Filter  
Transient

Fiber Optics

High Speed  
Contacts

Options  
Others



### Fiber Optic Custom Cable Assembly Design and Fabrication

Amphenol's cable assembly expertise dates back to the first industry standard fiber optic connector, over 25 years ago. Our depth of understanding of connector and termini design, and the complete control of connector materials, make Amphenol Fiber Optic cable assemblies one of the best in the industry. Amphenol offers a comprehensive line of single mode and multi-mode cable assemblies in a variety of cable configurations. From simplex jumpers to multi-fiber custom assemblies, Amphenol can design and supply all of your cable needs.

High quality polishing processes have been developed to meet and exceed industry standard specifications for insertion loss, return loss and end-face geometry. All assemblies are designed to intermateability standards for optical and physical performance criteria.

Amphenol can assemble, polish and test many harsh environment and commercial grade connectors including:

- MIL-PRF-29504/4, /5, /14, /15
- HD20
- MTC/MP0
- ARINC 801
- ST
- LC
- FC
- SC

Connector and cable materials are extensively inspected prior to assembly. Every completed cable assembly receives 100% inspection for both insertion loss and visual defects. Interferometers are used for accurate end-face geometry testing.

You specify the optical and mechanical requirements of the cable assembly and Amphenol's fiber optic application's engineers will develop an "end-to-end" interconnect solution. Design creativity, experience and an understanding of harsh environments will ensure a functional and manufacturable design. See the next page for a guide to selecting and specifying a fiber optic cable assembly.



**D38999 Fiber Optic Connectors and Cables**



**ARINC 801 Connectors and Cables**



**Explosion Proof Amphe-EX™ Connectors and Cables**

38999  
III  
II  
I  
SJT

26482  
Matrix 2

83723 III  
Matrix  
Pyle

5015  
Crimp Rear  
Release Matrix

26500 Pyle

Printed  
Circuit Board

EMI Filter  
Transient

Fiber Optics

High Speed  
Contacts

Options  
Others

The following criteria should be considered when specifying a fiber optic cable assembly. You may copy this page and fax it Amphenol Aerospace\*. Our design engineers are ready to help meet your custom cable application requirements.



### Typical Breakout Cable Assembly shown:

- Connector ends: CF38999 Fiber Optic Jam Nut Receptacle; and Commercial grade ST
- Termini in the CF38999 connector are size 16 single mode
- Optical wavelength: 1300
- Cable: Avionics grade; 1 ft. length



This check list is provided to help ensure a thorough design of a custom fiber optic cable assembly.

### ENVIRONMENTAL CRITERIA

- High Temperature \_\_\_\_\_
- Low Temperature \_\_\_\_\_
- Salt Spray \_\_\_\_\_
- Mechanical Shock \_\_\_\_\_
- Mechanical Vibration \_\_\_\_\_
- Durability \_\_\_\_\_

### COMPONENTS

#### Termini

- MIL-PRF-29504
  - Pin \_\_\_\_\_
  - Socket \_\_\_\_\_
- ARINC 801
- MTC
- HD20
- Other \_\_\_\_\_

#### Connectors - Cylindrical

- CF38999
- ARINC 801
- MT38999

#### Connectors - Rectangular

- Low mating force, PCB \_\_\_\_\_
- LRM
- Rack and Panel
- VME64X
- VITA-46

#### Accessories

- Backshells/Strain Reliefs \_\_\_\_\_
- Sealing plugs \_\_\_\_\_
- Protection caps \_\_\_\_\_

### OPERATIONAL CRITERIA

- Assembly Length and Tolerance \_\_\_\_\_

#### Optical Wavelength

- 850
- 1300
- 1550
- Other \_\_\_\_\_

#### Fiber Core Size

- 5/125 single mode
- 9/125 single mode
- 50/125 multi-mode
- 62.5/125 multi-mode
- 100/140 multi-mode
- 200/230 multi-mode
- Other \_\_\_\_\_

#### Performance

- Insertion Loss
- Return Loss

#### Cable Type

- Field Tactical
- LSZH
- Breakout
- Distribution
- Avionics

#### Special Options

- EMI Shielding
- Hermetic Backfill

\* Fax to 607-563-5157, attention Fiber Optic Design Engineering, Amphenol Aerospace. Or call 607-563-5011 for further assistance.

38999  
SJT I II III

26482  
Matrix 2

83723 III  
Matrix Pyle

5015  
Crimp Rear Release Matrix

26500 Pyle

Printed  
Circuit Board

EMI Filter  
Transient

Fiber Optics

High Speed  
Contacts

Options  
Others

# Amphenol High Frequency Contacts



CONCENTRIC  
TWINAX



COAXIAL



TWINAX PC TAIL



TRIAx



DIFFERENTIAL  
TWINAX



QUADRAX



## TABLE OF CONTENTS

- Table of Contents . . . . . 365
- Overview of Amphenol's High Frequency Contacts . . . . . 366-370
- Cable Systems . . . . . 371
- Cable Usage Guide . . . . . 372-375

### MIL-DTL-38999 Circular Connector Overview . . . . . 376

#### Contacts for MIL-DTL-38999 Connectors:

- Quadrax Contacts . . . . . 377-379
- Differential Twinax Contacts . . . . . 380, 381
- Compliant Quadrax and PC Tail Quadrax Contacts . . . . . 382
- Quadrax Transition & Differential Twinax Transitional Adapters . . . . . 383-386
- Insert Arrangements for MIL-DTL-38999 Series III Incorporating Quadrax and Differential Twinax Contacts . . . . . 387, 388
- How to Order 38999 Series III with Quadrax 100 ohm Contacts . . . . . 389
- Coaxial Contacts . . . . . 390-393
- Matched Impedance Coaxial Contacts . . . . . 394
- Typical Contact Installation Instructions for Coax Contacts . . . . . 395
- High Frequency Contacts (DC to 40 GHz) . . . . . 396
- Twinax Contacts . . . . . 397-399
- Triax Contacts . . . . . 400
- Coax, Twinax & Triax PC Tail Contacts . . . . . 401-403
- Insert Patterns for MIL-DTL-38999 Series III Incorporating Coax, Twinax and Triax Contacts . . . . . 404-406

### Standard MIL-DTL-5015 & Heavy Duty MIL-DTL-22992 Circular Connector Overview . . . . . 407

#### Contacts for Standard MIL-DTL-5015 & Heavy Duty

#### MIL-DTL-22992 Connectors:

- Coaxial Contacts . . . . . 408, 409
- Insert Patterns for Standard MIL-DTL-5015 and Heavy Duty MIL-DTL-22992 Incorporating Coax Contacts . . . . . 410
- Rectangular Rack & Panel Connectors that incorporate High Speed . . . . . 411, 412
- Additional Contact Styles from Amphenol . . . . . 413
- Guide for Selecting High Frequency Contacts and Cables . . . . . 414



## High Frequency Contacts Typical Markets:

- Military & Commercial Aviation
- Military Vehicles
- Missiles & Ordnance
- C4ISR





38999  
SJT I II III

26482  
Matrix 2

83723 III  
Matrix Pyle

5015  
Crimp Rear  
Release Matrix

26500 Pyle

Printed  
Circuit Board

EMI Filter  
Transient

Fiber Optics

High Speed  
Contacts

Options  
Others

When you need superior electrical performance plus shielding to eliminate interference from outside electrical sources in a connector, Amphenol has the most reliable contact solutions.

Amphenol offers a very wide range of contacts that provide high speed transmission and operate in high frequency conditions. You can be assured of interconnection compatibility when you come to Amphenol for your contact needs as well as your connector needs. Amphenol's expertise in interconnection solutions assures that your contacts will mate properly and will perform to the application specifications of your particular requirements.

*MIL-DTL-38999 CONNECTORS - The high performance series most ideal for integrating high speed and high frequency contacts. MIL-DTL-38999, Series I, II and III are by far the choice of connector for today's avionics needs - these subminiature family connectors are ideally suited for the incorporation of shielded contacts.*

This catalog section is primarily devoted to the high speed and high frequency contact options for use in MIL-DTL-38999 Connectors, which include:



| Coaxial   | Concentric Twinax  | Triax   | Quadrax  | Differential Twinax   | High Frequency   | Transition Adapters  |
|---|--|---|--|---|--|--|
| Pin and socket contacts designed for RF/microwave and shielded wire applications. Sizes 4, 8, 12 & 16 | Pin and socket contacts designed for protection from magnetic and electrostatic interference including nuclear electromagnetic pulse. Sizes 8 & 12 | Pin and socket contacts designed for shielded wire applications with 3 conductors. Sizes 8, 10 & 12 | Size 8 pin and socket contacts. An outer contact with 4 strategically spaced inner contacts forming two 100 or 150 Ohm matched impedance differential pairs. | Size 8 pin and socket contacts. An outer contact with 2 inner contacts spaced to form one 100 or 150 Ohm matched impedance differential pair. | Size 8 Coaxial contacts that provide high frequencies (DC to 40 GHz). Unique "Float Mount" technology maintains tight mechanical tolerances. | Matched impedance quadrax and twinax transition adapters provide a method of launching from the high speed connectors to PCB boards. |

Other series of connectors from Amphenol Aerospace, in addition to 38999 connectors, can incorporate shielded contacts. These include the following (and are also covered in this catalog section):

- Amphenol® Heavy Duty Circular Connectors, MIL-DTL-22992 - with coax contacts.
- Amphenol® Printed Circuit Board Connectors - Rectangular connectors with standard low mating force brush contacts can have hybrid arrangements with coax contacts.
- LRM Interconnects - Rectangular module and backplane connectors with standard low mating force brush contacts can have hybrid arrangements with coax contacts.
- Amphenol® ARINC 600 and R27 Rack & Panel Connectors are available with quadrax, coax, twinax and differential twinax contacts.

The Cable Usage Guide is a key reference to help guide you in selecting the contacts best suited to your needs. Since most shielded wire applications start with a fixed requirement for cable types, the guide refers you to the Amphenol connector family utilizing contacts which are compatible with the cable characteristics.

For more information on other Amphenol connectors with shielded contacts:

- Amphenol® Circular Connectors, MIL-DTL-26482, Series 1 are available with coaxial contacts, size 8 and 12 for crimp and solder type. See catalog 12-070 on-line at [www.amphenol-industrial.com](http://www.amphenol-industrial.com), or consult Amphenol Industrial Operations.
- Amphenol® MS/Standard, MIL-DTL-5015 Circular Connectors are available with size 4, 8 and 12 coax contacts. Consult Amphenol Industrial Operations for more information or on-line at [www.amphenol-industrial.com](http://www.amphenol-industrial.com).

For more information on connectors with fiber optics see the Fiber Optic section of this catalog or consult Amphenol Aerospace, Sidney, NY.

See High Frequency Contact Designer's Guide at end of this catalog.





Amphenol provides the latest technology in high speed contacts - differential twinax and quadrax contacts, size 8, for use in MIL-DTL-38999 Special\* Circular Connectors.

## DIFFERENTIAL TWINAX CONTACTS

High speed Differential Twinax contacts consist of an outer contact with two inner contacts spaced to form one 100 or 150 Ohm controlled impedance differential pair. See pages 380 and 381 for performance data and ordering of Differential Twinax contacts, and consult Amphenol Aerospace for more information.



**Differential Twinax Contact**



**Quadrax Contact**

## QUADRAX CONTACTS

- High speed Quadrax contacts consist of an outer contact with four inner contacts spaced to form two 100 or 150 Ohm controlled impedance differential pair.

- Both contacts, when used in Amphenol MIL-DTL-38999 Series III and ARINC type connectors, provide an excellent alternative for harsh environment applications such as:
  - Ethernet 100 Base-T-100 Ohm
  - Gigabit Ethernet 1000 Base-T-100 Ohm
  - Fibre Channel-150 Ohm
  - IEEE1394B FireWire-110 Ohm

Differential Twinax and Quadrax contact options include:

- Crimp or printed circuit board termination
- Established designs to accommodate a variety of cable types and gages
- Ground plane connectors can incorporate quadrax contacts. These connections have conductive inserts that ground the outer conductor of the contact body to the shell of the connector. They accommodate size 8 and 12 shielded contacts of which the size 8 can be quadrax type.

See pages 377-379 for performance data of Quadrax contacts. Consult Amphenol Aerospace for further information needed.

\* Requires modified connector to accommodate keyed contacts.

Differential Twinax and Quadrax contacts provide high data transfer rates, low power consumption, and excellent EMI capability. They offer controlled impedance of 100 or 150 Ohm and are ideal for use in harsh environments.



*D38999 Series III Ground Plane Connectors with Quadrax PCB Socket contacts*



*D38999 Series III with Quadrax and Power Contacts*



*D38999 Series III Connectors (standoff shell at right and standard shell below) with Quadrax PC Tail Contacts*



III  
II  
I  
SJT  
38999

26482  
Matrix 2

83723 III  
Matrix  
Pyle

5015  
Crimp Rear  
Release Matrix

26500 Pyle

Printed  
Circuit Board

EMI Filter  
Transient

Fiber Optics

High Speed  
Contacts

Options  
Others

38999  
SJT I II III

**QUADRAX CONTACTS FOR ARINC CONNECTORS**

Amphenol ARINC 600 Rack and Panel connectors can incorporate high speed quadrax contacts as well as coax, twinax and differential twinax contacts. R27 Rack and Panel connectors use the same contacts as ARINC 600 connectors. For more information about rack and panel connectors contact Amphenol Aerospace, Sidney, NY.



**Quadrax Contact for ARINC Connectors**

26482  
Matrix 2

**BOARD LEVEL CONNECTORS WITH COMPLIANT QUADRAX CONTACTS**

Amphenol also provides compliant quadrax socket contacts and Quadrax pin contacts with PC tails for attaching to printed circuit boards. See page 382 for more information.



**Compliant Quadrax Socket and PCB Tail Quadrax Pin**

83723 III  
Matrix Pyle

**FEED-THROUGH CONNECTOR WITH QUADRAX CONTACTS**

Amphenol's feed-through connector is double-ended for through bulkhead applications. Consult Amphenol for more information.



5015  
Crimp Rear Release Matrix

26500 Pyle

Printed Circuit Board

**Quadrax Terminators**

Amphenol offers a terminator assembly which is a low reactance, resistive impedance match to the characteristic impedance of a transmission line. It is used to terminate the far ends of a transmission line or an open tap so that the energy from signals traveling down the transmission line is absorbed within the resistor and not reflected back down the transmission line causing signal interference (noise). Consult Amphenol for more information.



**Quadrax Terminator**

EMI Filter Transient

Fiber Optics

High Speed Contacts

**Transition Adapters**

In conjunction with its Differential Twinax and Quadrax contacts, Amphenol has developed a full line of Transition Adapters in order to facilitate launching of controlled impedance signals to printed circuit boards. These use differential twinax or quadrax 90° or straight receptacles and they can be either threaded or cable to board direct. The threaded transition adapters provide an ideal method of disconnecting the differential twinax or quadrax connector from the board.

See pages 383-385 for further description, performance data and ordering of transition adapters.

Options Others

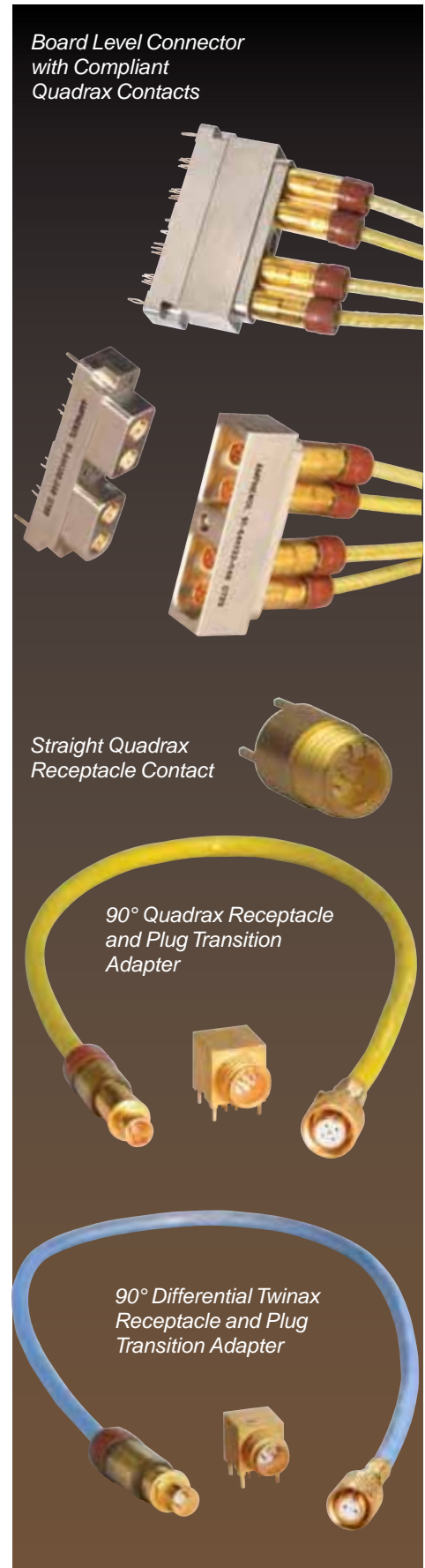

*Board Level Connector with Compliant Quadrax Contacts*

*Straight Quadrax Receptacle Contact*

*90° Quadrax Receptacle and Plug Transition Adapter*

*90° Differential Twinax Receptacle and Plug Transition Adapter*



Optional choices, other than standard crimp or solder 500 cycle and 1500 cycle contacts, are often required for high frequency interconnections. Amphenol offers shielded contacts for RF applications as well as balanced high sensitivity circuits.

## SHIELDED COAXIAL CONTACTS

High speed Coax contacts within a connector provide the shielding protection, and many cases the RF/microwave performance, needed in the circuitry of many applications.



**Shielded Coax Contacts**

All popular series of Amphenol circular connectors and many rectangular connectors are available with coax contacts. Diameters are standardized in sizes 4, 8, 12 and 16 so that coaxial contacts may be interchanged with power contacts in connector arrangements which include those sizes. Popular RG cable types and a variety of other commercial coaxial cables can be accommodated. See page 390 for coax contact performance data. Matched impedance size 12 coax contacts are also available (see page 394). The use of coax contacts within a connector, compared to the use of individual coaxial/shielded connectors, offers advantages of savings in space and weight and no cross-mating difficulties. Coax and standard contacts may be mixed within the connector to meet special signal needs. The connector itself offers further protection and environmental integrity through the grommets and seals used, and coaxial junction is protected by the connector outer shell.

## CONCENTRIC TWINAX SHIELDED CONTACTS

High performance shielding capabilities are available with Concentric Twinax contacts. These are designed for protection from magnetic and electrostatic interference including nuclear electro-magnetic pulse. The contact is crimp terminable to twisted shielded cable and is fully scoop-proof (recessed pins) in MIL-DTL-38999 connectors. The concentric twinax contact is engineered to maintain shield integrity through a multi-pin circular connector and does not require contact polarization within the insert. Size 8 concentric twinax contacts were developed for use in MIL-STD-1553B Airborne multiplex data bus applications. Ideal for this application need is the high performance Tri-Start connector with its fully scoop-proof feature of recessed pins.



**Concentric Twinax Contacts Size 8**



**MIL-DTL-38999 Lanyard "Breakaway" Connector with Concentric Twinax Contacts, Qualified for MIL-STD-1760**

The concentric twinax contact is crimp terminable to twisted shielded cable. Size 12 concentric twinax contacts were developed for SAAB. They can be used in any size 12 cavity of D38999 I, II or III or SJT connector.

Size 8 & 12 coax, triax or twinax contacts or size 16 coax contacts are available in Ground Plane Connectors (See photo preceding page). These are MIL-DTL-38999 Series III connectors for data bus, LAN and coax/triax/twinax transmission lines with conductive inserts that ground the outer contact conductor to the shell. They are sold "less contacts"

*Amphenol® Shielded Contacts provide design versatility for electrical circuitry. Shielded contacts are used to eliminate interference from outside electrical sources, when standard crimp or solder contacts are not enough.*



*MIL-DTL-38999 Connector with High Speed Coax Contacts*



*Size 8 Coax Pin Contact*

*Concentric Twinax Size 12 Contacts*



*MIL-DTL-38999 Connector with Concentric Twinax Contacts*



III  
II  
I  
SJT  
38999

Matrix 2  
26482

Matrix  
Pyle  
83723 III

Release Matrix  
Crimp Rear  
5015

26500 Pyle

Printed  
Circuit Board

EMI Filter  
Transient

Fiber Optics

High Speed  
Contacts

Options  
Others

- 38999  
SJT I II III
- 26482  
Matrix 2
- 83723 III  
Matrix Pyle
- 5015  
Crimp Rear  
Release Matrix
- 26500 Pyle
- Printed  
Circuit Board
- EMI Filter  
Transient
- Fiber Optics
- High Speed  
Contacts
- Options  
Others

**HIGH FREQUENCY  
COAX CONTACTS WITH  
“FLOAT MOUNT”  
TECHNOLOGY**

Amphenol Aerospace now offers DC to 40 GHz size 8 coaxial contacts for the D38999 housing and standard inserts. These contacts can be terminated to a multiple of cable types depending on the application.

By using standard interfaces that are based on MIL-STD-348 and can be installed in any D38999 size 8 insert, Amphenol has transformed the circular connector industry. This technology expands the use of D38999 connectors to include the microwave transmission lines within the multi-port configuration without change to a custom connector.

The high frequencies are maintained by Amphenol’s unique “Float Mount” technology. This technology allows for consistent microwave performance while maintaining tight mechanical tolerances. This consistency provides superior electrical performance and, unlike other blindmate connectors, will maintain an accurate phase length when mated. See page 396 for specifications, performances and ordering of this contact.



**High Frequency Size 8 Coax  
Contacts with “Float Mount”  
Technology**

**Twinax Contacts for Printed  
Circuit Board Applications**

**PC TAIL TWINAX  
CONTACTS**

Amphenol provides Printed Circuit Tail Twinax contacts for MIL-DTL-38999 Series I and III circular connectors and also for ARINC 404 and ARINC 600 rectangular connectors. High reliability is assured with factory pre-assembled contacts and standardized termination to the board.

See pages 401-403 for performance data and ordering of PC tail twinax contacts, and consult Amphenol Aerospace for further information needed. Also see the Printed Circuit Board, and the Series I, II, III section for MIL-DTL-38999 connectors.



**Variety of PC Tail Twinax Contacts**

**TRIAX CONTACTS WITH  
THREE CONDUCTORS FOR  
USE WITH TRIAX CABLE**

Amphenol supplies sizes 8, 10 and 12 triax contacts for use in MIL-DTL-38999 Series I, II and III connectors. Triax contacts provide additional shielding when terminated to triax cable having solid or stranded center conductors. See cable compatibility in the Cable Usage Guide and performance data and ordering of triax contacts on pages 400-403. Each of the three conductors of the triax contact is separated by dielectric insulation to isolate ground planes and to improve shielding effectiveness. All conductors are crimp terminated for high reliability and ease of assembly. Triax contacts may be specified for direct connection to printed circuit boards. For maximum system flexibility, triax contacts may be mixed with coax, twinax and power contacts in a single connector.



**Triax Contacts**

*HF38999 - D38999 Connectors with  
High Frequency Coax Contacts*



*D38999 Connectors  
with PC Tail  
Twinax  
Contacts*



*Printed Circuit Twinax Contacts provide a cost effective packaging solution for limited space applications where connectors are attached to printed circuit boards.*

*Rail Launch MIL-STD-1760  
Connector with  
Triax Contacts*



## CABLE ASSEMBLY CAPABILITIES

Amphenol provides a large array of cable assemblies with high speed quadrax and differential twinax contacts, as well as coax and concentric twinax contacts. This page shows a few examples. The Cable Usage Guide pages that follow list the design possibilities for these high speed contacts.

Amphenol strives to offer customers the widest range of cable assemblies, keeping abreast of the latest cable types in the marketplace. Please consult with the contact product managers at Amphenol Aerospace for assistance in designing the cable assembly that suits your particular needs. From a simple one-cable interconnection, to a multiple cable system, Amphenol can design and supply your cable needs for high frequency contacts and connectors. See the High Frequency Contact Designer's Guide at the end of this catalog



Variety of Quadrax Cable Assemblies

## TESTING OF CABLES

Rigid testing is performed 100% on cable assemblies at Amphenol before they are shipped to make sure they meet customer requirements. These requirements include tests such as DWV, resistance and continuity. Amphenol has the background experience and understanding of harsh environmental testing to assure reliable "end-to-end" interconnect solutions.



Eight Wire Gigabit Ethernet Assembly



Quadrax Contact with 8P8C "RJ45" Jack Ethernet Assembly



Quadrax Cable Assembly can be attached to any connector application



Quadrax Cable Assembly attached to Board Level Compliant Quadrax Connector

III  
II  
I  
SJT  
38999

Matrix 2  
26482

Matrix Pyle  
83723 III

Crimp Rear Release Matrix  
5015

26500 Pyle

Printed Circuit Board

EMI Filter Transient

Fiber Optics

High Speed Contacts

Options Others



38999  
SJT I II III

26482  
Matrix 2

83723 III  
Matrix Pyle

5015  
Crimp Rear Release Matrix

26500 Pyle

Printed  
Circuit Board

EMI Filter  
Transient

Fiber Optics

High Speed  
Contacts

Options  
Others

Use the Cable Usage Guide on pages 372-375 as follows:

1. Locate the cable you are using in Cable Type column. For cables not listed consult Amphenol Aerospace.
2. Refer to the Amphenol Connector section which features contacts/adapters for this cable. Connector size, performance features and insert pattern availability may influence your choice.
3. Order your connector and contacts or transition adapters by following the procedure given in the section for the connector series selected. These instructions are supplemented by the Amphenol Catalog Section covering the basic connector.

### Quadrax Contacts CABLE USAGE GUIDE D38999 Series III\* Connectors

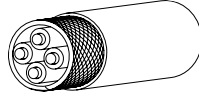

| Cable Type   |                     | Nominal Impedance (ohms) |
|--------------|---------------------|--------------------------|
| Draka Fileca | F-4703-3            | 100                      |
|              | F-4703-4            |                          |
|              | F-4704-5            |                          |
|              | F-47-4-6            |                          |
| Filotex      | ET2PC236            |                          |
|              | ET2PF870            |                          |
| PIC Wire     | E50424              |                          |
|              | E50426              |                          |
|              | E51424              |                          |
|              | NF22Q100            |                          |
| Tensolite    | NF24Q100            |                          |
|              | NF24Q100-1          |                          |
|              | NF24Q100-01-200C    |                          |
|              | NF26Q100            |                          |
|              | NF26Q100-1          |                          |
|              | NF26-2Q100          |                          |
|              | 24443/03130X-4(LD)  |                          |
|              | 24443/03166X-4(LD)  |                          |
|              | 24443/9P025X-4(LD)  |                          |
|              | 23450/04090X-4 (LD) |                          |
|              | 24443/C20714X-4(LD) |                          |
|              | Gore                | RCN7688                  |
|              |                     | RCN8513                  |
| RCN8672      |                     |                          |
| S280W502-4   |                     |                          |
| JSF-18-3     |                     |                          |
| Themax       | 956-4TN             |                          |
|              | 956-5               |                          |
|              | T956-4T200          |                          |
|              | MX100Q-24           |                          |
| Tensolite    | 24450/03089X-4(LD)  |                          |
| Gore         | RCN8487             |                          |
| JSFY02-1     |                     |                          |
| JSF18        |                     |                          |
| Tensolite    | 26473/02006X-4(LD)  |                          |
| Gore         | RCN8328             |                          |

\* Requires modified connector to accommodate keyed contacts.

### Differential Twinax Contacts CABLE USAGE GUIDE D38999 Series III\* Connectors

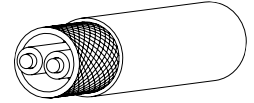

| Cable Type         |                      | Nominal Impedance (ohms) |
|--------------------|----------------------|--------------------------|
| Tensolite          | 26463/70460X-2       | 98                       |
| ST5M1284-003       |                      |                          |
| Draka Fileca       | 2709-3               | 100                      |
| PIC Wire           | E10224               |                          |
| Tensolite          | NF24T100-200C Space  |                          |
|                    | 23460/05114X-2(LD)   |                          |
|                    | 24463/03220T-2(LD)   |                          |
|                    | 24463/05099X-8(LD)   |                          |
|                    | 26453/03184X-2(LD)   |                          |
| 24463/9P025X-2(LD) |                      |                          |
| Raychem            | 0026A0024, 0024G0024 |                          |
| S280W502-6         |                      |                          |
| JSFY11-24          |                      |                          |
| Gore               | GSC-05-827300-00     |                          |
| Thermax            | 956-6262, 956-1T200  |                          |
|                    | 12814                |                          |
|                    | MX 100-24            |                          |
| Tensolite          | 26483/03071X-2(LD)   | 150                      |

### Quadrax Transition Adapters CABLE USAGE GUIDE D38999 Series III\* Connectors or ARINC 600 Connectors

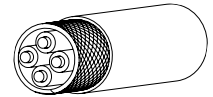

| Cable Type   |                    | Nominal Impedance (ohms) |     |
|--------------|--------------------|--------------------------|-----|
| Draka Fileca | F-4703-3           | 100                      |     |
|              | F-4704-4           |                          |     |
| Tensolite    | NF22Q100           |                          |     |
|              | NF22Q100-01        |                          |     |
|              | NF24Q100           |                          |     |
|              | NF26Q100           |                          |     |
| Thermax      | 956-5              |                          |     |
| Gore         | GSC-10-8273900     |                          |     |
| Tensolite    | 26473/02006X-4(LD) |                          | 150 |

### Differential Twinax Transition Adapters CABLE USAGE GUIDE D38999 Series III\* Connectors or ARINC 600 Connectors

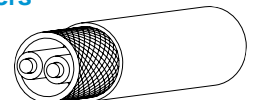

| Cable Type    |                    | Nominal Impedance (ohms) |
|---------------|--------------------|--------------------------|
| M17/176-00002 |                    | 78                       |
| Tensolite     | 224463/9P025X-2    | 100                      |
|               | 24463/9P025X-2(LD) |                          |
| Tensolite     | 26483/03071X-2     | 150                      |

**Quadrax Contacts**  
**CABLE USAGE GUIDE**  
**ARINC 600 Rack & Panel Connectors**



| Cable Type   |                    | Nominal Impedance (ohms) |
|--------------|--------------------|--------------------------|
| Draka Fileca | F-4703-3           | 100                      |
|              | F-4704-5, F4704-4  |                          |
| Tensolite    | NF22Q100           |                          |
|              | NF24Q100           |                          |
|              | 24443/03130X-4(LD) |                          |
|              | 24443/9P025X-4(LD) |                          |
| S280W502-4   |                    |                          |
| JSFY02-1     |                    | 110                      |
| Gore         | RCN8328            | 150                      |
| Tensolite    | 26473/02006X-4(LD) |                          |

**Differential Twinax Contacts**  
**CABLE USAGE GUIDE**  
**ARINC 600 Rack & Panel Connectors**



| Cable Type   |                    | Nominal Impedance (ohms) |
|--------------|--------------------|--------------------------|
| ABS0386WF24  |                    | 100                      |
| ASNE0272TK22 |                    | 100                      |
| ASNE0272TK24 |                    | 100                      |
| Tensolite    | 24463/9P025X-2(LD) | 100                      |

**Concentric Twinax Contacts**  
**CABLE USAGE GUIDE**  
**D38999 Series I, II, III & SJT Connectors**



| Cable Type         |       | Nominal Impedance (ohms) |
|--------------------|-------|--------------------------|
| EPD32263A          |       | 77                       |
| EPD22189B          |       | 77                       |
| M17/176-00002      |       | 77                       |
| GSC-12-2548-00     |       | 77                       |
| GC875TM24H         |       | 77                       |
| GSC-12-81095-00    |       | 77                       |
| Raychem            | 10602 | 77                       |
|                    | 10606 | 77                       |
|                    | 10612 | 77                       |
|                    | 10613 | 77                       |
|                    | 10614 | 77                       |
| 23089/RC           |       | 77                       |
| 05A0771            |       | 77                       |
| T10971             |       | 77                       |
| 7724C8664          |       | 77                       |
| 7726D0664          |       | 77                       |
| 782OD0111 (20 AWG) |       | 78                       |
| 0024G0024          |       | 100                      |
| 5M2022-003         |       | 100                      |
| HS5930             |       | 100                      |
| S280W502-1         |       | 100                      |
| CXN2268            |       | 100                      |

**Triax Contacts**  
**CABLE USAGE GUIDE**  
**D38999 Series I, II, III & SJT Connectors**



| Cable Type           |                  | Nominal Impedance (ohms) |
|----------------------|------------------|--------------------------|
| JN1088WT             |                  | 50                       |
| 5M2397-002           |                  | 75                       |
| 81264-02             |                  | 75                       |
| JN1088WU             |                  | 75                       |
| Gore                 | GSC-03-81497-00  | 75                       |
| RG179 (Coax Cable)   |                  | 75                       |
| Tensolite            | 28988/50823LXX-1 | 75                       |
| Tensolite            | 28988/50823LXX-1 | 75                       |
| Thermatics           | 12447            | 75                       |
| 10602 (Twinax Cable) |                  | 77                       |
| 5M2559-001           |                  | 95                       |
| 81264-01             |                  | 95                       |
| ST5M1323-001         |                  | 95                       |
| Champlain            | 81-00700         | 95                       |
| Tensolite            | 28598/9C026LT-1  | 95                       |
|                      | 26895/90334X-1   | 95                       |
| Teledyne             | 13809            | 95                       |
| 11914/1              |                  | 95                       |
| Times AA6603         |                  | 95                       |

**Concentric Twinax Contacts**  
**CABLE USAGE GUIDE**  
**ARINC 600 Rack & Panel Connectors**



| Cable Type | Nominal Impedance (ohms) |
|------------|--------------------------|
| S280W502-1 | 100                      |

|     |                           |
|-----|---------------------------|
| III | 38999                     |
| II  | 26482                     |
| I   | Matrix 2                  |
| SJT | 83723 III                 |
|     | Matrix                    |
|     | Pyle                      |
|     | 5015                      |
|     | Crimp Rear Release Matrix |
|     | 26500 Pyle                |
|     | Printed Circuit Board     |
|     | EMI Filter Transient      |
|     | Fiber Optics              |
|     | High Speed Contacts       |
|     | Options Others            |

Use the Cable Usage Guides on this page for Coax Contacts as follows:

1. Locate the cable you are using in Cable Type column. For cables not listed consult Amphenol Aerospace.
2. Refer to the Amphenol connector section which features contacts for this cable, as indicated by a • in the appropriate column. If more than one connector series utilizes contacts designed for your cable, investigate each of them. Connector size, performance features and insert pattern availability may influence your choice.
3. Order your connector and coax contact by following the procedure given in the section for the connector series selected. These instructions are supplemented by the Amphenol Catalog Section covering the basic connector.
4. The Additional Contacts column of this guide is used to indicate an additional availability of contact designs for older cable types or capability. Consult Amphenol Aerospace for further information.

### Coax Contacts CABLE USAGE GUIDE



| Cable Type          |                 | Nominal Impedance (ohms) | For Circular (MIL-DTL-38999 type) | For Standard & Heavy Duty Circular (MIL-DTL-5015 type) (MIL-DTL-22992 type) | For Rectangular Connectors | Additional Contacts (Consult Amphenol) |
|---------------------|-----------------|--------------------------|-----------------------------------|---|----------------------------|--|
| RG-5B/U             | (M17/073-RG212) | 50                       |                                   |   |                            | •                                      |
| RG-6A/U             | (M17/2-RG6)     | 75                       |                                   |   |                            | •                                      |
| RG-7/U              |                 | 97                       |                                   |   |                            | •                                      |
| RG-9B/U             | (M17/075-RG214) | 50                       |                                   |   |                            | •                                      |
| RG-11A/U            | (M17/6-RG11)    | 75                       |                                   |   |                            | •                                      |
| RG-12A/U            | (M17/6-RG12)    | 75                       |                                   |   |                            | •                                      |
| RG-13A/U            |                 | 74                       |                                   |   |                            | •                                      |
| RG-21A/U            |                 | 53                       |                                   |   |                            | •                                      |
| RG-55B/U            | (M17/084-RG223) | 53                       |                                   | •   | •                          |  |
| RG-58C/U            | (M17/028-RG058) | 50                       |                                   | •   | •                          |  |
| RG-58               | (M17/155-00001) | 50                       | •                                 |   |                            |  |
| RG-59B/U            | (M17/29-RG59)   | 75                       |                                   | •   |                            |  |
| RG-62A/U            | (M17/030-RG062) | 93                       |                                   | •   |                            |  |
| RG-62B/U            |                 | 93                       |                                   | •   |                            |  |
| RG-63B/U            | (M17/31-RG63)   | 125                      |                                   |   |                            | •                                      |
| RG-71B/U            | (M17/90-RG71)   | 93                       |                                   |   |                            | •                                      |
| RG-87A/U            |                 | 50                       |                                   |   |                            | •                                      |
| RG-115/U            |                 | 50                       |                                   |   |                            | •                                      |
| RG-115A/U           |                 | 50                       |                                   |   |                            | •                                      |
| RG-116/U            |                 | 50                       |                                   |   |                            | •                                      |
| RG-122/U            | (M17/054-RG122) | 50                       |                                   |   | •                          | •                                      |
| RG-133A/U           | (M17/100-RG133) | 95                       |                                   |   |                            | •                                      |
| RG-140/U            | (M17/110-RG302) | 75                       |                                   | •   |                            |  |
| RG-141A/U           |                 | 50                       |                                   | •   | •                          |  |
| RG-142A/U           |                 | 50                       |                                   | •   | •                          | •                                      |
| RG-142B/U           | (M17/060-RG142) | 50                       | •                                 | •   | •                          | •                                      |
| RG-143A/U           |                 | 50                       |                                   |   |                            | •                                      |
| RG-161/U            |                 | 70                       | •                                 | •   |                            |  |
| RG-174A/U           | (M17/119-RG174) | 50                       | •                                 | •   |                            |  |
| RG-178B/U           | (M17/093-RG178) | 50                       | •                                 | •   |                            |  |
| RG-179B/U           | (M17/094-RG179) | 75                       | •                                 | •   |                            |  |
| RG-180B/U           | (M17/095-RG180) | 95                       | •                                 | •   | •                          |  |
| RG-187A/U           | (M17/094-RG179) | 75                       | •                                 | •   |                            |  |
| RG-188A/U           | (M17/113-RG316) | 50                       | •                                 | •   |                            |  |
| RG-188 Double Braid |                 | 50                       |                                   |   |                            |  |
| RG-195A/U           | (M17/095-RG180) | 95                       | •                                 | •   | •                          |  |
| RG-195 Double Braid |                 | 95                       |                                   |   |                            |  |
| RG-196A/U           | (M17/169-00001) | 50                       | •                                 | •   |                            |  |
| RG-210/U            |                 | 93                       |                                   | •   |                            |  |
| RG-212/U            | (M17/073-RG212) | 50                       |                                   | •   |                            | •                                      |
| RG-214/U            | (M17/075-RG214) | 50                       |                                   |   |                            | •                                      |
| RG-216/U            | (M17/77-RG216)  | 75                       |                                   |   |                            | •                                      |
| RG-222/U            |                 | 50                       |                                   |   |                            | •                                      |
| RG-223/U            | (M17/084-RG223) | 50                       | •                                 | •   | •                          |  |
| RG-225/U            | (M17/86-RG225)  | 50                       |                                   |   |                            | •                                      |
| RG-227/U            |                 | 50                       |                                   |   |                            | •                                      |
| RG-302/U            | (M17/110-RG302) | 75                       |                                   | •   |                            |  |

CHART CONTINUES ON NEXT PAGE

NOTE: For information on coax contacts for Miniature circular connectors, MIL-DTL-26482 Series 1, see catalog 12-070 and consult Amphenol Industrial Operations.

NOTE: MIL-DTL-38999 supersedes MIL-C-38999.  
MIL-DTL-5015 supersedes MIL-C-38999.  
MIL-DTL-22992 supersedes MIL-C-22992



## Coax Contacts CABLE USAGE GUIDE, cont.

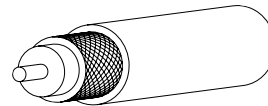

| Cable Type          |                 | Nominal Impedance (ohms) | For Circular (MIL-DTL-38999 type) | For Standard & Heavy Duty Circular (MIL-DTL-5015 type) (MIL-DTL-22992 type) | For Rectangular Connectors | Additional Contacts (Consult Amphenol) |
|---------------------|-----------------|--------------------------|-----------------------------------|---|----------------------------|--|
| RG-303/U            | (M17/111-RG303) | 50                       |                                   | •   | •                          |  |
| RG-304/U            | (M17/112-RG304) | 50                       |                                   |   |                            | •                                      |
| RG-316/U            | (M17/113-RG316) | 50                       | •                                 | •   |                            |  |
| RD-316 Double Braid | (M17/152-00001) | 50                       | •                                 |   |                            |  |
| RG-400              | (M17/128-RG400) | 50                       | •                                 |   |                            |  |
| M/A-COM 5M2869-001  |                 | 50                       | •                                 |   | •                          |  |
| 5022A1311-D         |                 | 50                       | •                                 |   |                            |  |
| Beldon 9307         |                 | 50                       | •                                 |   |                            |  |
| FA-19X              |                 | 50                       | •                                 |   |                            |  |
| T-Flex-402          |                 | 50                       | •                                 |   |                            |  |
| T-Flex-405          |                 | 50                       | •                                 |   |                            |  |
| Filotex ET124962    |                 | 50                       | •                                 |   |                            |  |
| JN1088WT            | (Triax)         | 50                       | •                                 |   |                            |  |
| JN1088WU            | (Triax)         | 75                       | •                                 |   |                            |  |
| PAN6422XQ           |                 | 50                       | •                                 |   |                            |  |
| PAN6422XY           |                 | 75                       | •                                 |   |                            |  |
| PAN6595XM           | (Triax)         | 75                       | •                                 |   |                            |  |
| Haveg               | 51-04486        |                          | •                                 |   |                            |  |
|                     | 81-00207        |                          | •                                 |   |                            |  |
| Gore                | GWN1159A        |                          | •                                 |   |                            |  |
|                     | CXN3403         |                          | •                                 |   |                            |  |
| Times               | AA3248          |                          | •                                 |   |                            |  |
| Teledyne            | 11299           |                          | •                                 |   |                            |  |
| Raychem             | 5021D1331-0     | 50                       | •                                 |   |                            |  |
|                     | 5021D1331-9     | 50                       | •                                 |   |                            |  |
|                     | 5022D1312-9     | 50                       | •                                 |   |                            |  |
|                     | 7527A1318       | 75                       | •                                 |   |                            |  |
|                     | 9527A1314       | 95                       | •                                 |   |                            |  |
|                     | 9528A1318       | 95                       | •                                 |   |                            |  |
|                     | 9530A5314       | 95                       | •                                 |   |                            |  |
| 9530D5314           | 95              | •                        |                                   |   |                            |  |
| Thermatics          | 2929-29         |                          | •                                 |   |                            |  |
| Tensolite           | 30850/87T-1     |                          | •                                 |   |                            |  |
| Thermax             | 50C-25A-DS-1    |                          | •                                 |   |                            |  |
|                     | ESC352001       | 50                       | •                                 |   |                            |  |
|                     | ESC432101       | 50                       | •                                 |   |                            |  |

For Cable not found in the Coax Contact Cable Usage Guide, refer to these general dimensional ranges:  
(In general, for D38999 Connectors, the size 8, 12 and 16 Coax Contacts will terminate cable in the following ranges )

### SIZE 16

|  |
|--|
| .012 / .0215 Center Conductor (Stranded)                   |
| .031 / .066 Dielectric                                     |
| .085 Max Outer braid (must be round for crimp termination) |
| .102 Max. Jacket   |

### SIZE 12

|  |
|--|
| .012 / .0215 Center Conductor (Stranded)                   |
| .031 / .105 Dielectric                                     |
| .126 Max Outer braid (must be round for crimp termination) |
| .145 Max. Jacket   |

### SIZE 8

|  |
|--|
| .012 / .0395 Center Conductor (Stranded)                   |
| .055 / .133 Dielectric                                     |
| .180 Max Outer braid (must be round for crimp termination) |
| .201 Max. Jacket   |

Special coax contacts may be available for cables outside of ranges shown. Consult Amphenol Aerospace for further assistance in selection of coax contact cables.

38999  
III  
II  
I  
SJT

26482  
Matrix 2

83723 III  
Matrix  
Pyle

5015  
Crimp Rear  
Release Matrix

26500 Pyle

Printed  
Circuit Board

EMI Filter  
Transient

Fiber Optics

High Speed  
Contacts

Options  
Others

38999  
SJT I II III

26482  
Matrix 2

83723 III  
Matrix Pyle

5015  
Crimp Rear Release Matrix

26500 Pyle

Printed  
Circuit Board

EMI Filter  
Transient

Fiber Optics

High Speed  
Contacts

Options  
Others

Amphenol® Connectors are ideally suited for the incorporation of shielded contacts for high performance interconnection applications. The circular family is built around MIL-DTL-38999 specifications, with Mil-approved and commercial styles offered. Normal operating voltage for circulars with power contacts only is up to 900 VAC (RMS) at sea level.

**The MIL-DTL-38999 family offer these features for contact termination flexibility:**

- Widest selection of insert arrangements that can incorporate:
  - Size 8 high speed Quadrax and Differential Twinax contacts for MIL-DTL-38999 Series III (specially modified to accommodate keyed contacts)
  - Transition adapters for use in attaching D38999 Series III connectors with high speed quadrax or differential contacts to PCB boards
  - Size 8, 12 and 16 Coax contacts
  - Size 8 and 12 Twinax contacts
  - Size 8, 10 & 12 Triax contacts
- Wide selection of connector shell styles and sizes
- Scoop-Proof recessed design in LJT-R, TV-R and SJT-R connectors provide protection for contacts
- Standard power contacts are crimp rear release, qualified to SAE AS39029
- Coax, Twinax, and Triax contacts employ the same retention system as power contacts, simplifying user substitution

**GENERAL ORDERING INFORMATION**

Amphenol MIL-DTL-38999, which feature rear removable contacts, are normally supplied with a full complement of power contacts, separately packaged. Coax, twinax and triax contacts are ordered by part number as referenced in the part number charts on the following pages of this catalog, and are substituted for the power contacts at the time of the cable or equipment assembly. If the application is for coax, twinax or triax contacts only, the connector may be ordered *less contacts* and no power contacts will be supplied.

**HOW TO ORDER CONNECTORS AND HIGH FREQUENCY CONTACTS**

- Select the Circular Series desired.  
(See features of each series given briefly on this page and in-depth in the other sections of this catalog, which are on-line at [www.amphenol-aerospace.com](http://www.amphenol-aerospace.com)).
- Series I - LJT-R Connectors
- Series II - JT-R Connectors
- Series III - TV-R Connectors
- SJT\* - SJT-R Connectors
- See Amphe-Lite (Industrial 38999 type) Catalog 12-094
- Select the quadrax, differential twinax, coax, twinax and/or triax contacts or the transition adapters that are needed from the tables on the following pages that correspond to the cable being used.
- Select the insert arrangement to accommodate required number of contacts. Insert patterns for quadrax and differential twinax contacts are on pages 387,388. Insert patterns for coax, twinax and triax contacts are on pages 404-406.
- Complete the connector part number from the connector series catalog, incorporating the chosen insert pattern number. See detailed how to order page 389 for ordering 38999, Series III with quadrax and differential twinax contacts. Consult Amphenol for assistance in ordering 38999 circulars with coax, twinax and triax contacts.
- Consult Amphenol Aerospace for ordering information for connectors with PC tail contacts, and for transition adapters.
- If connector is ordered less contacts, power contacts and/or sealing plugs may be ordered separately to fill out the insert arrangement.



TV-R, Tri-Start, D38999 Series III

- High performance capability series for both general duty and severe environment applications
  - Offers the widest range of Subminiature Family Mil-Spec qualified options in contact and connector styles
  - Threaded coupling; completely mates in one turn; crimp termination
  - Superior EMI/EMP shielding effectiveness
  - Scoop-proof design (recessed pins)
  - Available in aluminum, stainless steel and firewall, or lightweight composite styles
- See 38999 section Series III for complete information on this section.



JT-R, D38999 Series II

- See 38999 section Series II, JT for complete information on this series.
- Shorter profile connector series for applications requiring maximum space savings
  - Bayonet coupling, crimp termination
  - Also available in solder termination types under MIL-DTL-27599 Series II



LJT-R, D38999 Series I

- See 38999 section Series I, LJT for complete information on this series.
- Scoop-proof (recessed pins)
  - Bayonet coupling, crimp termination
  - Also available in solder termination types under MIL-DTL-27599 Series II



Amphe-Lite, 38999 Type

- See Catalog 12-094 for complete information on this series.
- Commercial/Industrial 38999 Series III type
  - Cost effective high performance connector for severe environments or general duty industrial applications
  - Consult Amphenol Industrial Operations for further information 12-094 catalog is on-line at [www.amphenol-industrial.com](http://www.amphenol-industrial.com).



SJT-R, 38999 Type

- See the SJT section of this catalog.
- Amphenol proprietary series (non-MS) which is a further expansion of the basic JT family, but incorporates the LJT scoop-proof design
  - Compliant with several European specifications

NOTE: SAE AS39029 supersedes MIL-C-39029.  
NOTE: MIL-DTL-38999 supersedes MIL-C-38999.  
MIL-DTL-27599 supersedes MIL-C-27599

# Quadrax Contacts, MIL-DTL-38999, Series III

## General Description



**Amphenol® Quadrax Contacts** -offer several advantages for high data transfer rates, low power consumption and excellent EMI compatibility:

- Four strategically spaced inner contacts form two 100 or 150 Ohm matched impedance differential pairs
- Outer contact has rugged wall section for durability
- Available in size 8 crimp termination style
- Also available in size 8 with PC tails (see page 379)
- Requires modification of MIL-DTL-38999 connector to accommodate keyed contacts

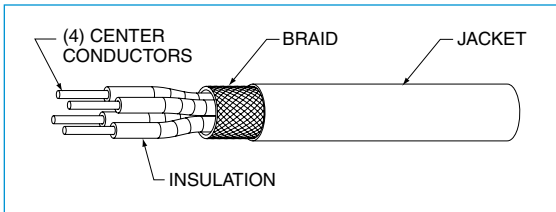

Cable Illustration - Quadrax Contact

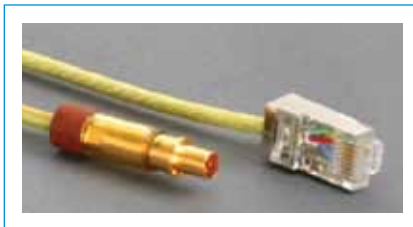
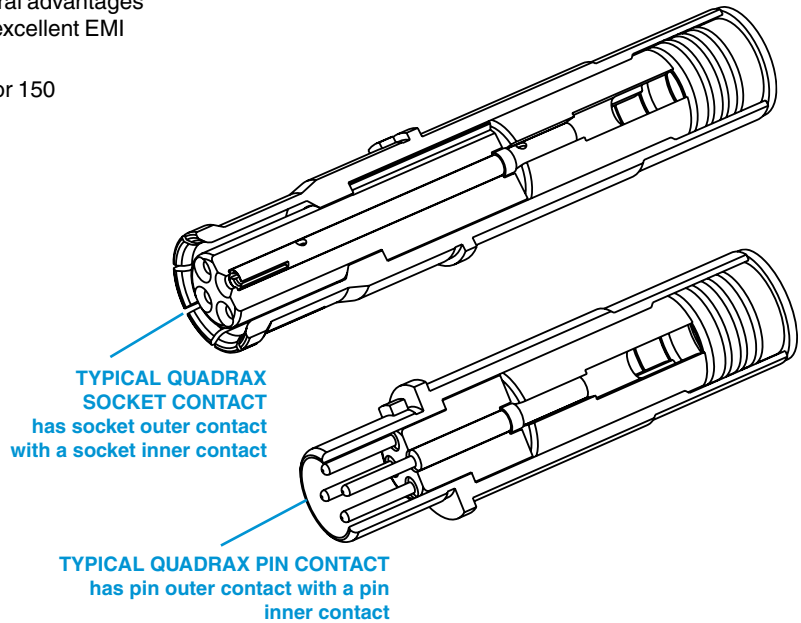

Quadrax Pin with 8P8C "RJ45" Jack



Quadrax Pin Size 8 and MIL-DTL-38999 Series III Connector

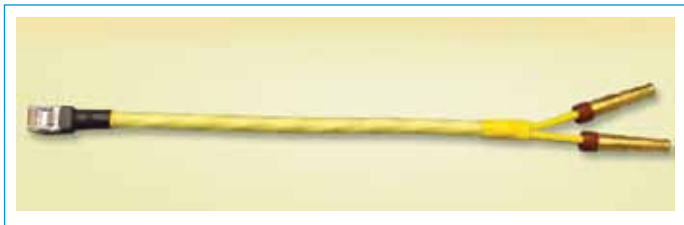

Quadrax in an Eight Wire Gigabit Ethernet Assembly

### Suggested Strain Relief - Insert Arrangements 9-5 or 19-18 with Quadrax Contacts

Due to the piggyback grommet interference with normal strain reliefs on the shell size 9 only, the recommended strain relief for the connector is: Amphenol part number TGW-R-5309-10 (OD Cad) or TGF-R-5309-10 (Electroless nickel)

- shell size 9 only. For 19-18 insert pattern, recommended backshell: Glenair 367-221-NF. This is recommended due to the proximity of the size 8 contacts in relation to the shell.

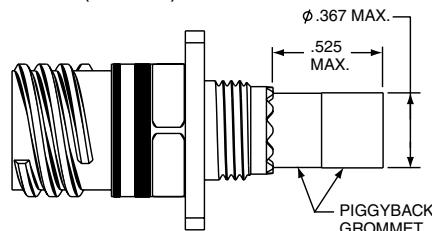

Also see Quadrax contacts for ARINC 600 and R27 Rack and Panel Connectors on page 411 and 412.

### Quadrax Contacts are gold plated, crimp termination

Finish of mating contacts parts: supplied with 0.000050 min. gold over nickel on mating parts. Consult Amphenol for availability of other finishes.

### Quadrax Size 8 Contact Performance:

- Bandwidth: Up to 3 Gigahertz
- Data Rate: Exceeding 3 Gbits/sec.
- Voltage Rating: 500 Vrms max. @ sea level
- Dielectric Withstanding Voltage: 1000 VAC rms between all inner contacts @ sea level, 500 VAC rms between inner and outer contacts @ sea level

### Suggested Numbering for Quadrax Contacts

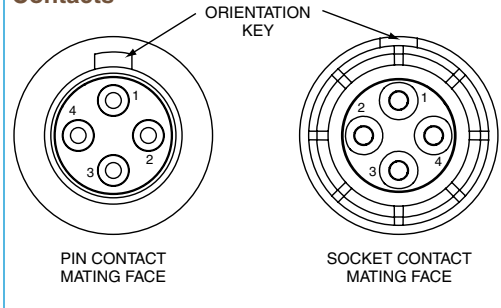

Differential Pairs, contacts 1-3, 2-4.

See page 389 for part number ordering of popularly used 38999 Series III connectors with 100 ohm quadrax contacts.

Quadrax differential pairs are 1 and 3, 2 and 4.

III  
II  
I  
SJT  
38999

Matrix 2  
26482

Matrix Pyle  
83723 III

Crimp Rear Release Matrix  
5015

26500 Pyle

Printed Circuit Board

EMI Filter Transient

Fiber Optics

High Speed Contacts

Options Others

### TV-R Series, MIL-DTL-38999 Series III\* Connectors

#### QUADRAX CONTACTS FOR USE IN TV-R CONNECTORS

| Cable   | Contact Part Number<br>(Termination Instruction Sheet)** |                             | Impedance<br>(Ohms) | Inner Conductor<br>(AWG) | Contact Size        | Electrical Protocol††                                      | Crimping Tools  |   |
|---|--|-----------------------------|---------------------|--------------------------|---------------------|--|---|---|
|   | Pin  | Socket                      |                     |                          |                     |  | Inner Contact   | Outer Contact                                     |
| Draka Fileca F-4703-3, F4704-4, Filotex ET 2PC236, Filotex ET2PF870, PIC Wire E50424 ABS0972, Tensolite 23450/04090X-4(LD)  | 21-33384-21<br>(L-2119-A)                                | 21-33385-21<br>(L-2119-A)   | 100                 | 24                       | 8                   | Ethernet, 1000 Base-T Gigabit Ethernet                     | M22520/2-01 with Positioner M22520/2-37 or with Daniels Positioner K709 | M22520/5-01 with Die Set M22520/5-45 (Location A) |
| Tensolite NF24Q100, NF24Q100-01, 24443/9P025X-4(LD), S280W502-4, 24443/03130X-4(LD), 24443/C20714X-4(LD), 24450/0120X-4(LD), NF24-2Q100, TYCO CEC-RWC-18664, GORE GSC-01-81869-01, 24443/03166X-4(LD), Thermax T956-4T200, Pic Wire E51424, Thermax MX100Q-24, NF24Q100-01-200C (Space) | 21-33384-51<br>(L-2119-D)                                | 21-33385-51<br>(L-2119-D)   |                     | 24                       |                     | Ethernet, 1000 Base-T Gigabit Ethernet                     |   |   |
| Tensolite NF22Q100, NF22Q100-01, Thermax 956-5, GORE RCN 7688 Draka Fileca F-4704-5, ABS1503 KD 24  | 21-33384-61<br>(L-2119-H)                                | 21-33385-61<br>(L-2119-H)   |                     | 22                       |                     | Ethernet (100 Mbps), 1000 Base-T Gigabit Ethernet (1 Gbps) |   |   |
| Tensolite NF26Q100, NF26Q100-01, NF26-2Q100, PIC E51426   | 21-33384-71<br>(L-2119-AB)                               | 21-33385-71<br>(L-2119-AB)  |                     | 26                       |                     | Ethernet (100 Mbps), 1000 Base-T Gigabit Ethernet (1 Gbps) |   |   |
| Draka Fileca F-4704-6, Gore RCN 8672  | 21-33384-151<br>(L-2119-AW)                              | 21-33385-151<br>(L-2119-AW) |                     | 26                       |                     | Ethernet (100 Mbps), 1000 Base-T Gigabit Ethernet (1 Gbps) |   |   |
| Tensolite NF24Q100-01 (same as 21-3338( ) -51, uses EMI Piggyback)  | 21-33384-161<br>(L-2119-BE)                              | 21-33385-161<br>(L-2119-BE) |                     | 24                       |                     | Ethernet (100 Mbps), 1000 Base-T Gigabit Ethernet (1 Gbps) |   |   |
| Gore RCN8513, JSFY18-3  | 21-33384-171<br>(L-2119-BN)                              | 21-33385-171<br>(L-2119-BN) |                     | 22                       |                     | Ethernet (100 Mbps), 1000 Base-T Gigabit Ethernet (1 Gbps) |   |   |
| Tensolite NF22Q100 Special Box pattern, only mates with 21-333( ) -181  | 21-33384-181<br>(L-2119-BP)                              | 21-33384-181<br>(L-2119-BP) |                     | 22                       |                     | Ethernet (100 Mbps), 1000 Base-T Gigabit Ethernet (1 Gbps) |   |   |
| Tensolite NF24Q100, NF24Q100-01 for 2.5 Gbps applications   | 21-33384-191<br>(L-2119-BS)                              | 21-33385-191<br>(L-2119-BS) |                     | 24                       |                     | Serial FPD Applications (2.5 Gbps)                         |   |   |
| USB2 (28433/02171LX-4)  | 21-33384-101†  | 21-33385-101†               |                     | 90                       |                     | USB2.0 (480 Mbps)  |   |   |
| Tensolite 24450/03089X-4(LD)  | 21-33384-211   | 21-33385-211                | 110                 | 24                       | IEEE 1394B Firewire |  |   |   |
| JSFY02-1, JSFY18  | 21-33384-221   | 21-33385-221                |                     | 24                       | IEEE 1394B Firewire |  |   |   |
| Gore RCN8487, JSFY18  | 21-33384-231   | 21-33385-231                |                     | 24                       | IEEE 1394B Firewire |  |   |   |
| Tensolite 24450/03089X-4(LD) Same as 21-3338( )-211 but Box pattern, mates with 21-3338( )-241 only   | 21-33384-241†  | 21-33385-241†               |                     | 24                       | IEEE 1394B Firewire |  |   |   |
| Tensolite 26473/02006X-4(LD)/Gore RCN8328 (not for new designs, use 21-33450/1 series)  | 21-33384-31<br>(L-2119-B)                                | 21-33385-31<br>(L-2119-B)   | 150                 | 26                       |                     |  |   |   |

CHART CONTINUES ON NEXT PAGE

#### QUADRAX CONTACT DATA

Contacts are inserted by hand. Refer to termination instructions listed. Contacts are removed with a removal tool. Recommended tool is MIL-I-81969/14-06, Daniels DRK-264-8. Refer to termination instructions listed.

Finish of mating contact parts: Contact part numbers shown in the chart above are supplied gold plated per ASTM B488 Type II, Code C, .000050 min. thick over nickel plate per AMS-QQ-N-290, Class 2, .000030/.000150 thick.

CONTACT ORDERING: Example number given in chart 21-33384-21 should be ordered as 21-033384-021; example number 21-33384-151 should be ordered as 21-033384-151. Adding Zeros is necessary for Amphenol ordering process on all contact numbers  
Daniels crimping tools are available from Daniels Mfg. Corp. 6103 Anno Ave., Orlando, FL 32809

\* Requires modified connector to accommodate keyed contacts.  
\*\*Termination instructions are packaged with each contact and can be found on-line at: [www.amphenol-aerospace.com/serviceinstructions.asp](http://www.amphenol-aerospace.com/serviceinstructions.asp)  
† Consult Amphenol Aerospace for current release of this contact or instruction sheet if applicable.  
†† Test reports available for indicated protocols. Consult Amphenol Aerospace.



### TV-R Series, MIL-DTL-38999 Series III\* Connectors

| QUADRAX CONTACTS FOR USE IN TV-R CONNECTORS   |  |                             |                     |                             |                 |  |   |   |
|---|--|-----------------------------|---------------------|-----------------------------|-----------------|--|---|---|
| Cable   | Contact Part Number<br>(Termination Instruction Sheet)** |                             | Impedance<br>(Ohms) | Inner<br>Conductor<br>(AWG) | Contact<br>Size | Electrical<br>Protocol††   | Crimping Tools  |   |
|   | Pin  | Socket                      |                     |                             |                 |  | Inner<br>Contact  | Outer<br>Contact                                  |
| Tensolite 26473/02006X-4(LD) Same as 21-33384/5-31 but box pattern (not for new designs, use 21-33450/1 series)     | 21-33384-201†  | 21-33385-201†               | 150                 | 26                          | 8               | Fibre-Channel (1 GBPS, 2 GBPS, 1G/2G), 1000 Base-CX (1.25 GBPS), SCSI-2 (3.2 GBPS) | M22520/2-01 with Positioner M22520/2-37 or with Daniels Positioner K709 | M22520/5-01 with Die Set M22520/5-45 (Location A) |
| Tensolite 26473/02006X-4(LD), Gore RCN8328  | 21-33450-001<br>(L-2119-BW)                              | 21-33451-001<br>(L-2119-BW) |                     | 26                          |                 |  |   |   |
| Tensolite 26473/02006X-4(LD), Gore RCN8328 (same as 21-33450/1-1 except box pattern. Mates with 21-33450/1-11 only. | 21-33450-011†  | 21-33451-011†               |                     | 26                          |                 |  |   |   |

| PCB QUADRAX CONTACTS FOR USE IN TV-R CONNECTORS              |                     |              |                     |                 |
|--|---------------------|--------------|---------------------|-----------------|
| PCB Quadrax<br>Contacts                                      | Contact Part Number |              | Impedance<br>(Ohms) | Contact<br>Size |
|  | Pin                 | Socket       |                     |                 |
| PCB (.866 Length) Pre-tinned tails                           | 21-33398-21         | 21-33397-21  | 100                 | 8               |
| PCB (.866 Length)  | 21-33398-31         | 21-33397-31  | 100                 |                 |
| PCB Right Angle, inner contacts box pattern                  | 21-33425-1          |              | 100                 |                 |
| PCB (.494 Length) Pre-tinned tails                           | 21-33398-71         |              | 150                 |                 |
| PCB (1.194 Length) Pre-tinned tails                          | 21-33398-101        |              | 100                 |                 |
| PCB (.859 Length)  | 21-33398-121        |              | 100                 |                 |
| PCB (.741 Length)  | 21-33398-271†       |              | 100                 |                 |
| PCB (1.035 Length)   | 21-33398-291        | 21-33397-291 | 100                 |                 |
| PCB (.836 Length)  |                     | 21-33397-301 | 150                 |                 |
| PCB (1.035 Length) Pre-tinned tails                          | 21-33398-61         | 21-33397-61  | 150                 |                 |
| PCB (1.035 Length) mates to 21-33451 series                  | 21-33452-11†        |              | 150                 |                 |
| PCB (1.035 Length) mates to 21-33450 series                  |                     | 21-33453-11† | 150                 |                 |
| PCB (.815 Length) mates to 21-33451 series                   | 21-33452-21†        |              | 150                 |                 |
| PCB (.815 Length) mates to 21-33450 series                   |                     | 21-33453-21† | 150                 |                 |
| PCB (.815 Length) Pre-tinned tails, mates to 21-33451 series | 21-33452-31†        |              | 150                 |                 |
| PCB (.815 Length) Pre-tinned tails, mates to 21-33450 series |                     | 21-33453-31† | 150                 |                 |
| PCB (.866 Length) mates to 21-33451 series                   | 21-33452-41†        |              | 150                 |                 |
| PCB (.866 Length) mates to 21-33450 series                   |                     | 21-33453-41† | 150                 |                 |
| PCB (.494 Length) mates to 21-33451 series                   | 21-33452-51†        |              | 150                 |                 |
| PCB (.494 Length) mates to 21-33450 series                   |                     | 21-33453-51† | 150                 |                 |
| PCB (.840 Length) Pre-tinned tails                           | 21-33398-81         |              | 150                 |                 |
| PCB (.780 Length) Pre-tinned tails                           | 21-33398-131        |              | 150                 |                 |
| PCB (.840 Length) Pre-tinned tails                           | 21-33398-91         |              | 100                 |                 |
| PCB (.708 Length)  | 21-33398-111        |              | 100                 |                 |
| PCB (.605 Length)  | 21-33398-191        |              | 100                 |                 |
| PCB (.494 Length)  | 21-33398-231        |              | 100                 |                 |
| PCB (.741 Length)  | 21-33398-241        | 21-33397-241 | 100                 |                 |
| PCB (.806 Length)  | 21-33398-281        |              | 100                 |                 |
| PCB (.940 Length)  | 21-33398-311        |              | 100                 |                 |
| PCB (.939 Length)  | 21-33398-361        |              | 100                 |                 |
| PCB (.672 Length)  | 21-33398-371        |              | 100                 |                 |
| PCB (.914 Length)  | 21-33398-381        |              | 100                 |                 |
| PCB (.866 Length)  | 21-33398-411        |              | 100                 |                 |
| PCB (.901 Length)  |                     | 21-33397-341 | 100                 |                 |
| PCB (.871 Length)  |                     | 21-33397-351 | 100                 |                 |
| PCB (1.169 Length)   |                     | 21-33397-421 | 100                 |                 |

CONTACT ORDERING: Example number given in chart above 21-33384-201 should be ordered as 21-033384-201; example number given in chart at left 21-33398-21 should be ordered as 21-033398-021. Adding Zeros is necessary for Amphenol ordering process on all contact numbers

Daniels crimping tools are available from Daniels Mfg. Corp. 6103 Anno Ave., Orlando, FL 32809

\* Requires modified connector to accommodate keyed contacts.

\*\*Termination instructions are packaged with each contact and can be found on-line at: [www.amphenol-aerospace.com/serviceinstructions.asp](http://www.amphenol-aerospace.com/serviceinstructions.asp)

† Consult Amphenol Aerospace for current release of this contact or instruction sheet if applicable.

†† Test reports available for indicated protocols. Consult Amphenol Aerospace.

| SEALING PLUGS   |              |
|---|--------------|
| Sealing Plugs for use with D38999 Connectors using Quadrax Contacts - Size 8 Cavities | Part Number  |
| Standard Plastic  | T3-4008-59P  |
| Standard Plastic to be used with PCB tails (shorter tail length)                      | T3-4008-59P1 |
| Metal sealing plug - can be used when mating with contacts on mating half             | 21-33899-8Q1 |
| Metal sealing plug used with PCB's and mating contact on mating half                  | 21-33899-8Q2 |

| PIGGYBACK GROMMET   |             |
|---|-------------|
| Grommet for use with D38999 Connectors using Quadrax Contacts | Part Number |
| Metallized piggyback grommet                                  | 21-33321-23 |

Indicated length given in chart at left is the distance from the rear of the contact retention shoulder to the tip of the PCB tails.



Note: it does not indicate stickout length when installed in D38999 connector.

III  
II  
I  
SJT  
38999

Matrix 2  
26482

Matrix  
Pyle  
83723 III

Release Matrix  
Crimp Rear  
5015

26500 Pyle

Printed  
Circuit Board

EM I Filter  
Transient

Fiber Optics

High Speed  
Contacts

Options  
Others

38999  
SJT I II III

26482  
Matrix 2

83723 III  
Matrix Pyle

5015  
Crimp Rear  
Release Matrix

26500 Pyle

Printed  
Circuit Board

EMI Filter  
Transient

Fiber Optics

High Speed  
Contacts

Options  
Others

**Amphenol® Differential Twinax Contacts -**

Offer several advantages for high data transfer rates, low power consumption and excellent EMI compatibility:

- Two strategically spaced inner contacts form two 100 or 150 Ohm matched impedance differential pairs
- Outer contact has rugged wall section for durability
- Available in size 8 crimp termination style
- Also available in size 8 with PC tails (see page 381)
- Requires modification of MIL-DTL-38999 connector to accommodate keyed contacts

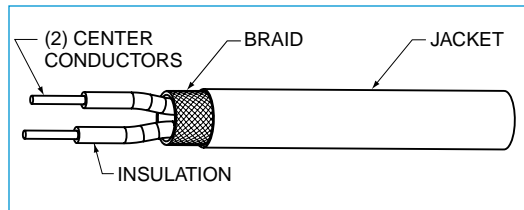

Cable Illustration - Differential Twinax Contact

**TYPICAL DIFFERENTIAL TWINAX SOCKET CONTACT** has socket outer contact with a socket inner contact

**TYPICAL DIFFERENTIAL TWINAX PIN CONTACT** has pin outer contact with a pin inner contact

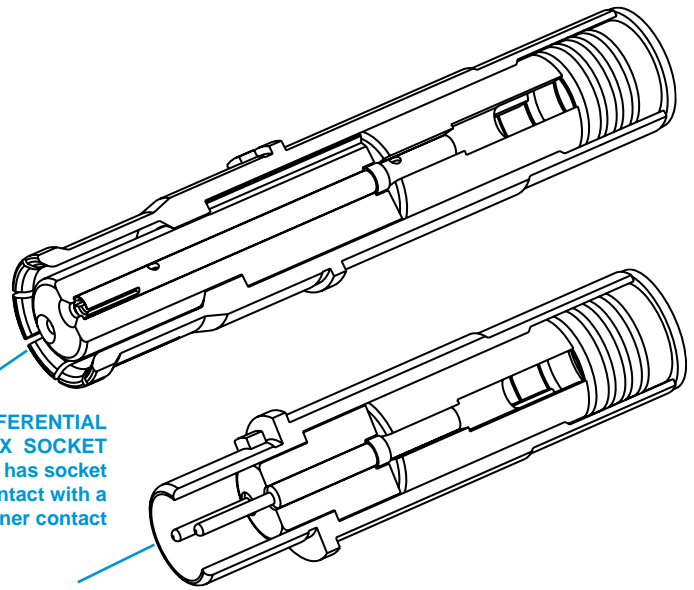

Differential Twinax Socket Contact

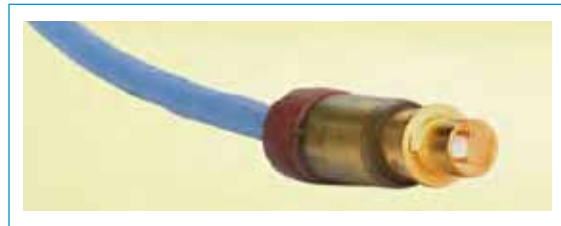

Differential Twinax Pin Contact

**Differential Twinax Contacts are Gold plated, Crimp Termination**

Finish of mating contacts parts: supplied with 0.000050 min. gold over nickel on mating parts. Consult Amphenol for availability of other finishes.

**Differential Twinax Size 8 Contact Performance:**

- Bandwidth: Up to 3 Gigahertz
- Data Rate: Exceeding 3 Gbits/sec.
- Voltage Rating: 500 Vrms max. @ sea level
- Dielectric Withstanding Voltage: 1000 VAC rms between all inner contacts @ sea level 500 VAC rms between inner and outer contacts @ sea level

**Suggested Numbering for Differential Twinax Contacts**

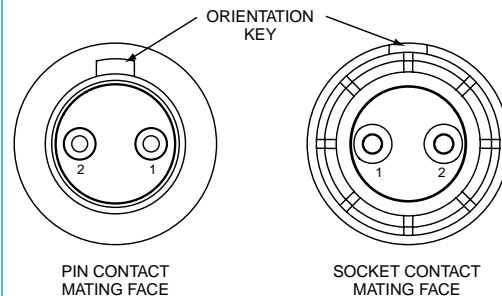



## TV-R Series, MIL-DTL-38999 Series III\* Connectors

| DIFFERENTIAL TWINAX CONTACTS FOR USE IN TV-R CONNECTORS  |  |                               |                     |                 |                                      |   |   |
|--|--|-------------------------------|---------------------|-----------------|--------------------------------------|---|---|
| Cable  | Contact Part Number<br>(Termination Instruction Sheet)** |                               | Impedance<br>(Ohms) | Contact<br>Size | Electrical<br>Protocol††             | Crimping Tools  |   |
|  | Pin  | Socket                        |                     |                 |                                      | Inner<br>Contact  | Outer<br>Contact                                  |
| Tensolite 24463/05099X-8(LD), Thermax MX 100-24, Tensolite 24463/9P025X-2(LD), Thermax 12814, ST5M1284-003 (98 Ohm), 26463/70460X-2 (98 Ohm), PIC E10224, Fileca 2709-3, NF24T100-200C (Space), S280W502-1 | 21-33387-21<br>(L-2119-E)                                | 21-33388-21<br>(L-2119-E)     | 100                 | 8               | Ethernet, USB                        | M22520/2-01 with Positioner M22520/2-37 or with Daniels Positioner K709 | M22520/5-01 with Die Set M22520/5-45 (Location A) |
| GORE GSC-05-827300-00  | 21-33387-51***<br>(L-2119-AY)                            | 21-33388-51***<br>(L-2119-AY) |                     |                 |                                      |   |   |
| Tensolite 26453/03184X-2(LD), Thermax 956-626Z, GORE GSC-05-827300-00  | 21-33387-41<br>(L-2119-T)                                | 21-33388-41<br>(L-2119-T)     |                     |                 |                                      |   |   |
| 23460/05114X-2(LD), PIC E1024  | 21-33387-61<br>(L-2119-BH)                               | 21-33388-61<br>(L-2119-BH)    |                     |                 |                                      |   |   |
| Raychem 0026A0024, M17/176-00002 (77 Ohm)  | 21-33387-71<br>(L-2119-BJ)                               | 21-33388-71<br>(L-2119-BJ)    |                     |                 |                                      |   |   |
| JSFY11-24, Tensolite 24463/03220T-2(LD), Thermax 956-1T200   | 21-33387-91<br>(L-2119-BT)                               | 21-33388-91<br>(L-2119-BT)    |                     |                 |                                      |   |   |
| S280W502-6, Tensolite 24463/9P026X-2(LD)   | 21-33387-101<br>(L-2119-AK)                              | 21-33388-101<br>(L-2119-AK)   | 150                 |                 | Fibre Channel, 1000 Base-CX Ethernet |   |   |
| Tensolite 26483/03071X-2(LD)   | 21-33387-31<br>(L-2119-AC)                               | 21-33388-31<br>(L-2119-AC)    |                     |                 |                                      |   |   |
| Tensolite 26483/03071X-2(LD)   | 21-33456-1<br>(L-2119-BX)†                               | 21-33457-1<br>(L-2119-BX)†    |                     |                 |                                      |   |   |

| PCB DIFFERENTIAL TWINAX CONTACTS FOR USE IN TV-R CONNECTORS |                     |              |                     |                 |
|---|---------------------|--------------|---------------------|-----------------|
| PCB Quadrx<br>Contacts                                      | Contact Part Number |              | Impedance<br>(Ohms) | Contact<br>Size |
|   | Pin                 | Socket       |                     |                 |
| PCB (1.035 Length)  | 21-33834-1          | 21-33835-1   | 100                 | 8               |
| PCB (.788 Length)   | 21-33834-31         | 21-33835-31  |                     |                 |
| PCB (.494 Length)   | 21-33834-41         | 21-33835-41  |                     |                 |
| PCB (.939 Length)   | 21-33834-51         | 21-33835-51  |                     |                 |
| PCB (.780 Length)   | 21-33834-61         | 21-33835-61  |                     |                 |
| PCB (.871 Length)   | 21-33834-71         | 21-33835-71  |                     |                 |
| PCB (.937 Length)   | 21-33834-81         | 21-33835-81  |                     |                 |
| PCB (1.035 Length)  | 21-33834-91         | 21-33835-91  |                     |                 |
| PCB (.843 Length)   | 21-33834-101        | 21-33835-101 |                     |                 |
| PCB (.806 Length)   | 21-33834-111        | 21-33835-111 |                     |                 |
| PCB (.908 Length)   | 21-33834-121        | 21-33835-121 |                     |                 |
| PCB (.530 Length)   | 21-33834-131        | 21-33835-131 |                     |                 |
| PCB (.819 Length)   | 21-33834-141        | 21-33835-141 |                     |                 |
| PCB (1.035 Length)  | 21-33834-21         | 21-33835-21  |                     |                 |
| PCB (1.035 Length) mates to 21-33456/57 series              | 21-33458-001        | 21-33457-001 | 150                 |                 |

### DIFFERENTIAL TWINAX CONTACT DATA

Contacts are inserted by hand. Refer to termination instructions listed.  
 Contacts are removed with a removal tool. Recommended tool is MIL-I-81969/14-06, Daniels DRK-264-8. Refer to termination instructions listed.

Finish of mating contact parts: Contact part numbers shown in the chart above are supplied gold plated per ASTM B488 Type II, Code C, .000050 min. thick over nickel plate per AMS-QQ-N-290, Class 2, .000030/.000150 thick.

CONTACT ORDERING: Example number given in chart above 21-33387-21 should be ordered as 21-033387-021; example number given in chart left 21-33834-1 should be ordered as 21-033834-001. Adding Zeros is necessary for Amphenol ordering process on all contact numbers Daniels crimping tools are available from Daniels Mfg. Corp. 6103 Anno Ave., Orlando, FL 32809

\* Requires modified connector to accommodate keyed contacts.

\*\*\* Indicated contact is vacuum degassed

†† Test reports available for indicated protocols. Consult Amphenol Aerospace.

\*\*Termination instructions are packaged with each contact and can be found on-line at:

[www.amphenol-aerospace.com/serviceinstructions.asp](http://www.amphenol-aerospace.com/serviceinstructions.asp)

† Consult Amphenol Aerospace for current release of this instruction sheet.

Indicated length given in chart at left is the distance from the rear of the contact retention shoulder to the tip of the PCB tails.

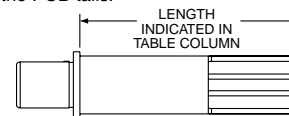

Note: it does not indicate stickout length when installed in D38999 connector.

38999  
III  
II  
I  
SJT

26482  
Matrix 2

83723 III  
Matrix  
Pyle

5015  
Crimp Rear  
Release Matrix

26500 Pyle

Printed  
Circuit Board

EMI Filter  
Transient

Fiber Optics

High Speed  
Contacts

Options  
Others

38999  
SJT I II III

26482  
Matrix 2

83723 III  
Matrix Pyle

5015  
Crimp Rear  
Release Matrix

26500 Pyle

Printed  
Circuit Board

EMI Filter  
Transient

Fiber Optics

High Speed  
Contacts

Options  
Others

**Amphenol® Quadrax Contacts for Printed Circuit Board Attachment**

Available for MIL-DTL-38999 Series III Circular connectors with straight PC tail termination and with compliant pin termination. These provide the ideal solution for bringing high speed data transmission to the board.



Compliant Pin Quadrax and PC Tail Quadrax Contacts



MIL-DTL-38999, SERIES III CONNECTOR WITH PC TAIL CONTACTS. This arrangement has 33 size 22D and 2 Quadrax PC tail contacts.

MIL-DTL-38999, SERIES III CONNECTOR WITH PC TAIL CONTACTS. This arrangement has 8 Quadrax PC tail contacts.



**Amphenol® Quadrax Contacts for Rectangular Board Level Connectors**

Incorporate the same size 8 Quadrax PCB contacts as used in circular 38999 connectors.

- Size 8 Quadrax Compliant contacts with hole diameters:  
 .025 ± .002 PTH Quadrax contact  
 .040 ± .003 PTH shell grounding  
 Accommodates backplane .125 inch min. thickness
- Consult Amphenol Aerospace for availability of additional connector configurations

**4 POSITION BOARD LEVEL CONNECTOR WITH QUADRAX**



Compliant Pin Quadrax Board Level Connector

**8 POSITION BOARD LEVEL CONNECTOR WITH QUADRAX**



# Quadrax Transition Adapters and Differential Twinax Transition Adapters

## General Description

**Amphenol® Transition Adapters** - Are used to facilitate launching of controlled impedance signals to printed circuit boards. Amphenol provides transition adapters in both contact types:

- Quadrax transition adapters, 90° or straight receptacles threaded or cable to board style
- Differential twinax transition adapters, 90° or straight receptacles, threaded or cable to board style



90° Quadrax Receptacle and Plug Transition Adapter

### Suggested Numbering for Transition Adapters with Quadrax Contacts

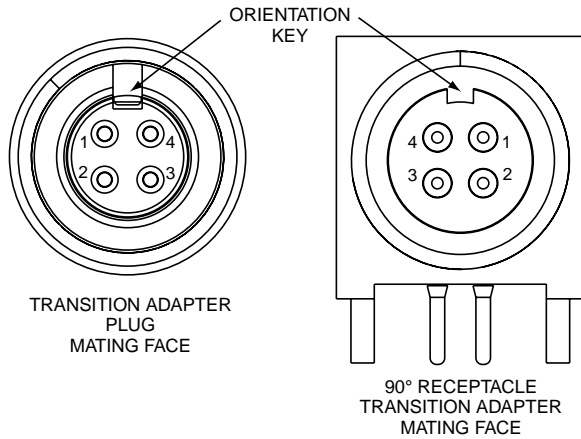

90° Differential Twinax Receptacle and Plug Transition Adapter

### TRANSITION ADAPTER DATA

Finish of mating contact parts: Contacts are supplied gold plated per ASTM B488 Type II, Code C, .000050 min. thick over nickel plate per AMS-QQ-N-290, Class 2, .000030/.000150 thick.

QUADRA  
X  
TRANSITION  
ADAPTER  
PLUG

QUADRA  
X  
TRANSITION  
ADAPTER  
90 DEGREE  
RECEPTACLE

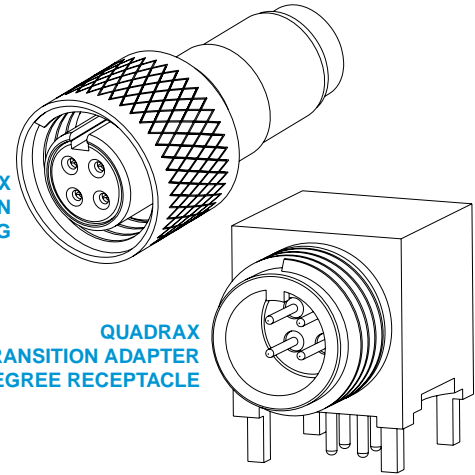

| ELECTRICAL PROTOCOLS FOR QUADRA X TRANSITION ADAPTERS |                          |                  |                             |
|---|--------------------------|------------------|-----------------------------|
| Part Number   |                          | Impedance (Ohms) | Electrical Protocol††       |
| Plug  | Receptacle               |                  |                             |
| 21-33836-31   |                          | 100              | Ethernet, gigabit Ether     |
| 21-33836-41   |                          |                  | Ethernet, gigabit Ether     |
| 21-33836-51   |                          |                  | Ethernet, gigabit Ether     |
| 21-33836-61   |                          |                  | Ethernet, gigabit Ether     |
|   | 21-33837-81 (90 degree)  |                  |                             |
|   | 21-33837-91 (90 degree)  |                  |                             |
|   | 21-33837-41 (90 degree)  |                  |                             |
|   | 21-33837-51 (straight)   |                  | Ethernet, gigabit Ether     |
|   | 21-33837-61 (90 degree)  |                  |                             |
|   | 21-33837-141 (90 degree) |                  |                             |
| 21-33837-101  |                          | 150              |                             |
| 21-33836-21   |                          |                  | 1000 Base CX, Fibre channel |
|   | 21-33837-21 (90 degree)  |                  | 1000 Base CX, Fibre channel |
|   | 21-33837-211 (jam nut)   |                  |                             |
|   | 21-33837-31 (straight)   |                  |                             |
|   | 21-33837-71 (90 degree)  |                  |                             |
| 21-33837-111  |                          |                  |                             |

| ELECTRICAL PROTOCOLS FOR DIFFERENTIAL TWINAX TRANSITION ADAPTERS |                           |                  |                       |
|--|---------------------------|------------------|-----------------------|
| Part Number  |                           | Impedance (Ohms) | Electrical Protocol†† |
| Plug   | Receptacle                |                  |                       |
| 21-33832-81  |                           | 100              |                       |
| 21-33832-21  |                           |                  | Ethernet              |
|  | 21-33833-21 (90 degree)   |                  |                       |
|  | 21-33833-31 (90 degree)   |                  | Ethernet              |
|  | 21-33833-151 (90 degree)  |                  |                       |
| 21-33832-111†  |                           |                  |                       |
|  | 21-33833-161† (90 degree) |                  |                       |
|  | 21-33833-171† (90 degree) |                  |                       |
|  | 21-33833-91 (90 degree)   |                  |                       |
|  | 21-33833-51 (90 degree)   |                  |                       |
|  | 21-33833-141 (90 degree)  |                  |                       |
| 21-33832-91  |                           | 150              |                       |
|  | 21-33833-111 (90 degree)  |                  |                       |
|  | 21-33833-181† (90 degree) |                  |                       |
|  | 21-33833-101 (90 degree)  |                  |                       |

† Consult Amphenol Aerospace for current release of this adapter.

†† Test reports available for indicated protocols; consult Amphenol Aerospace.

III  
II  
I  
SJT  
38999

Matrix 2  
26482

Matrix Pyle  
83723 III

Release Matrix  
Crimp Rear  
5015

26500 Pyle

Printed  
Circuit Board

EMI Filter  
Transient

Fiber Optics

High Speed  
Contacts

Options  
Others

### Application Data

#### 100 OHM QUADRIX TRANSITION ADAPTERS FOR LAUNCHING CONTROLLED IMPEDANCE SIGNALS TO PC BOARDS

| Quadrax Type Adapter/<br>Cable or PCB Tail Length                                    | Illustration of Adapter | Part Number<br>(Termination Instruction Sheet)** |                              | Impedance<br>(Ohms)         | Mating<br>Thread<br>Size | Crimping Tools  |  |
|--|-------------------------|--|------------------------------|-----------------------------|--------------------------|---|--|
|  |                         | Plug   | Receptacle                   |                             |                          | Inner Contact   | Outer Contact  |
| Quadrax Plug Adapter/<br>Tensolite NF24Q100  |                         | 21-33836-31<br>(L-2119-U)                        |                              | 100                         | .375                     | M22520/2-01<br>with Positioner<br>M22520/2-37<br>or with<br>Daniels<br>Positioner<br>K709 | M22520/5-01<br>with Die Set<br>M22520/5-45<br>(Location A) |
| Quadrax Plug Adapter/<br>Tensolite NF22Q100,<br>NF22Q100-01, Thermax 956-5           |                         | 21-33836-41<br>(L-2119-W)†                       |                              |                             |                          |   |  |
| Quadrax Plug Adapter/<br>Draka Fileca F-4703-3,<br>F-4704-4                          |                         | 21-33836-51<br>(L-2119-Y)                        |                              |                             |                          |   |  |
| Quadrax Plug Adapter/<br>NF26Q100  |                         | 21-33836-61<br>(L-2119-AM)†                      |                              |                             |                          |   |  |
| Quadrax Plug Adapter/<br>Hexnut with Lock Wire Holes<br>Tensolite NF24Q100           |                         | 21-33836-81                                      |                              |                             |                          |   |  |
| Quadrax Receptacle Straight<br>Adapter in-line jam nut<br>(threaded)/ GSC-10-8273900 |                         |  | 21-33837-81<br>(L-2119-AR)†  |                             |                          |   |  |
| Quadrax Receptacle Straight<br>Adapter in-line (threaded)/<br>NF24Q100               |                         |  | 21-33837-91<br>(L-2119-BL)   |                             |                          |   |  |
| PCB Quadrax Receptacle 90<br>Degree Adapter/<br>Tail Length .110                     |                         |  | 21-33837-41                  |                             |                          |   |  |
| PCB Quadrax Receptacle 90<br>Degree Adapter/<br>Tail Length .200                     |                         |  | 21-33837-201                 |                             |                          |   |  |
| PCB Quadrax Receptacle<br>Straight Adapter/<br>Tail Length .110                      |                         |  | 21-33837-51                  |                             |                          |   |  |
| PCB Quadrax Receptacle<br>Straight Adapter/<br>Special Tail Length (.200)            |                         |  | 21-33837-61                  |                             |                          |   |  |
| Quadrax Receptacle 90<br>degree Adapter with cable to<br>board/<br>NF24Q100          |                         |  | 21-33837-141<br>(L-2119-BB)† |                             |                          |   |  |
| Quadrax Receptacle 90<br>degree Adapter with cable to<br>board/<br>ABS1503KD24       |                         |  | 21-33837-231                 |                             |                          |   |  |
| Quadrax Receptacle Straight<br>Adapter<br>with cable to board/<br>NF24Q100           |                         |  |                              | 21-33837-101<br>(L-2119-AN) |                          |   |  |

CONTACT ORDERING: Example number given in chart 21-33837-81 should be ordered as 21-033837-081; example number 21-33837-101 should be ordered as 21-033837-101. Adding Zeros is necessary for Amphenol ordering process on all contact numbers. Daniels crimping tools are available from Daniels Mfg. Corp. 6103 Anno Ave., Orlando, FL 32809

\*\*Termination instructions are packaged with each contact and can be found on-line at: [www.amphenol-aerospace.com/serviceinstructions.asp](http://www.amphenol-aerospace.com/serviceinstructions.asp)  
† Consult Amphenol Aerospace for current release of this adapter and instruction sheet if applicable.  
See electrical protocols for transition adapters on page 383.

38999  
SJT I II III

26482  
Matrix 2

83723 III  
Matrix Pyle

5015  
Crimp Rear  
Release Matrix

26500 Pyle

Printed  
Circuit Board

EMI Filter  
Transient

Fiber Optics

High Speed  
Contacts

Options  
Others

# Quadrax Transition Adapters

For Attachment to PC Boards



## Application Data

| 150 OHM QUADRAX TRANSITION ADAPTERS<br>FOR LAUNCHING CONTROLLED IMPEDANCE SIGNALS TO PC BOARDS                         |                         |  |                                 |                     |                          |   |  |
|--|-------------------------|--|---------------------------------|---------------------|--------------------------|---|--|
| Quadrax Type Adapter/<br>Cable or PCB Tail Length  | Illustration of Adapter | Part Number<br>(Termination Instruction Sheet)** |                                 | Impedance<br>(Ohms) | Mating<br>Thread<br>Size | Crimping Tools                                |  |
|  |                         | Plug   | Receptacle                      |                     |                          | Inner Contact                                 | Outer Contact  |
| Quadrax Plug Adapter/<br>Tensolite 26473/02006X-4(LD),<br>Gore RCN8328   |                         | 21-33836-21<br>(L-2119-S)                        |                                 | 150                 | .375                     | M22520/2-01<br>with Positioner<br>M22520/2-34 | NA   |
| PCB Quadrax Receptacle 90<br>Degree Adapter/<br>Tail Length .110   |                         |  | 21-33837-21                     |                     |                          | NA  |  |
| PCB Quadrax Receptacle<br>Straight Adapter/<br>Tail Length .110  |                         |  | 21-33837-31                     |                     |                          | NA  |  |
| Quadrax Receptacle Straight<br>Adapter in-line Jam Nut<br>(threaded) Tensolite<br>26473/02006X-4 (LD), Gore<br>RCN8328 |                         |  | 21-33837-211<br>(L-2119-BY)     | 150                 |                          |   |  |
| Quadrax Receptacle 90<br>degree Adapter with cable to<br>board/<br>Tensolite 26473/02006X-4                            |                         |  | 21-33837-71<br>(L-2119-A)†      |                     |                          | M22520/2-01<br>with Positioner<br>M22520/2-34 | M22520/5-01<br>with Die Set<br>M22520/5-45<br>(Location A) |
| Quadrax Receptacle Straight<br>Adapter<br>with cable to board/<br>Tensolite 26473/02006X-4 (LD)                        |                         |  | 21-33837-<br>111<br>(L-2119-AP) |                     |                          |   |  |

CONTACT ORDERING: Example number given in chart 21-33837-81 should be ordered as 21-033837-081; example number 21-33837-101 should be ordered as 21-033837-101. Adding Zeros is necessary for Amphenol ordering process on all contact numbers. Daniels crimping tools are available from Daniels Mfg. Corp. 6103 Anno Ave., Orlando, FL 32809

\*\*Termination instructions are packaged with each contact and can be found on-line at: [www.amphenol-aerospace.com/serviceinstructions.asp](http://www.amphenol-aerospace.com/serviceinstructions.asp)

† Consult Amphenol Aerospace for current release of this adapter and instruction sheet if applicable.

See electrical protocols for transition adapters on page 383.

38999  
III  
II  
I  
SJT

26482  
Matrix 2

83723 III  
Matrix  
Pyle

5015  
Crimp Rear  
Release Matrix

26500 Pyle

Printed  
Circuit Board

EMI Filter  
Transient

Fiber Optics

High Speed  
Contacts

Options  
Others



| 100 OHM DIFFERENTIAL TWINAX TRANSITION ADAPTERS FOR LAUNCHING CONTROLLED IMPEDANCE SIGNALS TO PC BOARDS |  |   |  |                             |                           |                          |  |  |                            |
|---|--|---|--|-----------------------------|---------------------------|--------------------------|--|--|----------------------------|
|   | Differential Twinax Type Adapter/<br>Cable or PCB Tail Length                  | Illustration of Adapter   | Part Number<br>(Termination Instruction Sheet)** |                             | Impedance<br>(Ohms)       | Mating<br>Thread<br>Size | Crimping Tools                                   |  |                            |
|   |  |   | Plug   | Receptacle                  |                           |                          | Inner Contact                                    | Outer Contact  |                            |
| 38999<br>SJT  | Differential Twinax Plug Adapter/<br>M17/176-00002 (77 ohms)                   |   | 21-33832-81<br>(L-2119-A)                        |                             | 100                       | .3125                    | M22520/2-01<br>with<br>Positioner<br>M22520/2-34 | M22520/5-01<br>with Die Set<br>M22520/5-05<br>(Location B) |                            |
| 26482<br>Matrix 2   | Differential Twinax Plug Adapter/<br>Tensolite 24463/9P025X-2(LD)<br>10-646060 |   | 21-33832-21<br>(L-2119-P)                        |                             |                           |                          |  |  |                            |
| 83723 III<br>Pyle   | PCB Differential Twinax<br>Receptacle 90 Degree Adapter/<br>Tail Length .110   |   |  | 21-33833-21                 | 100                       | .3125                    | N/A  | N/A  |                            |
|   | 83723 III<br>Matrix  | PCB Differential Twinax<br>Receptacle Straight Adapter/<br>Tail Length .110   |  | 21-33833-31                 |                           |                          |  |  |                            |
| 5015<br>Crimp Rear<br>Release Matrix  | PCB Differential Twinax<br>Receptacle Straight Adapter/<br>Tail Length .165    |   |  | 21-33833-151                | 100                       | .375                     | N/A  | N/A  |                            |
|   | 26500 Pyle   | Differential Twinax Plug<br>Adapter/Tensolite<br>CAN22TDT120 (120 Ohm)  |  | 21-33832-111†               |                           |                          |  |  |                            |
| 5015<br>Crimp Rear<br>Release Matrix  |  | PCB Differential Twinax<br>Receptacle 90 degree Adapter/<br>Tail Length .283  |  |                             | 21-33833-161†             |                          |  |  |                            |
| Printed<br>Circuit Board  | PCB Differential Twinax<br>Receptacle Straight Adapter/<br>Tail Length .283    |   |  | 21-33833-171†               | 100                       | N/A                      | M22520/2-01<br>with<br>Positioner<br>M22520/2-34 | M22520/5-01<br>with Die Set<br>M22520/5-45<br>(Location A) |                            |
|   | EMI Filter<br>Transient  | Differential Twinax Receptacle<br>90 degree Adapter (low profile)<br>with cable to board/ Tensolite<br>24463/9P026X-2 |  |                             |                           |                          |  |  | 21-33833-91<br>(L-2119-AF) |
| 26500 Pyle  |  | Differential Twinax Receptacle<br>90 degree Adapter with cable to<br>board/<br>Tensolite 24463/9P025X-2               |  |                             | 21-33833-51<br>(L-2119-V) |                          |  |  |                            |
| Differential Twinax Receptacle<br>90 degree Adapter with cable to<br>board/Tensolite<br>24463/9P025X-2  |  |   |  | 21-33833-141<br>(L-2119-BU) |                           |                          |  |  |                            |

| 150 OHM DIFFERENTIAL TWINAX TRANSITION ADAPTERS FOR LAUNCHING CONTROLLED IMPEDANCE SIGNALS TO PC BOARDS |   |   |  |                              |                     |                          |  |  |     |
|---|---|---|--|------------------------------|---------------------|--------------------------|--|--|-----|
|   | Differential Twinax Type Adapter/<br>Cable or PCB Tail Length   | Illustration of Adapter   | Part Number<br>(Termination Instruction Sheet)**                             |                              | Impedance<br>(Ohms) | Mating<br>Thread<br>Size | Crimping Tools                                   |  |     |
|   |   |   | Plug   | Receptacle                   |                     |                          | Inner Contact                                    | Outer Contact  |     |
| High Speed<br>Contacts  | Differential Twinax Plug<br>Adapter/<br>Tensolite 26483/03071X-2  |   | 21-33832-91<br>(L-2119-BR)   |                              | 150                 | .375                     | M22520/2-01<br>with<br>Positioner<br>M22520/2-34 | M22520/5-01<br>with Die Set<br>M22520/5-45<br>(Location A) |     |
|   | 26500 Pyle  |   | PCB Differential Twinax<br>Receptacle 90 Degree Adapter/<br>Tail Length .110 |                              |                     |                          | 21-33833-111                                     | N/A  | N/A |
|   | Options<br>Others   | PCB Differential Twinax<br>Receptacle Straight Adapter/<br>Tail Length .110 |  |                              | 21-33833-181†       | N/A                      | N/A  |  |     |
| Options<br>Others   | Differential Twinax Receptacle<br>90 degree Adapter with cable to<br>board/<br>Tensolite 26483/03071X-2 |   |  | 21-33833-101<br>(L-2119-BM)† | 150                 | N/A                      | M22520/2-01<br>with<br>Positioner<br>M22520/2-34 | M22520/5-01<br>with Die Set<br>M22520/5-45<br>(Location A) |     |

CONTACT ORDERING: Example number given in chart 21-33832-21 should be ordered as 21-033832-021; example number 21-338373-141 should be ordered as 21-033833-141. Adding Zeros is necessary for Amphenol ordering process on all contact numbers.

\*\*Termination instructions are packaged with each contact and can be found on-line at: [www.amphenol-aerospace.com/serviceinstructions.asp](http://www.amphenol-aerospace.com/serviceinstructions.asp)

† Consult Amphenol Aerospace for current release of this adapter and instruction sheet if applicable. See electrical protocols for transition adapters on page 383.



# Insert Arrangements - MIL-DTL-38999, Series III Incorporating Quadrax & Differential Twinax Contacts



This illustrated listing represents the most readily available patterns incorporating quadrax and differential twinax contacts within D38999, Series III connectors. If you require other arrangements than what are shown here, consult Amphenol for further availability. In most cases, unless otherwise stated, size 8 cavities can be filled with quadrax or differential twinax contacts. Arrangements can be mixed with any size 8 coax, and/or concentric twinax or triax contacts.

## Front face of pin inserts illustrated

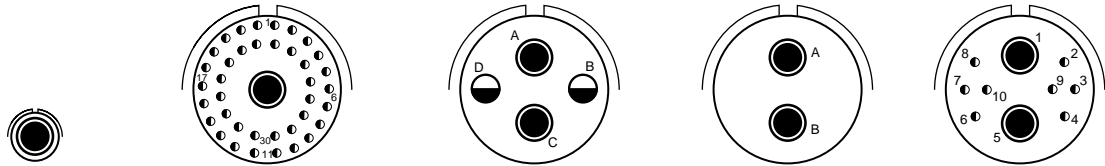

| Insert Arrangement | 9-5      |  | 17-2 |          | 17-22 |   | 17-52                      |     | 17-60 |  |
|--------------------|----------|--|------|----------|-------|---|----------------------------|-----|-------|--|
| Number of Contacts | 1        |  | 38   | 1        | 2     | 2 | 2                          | 8   | 2     |  |
| Contact Size       | 8        |  | 22D  | 8 Twinax | 12    | 8 | 8                          | 22D | 8     |  |
|                    | Grounded |  |      |          |       |   | Meets Boeing Specification |     |       |  |

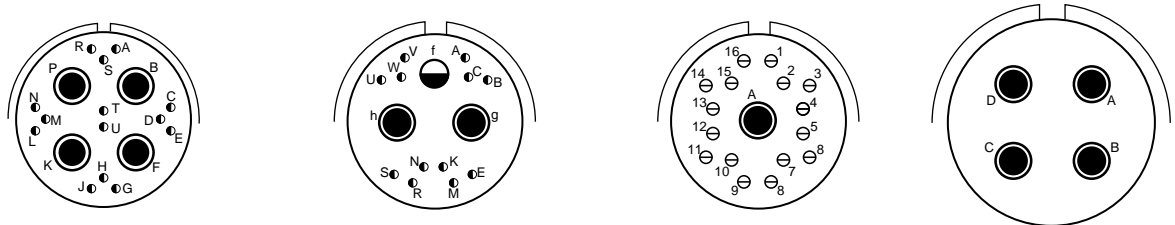

| Insert Arrangement | 19-18 |   | 19-31 |    |   | 19-AD |   | 21-75 |  |
|--------------------|-------|---|-------|----|---|-------|---|-------|--|
| Number of Contacts | 14    | 4 | 12    | 1  | 2 | 16    | 1 | 4     |  |
| Contact Size       | 22D   | 8 | 22D   | 12 | 8 | 20    | 8 | 8     |  |

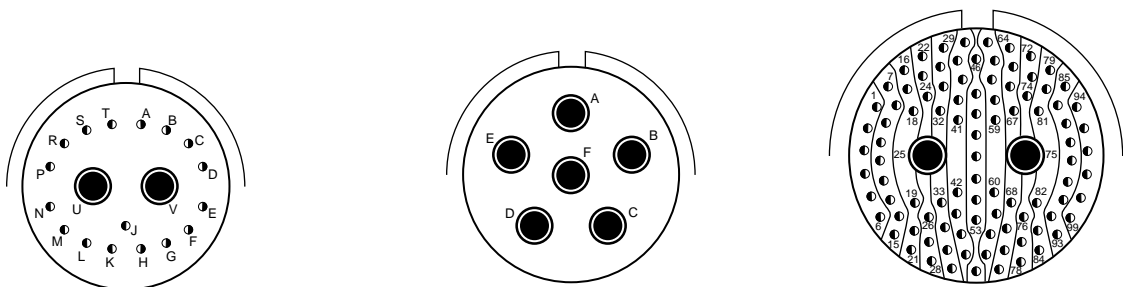

| Insert Arrangement | 21-79 |   | 23-6 |  | 25-7 |   |
|--------------------|-------|---|------|--|------|---|
| Number of Contacts | 17    | 2 | 6    |  | 97   | 2 |
| Contact Size       | 22D   | 8 | 8    |  | 22D  | 8 |

### CONTACT LEGEND



- III 38999 I SJT
- Matrix 2 26482
- Matrix Pyle 83723 III
- Crimp Rear Release Matrix 5015
- Pyle 26500
- Printed Circuit Board
- EMI Filter Transient
- Fiber Optics
- High Speed Contacts
- Options Others

- 38999  
SJT I II III
- 26482  
Matrix 2
- 83723 III  
Matrix Pyle
- 5015  
Crimp Rear Release Matrix
- 26500 Pyle
- Printed  
Circuit Board
- EMI Filter  
Transient
- Fiber Optics
- High Speed  
Contacts
- Options  
Others

Front face of pin inserts illustrated

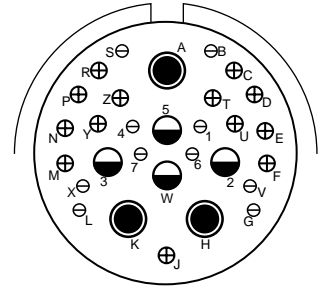
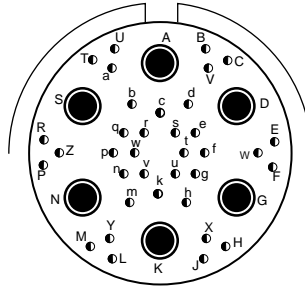
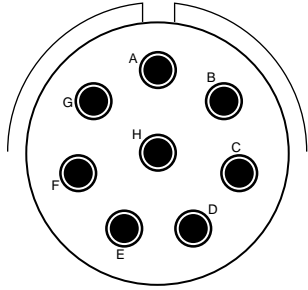

| Insert Arrangement | 25-8 |  |  | 25-17 |   | 25-20 |    |   |    |
|--------------------|------|--|--|-------|---|-------|----|---|----|
| Number of Contacts | 8    |  |  | 36    | 6 | 10    | 13 | 3 | 4  |
| Contact Size       | 8    |  |  | 22D   | 8 | 20    | 16 | 8 | 12 |

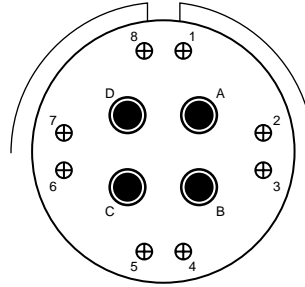
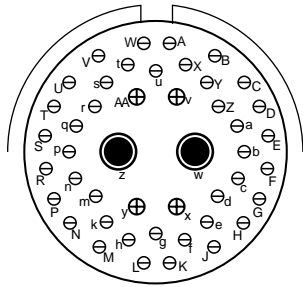

| Insert Arrangement | 25-46             |    |   | 25-62 |   |
|--------------------|-------------------|----|---|-------|---|
| Number of Contacts | 40                | 4  | 2 | 8     | 4 |
| Contact Size       | 20                | 16 | 8 | 16    | 8 |
|                    | Ground plane only |    |   |       |   |

**CONTACT LEGEND**

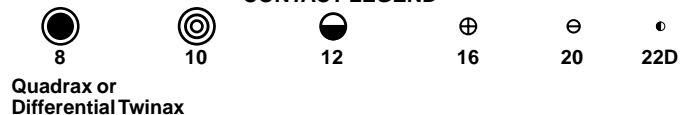

# How to Order 38999, Series III Circular With Quadrax 100 Ohm Contacts

Amphenol Tri-Start, 38999 Series III\* Connectors can be ordered with the following popularly used Quadrax contacts:  
 100 ohm quadrax 21-033385-051 socket contacts  
 100 ohm quadrax 21-033384-051 pin contacts  
 Use the following coded number ordering procedure :

|                |            |               |                                 |              |                           |
|----------------|------------|---------------|---------------------------------|--------------|---------------------------|
| 1.             | 2.         | 3.            | 4.                              | 5.           | 6.                        |
| Connector Type | Shell Type | Service Class | Shell Size – Insert Arrangement | Contact Type | Alternate Keying Position |
| <b>TVP</b>     | <b>00</b>  | <b>RQW</b>    | <b>21-75</b>                    | <b>P</b>     | <b>B</b>                  |

For ordering of connectors with any other quadrax contacts or differential twinax contacts, please consult Amphenol Aerospace for part numbers.

## Step 1. Select a Connector Type

|             |   |
|-------------|---|
| <b>TV</b>   | Tri-Start Series Connector with metal shells        |
| <b>TVP</b>  | Back panel mounted receptacle with metal shells     |
| <b>CTV</b>  | Tri-Start Series Connector with composite shells    |
| <b>CTVP</b> | Back panel mounted receptacle with composite shells |

## Step 2. Select a Shell Style

|           |   |
|-----------|---|
| <b>00</b> | Wall mount receptacle   |
| <b>02</b> | Box mount receptacle available only with the PCB tails and epoxy backfilled (non-removable) |
| <b>06</b> | Straight plug   |
| <b>07</b> | Jam nut receptacle  |

## Step 3. Select a Service Class with Quadrax

|             |   |
|-------------|---|
| <b>RQF</b>  | Electroless nickel plated aluminum                  |
| <b>RGQF</b> | Electroless nickel plated ground plane aluminum     |
| <b>RQW</b>  | Olive drab cadmium plate                            |
| <b>RGQW</b> | Olive drab cadmium plated ground plane aluminum     |
| <b>RQB</b>  | NiAlBronze  |
| <b>RGQB</b> | NiAlBronze ground plane                             |
| <b>RQK</b>  | Corrosion resistance stainless steel                |
| <b>RGQK</b> | Stainless steel ground plane                        |
| <b>QDT</b>  | Durmalon plated, Nickel-PTFE alternative to cadmium |
| <b>GQDT</b> | Groundplane Durmalon                                |

## Step 4. Select a Shell Size and Insert Arrangement

See insert arrangements available with quadrax contacts on preceding pages. Shell Size and Insert Arrangements are together in one chart. First number represents Shell Size, second number is the Insert Arrangement

## Step 5. Select Contact Type

|          |                 |
|----------|-----------------|
| <b>P</b> | Pin contacts    |
| <b>S</b> | Socket contacts |

## Step 6. Select an Alternate Keying Position

Locksmith keying—rotation of minor keys. See Series III Alternate Positions below “N” not required for normal position

### Tri-Start Alternate Positions

A plug with a given rotation letter will mate with a receptacle with the same rotation letter. The angles for a given connector are the same whether it contains pins or sockets. Inserts are not rotated in conjunction with the master key/keyway.

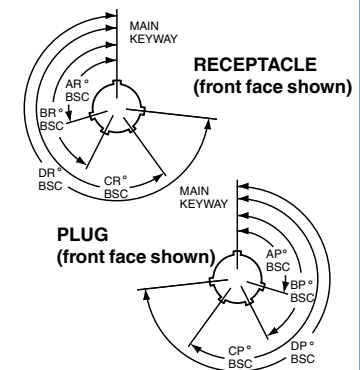

| Shell Size      | Key & Keyway Arrangement Identification Letter | AR° or AP° BSC | BR° or BP° BSC | CR° or CP° BSC | DR° or DP° BSC |
|-----------------|--|----------------|----------------|----------------|----------------|
| 9               | N  | 105            | 140            | 215            | 265            |
|                 | A  | 102            | 132            | 248            | 320            |
|                 | B  | 80             | 118            | 230            | 312            |
|                 | C  | 35             | 140            | 205            | 275            |
|                 | D  | 64             | 155            | 234            | 304            |
| 11, 13, and 15  | N  | 95             | 141            | 208            | 236            |
|                 | A  | 113            | 156            | 182            | 292            |
|                 | B  | 90             | 145            | 195            | 252            |
|                 | C  | 53             | 156            | 220            | 255            |
|                 | D  | 119            | 146            | 176            | 298            |
| 17 and 19       | N  | 80             | 142            | 196            | 293            |
|                 | A  | 135            | 170            | 200            | 310            |
|                 | B  | 49             | 169            | 200            | 244            |
|                 | C  | 66             | 140            | 200            | 257            |
|                 | D  | 62             | 145            | 180            | 280            |
| 21, 23, and 25  | N  | 80             | 142            | 196            | 293            |
|                 | A  | 135            | 170            | 200            | 310            |
|                 | B  | 49             | 169            | 200            | 244            |
|                 | C  | 66             | 140            | 200            | 257            |
|                 | D  | 62             | 145            | 180            | 280            |
| 25L, 33, and 37 | N  | 80             | 142            | 188            | 293            |
|                 | A  | 135            | 170            | 188            | 310            |
|                 | B  | 49             | 169            | 188            | 244            |
|                 | C  | 66             | 140            | 188            | 257            |
|                 | D  | 62             | 145            | 188            | 280            |
|                 | E  | 79             | 153            | 188            | 272            |

\* The incorporation of quadrax or differential twinax contacts requires a modified connector to accommodate keyed contacts.

For more information on Tri-Start, MIL-DTL-38999 Series III connectors see the section in this catalog.

III  
II  
I  
SJT  
38999

Matrix 2  
26482

Matrix Pyle  
83723 III

Release Matrix  
5015  
Crimp Rear

26500 Pyle

Circuit Board  
Printed

Transient  
EMI Filter

Fiber Optics

High Speed  
Contacts

Options  
Others

38999  
SJT I II III

26482  
Matrix 2

83723 III  
Matrix Pyle

5015  
Crimp Rear  
Release Matrix

26500 Pyle

Printed  
Circuit Board

EMI Filter  
Transient

Fiber Optics

High Speed  
Contacts

Options  
Others

**Amphenol® Coaxial Contacts** - Offer several advantages for reliable interconnection and continued performance:

- Large crimping area assures low contact resistance and high tensile strength
- Back insulator positively captivates inner contact against axial loads
- Front insulator provides closed entry for socket inner contact
- Recessed inner contact is protected
- Outer contact has rugged wall section for durability

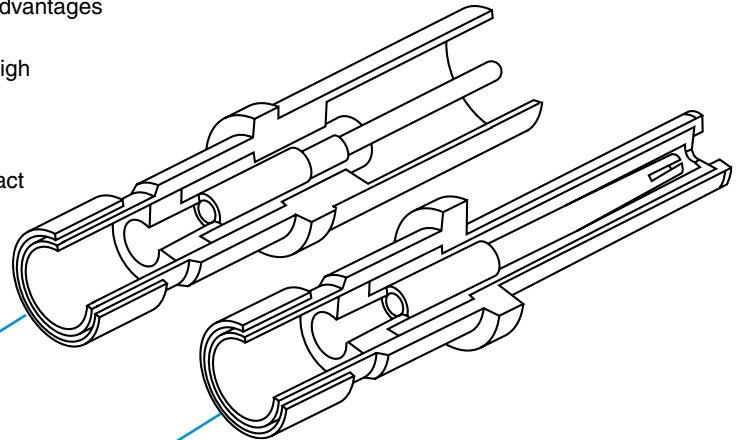

TYPICAL SUBMINIATURE COAX SOCKET CONTACT has socket outer contact with a pin inner contact

TYPICAL SUBMINIATURE COAX PIN CONTACT has pin outer contact with a socket inner contact



MIL-DTL-38999 LJT-R, JT-R, TV-R, SJT-R MS Type, Coax Size 12 Socket Assembled Contact



MIL-DTL-38999 LJT-R, JT-R, TV-R, SJT-R MS Type, Coax Size 16 Pin Unassembled Contact



MIL-DTL-38999 LJT-R, JT-R, TV-R, SJT-R MS Type, Coax Size 8 Pin Assembled Contact



MIL-DTL-38999 LJT-R, JT-R, TV-R, SJT-R MS Type, Coax Size 8 Socket Unassembled Contact

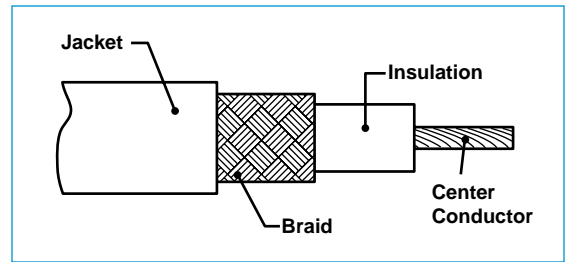

Cable Illustration - Coax Contact

### Coax Contacts are gold plated, crimp termination

Finish of mating contacts parts: supplied with 0.000050 min. gold over nickel on mating parts. Other finishes are available; consult Amphenol for further information.

#### Coax Size 12 & 16 Contact Performance:

- Typical VSWR: 1.5:1 maximum up to 700 MHz and 500 MHz respectively, for properly cabled size 12 and 16 coaxial contacts in the M38999 Series I, II and III
- Insulation Resistance: 5,000 megohms minimum @ 25°C
- Dielectric Withstanding Voltage:  
Size 12: 1,000 VAC Rms @ sea level, 250 VAC Rms @ 50,000 ft.  
Size 16: 800 VAC Rms @ sea level, 250 VAC Rms @ 50,000 ft.
- Contact Resistance: See MIL-C-39029/27, /28, /75, /76, /77, /78

#### Coax Size 8 Contact Performance:

- Typical VSWR when terminated to specified 50 ohm cable: 1.5:1 maximum up to 3 GHz (excluding 21-33101/2-27)
- Insulation Resistance: 5,000 megohms minimum @ 25°C
- Dielectric Withstanding Voltage:  
1,300 VAC Rms @ sea level, 250 VAC Rms @ 50,000 ft.
- Contact Resistance: See MIL-C-39029/59, /60

### JT-R Series, MIL-DTL-38999 Series II, SAE AS39029 (27, 28, 76, 78)

| COAX CONTACTS FOR USE IN JT-R CONNECTORS   |   |   |  |  |   |  |  |
|--|---|---|--|--|---|--|--|
| Cable  | Contact Part Number<br><small>(Termination Instruction Sheet)**</small> |   | Contact Size                               | Crimping Tools   |   | Installation Tools                         |  |
|  | Pin   | Socket  |  | Inner Contact  | Crimp Ferrule                                 | Insertion                                  | Removal  |
| RG-178B/U, RG-196A/U   | 21-33122-564<br>(M39029/76-425)<br><small>(L-2035-AG)</small>           | 21-33121-564<br>(M39029/78-433)<br><small>(L-2035-AH)</small> | 16   | M22520/2-01<br>with Positioner<br>M22520/2-35<br>or with<br>Daniels Positioner<br>K532 | M22520/4-01<br>with Positioner<br>M22520/4-02 | M81969/8-07<br>or<br>M81969/14-03          | M81969/8-08<br>or<br>M81969/14-03  |
| Haveg<br>30-00761, 30-02024,<br>30-02033<br>Tensolite<br>24713/A955KK1, 26723/<br>A955KK1  | 21-33122-562†<br><small>(L-2035-AN)</small>                             | 21-33121-562†<br><small>(L-2035-AP)</small>                   |  |  |   | Amphenol<br>11-8674-16<br>or<br>11-8794-16 | Amphenol<br>11-8675-16<br>or<br>11-8795-16   |
| Haveg 61-02051   | 21-33122-561†<br><small>(L-2035-AK)</small>                             | 21-33121-561†<br><small>(L-2035-AL)</small>                   |  |  |   | MS27495A16<br>or<br>MS27534-16             | MS27495R16<br>or<br>MS27534-16   |
| RG-174A/U, RG-188A/U,<br>RG-161/U,<br>RG-187A/U, RG-316/U,<br>RG-179B/U,<br>Haveg 8100207, Times<br>(HS-179)<br>AA3248, Teledyne 11299 | 21-33122-563<br>(M39029/76-424)<br><small>(L-2035-AD)</small>           | 21-33121-563<br>(M39029/78-432)<br><small>(L-2035-AE)</small> |  |  |   | 12   | M22520/2-01<br>with Positioner<br>M22520/2-34<br>or with<br>Daniels Positioner<br>K323 |
| RG-180B/U, RG-195A/U,<br>Raychem 9528A1318   | 21-33122-541<br>(M39029/28-409)<br><small>(L-2035-C)</small>            | 21-33121-541<br>(M39029/27-402)<br><small>(L-2035-E)</small>  | Amphenol<br>11-8674-12<br>or<br>11-8794-12 | Amphenol<br>11-8675-12<br>or<br>11-8795-12   |   |  |  |
| Raychem 5022E5111  | 21-33122-543†<br><small>(L-2035-M)</small>                              | 21-33121-543†<br><small>(L-2035-N)</small>                    | MS27495A12<br>or<br>MS27534-12             | MS27495R12<br>or<br>MS27534-12   |   |  |  |
| Raychem 9530A5314  | 21-33122-544<br><small>(L-2035-R)</small>                               | 21-33121-544<br><small>(L-2035-S)</small>                     | MS27534-12                                 | MS27534-12   |   |  |  |
| Raychem 9527A1318  | 21-33122-545<br><small>(L-2035-U)</small>                               | 21-33121-545<br><small>(L-2035-V)</small>                     |  |  |   |  |  |
| Gore GWN1159A  | 21-33122-547†<br><small>(L-2035-X)</small>                              | 21-33121-547†<br><small>(L-2035-Y)</small>                    |  |  |   |  |  |

### MIL-DTL-38999 CONTACT DATA

All contacts mate with other contacts in this series which have the same inner and outer contact diameters.

CONTACT ORDERING: Example number given in chart 21-33122-564 should be ordered as 21-033122-564.

Adding Zeros is necessary for Amphenol ordering process on all contact numbers

† Consult Amphenol Aerospace for current release of this contact or instruction sheet if applicable.

NOTE: SAE AS39029 supersedes MIL-C-39029

\*\*Termination instructions are packaged with each contact and can be found on-line at:

[www.amphenol-aerospace.com/serviceinstructions.asp](http://www.amphenol-aerospace.com/serviceinstructions.asp)

|   |   |
|---|---|
| JT Example:                             | Socket 21-33121-564 on RG-196A/U cable will mate with pin 21-33122-563 on RG-188A/U cable which is used in both this and the LJ-T-R series. |
| LJT, TV, SJT,<br>Amphe-Lite<br>Example: | Socket 21-33123-564 on RG-196A/U cable will mate with pin 21-33122-563 on RG-188A/U cable which is used in both this and the JT-R series.   |

Finish of mating contact parts: Contact part numbers shown in the chart above are supplied with 0.000050 min. gold (Knoop hardness 130-200) over nickel on mating parts. Other finishes are available; consult Amphenol.

Daniels crimping tools are available from:

Daniels Mfg. Corp. 6103 Anno Ave., Orlando FL 32809

38999  
III  
II  
I  
SJT

26482  
Matrix 2

83723 III  
Matrix  
Pyle

5015  
Crimp Rear  
Release Matrix

26500 Pyle

Printed  
Circuit Board

EMI Filter  
Transient

Fiber Optics

High Speed  
Contacts

Options  
Others

### LJT-R, MIL-DTL-38999 Series I; TV-R, MIL-DTL-38999 Series III; Amphe-Lite and SJT-R Series, SAE AS39029 (28, 59, 60, 75, 76, 77)

#### COAX CONTACTS FOR USE IN LJTR, TVR, AMPHE-LITE AND SJTR CONNECTORS

| Cable   | Contact Part Number                                   |   | Contact Size | Crimping Tools   |  | Installation Tools                         |  |   |                  |                     |
|---|---|---|--------------|--|--|--|--|---|------------------|---------------------|
|   | Pin   | Socket  |              | Inner Contact  | Crimp Ferrule  | Insertion                                  | Removal  |   |                  |                     |
| RG-178B/U, RG-196A/U  | 21-33122-564<br>(M39029/76-425)<br><i>(L-2035-AG)</i> | 21-33123-564<br>(M39029/77-429)<br><i>(L-2035-AJ)</i> | 16           | M22520/2-01<br>with Positioner<br>M22520/2-35<br>or with<br>Daniels Positioner<br>K532 | M22520/4-01<br>with Positioner<br>M22520/4-02  | M81969/8-07<br>or<br>M81969/14-03          | M81969/8-08<br>or<br>M81969/14-03                            |   |                  |                     |
| Haveg 30-00761, 30-02024,<br>30-02033<br>Tensolite 24713/A955KK1,<br>26723/A955KK1  | 21-33122-562†<br><i>(L-2035-AN)</i>                   | 21-33123-562†<br><i>(L-2035-AR)†</i>                  |              |  |  | or<br>Amphenol<br>11-8674-16<br>11-8794-16 | or<br>Amphenol<br>11-8675-16<br>11-8795-16                   |   |                  |                     |
| Haveg 61-02051  | 21-33122-561†<br><i>(L-2035-AK) †</i>                 | 21-33123-561†<br><i>(L-2035-AM) †</i>                 |              |  |  | or<br>MS27495A16<br>or<br>MS27534-16       | or<br>MS27495R16<br>or<br>MS27534-16                         |   |                  |                     |
| RG-174A/U, RG-188A/U,<br>RG-316/U,<br>RG-161/U RG-187A/U,<br>RG-179B/U,<br>Haveg 8100207, Times<br>(HS-179)<br>AA3248, Teledyne 11299 | 21-33122-563<br>(M39029/76-424)<br><i>(L-2035-AD)</i> | 21-33123-563<br>(M39029/77-428)<br><i>(L-2035-AF)</i> | 12           | M22520/2-01<br>with Positioner<br>M22520/2-34<br>or with<br>Daniels Positioner<br>K323 | M22520/31-01<br>with Positioner<br>M22520/31-02<br>or<br>Daniels<br>GS-200 Tool<br>with Positioner<br>G2P330 | M81969/8-09<br>or<br>M81969/14-04          | M81969/8-10<br>or<br>M81969/14-04                            |   |                  |                     |
| RG-180B/U, RG-195A/U,<br>Raychem 9528A1318  | 21-33122-541<br>(M39029/28-409)<br><i>(L-2035-C)</i>  | 21-33123-541<br>(M39029/75-417)<br><i>(L-2035-D)</i>  |              |  |  | or<br>Amphenol<br>11-8674-12<br>11-8794-12 | or<br>Amphenol<br>11-8675-12<br>11-8795-12                   |   |                  |                     |
| Raychem 5022E5111   | 21-33122-543†<br><i>(L-2035-M) †</i>                  | 21-33123-543†<br><i>(L-2035-P)</i>                    |              |  |  | or<br>MS27495A12<br>or<br>MS27534-12       | or<br>MS27495R12<br>or<br>MS27534-12                         |   |                  |                     |
| Raychem 9530A5314   | 21-33122-544†<br><i>(L-2035R)</i>                     | 21-33123-544†<br><i>(L-2035-T) †</i>                  |              |  |  |  |  |   |                  |                     |
| Raychem 9527A1318   | 21-33122-545†<br><i>(L-2035-U) †</i>                  | 21-33123-545†<br><i>(L-2035-W)</i>                    |              |  |  |  |  |   |                  |                     |
| Raychem 9527A1314   | 21-33122-585<br><i>(L-2035-GG)</i>                    | 21-33123-585<br><i>(L-2035-GH)</i>                    |              |  |  |  |  |   |                  |                     |
| Gore GWN1159A, Nexans<br>RG179-DT   | 21-33122-547<br><i>(L-2035-X) †</i>                   | 21-33123-547<br><i>(L-2035-Z) †</i>                   |              |  |  |  |  |   |                  |                     |
| M/A-Com 5M2869-001  | 21-33122-589<br><i>(L-2035-GR)</i>                    | 21-33123-589<br><i>(L-2035-GT)</i>                    |              |  |  |  |  |   |                  |                     |
| RG-187A/U, RG-179B/U,<br>RG-174A/U,<br>RG-188A/U, RG-316/U,<br>RG-161/U<br>Haveg 8100207, Times<br>(HS-179)AA3248, Teledyne<br>11299  | 21-33102-23†<br><i>(L-1107-C)</i>                     | 21-33101-23†<br><i>(L-1107-G)</i>                     |              |  |  | 8  | M22520/2-01<br>with Positioner<br>M22520/2-31††<br>or solder | M22520/5-01<br>with die set<br>M22520/5-03 (A)<br>or M22520/5-08<br>(A)<br>M22520/5-35 (B)<br>or M22520/10-01<br>with Die Set<br>M22520/10-05<br>(A)<br>M22520/5-01<br>with die set<br>M22520/5-05 (A)<br>or M22520/5-19<br>(B)<br>or M22520/10-01<br>with Die Set<br>M22520/10-07<br>(A) | Hand<br>inserted | 11-9170<br>or<br>MS |
| RG-142B/U, RG-223/U   | 21-33102-24*<br><i>(L-1107-D)</i>                     | 21-33101-24*<br><i>(L-1107-H)</i>                     |              |  |  |  |  |   |                  |                     |

NOTE: SAE AS39029 supersedes MIL-C-39029  
 CRIMPING TOOLS: Italicized letters in parenthesis that follow positioner part numbers indicate applicable die closure. Commercial equivalents with the same die closure dimension may be used.  
 CHART CONTINUES ON NEXT PAGE

CONTACT ORDERING: Example number given in chart 21-33122-564 should be ordered as 21-033122-564; example number 21-33102-23 should be ordered as 21-033102-023. Adding Zeros is necessary for Amphenol ordering process on all contact numbers  
 † Consult Amphenol Aerospace for current release of this contact or instruction sheet if applicable.  
 †† When inner contact is installed by crimping only, 11-10134 Expander Tool Kit must be used to assemble rear insulator over contact.  
 \*\*Termination instructions are packaged with each contact and can be found on-line at: [www.amphenol-aerospace.com/serviceinstructions.asp](http://www.amphenol-aerospace.com/serviceinstructions.asp)

- 38999
- SJT
- 26482 Matrix 2
- 83723 III Matrix Pyle
- 5015 Crimp Rear Release Matrix
- 26500 Pyle
- Printed Circuit Board
- EMI Filter Transient
- Fiber Optics
- High Speed Contacts
- Options Others



### LJT-R, MIL-DTL-38999 Series I; TV-R, MIL-DTL-38999 Series III; Amphe-Lite and SJT-R Series, SAE AS39029 (28, 59, 60, 75, 76, 77), cont.

#### COAX CONTACTS FOR USE IN LJTR, TVR, AMPHE-LITE AND SJTR CONNECTORS, CONT.

| Cable  | Contact Part Number<br>(Termination Instruction Sheet)*** |   | Contact Size | Crimping Tools                                      |  | Installation Tools |               |
|--|---|---|--------------|---|--|--------------------|---------------|
|  | Pin   | Socket  |              | Inner Contact                                       | Crimp Ferrule  | Insertion          | Removal       |
| Haveg 51-03111, Tensolite 28895/2X1  | 21-33102-22<br>(L-1107-B)                                 | 21-33101-22<br>(L-1107-F)                                 | 8            | M22520/2-01 with Positioner M22520/2-31** or solder | M22520/5-01 with die set   | Hand inserted      | 11-9170 or MS |
| RG-180B/U, RG-195A/U, Raychem 9528A1318  | 21-33102-21 (M39029/60-367 Supersedes MS27536) (L-1107-A) | 21-33101-21 (M39029/59-366 Supersedes MS27535) (L-1107-E) |              |   | M22520/5-05 (B) or M22520/5-41 (B) or M22520/10-01 with Die Set M22520/10-07 (B)       |                    |               |
| RD-316 Double Shield (M17/152-00001)   | 21-33102-25<br>(L-1107-J)                                 | 21-33101-25<br>(L-1107-N)                                 |              | M22520/2-01 with Positioner M22520/2-31             | M22520/5-01 with Die Set M22520/5-37 (B) or M22520/10-01 with Die Set M22520/10-15 (A) |                    |               |
| Raychem 7524D5111-9 (triax cable - contact will terminate inner coax portion only) | 21-33102-26<br>(L-1107-M)                                 | 21-33101-26<br>(L-1107-M)                                 |              |   |  |                    |               |
| RG-400, ECS3C058A ECS352001  | 21-33102-27<br>(L-1286-B)                                 | 21-33101-27<br>(L-1293-B)                                 |              | M22520/2-01 with Positioner M22520/2-10             | M22520/5-01 with Die Set M22520/5-45 (A)   |                    |               |
| RG-58 (M17/155-00001), M17/028-RG-058  | 21-33102-29<br>(L-1107-AA)                                | 21-33101-29<br>(L-1107-Y)†                                |              | Solder  | M22520/5-01 with Die Set M22520/5-05 (B)   |                    |               |
| 5021D1331-0  | 21-33102-36<br>(L-1107-P)                                 | 21-33101-36†<br>(L-1107-Q)                                |              |   |  |                    |               |
| 5M2869-001 ESC432101   | 21-33102-37<br>(L-1107-V)                                 | 21-33101-37<br>(L-1107-W)                                 |              | M22520/2-01 with Positioner M22520/2-31             | M22520/5-01 with Die Set M22520/5-05 (B) or M22520/10-01 with Die Set M22520/10-07 (B) |                    |               |
| 5022A1311-0  | 21-33102-39<br>(L-1107-AC)                                | 21-33101-36†<br>(L-1107-AB)                               |              |   |  |                    |               |
| FA-19X   | 21-33652-1<br>(L-2091-A)                                  | 21-033653-1<br>(L-2091-B)                                 |              | M22520/2-01 with Positioner K1106                   | M22520/5-01 with Die Set Y25 (B)   |                    |               |
| T Flex-402   | 21-33102-41<br>(L-1107-AG)                                | 21-33101-41<br>(L-1107-AF)                                |              | Solder  | M22520/5-01 with Die Set M22520/5-05 (B)   |                    |               |

NOTE: SAE AS39029 supersedes MIL-C-39029

NOTE: Contacts can be ordered by part numbers given in chart  
 CRIMPING TOOLS: Italicized letters in parenthesis that follow positioner part numbers indicate applicable die closure. Commercial equivalents with the same die closure dimension may be used.

CONTACT ORDERING: Example number given in chart 21-33102-22 should be ordered as 21-033102-022; example number 21-33652-1 should be ordered as 21-033652-001. Adding Zeros is necessary for Amphenol ordering process on all contact numbers.

† Consult Amphenol Aerospace for current release of this contact or instruction sheet if applicable

\*\*When inner contact is installed by crimping only. 11-10134 Expander Tool Kit must be used to assemble rear insulator over contact.

\*\*\*Termination instructions are packaged with each contact and can be found on-line at: [www.amphenol-aerospace.com/serviceinstructions.asp](http://www.amphenol-aerospace.com/serviceinstructions.asp)

38999  
III  
II  
I  
SJT

26482  
Matrix 2

83723 III  
Matrix  
Pyle

5015  
Crimp Rear  
Release Matrix

26500 Pyle

Printed  
Circuit Board

EMI Filter  
Transient

Fiber Optics

High Speed  
Contacts

Options  
Others

**Amphenol® Matched Impedance Size 12 Coaxial Contacts for RF/Microwave, High Frequency and High Performance Requirements**

The matched impedance coax contact is available in size 12. It incorporates a captivated inner contact which “snaps into” the outer contact preventing displacement or pull back of the inner contact in situations where the cable may be bent.

**TYPICAL MATCHED IMPEDANCE COAX SOCKET CONTACT**  
has socket outer contact with a captivated pin inner contact

**TYPICAL MATCHED IMPEDANCE COAX PIN CONTACT**  
has pin outer contact with a captivated socket inner contact

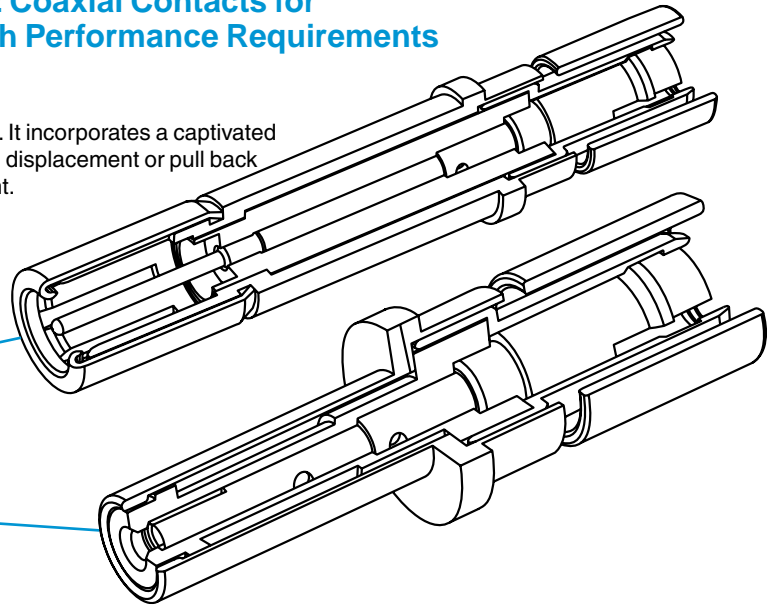

Design features and benefits of the Matched Impedance:

- For use in 90 degree angle or bent cable applications
- Provides 50 ohm matched impedance resulting in low VSWR and low insertion loss
- Frequency range for a mated pair extends to 3 GHz and beyond, higher than other coaxial contacts previously offered.
- Ideally suited for D38999 high performance and MIL-STD-1760 high band coaxial contact requirements

**High Performance Size 12 Coax  
50 Ohm matched**

**LJT-R, MIL-DTL-38999 Series I, JT-R, MIL-DTL-38999 Series II, and TV-R, MIL-DTL-38999 Series III**

| Use with Cable                          | Comment                       | Pin<br>(Termination Instruction Sheet)** | Socket<br>(Termination Instruction Sheet)** |
|---|-------------------------------|--|---|
| RG316, T-Flex-405                       | M39029/102/103                | 21-33651-11 (L-2092-C)                   | 21-33650-11 (L-2092-C)                      |
| RG-316, T-Flex-405                      | JT-R, MIL-DTL-38999 Series II |  | 21-33729-11 (L-2092-P)                      |
| RD316, Filotex, ET124962, M17/152-00001 | M39029/102/103 Type           | 21-33651-17 (L-2092-F)                   | 21-33650-17 (L-2092-F)                      |
| JN1088WT                                | JN1104*50C                    | 21-33213-42                              | 21-33214-42 (L-2092-D)                      |
| PAN6422XQ                               | PAN6841*50C                   | 21-33651-12 (L-2092-E)                   | 21-33650-12                                 |
| RG178, Gore CXN 3403                    | M39029/102/103 Type           | 21-33651-18 (L-2092-K)                   | 21-33650-18 (L-2092-K)                      |
| RG178, Gore CXN 3403                    | JT-R, MIL-DTL-38999 Series II |  | 21-33729-18 (L-2092-K)                      |
| SFT-316-TR                              | M39029/102/103 Type           | 21-33651-22 (L-2092-N)                   | 21-33650-22 (L-2092-N)                      |
| Semflex SW060                           | M39029/102/103 Type           | 21-33651-25                              | 21-33650-25                                 |
| Semflex SW086 (solid inner conductor)   | M39029/102/103 Type           | 21-33651-26                              | 21-33650-26                                 |

\* Add P or S for pin or socket

CONTACT ORDERING: Example number given in chart 21-33651-11 should be ordered as 21-033651-011. Adding Zeros is necessary for Amphenol ordering process on all contact numbers.

\*\*\*Termination instructions are packaged with each contact and can be found on-line at:  
[www.amphenol-aerospace.com/serviceinstructions.asp](http://www.amphenol-aerospace.com/serviceinstructions.asp)

**Matched Impedance Coax Contact Performance:**

Electrical Specifications:

- Contact impedance = 50 ohms nominal
- Frequency range = 0–3 GHz Operable at higher frequencies depending on cable selection. Consult Amphenol for details.
- Dielectric withstanding voltage (for a mated pair):  
At sea level = 1000 VRMS  
At 50, 000 ft. = 250 VRMS
- Insulation resistance: 5 gigaohms min. @ 25°C
- VSWR: 1.20 + .04F (F in GHz) max. up to 3 GHz
- Insertion Loss:  $.11 \sqrt{f \text{GHz}} \text{ dB max.}$

Environmental Specifications:

- Thermal limits: –55 ° to 200°C

Mechanical Specifications:

- Mating: slide-on
- Mounting: conforms to M39029/102 & /103 envelope dimensions

38999  
SJT I II III

26482  
Matrix 2

83723 III  
Matrix Pyle

5015  
Crimp Rear Release Matrix

26500 Pyle

Printed  
Circuit Board

EMI Filter  
Transient

Fiber Optics

High Speed  
Contacts

Options  
Others

# Typical Contact Installation Instructions for Coax Contacts

The following is an example of a contact instruction sheet that would be shipped within the package of contacts for a Crimp, Size 12 Coax Contact for use in Subminiature, D38999 connectors. The sheet provides detailed instructions for assembling the component parts and for crimping the contact to coaxial cable, along with the recommended cable and tooling to be used. Installation instructions are included within all contacts for D38999 connectors. For installation instructions for other connector series, there are separate documents (not included in packaging of parts) as follows: L- 633 for Miniature solder types, L-613 for Miniature SE types, L-660 for Miniature CE types, and L-650 for MS/Standard and Heavy Duty types. For any other instructions needed, consult Amphenol. Most installation instructions can be found on-line at [www.amphenol-aerospace.com](http://www.amphenol-aerospace.com) (from home page, go to Service Instructions and enter contact part number or instruction sheet number).

**21-33651-11 (PIN)**  
**21-33650-11 (SOCKET)**

Contact, Pin and Socket, Coaxial,  
Type LJT-R & TV-R, (MIL-DTL-38999 Series I & III) Crimp, Size 12  
Installation Instructions

See table on reverse side for coaxial cable recommended and crimp tool information.

- A. 1. Slide outer crimp ferrule over cable outer jacket as shown.
2. Strip cable outer braid as illustrated. Ends must be cut cleanly and at right angles to the axial plane of the cable. The cable must not be deformed while making cuts.
3. Flare outer braid, then strip cable dielectric as shown.
- B. 1. Assemble inner contact assembly over cable center conductor and cable dielectric until inside bore of bushing butts against cable dielectric.
2. Cable center conductor must be visible through the inspection hole in the inner contact wire well.
3. Crimp inner contact wire well using crimp tool listed in table.
- C. 1. Carefully slide outer contact assembly over inner contact assembly and under cable outer braid until inner contact butts against insulator shoulder as illustrated. (Inner contact assembly will snap into the locked position when fully assembled inside the outer contact assembly.)
2. Bring outer crimp ferrule forward over cable outer braid as illustrated. (Continue to push the inner contact assembly fully forward while bringing the outer crimp ferrule into position.)
3. Crimp outer crimp ferrule using crimp tool listed in table (.156 Max. over ferrule after crimping). Trim excess braid ahead of crimp ferrule, if necessary.

**21-33651-11 (PIN)**  
**21-33650-11 (SOCKET)**

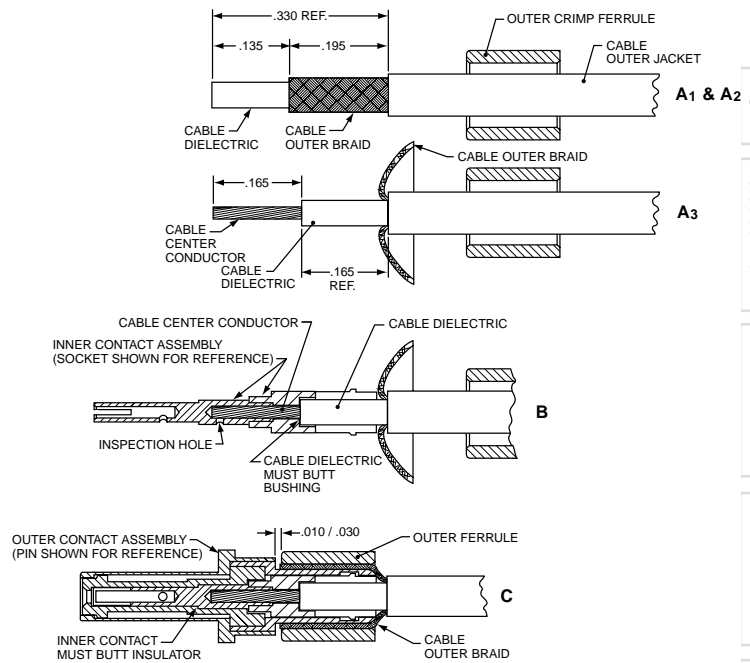

**CONTACT INSERTION INTO CONNECTOR**

Using insertion tool (part number M81969/8-09 or M81969/14-04), insert contact assembly into rear connector grommet hole. Contact must be aligned with hole and not inserted at an angle. Push forward until contact is felt to snap into position within insert. Remove tool.

**CONTACT REMOVAL FROM CONNECTOR**

Position removal tool (part number M81969/8-10 or M81969/14-04) around cable and slide tool down wire until tool tips enter rear grommet and come to a positive stop. Hold tool tip firmly against positive stop on contact, grip wire and simultaneously remove tool, contact and cable.

L-2092-C  
October 2001

FSCM77820

| Amphenol®<br>Part Number | Description                                  | Coaxial Cable<br>Accommodated | Tools           |         |                         |               |  |
|--------------------------|--|-------------------------------|-----------------|---------|-------------------------|---------------|--|
|                          |  |                               | Inner Contact   |         |                         | Outer Contact |  |
|                          |  |                               | Crimp Tool      | Setting | Positioner<br>(Daniels) | Tool          | Positioner                               |
| 21-33651-11              | Matched Impedance*<br>Size 12 Coax<br>Pin    | RG316<br>(M17/113-RG316)      | MH992 (Daniels) | 5       | K1360                   | M22520/5-01   | M22520/5-03 (A)<br>or<br>M22520/5-35 (B) |
|                          |  | RG179<br>(M17/094-RG179)      | MH992 (Daniels) | 4       | K1360                   |               |  |
| 21-33650-11              | Matched Impedance*<br>Size 12 Coax<br>Socket | RG316<br>(M17/113-RG316)      | MH992 (Daniels) | 5       | K1360                   |               |  |
|                          |  | RG179<br>(M17/094-RG179)      | MH992 (Daniels) | 4       | K1360                   |               |  |

\* Matched Impedance applies when contacts are terminated to RG316 cable only.

III  
II  
I  
SJT  
38999

Matrix 2  
26482

Matrix Pyle  
83723 III

Release Matrix  
5015  
Crimp Rear

26500 Pyle

Printed  
Circuit Board

EMI Filter  
Transient

Fiber Optics

High Speed  
Contacts

Options  
Others

### Amphenol® High Frequency Contacts

Amphenol and SV Microwave (an Amphenol company) offer DC to 40 GHz high frequency size 8, 12 and 16 coaxial contacts for the D38999 Series III housing and standard inserts. These contacts allow any application to continue to use the D38999 connector and be able to expand the use to include the microwave transmission lines. Features include:

- Superior electrical performance and high frequency capability
- Blindmate advantage and maintenance of an accurate phase length when mated
- Can be terminated to a multiple of cable types depending on the application
- Uses standard interfaces based on MIL-STD-348, and can be installed in any MIL-DTL-38999 size 8, 12 or 16 insert
- Unique "Float Mount" technology allows for consistent microwave performance while maintaining tight mechanical tolerances



Subminiature MIL-DTL-38999 Series III Connector with Size 8 High Frequency Contacts

### HIGH FREQUENCY CONTACTS SPECIFICATIONS

#### Electrical

**(Mated pair size 8 - RG 405 Semi-Rigid Cable)**

|                                 |                       |
|---------------------------------|-----------------------|
| Impedance                       | 50 Ω                  |
| Frequency Range                 | DC - 40 GHz           |
| VSWR                            | 1.05 +.01 (freq. GHz) |
| Insertion Loss                  | 0.03 √(freq. GHz)     |
| Insulation Resistance (Min.)    | 10,000 M Ω            |
| Contact Resistance (Max.)       |                       |
| Center conductor:               | 6.0 mΩ                |
| outer conductor:                | 3.0 mΩ                |
| outer to cable:                 | 0.5 mΩ                |
| Dielectric Withstanding Voltage | 1,000 VRMS            |
| Corona Extinction Voltage       | 250 VRMS              |
| RF High Potential Voltage       | 500 VRMS              |
| RF Leakage                      | - (80-freq. GHz)      |

#### Materials and Finish

|                      |   |
|----------------------|---|
| Body and Sleeve      | Stainless steel per AMS-5640 Alloy UNS S30300 Type 1  |
| Ferrule              | Brass per ASTM B16, Alloy UNS C36000  |
| Contact & Lock Ring  | Beryllium copper per ASTM B196 Alloy UNS C17300, Td04   |
| Insulator            | PTFE per ASTM D1710, Type 1, Grade 1, Class B   |
| Spring               | Stainless steel per ASTM A313 Type 631  |
| Rear Body & Contacts | Gold per ASTM B488 Type II, Code C, Class 1.27; over Nickel per AMS-QQ-N-290 Class 1 (60μ inches); over Copper per MIL-C-14550 (10μ inches) Passivated per AMS-2700, Type 2 |

#### Environmental

|                                |   |
|--------------------------------|---|
| Temperature Range              | -65°C to +125°C                                       |
| Corrosion (Salt Spray)         | MIL-STD-202, Method 101, Condition B                  |
| Vibration                      | MIL-STD-202, Method 204, Condition D, 20 Gs           |
| Shock                          | MIL-STD-202, Method 213, Condition 1, 100 Gxs         |
| Thermal Shock                  | MIL-STD-202, Method 107, Condition B, -65°C to +125°C |
| Moisture Resistance            | MIL-STD-202, Method 106, Less step 7B                 |
| Barometric Pressure (Altitude) | MIL-STD-202, Method 105, Condition C, 70,000 ft.      |

### HIGH FREQUENCY COAX CONTACTS FOR USE IN D38999, SERIES III CONNECTORS

| High Frequency Amphenol Part Number<br>(Termination Instruction Sheet) | Interface     | Frequency | For use with Cable  | Type   | Cavity Size | Piggyback Grommet |
|--|---------------|-----------|---------------------|--------|-------------|-------------------|
| 21-033449-01HF<br>(300-17-008)   | BMZ           | 40 GHz    | TFLEX-405           | Socket | 8           | 21-033321-007     |
| 21-033448-01HF<br>(300-17-008)   |               |           |                     | Pin    |             |                   |
| 21-033449-02HF<br>(300-89-009)   | BMZ           | 18 GHz    | TFLEX-405           | Socket | 8           | 21-033321-007     |
| 21-033448-02HF<br>(300-89-009)   |               |           |                     | Pin    |             |                   |
| 21-033449-03HF<br>(300-89-008)   | BMZ           | 12 GHz    | RG-400/<br>RG-142   | Socket | 8           | 21-033321-009     |
| 21-033448-03HF<br>(300-89-008)   |               |           |                     | Pin    |             |                   |
| 21-033449-04HF<br>(300-89-002)   | BMZ           | 18 GHz    | TFLEX-402           | Socket | 8           | 21-033321-010     |
| 21-033448-04HF<br>(300-89-002)   |               |           |                     | Pin    |             |                   |
| 21-033449-06HF   | BMA           | 26.5 GHz  | TFLEX-405           | Socket | 8           | 21-033321-007     |
| 21-033448-06HF   |               |           |                     | Pin    |             |                   |
| 21-033449-07HF   | BMA           | 26.5 GHz  | TFLEX-402           | Socket | 8           | 21-033321-010     |
| 21-033448-07HF   |               |           |                     | Pin    |             |                   |
| 21-033449-08HF   | BMZ-75<br>Ohm | 2 GHz     | LMR-240-75          | Socket | 8           | 21-033321-008     |
| 21-033448-08HF   |               |           |                     | Pin    |             |                   |
| 21-033449-09HF   | SMPPM         | 65 GHz    | TFLEX-405           | Socket | 12          | N/A               |
| 21-033448-09HF   |               |           |                     | Pin    |             |                   |
| 21-033449-10HF   | SMPS          | 65 GHz    | 0.047 Dia.<br>Cable | Socket | 16          | N/A               |
| 21-033448-10HF   |               |           |                     | Pin    |             |                   |

# Twinax Contacts for MIL-DTL-38999

## General Description, Application Data - Size 10 & 12

**Amphenol® Twinax Contacts** -Were designed for use with twinax cable in Data Bus systems. Twinax contacts provide the following benefits:

- Protection from magnetic interference
- Protection from electrostatic interference including nuclear electromagnetic pulse
- Meets parameters defined by MIL-STD-1553B
- Maintains shield integrity through a multi-pin circular connector and does not require contact polarization within the insert

### SIZE 10 & 12 CONCENTRIC TWINAX CONTACTS

The size 12 concentric twinax contact interface was developed for JN1104 EuroFighter contacts, and can be used in any size 12 cavity M38999 I, II or III or SJT connector.

Features:

- Operating temperature -55°C to 175°C
- Pins are scoop-proof
- Meets performance levels of M38999 connector
- 4 components, gold plated crimp termination
- For use with a variety of cables (See chart below)

### TYPICAL ELECTRICAL PERFORMANCE

#### Size 10 & 12 Concentric Twinax Contacts

Voltage Rating: 500 Vrms max. @ sea level

Contact Resistance:

Center @ 1 Amp, 55 millivolts max. voltage drop @ 25°C

Intermediate @ 1 Amp, 55 millivolts max. voltage drop @ 25°C

Outer @ 12 Amps, 85 millivolts max. voltage drop @ 25°C

Operating Frequency: 0-30 MHz

Dielectric Withstanding Voltage:

Center to Intermediate 800 VAC Rms @ Sea Level

Intermediate to Outer 500 VAC Rms @ Sea Level

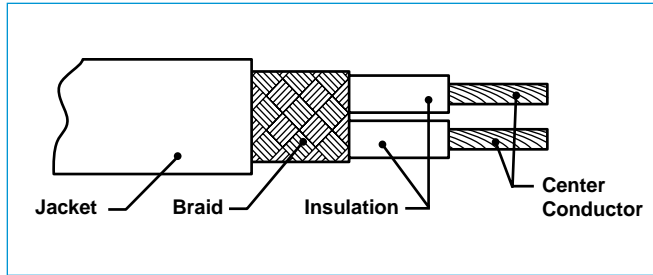

Cable Illustration - Twinax Contact



Concentric Twinax Contacts Size 12

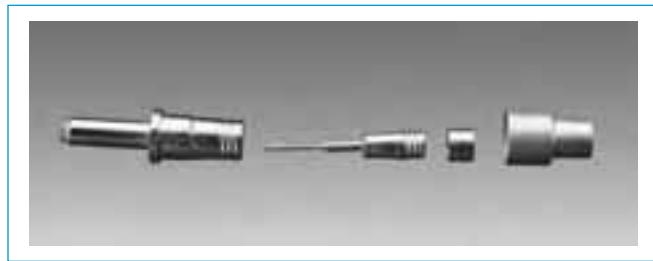

Unassembled Components of Size 12 Concentric Twinax Contact

| SIZE 10 & 12 CONCENTRIC TWINAX CONTACTS FOR USE IN D38999 CONNECTORS |   |                             |              |  |                      |
|--|---|-----------------------------|--------------|--|----------------------|
| For use with Cable   | Concentric Twinaxial Contact Part Number<br>(Termination Instruction Sheet)** |                             | Contact Size | Comments   | Connector Series     |
|  | Pin   | Socket                      |              |  |                      |
| M17/176-00002, ST5M1212-002  | 21-33909-25<br>(L-2092-G)   | 21-33908-25<br>(L-2092-G)   | 12           | JN1104 Interface                                 | D38999 Series I, III |
| 0024A0024, Fileca F2709-13-CA  | 21-33909-28<br>(L-2092-G)   | 21-33908-28<br>(L-2092-G)   |              |  |                      |
| EPD32263A, 10612, GSC-12-2548-00                                     | 21-33909-29<br>(L-2092-H)   | 21-33908-29<br>(L-2092-H)   |              |  |                      |
| ASNE0849, 5PTM1T04-1   | 21-33909-81<br>(L-2092-AB)  | 21-33908-81<br>(L-2092-AB)  |              |  |                      |
| VG95218T023D002  | 21-33909-91<br>(L-2092-AC)  | 21-33908-91<br>(L-2092-AC)  |              |  |                      |
| VG95218T023D002  | 21-33909-101<br>(L-2092-AC)   | 21-33908-101<br>(L-2092-AC) |              | Same as -91 except new ferrule with wire support |                      |
| M17/176-00002, GSC-12-2549-00  |   | 21-33640-25<br>(L-2092-W)   | 12           | JN1104 Interface                                 | D38999 Series II     |
| 0024A0024  |   | 21-33640-28<br>(L-2092-V)   |              |  |                      |
| 5M2022-003   | 21-33844-1<br>(L-1255-A)  | 21-33843-1<br>(L-1255-B)    | 10           | Supplied with Thermal fit sleeve                 | D38999 Series I, III |

CONTACT ORDERING: Example number given in chart above 21-33909-25 should be ordered as 21-033909-025; example number 21-33843-1 should be ordered as 21-033843-001. Adding Zeros is necessary for Amphenol ordering process on all contact numbers.

\*\*Termination instructions are packaged with each contact and can be found on-line at: [www.amphenol-aerospace.com/serviceinstructions.asp](http://www.amphenol-aerospace.com/serviceinstructions.asp)

III  
II  
I  
SJT  
38999

Matrix 2  
26482

Matrix Pyle  
83723 III

Crimp Rear Release Matrix  
5015

26500 Pyle

Printed Circuit Board

EMI Filter Transient

Fiber Optics

High Speed Contacts

Options Others



- 38999  
SJT I II III
- 26482  
Matrix 2
- 83723 III  
Matrix Pyle
- 5015  
Crimp Rear  
Release Matrix
- 26500 Pyle
- Printed  
Circuit Board
- EMI Filter  
Transient
- Fiber Optics
- High Speed  
Contacts
- Options  
Others

High performance connectors within the D38999 families are the most commonly used connectors for incorporation of Twinax contacts. These connectors offer wide versatility in insert arrangements for not only concentric Twinax contacts, but also coax, triax, PCB, wire wrap, thermocouples and EMI filter contacts.

Other connectors available with concentric Twinax contacts:

- Wire Integrated Connectors (WICS) for Data Bus Systems. Consult Amphenol Aerospace, Sidney, NY.
- ARINC 404, ARINC 600 and R27 Series rectangular connectors. Supplied by Amphenol Canada.

### SIZE 8 CONCENTRIC TWINAX CONTACTS

The size 8 concentric Twinax contact was developed for use in MIL-STD-1553 Airborne multiplex data bus applications which require high performance interconnect characteristics in multi-pin connectors. Ideal for this application need is the high performance Tri-Start connector with its fully scoop-proof feature of recessed pins. The concentric Twinax contact is crimp terminable to twisted shielded cable. Features include:

- Provides protection from magnetic and electrostatic interference including nuclear electromagnetic pulse
- Maintains shield integrity through a multi-pin circular connector and does not require contact polarization within the insert
- 175°C rated and meets performance levels of MIL-DTL-38999 Series III connectors
- MIL-C-17/176-00002 cable termination
- Gold plated full crimp termination contacts qualified to M39029/90 & /91
- Integral part of the MIL-STD-1760 interconnection system
- Also available in modified but intermateable versions for termination to a host of cables (See chart on next page)

### TYPICAL ELECTRICAL PERFORMANCE

#### Size 8 Concentric Twinax Contacts

Voltage Rating: 500 Vrms max. @ sea level

Contact Resistance:

Center @ 1 Amp, 55 millivolts max. voltage drop @ 25°C

Intermediate @ 1 Amp, 55 millivolts max. voltage drop @ 25°C

Outer @ 12 Amps, 75 millivolts max. voltage drop @ 25°C

Operating Frequency: 0–20 MHz

Dielectric Withstanding Voltage:

Center to Intermediate: 1000 VAC Rms @ Sea Level

Intermediate to Outer: 500 VAC Rms @ Sea Level

### SHORT PROFILE TWINAX CONTACT OPTION

A Short Profile size 8 Twinax is available that can be used with a low profile right angle backshell and can offer increased packaging efficiency. Consult Amphenol Aerospace for further information.



MIL-DTL-38999 Series III Connector with Twinax Contacts and Standard Contacts



Concentric Twinax Contacts Size 8



Short Profile Twinax vs Standard Length Twinax Contact



# Twinax Contacts for MIL-DTL-38999

## General Description, Application Data - Size 8, cont.



### SIZE 8 CONCENTRIC TWINAX CONTACTS FOR USE IN D38999 CONNECTORS

| For use with Cable   | Size 8 Concentric Twinaxial Contact Part Number<br>(Termination Instruction Sheet)** |                             | Comments   | Connector Series     |
|--|--|-----------------------------|--|----------------------|
|  | Pin  | Socket                      |  |                      |
| M17/176-00002, 5PTM1T04-2  | 21-33190-529<br>(L-1253-A)   | 21-33191-530<br>(L-1253-B)  | M39029/90/91 (Amphenol)<br>Supplied with heat shrink seal    | D38999 Series I, III |
| M17/176-00002  | T3-46T08-LD<br>(PN-430)  | T3-47T08-LD<br>(PN-430)     | M39029/90/91 (Pyle)<br>Supplied with heat shrink seal        |                      |
| M17/176-00002  | 21-33190<br>(L-1253-A)   | 21-33191<br>(L-1253-B)      | Without seals  |                      |
| M17/176-00002  | 21-33190-1<br>(L-1253-A)   | 21-33191-1<br>(L-1253-B)    | Supplied with piggyback grommet seal                         |                      |
| Raychem 10612, 5M2022-003  | 21-33190-26<br>(L-1253-AA)   | 21-33191-26†                | Without seals  |                      |
| Raychem 10614, EPD22189B, 7724C8664, 05A0771, GC875TM24H, T10971           | 21-33190-22<br>(L-1253-C)  | 21-33191-22<br>(L-1253-D)   | Without seals  |                      |
| Raychem 10613, PAN711-6421, 23089/RC                                       | 21-33190-27<br>(L-1253-K)  | 21-33191-27<br>(L-1253-L)   | Supplied with heat shrink seal                               |                      |
| Raychem 10613, PAN711-6421, 23089/RC                                       | 21-33190-29<br>(L-1253-K)  | 21-33191-29<br>(L-1253-L)   | Supplied with piggyback grommet seal                         |                      |
| Raychem 10613, PAN711-6421, 23089/RC                                       | 21-33190-30<br>(L-1253-K)  | 21-33191-30<br>(L-1253-L)   | Without seals  |                      |
| GSC-12-2548-00, 7726D0664  | 21-33190-40<br>(L-1253-S)  | 21-33191-40<br>(L-1253-T)   | Supplied with heat shrink sleeve                             |                      |
| Axon P517417   | 21-33190-81<br>(L-1253-W)†   | 21-33191-81<br>(L-1253-Y)†  | Supplied with piggyback grommet seal                         |                      |
| Raychem 10612, 5M2022-003  | 21-33190-261<br>(L-1253-AA)  | 21-33191-261†               | Supplied with piggyback grommet seal                         |                      |
| Raychem 10612, 5M2022-003  | 21-33190-262<br>(L-1253-AA)  | 21-33190-262†               | Supplied with heat shrink seal                               |                      |
| Raychem 10614, 7724C8664   | T3-46TB08-LD<br>(PN-494)   | T3-47TB08-LD<br>(PN-494)    | Without seals  |                      |
| 7820D0111 (20 AWG)   | T3-467C08-LD<br>(PN-537)   | T3-477C08-LD<br>(PN-537)    | Without seals  |                      |
| Gore CXN2268   | T3-46TE08-LD<br>(PN-1001)  | T3-47TE08-LD<br>(PN-1001)   | Short profile<br>Supplied with heat shrink seal (.450)       |                      |
| M17/176-00002  | T3-46TD08-LD<br>(PN-1000)  | T3-47TD08-LD<br>(PN-1000)   | Short profile<br>Supplied with heat shrink seal (.450)       |                      |
| M17/176-00002  | 21-33910-15†<br>(PN-1005)  | 21-33922-15<br>(PN-1005)    | Short profile<br>Without seals (.263)                        |                      |
| M17/176-00002  | 21-33617-1<br>(REF PN-100)   |                             | Short profile<br>Supplied with piggyback grommet seal (.450) |                      |
| Gore CNX2702   | T3-46TF08-LD<br>(PN-1002)  | T3-47TF08-LD<br>(PN-1002)   | Short profile<br>Supplied with heat shrink seal (.450)       |                      |
| M17/176-00002  |  | P-209546-27†                | Short profile<br>Without seals (.303)                        |                      |
| S280W502-1, Fileca F2709-13-CA, HS5930, Raychem 10602 0024G0024, 0024A0024 | 21-33190-70<br>(L-1253-U)  | 21-33191-70<br>(L-1253-V)   | Without seals  |                      |
| S280W502-1, Fileca F2709-13-CA, HS5930, Raychem 10602 0024G0024, 0024A0024 | 21-33190-71<br>(L-1253-U)  | 21-33191-71<br>(L-1253-V)   | Supplied with piggyback grommet seal                         |                      |
| S280W502-1, Fileca F2709-13-CA, HS5930, Raychem 10602 0024G0024, 0024A0024 | 21-33190-72<br>(L-1253-U)  | 21-33191-72<br>(L-1253-V)   | Supplied with heat shrink seal                               |                      |
| 0024A0311, PIC E10244  | 21-33190-90†   | 21-33191-90<br>(L-1253-AD)  | Without seals  |                      |
| 0024A0311, PIC E1024   | 21-33190-91†   | 21-33191-91<br>(L-1253-AD)  | Supplied with piggyback grommet seal                         |                      |
| 0024A0311, PIC E1024   | 21-33190-92†   | 21-33191-92<br>(L-1253-AD)  | Supplied with heat shrink seal                               |                      |
| M17/176-00002  | 21-33190-625<br>(L-1253-AG)  | 21-33191-628<br>(L-1253-AG) | M39029/113-625 & /114-628<br>Supplied with heat shrink seal  |                      |

III  
II  
I  
SJT  
38999

Matrix 2  
26482

Matrix  
Pyle  
83723 III

Release Matrix  
Crimp Rear  
5015

26500 Pyle

Printed  
Circuit Board

EMI Filter  
Transient

Fiber Optics

High Speed  
Contacts

Options  
Others

CONTACT ORDERING: Example number given in chart above 21-33190-529 should be ordered as 21-033190-529; example number 21-33190-1 should be ordered as 21-033190-001. Adding Zeros is necessary for Amphenol ordering process on all contact numbers.

\*\*Termination instructions are packaged with each contact and can be found on-line at: [www.amphenol-aerospace.com/serviceinstructions.asp](http://www.amphenol-aerospace.com/serviceinstructions.asp)

† Consult Amphenol Aerospace for current release of this contact or instruction sheet if applicable.

**Amphenol® Triax Contacts** -Provide additional shielding when terminated to triax cable having solid or stranded center conductors. Amphenol supplies triax contacts in sizes 8, 10 and 12 and they are ideally suited for use in D38999 Series I, II and III circular connectors.

Features and benefits of Amphenol triax contacts include:

- Incorporates three conductors, designed for use with triax cable
- Each of the three conductors are separated by dielectric insulation to isolate ground planes
- Shielding effectiveness is improved with two isolated shields
- May be specified for direct connection to printed circuit boards
- May be mixed with coax, twinax and power contacts in a single connector



Cable Illustration - Triax Contact



Triax Size 8 Pin Contact



Triax Size 12 Socket Contact

### TYPICAL ELECTRICAL PERFORMANCE

#### Size 8, 10 and 12 Triax Contacts

Center @ 1 Amp, 120 millivolts max. voltage drop @ 25°C  
 Intermediate @ 1 Amp, 60 millivolts max. voltage drop @ 25°C  
 Outer @ 12 Amps, 90 millivolts max. voltage drop @ 25°C

Operating Frequency:

Size 12: 0-30 MHz  
 Size 10: 0-300 MHz  
 Size 8: 0-500 MHz

Dielectric Withstanding Voltage:

Center to Intermediate 800 VAC Rms @ Sea Level  
 Intermediate to Outer 500 VAC Rms @ Sea Level

Insulation Resistance:

1000 megohms minimum @ 25°C

### SIZE 8, 10 & 12 TRIAX CONTACTS FOR USE IN D38999 SERIES I & III CONNECTORS

| For use with Cable  | Size | Size 8, 10, 12 Triax Contact Part Number<br>(Termination Instruction Sheet)** |  | Comments  |
|---|------|---|--|---|
|   |      | Pin   | Socket                                   |   |
| 5M2397-002, 81264-02, RGX-179, RT-179, Champlain 81-00321A, Tensolite 28883/02060X-1(LD), 7528A5314, Thermatics 12447, 28883/02060X-1 | 8    | 21-33198-3<br>(L-1254-F)  | 21-33197-3<br>(L-1254-E)                 |   |
| 752866314, 7528G6314  | 8    | 21-33198-11<br>(L-1254-V)   | 21-33197-11<br>(L-1254-T)                |   |
| 5M2559-001, 81264-01, Tensolite 28598/9J063T-1, Teledyne 13809, Cheminax 9530F5214  | 8    | 21-33198-4<br>(L-1254-D)  | 21-33197-4<br>(L-1254-C)                 |   |
| ST5M1323-001, Champlain 81-00700, Teledyne 11914/1, Times AA6603, Tensolite 26895/90334X-1  | 8    | 21-33198-10<br>(L-1254-S)   | 21-33197-10<br>(L-1254-S)                |   |
| 5M2397-002  | 10   | 21-33800-1<br>(L-1256-A)  | 21-33801-1<br>(L-1256-B)                 |   |
| JN1088WU (75Ω), JN1088WT (50Ω)  | 12   | 21-33909-12<br>(L-1256-J)   | 21-33908-12<br>(L-1256-J)                | JN1104 Interface  |
| GSC-03-81497-00 (75Ω)   | 12   | 21-33909-23<br>(L-1256-M)   | 21-33908-23<br>(L-1256-M)                | Replaced by -33 with improved rear insulator                      |
| GSC-03-81497-00 (75Ω)   | 12   | 21-33909-33<br>(L-1256-P)   | 21-33908-33<br>(L-1256-P)                | JN1104 Interface  |
| Harbour TRX179, Times Microwave AA-6151 (RT-179), Axon RGX-179, 540-1050-000 (75Ω)  | 12   | 21-33909-71<br>(L-1256-AA)  | 21-33908-71<br>(L-1256-AA)               |   |
| 10602 (Twinax)  | 8    | 21-33724-15<br>(L-1255-C)   | (Consult with Amphenol for availability) | Special design with triax mating end and twinax cable termination |

CONTACT ORDERING: Example number given in chart 21-33198-3 should be ordered as 21-033198-003; example number given in chart 21-33198-10 should be ordered as 21-033198-010. Adding Zeros is necessary for Amphenol ordering process on all contact numbers.

\*\*Termination instructions are packaged with each contact and can be found on-line at:  
[www.amphenol-aerospace.com/serviceinstructions.asp](http://www.amphenol-aerospace.com/serviceinstructions.asp)

### Amphenol® Printed Circuit Tail Contacts

are currently supplied as follows:

- 8, 12 and 16 Coax
- 8, 10 and 12 Twinax
- 8 Triax (socket only)

PC Tail shielded contacts provide a cost effective packaging solution for limited space applications where connectors are attached to printed circuit boards. High reliability is assured with factory pre-assembled contacts and standardization termination to the board. PC Tail contacts are available for MIL-DTL-38999 Series I and III circular connectors and also for ARINC 404, ARINC 600 and R27 rectangular connectors. The following pages (402 & 403) show the available PC Tail contact part numbers for 38999 Circular connectors. See page 412 Rectangular Section of this catalog for information on twinax contacts for ARINC Rectangular connectors along with compatible cable terminations. Consult Amphenol Aerospace for further information on the applicable tooling for these contacts.



PC Tail Coax and Twinax Contacts for Attachment to Printed Circuit Boards

### TYPICAL ELECTRICAL PERFORMANCE

#### Size 8, 12 & 16 PC Tail Coax Contacts

Contact Resistance:  
 Center @ 1 Amp, 55 millivolts max. voltage drop @ 25°C  
 Outer @ 1 Amp, 55 millivolts max. voltage drop @ 25°C  
 Operating Frequency: 0–500 MHz  
 Dielectric Withstanding Voltage:  
 Center to Outer 500 VAC Rms @ Sea Level  
 Insulation Resistance  
 1,000 megohms minimum @ 25°C

### TYPICAL ELECTRICAL PERFORMANCE

#### Size 8, 10 & 12 PC Tail Twinax Contacts

Contact Resistance:  
 Center @ 1 Amp, 55 millivolts max. voltage drop @ 25°C  
 Intermediate @ 1 Amp, 55 millivolts max. voltage drop @ 25°C  
 Outer @ 1 Amp, 55 millivolts max. voltage drop @ 25°C  
 Operating Frequency: 0–20 MHz  
 Dielectric Withstanding Voltage:  
 Center to Intermediate 500 VAC Rms @ Sea Level  
 Intermediate to Outer 500 VAC Rms @ Sea Level  
 Insulation Resistance  
 1,000 megohms minimum @ 25°C

### TYPICAL ELECTRICAL PERFORMANCE

#### Size 8 PC Tail Triax Contacts

Contact Resistance:  
 Center @ 1 Amp, 55 millivolts max. voltage drop @ 25°C  
 Intermediate @ 1 Amp, 55 millivolts max. voltage drop @ 25°C  
 Outer @ 1 Amp, 55 millivolts max. voltage drop @ 25°C  
 Operating Frequency: 0–500 MHz  
 Dielectric Withstanding Voltage:  
 Center to Intermediate 500 VAC Rms @ Sea Level  
 Intermediate to Outer 500 VAC Rms @ Sea Level  
 Insulation Resistance  
 1,000 megohms minimum @ 25°C



Size 8, PC Tail Twinax Socket Contact for use in D38999 Connectors



D38999 Connector with PC Tail Coax Contacts, Sealing Plugs in unused contact cavities and PC Tail Alignment Disc

38999  
III  
II  
I  
SJT

26482  
Matrix 2

83723 III  
Matrix  
Pyle

5015  
Crimp Rear  
Release Matrix

26500 Pyle

Printed  
Circuit Board

EMI Filter  
Transient

Fiber Optics

High Speed  
Contacts

Options  
Others

38999  
SJT I II III

26482  
Matrix 2

83723 III  
Matrix Pyle

5015  
Crimp Rear  
Release Matrix

26500 Pyle

Printed  
Circuit Board

EMI Filter  
Transient

Fiber Optics

High Speed  
Contacts

Options  
Others

### PC TAIL COAX, TWINAX, AND TRIAX CONTACTS FOR USE IN D38999 SERIES I & III CONNECTORS

| Size      | PC Tail Coax Contact Part Number | PC Tail Twinax Contact Part Number | PC Tail Triax Contact Part Number | Tails*                     | Comments  |
|-----------|----------------------------------|------------------------------------|-----------------------------------|----------------------------|---|
| 8 Pin     | 21-33733-7                       |                                    |                                   | PCB 2 tails                |   |
| 8 Pin     | 21-33733-2                       |                                    |                                   | PCB 2 tails                | For epoxy filled connector                          |
| 8 Pin     | 21-33733-4                       |                                    |                                   | PCB 2 tails                | For epoxy filled connector                          |
| 8 Pin     | 21-33733-5                       |                                    |                                   | PCB 4 outer tails, 1 inner |   |
| 8 Pin     | 21-33733-9                       |                                    |                                   | PCB 2 tails                |   |
| 8 Pin     | 21-33733-8                       |                                    |                                   | PCB 2 tails                |   |
| 8 Socket  | 21-33426-1                       |                                    |                                   | PCB 2 tails                |   |
| 8 Pin     |                                  | 21-33967-115                       |                                   | PCB 3 tails                | M39029/90/91 Interface                              |
| 8 Pin     |                                  | 21-33967-125                       |                                   | PCB 3 tails                |   |
| 8 Pin     |                                  | 21-33967-15                        |                                   | PCB 3 tails                |   |
| 8 Pin     |                                  | 21-33967-45                        |                                   | PCB 3 tails                |   |
| 8 Pin     |                                  | 21-33967-55                        |                                   | PCB 3 tails                |   |
| 8 Pin     |                                  | 21-33967-65                        |                                   | PCB 3 tails                |   |
| 8 Pin     |                                  | 21-33967-85                        |                                   | PCB 3 tails                |   |
| 8 Pin     |                                  | 21-33967-95                        |                                   | PCB 3 tails                |   |
| 8 Pin     |                                  | P-209550†                          |                                   | PCB 3 tails                |   |
| 8 Pin     |                                  | P-209532-1                         |                                   | PCB 9 tails                |   |
| 8 Pin     |                                  | P-209532-2                         |                                   | PCB 9 tails                |   |
| 8 Socket  |                                  | 21-33921-15                        |                                   | PCB 3 tails                |   |
| 8 Socket  |                                  | 21-33921-45                        |                                   | PCB 3 tails                |   |
| 8 Socket  |                                  | 21-33921-35                        |                                   | PCB 3 tails                |   |
| 8 Socket  |                                  | 21-33921-65                        |                                   | PCB 3 tails                |   |
| 8 Socket  |                                  | 21-33921-75                        |                                   | PCB 3 tails                |   |
| 8 Socket  |                                  | 21-33921-115†                      |                                   | PCB 3 tails                |   |
| 8 Socket  |                                  | 21-33921-105†                      |                                   | PCB 3 tails                | M39029/90/91 Interface<br>.040 dia. tails           |
| 8 Socket  |                                  | DB-109002                          |                                   | PCB 2 tails                | M39029/91 Interface<br>Outer body grounded to shell |
| 8 Socket  |                                  | 21-33919-15                        |                                   | PCB 2 tails                |   |
| 8 Socket  |                                  | 21-33919-25                        |                                   | PCB 2 tails                |   |
| 8 Pin     |                                  |                                    | 21-33828-1                        | PCB 3 tails                |   |
| 8 Pin     |                                  |                                    | 21-33828-21                       | PCB 3 tails                |   |
| 8 Pin     |                                  |                                    | 21-33828-41                       | PCB 3 tails                |   |
| 8 Socket  |                                  |                                    | 21-33840-1                        | PCB 3 tails                |   |
| 8 Socket  |                                  |                                    | 21-33840-21                       | PCB 2 tails                | Outer body grounded to shell                        |
| 8 Socket  |                                  |                                    | 21-33841-1                        | PCB 2 tails                | Outer body grounded to shell                        |
| 10 Pin    |                                  | 21-33844-2†                        |                                   | PCB 2 tails                | Outer body grounded to shell                        |
| 12 Socket |                                  |                                    |                                   |                            |   |

\* Consult Amphenol Aerospace for tail configurations and tail diameters.  
† Consult Amphenol Aerospace for current release of this contact.

CONTACT ORDERING: Example number given in chart 21-33733-7 should be ordered as 21-033733-007; example number given in chart 21-33967-115 should be ordered as 21-033967-115; example number given in chart 21-33840-21 should be ordered as 21-033840-021. Adding Zeros is necessary for Amphenol ordering process on all contact numbers.

# Coax, Twinax & Triax PC Tail Contacts

## Application Data, cont.



| PC TAIL COAX, TWINAX, AND TRIAX CONTACTS FOR USE IN D38999 SERIES I & III CONNECTORS |                                  |                                    |                                   |                        |  |
|--|----------------------------------|------------------------------------|-----------------------------------|------------------------|--|
| Size   | PC Tail Coax Contact Part Number | PC Tail Twinax Contact Part Number | PC Tail Triax Contact Part Number | Tails*                 | Comments                               |
| 12 Pin   | 21-33686-8                       |                                    |                                   | PCB 2 tails            |  |
| 12 Pin   | 21-33686-9                       |                                    |                                   | PCB 2 tails            | Outer tail clip type                   |
| 12 Pin   | 21-33686-5                       |                                    |                                   | PCB 2 tails            |  |
| 12 Pin   | 21-33686-10                      |                                    |                                   | PCB 2 tails            |  |
| 12 Pin   | 21-33686-13                      |                                    |                                   | PCB 2 tails            | Outer tail clip type                   |
| 12 Pin   | 21-33687-6                       |                                    |                                   | PCB 2 tails            | For epoxy filled connector             |
| 12 Pin   | 21-33687-7                       |                                    |                                   | PCB 2 tails            |  |
| 12 Pin   | 21-33686-16†                     |                                    |                                   | PCB 2 tails            |  |
| 12 Socket  | 21-33614-1                       |                                    |                                   | PCB 2 tails            |  |
| 12 Socket  | 21-33614-21                      |                                    |                                   | PCB 2 tails            |  |
| 12 Socket  | 21-33614-41                      |                                    |                                   | PCB 2 tails            |  |
| 12 Socket  | 21-33611-3                       |                                    |                                   | PCB 2 tails            | Outer tail clip type                   |
| 12 Socket  | 21-33440-1                       |                                    |                                   | PCB 3 tails            |  |
| 12 Socket  | 21-33430-1                       |                                    |                                   | PCB 2 tails            | Outer tail clip type, M38999 Series II |
| 12 Socket  | 21-33430-21                      |                                    |                                   | PCB 2 tails            | M38999 Series II                       |
| 12 Socket  | 21-33430-41                      |                                    |                                   |                        | M38999 Series II                       |
| 12 Pin   |                                  | 21-33633-1†**                      |                                   | PCB 4 tails            | JN1104 Interface                       |
| 12 Pin   |                                  | 21-33633-2**                       |                                   | PCB 4 tails            |  |
| 12 Pin   |                                  | 21-33633-6**                       |                                   | PCB 4 tails            |  |
| 12 Pin   |                                  | 21-33633-7**                       |                                   | PCB 4 tails            |  |
| 12 Socket  |                                  | 21-33393-6**                       |                                   | PCB 4 tails            |  |
| 12 Socket  |                                  | 21-33393-5**                       |                                   | PCB 4 tails            |  |
| 12 Socket  |                                  | 21-33433-1**                       |                                   | PCB 4 tails            |  |
| 16 Pin   | 21-33856-15                      |                                    |                                   | PCB 2 tails            |  |
| 16 Pin   | 21-33856-25                      |                                    |                                   | PCB 90 degree, 2 tails |  |
| 16 Pin   | 21-33856-65                      |                                    |                                   | PCB 2 tails            |  |
| 16 Pin   | 21-33634-15                      |                                    |                                   | PCB 1 tail             | Outer body grounded to shell           |
| 16 Pin   | 21-33634-35                      |                                    |                                   | PCB 1 tail             | Outer body grounded to shell           |
| 16 Pin   | 21-33634-45                      |                                    |                                   | PCB 1 tail             |  |
| 16 Pin   | 21-33386-1                       |                                    |                                   | PCB 2 tails            |  |
| 16 Socket  | 21-33857-1                       |                                    |                                   | PCB 2 tails            |  |
| 16 Socket  | 21-33857-8                       |                                    |                                   | PCB 2 tails            |  |
| 16 Socket  | 21-33857-7                       |                                    |                                   | PCB 2 tails            |  |
| 16 Socket  | 21-33610-1                       |                                    |                                   | PCB 2 tails            |  |
| 16 Socket  | 21-33610-2                       |                                    |                                   | PCB 2 tails            |  |
| 16 Socket  | 21-33441-1                       |                                    |                                   | PCB 2 tails            |  |
| 16 Socket  | 21-33606-1                       |                                    |                                   | PCB 2 tails            |  |
| 16 Socket  | 21-33606-21†                     |                                    |                                   | PCB 2 tails            | M38999 Series II                       |
| 16 Socket  | 21-33606-31†                     |                                    |                                   | PCB 2 tails            |  |
| 16 Socket  | 21-33610-3                       |                                    |                                   | PCB 2 tails            |  |
| 16 Socket  | 21-33857-3                       |                                    |                                   | PCB 2 tails            |  |

\* Consult Amphenol Aerospace for tail configurations and tail diameters.

\*\* Size 12 twinax and triax contacts are interchangeable.

† Consult Amphenol Aerospace for current release of this contact.

CONTACT ORDERING: Example number given in chart 21-33633-7 should be ordered as 21-033633-007; example number given in chart 21-33686-10 should be ordered as 21-033686-010. Adding Zeros is necessary for Amphenol ordering process on all contact numbers.

III  
II  
I  
SJT  
38999

26482  
Matrix 2

83723 III  
Matrix  
Pyle

5015  
Crimp Rear  
Release Matrix

26500 Pyle

Printed  
Circuit Board

EMI Filter  
Transient

Fiber Optics

High Speed  
Contacts

Options  
Others



Front face of pin inserts illustrated



|                    |            |             |               |             |             |                |               |             |             |
|--------------------|------------|-------------|---------------|-------------|-------------|----------------|---------------|-------------|-------------|
| Insert Arrangement | <b>9-5</b> | <b>10-2</b> | <b>11-2</b>   | <b>12-3</b> | <b>13-3</b> | <b>12-4</b>    | <b>13-4</b>   | <b>14-4</b> | <b>15-4</b> |
| Connector Series   | <b>TV</b>  | <b>SJT</b>  | <b>LJT,TV</b> | <b>JT</b>   | <b>LJT</b>  | <b>JT, SJT</b> | <b>LJT,TV</b> | <b>JT</b>   | <b>LJT</b>  |
| Service Rating     | Grounded   | I           |               | II          |             |                | I             |             | I           |
| Number of Contact  | 1          | 2           |               | 3           |             | 4              |               | 4           |             |
| Contact Size       | 8 Twinax   | 16          |               | 16          |             | 16             |               | 12          |             |

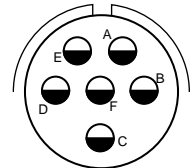
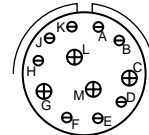
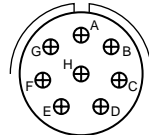
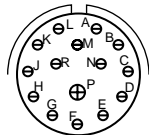
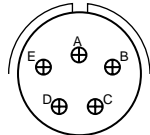

|                               |                |               |                |               |              |              |                |               |                |               |
|-------------------------------|----------------|---------------|----------------|---------------|--------------|--------------|----------------|---------------|----------------|---------------|
| Insert Arrangement            | <b>14-5</b>    | <b>15-5</b>   | <b>14-15</b>   | <b>15-15</b>  | <b>14-68</b> | <b>15-68</b> | <b>14-97</b>   | <b>15-97</b>  | <b>16-6</b>    | <b>17-6</b>   |
| Available in Connector Series | <b>JT, SJT</b> | <b>LJT,TV</b> | <b>JT, SJT</b> | <b>LJT,TV</b> | <b>JT</b>    | <b>LJT</b>   | <b>JT, SJT</b> | <b>LJT,TV</b> | <b>JT, SJT</b> | <b>LJT,TV</b> |
| Service Rating                | II             |               | I              |               | I            |              | I              |               | I              |               |
| Number of Contact             | 5              |               | 14             | 1             | 8            |              | 8              | 4             | 6              |               |
| Contact Size                  | 16             |               | 20             | 16            | 16           |              | 20             | 16            | 12             |               |

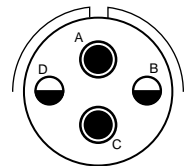
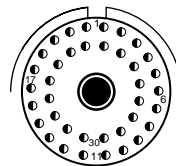
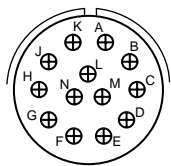
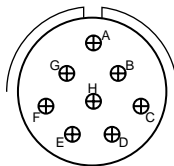

|                    |                |               |                |              |                |               |             |              |             |             |
|--------------------|----------------|---------------|----------------|--------------|----------------|---------------|-------------|--------------|-------------|-------------|
| Insert Arrangement | <b>16-8</b>    | <b>17-8</b>   | <b>16-13</b>   | <b>17-13</b> | <b>16-99</b>   | <b>17-99</b>  | <b>17-2</b> | <b>17-22</b> | <b>16-6</b> | <b>17-6</b> |
| Connector Series   | <b>JT, SJT</b> | <b>LJT,TV</b> | <b>JT, SJT</b> | <b>LJT</b>   | <b>JT, SJT</b> | <b>LJT,TV</b> | <b>LJT</b>  | <b>TV</b>    | <b>LJT</b>  | <b>TV</b>   |
| Service Rating     | II             |               | I              |              | I              |               | M           |              | Coax        |             |
| Number of Contact  | 8              |               | 13             |              | 21             | 2             | 38          | 1            | 2           | 2           |
| Contact Size       | 16             |               | 16             |              | 20             | 16            | 22D         | 8            | 12          | 8           |

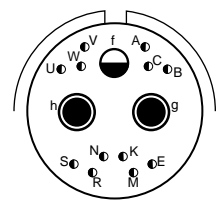
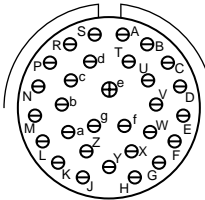
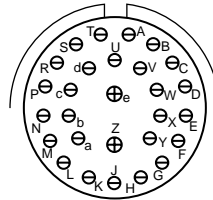
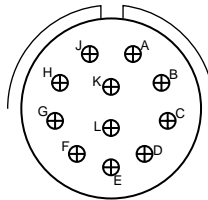
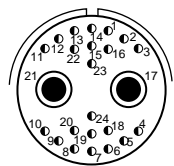

|                    |              |                |               |              |              |              |              |              |    |     |
|--------------------|--------------|----------------|---------------|--------------|--------------|--------------|--------------|--------------|----|-----|
| Insert Arrangement | <b>17-25</b> | <b>18-11</b>   | <b>19-11</b>  | <b>18-28</b> | <b>19-28</b> | <b>18-30</b> | <b>19-30</b> | <b>19-31</b> |    |     |
| Connector Series   | <b>LJT</b>   | <b>JT, SJT</b> | <b>LJT,TV</b> | <b>JT</b>    | <b>LJT</b>   | <b>JT</b>    | <b>LJT</b>   | <b>TV</b>    |    |     |
| Service Rating     | M            |                | II            |              | I            |              | I            | M            |    |     |
| Number of Contact  | 22           | 2              | 11            | 26           | 2            | 29           | 1            | 2            | 1  | 12  |
| Contact Size       | 22D          | 8              | 16            | 20           | 16           | 20           | 16           | 8            | 12 | 22D |

The insert arrangements shown on this page and the next page represent the most readily available patterns within the 38999 Circular Series. If you require other arrangements than what are shown here, consult Amphenol for further availability. In most cases, unless otherwise stated, size 8 and size 12 cavities can be filled with either coax, twinax, triax or power contacts.

### CONTACT LEGEND

|                            |                        |                            |               |       |       |
|----------------------------|------------------------|----------------------------|---------------|-------|-------|
|                            |                        |                            |               |       |       |
| 8                          | 10                     | 12                         | 16            | 20    | 22D   |
| Coax/Twinax/Triax or Power | Twinax/Triax/ or Power | Coax/Twinax/Triax or Power | Coax or Power | Power | Power |



# Insert Patterns - MIL-DTL-38999

## Incorporating Coax, Twinax and Triax Contacts



Front face of pin inserts illustrated

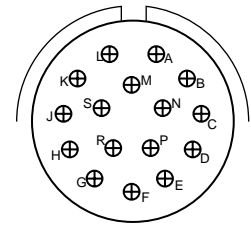
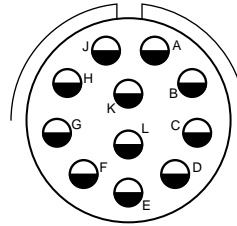
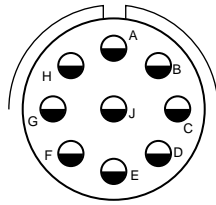
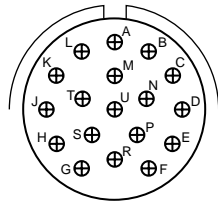

| Insert Arrangement | 18-68 | 19-68 | 18-96 | 20-11   | 21-11   | 20-16   | 21-16   |
|--------------------|-------|-------|-------|---------|---------|---------|---------|
| Connector Series   | JT    | LJT   | JT    | JT, SJT | LJT, TV | JT, SJT | LJT, TV |
| Service Rating     |       | I     | I     |         | I       |         | II      |
| Number of Contact  |       | 18    | 9     |         | 11      |         | 16      |
| Contact Size       |       | 16    | 12    |         | 12      |         | 16      |

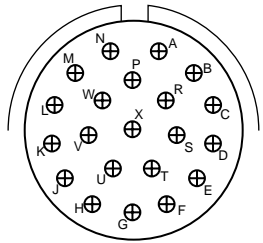
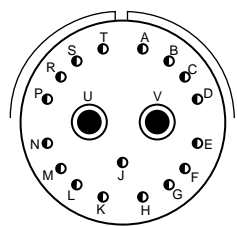
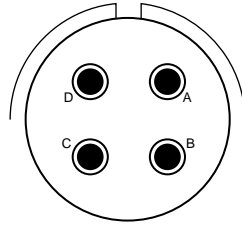
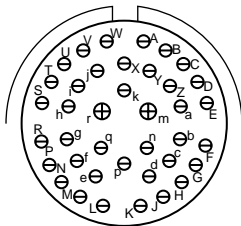

| Insert Arrangement | 20-39   | 21-39   | 20-75 | 21-75   | 20-79 | 21-79 | 22-21   | 23-21   |
|--------------------|---------|---------|-------|---------|-------|-------|---------|---------|
| Connector Series   | JT, SJT | LJT, TV | SJT   | LJT, TV | SJT   | LJT   | JT, SJT | LJT, TV |
| Service Rating     |         | I       |       | M       |       | II    |         | II      |
| Number of Contact  | 37      | 2       |       | 4       |       | 17    |         | 21      |
| Contact Size       | 20      | 16      |       | 8       |       | 22D   |         | 16      |

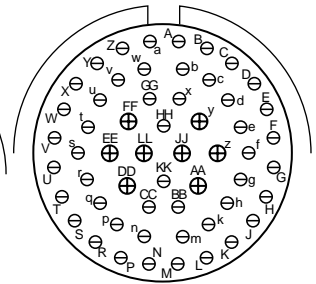
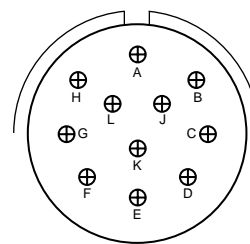
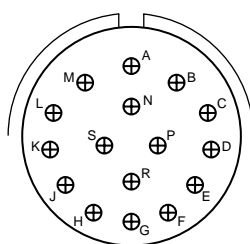
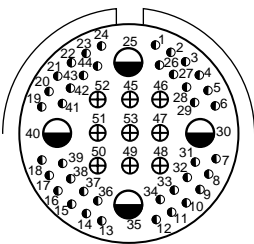

| Insert Arrangement | 23-54 | 23-97 | 23-99 | 24-4    | 25-4    |
|--------------------|-------|-------|-------|---------|---------|
| Connector Series   | TV    | LJT   | LJT   | JT, SJT | LJT, TV |
| Service Rating     |       | M     |       | II      | I       |
| Number of Contact  | 40    | 9     | 4     | 48      | 8       |
| Contact Size       | 22D   | 16    | 12    | 20      | 16      |

### CONTACT LEGEND

|                            |                        |                            |               |       |       |
|----------------------------|------------------------|----------------------------|---------------|-------|-------|
|                            |                        |                            |               |       |       |
| 8                          | 10                     | 12                         | 16            | 20    | 22D   |
| Coax/Twinax/Triax or Power | Twinax/Triax/ or Power | Coax/Twinax/Triax or Power | Coax or Power | Power | Power |

38999  
SJT

26482  
Matrix 2

83723  
Matrix Pyle

5015  
Crimp Rear Release Matrix

26500  
Pyle

Printed  
Circuit Board

EML Filter  
Transient

Fiber Optics

High Speed  
Contacts

Options  
Others

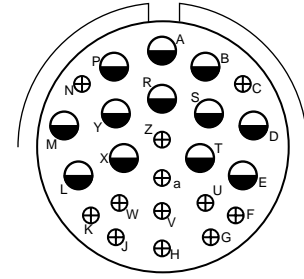
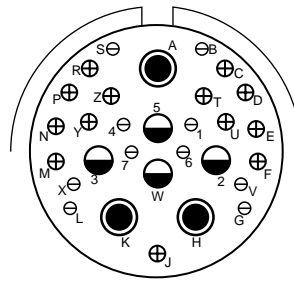
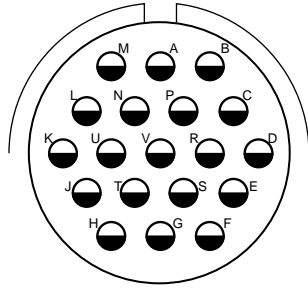

| Insert Arrangement | 24-19   | 25-19   | 24-20 | 25-20*  | 24-24   | 25-24   |
|--------------------|---------|---------|-------|---------|---------|---------|
| Connector Series   | JT, SJT | LJT, TV | SJT   | LJT, TV | JT, SJT | LJT, TV |
| Service Rating     | I       |         | N     |         | I       |         |
| Number of Contact  | 19      |         | 10    | 3       | 12      | 12      |
| Contact Size       | 12      |         | 20    | 8       | 16      | 12      |

(Locations U and Y - Dedicated to Fiber Optics)

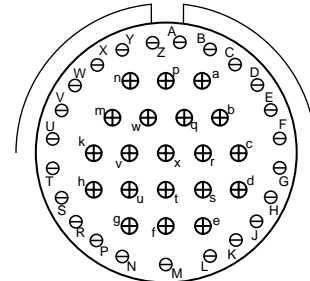
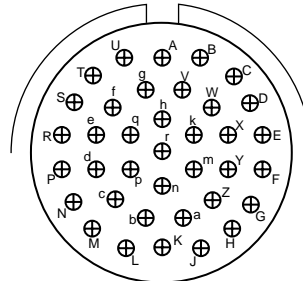
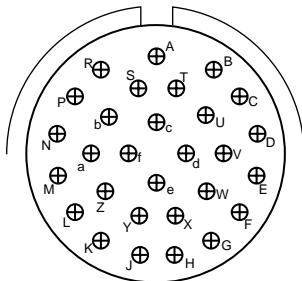

| Insert Arrangement | 24-29   | 25-29   | 24-37   | 25-37   | 24-43   | 25-43   |
|--------------------|---------|---------|---------|---------|---------|---------|
| Connector Series   | JT, SJT | LJT, TV | JT, SJT | LJT, TV | JT, SJT | LJT, TV |
| Service Rating     | I       |         | I       |         | I       |         |
| Number of Contact  | 29      |         | 37      |         | 23      | 20      |
| Contact Size       | 16      |         | 16      |         | 20      | 16      |

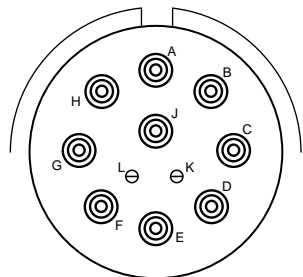
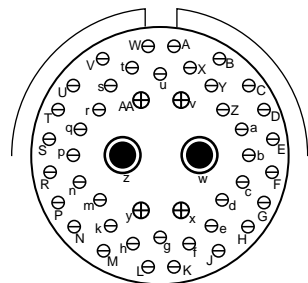

| Insert Arrangement | 24-46 | 25-46   | 25-11*  |
|--------------------|-------|---------|---------|
| Connector Series   | SJT   | LJT, TV | LJT, TV |
| Service Rating     | I     |         | N       |
| Number of Contact  | 40    | 4       | 2       |
| Contact Size       | 20    | 16      | 8       |

\* For use in MIL-STD-1760 applications with MIL-DTL-38999 Series III.

### CONTACT LEGEND

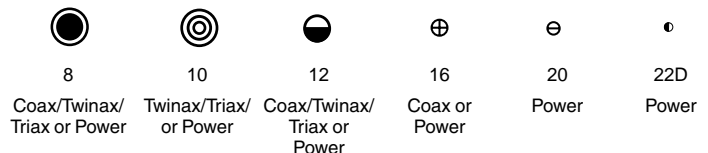

38999  
SJT I II III

26482  
Matrix 2

83723 III  
Matrix Pyle

5015  
Crimp Rear  
Release Matrix

26500 Pyle

Printed  
Circuit Board

EMI Filter  
Transient

Fiber Optics

High Speed  
Contacts

Options  
Others

# MIL-DTL-5015, MIL-DTL-22992 Circular Connector Overview



Amphenol's medium to heavy weight circular include the MS/Standard MIL-DTL-5015 series and the heaviest weight, largest size circular is the Heavy Duty MIL-DTL-22992 series. These time-tested circulars have been used for several years. They are dependable general duty and environmentally resistant connectors for military and industrial applications.

Shielded coax contacts, although more popularly used in 38999 types and 26482 types, can be incorporated into some arrangements of the 5015 and 22992 type circulars. Shielded coaxial contacts within these series are considered MS modifications to the MIL-spec connector and the coax contacts are pre-installed in the connector. Normal operating voltage with power contacts only is up to 3000 VAC (RMS) at sea level for MIL-DTL-5015 circulars. The Heavy Duty types are designed for high current capacity and have current ratings (with power contacts only) of up to 200 amps.

## Standard and Heavy Duty Circular offer these features for contact termination flexibility:

- Insert arrangements that can incorporate:
- Size 4, 8 & 12 Crimp Coax contacts, pre-installed in the connector
- Wide selection of connector shell styles and sizes
- Standard power contact options within the various connector styles include: solder type, crimp front release, crimp rear release
- Coax contacts are designed to the same high performance standards as power contacts. Coax and power contacts may be intermixed with no degradation of connector reliability.

## Amphenol® MS/Standard Circular MIL-DTL-5015\* Type Connector Family:

See MS/Standard catalog 12-020 for complete information on these styles

### MS-A, MS-C, MS-E, MS-F, MS-R

- Produced in strict accordance with MIL-DTL-5015
- Threaded coupling, solder or crimp rear insertion contacts (coax available in crimp type only)
- Class A, Solid Shell - intended for general connector usage
- Class C, Pressurized - for use on pressurized bulkheads or pressure barriers
- Class E/F, Environmental Resisting - ideally suited for installation where condensation, vibration and rapid changes in pressure or temperature are considerations
- Class R, Lightweight Environmental Resisting - shorter in length and lighter in weight than Class E

## GENERAL ORDERING INFORMATION

Amphenol MS/Standard MIL-DTL-5015 type and Heavy Duty MIL-DTL-22992 type circulars are normally supplied with a full complement of power contacts, separately packaged. Coax contacts are ordered by part number as referenced in the part number charts on the following pages of this catalog, and are substituted for the power contacts at the time of the cable or equipment assembly. Coax contacts are pre-installed in these series. Installation instructions for the coax contacts for these series are provided in Amphenol document L-650.

### HOW TO ORDER:

1. Select the coax contacts designed for the cable being used from the chart on page 409 of this catalog. Select a connector insert from those shown on page 44 which will accommodate the quantity and size of coaxial contacts needed plus any power contacts required.
2. Determine the MS/Standard or Heavy Duty Series style desired. (See features of each series referenced above). The catalog referenced for each series will guide you in determining shell style, finish, service class and insert rotation required for your application. MS/Standard MIL-DTL-5015 Type Connectors (Catalog 12-020 on-line at [www.amphenol-industrial.com](http://www.amphenol-industrial.com)) Catalog 12-052 - MIL-DTL-22992 QWLD Connectors (on-line at [www.amphenol-aerospace.com](http://www.amphenol-aerospace.com)) Catalog 12-053 - QWL Connectors (currently not on-line; consult Amphenol Aerospace for hardcopy)
3. Consult Amphenol, Sidney, NY with the pertinent cable, contact, insert arrangement and connector style choices for complete connector part number.

\* Amphenol also offers the following other MIL-DTL-5015 Circular Connectors which are threaded coupling

(consult Amphenol Industrial for availability of shielded contacts in any of these series):

- Amphenol®/Matrix® MIL-DTL-5015 with crimp rear releasable and rear insertable contacts. (See Matrix 5015 section of this catalog)
- Amphenol® MIL-DTL-5015 Modifications (Ask for Industrial Catalog 12-021)
- Amphenol® GT Series with reverse bayonet coupling (Ask for Catalog 12-024)
- Amphenol® AC Threaded and AC-B Bayonet Series (Ask for Industrial Catalog 12-025)

### NOTE:

MIL-DTL-5015 supersedes MIL-C-5015  
MIL-DTL-22992 supersedes MIL-C-22992



MS/Standard MIL-DTL-5015 Type Connectors



Heavy Duty QWLD, MIL-DTL-22992 Connectors

38999  
SJT

26482  
Matrix 2

83723 III  
Pyle

5015  
Crimp Rear Release Matrix

26500 Pyle

Printed  
Circuit Board

EMI Filter  
Transient

Fiber Optics

High Speed  
Contacts

Options  
Others

38999  
SJT I II III

26482  
Matrix 2

83723 III  
Matrix Pyle

5015  
Crimp Rear  
Release Matrix

26500 Pyle

Printed  
Circuit Board

EMI Filter  
Transient

Fiber Optics

High Speed  
Contacts

Options  
Others

**Amphenol® Coaxial Contacts** can be incorporated into MS/Standard MIL-DTL-5015 Type Circular Connectors and Heavy Duty MIL-DTL-22992 Connectors. They offer the same durability advantages and design benefits for reliable interconnection as the Amphenol coax contacts used in high performance D38999 connectors. A variety of military and commercial shielded cables are accommodated within these circular series.

Other features of the coax contacts available for MS/Standard and Heavy Duty circulars include:

- Several insert arrangements that can incorporate:
  - Size 4, 8 and 12 coax contacts
- Advanced shielding wire technology in a rugged military connector
- Single connector with multiple coaxial connection eliminates cross-mating
- Positive contact captivation - especially important in these series with its much higher coupling/uncoupling force
- Older shielded cable type availability



**Coax Contact, Pin**  
for use in MS/Standard MIL-DTL-5015 and  
Heavy Duty MIL-DTL-22992 Connectors



**Coax Contact, Socket**  
for use in MS/Standard MIL-DTL-5015 and  
Heavy Duty MIL-DTL-22992 Connectors

**TYPICAL ELECTRICAL PERFORMANCE**

Size 4, 8 & 12 Contacts  
 Contact Resistance:  
 Center @ 1 Amp, 170 millivolts max. voltage drop @ 25°C  
 Outer @ 12 Amps, 150 millivolts max. voltage drop @ 25°C  
 Dielectric Withstanding Voltage:  
 Size 4 & 8: 1,300 VAC Rms @ sea level  
 Size 12: 1,000 VAC Rms @ sea level  
 Size 4, 8 & 12: 250 VAC Rms @ 50,000 ft.  
 Insulation Resistance  
 5,000 megohms minimum @ 25°C

All contacts in these series are non-impedance matched contacts.

Part numbers 21-33063-XX( ) and 21-33064-XX( ) are moisture seal design (internal O-ring).

**CONTACT FINISHES:**

| Suffix | Finish   |
|--------|--|
| 1      | 0.00020 min. silver over copper flash                  |
| 2      | 0.00005 min. gold (Knoop hardness 130-200) over silver |
| 3      | 0.00010 min. gold (Knoop hardness 130-200) over silver |
| 4      | 0.00010 min. gold (Knoop hardness 130-200) over copper |
| 5      | 0.00005 min. gold (Knoop hardness 130-200) over nickel |
| E      | 0.00005 min. gold (Knoop hardness 90 max.) over copper |
| F      | 0.00005 min. gold (Knoop hardness 130-200) over copper |
| H      | 0.00010 min. gold (Knoop hardness 130-200) over copper |

# Coaxial Contacts for MIL-DTL-5015, Heavy Duty MIL-DTL-22992 Application Data

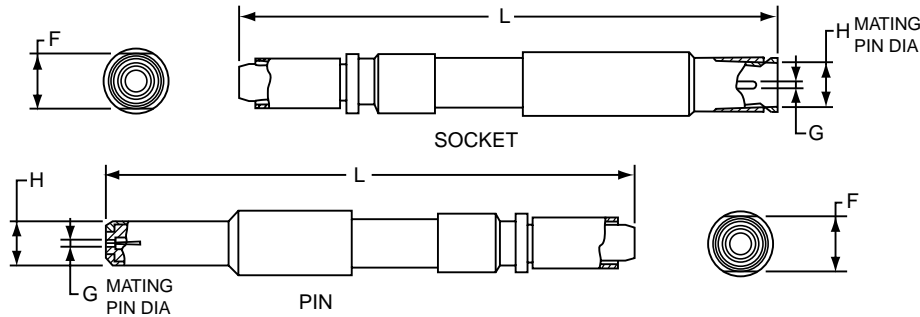

NOTE: All contacts of the same size and the same inner and outer contact diameters (G & H) will mate with each other.

| COAX CONTACTS   |  |                |              |                                     |  |                |                        |               |                     |   |   |                     |  |
|---|--|----------------|--------------|-------------------------------------|--|----------------|------------------------|---------------|---------------------|---|---|---------------------|--|
| For use in MS/Standard MIL-DTL-5015 Type and Heavy Duty MIL-DTL-22992 Type Connectors |  |                |              |                                     |  |                |                        |               |                     |   |   |                     |  |
| Cable   | Contact Part Number<br>(See L-650 Termination Instruction Sheet for all contacts listed below)** |                | Contact Size | Finish on Mating Parts (See Pg. 42) | Dimensional Data<br>(See Drawings above) |                |                        |               | Crimp Ferrule Tools |   |   | Retainer Nut Wrench |  |
|   | Pin  | Socket         |              |                                     | G Dia.                                   | H Dia. ± 0.001 | F Across Flats ± 0.004 | L Length Ref. |                     | MIL-T-22910/7-1 Tool Use with Die Part Number | MIL-T-22520/5-01 Tool Use with Die Part Number        |                     | MIL-T-229520/10-01 Tool Use with Die Part Number |
| RG-58C/U,<br>RG-141A/U,<br>RG-303/U   | 21-33014-1   | 21-33013-1     | 8            | 5                                   | 0.0355<br>± 0.0010                       | 0.218          | 0.280                  | 1.481         | 1.511               | M22910/7-15 (B)                               | M22520/5-05 (B)<br>M22520/5-41 (B)                    | M22520/10-07 (B)    | 11-8676-2  |
|   | 21-33034-2   | 21-33033-2     | 8            | 1                                   |  |                |                        |               |                     |   |   |                     |  |
|   | 21-33048-2   | 21-33047-2     | 8            | ††                                  |  |                |                        |               |                     |   |   |                     |  |
|   | 21-33016-5   | 21-33015-5     | 8            | 3                                   |  |                |                        |               |                     |   |   |                     |  |
|   | 21-33130-2()   | 21-33129-2()   | 8            | ***                                 |  |                |                        |               |                     |   |   |                     |  |
| RG-59B/U,<br>RG-62A/U,<br>RG-62B/U,<br>RG-210/U                                       | 21-33014-5   | 21-33013-5     | 8            | 5                                   | 0.0355<br>± 0.0010                       | 0.218          | 0.280                  | 1.481         | 1.511               | M22910/7-18 (B)                               | M22520/5-45 (B)                                       |                     | 11-8676-3  |
|   | 21-33016-2   | 21-33015-2     | 8            | 3                                   |  |                |                        |               |                     |   |   |                     |  |
|   | 21-33034-5   | 21-33033-5†    | 8            | 1                                   |  |                |                        |               |                     |   |   |                     |  |
|   | 21-33130-5()   | 21-33129-5()   | 8            | ***                                 |  |                |                        |               |                     |   |   |                     |  |
|   | 21-33064-21()  | 21-33063-21()  | 8            | ***                                 |  |                |                        |               |                     |   |   |                     |  |
| 21-33060-10()   | 21-33059-10()  | 4              | ***          | 0.0400<br>± 0.0010                  | 0.344                                    | 0.375          | 1.669                  | 1.605         |                     |   |   | 11-8676-4           |  |
| RG-161/U,<br>RG-174A/U,<br>RG-179B/U,<br>RG-187A/U,<br>RG-188A/U,<br>RG-316/U         | 21-33014-3   | 21-33013-3     | 8            | 5                                   | 0.0355<br>± 0.0010                       | 0.218          | 0.280                  | 1.481         | 1.511               | M22910/7-12 (B)                               | M22520/5-03 (A)<br>M22520/5-08 (A)<br>M22520/5-35 (B) | M22520/10-05 (A)    | 11-8676-2  |
|   | 21-33016-1   | 21-33015-1     | 8            | 3                                   |  |                |                        |               |                     |   |   |                     |  |
|   | 21-33034-3   | 21-33033-3     | 8            | 1                                   |  |                |                        |               |                     |   |   |                     |  |
|   | 21-33130-3()†  | 21-33129-3()†  | 8            | ***                                 |  |                |                        |               |                     |   |   |                     |  |
|   | 21-33064-20()†   | 21-33063-20()† | 8            | ***                                 |  |                |                        |               |                     |   |   |                     |  |
| 21-33014-21   | 21-33013-21  | 12             | 5            | 0.0200<br>± 0.0005                  | 0.128                                    | 0.172          |                        |               |                     |   |   | 11-8676-1           |  |
| 21-33034-1  | 21-33033-1   | 12             | 1            |                                     |  |                |                        |               |                     |   |   |                     |  |
| 21-33048-1  | 21-33047-1   | 12             | ***          |                                     |  |                |                        |               |                     |   |   |                     |  |
| 21-33130-1()†   | 21-33129-1()†  | 12             | ***          |                                     |  |                |                        |               |                     |   |   |                     |  |
| RG-178B/U,<br>RG-196A/U   | 21-33014-22†   | 21-33013-22†   | 12           | 5                                   | 0.0200<br>± 0.0005                       | 0.128          | 0.172                  | 1.481         | 1.511               | M22910/7-11 (B)                               | M22520/5-03 (B)<br>M22520/5-33 (B)                    | M22520/10-05 (B)    | 11-8676-1  |
| RG-180B/U,<br>RG-195A/U   | 21-33014-6   | 21-33013-6     | 8            | 5                                   | 0.355<br>± 0.0010                        | 0.218          | 0.280                  | 1.481         | 1.511               | M22910/7-15 (B)                               | M22520/5-05 (B)<br>M22520/5-41 (B)                    | M22520/10-07 (B)    | 11-8676-2  |
|   | 21-33034-6†  | 21-33033-6†    | 8            | 1                                   |  |                |                        |               |                     |   |   |                     |  |
|   | 21-33048-3   | 21-33047-3     | 8            | ***                                 |  |                |                        |               |                     |   |   |                     |  |
|   | 21-33130-6()†  | 21-33129-6()   | 8            | ***                                 |  |                |                        |               |                     |   |   |                     |  |
| RG-212/U  | 21-33060-11()  | 21-33059-11()  | 4            | ***                                 | 0.0625<br>± 0.0010                       | 0.344          | 0.375                  | 1.669         | 1.605               | M22910/7-14 (A)                               | M22520/5-39 (A)                                       |                     | 11-8676-4  |
| RG-140/U,<br>RG-302/U   | 21-33014-8   | 21-33013-8     | 8            | 5                                   | 0.0355<br>± 0.0010                       | 0.218          | 0.280                  | 1.481         | 1.511               | M22910/7-17 (B)                               | M22520/5-05 (A)<br>M22520/5-19 (B)                    | M22520/10-07 (A)    | 11-8676-2  |
|   | 21-33034-8   | 21-33033-8     | 8            | 1                                   |  |                |                        |               |                     |   |   |                     |  |
|   | 21-33130-8()†  | 21-33129-8()†  | 8            | ***                                 |  |                |                        |               |                     |   |   |                     |  |
| RG-55B/U,<br>RG-142A/U,<br>RG-142B/U,<br>RG-223/U                                     | 21-33014-4   | 21-33013-4     | 8            | 5                                   | 0.0355<br>± 0.0010                       | 0.218          | 0.280                  | 1.481         | 1.511               | M22910/7-17 (B)                               | M22520/5-05 (A)<br>M22520/5-19 (B)                    | M22520/10-07 (A)    | 11-8676-2  |
|   | 21-33034-4   | 21-33033-4     | 8            | 1                                   |  |                |                        |               |                     |   |   |                     |  |
|   | 21-33130-4()   | 21-33129-4()   | 8            | ***                                 |  |                |                        |               |                     |   |   |                     |  |
|   | 21-33060-12()  | 21-33059-12()  | 4            | ***                                 |  |                |                        |               |                     |   |   |                     |  |

CONTACT ORDERING: Example number given in chart 21-33014-1 should be ordered as 21-033014-001; example number 21-33014-21 should be ordered as 21-033014-021. Adding Zeros is necessary for Amphenol ordering process on all contact numbers. \*\*\*See finish options for MS/Standard and Heavy Duty contacts listed on page 408. Replace the parenthesis of the contact part number with the finish suffix number. However, you should consult Amphenol Aerospace regarding the availability of all finish choices for each part number.

† Consult Amphenol Aerospace for current availability of this contact. CRIMPING TOOLS: Italicized letters in parenthesis that follow positioner part numbers indicate applicable die closure. Commercial equivalents with the same die closure dimension may be used. †† 21-33047-X and 21-33048-X are supplied with E (soft gold) finish on mating socket parts, and F (hard gold) finish on mating pin parts.

\*\*Termination instruction sheet L-650 can be found on-line at: [www.amphenol-aerospace.com/serviceinstructions.asp](http://www.amphenol-aerospace.com/serviceinstructions.asp)

38999  
II  
I  
SJT

26482  
Matrix 2

83723 III  
Matrix  
Pyle

5015  
Crimp Rear  
Release Matrix

26500 Pyle

Printed  
Circuit Board

EMI Filter  
Transient

Fiber Optics

High Speed  
Contacts

Options  
Others



### Incorporating Coax Contacts

Front face of pin inserts illustrated

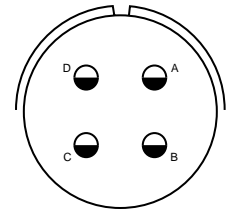
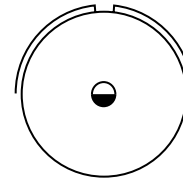
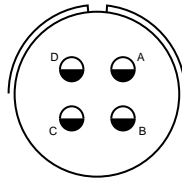
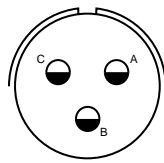

| Insert Arrangement | 16-10                  | 18-10                  | 18-16                  | 20-4                   |
|--------------------|------------------------|------------------------|------------------------|------------------------|
| Connector Series   | MS/Standard, QWLD, QWL | MS/Standard, QWLD, QWL | MS/Standard, QWLD, QWL | MS/Standard, QWLD, QWL |
| Service Rating     | A                      | A                      | C                      | D                      |
| Number of Contact  | 3                      | 4                      | 1                      | 4                      |
| Contact Size       | 12                     | 12                     | 12                     | 12                     |

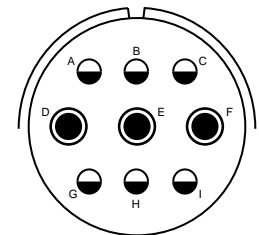
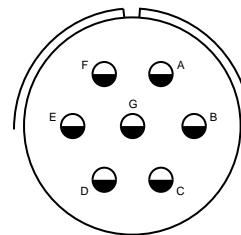
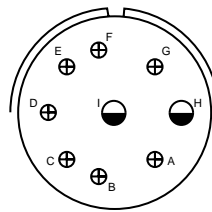
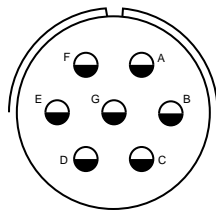

| Insert Arrangement | 20-15                  | 20-16                  | 24-2                   | 24-11                  |
|--------------------|------------------------|------------------------|------------------------|------------------------|
| Connector Series   | MS/Standard, QWLD, QWL | MS/Standard, QWLD, QWL | MS/Standard, QWLD, QWL | MS/Standard, QWLD, QWL |
| Service Rating     | A                      | A                      | D                      | A                      |
| Number of Contact  | 7                      | 2      7               | 7                      | 3      6               |
| Contact Size       | 12                     | 12      16             | 12                     | 8      12              |

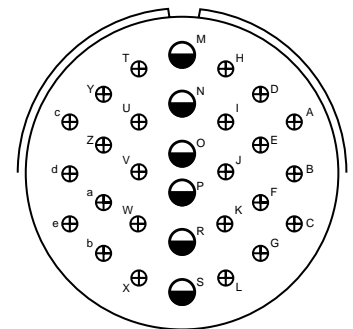
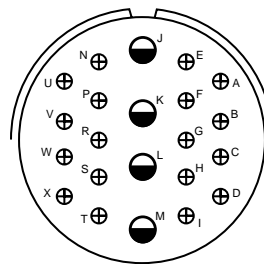
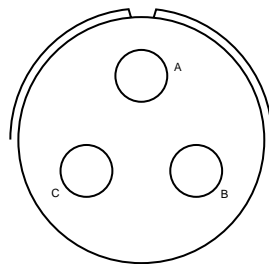

| Insert Arrangement | 28-6                   | 28-11                  | 32-8                   |
|--------------------|------------------------|------------------------|------------------------|
| Connector Series   | MS/Standard, QWLD, QWL | MS/Standard, QWLD, QWL | MS/Standard, QWLD, QWL |
| Service Rating     | D                      | A                      | A                      |
| Number of Contact  | 3                      | 4      18              | 6      24              |
| Contact Size       | 4                      | 12      16             | 12      16             |

The insert arrangements shown on this page represent the most readily available patterns within the MIL-DTL-5015 and MIL-DTL-22992 Series. If you require other arrangements than what are shown here, consult Amphenol for further availability. MS/Standard connectors have over 200 insert pattern arrangements available, and within these patterns any size 4, 8 or 12 contact cavities can be incorporated with coax contacts. However, you need to consult Amphenol, Sidney NY for availability and ordering information. All coax contacts in the Standard and Heavy Duty series come pre-installed in connectors.

#### CONTACT LEGEND

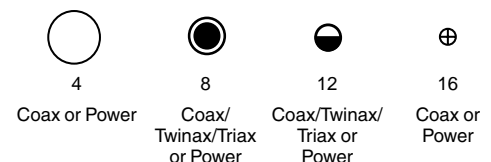



# Rectangular Rack & Panel Connectors

## That Incorporate High Speed Contacts

Amphenol provides an impressive array of Rectangular Interconnection products to meet the needs of high density systems such as opto-electrical backplanes used in many applications that include: medical equipment, IC chip testers, telecommunications, military and commercial aviation, military ground vehicles, GPS systems, space and industrial applications.

- ARINC 600 and R27 Rack and Panel connectors can incorporate:
  - size 8 Coax contacts
  - Size 1 and size 5 Coax (consult Amphenol Canada)
  - Size 12 Twinax contacts
  - Size 8 Quadrax contacts
  - Size 8 Differential Twinax contacts

### ARINC 600 Rack and Panel Rectangular Connectors

See Amphenol Canada Publication SL-379, ARINC 600 Rack and Panel Connectors for complete information.

- The ARINC 600 is the successor to the ARINC 404 for many of the new avionics designs and offers lower mating force contacts, increased contact count and a front release, floating keying system
- ARINC 600 Connectors are a recognized standard rack and panel connector for aircraft applications with both environmental and non-environmental versions available
- Designed to meet all relevant ARINC 600 connector specifications
- Front removable keying posts
- Up to 800 size 22 contact positions in one connector
- Contact options: standard contacts are power/signal crimp rear release in sizes 12, 16, 20 and 22 in crimp or PCB; or shielded coax, concentric twinax, quadrax contacts; or fiber optics
- Waveguide connections

### R27 Rack and Panel Rectangular Connectors

See Amphenol Canada Publication for R27 Series Connectors for complete information.

- The R27 Series is a robust rectangular connector designed to meet or surpass all the requirements of the MIL-DTL-83527 specification and EN 3682 European Standard.
- Well suited for harsh environments - enhanced environmental sealing, robust and durable shells, EMI shielding spring
- Filtered or non-filtered
- Connectors, shells, inserts, termination modules and contacts are sold separately or fully assembled
- Interchangeable insert patterns with ARINC 600 models
- Contact options: standard contacts are power/signal crimp rear release in sizes 12, 16, 20 and 22 in crimp or PCB; or shielded coax, concentric twinax, quadrax contacts; or fiber optics



ARINC 600 Rack and Panel Connectors are high density connectors that can incorporate high speed shielded contacts



R27 Series Rack and Panel Connector can incorporate high speed shielded contacts



Coax Contact , Size 8 for use in ARINC Rack and Panel Connectors

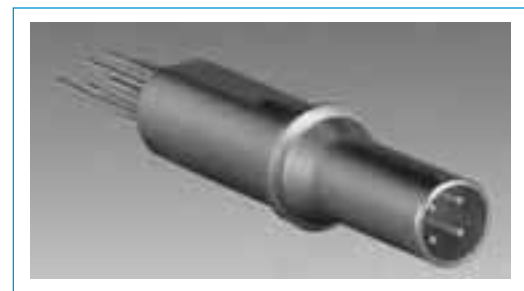

Quadrax Contact , Size 8 for use in ARINC Rack and Panel Connectors

38999  
SJT

26482  
Matrix 2

83723 III  
Pyle

5015  
Crimp Rear Release Matrix

26500 Pyle

Printed  
Circuit Board

EMI Filter  
Transient

Fiber Optics

High Speed  
Contacts

Options  
Others

38999  
SJT I II III

26482  
Matrix 2

83723 III  
Matrix Pyle

5015  
Crimp Rear Release Matrix

26500 Pyle

Printed  
Circuit Board

EMI Filter  
Transient

Fiber Optics

High Speed  
Contacts

Options  
Others

### ARINC 600 & R27 Rack and Panel Connectors

| QUADRAX CONTACTS<br>FOR USE IN ARINC 600 & R27 CONNECTORS                    |  |                              |                     |                 |   |   |
|--|--|------------------------------|---------------------|-----------------|---|---|
| Cable  | Contact Part Number<br>(Termination Instruction Sheet)** |                              | Impedance<br>(Ohms) | Contact<br>Size | Crimping Tools  |   |
|  | Pin  | Socket                       |                     |                 | Inner<br>Contact  | Outer Contact   |
| Tensolite NF24Q100,<br>24443/9P025X-4(LD),<br>S280W502-4, 24443/03130X-4(LD) | 21-33382-21<br>(L-2119-AH)                               | 21-33383-21<br>(L-2119-AH)   | 100                 | 8               | M22520/2-01<br>with Positioner Daniels<br>K709<br>(M22520/2-37) | M22520/5-01<br>with Die Set M22520/5-<br>45<br>(Location B) |
| Draka Fileca F-4703-3  | 21-33382-31<br>(L-2119-I)                                | 21-33383-31<br>(L-2119-I)    | 100                 |                 |   |   |
| Draka Fileca F-4704-5, NF22Q100  | 21-33382-101<br>(L-2119-AS)†                             | 21-33383-101<br>(L-2119-AS)† | 100                 |                 |   |   |
| JSFY02-1   | 21-33382-71<br>↑   | 21-33383-71<br>↑             | 110                 |                 |   |   |
| Tensolite 26473/02006X-4(LD),<br>Gore RCN8328                                | 21-33382-61<br>(L-2119-L)                                | 21-33383-61<br>(L-2119-L)    | 150                 |                 | M22520/2-01<br>with Positioner Daniels<br>K709<br>(M22520/2-37) | M22520/5-01<br>with Die Set M22520/5-<br>45<br>(Location A) |

| DIFFERENTIAL TWINAX CONTACTS<br>FOR USE IN ARINC 600 & R27 CONNECTORS |  |                            |                     |                 |   |   |
|---|--|----------------------------|---------------------|-----------------|---|---|
| Cable   | Contact Part Number<br>(Termination Instruction Sheet)** |                            | Impedance<br>(Ohms) | Contact<br>Size | Crimping Tools  |   |
|   | Pin  | Socket                     |                     |                 | Inner<br>Contact  | Outer Contact   |
| ABS0386WF24   | 21-33378-21<br>(L-2119-G)                                | 21-33379-21<br>(L-2119-G)  | 100                 | 8               | M22520/2-01<br>with Positioner Daniels<br>K709<br>(M22520/2-37) | M22520/5-01<br>with Die Set M22520/5-<br>45<br>(Location A & B) |
| ASNE0272TK22  | 21-33378-31<br>(L-2119-G)                                | 21-33379-31<br>(L-2119-G)  | 100                 |                 |   |   |
| ASNE0272TK24  | 21-33378-41<br>(L-2119-G)                                | 21-33379-41<br>(L-2119-G)  | 100                 |                 |   |   |
| Tensolite 24463/9P025X-2(LD)  | 21-33378-51<br>↑   | 21-33379-51<br>↑           | 100                 |                 |   |   |
| GC875TM24H  | 21-33378-61<br>(L-2119-AU)                               | 21-33379-61<br>(L-2119-AU) | 77                  |                 |   |   |
|   | 21-33378-71<br>↑   | 21-33379-71<br>↑           | 110                 |                 |   |   |

| COAX CONTACTS<br>FOR USE IN ARINC 600 & R27 CONNECTORS |  |                          |                 |  |   |
|--|--|--------------------------|-----------------|--|---|
| Cable  | Contact Part Number<br>(Termination Instruction Sheet)** |                          | Contact<br>Size | Crimping Tools                             |   |
|  | Pin  | Socket                   |                 | Inner<br>Contact                           | Outer<br>Contact                                    |
| RG-179   | 21-33676-1<br>(L-2090-B)                                 | 21-33675-1<br>(L-2090-A) | 8               | M22520/2-01<br>with<br>Positioner<br>K1275 | M22520/10-01<br>with Die Set<br>M22520/10-05<br>(A) |
| RG-179   | 21-033476-001  | 21-033475-001            |                 |  |   |
| 5M2869-001   | 21-33676-2<br>↑  | 21-33675-2<br>↑          |                 |  |   |

| PCB QUADRAX CONTACTS<br>FOR USE IN ARINC 600 & R27 CONNECTORS |                     |                  |                     |                 |
|---|---------------------|------------------|---------------------|-----------------|
| PCB<br>Quadrax<br>Contacts                                    | Contact Part Number |                  | Impedance<br>(Ohms) | Contact<br>Size |
|   | Pin                 | Socket           |                     |                 |
| PCB (.346<br>Length)  |                     | 21-33397-<br>171 | 100                 | 8               |
| PCB (.473<br>Length)  | 21-33398-<br>261    |                  |                     |                 |

| TWINAX CONTACTS<br>FOR USE IN ARINC 600 & R27 CONNECTORS |  |                          |                 |                                      |  |
|--|--|--------------------------|-----------------|--------------------------------------|--|
| Cable  | Contact Part Number<br>(Termination Instruction Sheet)** |                          | Contact<br>Size | Crimping Tools                       |  |
|  | Pin  | Socket                   |                 | Inner<br>Contact                     | Outer<br>Contact                       |
| EPD 32263,<br>10612,<br>GSC-12-2548-<br>00               | 21-33631-4†<br>(L-2092-U)†                               | 21-33632-3<br>(L-2092-J) | 12              | MH992<br>with<br>Positioner<br>K1365 | GS200-1<br>with<br>Positioner<br>GP959 |

CONTACT ORDERING: Example number given in chart 21-33382-21 should be ordered as 21-033382-021; example number 21-33382-101 should be ordered as 21-033382-101. Adding Zeros is necessary for Amphenol ordering process on all contact numbers.

† Consult Amphenol Aerospace for current release of this contact or instruction sheet if applicable.

Daniels crimping tools are available from Daniels Mfg. Corp. 6103 Anno Ave., Orlando, FL 32809

\*\*Termination instructions are packaged with each contact and can be found on-line at: [www.amphenol-aerospace.com/serviceinstructions.asp](http://www.amphenol-aerospace.com/serviceinstructions.asp)

Amphenol has today's broadest range of interconnection solutions for military, commercial and industrial applications. As a worldwide interconnection product leader, Amphenol can meet not only connector needs, but also contact needs of all types. In addition to the shielded and high frequency contacts shown in this publication, Amphenol offers many other contact styles:

## PRINTED CIRCUIT BOARD SIGNAL AND POWER CONTACTS

See the Printed Circuit Board section of this catalog.

## THERMOCOUPLE CONTACTS

Available for MIL-DTL-5015, MIL-DTL-22992, MIL-DTL-26482, MIL-DTL-26500, MIL-DTL-38999, MIL-DTL-83723 and other series connectors. Thermocouples are designed for temperature measuring applications, and are available in both pin and socket configurations in alumel, chromel, iron and constantan materials. Please refer to the mil series sections in this catalog.

## FLEX TERMINATION ASSEMBLIES FOR PCB APPLICATION

Flex circuits are available for MIL-DTL-38999, MIL-DTL-5015 and MIL-DTL-26482, as well as for special products such as EMI/EMP filter connectors and rectangular LRM connectors. Please contact an Amphenol Sales Person for more information or visit [www.amphenol-aerospace.com/support](http://www.amphenol-aerospace.com/support) to find a sales person in your area.

## FIBER OPTIC TERMINI

See the Fiber Optic section of this catalog

## FILTER PITYPE TUBULAR AND PLANAR ARRAY CONTACT ASSEMBLIES

See the Printed Circuit Board section of this catalog.

## RADSOK® HIGH POWER CONTACTS

Amphenol's RADSOK® contact design is a hyperbolic, stamped grid configuration within the socket cylinder. As the male pin is inserted, axial members in the female socket half deflect, imparting high current flow across the connection with minimal voltage loss. Another advantage of the RADSOK® contact is low insertion force. The RADSOK® contact has been incorporated into three of the large industrial families of connectors; the GT series, the P-Lok series and 5015 types. These connectors, known as Amphe-Power® connectors, can handle up to 150% higher amperages. Amphenol Industrial Operations division also provides a wide range of power to board interconnects utilizing the RADSOK® technology. These provide high amperage connection to busbars, wires and circuit boards.

RADSOK® contacts are being further introduced into military/aerospace products. High power RADSOK® is now developed into applications for engine connectors for Commercial Air, and are also being designed into LRM interconnects for high speed data transfer. See Amphenol Industrial Brochure, SL-391. (visit [www.amphenol-industrial.com](http://www.amphenol-industrial.com))

See more information on RADSOK® in options, other products section of this catalog pages 419-421.

## RECTANGULAR CONNECTORS

Amphenol provides an impressive array of Rectangular Interconnection products to meet the needs of high density systems such as opto-electrical backplanes used in many applications that include: medical equipment, IC chip testers, tele-communications, military and commercial aviation, military ground vehicles, GPS systems, space and industrial applications.

Available in Low Mating Force with Brush contacts, Power Strip, LRM, ARINC 600 Rack and Panel, and R27 Rack and Panel Rectangular Connectors.

For more information please contact an Amphenol Sales Person on visit [www.amphenol-aerospace.com/support](http://www.amphenol-aerospace.com/support) for a sales person in your area.



PC Tails Signal and Power Contacts and Custom PC Tail Designs. Compliant Pin (Press Fit) Contacts for Solderless Mounting to PC Boards



Sculptured Flex Circuits



RADSOK® High Power Contacts and Connectors



LRM Connectors with Inserts of Staggered Brush Contacts and Inserts of Coax Contacts

III  
II  
I  
SJT  
38999

Matrix 2  
26482

Matrix  
Pyle  
83723 III

Crimp Rear  
Release Matrix  
5015

26500 Pyle

Printed  
Circuit Board

EMI Filter  
Transient

Fiber Optics

High Speed  
Contacts

Options  
Others

38999  
SJT I II III

26482  
Matrix 2

83723 III  
Matrix Pyle

5015  
Crimp Rear  
Release Matrix

26500 Pyle

Printed  
Circuit Board

EMI Filter  
Transient

Fiber Optics

High Speed  
Contacts

Options  
Others

The following check list is provided to help you specify a high frequency contact and cable system, and it will help our design team to meet your requirements. You may copy this page and fax it to Amphenol Aerospace 607-563-5157, attention Contact Design. Or call 607-563-5011 or 800-678-0141 for assistance.

Date \_\_\_\_\_

Amphenol Salesperson \_\_\_\_\_

**CUSTOMER INFORMATION**

Customer Company Name \_\_\_\_\_

Engineer Name \_\_\_\_\_

Program \_\_\_\_\_

Forecast \_\_\_\_\_

**CONNECTOR INFORMATION**

Connector Family: TV-R  LJT-R  JT-R

Other \_\_\_\_\_

Insert Arrangement Desired \_\_\_\_\_

Shell Style \_\_\_\_\_

Shell Plating \_\_\_\_\_

**CABLE INFORMATION**

Cable Part Number\* \_\_\_\_\_

Cable Manufacturer \_\_\_\_\_

Cable Type: Coaxial  Twinax

Triax  Quadrax

Cable Impedance \_\_\_\_\_

**CONTACT INFORMATION**

Type: Coaxial  Concentric Twinax  Triax

Differential Twinax\*  Quadrax\*

Size\*: 8  12  16

Contact Impedance Matched? Yes  No

50Ω  75Ω  100Ω  150Ω  Other \_\_\_\_\_

\* Quadrax and Differential Twinax currently available in size 8 only.

\* if not an RG-Number complete below information:

O.D. of Inner Wire \_\_\_\_\_ AWG of Inner Wires \_\_\_\_\_

No. of Inner Wire Strands \_\_\_\_\_ Material of Inner Wires \_\_\_\_\_

O.D. of Inner Insulation \_\_\_\_\_ Material of Inner Insulation \_\_\_\_\_

O.D. of First Braid \_\_\_\_\_ Braid Type \_\_\_\_\_ Braid AWG \_\_\_\_\_  
(flat, round, wrap)

O.D. of First Jacket \_\_\_\_\_ Jacket Material \_\_\_\_\_

O.D. of Second Braid \_\_\_\_\_ Braid Type \_\_\_\_\_ Braid AWG \_\_\_\_\_  
(flat, round, wrap)

O.D. of Second Jacket \_\_\_\_\_ Jacket Material \_\_\_\_\_

It is essential that a 3 foot sample of the cable be supplied for performance and crimp tool development.

**PERFORMANCE INFORMATION**

Electrical Protocol \_\_\_\_\_

VSWR Requirement 1. to 1. \_\_\_\_\_ Cross Talk \_\_\_\_\_ db

Operating Frequency \_\_\_\_\_ Attenuation \_\_\_\_\_ Insertion Loss \_\_\_\_\_

Operating Voltage \_\_\_\_\_ VAC (RMS) \_\_\_\_\_ DC

Current Outer Contact \_\_\_\_\_ Amp Current Inner Contacts \_\_\_\_\_ Amp

Application Temperature \_\_\_\_\_ Environmental Requirement \_\_\_\_\_



# Amphenol Options, Other Products



Press Fit  
Connectors  
on PC Board



Cable  
Assemblies



38999 Connectors  
with RADSOK®

Custom  
Epoxy Sealed  
Hermetic



Integrated Systems



Amphe-Power  
with RADSOK®



Class 'L'  
Heavy Duty



Rectangular  
Connectors with  
Brush Contacts



## TABLE OF CONTENTS

### Options and Other Products from Amphenol

- Table of Contents . . . . . 415
- Press Fit Connectors for PC Board Applications (38999 Option) . . . . . 416
- Cable Solutions - Value Added Cable Assemblies . . . . . 417, 418
- RADSOK® Contacts for High Power Applications . . . . . 419
- RADSOK® Technology Advantages & Interconnect Solutions . . . 420, 421
- ESD Protected Connectors - Protection from Electrostatic Discharge . 422
- Custom Hermetic/Epoxy Sealed Connectors (38999 Series III Option) . 423
- Durmalon Connector Finish, Alternative to Cadmium . . . . . 424
- Amphenol Integrated Systems, A Leading Choice  
for Packaging Solutions . . . . . 425

### Additional Circular Connectors for a Wide Range of Applications - Military and Industrial

- Amphenol's Wide Range of Circular Interconnects . . . . . 426
- Amphe-Lite, Non-MS Commercial 38999 Type . . . . . 426
- GT, GT-PC, GTC-M Connectors . . . . . 427
- Pyle Star-Line®, Star-Line EX® . . . . . 428
- Amphe-Power™ Connectors with RADSOK® Contacts . . . . . 428, 429
- Class "L", MIL-DTL-22992 . . . . . 429
- QWLD, MIL-DTL-22992, and QWL, MIL-DTL-22992 Type . . . . . 430
- Aquacon Immersible Connectors . . . . . 430
- 67 and 165 Series (5015 Type) . . . . . 431
- 348 Series, MIL-C-81511 Series I & II . . . . . 431
- Shorting Plugs . . . . . 431

### Rectangular Interconnects for a Wide Range of Military Applications

- Low Mating Force Rectangular Connectors with Brush Contacts . . . 432
- Brush Contact Technology . . . . . 432
- Hybrid Rectangular Connector with Brush/Power/Coax/Fiber Combo . 433
- LRM Surface Mount Connectors . . . . . 433, 434
- Pyle LMD & LMS Modular Connectors . . . . . 435
- VME P0/J0 MT Connectors with Fiber Optics . . . . . 435



### Interconnects for Industrial Markets:

- Process Control
- Rail Mass Transportation
- Heavy Equipment
- Energy
- Petrochemical, Power Generation

### Rectangular Interconnect Typical Markets:

- Medical Equipment, Factory Automation
- IC Chip Testers
- GPS Systems, Telecommunications
- Military and Commercial Aviation
- Military Vehicles



38999  
SJT I II III

26482  
Matrix 2

83723 III  
Matrix Pyle

5015  
Crimp Rear  
Release Matrix

26500 Pyle

Printed  
Circuit Board

EMI Filter  
Transient

Fiber Optics

High Speed  
Contacts

Options  
Others

Amphenol manufactures a complete series of MIL-DTL-38999 Series I, II, and III Connectors with Press Fit compliant pin contacts for solderless mounting on printed circuit boards. Both pin and socket contacts are available in any MIL-DTL-38999 Series I, II or III insert pattern having contact size 16, 20 or 22D. Available in Mil-Spec and custom shell configurations.

See section "Series III TV", "Series II JT", and "Series I LJT" for MIL-DTL-38999 Circular Connectors' inserts and shell styles and the PCB section for Press Fit Connectors on Printed Circuit Board applications.

Benefits include:

- High speed, low cost board assembly
- Elimination of soldering thermal stress
- No cold soldered joints
- No short circuits by soldered connections
- No cleaning of excess flux
- Optional contact for piercing conformal board coating is available

Press fit connectors accommodate boards with minimum 0.090 inch thickness and 0.040 +/- .003 plated through holes. The insertion force for mounting the connector on the board is 7 to 16 pounds per contact. Refer to L-40450-207 for installation instructions. Contact Amphenol Aerospace for ordering information.

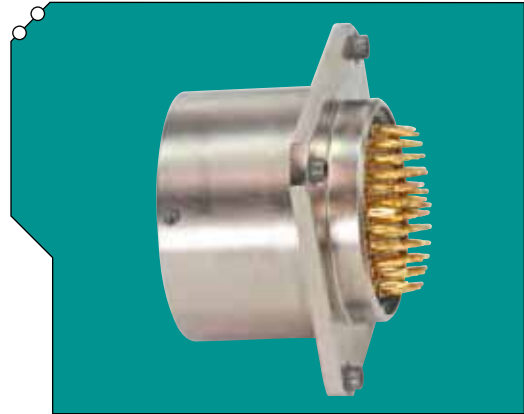

Amphenol Press Fit Connectors for Solderless mounting on printed circuit boards.

Press Fit

Press Fit Connectors on Printed Circuit Board



### Amphenol Press Fit Contact Technology

- Beryllium copper tail, heat treated to spring hardness
- The compliant eye is a natural 2 beam spring
- The eye is oversized relative to the plated through hole and is compressed upon insertion
- After insertion the spring exerts a normal force on the hole creating an electrical path via a tight friction fit





# Cable Solutions

## Value Added Cable Assemblies



With over 100K Sq. Ft. of cable manufacturing space, and multiple locations in North America and Asia, Amphenol Aerospace has diverse capabilities to design and manufacture harsh environment cable assemblies. Our engineers have over 40 years experience designing cables and harnesses to a wide variety of requirements.

From simple point-to-point assemblies to ruggedized overmolded harnesses, Amphenol has the capabilities to meet a diverse range of cable needs.

### Production Capabilities Include:

- Automated twistors, strippers, cutters, crimpers
- Crimp capabilities for 777MCM to 24AWG wire
- Primary wire extrusions/jacketing
- Custom overmold presses with in house production tooling
- Twisted shielded pair and quadrx cable assemblies
- Full testing capabilities for DWV, IR, continuity, etc.



### Markets Currently Served

- Military Vehicles
- Harsh Environments
- Automotive
- Avionics
- Commercial Aerospace
- Rail Mass Transit
- Munitions Communications
- Oil and Gas



III  
II  
I  
SJT  
38999

Matrix 2  
26482

Matrix  
Pyle  
83723 III

Crimp Rear  
Release Matrix  
5015

Pyle  
26500

Printed  
Circuit Board

EMI Filter  
Transient

Fiber Optics

High Speed  
Contacts

Options  
Others

# MARKETS



### Overmolding

- Amphenol excels in overmolding cable technology, perfect for ruggedized power applications.
- Custom overmold solutions utilize either low or high pressure manufacturing methods, and include various environmental materials.
- Overmolding techniques can include straight and right angle mechanical strain relief in a variety of backshells as well as overmolded in SantoPrene® and other elastomeric materials.

### Environmental Capabilities

- Temperature Range: -40° to 200° C capable
- Fluid Resistance: oil, battery acid, hydraulic fluid, diesel
- Flammability: UL94V-O
- Waterproof: IP67

|                         |  |
|-------------------------|--|
| Mold/Press Capability   | Over 40 presses: vertical, horizontal, shuttle base      |
| Shot Size               | 85 cm <sup>3</sup> , Discrete Parts: 200 cm <sup>3</sup> |
| Material                | PA, PPA, PBT, PET, TPV, PU, PP, PVC, ABS... others       |
| Production Tooling Time | Simple Tool: 4-6 wks, Complex/High Volume: 10-12 wks     |
| Type of Process         | Pre-Mold/Pot and Mold                                    |
| Testing Capabilities    | Hi-Pot up to 1000 VDC/AC                                 |
|                         | DWV up to VDC/AC (0.1mA)                                 |
|                         | IR, 1Gohm  |
|                         | Wire Processing, pull test, crimp inspection with CFM    |



### Primary Wire and ArmorLite

- Amphenol is a recognized supplier of primary wire and specialized cable.
- Cable designed for harsh environment applications.
- Production facility includes wire extrusion and cabling lines along with 5 ArmorLite twistors.
- Polyurethane cable jacketing also available.

### ArmorLite Features

- Low cost
- Improved crush factor
- Light weight
- Flexible bend radius
- Abrasion resistant
- Cable sizes .210" to .500"
- Durable, UV stabilized polyurethane cable jacket
- Operational temp -40° to +70° C



### High-Speed Cable Assemblies

Amphenol provides a large array of cable assemblies with high speed quadax and differential twinax contacts, as well as coax and concentric twinax contacts. From a simple one-cable interconnection, to a multiple cable system, Amphenol can design and supply your cable needs for high frequency contacts and connectors.

Cables with various electrical protocols, including:

- 100 Base-T
- 1,000 Base-T, -CX, Gigabit Ethernet
- USB 2.0
- IEEE 1394B Firewire
- Ethernet, USB
- And others

38999  
SJT I II III

26482  
Matrix 2

83723 III  
Matrix Pyle

5015  
Crimp Rear Release Matrix

26500 Pyle

Printed  
Circuit Board

EMI Filter  
Transient

Fiber Optics

High Speed  
Contacts

Options  
Others



RADSOK® technology is based upon a stamped and formed flat grid, uniquely twisted into a hyperbolic geometry to provide robust, high density contact to the mating pin contact. Most pin and socket technologies rely upon spring (beam element) properties of the contact elements, which tend to weaken over time. Unlike most other pin and socket solutions, the RADSOK® also utilizes the tensile strength properties of the flat, high conductivity alloy grid. This provides the high normal forces required for conductivity while also providing large conductive surface area. Correspondingly low voltage drop and low temperature rise are also achieved while maintaining low insertion forces.

- Socket cylinder within female contact has several equally spaced longitudinal beams twisted into a hyperbolic shape.
- As male pin is inserted, axial members in the female half deflect, imparting high current flow across the connection with minimal voltage loss.
- The hyperbolic, stamped grid configuration ensures a large, coaxial, face-to-face surface area engagement.
- Ideal for crimp termination applications requiring repeated mating cycles and high current with a low milli-volt drop.

The RADSOK® (RADial SOcKet) High Amperage, Low Insertion Force Electrical Terminal provides value to your purchasing, engineering, quality and manufacturing objectives.



### Amphenol Mil-Power Connectors

38999 with RADSOK® High Amperage Contacts

- 6 layouts available:
  - Shell size 21 with 4 size 8 RADSOK®
  - Shell size 25 with 4 size 4 RADSOK®
  - Shell size 25 with 1 size 0 RADSOK®
  - Shell size 25 with 2 size 4 RADSOK®
  - Shell size 33 with 2 size 1/0 RADSOK®
  - Shell size 37 with 3 size 1/0 RADSOK®
- Increased current capacity (50% more than standard power)
- Reduced insertion force
- More reliable coupling mechanism (Tri-Start) coupling
- Alternative to cadmium finishes



Amphe-Power 5015 connector with insert pattern 28-5 with (2) size 4 RADSOK® sockets and standard contacts.



Standard RADSOK® socket contacts for Amphe-Power® connectors are available in sizes 0, 4, 8 and 12 crimp or solder. Specific sizes can often be produced more economically than other fastening solutions. Amphenol can tailor the contact design to exact customer needs. See page 428 and 429 for more information about Amphe-Power Connectors.



38999  
III II I SJT

26482  
Matrix 2

83723 III  
Matrix Pyle

5015  
Crimp Rear Release Matrix

26500 Pyle

Printed  
Circuit Board

EMI Filter  
Transient

Fiber Optics

High Speed  
Contacts

Options  
Others



**• HIGH RELIABILITY**

Unique RADSOK® design and construction technology create an electrical contact interface that exceeds typical interconnect requirements. Applications in aerospace, medical, industrial, automotive, mining, offshore, and other harsh environments depend on high reliability of the Amphenol RADSOK® technology.

**• LOW CONTACT ENGAGEMENT/SEPARATION FORCES**

The hyperbolic lamella socket contact construction distributes normal forces over a high percentage of the mating pin surface. This creates a smooth, even engagement effort. This force distribution also contributes to excellent performance in vibration applications with resistance to typical fretting corrosion.

**• LOW CONTACT RESISTANCE**

The large interface area between the socket lamella and pin surface result in very low contact resistance, enabling the RADSOK® contacts' high current ratings compared to traditional power contact designs.

**• HIGH MATING CYCLE DURABILITY**

RADSOK® contacts with typical silver plating finishes have demonstrated survival of 20,000 mating cycles. Specialized plating and contact lubricants can extend cycle life to 200,000 matings or higher. Even with continuous exposure to harsh environmental abuse (salt, sand, and high humidity), RADSOK® contacts have been tested to maintain low contact resistance beyond 10,000 mating cycles.

**RADSOK® Derating Chart – Temperature vs. Current**

Based on single conductors in free air. Wire cross-section same size as pin contact cross-sectional area.



**The Amphenol® RADSOK® Solution to Bring more Power to the Board... Three High Amperage Products: PowerBlok, RADSERT, PGY**

Amphenol's RADSOK® solution offers many options for high current single-point connections to printed circuit boards. The compact footprint design can supply up to 120 Amp to the board which preserves surface area and provides more flexibility in board design.

For more information on RADSOK® products from Amphenol:  
[www.amphenol-industrial.com](http://www.amphenol-industrial.com) and [www.radsok.com](http://www.radsok.com)  
 Contact Amphenol Aerospace Operations, Sidney, NY  
 (Phone: 607-563-5011) or Amphenol Power Solutions, Fraser, MI  
 (Phone: 586-294-7400)

- 38999 SJT I II III
- 26482 Matrix 2
- 83723 III Pyle Matrix
- 5015 Crimp Rear Release Matrix
- 26500 Pyle
- Printed Circuit Board
- EMI Filter Transient
- Fiber Optics
- High Speed Contacts
- Options Others



## Standard and Custom-Developed Solutions

- In addition to the various standard sizes of RADSOK® components, custom-developed solutions are also available. Amphenol has the global design, engineering and manufacturing resources to provide RADSOK® sockets pressed into busbars, crimped to cables, assembled into connectors, assembled into customer or Amphenol designed specialized electrical devices, or as stand-alone components. Amphenol also manufactures a full compliment of mating pin contacts for any application.
- Steady-state current capacities for standard RADSOK® products range from 50 amps to over 1000 amps.
- Standard contact plating is typically Silver (Ag) although many other plating specifications may be used for your application.
- Amphenol connectors with RADSOK® contacts are offered with a variety of positive-locking features that insure and maintain fully-mated connections.
- Sealing (Sealtac™) and high voltage hot break options are available within the RADSOK® itself or within a very wide range of IP rated connector housings to provide environmental protection to the contact area.

## The Wide Variety of RADSOK® Applications include:

- Replacement of ring terminals (lugs) on threaded studs
- High current PCBs
- Communication towers
- Backplane power
- Uninterrupted power supplies
- Fuel cell connectors
- AC inductive drive motors
- Power distribution modules
- Busbar terminations (plug-in hardware/modules)
- “Pluggable” breakers
- Battery terminals
- Contacts with RADSOK® technology give 50% more ampacity.
- RADSOK® contacts can be designed to fit any housing
- Combinations of RADSOK® and high speed copper contacts in the same interconnect package

Amphenol operates quality systems that are certified to ISO9001:2000 by third party registrars.



III  
II  
I  
SJT  
38999

Matrix 2  
26482

Matrix  
Pyle  
83723 III

Crimp Rear  
Release Matrix  
5015

Pyle  
26500

Printed  
Circuit Board

EMI Filter  
Transient

Fiber Optics

High Speed  
Contacts

Options  
Others

Amphenol has developed cylindrical and rectangular connectors which protect sensitive components from Electrostatic Discharge (ESD) without diodes, varistors, gas tubes, or “experimental” semi-conductive materials.

These connectors utilize the Faraday Cage principal to shunt electrostatic discharge events to the conductive enclosure on which the connector is mounted, thus never allowing the high voltage, high current discharge event to reside on any contacts.

The ESD protected connectors have the same physical envelope as their standard counterparts, and do not require special mounting or terminating techniques. All of the contacts remain fully functional, and electrical characteristics such as capacitance are not effected.

### Product Features:

- Connector envelope identical to unprotected design for most applications
- Exceeds protection requirements of IEC 801-2 and MIL-STD-1686:
- Ensures that all components within a conductive enclosure will be subjected to a maximum of 10V during electrostatic discharges between -26 KV and +26 KV
- Voltage observed on contacts during ESD events - <10V (at 1 megohm)
- Current observed on contacts during ESD events - <100 milliamperes (at 2 ohms)
- Response time - instantaneous (voltage and current are maximum values)
- Maximum ESD voltage - tested to ±26KV
- No capacitive loading
- Eliminates the need for discrete components (such as diodes) and maximizes printed circuit board real estate for equipment housed in conductive enclosures which require ESD protection as free-standing units
- Operating voltage of connectors not effected for most designs
- Pulse life - infinite

### What is Electrostatic Discharge (ESD)?

**Electrostatic Discharge (ESD)** is the rapid transfer of a static electric charge from one body to another. A static electric charge consists of either a surplus or depletion of electrons on a body, which gives that body a potential or voltage relative to ground (or another body). The discharge is extremely fast (less than 1 nano-second risetime) and the current flow may exceed 100 amps!

Static electricity is normally the result of two materials transferring charges when rubbed or separated, such as shoes scuffing across a dry carpet, or sheets of untreated plastic being separated. This phenomena is commonly referred to as the triboelectric effect.

The voltage developed due to the triboelectric effect depends on the materials involved, the quantity and type of contact, and relative humidity. In a dry environment a person can accumulate a charge of up to 25 KV! In a moist environment a person's potential is reduced due to the effect of moisture on the insulating properties of materials.



ESD Testing on MIL-DTL-38999, Series III Filter Cylindrical Connector (Actual Photo)

### What is a Faraday Cage?

A **Faraday cage** is a conductive enclosure. It may be solid in form such as a sheet-metal enclosure, or it may be full of apertures, such as a wire cloth box. When a charge is placed on a faraday cage the electrons which make up the charge, having like polarity, try to position themselves as far as possible from each other. This places the electrons on the outer surface of the enclosure, leaving the inner surface uncharged. The charge on the outer surface does not induce a charge on any neutral object inside of the faraday cage, and therefore does not try to transfer itself onto the internal object. Neutral objects (such as IC's) inside of a faraday cage are thereby protected from ESD activity external to the faraday cage.

The voltage and current observed on neutral objects within a faraday cage during ESD events are due to the secondary effects of ESD. These include Electromagnetic Interference (EMI), magnetic and electrical field coupling. The faraday cage of the Amphenol ESD Protected Connectors has been designed to minimize these effects.

### The Amphenol® ESD Protected Connectors

The Amphenol ESD Protected Connectors have a faraday cage at the mating interface. The faraday cage has been specifically designed to intercept electrostatic discharges from the contacts in the unmated state, while maintaining each contact's isolation when the connector is mated. When the ESD Protected Connectors have been mounted to a conductive enclosure, a faraday cage is created which will protect components located within the enclosure from electrostatic discharges. This eliminates the need for discrete components such as diodes and gas discharge tubes, and saves printed circuit board real estate. Amphenol ESD Protected Connectors have also been applied to Line Replaceable Modules (LRM).\*

\* For further information on Amphenol LRM connectors with ESD protection see page 434.

38999  
SJT I II III

26482  
Matrix 2

83723 III  
Matrix Pyle

5015  
Crimp Rear  
Release Matrix

26500 Pyle

Printed  
Circuit Board

EMI Filter  
Transient

Fiber Optics

High Speed  
Contacts

Options  
Others



# Custom Hermetic/Epoxy Sealed Connectors

## Series III TV Options

### Custom Hermetic Connectors

Amphenol glass sealed hermetic connectors are available in a wide variety of Mil-Spec and custom configurations.

Features and benefits:

- Leakage rate of  $1 \times 10^{-7}$  cc of He/sec or less
- Fused glass insert in steel shell

Options include:

- Special flanges
- PC board mounting stand-offs
- PC board mounting tails
- EMI filtering
- Through bulkhead configurations
- Crimp termination

Applications:

- Pressurized avionics boxes
- Environmental sealed boxes
- Moisture sealing for industrial equipment and missiles

(Contact your Amphenol representative for information regarding custom configurations)



### Epoxy Sealed Connectors

Amphenol epoxy sealed connectors are a light weight alternative to glass sealed hermetic connectors for use in avionics and other weight-sensitive applications where a high level of sealing is required. Epoxy sealed connectors are an optimal solution when increasingly stringent water immersion requirements must be met in radio and vetronics applications.

- Same epoxy as used in EMI filter connectors
- Less than  $1 \times 10^{-4}$  cc of He/sec leak rate
- Maintained after temperature cycling, 5 cycles -55 to +125°C
- Custom designs available with lower leak rates upon request
- Available in standard and custom configurations including PC tail, solder cup, and crimp termination, board mounting stand-offs, and through bulkhead configurations.

(Contact your Amphenol representative for information regarding custom configurations)



III  
II  
I  
SJT  
38999

Matrix 2  
26482

Matrix  
Pyle  
83723 III

Crimp Rear  
Release Matrix  
5015

Pyle  
26500

Printed  
Circuit Board

EMI Filter  
Transient

Fiber Optics

High Speed  
Contacts

Options  
Others



Commercial, industrial & military markets are rapidly moving away from hazardous materials such as Cadmium (Cd) & Hexavalent Chrome (Cr6+). Amphenol is offering an alternative finish & process that complies with all customer requirements tied to these specifications.

Cd & Cr6+ have been applied to numerous components of land, sea and air weapon systems for many years & provides sacrificial corrosion protection for steels and excellent lubricity for threaded applications. However, Cd is a toxic metal and a known carcinogen. In addition, Cd is plated from an aqueous bath containing cyanide salts. Cr6+ is a known carcinogen as well.

MIL-DTL-38999 rev L, controlled by the Defense Supply Center Columbus (DSCC) has established 3 new service classes as alternatives to Cd.

- Class P Pure Dense Electrodeposited Aluminum (Alumiplate)
- Class T Nickel Fluorocarbon Polymer (Ni-PTFE)
- Class Z Zinc-Nickel (Zn-Ni)

Amphenol is using this & the European Union directive 2002/95-EC-RoHs (Restriction of Hazardous Substances) as direction to qualification for all domestic, global, commercial, industrial & military specifications requiring the reduction or elimination of these hazardous materials.

At this time, we are focusing on Ni-PTFE, Durmalon, our internal part number coding "DT" finish. Amphenol Durmalon is now QPL'd (qualified) by DSCC to MIL-DTL-38999 Rev L, Series III, Class T. The finish is also RoHS compliant due to the NON-use of Cr6+.

Amphenol also continues to develop a heavy duty Durmalon (Amphenol "DX" p/n code designation) to support the JSF, F-35 program. This plating is intended to meet the additional higher corrosive Sulfur Dioxide (SO<sub>2</sub>)/salt fog requirements of JSF.

Also under development & qualification testing is Zinc-Nickel (Amphenol "DZ" p/n code designation) to comply with the new D38999 class "Z" finish requirements.

Amphenol's Durmalon like Olive-Drab Cadmium plating (Class W), meets 500 hours of Salt Spray, combined with 500 mating cycles and maintains less than a 2.5 millivolt drop shell-to-shell conductivity. Of all platings tested, Durmalon has been proven to meet these requirements and is also being tested under development & showing positive results for the following:

- Sulphur Dioxide (SO<sub>2</sub>) corrosion requirement of the JSF Program
- Potassium Formate- Deicer fluid testing performed by Boeing

Please consult the factory for availability.

### Applications

Interest for non-hazardous alternative finishes is gaining momentum & many customers are currently using Durmalon. As mentioned above, Amphenol is developing a "Heavy Duty" version of Durmalon to comply with the higher level requirements by Lockheed Martin for the F-35, Joint Strike Fighter (JSF) program. The requirements include 2000 hrs of neutral salt fog exposure & an acidic salt fog environment exposure with added sulfur dioxide (SO<sub>2</sub>) for 336 hrs. Please contact the factory for availability.

### Testing

Amphenol Aerospace has performed extensive testing on 14 alternative platings with the most consistent performer being Durmalon. Please contact Amphenol Principal Engineer Eric Shepler at [eshepler@amphenol-aa.com](mailto:eshepler@amphenol-aa.com) for more information or test data on Durmalon.



| Requirements  | Cadmium | Durmalon™ | Zinc Nickel | Alumiplate <sup>sm</sup> | Zinc Cobalt | Stainless Steel | Electroless Nickel |
|---|---------|-----------|-------------|--------------------------|-------------|-----------------|--------------------|
| <b>Coupling Torque</b><br>Post 500 hr salt          | ■       | ■         | NA          | ■                        | NA          | ■               | NA                 |
| <b>Shell-to-Shell Conductivity</b><br><1 millivolts |         |           |             |                          |             |                 | ■                  |
| <2.5 millivolts                                     | ■       | ■         | ■           | ■                        |             |                 |                    |
| <10 millivolts                                      | ■       | ■         | ■           | ■                        |             | ■               |                    |
| <b>Cycles of Durability</b><br>500 mates            | ■       | ■         | ■           | ■                        |             | ■               | ■                  |
| <b>Salt Spray</b><br>48 hours                       | ■       | ■         | ■           | ■                        | ■           | ■               | ■                  |
| Dynamic-500 hours                                   | ■       | ■         | ■           | ■                        |             | ■               |                    |
| 1000 hours  |         | ■*        |             |                          |             |                 |                    |
| <b>Temperature Rating</b><br>175° C                 | ■       | ■         | ■           | ■                        | ■           | ■               | ■                  |
| 200° C  |         | ■         | ■           | ■                        |             | ■               | ■                  |
| >200° C   |         |           |             |                          |             | ■               |                    |
| <b>Non-Reflective</b>                               | ■       | ■         | ■           | ■                        | ■           |                 |                    |
| <b>RoHs Compliant</b>                               |         | ■         | TBD         |                          | ■           | ■               | ■                  |
| <b>Non-Magnetic</b>                                 | ■       | ■         | ■           | ■                        | ■           | ■               | ■                  |
| <b>Available on Composite</b>                       | ■       | ■         | ■           | ■                        | ■           |                 | ■                  |
| <b>Cr6+ Presence</b>                                | ■       |           | TBD         | ■                        | **          |                 | **                 |
| <b>Sulfur Dioxide Resistance</b><br>F35-336 hours   | ■       | *         |             |                          |             |                 |                    |
| <b>Aviform De-Icing Fluid</b>                       |         | TBD       |             |                          |             | ■               |                    |

\* Durmalon XP See "applications"

\*\*Meets EU RoHs/ELV hexavalent chromium maximum concentration value (MCV) of 1000ppm (0.1% w/w) per homogenous material.

Notice: Specifications are subject to change without notice.

38999  
SJT I II III

26482  
Matrix 2

83723 III  
Matrix Pyle

5015  
Crimp Rear  
Release Matrix

26500 Pyle

Printed  
Circuit Board

EMI Filter  
Transient

Fiber Optics

High Speed  
Contacts

Options  
Others

Amphenol is the leading manufacturer of integrated system solutions for the military and aerospace markets. Amphenol Integrated Systems is the synergistic combination of three key divisions:

- **Amphenol Aerospace**
  - **Circular Interconnects**
  - **Rectangular Board Level Products**
- **Amphenol Backplane Systems**
- **Amphenol Printed Circuits**

We have over 60 years of experience in the military and aerospace market and our commitment to the industry is exemplified in everything we do. With our dedicated facilities in Nashua, New Hampshire; Sidney, New York; and Nogales, Mexico, Amphenol Integrated Systems is the military and aerospace industries premier choice for system-level packaging solutions. We understand the relationship between the interconnect, the printed circuit board, the backplane and the chassis. We use that knowledge to provide complete solutions for our customers.

### Amphenol Products-Performance in the Most Demanding Environments

We lead the industry by offering the elements necessary for success in the military and aerospace OEM supply chain:

- Design and Modeling
- Applications Engineering
- Fabrication
- Value-added Assembly
- Test

Coupled with the largest interconnect offering in the market, Amphenol supports all of your system-level needs.

### Integrated System Packaging

Amphenol can provide systems solutions - everything you need inside and outside the box: Interconnect products, printed circuit boards, backplane assemblies, heat-sink and metal enclosures. Amphenol also provides value added assembly including bussing: full system assembly including chassis build and sub-system integration and testing.

An example integrated system box, shown below, includes the following Amphenol interconnect products:

- Circulars: D38999 circular connectors with MT Fiber Optics, RJ Field Connectors
- Rectangulars: LRM interconnects, NAFI connectors, UHD Connectors
- Rectangulars: ARINC 600 connectors, Micro-D Connectors
- Rectangulars: HDB3 High Density Brush contact Connectors
- Backplane Systems, Flex Circuitry, metal enclosure

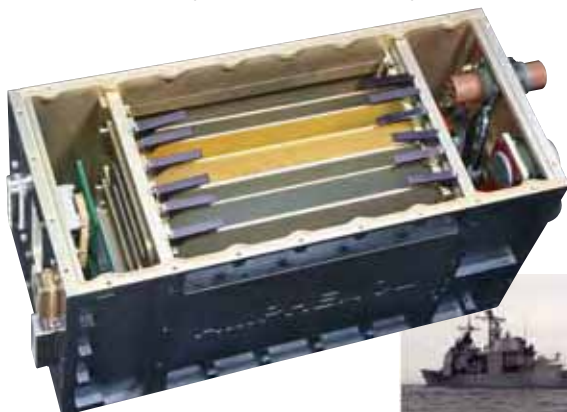

Amphenol Backplane Systems and Printed Circuit Boards

Amphenol's Solutions - The Pinnacle of Technology  
Some of the world's most demanding programs rely on Amphenol's packaging solutions, including:

- **F-35**
- **F-22**
- **F-18**
- **MIDS/JTRS Radio**
- **Theater High Altitude Air Defense Radar (THAAD)**
- **AH-64 Apache**
- **787 Dreamliner**
- **Future combat Systems**
- **DDG-51**
- **DDG-1000**

Integrated Systems solutions are found aboard commercial airliners, helicopters, Navy and Air force Fighters, C4I electronics, missiles, ground vehicles, Homeland Security Systems, and Navy warships.



38999  
III II I SJT

26482  
Matrix 2

83723 III  
Matrix Pyle

5015  
Crimp Rear Release Matrix

26500 Pyle

Printed  
Circuit Board

EMI Filter  
Transient

Fiber Optics

High Speed  
Contacts

Options  
Others



38999  
SJT I II III

26482  
Matrix 2

83723 III  
Matrix Pyle

5015  
Crimp Rear Release Matrix

26500 Pyle

Printed  
Circuit Board

EMI Filter  
Transient

Fiber Optics

High Speed  
Contacts

Options  
Others

### Wide range of Circular Interconnects

Amphenol has the broadest circular interconnect offering in the market place. Amphenol meets or exceeds the following major military specifications for circular connectors:

- MIL-DTL-38999
- MIL-DTL-26482
- MIL-DTL-83723
- MIL-DTL-5015
- MIL-DTL-22992
- MIL-C-81511

### MIL-DTL-5015

A wide range of MIL-DTL-5015 products not covered in this catalog is available online at [www.amphenol-industrial.com](http://www.amphenol-industrial.com) (Catalog 12-020) or refer to page 198 in the MIL-DTL-5015 Crimp Rear Release section of this catalog.

### MIL-DTL-26482

Additional MIL-DTL-26482 Series 1 circular connectors not covered in this catalog is available online at [www.amphenol-industrial.com](http://www.amphenol-industrial.com) (Catalog 12-070) or refer to page 120 in the MIL-DTL-26482 Matrix 2 section of this catalog.

This Catalog covers the majority of Amphenol Aerospace Circular Interconnects. Amphenol also offers many connector choices that serve Industrial Markets such as Process Control, Rail Mass Transit, Heavy Equipment, Energy, Petrochemical, and Power Generation. Some Commercial Circular and Industrial interconnects products are covered on the next pages.



### MIL-DTL-22992

Heavy Duty rugged series of connectors, "Class L", QWLD and QWL are not covered in this catalog. See pages 429 and 430 for brief overviews of these series.

### MIL-DTL-81511

General duty circular connectors 348 series, MIL-C-81511, are not covered in this catalog. See page 431 for brief overview.

### Amphe-Lite™, Non-MS Commercial 38999 Type

Reference Catalog 12-094



| APPLICATION  | STANDARDS/ REQUIREMENTS   | COUPLING/ MOUNTING  | CONTACT TERMINATION   | PERFORMANCE ENVIRON./ELECT.   |
|--|---|---|---|---|
| AL Series Commercial 38999, Series III type connector for higher performance industrial usage. | Offers 38999 type high performance capabilities for severe environment applications, yet is cost effective enough for general duty and non-environmental use. | Threaded coupling. Quickly, completely mates in one 360° turn of the coupling nut. Self locking - lockwiring is eliminated. Universal mounting holes for front or rear mounting, locksmith metal keying to aid in blind mating. | Crimp termination. Recessed pins (100% scoop-proof feature minimizes contact damage). | Operating temp. from -55°C to +125°C. IP67 rating for environmental sealing. Class F provides excellent EMI shielding. Class U provides a non-conductive finish. Composite shells resist severe corrosion. Operating voltage to 900 VAC (RMS) at sea level. |

#### OPTIONAL FEATURES

- 3 shell styles, 59 insert patterns.
- Twinax, coax, filter contacts and fiber optic termini can be incorporated - ideal for communications equipment.
- Ground plane version and high decoupling version available.
- Non-magnetic version available.

#### MARKETS

- Communications
- Medical Equipment
- Automotive

## GT Series, Reverse Bayonet

Reference Catalog 12-024



| APPLICATION  | STANDARDS/ REQUIREMENTS   | COUPLING/ MOUNTING   | CONTACT TERMINATION                 | PERFORMANCE ENVIRON./ELECT.   |
|--|---|--|-------------------------------------|---|
| <p><b>GT Series</b><br/>Heavy duty, rugged connector, environmentally resistant. Preferred connector for mass transit. Also used in mil-aero applications such as military vehicles.</p> | <p>Utilizes MIL-DTL-5015 inserts. UL recognized. Intermateable with VG95234 connectors.</p> | <p>Reverse bayonet coupling (quick mating, audible, visual and tactile full mating indicators). Rated to 2000 couplings min. No lockwiring required.</p> | <p>Crimp or solder termination.</p> | <p>Operating temp. from -55°C to +125°C. With Viton inserts: -50°C to +200°C. Resilient inserts provide high dielectric strength and moisture barrier. IP67 performance in environmental versions. Resilient rubber covers provide higher shock and vibration capabilities. Operating voltage to 3000 VAC (RMS) at sea level.</p> |

### OPTIONAL FEATURES

- Over 40 varieties of shell styles and backend accessory combinations.
- Optional insert materials: Neoprene, Viton\*, or low smoke/flame retardant.
- Variety of conductive and non-conductive platings including non-cadmium.
- Resilient cover coupling nuts available for added damage protection and increased gripping surface.
- Many contact types are available, including both gold and silver plating, and alternate crimp barrel sizes.
- Available with RADSOK® High Power Contacts- see page 429

### MARKETS

- Rail/Mass Transportation
- Power Generation, Petro-Chemical
- Heavy Equipment, Geophysical
- Power and Control Lighting Trusses
- Military Vehicles

## GT-PC Series for High Power Applications

Reference Catalog 12-024



| APPLICATION   | STANDARDS/ REQUIREMENTS   | COUPLING/ MOUNTING   | CONTACT TERMINATION       | PERFORMANCE ENVIRON./ELECT.  |
|---|---|--|---------------------------|--|
| <p><b>GT-PC Series</b><br/>Same standard features as the GT series, but with "Dead Front" pin contacts, size 0, recessed into the socket insert. Provides higher amperage capability and operator safety by preventing inadvertent contact with a live contact.</p> | <p>UL recognized. Currently available with 5 insert patterns incorporating size 0 contacts.</p> | <p>Reverse bayonet coupling (quick mating, audible, visual and tactile full mating indicators). Rated to 2000 couplings min. No lockwiring required.</p> | <p>Crimp termination.</p> | <p>Same performance as GT series, but special "Dead Front" recessed contacts provide higher amperage levels - up to 100 amps per contact. These special contacts also prevent accidental electrical shocks to technicians. "First Mate"/"Last Break" features on one or more of the pins provide additional operator safety.</p> |

### OPTIONAL FEATURES

- Same shell styles offered as in standard GT series family.
- Currently 5 insert patterns available.
- Wide selection of backend accessories available.

### MARKETS

- High Voltage Power Distribution

## GTC-M Series - The GT with Metal Clip Inserts

Reference Catalog 12-024.  
Reference PDS-181  
(Product Data Sheet)



| APPLICATION  | STANDARDS/ REQUIREMENTS   | COUPLING/ MOUNTING   | CONTACT TERMINATION                 | PERFORMANCE ENVIRON./ELECT.  |
|--|---|--|-------------------------------------|--|
| <p><b>GTC-M Series</b><br/>Combines the GT reverse bayonet shell and the rear release metal clip retention system which is used in the Amphenol®/Matrix® MIL-DTL-5015 connector. Provides easier insertion/removal of contacts and improved environmental sealing.</p> | <p>Intermateable and inter-mountable with standard GT series.</p> | <p>Reverse bayonet coupling (quick mating, audible, visual and tactile full mating indicators). Rated to 2000 couplings min. No lockwiring required. Captivated coupling nut assembly allows unmating without the rear accessories attached.</p> | <p>Crimp or solder termination.</p> | <p>Operating temp. from -55°C to +200°C. Completely environmentally sealed with contact seals, gaskets, wire seals and insert-to-shell seals. IP67 rating for environmental sealing. Operating voltage to 3000 VAC (RMS) at sea level.</p> |

### OPTIONAL FEATURES

- 7 shell styles offered with all insert patterns available from standard GT series family.
- Wide selection of backend accessories available.

### MARKETS

- Mass Transportation
- Power Generation, Petro-Chemical
- Heavy Equipment, Geophysical

III  
II  
I  
SJT  
38999

Matrix 2  
26482

Matrix  
Pyle  
83723 III

Crimp Rear  
Release Matrix  
5015

Pyle  
26500

Printed  
Circuit Board

EMI Filter  
Transient

Fiber Optics

High Speed  
Contacts

Options  
Others

### Pyle Star-Line®

Reference Catalog 12-054



| APPLICATION   | STANDARDS/ REQUIREMENTS  | COUPLING/ MOUNTING  | CONTACT TERMINATION   | PERFORMANCE ENVIRON./ELECT.   |
|---|--|---|---|---|
| Heavy duty, environmental circulars for high amperage and high density control and instrumentation applications. Rugged, double lead threaded. <u>ZP/ZR designations.</u> | Equals or exceeds MIL-DTL-5015 E and R specifications. UL listed and CSA listed for circuit breaking capability. | Double lead Acme threads provide complete coupling in one turn of the coupling nut, and do not clog under adverse weather conditions. Large wiring space provided in cable housings and conduit fitting bodies. | Solder, crimp and pressure terminals. Circuit breaking power and control types. | Operating temp. from -67°F to +257°F. IP67 rating for environmental sealing. Hard anodic coating provides dielectric strength with heat and corrosion resistance. Up to high amperage of 1135 amps at 1000VAC or DC rating available. |

#### OPTIONAL FEATURES

- 5 shell styles with over 150 insert patterns.
- 3 retention styles with captive contacts or insertable/removable contacts.
- Contact inserts and adapters are interchangeable and reversible to suit special needs.
- Thermocouple contacts available.
- Variety of backend accessories including basket weave cable grips, straight or angled adapters, and receptacle mounted to junction boxes.

#### STAR-LOK® SERIES ALSO AVAILABLE. Reference Catalog 12-054.

- High power and rugged features of the Star-Line series, but with spring loaded reverse bayonet coupling.
- Same choices of inserts, contacts and hardware as Star-Line.
- Solder, crimp and pressure terminals. Circuit breaking power and control types.

#### MARKETS

- Mass Transportation
- Oil Exploration & Production Equip.
- Automotive Tooling
- Motor Operated Valves
- Co Generation Equip.

### Pyle Star-Line EX®

Reference Catalog 12-054



| APPLICATION  | STANDARDS/ REQUIREMENTS   | COUPLING/ MOUNTING  | CONTACT TERMINATION   | PERFORMANCE ENVIRON./ELECT.   |
|--|---|---|---|---|
| Heavy duty, environmental circulars for high power applications with harsh/potentially explosive environments. Rugged, double lead threaded. <u>EX designations.</u> | Hybrid form of the Star-Line series with higher temperature ranges. Cenelec Certified for use in Zone 1-IIC hazardous environment.  EX Certificate #03ATEX 1101X | Double lead Acme threads provide complete coupling in one turn of the coupling nut, and do not clog under adverse weather conditions. Large wiring space provided in cable housings and conduit fitting bodies. | Solder, crimp and pressure terminals. Circuit breaking power and control types. | Operating temp. from -65°C to +257°C. IP67 rating for environmental sealing. Hard anodic coating provides dielectric strength with heat and corrosion resistance. Up to high amperage of 1135 amps at 1000VAC or DC rating available. |

#### OPTIONAL FEATURES

- 5 shell styles with same insert patterns of Star-Line series.
- Variety of backend accessories including basket weave cable grips, straight or angled adapters, and receptacles mounted to junction boxes.
- Can be terminated onto unarmored or armored and sheathed cables built to several popular standards. Custom cable assemblies available.

#### MARKETS

- Mass Transportation
- Aircraft Refueling Pits
- Petro-chemical
- Pharmaceutical Mfg. Equip.
- Off-shore oil drilling
- Automotive paint booths

### Amphe-Power™ P-Lok Connectors

Reference Brochure SL-391



Amphe-Power P-Lok



Amphe-Power 14mm P-Lok

| APPLICATION   | STANDARDS/ REQUIREMENTS   | COUPLING/ MOUNTING  | CONTACT TERMINATION  | PERFORMANCE ENVIRON./ELECT.   |
|---|---|---|--|---|
| Amphe-Power P-Lok connectors are designed for high amperage usage in industrial and transportation applications.  | P-Lok and MIL-DTL-5015 characteristics, enhanced with RADSOK for higher amperage usage. | Spring pressure push-pull mating of the P-Lok series. Audible and tactile conformation of positive locking. | Crimp termination. Amphe-Power P-Lok connectors have RADSOK contacts, available in size 8 (69 amps), size 4 (120 amps), and size 0 (250 amps). The 14mm Amphe-Power design has size 28 shell, and a single crimp pin contact in 2/0 or 4/0 AWG size. The receptacle has the 14mm RADSOK® socket with crimp or busbar-mount terminations available. | Meets same performance levels as P-Lok. RADSOK socket is rated for 500A continuous duty. Environmentally sealed to IP67.  |
| <b>OPTIONAL FEATURES</b>  |   |   |  | <b>MARKETS</b>  |
| <ul style="list-style-type: none"> <li>• Standard connector options available, electroless nickel finish on the shell.</li> <li>• Dead-front pin contacts are available.</li> <li>• UL recognized leakage paths is an option.</li> <li>• Touch-proof sockets are available.</li> <li>• Custom over-molded cable solutions. Neoprene, Hypalon and other materials are available in both straight and right-angle wire orientations.</li> </ul> |   |   |  | <ul style="list-style-type: none"> <li>• Power Generation, Petro-Chemical</li> <li>• Rail/Mass Transportation</li> <li>• Fuel Cells, Energy Storage, Power Motors</li> <li>• Hybrid Vehicles</li> </ul> |

- 38999 SJT I II III
- 26482 Matrix 2
- 83723 III Pyle Matrix
- 5015 Crimp Rear Release Matrix
- 26500 Pyle
- Printed Circuit Board
- EMI Filter Transient
- Fiber Optics
- High Speed Contacts
- Options Others



## Amphe-Power™ GT, Amphe-Power™ 5015 (AC)

Reference Brochure SL-391



Amphe-Power GT



Amphe-Power 5015 AC

| APPLICATION   | STANDARDS/ REQUIREMENTS   | COUPLING/ MOUNTING   | CONTACT TERMINATION  | PERFORMANCE ENVIRON./ELECT.   |
|---|---|--|--|---|
| High amperage capability connectors designed for the most demanding industrial and transportation applications. <u>Amphe-Power GT designation: GT( )RDS</u><br><u>Amphe-Power AC designation: AC( )R( ) designation</u> | GT and 5015 (AC) connectors enhanced with RADSOK® contacts (hyperbolic, stamped grid configuration within the socket) that handle up to 150% higher amperages than standard contacts. | Amphe-Power GT is reverse bayonet coupling. Amphe-Power 5015 is threaded coupling. | Crimp termination. RADSOK® contacts, available in size 8 (69 amps), size 4 (120 amps), and size 0 (250 amps). For RADSOK® contact advantages, see page 79. | Amphe-Power connectors are all 5015 type performance. Operating temp. from -55°C to +125°C. GT and 5015 styles are IP67 similar performance in environmental versions. Current Amphe-Power lines support from 50A to over 500A continuous duty. |

### OPTIONAL FEATURES

- Most shell styles available in GT family and in AC 5015
- Hybrid arrangements with RADSOK and power contacts tailored to meet customer needs.

\* Amphenol AC Threaded Series- Reference catalog 12-025  
Amphenol AC-B Reverse Bayonet Series - Reference 12-027

### MARKETS

- Power Generation, Petro-Chemical
- Mass Transportation

## Amphe-Power™ Composite Amphe-GTR

Reference Brochure SL-391



| APPLICATION  | STANDARDS/ REQUIREMENTS  | COUPLING/ MOUNTING        | CONTACT TERMINATION   | PERFORMANCE ENVIRON./ELECT.   |
|--|--|---------------------------|---|---|
| <u>Amphe-GTR</u><br>GT connector with RADSOK® high amperage sockets. The plug shell, coupling nut, receptacle and hardware are all high performance molded composite material. | Listed per UL1977/UL1682/UL817. Meets all the specifications for high power process control and server applications. | Reverse bayonet coupling. | Compression (setscrew) wire termination to the 4/6AWG or 8/10AWG conductors allows easy field replacement of pin or socket contacts, or complete plug and receptacle assemblies, without requiring specialized tooling. | Meets same performance levels as GT series. (See page 427). RADSOK® contacts enable increased current ratings to 120A on individual contacts. Utilizes a standard PG adapter to achieve IP67 seal rating. Flammable rated to UL94V-0. |

### OPTIONAL FEATURES

- Currently available in shell size 32 with 4 or 5AWG contacts. Consult Amphenol Power Solutions for future sizes and patterns.

### MARKETS

- Factory Automation
- Rail/Mass Transportation
- Process Control

## Class “L”, MIL-DTL-22992

Reference Catalog 12-052



| APPLICATION   | STANDARDS/ REQUIREMENTS  | COUPLING/ MOUNTING  | CONTACT TERMINATION                          | PERFORMANCE ENVIRON./ELECT.   |
|---|--|---|--|---|
| <u>Class L Military MS90555 and Proprietary designs.</u><br>Heavy duty, rugged, environmental circulars designed to meet the heaviest electrical loads for military or industrial applications. Current ranges of 40 to 200 amps, conductor sizes 6 to 4/0. Automatic grounding for safety. | Qualified to MIL-DTL-22992. Within the controlled parameters of mil-spec - shell size relationship to current carrying capacity to reduce the possibility of inadequate wiring for heavy electrical loads. | Double stub threaded per MIL-STD-1373 for fast coupling, easy cleaning. 5 key polarizing system assures that circuits with incompatible power characteristics (voltage, phase and frequency) are not mated. Rated to 500 complete mating/unmating cycles. | Crimp termination. Contacts can be soldered. | Operating temp. from -55°C to +125°C. Unique arc quenching capability provides a positive safety feature if connectors are inadvertently disconnected under load. Programmed coupling sequence - grounding and neutral contacts engage before power contacts. Grommets and seals provide waterproofing. Rugged shells are resistant to vibration, high impact, shock and corrosion. |

### OPTIONAL FEATURES

- Direct current or single/three phase, 60/400 Hertz alternating current.
- 4 shell styles with 7 insert patterns that facilitate large conductors.
- Accessories have left hand threads to minimize cable twisting, wire breakage, accidental connector disassembly.
- Conductive and non-conductive finishes available.

### MARKETS

- Military ground vehicles/Mobile facilities
- Geophysical/Heavy equipment
- Power distribution systems

|                           |              |
|---------------------------|--------------|
| III                       | 38999        |
| II                        | 26482        |
| I                         | 83723 III    |
| SJT                       | 5015         |
| Matrix 2                  | 26500 Pyle   |
| Matrix                    | Printed      |
| Pyle                      | EM1 Filter   |
| Crimp Rear Release Matrix | Transient    |
| 5015                      | Fiber Optics |
| 26482                     | High Speed   |
| 83723 III                 | Contacts     |

Options  
Others

- 38999 SJT I II III
- 26482 Matrix 2
- 83723 III Pyle Matrix
- 5015 Crimp Rear Release Matrix
- 26500 Pyle
- Printed Circuit Board
- EMI Filter Transient
- Fiber Optics
- High Speed Contacts
- Options Others

### QWLD, MIL-DTL-22992

Reference Catalog 12-052

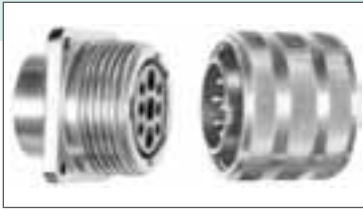

#### OPTIONAL FEATURES

- 7 shell styles with over 300 insert patterns that include both MS and special patterns for a wide variety of multiconductor cables.
- Coax and thermocouple contacts available.
- Accessories have left hand threads to minimize cable twisting, wire breakage, accidental connector disassembly.
- Alumilite hard anodic finish for abrasion and corrosion resistance or conductive cadmium plate finish.

#### QDP SERIES ALSO AVAILABLE - Consult Amphenol for further information.

- QWLD type shells with miniature crimp (PT-SE) inserts.
- Applications which require heavy duty shells, rugged finish, higher contact density.

#### APPLICATION

QWLD Military MS17343 and Commercial designations. Heavy duty, rugged, environmental circular designed for power and control circuits. Increased shell size compared to standard 5015 connectors for greater durability. Industrial version available.

#### STANDARDS/ REQUIREMENTS

MS approved versions qualified to MIL-DTL-22992. Incorporates MIL-DTL-5015 inserts plus special arrangements. Class C: pressurized. Class R: environmental.

#### COUPLING/ MOUNTING

Double stub threaded per MIL-STD-1373 for fast coupling, easy cleaning. 5 key polarization. Rated to 500 complete mating/unmating cycles.

#### CONTACT TERMINATION

Crimp or solder termination.

#### PERFORMANCE ENVIRON./ELECT.

Operating temp. from -55°C to +125°C. Resilient inserts provide high dielectric strength and moisture barrier. Sealing gaskets at every joint for waterproofing. Rugged shells are explosion proof and are resistant to vibration and shock, hydraulic fluids, oils and salt spray corrosion. Operating voltage to 3000 VAC (RMS) at sea level.

#### MARKETS

- Military ground vehicles/Heavy equipment
- Geophysical
- Portable lighting systems
- Power distribution systems

### QWL, MIL-DTL-22992 Type

Reference Catalog 12-053



#### OPTIONAL FEATURES

- 8 shell styles with over 300 insert patterns that include both MS and special patterns for a wide variety of multiconductor cables.
- Coax and thermocouple contacts available.
- Accessories have left hand threads to minimize cable twisting, wire breakage, accidental connector disassembly.
- Alumilite hard anodic finish for abrasion and corrosion resistance or conductive cadmium plate finish.

#### APPLICATION

QWL Series Commercial only. Heavy duty, rugged, environmental circulars designed to be more compact. Provides an economical alternative to military qualified designs for heavy duty connectors.

#### STANDARDS/ REQUIREMENTS

Commercial styles with performance levels that equal to MIL-DTL-22992. Incorporates MIL-DTL-5015 inserts plus special arrangements.

#### COUPLING/ MOUNTING

Double stub threaded per MIL-STD-1373 for fast coupling, easy cleaning. Single keyway polarization. Rated to 500 complete mating/unmating cycles.

#### CONTACT TERMINATION

Crimp or solder termination.

#### PERFORMANCE ENVIRON./ELECT.

Operating temp. from -55°C to +125°C. Resilient inserts provide high dielectric strength and moisture barrier. Sealing gaskets at every joint for waterproofing. Rugged shells are resistant to vibration and shock, hydraulic fluids, oils and salt spray corrosion. Operating voltage to 3000 VAC (RMS) at sea level.

#### MARKETS

- Instrumentation/Control/Machine Tool
- Communications
- Nuclear Industry
- Geophysical

### Aquacon Immersible Connectors

Reference Catalog 12-140



#### OPTIONAL FEATURES

- Straight plug and either jam nut or square flange receptacle styles offered.
- Over 40 insert arrangements available.
- Hermetic receptacles are available with inserts of fused compression glass.

#### APPLICATION

AJ Series Designed for underwater or fluid immersion applications, offering 1500 psi sealing capability assured by metal to metal threaded coupling and "O" ring seals.

#### STANDARDS/ REQUIREMENTS

MIL-DTL-38999 Series III type, with enhanced features for moisture sealing and corrosion resistance.

#### COUPLING/ MOUNTING

Threaded coupling. Quick mating with one 360° turn of the coupling nut. Visual mating indicator.

#### CONTACT TERMINATION

Crimp termination. Recessed pins (100% scoop-proof feature minimizes contact damage). Solder termination for hermetic receptacles.

#### PERFORMANCE ENVIRON./ELECT.

Operating temp. from -55°C to +200°C. Specially designed aluminum bronze coupling nut and type 316 stainless steel shells resist corrosion and provide a 1500 pressure withstanding capability. Hermetic style inserts provide 1 x 10<sup>-6</sup> cc/sec leakage rate. Rear accessory thread provides for the use of EMI hardware or environmentally resistant molded cable terminations.

#### MARKETS

- Oceanic and fluid immersion applications.

# Additional Circular Connectors

## For a Wide Range of Applications, Military & Industrial

### 67 Series, Connectors

Reference Catalog 12-023



#### OPTIONAL FEATURES

- 5 shell styles with 17 insert patterns.
- 4 construction classes for unitized back end grommet or optional wire sealing, clamping and potting styles.

| APPLICATION  | STANDARDS/ REQUIREMENTS   | COUPLING/ MOUNTING              | CONTACT TERMINATION   | PERFORMANCE ENVIRON./ELECT.  |
|--|---|---------------------------------|---|--|
| <b>67 Series</b><br>Environmentally sealed, medium size connector. Designed to meet MIL-DTL-5015 specifications, but lighter weight, with gray anodized aluminum shell and bayonet coupling. | Meets temperature ranges and moisture resistance of MIL-DTL-5015 requirements with potting. Miniaturized size (approx. half the weight of standard MIL-DTL-5015 connectors). UL approved. | Spring-loaded bayonet coupling. | Crimp rear insertable, rear releasable contact termination. | Operating temp. from -55°C to +125°C. IP67 rating for environmental sealing. Operating voltage to 1800 VAC (RMS) at sea level. |

- MARKETS**
- Military Aircraft
  - Missiles

### 165 Series, Connectors

Reference Catalog 12-023



#### OPTIONAL FEATURES

- 5 shell styles with 7 insert patterns.
- Styles for jacketed cable attachment or for potting.

| APPLICATION   | STANDARDS/ REQUIREMENTS   | COUPLING/ MOUNTING | CONTACT TERMINATION   | PERFORMANCE ENVIRON./ELECT.  |
|---|---|--------------------|---|--|
| <b>165 Series</b><br>Environmentally sealed, medium size connector. Designed to meet MIL-DTL-5015 Class C specifications, but lighter weight, with gray anodized aluminum shell and bayonet coupling. | Meets temperature ranges and moisture resistance of MIL-DTL-5015 requirements with potting. Miniaturized size (approx. half the weight of standard MIL-DTL-5015 connectors). UL approved. | Bayonet coupling.  | Crimp rear insertable, rear releasable contact termination. | Operating temp. from -55°C to +125°C. IP67 rating for environmental sealing. O-ring seals in both plug and receptacles make connectors pressure proof and water protected when mated. Operating voltage to 600 VAC (RMS) at sea level. |

- MARKETS**
- Military Aircraft
  - Missiles

### 348 Series, MIL-C-81511 Series I & II

Reference Catalog 12-093



| APPLICATION   | STANDARDS/ REQUIREMENTS                               | COUPLING/ MOUNTING                               | CONTACT TERMINATION  | PERFORMANCE ENVIRON./ELECT.   |
|---|---|--|--|---|
| <b>348 Series M81511</b><br>For general duty requirements. Series II is standard length, Series I is longer shell with recessed pins. | MS versions are approved to MIL-C-81511 Series I & II | 3 point bayonet coupling and 5 key/keyway mating | Crimp termination. Series I has recessed pins (100% scoop-proof feature minimizes contact damage). | Operating temp. from -55°C to +200°C. IP67 rating for environmental sealing. Operating voltage to 600 VAC (RMS) at sea level. |

- OPTIONAL FEATURES**
- 4 shell styles available.
  - Series I with longer shells, recessed pins offers 28 insert patterns.
  - Series II with standard shells offers 16 insert patterns.
  - Shielded coax contacts available.

- MARKETS**
- Military Aerospace
  - Military Vehicles
  - Commercial Aircraft
  - Medical Equipment

### Shorting Plugs

Consult your local Amphenol sales office for further information.



#### OPTIONAL FEATURES

- Available with various lengths and attachments to meet customer requirements.

| APPLICATION   | STANDARDS/ REQUIREMENTS   | COUPLING/ MOUNTING                           | CONTACT TERMINATION                           | PERFORMANCE ENVIRON./ELECT.                   |
|---|---|--|---|---|
| Modified plugs or receptacles in all major mil-spec cylindrical connector types. Modified with a tethered eyelet/braid attachment. Designed to provide specific circuit functions such as safety shorting, electrical commoning and arming. | Available modification design with the following series:<br>MIL-DTL-26482<br>MIL-DTL-38999<br>MIL-DTL-5015<br>MIL-DTL-83723 | Available with a tethered eyelet attachment. | Termination is per connector series utilized. | Performance is per connector series utilized. |

- MARKETS**
- Missiles

III  
II  
I  
SJT  
38999

Matrix 2  
26482

Matrix  
Pyle  
83723 III

Release Matrix  
Crimp Rear  
5015

26500 Pyle

Printed  
Circuit Board

EMI Filter  
Transient

Fiber Optics

High Speed  
Contacts

Options  
Others

38999  
SJT I II III

26482  
Matrix 2

83723 III  
Matrix Pyle

5015  
Crimp Rear Release Matrix

26500 Pyle

Printed  
Circuit Board

EMI Filter  
Transient

Fiber Optics

High Speed  
Contacts





Options  
Others

### Wide range of Rectangular Interconnects

Amphenol provides an impressive array of Rectangular Connectors to meet the needs of high density systems and interconnect attachments to Printed Circuit Boards. The Low Mating Force Rectangulars have proven performance on the ground, in the air, and at sea. Applications include: M1A2 Abrams, F-16 Falcon, F/A-22 Raptor, F-35 Lightning 11, AIM-132, ASRAAM. The LRM Surface Mount Connectors shown on page 433 & 434 also have met the needs of major programs that include:

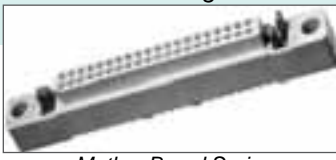
F-35, F-16, F-15, F/A-22, F/A-18, B2, JTRS, EH101, Sincgars, ATACMS, M1 Tanks, Grippen, F-117, Harpoon, LANTRIN, AH-64 APACHE, ASRAAM, ATFLIR

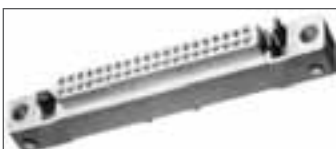
### Low Mating Force Rectangular Connectors with Bristle Brush Contacts

| Reference Catalog 12-035*   | APPLICATION  | STANDARDS/ REQUIREMENTS                                       | COUPLING/ MOUNTING  | CONTACT TERMINATION/ ARRANGEMENTS   | PERFORMANCE ENVIRON./ELECT.  |
|---|--|---|---|---|--|
| <br><i>Mother Board Series</i>   | <p><b>Military designation:</b> M55302.<br/><b>Proprietary designations:</b> MB, DB, I/O, PC.</p> <p>Rectangular connectors for attachment to printed circuit boards. Offers high contact density capability. Contain Bristle Brush contacts, consisting of multiple strands of high tensile strength wire that are bundled together to form a "brush-like" contact.</p> | <p>Military versions meet MIL-DTL-55302/166 through /172.</p> | <p>For mounting to printed circuit boards or discrete wires. Body styles offered:</p> <ul style="list-style-type: none"> <li>• Mother board</li> <li>• Daughter board</li> <li>• Input/Output</li> <li>• PC</li> </ul> <p>Flexibility in mating:</p> <ul style="list-style-type: none"> <li>• Perpendicular boards</li> <li>• End to end boards</li> <li>• Parallel boards</li> <li>• Wire to boards</li> <li>• Card extenders.</li> </ul> <p>Polarization keys provide up to 256 possible positions.</p> | <p>Brush contact termination. (Also called B3 contacts).<br/>Termination Styles:</p> <ul style="list-style-type: none"> <li>• PCB through-hole solder</li> <li>• Wire wrap (MB only)</li> <li>• Crimp to discrete wires (Input/Output only)</li> <li>• Solderless complaint into 0.040 plated through holes (MB only)</li> </ul> <p>Arrangements:</p> <ul style="list-style-type: none"> <li>• 2, 3 or 4 row arrangements with 10 to 100 contacts per row in one contact per row increments.</li> <li>• 0.100 inch center to center square grid contact spacing.</li> </ul> | <p>Operating temp. from -65°C to +125°C.<br/>Connector bodies are high performance glass-filled thermoplastic moldings. Connector configurations are capable of supporting data rates up to 400 Mbps.</p> <p>Bristle Brush contacts provide:</p> <ul style="list-style-type: none"> <li>• Low mating/unmating forces - 70% to 90% reduction from conventional pin and socket contacts.</li> <li>• Proven durability and long contact life - over 20,000 cycles of mating and unmating without performance degradation.</li> <li>• Multiple points (14-17) of contact per mated contact.</li> <li>• Intermittency-free performance.</li> <li>• Redundant current paths (stable, low resistance).</li> <li>• Proven electrical and gas tight contact sites.</li> </ul> |
| <br><i>Daughter Board Series</i> |  |   |   |   |  |
| <br><i>Input/Output Series</i>   |  |   |   |   |  |
| <br><i>PC Series</i>           |  |   |   |   |  |
|   |  |   |    |   |  |
|   | <p><i>Variety of Rectangular Brush Connectors including smaller styles that have only 10 contacts and are available in color coded moldings.</i></p>   |   |   |   |  |

#### OPTIONAL FEATURES

- Locking screws and bushings are available for attaching connectors to boards.
- Contact styles available: straight, 90 degree, PCB stub, wire wrap and crimp.
- Small 10-contact arrangement styles are available with option of multi-colored moldings for color coding applications.

#### MARKETS

- Medical Equipment
- Military and Commercial Aviation
- IC Chip Testers
- Military Vehicles
- GPS Systems
- Space applications
- Telecommunications
- Factory Automation

### Low Mating Force High Cycle, Bristle Brush Contacts

As mentioned in the Rectangular section of this publication, the Amphenol Low Mating Force and Amphenol LRM Surface Mount Connectors utilize the Bristle Brush contact design. The Brush or B<sup>3</sup> contact is made up of multiple strands of high tensile wire that are bundled together. 70% to 90% reduction in mating/unmating forces is achieved over conventional contacts, and the brush contact has proven durability and long contact life. Hybrid Low Mating Force connectors can be designed with combinations of brush and coax/twinax/power contacts or fiber optic termini. LRM Surface Mount Connectors can also be designed with combinations of contact styles.



**Bristle Brush Contacts - Multiple Stands of Wire are Bundled together to form a "Brush-like" Contact**

\*Amphenol is developing a combined rectangular catalog 12-R1. 12-035,12-037 and LM-300 will be included in the combined rectangular catalog please contact Amphenol Aerospace for future availability.



# Rectangular Interconnects

## For a Wide Range of Applications, Military



### Hybrid Rectangular Connectors with Brush/Power/Coax/Fiber Optic Combinations

Reference Catalog 12-035



Power/Coax/Brush Contact Combinations



Fiber Optics/Brush Contact Combinations

| APPLICATION   | STANDARDS/ REQUIREMENTS   | COUPLING/ MOUNTING   | CONTACT TERMINATION/ ARRANGEMENTS  | PERFORMANCE ENVIRON./ELECT.  |
|---|---|--|--|--|
| Rectangular connectors for attachment to printed circuit boards. Offers versatility of combining contact types- power, coax, twinax, fiber optics and Brush contacts in one high density package. | M55302 type rectangular connectors with hybrid contact arrangements. Power contacts and shielded coax or twinax contacts meet M39029 standards. Fiber optic termini meet M29504/4 & /5 standards. | Same as shown above for Low Mating Force rectangular connectors. | Combinations of termination styles: <ul style="list-style-type: none"> <li>• Brush contacts (as described above)</li> <li>• Power contacts - (standard M39029 size 16 or 12; same as used in MIL-DTL-38999 Series II)</li> <li>• Coax or twinax contacts - (M39029, size 16 and 12)</li> <li>• Fiber optic termini (multi-mode size 16; same as used in MIL-DTL-38999 Series III)</li> </ul> | Connector performance and brush contact performance is the same as shown above for Low Mating Force Rectangular connectors. Optical performances of fiber optic termini are the same as termini used in multi-channel circular connectors. |

#### OPTIONAL FEATURES

- Hybrid configurations are available with fiber optics and brush contacts. (See photo above and Fiber Optic section of this catalog).
- Hybrid configurations are available with power and/or shielded (coax or twinax contacts). (See photo shown above).

### LRM Surface Mount Connectors with Brush Contacts

Reference Catalog 12-037\*



Chevron Grid - Up to 300 Contacts in 6 Rows.



Staggered Grid - Up to 360 Contacts in 8 Rows.



GEN-X Grid - Up to 472 Contacts in 8 Rows.

| APPLICATION  | STANDARDS/ REQUIREMENTS   | COUPLING/ MOUNTING  | CONTACT TERMINATION/ ARRANGEMENTS   | PERFORMANCE ENVIRON./ELECT.  |
|--|---|---|---|--|
| Line replaceable modular interconnects with very high contact densities, for attachment to printed circuit boards. Contain Bristle Brush contacts, consisting of multiple strands of high tensile strength wire that are bundled together to form a "brush-like" contact. LRM connectors are available in SEM-E and custom form formats. | Uses Bristle Brush contact which meets MIL-DTL-55302. Amphenol staggered grid LRM connector is the F-22 Avionics system connector choice. | <b>Modules:</b> Surface mount/Straddle mount with .0375 spacing between leads, with rows of leads on each side of the module. Can be centered or off-centered mounted. <b>Backplanes:</b> Available with through-hole solder posts or with compliant pins. <b>Polarization:</b> Insert arrangement controls mating orientation. Up to 4096 keying combinations. | <b>Brush contact termination.</b> <b>Chevron Grid:</b> Backplane termination: PCB through-hole solder. <b>Module/LRM termination:</b> Surface mount on 0.025 pitch. <b>Staggered Grid:</b> Backplane termination: PCB through-hole solder or solderless compliant into 0.025 plated-through holes. <b>Module/LRM termination:</b> Surface mount on 0.025 pitch to flex circuit. <b>GEN-X Grid:</b> Backplane termination: PCB through-hole solder or solderless compliant into 0.025 plated-through holes. <b>Module/LRM termination:</b> Surface mount on 0.0375 pitch to rigid flex circuit boards. | Operating temp. from -65°C to +125°C. Suitable for vapor phase soldering. Connector bodies are aluminum alloy with electroless nickel finish. Superior performance under vibration. Connector configurations are capable of supporting data rates in excess of 1 Gbps. Staggered and GEN-X styles are standard with ESD protection - see below.<br><br>Bristle Brush contacts provide: <ul style="list-style-type: none"> <li>• Low mating/unmating forces - 70% to 90% reduction from conventional pin and socket contacts.</li> <li>• Proven durability and long contact life - over 20,000 cycles of mating and unmating without performance degradation.</li> <li>• Multiple points (14-17) of contact per mated contact.</li> <li>• Intermittency-free performance.</li> <li>• Redundant current paths (stable, low resistance).</li> <li>• Proven electrical and gas tight contact sites.</li> </ul> |

Variety of Rectangular Interconnection Products, including LRMs and Low Mating Force Brush Connectors. Also shows the OBIS, Optic-Electric Backplane.

#### OPTIONAL FEATURES

- Wide range of combinations available for PCB/heat sink accommodations.
- Ruggedized VME64-X is another LRM type connector - See next page.
- Hybrid arrangements with Brush contacts, coaxial, power and fiber optics are available in the Staggered grid style.

#### MARKETS

- All markets of Rectangular Low Mating Force Connectors, as shown above.

#### MARKETS

- Military and Commercial Aviation
- Military Vehicles and GPS Systems

III 38999  
II  
I SJT

26482  
Matrix 2

83723 III  
Matrix Pyle

5015  
Crimp Rear Release Matrix

26500 Pyle

Printed  
Circuit Board

EMI Filter  
Transient

Fiber Optics

High Speed  
Contacts

Options  
Others



38999  
SJT I II III

26482  
Matrix 2

83723 III  
Matrix Pyle

5015  
Crimp Rear Release Matrix

26500 Pyle

Printed  
Circuit Board

EMI Filter  
Transient

Fiber Optics

High Speed  
Contacts

Options  
Others

### LRM Connectors with ESD Protection

Reference Catalog 12-037\*



| APPLICATION  | STANDARDS/ REQUIREMENTS  | COUPLING/ MOUNTING  | CONTACT TERMINATION/ ARRANGEMENTS                     | PERFORMANCE ENVIRON./ELECT.   |
|--|--|---|---|---|
| Staggered style and GEN-X style are standard with ESD protection. These connectors utilize the Faraday cage principal to shunt electrostatic discharge events to the conductive enclosure on which the connector is mounted, thus never allowing the high voltage, high current discharge event to reside on any contacts. | Exceeds protection requirements of IEC 801-2 and MIL-STD-1686. | LRM connectors with the added feature of ESD protection eliminate the need for discrete components (such as diodes) and maximizes PC board real estate. | See termination information for LRM connectors above. | Ensures that all components within a conductive enclosure will be subjected to a max. of 20V during electrostatic discharges between -26 KV and +26 KV. Response time is instantaneous. No capacitive loading of signal contacts. The ESD protection is provided on the module/LRM connector in the unmated condition, making it ideal for Level 2 maintenance. |

#### OPTIONAL FEATURES

- (Also see ESD protection in MIL-DTL-38999 Series III connectors - Filter/Transient Protection section. Consult Amphenol for further information.)

#### MARKETS

- Military and Commercial Aviation
- Military Vehicles and GPS Systems

### LRM Surface Mount Connectors with Fiber Optics, RF Modules, Power Supply Modules

Reference 12-037\*



LRM with Fiber Optics



RF Modules

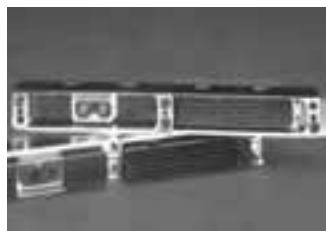

Power Supply Modules

| APPLICATION  | STANDARDS/ REQUIREMENTS   | COUPLING/ MOUNTING                                  | CONTACT TERMINATION/ ARRANGEMENTS   | PERFORMANCE ENVIRON./ELECT.  |
|--|---|---|---|--|
| Line replaceable modular interconnects with very high contact densities, for attachment to printed circuit boards. Offers versatility of combining contact types within modules - fiber optics, shielded RF coax, and power contacts one high density package. | High performance LRM connectors with hybrid contact arrangements available. | Same as for LRM connectors shown on preceding page. | Combinations of: <ul style="list-style-type: none"> <li>• Brush contacts</li> <li>• <u>Fiber Optic LRM</u> - MIL-T-29504 type termini or MT ferrules (2-24 fiber lines per ferrule)</li> <li>• <u>RF Modules</u> with coax contacts - size 16 M39029 type, size 12 for DC-2 GHz or size 8 for DC-32 GHz. Other RF contacts can be accommodated.</li> <li>• <u>Power Supply Modules</u> with custom 270VDC sections utilizing size 22D crimp or compliant pin contacts. Crimp termination size 16, 12 and 8 contacts for high current applications.</li> </ul> | Connector performances and brush contact performances are the same as shown on preceding page for LRM connectors. Power supply modules with 270VDC sections are capable of providing corona-free operation at 75,000 ft. |

#### OPTIONAL FEATURES

- Digital/Brush contact inserts can be partially populated to permit high voltage carrying capacity through the electrical PWB, while isolating sensitive electrical signals.
- Differential pair inserts have been specifically designed to support data rates with excess of 1.2 Gbps.
- Also see page 40 for optical backplane interconnection system, that can provide up to 192 fiber optic lines and 80 digital contacts in SEM-E format.

#### MARKETS

- Military and Commercial Aviation
- Military Vehicles
- GPS Systems

\*Amphenol is developing a combined rectangular catalog 12-R1. 12-035,12-037 and LM-300 will be included in the combined rectangular catalog please contact Amphenol Aerospace for future availability.

# Rectangular Interconnects

## For a Wide Range of Applications, Military

### Pyle LMS Modular Connectors

Reference Pyle Bulletin LM-300\*

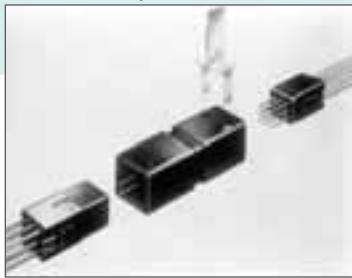

| APPLICATION   | STANDARDS/ REQUIREMENTS     | COUPLING/ MOUNTING   | CONTACT TERMINATION/ ARRANGEMENTS      | PERFORMANCE ENVIRON./ELECT.           |
|---|-----------------------------|--|--|---------------------------------------|
| In-line splice connectors - simple, low cost interconnection devices that incorporate LMD modules and contacts. | Supplements the LMD family. | 3-piece assembly with 2 styles - standard requiring removal tool, or style with a push button release. Bracket available for panel mounting. | Uses modules common to LMD connectors. | Operating temp. from -55°C to +140°C. |

#### OPTIONAL FEATURES

- Panel mounting bracket available or tie straps.
- Module removal tool available for standard splice style.

#### MARKETS

- Instrumentation and Testing Equipment

### Pyle LMD Modular Connectors

Reference Pyle Bulletin LM-300\*



| APPLICATION  | STANDARDS/ REQUIREMENTS  | COUPLING/ MOUNTING  | CONTACT TERMINATION/ ARRANGEMENTS                             | PERFORMANCE ENVIRON./ELECT.  |
|--|--|---|---|--|
| Rectangular interconnects comprised of housings, modules and contacts, designed to provide flexibility in the assembly of wire harnesses. For attachment to PC boards. Also designs for rack & panel or cable to cable attachment. | Designed for wire harness terminations and to eliminate costly PC board and associated hardware. | <u>Linear module design</u> - for rack & panel or cable to cable applications. <u>Bussing modules</u> - allow for a plurality of circuit networks without extra hardware. <u>Diode modules</u> - sealed for protection; eliminate need for PC boards/ hardware. <u>Relay modules</u> - sealed or unsealed; eliminate need for PC boards/hardware. | Modules incorporate crimp contacts in sizes 8, 16, 20 and 22. | Operating temp. from -55°C to +140°C. Durability: 250 cycles mating and unmating. Module insertion and removal force: 5 lbs. max. Housings, modules and contacts are all ordered separately and require assembly with appropriate LMD accessory tools. Housings of black thermoplastic are U/L rated 94VO flame retardant. Housings of white thermoplastic provide increased resistance to industrial oils and solvents. |

#### OPTIONAL FEATURES

- Variety of module options provide a mix of both active and passive devices within one connector.
- Modules offered either environmentally sealed or unsealed.
- Standard design - housings with 6 bays with choice of four module contact arrangements: 1 #8, 4 #16, 9 #20, 16 #22. PC tail contacts also available.
- Housing material options: black or white thermoplastic.
- Plug and receptacle housings may be front or rear panel mounted.
- Optional keying post provides six position keying capability.
- Optional center jackscrew available for ease of mating and unmating and high reliability under vibration.
- Two types of cable strain reliefs - for either internal or external attachment.

#### MARKETS

- Instrumentation and Avionics Controls

### VME P0/J0 MT Connectors with Fiber Optics

Reference 12-037\*



| APPLICATION  | STANDARDS/ REQUIREMENTS                | COUPLING/ MOUNTING   | CONTACT TERMINATION/ ARRANGEMENTS                     | PERFORMANCE ENVIRON./ELECT.  |
|--|--|--|---|--|
| For attachment to VME-64X printed circuit board and cards where fiber optics is required. Used in place of P0/J0 electrical applicable connectors. | Tested to IEEE 1156.1-1993 paragraphs. | Mount to standard VME64X cards and backplanes in the P0/J0 location. | Uses fiber optic "MT" ferrules in the P0/J0 location. | Operating temp. from -55°C to +125°C. Shock: 100g, 6ms, 1/2 sine, 18 pulses<br>Shock: 30g, 6ms, 1/2 sine, 18 pulses<br>Sine Vibration: 10g, 40 min/axis, 3 axis<br>Random Vibration: 0.15g <sup>2</sup> Hz, 40 min/axis, 3 axis<br>ESD: 15 KV/150 pF |

#### OPTIONAL FEATURES

- Designed to customer specifications.

#### MARKETS

- Military and Commercial Aviation
- Military Vehicles
- GPS Systems

\*Amphenol is developing a combined rectangular catalog 12-R1. 12-035, 12-037 and LM-300 will be included in the combined rectangular catalog please contact Amphenol Aerospace for future availability.

III  
II  
I  
SJT  
38999

Matrix 2  
26482

Matrix  
Pyle  
83723 III

Crimp Rear  
Release Matrix  
5015

Pyle  
26500

Printed  
Circuit Board

EMI Filter  
Transient

Fiber Optics

High Speed  
Contacts

Options  
Others



Компания «ЭлектроПласт» предлагает заключение долгосрочных отношений при поставках импортных электронных компонентов на взаимовыгодных условиях!

Наши преимущества:

- Оперативные поставки широкого спектра электронных компонентов отечественного и импортного производства напрямую от производителей и с крупнейших мировых складов;
- Поставка более 17-ти миллионов наименований электронных компонентов;
- Поставка сложных, дефицитных, либо снятых с производства позиций;
- Оперативные сроки поставки под заказ (от 5 рабочих дней);
- Экспресс доставка в любую точку России;
- Техническая поддержка проекта, помощь в подборе аналогов, поставка прототипов;
- Система менеджмента качества сертифицирована по Международному стандарту ISO 9001;
- Лицензия ФСБ на осуществление работ с использованием сведений, составляющих государственную тайну;
- Поставка специализированных компонентов (Xilinx, Altera, Analog Devices, Intersil, Interpoint, Microsemi, Aeroflex, Peregrine, Syfer, Eurofarad, Texas Instrument, Miteq, Cobham, E2V, MA-COM, Hittite, Mini-Circuits, General Dynamics и др.);

Помимо этого, одним из направлений компании «ЭлектроПласт» является направление «Источники питания». Мы предлагаем Вам помощь Конструкторского отдела:

- Подбор оптимального решения, техническое обоснование при выборе компонента;
- Подбор аналогов;
- Консультации по применению компонента;
- Поставка образцов и прототипов;
- Техническая поддержка проекта;
- Защита от снятия компонента с производства.



#### Как с нами связаться

**Телефон:** 8 (812) 309 58 32 (многоканальный)

**Факс:** 8 (812) 320-02-42

**Электронная почта:** [org@eplast1.ru](mailto:org@eplast1.ru)

**Адрес:** 198099, г. Санкт-Петербург, ул. Калинина, дом 2, корпус 4, литера А.