



FCIconnect.com

Copyright FCI.

List of "HFW\_\_R-1/2STZE1LF" customer document

DOCUMENT NO.	LIST
SC-HFWR04	SPEC.
JSA96791	CAT NO.TABLE FOR 1mm SPACING SMT CONNECTOR (HFW__R-1/2STZ__LF)
JSA96792	1mm SPACING SURFACE MOUNT FPC CONNECCTOR (HFW__R-1STZ__LF)
JSA96793	1mm SPACING SURFACE MOUNT FPC CONNECCTOR (HFW__R-2STZ__LF)
JSA96794	CAT.NO.TABLE FOR PLASTIC TAPE PACKAGED 1mm SPACING SMT CONN.(HFW__R-1/2STZE1LF)
JSA96795	1mm SPACING SMT CONNECTOR (HFW__R-1STZE1LF)
JSA96796	1mm SPACING SMT CONNECTOR (HFW__R-2STZE1LF)
JSA93573	RECOMMENDED CABLE (FPC) (HFW__R-1/2_____)
JSA93574	RECOMMENDED CABLE (FFC) (HFW__R-1/2_____)
BJM-HFWR101	HANDLING PROCEDURES

mat'l. code		surface 58/ISO 1302 ✓		tolerance ISO 406 ISO 1101		projection		product family 58NF		CODE JP	
ltr	ecn no	dr	date	tolerances unless otherwise specified		mm		title			
A	J05-0653	H.T	10/12/05	angles	linear			1mm SPACING FPC/FFC CONNECTOR DOCUMENT LIST			
B	J06-0413	H.T	10/4/06			scale X		(Cat. No. : HFW__R-1/2STZE1LF)			
		dr	10/14/06					dwg no		sheet 1 of 1 size	
		enr	10/10/06					JSA 96790		A4	
		chr	10/12/06					type		Product Customer Drawing	
		appd	10/12/06								
sheet index	revision sheet	B	1							Rev. B	

CAT. NO. & DIMENSIONS

(NOTE3)	NO. OF CONTACTS (n)	CAT. NO.	DIMENSIONS (NOTE2)		
			A ± 0.2	B ± 0.2	C ± 0.1
	4	HFW4R-1/2STZ__LF	6.6	3	5.14
	5	HFW5R-1/2STZ__LF	7.6	4	6.14
	6	HFW6R-1/2STZ__LF	8.6	5	7.14
	7	HFW7R-1/2STZ__LF	9.6	6	8.14
	8	HFW8R-1/2STZ__LF	10.6	7	9.14
	9	HFW9R-1/2STZ__LF	11.6	8	10.14
	10	HFW10R-1/2STZ__LF	12.6	9	11.14
	11	HFW11R-1/2STZ__LF	13.6	10	12.14
	12	HFW12R-1/2STZ__LF	14.6	11	13.14
	13	HFW13R-1/2STZ__LF	15.6	12	14.14
	14	HFW14R-1/2STZ__LF	16.6	13	15.14
	15	HFW15R-1/2STZ__LF	17.6	14	16.14
	16	HFW16R-1/2STZ__LF	18.6	15	17.14
	17	HFW17R-1/2STZ__LF	19.6	16	18.14
	18	HFW18R-1/2STZ__LF	20.6	17	19.14
	19	HFW19R-1/2STZ__LF	21.6	18	20.14
	20	HFW20R-1/2STZ__LF	22.6	19	21.14
	21	HFW21R-1/2STZ__LF	23.6	20	22.14
	22	HFW22R-1/2STZ__LF	24.6	21	23.14
	23	HFW23R-1/2STZ__LF	25.6	22	24.14
	24	HFW24R-1/2STZ__LF	26.6	23	25.14
	25	HFW25R-1/2STZ__LF	27.6	24	26.14
	26	HFW26R-1/2STZ__LF	28.6	25	27.14
	27	HFW27R-1/2STZ__LF	29.6	26	28.14
*	28	HFW28R-1/2STZ__LF	30.6	27	29.14
*	29	HFW29R-1/2STZ__LF	31.6	28	30.14
	30	HFW30R-1/2STZ__LF	32.6	29	31.14

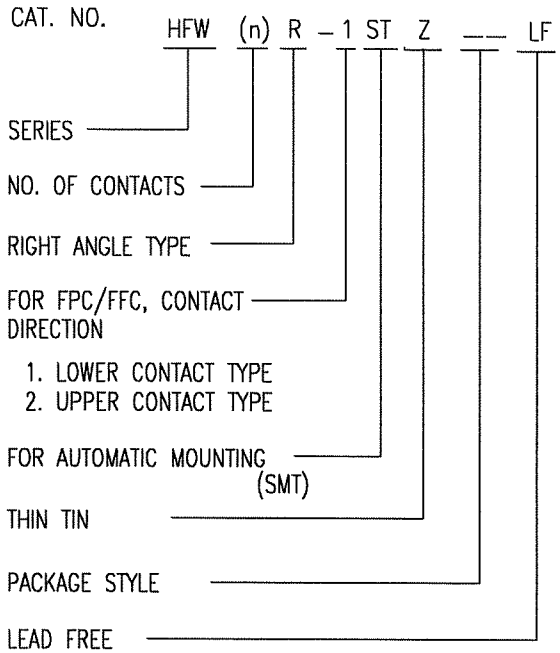

NOTES

1. THIS PRODUCT IS THE CONNECTOR DESIGNED TO TERMINATE FPC AND COPES WITH AUTOMATIC MOUNTING (SMT).
2. SEE PART DRAWINGS FOR DIMENSIONS A~C.
3. PLEASE CONSULT US IN CASE OF USING PARTS WITH \* MARK.

mat'l. code				surface 58 / ISO 1302 ✓	tolerance ISO 406 / ISO 1101	projection	product family 58NF	CODE JP
ltr	ecn no	dr	date	tolerances unless otherwise specified		mm	title	
A	J05-0653	H.T	10/12/05	angles	linear		CAT NO.TABLE FOR 1mm SPACING SMT CONNECTOR (Cat.No. HFW__R-1/2STZ__LF)	
B	J06-0413	H.T	10/4/06			scale X	dwg no sheet 1 of 1 size	
				dr	10/4/06	FCJ	JSA 96791 A4	
				engr	10/4/06		type Product Customer Drawing	
				chr	10/12/06			
				appd	10/11/06			
sheet index	revision B	sheet 1						Rev. B

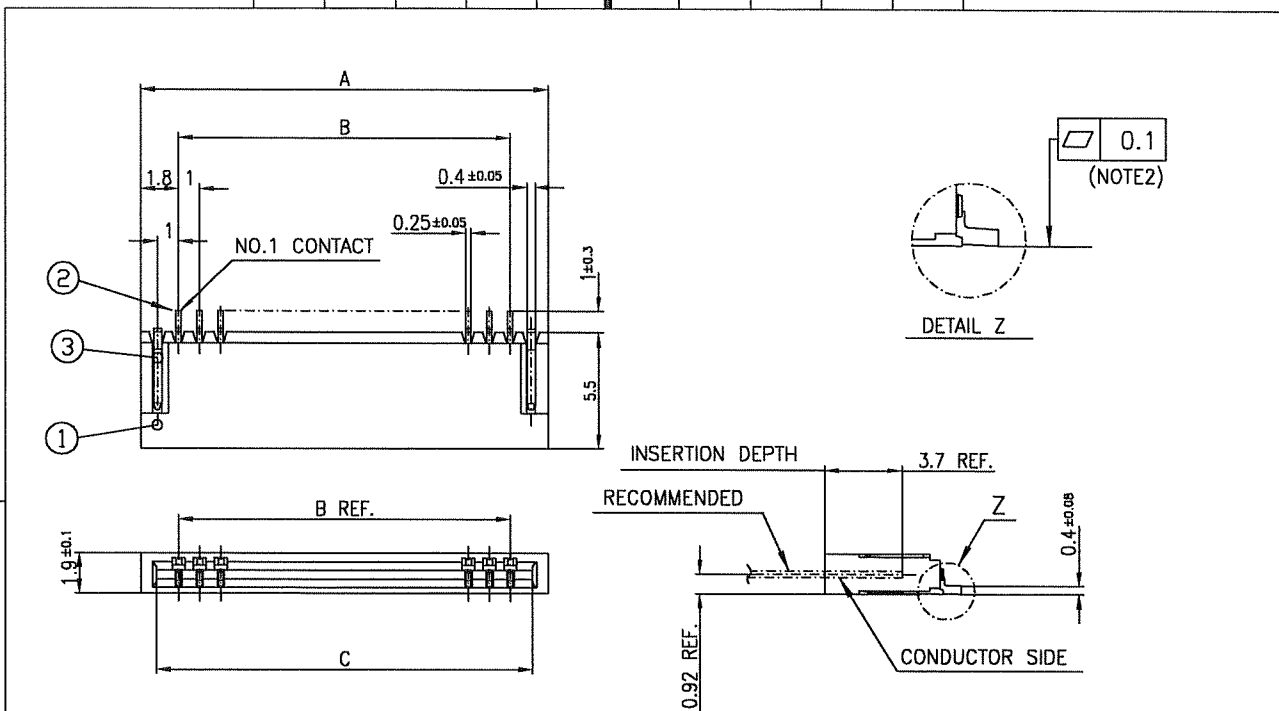

PT. NO.	PARTS NAME	MATERIAL	Q'TY	NOTE
1	HOUSING	PA6T RESIN GLASS REINFORCED (UL94V-0)	1	COLOR:BLACK
2	CONTACT	PHOSPHOR BRONZE	n	CONTACT POINT:THIN TIN
3	MOUNTING PLATE		2	TIN

n : NO. OF CONTACTS

RECOMMENDED PC BOARD LAYOUT (COMPONENT SIDE)

BASIC PATTERN

NO.1 CONTACT POSITION

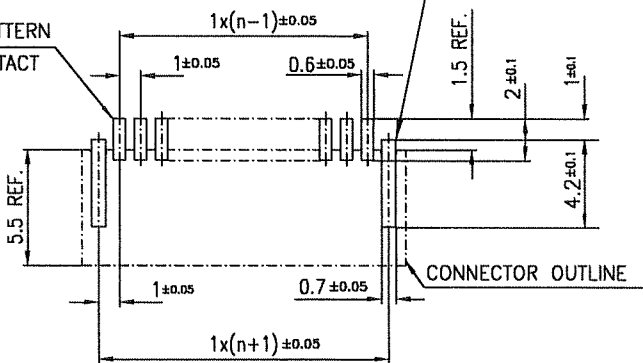

NOTES

1. THIS PRODUCT IS THE CONNECTOR DESIGNED TO TERMINATE FPC AND COPES WITH AUTOMATIC MOUNTING (SMT).
2. FLATNESS OF CONTACT TERMINAL FOR HOUSING MUST BE WITHIN TOLERANCE IN Z PORTION DETAILED DRAWING.
3. THIS PRODUCT IS LOWER CONTACT TYPE CONNECTOR.
4. THIS PRODUCT MEETS EUROPEAN UNION DIRECTIVES AND OTHER COUNTRY REGULATIONS AS DESCRIBED IN GS-22-008
5. THE HOUSING WILL WITHSTAND EXPOSURE TO 260°C PEAK TEMPERATURE FOR 10 SECONDS IN A REFLOW SOLDERING OVEN

mat'l. code		surface 5B / ISO 1302 ✓		tolerance ISO 406 / ISO 1101		projection		product family 58NF		CODE JP	
ltr	ecn no	dr	date	tolerances unless otherwise specified		mm		title			
A	J05-0653	H.T	10/12/05	angles	linear	±0.2		1mm SPACING SURFACE MOUNT FPC CONNECTOR (Cat.No. HFW__R-1STZ__LF)			
B	J06-0413	H.T	10/4/06			scale X		dwg no sheet 1 of 1 size			
				dr	10/4/06			JSA 96792 A4			
				enrg	10/4/06			type Product Customer Drawing			
				chr	10/12/06						
				appd	10/12/06						
sheet index	revision sheet	B	1							Rev. B	

SC-HFWR 04 JSA96791 form: A4

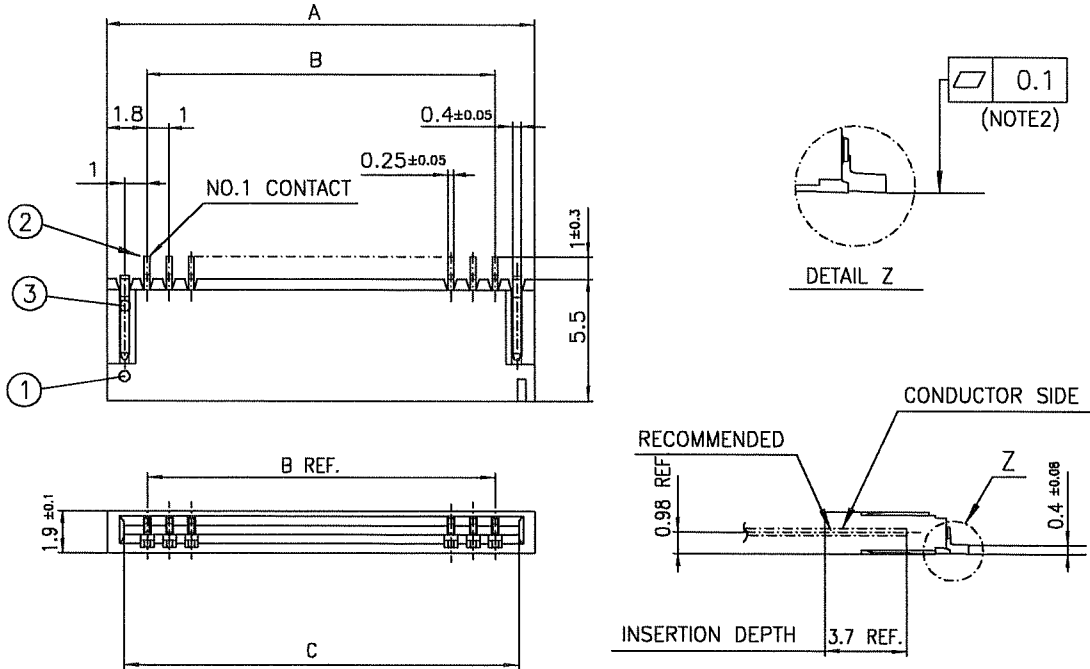

PT. NO.	PARTS NAME	MATERIAL	Q'TY	NOTE
1	HOUSING	PA6T RESIN GLASS REINFORCED (UL94V-0)	1	COLOR:BLACK
2	CONTACT	PHOSPHOR BRONZE	n	CONTACT POINT:THIN TIN
3	MOUNTING PLATE		2	TIN

n : NO. OF CONTACTS

RECOMMENDED PC BOARD LAYOUT (COMPONENT SIDE)

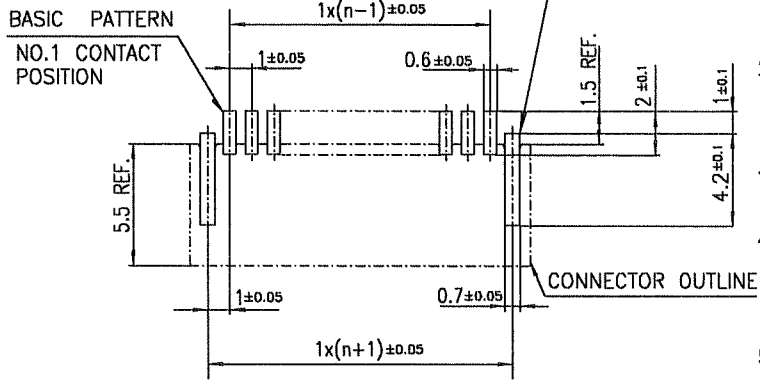

PATTERN FOR MOUNTING PLATE FIXING

- NOTES
1. THIS PRODUCT IS THE CONNECTOR DESIGNED TO TERMINATE FPC AND COPES WITH AUTOMATIC MOUNTING (SMT).
  2. FLATNESS OF CONTACT TERMINAL FOR HOUSING MUST BE WITHIN TOLERANCE IN Z PORTION DETAILED DRAWING.
  3. THIS PRODUCT IS UPPER CONTACT TYPE CONNECTOR.
  4. THIS PRODUCT MEETS EUROPEAN UNION DIRECTIVES AND OTHER COUNTRY REGULATIONS AS DESCRIBED IN GS-22-008
  5. THE HOUSING WILL WITHSTAND EXPOSURE TO 260°C PEAK TEMPERATURE FOR 10 SECONDS IN A REFLOW SOLDERING OVEN

mat'l. code				surface 58 / tolerance ISO 1302 ✓ ISO 406 ISO 1101		projection		product family 58NF		CODE JP	
ltr	ecn no	dr	date	tolerances unless otherwise specified		mm		title			
A	J05-0653	H.T	10/12/'05	±0.2		mm		1mm SPACING SURFACE MOUNT FPC CONNECTOR (Cat.No. HFWR__R-2STZ__LF)			
B	J06-0413	H.T	10/4/'06	angles	linear	scale X		dwg no		sheet 1 of 1 size	
				dr	10/14/06	FCJ		JSA 96793		A4	
				enr	10/16/06			type		Product Customer Drawing	
				chr	10/12/06						
				appd	10/12/06						
sheet index	revision sheet	B	1							Rev. B	

SC-HFWR 04 JSA96791 form: A4

CAT. NO. & DIMENSIONS

(NOTE4)	NO. OF CONTACTS (n)	CAT. NO. (NOTE2)	DIMENSIONS (NOTE3)		
			E ± 0.5	F ± 0.3	G ± 0.1
	4	HFW4R-1/2STZE1LF	28.4	24	—
	5	HFW5R-1/2STZE1LF	28.4	24	—
	6	HFW6R-1/2STZE1LF	28.4	24	—
	7	HFW7R-1/2STZE1LF	28.4	24	—
	8	HFW8R-1/2STZE1LF	28.4	24	—
	9	HFW9R-1/2STZE1LF	28.4	24	—
	10	HFW10R-1/2STZE1LF	28.4	24	—
	11	HFW11R-1/2STZE1LF	28.4	24	—
	12	HFW12R-1/2STZE1LF	28.4	24	—
	13	HFW13R-1/2STZE1LF	28.4	24	—
	14	HFW14R-1/2STZE1LF	28.4	24	—
	15	HFW15R-1/2STZE1LF	36.4	32	28.4
	16	HFW16R-1/2STZE1LF	36.4	32	28.4
	17	HFW17R-1/2STZE1LF	36.4	32	28.4
	18	HFW18R-1/2STZE1LF	36.4	32	28.4
	19	HFW19R-1/2STZE1LF	48.4	44	40.4
	20	HFW20R-1/2STZE1LF	48.4	44	40.4
	21	HFW21R-1/2STZE1LF	48.4	44	40.4
	22	HFW22R-1/2STZE1LF	48.4	44	40.4
	23	HFW23R-1/2STZE1LF	48.4	44	40.4
	24	HFW24R-1/2STZE1LF	48.4	44	40.4
	25	HFW25R-1/2STZE1LF	48.4	44	40.4
	26	HFW26R-1/2STZE1LF	48.4	44	40.4
	27	HFW27R-1/2STZE1LF	48.4	44	40.4
*	28	HFW28R-1/2STZE1LF	48.4	44	40.4
*	29	HFW29R-1/2STZE1LF	48.4	44	40.4
	30	HFW30R-1/2STZE1LF	60.4	56	52.4

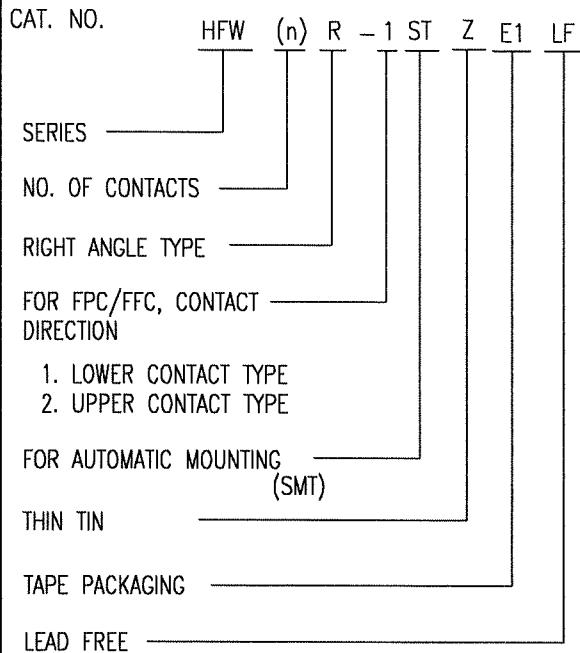

NOTES

1. THIS PRODUCT IS THE CONNECTOR DESIGNED TO TERMINATE FPC AND COPEs WITH AUTOMATIC MOUNTING (SMT).
2. THIS CATALOG NO. INDICATES PLASTIC TAPE PACKAGED CONNECTOR.
3. SEE PART DRAWINGS FOR DIMENSIONS E~G.
4. PLEASE CONSULT US IN CASE OF USING PARTS WITH \* MARK.

mat'l. code		surface 5B / ISO 1302 ✓		tolerance ISO 406 / ISO 1101		projection		product family 58NF		CODE JP	
ltr	ecn no	dr	date	tolerances, unless otherwise specified		mm		title			
A	J05-0653	H.T	10/12/05	angles	linear	mm		CAT. NO. TABLE FOR PLASTIC TAPE PACKAGED 1mm SPACING SMT CONN (Cat.No. HFW__R-1/2STZE1LF)			
B	J06-0413	H.T	10/4/06			scale X		dwg no JSA 96794 sheet 1 of 1 size A4			
				dr	10/4/06	FCJ		type Product Customer Drawing			
				enr	10/4/06						
				chr	10/12/06						
				appd	10/12/06						
sheet index	revision sheet	B	1								Rev. B

SC-HFWR04 JSA96791 form: A4



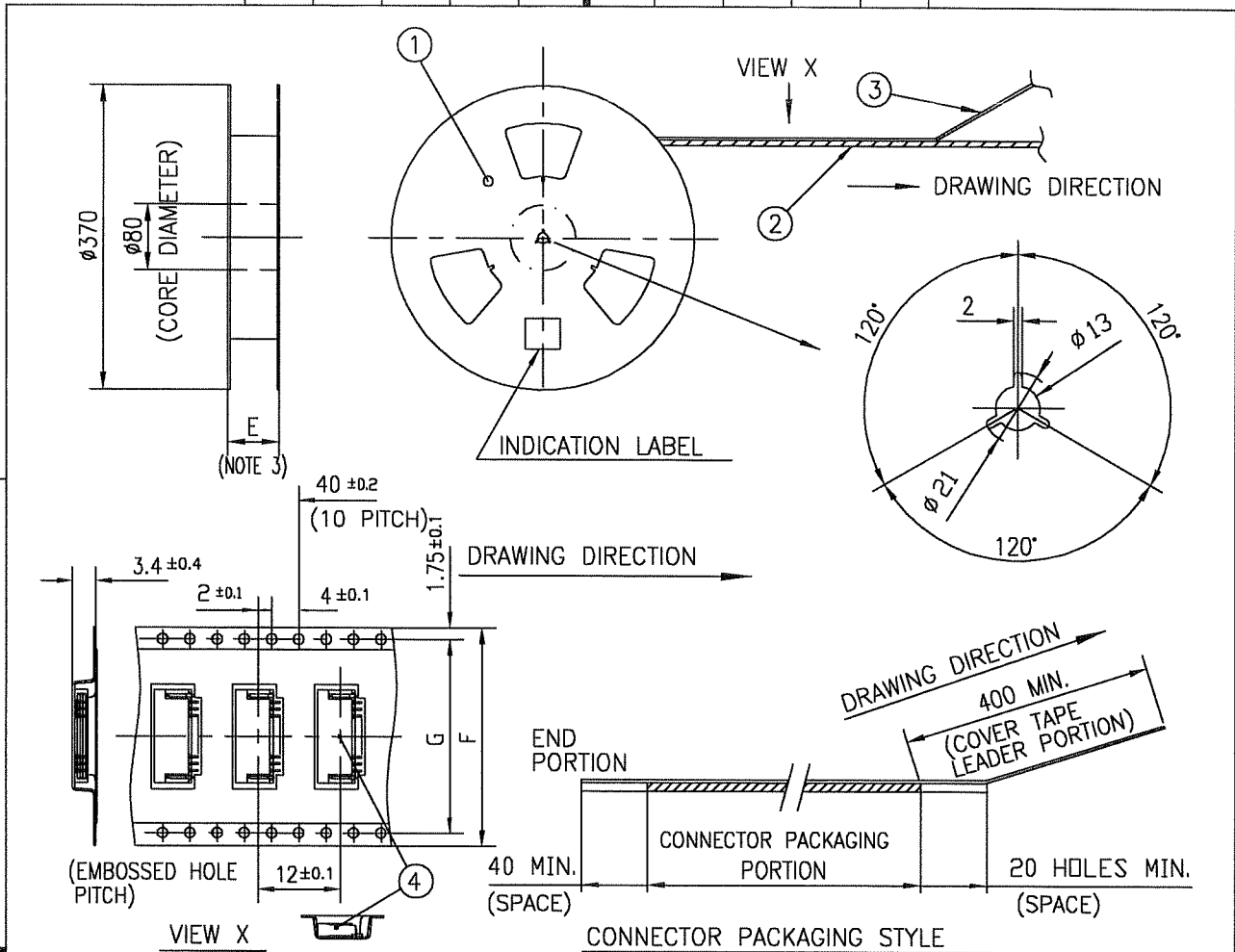

PT. NO.	PARTS NAME	CAT. NO.	MATERIAL	Q'TY	NOTE
1	REEL	—	CARDBOARD	1	COLOR:WHITE
2	PLASTIC (EMBOSSD) TAPE	—	PET	—	COLOR:TRANSPARENCY
3	COVER	—	POLYESTER	—	COLOR:TRANSPARENCY
4	CONNECTOR	HFWR__R-1STZ__LF	SEE ATTACHED DWG.	2000	LOWER CONTACT TYPE

NOTES

1. THIS IS PLASTIC TAPE PACKAGED CONNECTOR DESIGNED TO TERMINATE FPC AND COPEs WITH AUTOMATIC MOUNTING (SMT).
2. SEE JIS C 0806 (PACKING OF ELECTRONIC COMPONENTS ON CONTINUOUS TAPES (SURFACE MOUNTING DEVICES)) FOR SHAPE AND DIMENSIONS OF PLASTIC (EMBOSSD) TAPE AND REEL.
3. E DIMENSION IS PORTION OF THE CORE.

mat'l. code		surface 58 / ISO 1302 ✓		tolerance ISO 406 / ISO 1101		projection		product family 58NF		CODE JP	
ltr		ecn no		dr		date		tolerances, unless otherwise specified		title	
A		J05-0653		H.T		10/12/05		±5		1mm SPACING SMT CONNECTOR	
B		J06-0413		H.T		10/4/06		mm		(Cat.No. HFWR__R-1STZE1LF)	
								scale X		dwg no	
								FCJ		sheet 1 of 1	
										JSA 96795	
										size A4	
										type Product Customer Drawing	
sheet index		revision sheet		B		1				Rev. B	

SC-HFWR 04 JSA96791 form: A4



FCIconnect.com

Copyright FCI.

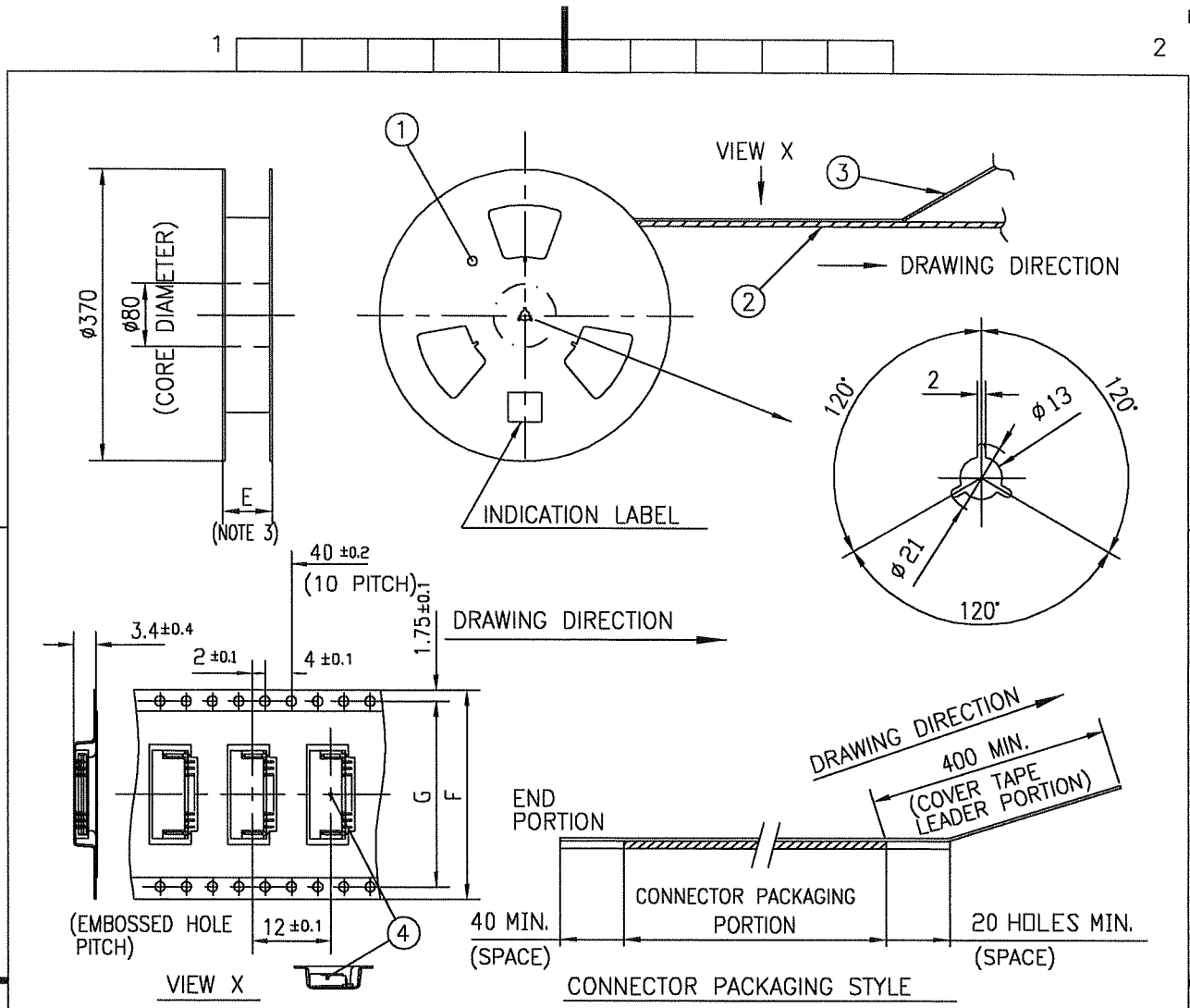

PT. NO.	PARTS NAME	CAT. NO.	MATERIAL	Q'TY	NOTE
1	REEL	---	CARDBOARD	1	COLOR:WHITE
2	PLASTIC (EMBOSSED) TAPE	---	PET	---	COLOR:TRANSPARENCY
3	COVER	---	POLYESTER	---	COLOR:TRANSPARENCY
4	CONNECTOR	HFWR__R-2STZ__-LF	SEE ATTACHED DWG.	2000	UPPER CONTACT TYPE

NOTES

1. THIS IS PLASTIC TAPE PACKAGED CONNECTOR DESIGNED TO TERMINATE FPC AND COPES WITH AUTOMATIC MOUNTING (SMT).
2. SEE JIS C 0806 (PACKING OF ELECTRONIC COMPONENTS ON CONTINUOUS TAPES (SURFACE MOUNTING DEVICES)) FOR SHAPE AND DIMENSIONS OF PLASTIC (EMBOSSED) TAPE AND REEL.
3. E DIMENSION IS PORTION OF THE CORE.

mat'l. code		surface 58 / tolerance ISO 1302 ✓		tolerance ISO 406 / ISO 1101		projection		product family 58NF		CODE JP	
ltr	ecn no	dr	date	tolerances unless otherwise specified		mm		title			
A	J05-0853	H.T	10/12/'05	angles	linear	mm		1mm SPACING SMT CONNECTOR (Cat.No. HFWR__R-2STZE1LF)			
B	J06-0413	H.T	10/4/'06	±5'		scale X		dwg no sheet 1 of 1 size			
				dr	10/14/06			JSA 96796 A4			
			enrg	10/14/06	type Product Customer Drawing						
			chr	10/12/06							
			appd	10/12/06							
sheet index	revision B	sheet 1									Rev. B

SC-HFWR 04 JSA96791 form: A4

RECOMMENDED CABLE (FPC)

n : NO. OF CONDUCTORS

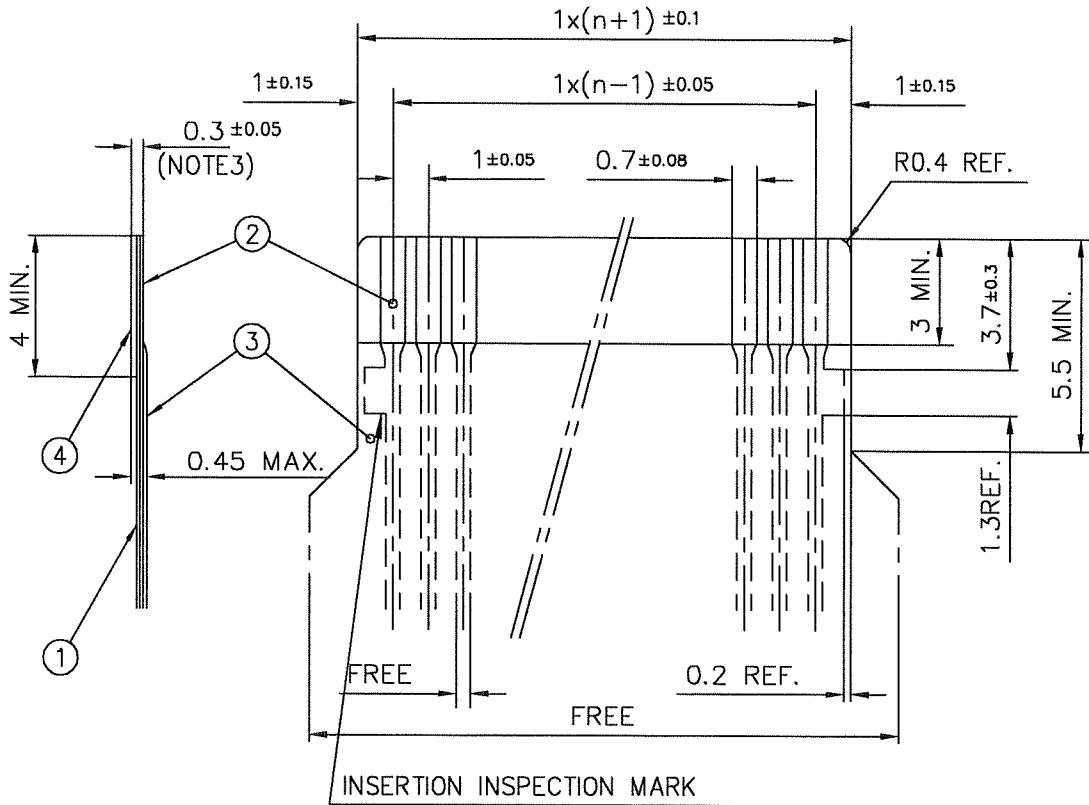

PT. NO.	DESCRIPTION	MATERIAL	THICKNESS ( $\mu\text{m}$ )
1	BASE FILM	POLYIMIDE OR POLYESTER OR EQUIVALENT	25
2	CONDUCTOR	COPPER FOIL(PLATING : SOLDER $1\mu\text{m}$ MIN.)	35
3	OVERLAY	POLYIMIDE OR POLYESTER OR EQUIVALENT	—
4	SUPPORTING TAPE	POLYESTER OR POLYIMIDE OR EQUIVALENT	188

NOTES

1. NO BURR AT EACH PORTION.
2. NO PEELING IN COMMON USE.
3. TOTAL THICKNESS LIMIT OF EACH MATERIAL (INCLUDING ADHESIVE AGENT) IS SPECIFIED.

mat'l. code		surface 58 / tolerance ISO 1302 ✓ / ISO 406 / ISO 1101		projection	product family 58NF	CODE JP
ltr	ecn no	dr	date	tolerances unless otherwise specified		title RECOMMENDED CABLE (Cat. No. HFW__R-1/2__)
A	J06-0413	H.T	10/4/'06	angles	linear	
				mm		dwg no JSA 93573 sheet 1 of 1 size A4
				scale X		
						type Product Customer Drawing
				dr: <i>[Signature]</i> 10/14/06 engr: <i>[Signature]</i> 10/15/06 chr: <i>[Signature]</i> 10/12/06 appd: <i>[Signature]</i> 10/12/06		
sheet index	revision sheet	A	1			Rev. A

form: A4



RECOMMENDED CABLE (FFC)

n : NO. OF CONDUCTORS

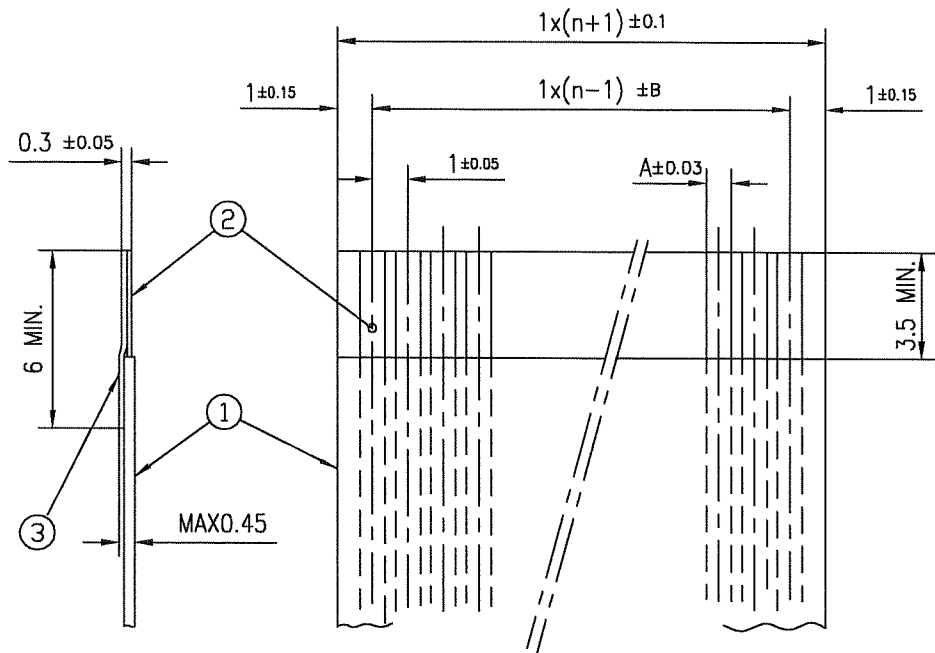

(NOTE 3)	DIMENSION A	TOLERANCE B
1	0.7	0.1
2	0.6	0.07

PT. NO.	DESCRIPTION	MATERIAL	NOTE
1	INSULATOR	FLAME RESISTING POLYESTER OR EQUIVALENT	_____
2	CONDUCTOR	COPPER FOIL	PLATING: TIN OR SOLDER 1µm MIN.
3	SUPPORTING TAPE	FLAME RESISTING POLYESTER OR EQUIVALENT	_____

- NOTES
1. NO BURR AT EACH PORTION.
  2. NO PEELING IN COMMON USE.
  3. BOTH COMBINATION IS ALLOWED.

mat'l. code				surface <sup>58</sup> / tolerance ISO 1302 ✓ / ISO 406 / ISO 1101		projection		product family 58NF		CODE JP	
ltr				ecn no		dr		date		tolerances unless otherwise specified	
1				---		T.M		4/30/'02		angles linear	
A				J06-0413		H.T		10/4/'06		mm	
										scale X	
				dr		<i>[Signature]</i>		10/10/06		title RECOMMENDED CABLE (Cat. No. HFW__R-1/2___) dwg no sheet 1 of 1 size JSA 93574 A4 type Product Customer Drawing	
				enrg		<i>[Signature]</i>		10/10/06			
				chr		<i>[Signature]</i>		10/10/06			
				appd		<i>[Signature]</i>		10/10/06			
sheet index		revision sheet		A		1				Rev. A	



Компания «ЭлектроПласт» предлагает заключение долгосрочных отношений при поставках импортных электронных компонентов на взаимовыгодных условиях!

Наши преимущества:

- Оперативные поставки широкого спектра электронных компонентов отечественного и импортного производства напрямую от производителей и с крупнейших мировых складов;
- Поставка более 17-ти миллионов наименований электронных компонентов;
- Поставка сложных, дефицитных, либо снятых с производства позиций;
- Оперативные сроки поставки под заказ (от 5 рабочих дней);
- Экспресс доставка в любую точку России;
- Техническая поддержка проекта, помощь в подборе аналогов, поставка прототипов;
- Система менеджмента качества сертифицирована по Международному стандарту ISO 9001;
- Лицензия ФСБ на осуществление работ с использованием сведений, составляющих государственную тайну;
- Поставка специализированных компонентов (Xilinx, Altera, Analog Devices, Intersil, Interpoint, Microsemi, Aeroflex, Peregrine, Syfer, Eurofarad, Texas Instrument, Miteq, Cobham, E2V, MA-COM, Hittite, Mini-Circuits, General Dynamics и др.);

Помимо этого, одним из направлений компании «ЭлектроПласт» является направление «Источники питания». Мы предлагаем Вам помощь Конструкторского отдела:

- Подбор оптимального решения, техническое обоснование при выборе компонента;
- Подбор аналогов;
- Консультации по применению компонента;
- Поставка образцов и прототипов;
- Техническая поддержка проекта;
- Защита от снятия компонента с производства.



#### Как с нами связаться

**Телефон:** 8 (812) 309 58 32 (многоканальный)

**Факс:** 8 (812) 320-02-42

**Электронная почта:** [org@eplast1.ru](mailto:org@eplast1.ru)

**Адрес:** 198099, г. Санкт-Петербург, ул. Калинина, дом 2, корпус 4, литера А.