

Amphenol

Amphenol-Tuchel Electronics GmbH

Serie C 146

Schwere Steckverbinder

Series C 146

Heavy duty connectors



Das Unternehmen

Amphenol-Tuchel Electronics GmbH ist ein Unternehmen der US-amerikanischen Amphenol Corporation. Unsere eigenständige globale Präsenz im Hinblick auf Entwicklung, Produktion und Vertrieb ermöglicht es uns, für unsere Kunden außergewöhnliche technische Lösungen und einen optimalen Service zu bieten. Amphenol-Tuchel Electronics GmbH ist seit Jahren ein erfolgreicher Partner seiner Kunden und setzt Maßstäbe in der Verbindungstechnik.

The Company

Amphenol-Tuchel Electronics GmbH is a member of the USA based Amphenol Corporation. With our own global presence we offer our customers exceptional technical support and service in the areas of development, production and distribution. Amphenol-Tuchel Electronics GmbH has a successful history as a partner to our customers and sets standards for connector technology.



Allgemeine Hinweise

Diese Steckverbinder sind in Übereinstimmung mit der Niederspannungsrichtlinie (73/23/EWG) und des Gerätesicherheitsgesetzes entwickelt und gefertigt und entsprechen im besonderen den Normen DIN EN 61984 (VDE 0627); IEC 60664-1 (VDE 0110-1) und IEC 60529.

Die Steckverbinder dürfen nur entsprechend den angegebenen Bemessungsgrößen eingesetzt werden.

Die angegebenen Bemaßungen bei den Montageausschnitten stellen Anhaltswerte dar und sind im konkreten Anwendungsfall auf die Produkte abzustimmen.

Die Überprüfung, ob in speziellen, von uns nicht vorgesehenen Anwendungsbereichen die in diesem Katalog gezeigten Bauelemente anderen als den angegebenen Vorschriften entsprechen, obliegt dem Anwender. Konstruktionsänderungen aufgrund von Qualitätsverbesserungen, Weiterentwicklungen oder Fertigungsforderungen behalten wir uns vor. Mit den Angaben im Katalog werden die Bauelemente spezifiziert, nicht Eigenschaften zugesichert. Weiterverwertung dieser Katalogunterlagen in jeder Form ist nur mit unserer schriftlichen Genehmigung gestattet (URHG, UWG, BGB).







General information

These connectors are designed and produced in conformity with the low voltage directive (73/23/EWG) respectively Gerätesicherheitsgesetz (German law) and are especially in accordance with the standards DIN EN 61984 (VDE0627); IEC 60664-1 (VDE 0110-1) nad IEC 60529.

The connectors may be used only within the technical ratings.

The indicated dimensions with the panel cut-outs represent reference values and are in the concrete application with products to be co-ordinated.

It is the users responsibility to check whether the components illustrated in this catalogue comply with different regulations from those stated in special fields of application which we are unable to foresee. We reserve the right to modify designs in order to improve quality, keep pace with technological advancement or meet particular requirements in production. This catalogue must not be used in any form or manner without our prior approval in writing (Copyright Law, Fair Trading Law, Civil Code).

Inhaltsverzeichnis		Content	Seite/Page	
Bestellnummernsystem / Part No. system			4	
Serie C 146 D		<ul style="list-style-type: none"> • Bemessungsspannung 250 V • Bemessungsstrom 10 A ... 16 A • Anschlussart: crimpen • Kontaktdurchmesser 1,6 mm • Nach DIN EN 175 301 801 (DIN 43652) • Polzahl: 7, 15, 25, 40, 50, 64, 128 	<ul style="list-style-type: none"> • <i>Rated voltage 250 V</i> • <i>Rated current 10 A ... 16 A</i> • <i>Termination: crimp</i> • <i>Contact diameter 1,6 mm</i> • <i>According to DIN EN 175 301 801 (DIN 43652)</i> • <i>Number of contacts: 7, 15, 25, 40, 50, 64, 128</i> 	5
Serie C 146 DD		<ul style="list-style-type: none"> • Polzahl: 24, 42, 72, 108, 216 	<ul style="list-style-type: none"> • <i>Number of contacts: 24, 42, 72, 108, 216</i> 	25
Serie C 146 E		<ul style="list-style-type: none"> • Bemessungsspannung 400 V • Bemessungsstrom 16 A ... 22 A • Anschlussart: vorwiegend schrauben, crimpen • Kontaktdurchmesser 2,5 mm • Polzahl: 6, 10, 16, 24, 48 	<ul style="list-style-type: none"> • <i>Rated voltage 400 V</i> • <i>Rated current 16 A ... 22 A</i> • <i>Termination: mainly screw, crimp</i> • <i>Contact diameter 2,5 mm</i> • <i>Number of contacts: 6, 10, 16, 24, 48</i> 	29
Serie C 146 EE		<ul style="list-style-type: none"> • Polzahl: 10, 18, 32, 46 	<ul style="list-style-type: none"> • <i>Number of contacts: 10, 18, 32, 46</i> 	45
Serie C 146 E/D		Anschlussverteiler	<i>Terminal blocks</i>	49
Serie C 146 E/FE/KO		Steckverbinder mit Eisenkonstantan Kontakten	<i>Connectors with iron-constantan contacts</i>	53
Serie C 146 M		<ul style="list-style-type: none"> • Modular aufgebauter Steckverbinder • Bemessungsspannung 63 - 1000 V • Bemessungsstrom 5 A ... 70 A • Anschlussart: crimpen • Polzahl: 3 - 280 	<ul style="list-style-type: none"> • <i>Modular connector</i> • <i>Rated voltage 63 - 1000 V</i> • <i>Rated current 5 A ... 70 A</i> • <i>Termination: crimp</i> • <i>Number of contacts: 3 - 280</i> 	57
Serie C 146 A		<ul style="list-style-type: none"> • Schmale Bauform • Bemessungsspannung 250 / 400 V • Bemessungsstrom 14 A ... 18 A • Anschlussart: schrauben • Polzahl: 3, 4, 10, 16, 32 	<ul style="list-style-type: none"> • <i>Narrow style</i> • <i>Rated voltage 250 / 400 V</i> • <i>Rated current 14 A ... 18 A</i> • <i>Termination: screw</i> • <i>Number of contacts: 3, 4, 10, 16, 32</i> 	85
Serie C 146 HSE		<ul style="list-style-type: none"> • Bemessungsspannung 400 V • Bemessungsstrom 42 A • Anschlussart: schrauben • Anschlussquerschnitt 6 mm² • Polzahl: 6 	<ul style="list-style-type: none"> • <i>Rated voltage 400 V</i> • <i>Rated current 42 A</i> • <i>Termination: screw</i> • <i>Max. wire gauge 6 mm²</i> • <i>Number of contacts: 6</i> 	93
Serie C 146 HvE		<ul style="list-style-type: none"> • Bemessungsspannung 660 V • Bemessungsstrom 16 A ... 22 A • Anschlussart: schrauben • 2 nacheilende Schaltkontakte • Polzahl: 3, 6, 10, 16, 20, 26, 32 	<ul style="list-style-type: none"> • <i>Rated voltage 660 V</i> • <i>Rated current 16 A ... 22 A</i> • <i>Termination: screw</i> • <i>2 delayed mating contacts</i> • <i>Number of contacts: 3, 6, 10, 16, 20, 26, 32</i> 	97
Serie C 146 S		<ul style="list-style-type: none"> • Bemessungsspannung 125 - 600 V • Bemessungsstrom 10 A ... 70 A • Anschlussart: crimpen, schrauben, löten • Polzahl: 4, 57 	<ul style="list-style-type: none"> • <i>Rated voltage 125 - 600 V</i> • <i>Rated current 10 A ... 70 A</i> • <i>Termination: crimp, screw, solder</i> • <i>Number of contacts: 4, 57</i> 	105
Gehäuse / Housings			113	
EMV Gehäuse / EMC housings			167	
Zubehör / Accessories			179	
Weitere Informationen/ Additional information				
Maßzeichnungen Kontakte / <i>Drawings of contacts</i>			187	
Sicherheitseinteilung / <i>Safety classification</i>			191	
Allgemeine Technische Informationen / <i>General technical information</i>			192	
Bestellnummernverzeichnis / <i>Summary of Part Numbers</i>			212	

Kontakteinsätze, Gehäuse / Contact inserts, housing

	C146	10A	007	000	2	C
	1)	2)	3)	4)	5)	6)
1)	Serie <i>Series</i>					
2)	Type <i>Type</i>				A = Stifteinsatz / <i>male insert</i> B = Buchseneinsatz / <i>female insert</i> F = Gehäuseunterteil, PG / <i>housing, PG</i> N = Gehäuseunterteil, metrisch / <i>housing, metric</i> G = Gehäuseoberteil, PG / <i>hood, PG</i> R = Gehäuseoberteil, metrisch / <i>hood, metric</i> Z = Schutzdeckel / <i>cover</i>	
3)	Polzahl <i>Number of contacts</i>				z. B. 007 = 7 pol <i>e. g. 007 = 7 contacts</i>	
4)	Ausführungsvariante <i>Design version</i>					
5)	Serie <i>Series</i>				1 = E Serie / <i>E series</i> + FE / KO Serie / <i>FE / KO series</i> 2 = D Serie / <i>D series</i> 3 = HVE Serie / <i>HVE series</i> 4 = A Serie / <i>A series</i> 5 = HSE Serie / <i>HSE series</i> 6 = S Serie / <i>S series</i> 8 = M Serie / <i>M series</i> 9 = DD Serie / <i>DD series</i> 10 = EE Serie / <i>EE series</i>	
6)	Verpackungseinheit <i>Packing unit</i>				X = 10 C = 100 M = 1000	

Kontakte / Contacts

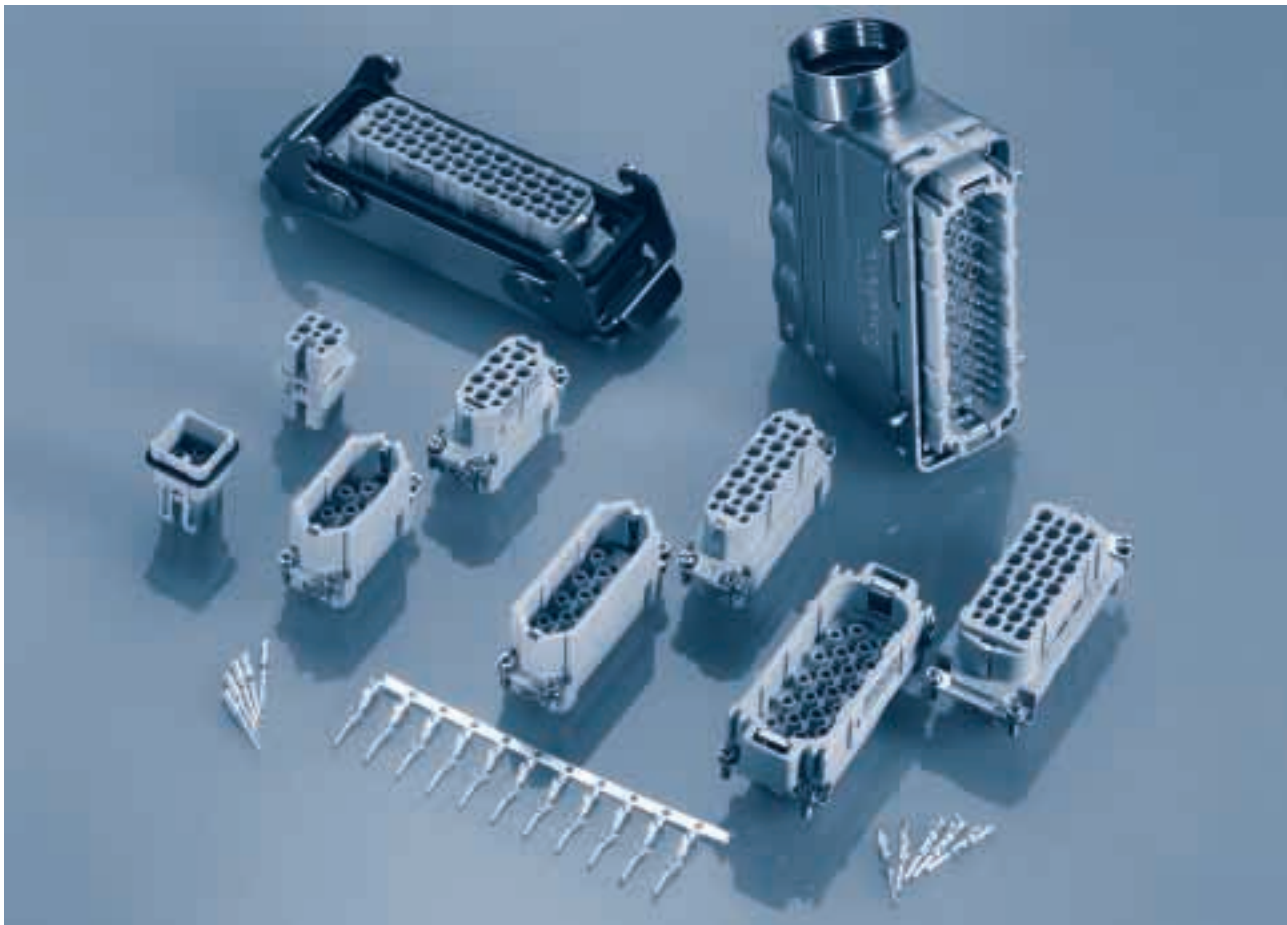

V	N 01	016	0002	(1)
1)	2)	3)	4)	5)
1)	Lieferaussführung: <i>Supplied as:</i>			V = Einzelkontakt 100 Stück <i>Single pack 100 pcs.</i> Z = Bandkontakt mit 100, 200 oder 500 Kontakten <i>Contacts on reel 100, 200 or 500 contacts</i> H = Bandkontakte mit 2000 Kontakten für Crimpmaschinen (Kontaktzuführung rechts) <i>Contacts on reel with 2000 contacts for crimping machines (contact feeding right hand side)</i> T = Bandkontakte mit 2000 Kontakten für Crimpmaschinen (Kontaktzuführung links) <i>Contacts on reel with 2000 contacts for crimping machines (contact feeding left hand side)</i>
2)	Kontaktart: <i>Type of contact:</i>			N 01 = Kontaktstift / <i>male contact</i> N 02 = Kontaktbuchse / <i>female contact</i>
3)	Kontaktgröße <i>Contact size</i>			z. B. 016 = 1,6 mm <i>e. g. 016 = 1,6 mm</i>
4)	Ausführungsvariante <i>Design version</i>			
5)	Oberfläche: <i>Plating:</i>			(1) = versilbert / <i>silver plated</i> (2) = vergoldet (auf Anfrage) / <i>gold plated (upon request)</i>

C 146 D





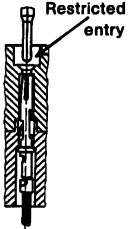
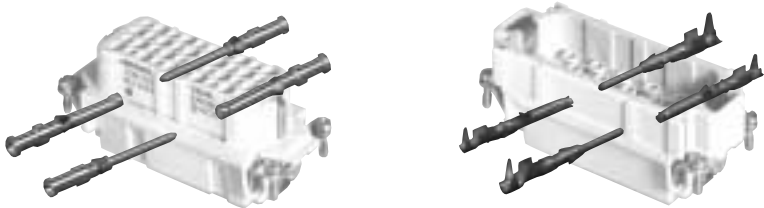
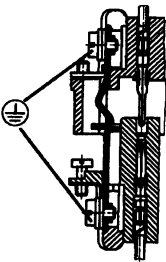

Hauptmerkmale		Main characteristics	
<ul style="list-style-type: none"> • Bemessungsspannung 250 V • Bemessungsstrom 10 A ... 16 A • Anschlussart: crimpen • Kontaktdurchmesser 1,6 mm • nach DIN EN 175 301-801 (DIN 43652) • Polzahl: 7, 15, 25, 40, 50, 64, 128 		<ul style="list-style-type: none"> • Rated voltage 250 V • Rated current 10 A ... 16 A • Termination: crimp • Contact diameter 1,6 mm • According to DIN EN 175 301-801 (DIN 43652) • Number of contacts: 7, 15, 25, 40, 50, 64, 128 	
Zulassungen / Approvals	Prüfstelle / Testhouse	Kennwerte / Characteristics	Zulassungs-Nummer / Approval-No.
SEV		250 V, 10 A	
UL		600 V, 10 A 600 V, 15 A (Hochstrom / High current)	E 63093
CSA		600 V, 10 A	48932
<p>Zulassungen beziehen sich im allgemeinen auf repräsentative Ausführungen der Steckverbinderserie. Prüfumfang und Prüfvorschrift auf Anfrage.</p>		<p><i>In general approvals refer to representative versions of the connector series. Extent and specification of tests upon request.</i></p>	

Kurzinformation
Brief information

<p>Allgemeine Hinweise</p>  <p>General information</p>	<ul style="list-style-type: none"> • Kontakteinsätze ohne Crimpkontakte, Crimpwerkzeuge siehe separater Katalog „Werkzeuge“. • Kontakte müssen separat bestellt werden, Verarbeitungs- und Montagehinweise siehe Katalog „Werkzeuge“. • Für die Einsätze der Serie C 146 D werden die hohen Gehäusebauformen empfohlen. • Steckverbinder der Serie C 146 D dürfen unter Spannung, jedoch nicht unter Strom betätigt werden. Werden die Steckverbinder unter Last gesteckt und getrennt, ist der Strom auf 15 % des Bemessungsstroms zu begrenzen. • Für Kontakteinsätze für gedrehte Kontakte werden Führungsstifte und Führungsbuchsen empfohlen (siehe Seite 184). • Bei Verwendung der Kontakteinsätze mit zwei PE-Anschlüssen ohne Gehäuse ist darauf zu achten, dass jeweils die gegenüberliegenden PE-Anschlüsse miteinander verbunden werden. <p><i>• Contact inserts without crimp contacts, crimping tools see separate catalogue „Tools“.</i></p> <p><i>• Contacts must be ordered separately, processing instructions see catalogue „Tools“.</i></p> <p><i>• We recommend using the high profile housings / hoods for the C146 D inserts.</i></p> <p><i>• Connectors series C146 D may be engaged or disengaged when live but without electrical load.</i></p> <p><i>If these connectors are mated or unmated under load, the load shall be reduced to 15 % of the rated current.</i></p> <p><i>• For contact inserts for turned contacts, guide pins and guide socket are recommended (see page 184).</i></p> <p><i>• By using contact inserts with two PE-connections without hoods, it is necessary to connect the facing of each PE-connection.</i></p>
<p>Genormte Steckverbinder nach DIN EN 175 301 - 801 (DIN 43652)</p> <p>Standardised connectors according to DIN EN 175 301 - 801 (DIN 43652)</p>	<p>Steck- und austauschbar mit allen Fremdfabrikaten nach Norm.</p> <p>a) Kontakteinsatz/Kontakteinsatz 15, 25, 40, 64 pol. b) Kontakteinsatz/Gehäuse 15, 25, 40, 64 pol.</p> <p><i>Interchangeable with all other products which are according to the standard.</i></p> <p><i>a) Contact insert to contact insert 15, 25, 40, 64 way.</i></p> <p><i>b) Contact insert to housing 15, 25, 40, 64 way.</i></p>
<p>Hoher Schutz vor Fehlsteckungen</p> <p>High protection against mismatching</p>	<p>Buchsenkontakteinsatz mit trichterförmiger, verengter Stecköffnung. Hohe Steck- und Kontaktsicherheit mit gestanzten Kontakten.</p> <p><i>Female inserts with funnel shaped contact entry avoids mismatching with stamped contacts.</i></p> 
<p>Kontakteinsätze für gestanzte Kontakte und für gedrehte Kontakte</p> <p>Contact inserts for stamped contacts and for turned contacts</p>	
<p>Voreilender Schutzkontakt</p> <p>First-to-mate last-to-break protective ground contact</p>	
<p>Große Gehäuseauswahl in 2 Bauhöhen (ab Seite 116)</p> <p>Large range of housings in 2 different heights (see page 116)</p>	

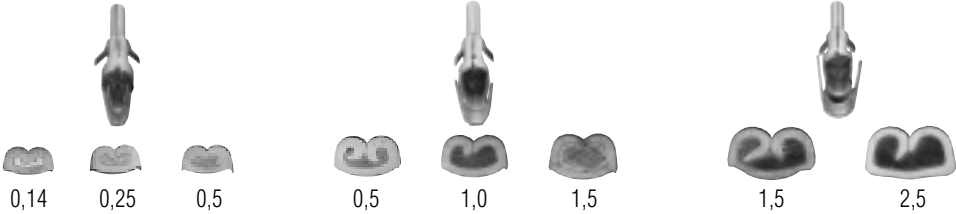
Crimp Technik
Crimp technology

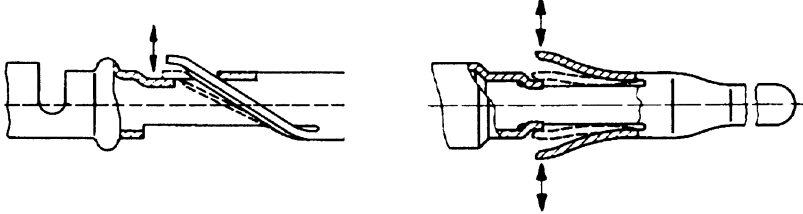
Hauptmerkmale der gestanzten Crimpkontakte
Main characteristics of the stamped crimp contacts

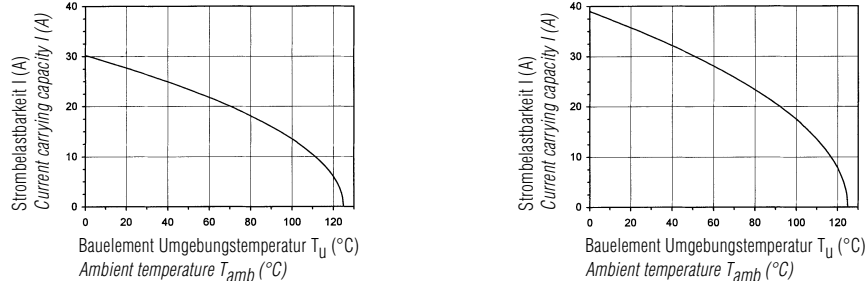
<p>Großer Crimpbereich <i>Large range of wire gauges</i></p> <p>Gasdichte Verbindung (Kaltverschweißung) <i>Gas-tight (coldwelding)</i></p>	<p>.N01 016 0003 (1) ¹⁾ .N01 016 0002 (1) ¹⁾ .N01 016 0005 (1) ¹⁾</p>  <p>0,14 0,25 0,5 0,5 1,0 1,5 1,5 2,5</p>
<p>Gestanzte Crimpkontakte mit Isolierungshalterung um mechanische Beanspruchung von der Crimpverbindung fernzuhalten <i>Stamped crimp contacts with insulation crimp, to absorb mechanical stress from the crimped connection</i></p>	 <p>Isolierungshalterung <i>Insulation grip</i></p>
<p>Mechanischer Rasthakenanschlag bei Buchsen- und Stiftkontakt <i>Mechanical retention spring stop on female and male contact</i></p> <p>Einfache Montage <i>Easy assembly</i></p>	<p>Buchsenkontakt <i>Female contact</i></p> <p>Stiftkontakt <i>Male contact</i></p> 
<p>Kostengünstige, einfache Verarbeitung Werkzeuge siehe Katalog „Werkzeuge“ <i>Economical and easy processing Tools see catalogue „Tools“</i></p>	 <p>Service-Anwendungen <i>Service application</i> Einzel-Fertigung <i>Single production</i> Kleinserie <i>Small series</i> Serie <i>Series</i></p>
<p>Hohe Strombelastbarkeit (siehe Derating Kurven) <i>High current carrying capacity (see derating curves)</i></p>	<p>Beispiel Einzelkontakt / <i>Example single contact</i></p>  <p>Standardkontakt, Anschlussquerschnitt 2,5 mm² <i>Standard contact, wire gauge 2.5 mm²</i></p> <p>Hochstromkontakt, Anschlussquerschnitt 2,5 mm² <i>High current contact, wire gauge 2.5 mm²</i></p>

¹⁾ Erläuterung der Bestell-Nr. für die Kontakte siehe Seite 4
¹⁾ Explanation of the Part No. for contacts see page 4

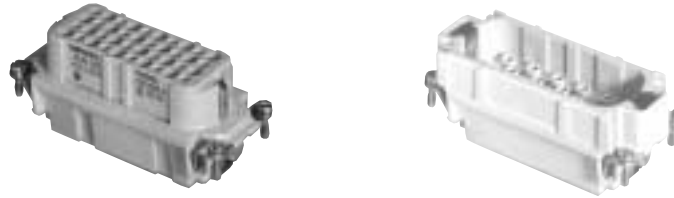
**Kontakteinsätze / Connector inserts**

Allgemeine Kennwerte	General Characteristics	Norm / Standard	Wert / Value							
Polzahl	Number of contacts		7	15	25	40	50 2 x 25	64	128 2 x 64	
Kontaktanordnung	Contact arrangement	DIN EN 175 301-801 (DIN 43652)		•	•	•		•		
Anschlussstechnik	Termination technique		crimpen / crimp, wire wrap							
Max. Leiterdurchmesser	Max. wire diameter		4,1 mm							
Brennbarkeit	Flammbarkeit	UL 94	V-0							
Elektrische Kennwerte	Electrical Characteristics									
Bemessungsspannung ³⁾	Rated voltage	IEC 60664-1	250 V~ (400 V~ ¹⁾) (600 V UL / CSA ⁵⁾)							
Verschmutzungsgrad	Pollution degree	IEC 60664-1	3							
Überspannungskategorie	Installation (overvoltage) category	IEC 60664-1	III							
Isolierstoffgruppe	Material group	IEC 60664-1	III b							
Bemessungs-Stoßspannung	Rated impulse withstand voltage	IEC 60664-1	4 kV							
Spannungsfestigkeit	Voltage proof	IEC 60512-2; Test 4 a	2,2 kV							
Strombelastbarkeit	Rated current	IEC 60512-3; Test 5 b	siehe Derating Kurven / see derating curves							
Bemessungsstrom T _U = 40 °C	Rated current T _{amb} = 40 °C		16 A	12 A	12 A	10 A	10 A	10 A	10 A	
Isolationswiderstand	Insulation resistance	IEC 60512-2; Test 3 a	≥ 10 ¹² Ω ⁴⁾							
Luftstrecke	Clearance	IEC 60664-1	> 3,5 mm							
Kriechstrecke	Creepage	IEC 60664-1	> 4,6 mm							
Klimatische Kennwerte	Climatical Characteristics									
Prüfklasse	Climatic category	IEC 60068-1	40 / 125 / 21							
Obere Grenztemperatur	Upper temperature	IEC 60512-6; Test 11 i	+ 125 °C / 1000 h							
Untere Grenztemperatur	Lower temperature	IEC 60512-6; Test 11 i	- 40 °C / 16 h							
Mechanische Kennwerte	Mechanical Characteristics									
Steck- und Ziehkraft	Insertion and withdrawal forces	IEC 60512-7; Test 13 b	10-15 N	20-30 N	40-60 N	60-90 N	80-120 N	100-150 N	200-300 N	
IP-Schutzart Stifteinsatz	IP-degree of protection pin insert	IEC 60529	ungesteckt/unmated IP00				gesteckt/mated IP20			
IP-Schutzart Buchseneinsatz	IP-degree of protection socket insert	IEC 60529	ungesteckt/unmated IP20				gesteckt/mated IP20			
Gewicht Stifteinsatz	Weight pin insert		8 g	28 g	34 g	53 g	68 g	65 g	130 g	
Gewicht Buchseneinsatz	Weight socket insert		8 g	30 g	38 g	64 g	76 g	82 g	164 g	
Mechanische Lebensdauer	Mechanical operation	IEC 60512-5; Test 9 a	≥ 500 Steckzyklen / mating cycles							
Werkstoffe	Materials									
Kontakteinsatz	Insert		PBTP	PC GV ²⁾						
Farbe	Colour		grau / grey							

¹⁾ bei modifizierter Kontaktanordnung, siehe Seite 24 / modified contact arrangement, see page 24

²⁾ Polycarbonat-glasfaserverstärkt / polycarbonat-glas fibre filled

³⁾ Einschränkung für 8 pol mit Metallgehäuse siehe Seite 10 / Restriction for 8 contacts in metal housing see page 10

⁴⁾ bei Beanspruchung > 10 ¹⁰ Ω / Under operating condition > 10 ¹⁰ Ω

⁵⁾ Hinweisschild für CSA-Anwendung siehe Seite 186 / Label for CSA application see page 186

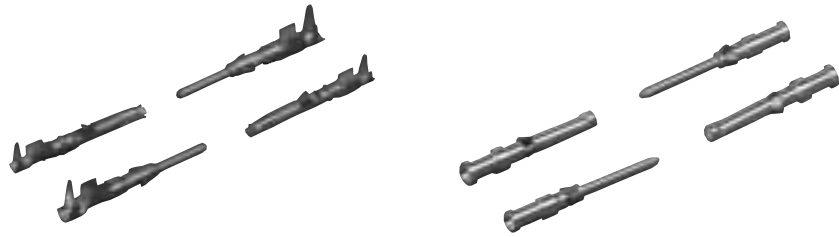
**Gestanzte Crimpkontakte / Stamped crimp contacts**

Elektrische Kennwerte	Electrical Characteristics		
Durchgangswiderstand	Contact resistance	IEC 60512-2; Test 2 a	$\leq 5 \text{ m } \Omega$
Kapazität Kontakt-Kontakt	Capacity contact-contact	IEC 60512-9; Test 22 a	$\geq 2 \text{ p F}$
Kapazität Kontakt-Gehäuse	Capacity contact-housing	IEC 60512-9; Test 22 a	$\geq 3,2 \text{ p F}$
Klimatische Kennwerte	Climatical Characteristics		
Obere Grenztemperatur	Upper temperature	IEC 60512-6; Test 11 i	+ 125 °C
Untere Grenztemperatur	Lower temperature	IEC 60512-6; Test 11 i	- 40 °C
Mechanische Kennwerte	Mechanical Characteristics		
Mechanische Lebensdauer	Mechanical operation	IEC 60512-5; Test 9 a	≥ 500 Steckzyklen / mating cycles
Werkstoffe	Materials		
Stiftkontakt	Male contact		Cu Zn (Messing / brass)
Buchsenkontakt	Female contact		Cu Sn (Zinnbronze / Tin bronze)
Kontaktoberfläche	Contact plating		Ag (silber / silver)

Gedrehte Crimpkontakte / Turned crimp contacts

Elektrische Kennwerte	Electrical Characteristics		
Durchgangswiderstand	Contact resistance	IEC 60512-2	$\leq 5 \text{ m } \Omega$
Klimatische Kennwerte	Climatical Characteristics		
Obere Grenztemperatur	Upper temperature	IEC 60512-6	+ 100 °C
Untere Grenztemperatur	Lower temperature	IEC 60512-6	- 40 °C
Mechanische Kennwerte	Mechanical Characteristics		
Mechanische Lebensdauer	Mechanical operation	IEC 60512-5; Test 9 a	≥ 500 Steckzyklen / mating cycles
Werkstoffe	Materials		
Stiftkontakt	Male contact		Cu Zn (Messing / brass)
Buchsenkontakt	Female contact		Cu Zn (Messing / brass)
Kontaktoberfläche	Contact plating		Ag (silber / silver)

C 146 D
7 + , 8









D

Steckverbinder
Connectors

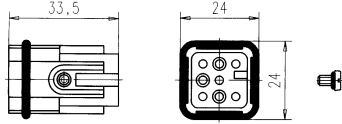
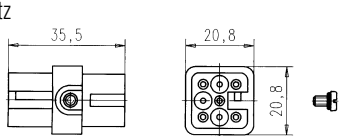
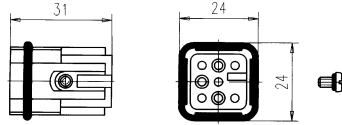
250 V~ in Kunststoffgehäuse
in thermoplastic housings

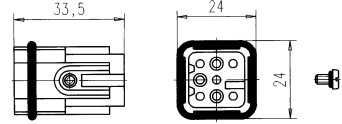
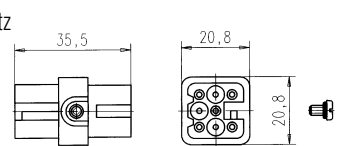
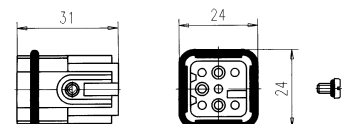
42 V~ in Metallgehäuse
in metal housings

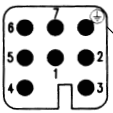
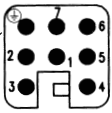
Gehäuse siehe Seite 116-119
Housings see page 116-119

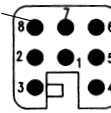
Bezeichnung - Abbildung <i>Description - Figure</i>	Maßzeichnung <i>Drawing</i>	Bestell Nr. / <i>Part No.</i>	
		Stifteinsatz / <i>Male insert</i>	Buchseinsatz / <i>Female insert</i>
Kontakteinsatz / <i>Contact insert</i> 7 +    250 V ~ nur für Kunststoffgehäuse only for thermoplastic housings	Stifteinsatz <i>Male insert</i> 	C146 10A007 000 2 ¹⁾ (für gestanzte Crimpkontakte) <i>(for stamped crimp contacts)</i>	C146 10B007 000 2 ¹⁾ (für gestanzte Crimpkontakte) <i>(for stamped crimp contacts)</i>
	Buchseinsatz <i>Female insert</i> 	Stifteinsatz <i>Male insert</i> 	C146 10A007 500 2 (für gedrehte Crimpkontakte) <i>(for turned crimp contacts)</i>
Kontakteinsatz / <i>Contact insert</i> 8 pol   42 V ~	Stifteinsatz <i>Male insert</i> 	C146 10A008 000 2 (für gestanzte Crimpkontakte) <i>(for stamped crimp contacts)</i>	C146 10B008 000 2 (für gestanzte Crimpkontakte) <i>(for stamped crimp contacts)</i>
	Buchseinsatz <i>Female insert</i> 	Stifteinsatz <i>Male insert</i> 	C146 10A008 500 2 (für gedrehte Crimpkontakte) <i>(for turned crimp contacts)</i>
Kontaktanordnung / <i>Contact arrangement</i> <div style="display: flex; justify-content: space-around;"> <div style="text-align: center;"> <p>7 + </p> <p>Stifteinsatz / <i>Male insert</i></p>  </div> <div style="text-align: center;"> <p>Buchseinsatz / <i>Female insert</i></p>  </div> <div style="text-align: center;"> <p>8 pol</p> <p>Stifteinsatz / <i>Male insert</i></p>  </div> <div style="text-align: center;"> <p>Buchseinsatz / <i>Female insert</i></p>  </div> </div> <p style="text-align: center;">Schutzkontakt voreilend <i>Protective earthing contact preleading</i></p> <p style="text-align: center;">Hinweis: PE-Kontakt, bei Einsatz bis 42 V- als Arbeitskontakt verwendbar. <i>Note: For use up to 42 V-, the PE contact can be used as regular contact.</i></p>			

¹⁾ auch erhältlich als Großpackung, 100 Stück ... 000 2,,C" / *also available for big volume, 100 pcs. ... 000 2,,C"*

C 146 D
7 + \oplus , 8

Crimpkontakte
Crimp contacts

Gestanzte Einzelkontakte
Stamped single contacts



Gedrehte Einzelkontakte
Turned single contacts



Gestanzte Bandkontakte für Crimpzangen
Stamped contacts on reel for hand crimping tools



200 / 100 Stück
200 / 100 pcs

Gestanzte Bandkontakte für Crimpmaschinen
Stamped contacts on reel for crimp machines



2000 Stück
(Zuführung links
oder rechts)
2000 pcs
(feeding left or
right hand side)

Lieferform <i>Supplied as</i>	für Leiter- querschnitt <i>for wire gauge</i>	AWG	Stück- zahl <i>Pieces</i>	Bestell Nr. ¹⁾ Stiftkontakt <i>Male contact</i>	Part No. ¹⁾ Buchsenkontakt <i>Female contact</i>	Bestell Nr. ¹⁾ Stiftkontakt <i>Male contact</i>	Part No. ¹⁾ Buchsenkontakt <i>Female contact</i>
Gestanzte Einzelkontakte / <i>Stamped single contacts</i>				versilbert / <i>silver plating</i>		vergoldet / <i>gold plating</i>	
Standard Hochstrom <i>High current</i>	0,14 - 0,5 mm ²	26 - 20	100	VN01 016 0003 (1)	VN02 016 0003 (1)	VN01 016 0003 (2)	VN02 016 0003 (2)
	0,5 - 1,5 mm ²	20 - 16	100	VN01 016 0002 (1)	VN02 016 0002 (1)	VN01 016 0002 (2)	VN02 016 0002 (2)
	1,5 - 2,5 mm ²	16 - 14	100	VN01 016 0005 (1)	VN02 016 0005 (1)	VN01 016 0005 (2)	VN02 016 0005 (2)
	0,5 - 1,5 mm ²	20 - 16	100	VN01 016 0015 (1)	VN02 016 0015 (1)		
	1,5 - 2,5 mm ²	16 - 14	100	VN01 016 0016 (1)	VN02 016 0016 (1)		
Gestanzte Bandkontakte für Crimpzangen / <i>Stamped Contacts on reel for hand crimp tools</i>							
Standard Hochstrom <i>High current</i>	0,14 - 0,5 mm ²	26 - 20	200	ZN01 016 0003 (1)	ZN02 016 0003 (1)	ZN01 016 0003 (2)	ZN02 016 0003 (2)
	0,5 - 1,5 mm ²	20 - 16	200	ZN01 016 0002 (1)	ZN02 016 0002 (1)	ZN01 016 0002 (2)	ZN02 016 0002 (2)
	1,5 - 2,5 mm ²	16 - 14	100	ZN01 016 0005 (1)	ZN02 016 0005 (1)	ZN01 016 0005 (2)	ZN02 016 0005 (2)
	0,5 - 1,5 mm ²	20 - 16	200	ZN01 016 0015 (1)	ZN02 016 0015 (1)		
	1,5 - 2,5 mm ²	16 - 14	100	ZN01 016 0016 (1)	ZN02 016 0016 (1)		
Gestanzte Bandkontakte für Crimpmaschinen / <i>Stamped contacts on reel for crimp machines</i>							
Kontaktzuführung rechts <i>Contact feeding right hand side</i>	0,14 - 0,5 mm ²	26 - 20	2000	HN01 016 0003 (1)	HN02 016 0003 (1)	HN01 016 0003 (2)	HN02 016 0003 (2)
	0,5 - 1,5 mm ²	20 - 16	2000	HN01 016 0002 (1)	HN02 016 0002 (1)	HN01 016 0002 (2)	HN02 016 0002 (2)
	Standard 1,5 - 2,5 mm ²	16 - 14	2000	HN01 016 0005 (1)	HN02 016 0005 (1)	HN01 016 0005 (2)	HN02 016 0005 (2)
	Hochstrom 1,5 - 2,5 mm ²	16 - 14	2000	HN01 016 0015 (1)	HN02 016 0015 (1)		
	1,5 - 2,5 mm ²	16 - 14	2000	HN01 016 0016 (1)	HN02 016 0016 (1)		
Kontaktzuführung links <i>Contact feeding left hand side</i>	0,14 - 0,5 mm ²	26 - 20	2000	TN01 016 0003 (1)	TN02 016 0003 (1)	TN01 016 0003 (2)	TN02 016 0003 (2)
	0,5 - 1,5 mm ²	20 - 16	2000	TN01 016 0002 (1)	TN02 016 0002 (1)	TN01 016 0002 (2)	TN02 016 0002 (2)
	Standard 1,5 - 2,5 mm ²	16 - 14	2000	TN01 016 0005 (1)	TN02 016 0005 (1)	TN01 016 0005 (2)	TN02 016 0005 (2)
	Hochstrom 1,5 - 2,5 mm ²	16 - 14	2000	TN01 016 0015 (1)	TN02 016 0015 (1)		
	1,5 - 2,5 mm ²	18 - 14	2000	TN01 016 0016 (1)	TN02 016 0016 (1)		
Gedrehte Crimpkontakte / <i>Turned crimp contacts</i>							
Einzelkontakt <i>Single contact</i>	0,14 - 0,37 mm ²	26 - 22	100	VN01 016 0024 (1)C	VN02 016 0024 (1)C	VN01 016 0024 (2)C	VN02 016 0024 (2)C
	0,5 mm ²	20	100	VN01 016 0025 (1)C	VN02 016 0025 (1)C	VN01 016 0025 (2)C	VN02 016 0025 (2)C
	0,75 - 1,0 mm ²	20 - 16	100	VN01 016 0026 (1)C	VN02 016 0026 (1)C	VN01 016 0026 (2)C	VN02 016 0026 (2)C
	1,5 mm ²	16 - 15	100	VN01 016 0027 (1)C	VN02 016 0027 (1)C	VN01 016 0027 (2)C	VN02 016 0027 (2)C
	2,5 mm ²	14	100	VN01 016 0028 (1)C	VN02 016 0028 (1)C	VN01 016 0028 (2)C	VN02 016 0028 (2)C

Derating Kurven / *Derating curves*

Gestanzte Kontakte
Stamped contacts

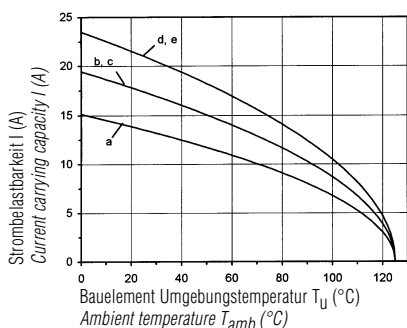

Gedrehte Kontakte
Turned contacts

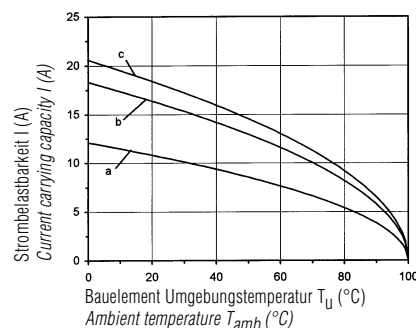

Kurve / <i>Curve</i>	Kontakt / <i>Contact</i>	Querschnitt / <i>Wire gauge</i>	Kurve / <i>Curve</i>	Kontakt / <i>Contact</i>	Querschnitt / <i>Wire gauge</i>
a	Standard gestanzte	0,5 mm ²	a	Standard gedrehte	0,5 mm ²
b	Standard gestanzte	1,5 mm ²	b	Standard gedrehte	1,5 mm ²
c		2,5 mm ²	c		2,5 mm ²
d	Hochstrom gestanzte	1,5 mm ²			
e	Hochstrom gestanzte	2,5 mm ²			

¹⁾ Erläuterung der Bestell-Nr. für die Kontakte siehe Seite 4
¹⁾ Explanation of the Part No. for contacts see page 4

Abisolierlängen siehe S. 208
Stripping length see p. 208

C 146 D
15 + 

250 V~ 10 A/15 A DIN EN 175 301-801 (DIN 43652)

Steckverbinder
Connectors

Gehäuse siehe Seite 120–123
Housings see page 120–123

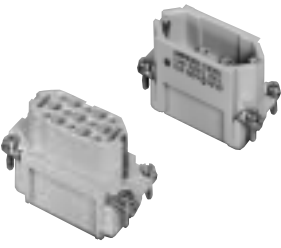
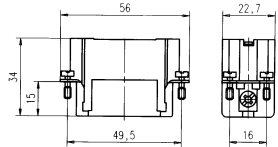
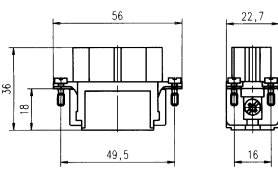
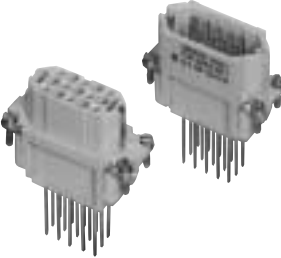
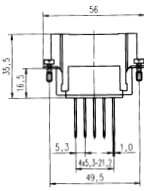
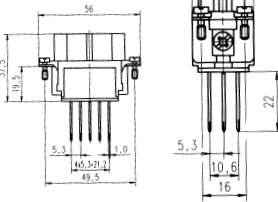
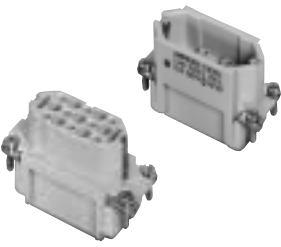
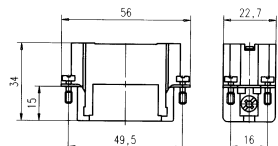
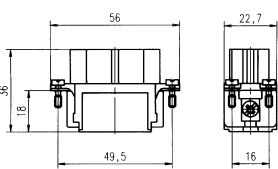
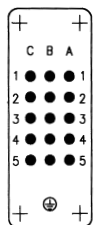
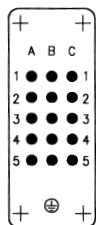
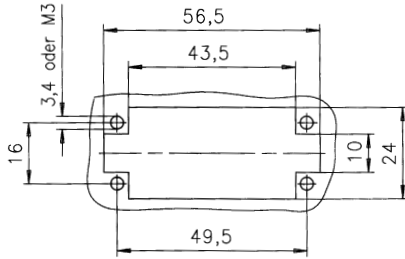
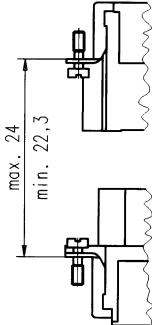
Bezeichnung - Abbildung Description - Figure	Maßzeichnung Drawing	Bestell Nr. / Part No.	
		Stifteinsatz / Male insert	Buchseinsatz / Female insert
Kontakteinsatz Contact insert 	Stifteinsatz Male insert  Buchseinsatz Female insert 	C146 10A015 000 2 (für gestanzte Crimpkontakte) (for stamped crimp contacts) C146 10A015 500 2 (für gedrehte Crimpkontakte) (for turned crimp contacts)	C146 10B015 000 2 (für gestanzte Crimpkontakte) (for stamped crimp contacts) C146 10B015 500 2 (für gedrehte Crimpkontakte) (for turned crimp contacts)
Wickelanschluss ²⁾ Wire wrap termination 	Stifteinsatz Male insert  Buchseinsatz Female insert 	C146 10A015 009 2	C146 10B015 009 2
Kontakteinsatz 2 X PE Anschluss ¹⁾ Contact insert 2 X PE termination ¹⁾ 	Stifteinsatz Male insert  Buchseinsatz Female insert 	C146 10A015 060 2 (für gestanzte Crimpkontakte) (for stamped crimp contacts)	C146 10B015 060 2 (für gestanzte Crimpkontakte) (for stamped crimp contacts)
Montageanleitung, Ansicht von Steckverbinder-Anschlussseite Assembly instructions, view from termination side			
Stifteinsatz Male insert 	Buchseinsatz Female insert 	Montageausschnitt (Kontaktträger) Panel cut out (insert) 	

¹⁾ Beim Einbau der Steckverbinder in nicht leitende Gehäuse sind beide Schutzleiter (Ausführung 2 x PE) anzuschließen.
If connectors are mounted in non conductive housings both protective earthing terminals shall be mounted.

²⁾ IP-Schutzart im Anschlussbereich IP 00
IP-degree of protection on termination side IP 00

C 146 D

15 + 

Crimpkontakte
Crimp contacts

Gestanzte Einzelkontakte
Stamped single contacts



Gedrehte Einzelkontakte
Turned single contacts



Gestanzte Bandkontakte für Crimpzangen
Stamped contacts on reel for hand crimping tools



200 / 100 Stück

200 / 100 pcs

Gestanzte Bandkontakte für Crimpmaschinen
Stamped contacts on reel for crimp machines



2000 Stück
(Zuführung links oder rechts)

2000 pcs
(feeding left or right hand side)

D

Lieferform <i>Supplied as</i>	für Leiter- querschnitt <i>for wire gauge</i>	AWG	Stück- zahl <i>Pieces</i>	Bestell Nr. ¹⁾ Stiftkontakt <i>Male contact</i>	Part No. ¹⁾ Buchsenkontakt <i>Female contact</i>	Bestell Nr. ¹⁾ Stiftkontakt <i>Male contact</i>	Part No. ¹⁾ Buchsenkontakt <i>Female contact</i>
Gestanzte Einzelkontakte / <i>Stamped single contacts</i>				versilbert / <i>silver plating</i>		vergoldet / <i>gold plating</i>	
Standard Hochstrom <i>High current</i>	0,14 - 0,5 mm ²	26 - 20	100	VN01 016 0003 (1)	VN02 016 0003 (1)	VN01 016 0003 (2)	VN02 016 0003 (2)
	0,5 - 1,5 mm ²	20 - 16	100	VN01 016 0002 (1)	VN02 016 0002 (1)	VN01 016 0002 (2)	VN02 016 0002 (2)
	1,5 - 2,5 mm ²	16 - 14	100	VN01 016 0005 (1)	VN02 016 0005 (1)	VN01 016 0005 (2)	VN02 016 0005 (2)
	0,5 - 1,5 mm ²	20 - 16	100	VN01 016 0015 (1)	VN02 016 0015 (1)		
	1,5 - 2,5 mm ²	16 - 14	100	VN01 016 0016 (1)	VN02 016 0016 (1)		
Gestanzte Bandkontakte für Crimpzangen / <i>Stamped Contacts on reel for hand crimp tools</i>							
Standard Hochstrom <i>High current</i>	0,14 - 0,5 mm ²	26 - 20	200	ZN01 016 0003 (1)	ZN02 016 0003 (1)	ZN01 016 0003 (2)	ZN02 016 0003 (2)
	0,5 - 1,5 mm ²	20 - 16	200	ZN01 016 0002 (1)	ZN02 016 0002 (1)	ZN01 016 0002 (2)	ZN02 016 0002 (2)
	1,5 - 2,5 mm ²	16 - 14	100	ZN01 016 0005 (1)	ZN02 016 0005 (1)	ZN01 016 0005 (2)	ZN02 016 0005 (2)
	0,5 - 1,5 mm ²	20 - 16	200	ZN01 016 0015 (1)	ZN02 016 0015 (1)		
	1,5 - 2,5 mm ²	16 - 14	100	ZN01 016 0016 (1)	ZN02 016 0016 (1)		
Gestanzte Bandkontakte für Crimpmaschinen / <i>Stamped contacts on reel for crimp machines</i>							
Kontaktzuführung rechts <i>Contact feeding right hand side</i>	0,14 - 0,5 mm ²	26 - 20	2000	HN01 016 0003 (1)	HN02 016 0003 (1)	HN01 016 0003 (2)	HN02 016 0003 (2)
	0,5 - 1,5 mm ²	20 - 16	2000	HN01 016 0002 (1)	HN02 016 0002 (1)	HN01 016 0002 (2)	HN02 016 0002 (2)
	1,5 - 2,5 mm ²	16 - 14	2000	HN01 016 0005 (1)	HN02 016 0005 (1)	HN01 016 0005 (2)	HN02 016 0005 (2)
	0,5 - 1,5 mm ²	20 - 16	2000	HN01 016 0015 (1)	HN02 016 0015 (1)		
	1,5 - 2,5 mm ²	16 - 14	2000	HN01 016 0016 (1)	HN02 016 0016 (1)		
Kontaktzuführung links <i>Contact feeding left hand side</i>	0,14 - 0,5 mm ²	26 - 20	2000	TN01 016 0003 (1)	TN02 016 0003 (1)	TN01 016 0003 (2)	TN02 016 0003 (2)
	0,5 - 1,5 mm ²	20 - 16	2000	TN01 016 0002 (1)	TN02 016 0002 (1)	TN01 016 0002 (2)	TN02 016 0002 (2)
	1,5 - 2,5 mm ²	16 - 14	2000	TN01 016 0005 (1)	TN02 016 0005 (1)	TN01 016 0005 (2)	TN02 016 0005 (2)
	0,5 - 1,5 mm ²	20 - 16	2000	TN01 016 0015 (1)	TN02 016 0015 (1)		
	1,5 - 2,5 mm ²	18 - 14	2000	TN01 016 0016 (1)	TN02 016 0016 (1)		
Gedrehte Crimpkontakte / <i>Turned crimp contacts</i>							
Einzelkontakt <i>Single contact</i>	0,14 - 0,37 mm ²	26 - 22	100	VN01 016 0024 (1)C	VN02 016 0024 (1)C	VN01 016 0024 (2)C	VN02 016 0024 (2)C
	0,5 mm ²	20	100	VN01 016 0025 (1)C	VN02 016 0025 (1)C	VN01 016 0025 (2)C	VN02 016 0025 (2)C
	0,75 - 1,0 mm ²	20 - 16	100	VN01 016 0026 (1)C	VN02 016 0026 (1)C	VN01 016 0026 (2)C	VN02 016 0026 (2)C
	1,5 mm ²	16 - 15	100	VN01 016 0027 (1)C	VN02 016 0027 (1)C	VN01 016 0027 (2)C	VN02 016 0027 (2)C
	2,5 mm ²	14	100	VN01 016 0028 (1)C	VN02 016 0028 (1)C	VN01 016 0028 (2)C	VN02 016 0028 (2)C

Gestanzte Kontakte
Stamped contacts

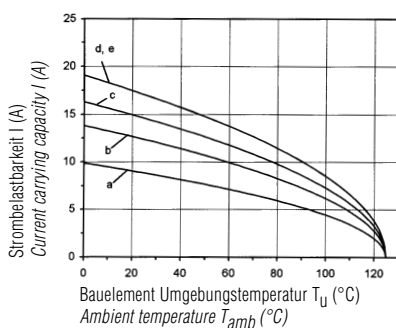

Gedrehte Kontakte
Turned contacts

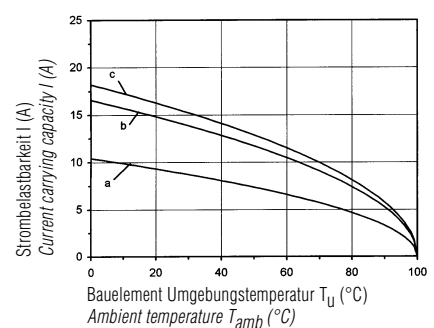

Kurve / <i>Curve</i>	Kontakt / <i>Contact</i>	Querschnitt / <i>Wire gauge</i>	Kurve / <i>Curve</i>	Kontakt / <i>Contact</i>	Querschnitt / <i>Wire gauge</i>
a	Standard gestanzte	0,5 mm ²	a	Standard gedrehte	0,5 mm ²
b	Standard gestanzte	1,5 mm ²	b	Standard gedrehte	1,5 mm ²
c		2,5 mm ²	c		2,5 mm ²
d	Hochstrom gestanzte	1,5 mm ²			
e	High current, stamped	2,5 mm ²			

¹⁾ Erläuterung der Bestell-Nr. für die Kontakte siehe Seite 4

¹⁾ Explanation of the Part No. for contacts see page 4

Abisolierlängen siehe S. 208



Stripping length see p. 208

C 146 D
25 + 

250 V~ 10 A/15 A DIN EN 175 301-801 (DIN 43 652)

Steckverbinder
Connectors

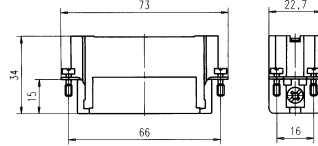
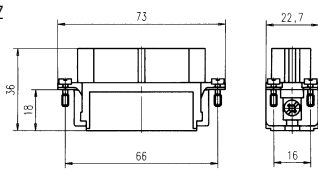
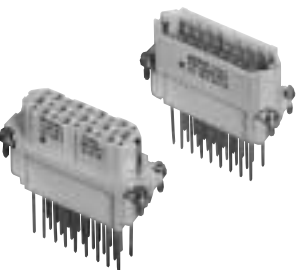
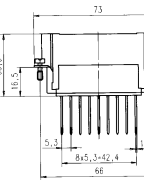
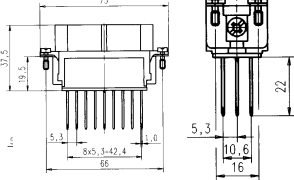
Gehäuse siehe Seite 124-127
Housings see page 124-127

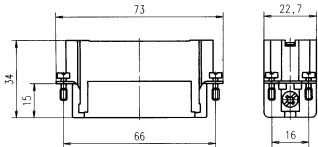
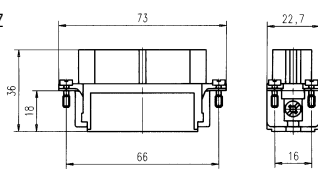
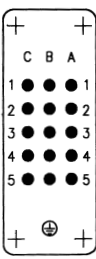
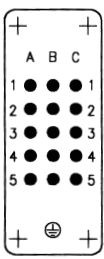
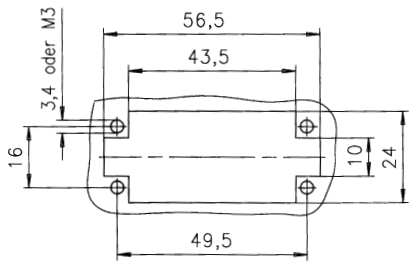
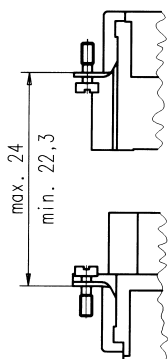
Bezeichnung - Abbildung Description - Figure	Maßzeichnung Drawing	Bestell Nr. / Part No.	
		Stifteinsatz / Male insert	Buchseinsatz / Female insert
Kontakteinsatz Contact insert 	Stifteinsatz Male insert  Buchseinsatz Female insert 	C146 10A025 000 2 (für gestanzte Crimpkontakte) (for stamped crimp contacts) C146 10A025 500 2 (für gedrehte Crimpkontakte) (for turned crimp contacts)	C146 10B025 000 2 (für gestanzte Crimpkontakte) (for stamped crimp contacts) C146 10B025 500 2 (für gedrehte Crimpkontakte) (for turned crimp contacts)
Wickelanschluss ²⁾ Wire wrap termination 	Stifteinsatz Male insert  Buchseinsatz Female insert 	C146 10A025 009 2	C146 10B025 009 2
Kontakteinsatz 2 X PE Anschluss ¹⁾ Contact insert 2 X PE termination ¹⁾ 	Stifteinsatz Male insert  Buchseinsatz Female insert 	C146 10A025 060 2 (für gestanzte Crimpkontakte) (for stamped crimp contacts)	C146 10B025 060 2 (für gestanzte Crimpkontakte) (for stamped crimp contacts)
Montageanleitung, Ansicht von Steckverbinder-Anschlussseite Assembly instructions, view from termination side			
Stifteinsatz Male insert 	Buchseinsatz Female insert 	Montageausschnitt (Kontaktträger) Panel cut out (insert) 	

¹⁾ Beim Einbau der Steckverbinder in nicht leitende Gehäuse sind beide Schutzleiter (Ausführung 2 x PE) anzuschließen.
If connectors are mounted in non conductive housings both protective earthing terminals shall be mounted.

²⁾ IP-Schutzart im Anschlussbereich IP 00
IP-degree of protection on termination side IP 00

C 146 D 25 +

Gestanzte Einzelkontakte
Stamped single contacts



Gedrehte Einzelkontakte
Turned single contacts



Gestanzte Bandkontakte für Crimpzangen
Stamped contacts on reel for hand crimping tools



200 / 100 Stück

200 / 100 pcs

Gestanzte Bandkontakte für Crimpmaschinen
Stamped contacts on reel for crimp machines

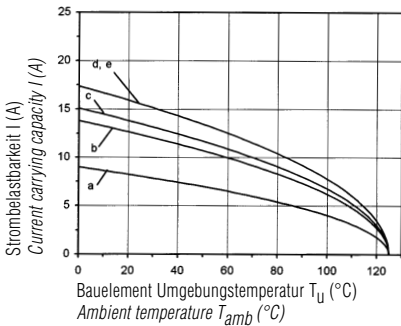
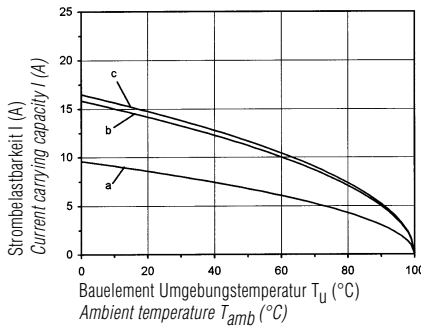

Crimpkontakte Crimp contacts

Lieferform Supplied as	für Leiter- querschnitt for wire gauge	AWG	Stück- zahl Pieces	Bestell Nr. ¹⁾ Stiftkontakt Male contact	Part No. ¹⁾ Buchsenkontakt Female contact	Bestell Nr. ¹⁾ Stiftkontakt Male contact	Part No. ¹⁾ Buchsenkontakt Female contact
Gestanzte Einzelkontakte / Stamped single contacts				versilbert / silver plating		vergoldet / gold plating	
Standard Hochstrom High current	0,14 - 0,5 mm ²	26 - 20	100	VN01 016 0003 (1)	VN02 016 0003 (1)	VN01 016 0003 (2)	VN02 016 0003 (2)
	0,5 - 1,5 mm ²	20 - 16	100	VN01 016 0002 (1)	VN02 016 0002 (1)	VN01 016 0002 (2)	VN02 016 0002 (2)
	1,5 - 2,5 mm ²	16 - 14	100	VN01 016 0005 (1)	VN02 016 0005 (1)	VN01 016 0005 (2)	VN02 016 0005 (2)
	0,5 - 1,5 mm ²	20 - 16	100	VN01 016 0015 (1)	VN02 016 0015 (1)		
	1,5 - 2,5 mm ²	16 - 14	100	VN01 016 0016 (1)	VN02 016 0016 (1)		
Gestanzte Bandkontakte für Crimpzangen / Stamped Contacts on reel for hand crimp tools							
Standard Hochstrom High current	0,14 - 0,5 mm ²	26 - 20	200	ZN01 016 0003 (1)	ZN02 016 0003 (1)	ZN01 016 0003 (2)	ZN02 016 0003 (2)
	0,5 - 1,5 mm ²	20 - 16	200	ZN01 016 0002 (1)	ZN02 016 0002 (1)	ZN01 016 0002 (2)	ZN02 016 0002 (2)
	1,5 - 2,5 mm ²	16 - 14	100	ZN01 016 0005 (1)	ZN02 016 0005 (1)	ZN01 016 0005 (2)	ZN02 016 0005 (2)
	0,5 - 1,5 mm ²	20 - 16	200	ZN01 016 0015 (1)	ZN02 016 0015 (1)		
	1,5 - 2,5 mm ²	16 - 14	100	ZN01 016 0016 (1)	ZN02 016 0016 (1)		
Gestanzte Bandkontakte für Crimpmaschinen / Stamped contacts on reel for crimp machines							
Kontaktzuführung rechts Contact feeding right hand side Standard Hochstrom High current	0,14 - 0,5 mm ²	26 - 20	2000	HN01 016 0003 (1)	HN02 016 0003 (1)	HN01 016 0003 (2)	HN02 016 0003 (2)
	0,5 - 1,5 mm ²	20 - 16	2000	HN01 016 0002 (1)	HN02 016 0002 (1)	HN01 016 0002 (2)	HN02 016 0002 (2)
	1,5 - 2,5 mm ²	16 - 14	2000	HN01 016 0005 (1)	HN02 016 0005 (1)	HN01 016 0005 (2)	HN02 016 0005 (2)
	0,5 - 1,5 mm ²	20 - 16	2000	HN01 016 0015 (1)	HN02 016 0015 (1)		
	1,5 - 2,5 mm ²	16 - 14	2000	HN01 016 0016 (1)	HN02 016 0016 (1)		
Kontaktzuführung links Contact feeding left hand side Standard Hochstrom High current	0,14 - 0,5 mm ²	26 - 20	2000	TN01 016 0003 (1)	TN02 016 0003 (1)	TN01 016 0003 (2)	TN02 016 0003 (2)
	0,5 - 1,5 mm ²	20 - 16	2000	TN01 016 0002 (1)	TN02 016 0002 (1)	TN01 016 0002 (2)	TN02 016 0002 (2)
	1,5 - 2,5 mm ²	16 - 14	2000	TN01 016 0005 (1)	TN02 016 0005 (1)	TN01 016 0005 (2)	TN02 016 0005 (2)
	0,5 - 1,5 mm ²	20 - 16	2000	TN01 016 0015 (1)	TN02 016 0015 (1)		
	1,5 - 2,5 mm ²	18 - 14	2000	TN01 016 0016 (1)	TN02 016 0016 (1)		
Gedrehte Crimpkontakte / Turned crimp contacts							
Einzelkontakt Single contact	0,14 - 0,37 mm ²	26 - 22	100	VN01 016 0024 (1)C	VN02 016 0024 (1)C	VN01 016 0024 (2)C	VN02 016 0024 (2)C
	0,5 mm ²	20	100	VN01 016 0025 (1)C	VN02 016 0025 (1)C	VN01 016 0025 (2)C	VN02 016 0025 (2)C
	0,75 - 1,0 mm ²	20 - 16	100	VN01 016 0026 (1)C	VN02 016 0026 (1)C	VN01 016 0026 (2)C	VN02 016 0026 (2)C
	1,5 mm ²	16 - 15	100	VN01 016 0027 (1)C	VN02 016 0027 (1)C	VN01 016 0027 (2)C	VN02 016 0027 (2)C
	2,5 mm ²	14	100	VN01 016 0028 (1)C	VN02 016 0028 (1)C	VN01 016 0028 (2)C	VN02 016 0028 (2)C
Gestanzte Kontakte Stamped contacts				Gedrehte Kontakte Turned contacts			
							
Kurve / Curve	Kontakt / Contact	Querschnitt / Wire gauge		Kurve / Curve	Kontakt / Contact	Querschnitt / Wire gauge	
a	Standard gestanzte	0,5 mm ²		a	Standard gedrehte	0,5 mm ²	
b	Standard gestanzte	1,5 mm ²		b	Standard gedrehte	1,5 mm ²	
c		2,5 mm ²		c		2,5 mm ²	
d	Hochstrom gestanzte	1,5 mm ²					
e	Hochstrom gestanzte	2,5 mm ²					

¹⁾ Erläuterung der Bestell-Nr. für die Kontakte siehe Seite 4

¹⁾ Explanation of the Part No. for contacts see page 4

Abisolierlängen siehe S. 208

Stripping length see p. 208

C 146 D

40 + 

250 V~ 10 A/15 A DIN EN 175 301-801 (DIN 43 652)

D

Steckverbinder
Connectors

Gehäuse siehe Seite 144–151
Housings see page 144–151

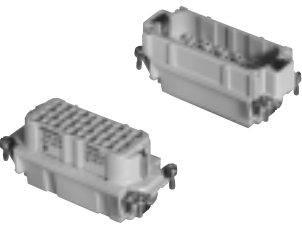
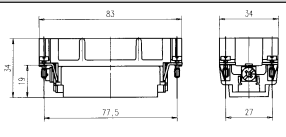
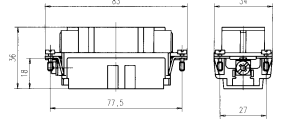
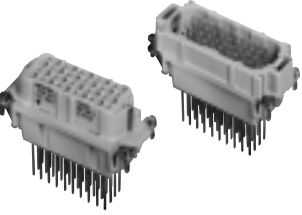
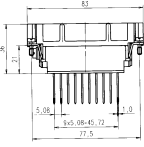
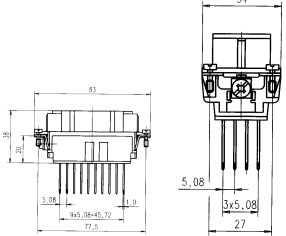
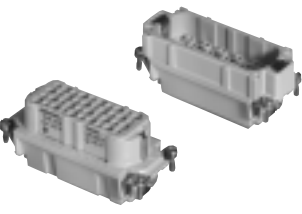
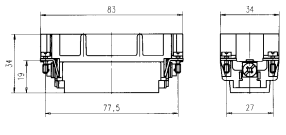
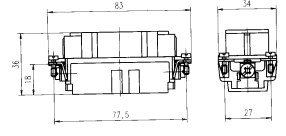
Bezeichnung - Abbildung Description - Figure	Maßzeichnung Drawing	Bestell Nr. / Part No.	
		Stifteinsatz / Male insert	Buchseinsatz / Female insert
Kontakteinsatz Contact insert 	Stifteinsatz Male insert 	C146 10A040 000 2 (für gestanzte Crimpkontakte) (for stamped crimp contacts)	C146 10B040 000 2 (für gestanzte Crimpkontakte) (for stamped crimp contacts)
	Buchseinsatz Female insert 	C146 10A040 500 2 (für gedrehte Crimpkontakte) (for turned crimp contacts)	C146 10B040 500 2 (für gedrehte Crimpkontakte) (for turned crimp contacts)
Wickelanschluss ³⁾ Wire wrap termination 	Stifteinsatz Male insert 	Buchseinsatz Female insert 	C146 10A040 009 2 C146 10B040 009 2
Kontakteinsatz 2 X PE Anschluss ¹⁾ Contact insert 2 X PE termination ¹⁾ 	Stifteinsatz Male insert 	C146 10A040 060 2 (für gestanzte Crimpkontakte) (for stamped crimp contacts)	C146 10B040 060 2 (für gestanzte Crimpkontakte) (for stamped crimp contacts)
	Buchseinsatz Female insert 		

Montageanleitung, Ansicht von Steckverbinder-Anschlussseite / Assembly instructions, view from termination side

Stifteinsatz
Male insert

Buchseinsatz
Female insert

Montageausschnitt (Kontaktträger)
Panel cut out (insert)

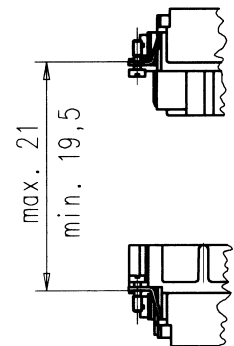
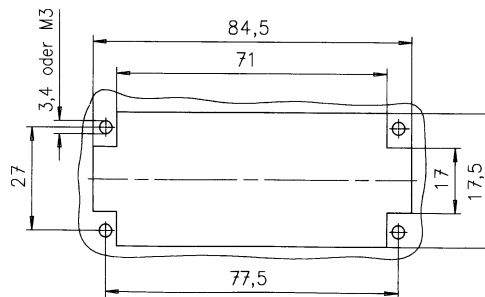
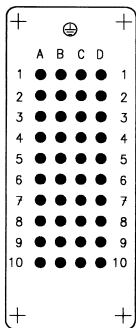
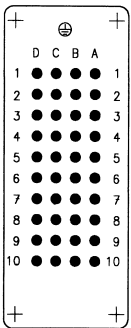

¹⁾ Beim Einbau der Steckverbinder in nicht leitende Gehäuse sind beide Schutzleiter (Ausführung 2 x PE) anzuschließen.
If connectors are mounted in non conductive housings both protective earthing terminals shall be mounted.

²⁾ Für Gehäuse mit niedriger Bauform / for low profile housings

³⁾ IP-Schutzart im Anschlussbereich IP 00
IP-degree of protection on termination side IP 00

C 146 D

40 + 

Crimpkontakte
Crimp contacts

Gestanzte Einzelkontakte
Stamped single contacts



Gedrehte Einzelkontakte
Turned single contacts



Gestanzte Bandkontakte für Crimpzangen
Stamped contacts on reel for hand crimping tools



200 / 100 Stück

200 / 100 pcs

Gestanzte Bandkontakte für Crimpmaschinen
Stamped contacts on reel for crimp machines



2000 Stück
(Zuführung links
oder rechts)

2000 pcs
(feeding left or
right hand side)

D

Lieferform Supplied as	für Leiter- querschnitt for wire gauge	AWG	Stück- zahl Pieces	Bestell Nr. ¹⁾ Stiftkontakt Male contact	Part No. ¹⁾ Buchsenkontakt Female contact	Bestell Nr. ¹⁾ Stiftkontakt Male contact	Part No. ¹⁾ Buchsenkontakt Female contact	
Gestanzte Einzelkontakte / Stamped single contacts				versilbert / silver plating		vergoldet / gold plating		
Standard	0,14 - 0,5 mm ²	26 - 20	100	VN01 016 0003 (1)	VN02 016 0003 (1)	VN01 016 0003 (2)	VN02 016 0003 (2)	
	0,5 - 1,5 mm ²	20 - 16	100	VN01 016 0002 (1)	VN02 016 0002 (1)	VN01 016 0002 (2)	VN02 016 0002 (2)	
	1,5 - 2,5 mm ²	16 - 14	100	VN01 016 0005 (1)	VN02 016 0005 (1)	VN01 016 0005 (2)	VN02 016 0005 (2)	
	Hochstrom High current	0,5 - 1,5 mm ²	20 - 16	VN01 016 0015 (1)	VN02 016 0015 (1)			
	1,5 - 2,5 mm ²	16 - 14	100	VN01 016 0016 (1)	VN02 016 0016 (1)			
Gestanzte Bandkontakte für Crimpzangen / Stamped Contacts on reel for hand crimp tools								
Standard	0,14 - 0,5 mm ²	26 - 20	200	ZN01 016 0003 (1)	ZN02 016 0003 (1)	ZN01 016 0003 (2)	ZN02 016 0003 (2)	
	0,5 - 1,5 mm ²	20 - 16	200	ZN01 016 0002 (1)	ZN02 016 0002 (1)	ZN01 016 0002 (2)	ZN02 016 0002 (2)	
	1,5 - 2,5 mm ²	16 - 14	100	ZN01 016 0005 (1)	ZN02 016 0005 (1)	ZN01 016 0005 (2)	ZN02 016 0005 (2)	
	Hochstrom High current	0,5 - 1,5 mm ²	20 - 16	ZN01 016 0015 (1)	ZN02 016 0015 (1)			
	1,5 - 2,5 mm ²	16 - 14	100	ZN01 016 0016 (1)	ZN02 016 0016 (1)			
Gestanzte Bandkontakte für Crimpmaschinen / Stamped contacts on reel for crimp machines								
Kontaktzuführung rechts Contact feeding right hand side	0,14 - 0,5 mm ²	26 - 20	2000	HN01 016 0003 (1)	HN02 016 0003 (1)	HN01 016 0003 (2)	HN02 016 0003 (2)	
	0,5 - 1,5 mm ²	20 - 16	2000	HN01 016 0002 (1)	HN02 016 0002 (1)	HN01 016 0002 (2)	HN02 016 0002 (2)	
	Standard	1,5 - 2,5 mm ²	16 - 14	2000	HN01 016 0005 (1)	HN02 016 0005 (1)	HN01 016 0005 (2)	HN02 016 0005 (2)
	Hochstrom High current	0,5 - 1,5 mm ²	20 - 16	2000	HN01 016 0015 (1)	HN02 016 0015 (1)		
	1,5 - 2,5 mm ²	16 - 14	2000	HN01 016 0016 (1)	HN02 016 0016 (1)			
Kontaktzuführung links Contact feeding left hand side	0,14 - 0,5 mm ²	26 - 20	2000	TN01 016 0003 (1)	TN02 016 0003 (1)	TN01 016 0003 (2)	TN02 016 0003 (2)	
	0,5 - 1,5 mm ²	20 - 16	2000	TN01 016 0002 (1)	TN02 016 0002 (1)	TN01 016 0002 (2)	TN02 016 0002 (2)	
	Standard	1,5 - 2,5 mm ²	16 - 14	2000	TN01 016 0005 (1)	TN02 016 0005 (1)	TN01 016 0005 (2)	TN02 016 0005 (2)
	Hochstrom High current	0,5 - 1,5 mm ²	20 - 16	2000	TN01 016 0015 (1)	TN02 016 0015 (1)		
	1,5 - 2,5 mm ²	18 - 14	2000	TN01 016 0016 (1)	TN02 016 0016 (1)			
Gedrehte Crimpkontakte / Turned crimp contacts								
Einzelkontakt Single contact	0,14 - 0,37 mm ²	26 - 22	100	VN01 016 0024 (1)C	VN02 016 0024 (1)C	VN01 016 0024 (2)C	VN02 016 0024 (2)C	
	0,5 mm ²	20	100	VN01 016 0025 (1)C	VN02 016 0025 (1)C	VN01 016 0025 (2)C	VN02 016 0025 (2)C	
	0,75 - 1,0 mm ²	20 - 16	100	VN01 016 0026 (1)C	VN02 016 0026 (1)C	VN01 016 0026 (2)C	VN02 016 0026 (2)C	
	1,5 mm ²	16 - 15	100	VN01 016 0027 (1)C	VN02 016 0027 (1)C	VN01 016 0027 (2)C	VN02 016 0027 (2)C	
	2,5 mm ²	14	100	VN01 016 0028 (1)C	VN02 016 0028 (1)C	VN01 016 0028 (2)C	VN02 016 0028 (2)C	

Gestanzte Kontakte
Stamped contacts

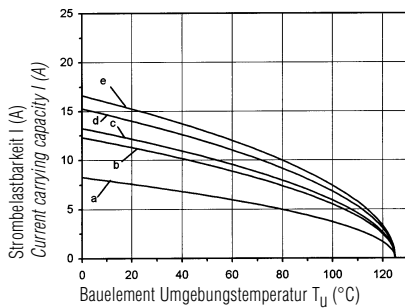

Gedrehte Kontakte
Turned contacts

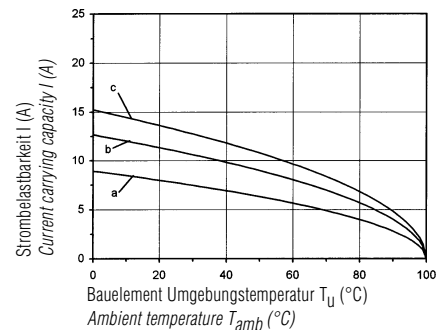

Kurve / Curve	Kontakt / Contact	Querschnitt / Wire gauge	Kurve / Curve	Kontakt / Contact	Querschnitt / Wire gauge
a	Standard gestanzte	0,5 mm ²	a	Standard gedrehte	0,5 mm ²
b	Standard gestanzte	1,5 mm ²	b	Standard gedrehte	1,5 mm ²
c		2,5 mm ²	c		2,5 mm ²
d	Hochstrom gestanzte	1,5 mm ²			
e	Hochstrom gestanzte	2,5 mm ²			

¹⁾ Erläuterung der Bestell-Nr. für die Kontakte siehe Seite 4

¹⁾ Explanation of the Part No. for contacts see page 4

Abisolierlängen siehe S. 208

Stripping length see p. 208

C 146 D
50 + 

250 V~ 10 A/15 A

Steckverbinder
Connectors

Gehäuse siehe Seite 128–131
Housings see page 128–131

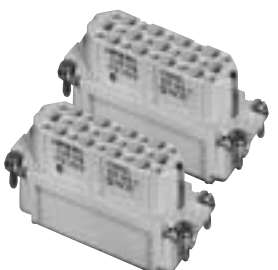
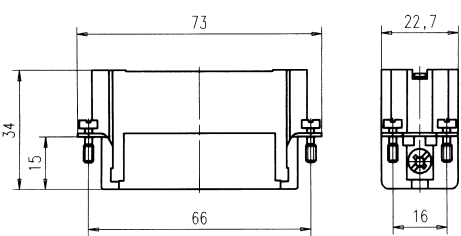
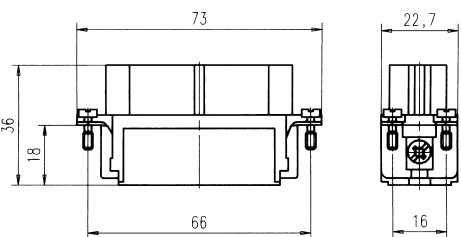
Bezeichnung - Abbildung Description - Figure	Maßzeichnung Drawing	Bestell Nr. / Part No.	
		Stifteinsatz / Male insert	Buchseinsatz / Female insert
Kontakteinsatz Contact insert  	Stifteinsatz Male insert 	C146 10A025 000 2 + C146 10A025 005 2 (für gestanzte Crimpkontakte) (for stamped crimp contacts) C146 10A025 500 2 + C146 10A025 505 2 (für gedrehte Crimpkontakte) (for turned crimp contacts)	C146 10B025 000 2 + C146 10B025 005 2 (für gestanzte Crimpkontakte) (for stamped crimp contacts) C146 10B025 500 2 + C146 10B025 505 2 (für gedrehte Crimpkontakte) (for turned crimp contacts)
	Buchseinsatz Female insert 		

Montageanleitung, Ansicht von Steckverbinder-Anschlussseite / Assembly instructions, view from termination side

Stifteinsatz
Male insert

Buchseinsatz
Female insert

Montageausschnitt (Kontaktträger)
Panel cut out (insert)

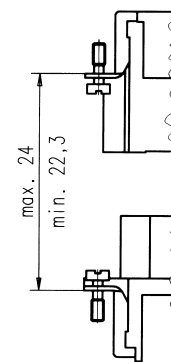
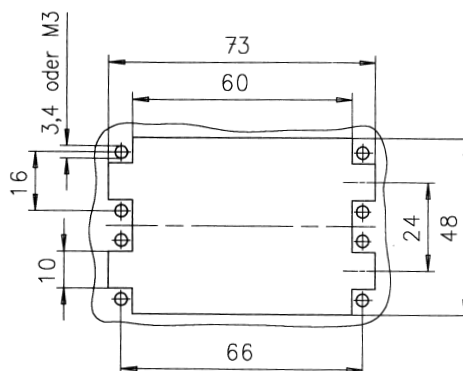
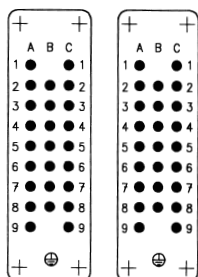
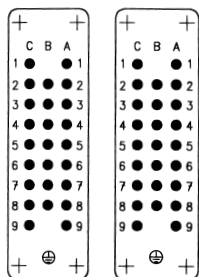

C 146 D 50 +

Crimpkontakte Crimp contacts

Gestanzte Einzelkontakte
Stamped single contacts



Gedrehte Einzelkontakte
Turned single contacts



Gestanzte Bandkontakte für Crimpzangen
Stamped contacts on reel for hand crimping tools



200 / 100 Stück

200 / 100 pcs

Gestanzte Bandkontakte für Crimpmaschinen
Stamped contacts on reel for crimp machines



2000 Stück
(Zuführung links
oder rechts)

2000 pcs
(feeding left or
right hand side)

Lieferform Supplied as	für Leiter- querschnitt for wire gauge	AWG	Stück- zahl Pieces	Bestell Nr. ¹⁾ Stiftkontakt Male contact	Part No. ¹⁾ Buchsenkontakt Female contact	Bestell Nr. ¹⁾ Stiftkontakt Male contact	Part No. ¹⁾ Buchsenkontakt Female contact	
Gestanzte Einzelkontakte / Stamped single contacts				versilbert / silver plating		vergoldet / gold plating		
Standard	0,14 - 0,5 mm ²	26 - 20	100	VN01 016 0003 (1)	VN02 016 0003 (1)	VN01 016 0003 (2)	VN02 016 0003 (2)	
	0,5 - 1,5 mm ²	20 - 16	100	VN01 016 0002 (1)	VN02 016 0002 (1)	VN01 016 0002 (2)	VN02 016 0002 (2)	
	1,5 - 2,5 mm ²	16 - 14	100	VN01 016 0005 (1)	VN02 016 0005 (1)	VN01 016 0005 (2)	VN02 016 0005 (2)	
	Hochstrom High current	0,5 - 1,5 mm ²	20 - 16	VN01 016 0015 (1)	VN02 016 0015 (1)			
	1,5 - 2,5 mm ²	16 - 14	100	VN01 016 0016 (1)	VN02 016 0016 (1)			
Gestanzte Bandkontakte für Crimpzangen / Stamped Contacts on reel for hand crimp tools								
Standard	0,14 - 0,5 mm ²	26 - 20	200	ZN01 016 0003 (1)	ZN02 016 0003 (1)	ZN01 016 0003 (2)	ZN02 016 0003 (2)	
	0,5 - 1,5 mm ²	20 - 16	200	ZN01 016 0002 (1)	ZN02 016 0002 (1)	ZN01 016 0002 (2)	ZN02 016 0002 (2)	
	1,5 - 2,5 mm ²	16 - 14	100	ZN01 016 0005 (1)	ZN02 016 0005 (1)	ZN01 016 0005 (2)	ZN02 016 0005 (2)	
	Hochstrom High current	0,5 - 1,5 mm ²	20 - 16	ZN01 016 0015 (1)	ZN02 016 0015 (1)			
	1,5 - 2,5 mm ²	16 - 14	100	ZN01 016 0016 (1)	ZN02 016 0016 (1)			
Gestanzte Bandkontakte für Crimpmaschinen / Stamped contacts on reel for crimp machines								
Kontaktzuführung rechts Contact feeding right hand side	0,14 - 0,5 mm ²	26 - 20	2000	HN01 016 0003 (1)	HN02 016 0003 (1)	HN01 016 0003 (2)	HN02 016 0003 (2)	
	0,5 - 1,5 mm ²	20 - 16	2000	HN01 016 0002 (1)	HN02 016 0002 (1)	HN01 016 0002 (2)	HN02 016 0002 (2)	
	Standard	1,5 - 2,5 mm ²	16 - 14	2000	HN01 016 0005 (1)	HN02 016 0005 (1)	HN01 016 0005 (2)	HN02 016 0005 (2)
	Hochstrom High current	0,5 - 1,5 mm ²	20 - 16	2000	HN01 016 0015 (1)	HN02 016 0015 (1)		
	1,5 - 2,5 mm ²	16 - 14	2000	HN01 016 0016 (1)	HN02 016 0016 (1)			
Kontaktzuführung links Contact feeding left hand side	0,14 - 0,5 mm ²	26 - 20	2000	TN01 016 0003 (1)	TN02 016 0003 (1)	TN01 016 0003 (2)	TN02 016 0003 (2)	
	0,5 - 1,5 mm ²	20 - 16	2000	TN01 016 0002 (1)	TN02 016 0002 (1)	TN01 016 0002 (2)	TN02 016 0002 (2)	
	Standard	1,5 - 2,5 mm ²	16 - 14	2000	TN01 016 0005 (1)	TN02 016 0005 (1)	TN01 016 0005 (2)	TN02 016 0005 (2)
	Hochstrom High current	0,5 - 1,5 mm ²	20 - 16	2000	TN01 016 0015 (1)	TN02 016 0015 (1)		
	1,5 - 2,5 mm ²	18 - 14	2000	TN01 016 0016 (1)	TN02 016 0016 (1)			
Gedrehte Crimpkontakte / Turned crimp contacts								
Einzelkontakt Single contact	0,14 - 0,37 mm ²	26 - 22	100	VN01 016 0024 (1)C	VN02 016 0024 (1)C	VN01 016 0024 (2)C	VN02 016 0024 (2)C	
	0,5 mm ²	20	100	VN01 016 0025 (1)C	VN02 016 0025 (1)C	VN01 016 0025 (2)C	VN02 016 0025 (2)C	
	0,75 - 1,0 mm ²	20 - 16	100	VN01 016 0026 (1)C	VN02 016 0026 (1)C	VN01 016 0026 (2)C	VN02 016 0026 (2)C	
	1,5 mm ²	16 - 15	100	VN01 016 0027 (1)C	VN02 016 0027 (1)C	VN01 016 0027 (2)C	VN02 016 0027 (2)C	
	2,5 mm ²	14	100	VN01 016 0028 (1)C	VN02 016 0028 (1)C	VN01 016 0028 (2)C	VN02 016 0028 (2)C	
Gestanzte Kontakte Stamped contacts				Gedrehte Kontakte Turned contacts				
Kurve / Curve	Kontakt / Contact	Querschnitt / Wire gauge		Kurve / Curve	Kontakt / Contact	Querschnitt / Wire gauge		
a	Standard gestanzte Standard stamped	0,5 mm ²		a	Standard gedreht Standard turned	0,5 mm ²		
b		1,5 mm ²		b		1,5 mm ²		
c		2,5 mm ²		c		2,5 mm ²		
d	Hochstrom gestanzte High current, stamped	1,5 mm ²						
e		2,5 mm ²						

¹⁾ Erläuterung der Bestell-Nr. für die Kontakte siehe Seite 4

¹⁾ Explanation of the Part No. for contacts see page 4

Abisolierlängen siehe S. 208

Stripping length see p. 208

C 146 D

64 + 

250 V~ 10 A/15 A DIN EN 175 301-801 (DIN 43 652)

Steckverbinder
Connectors

Gehäuse siehe Seite 152–159
Housings see page 152–159

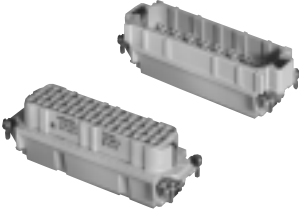
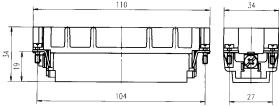
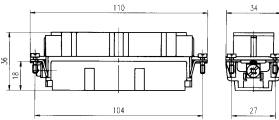
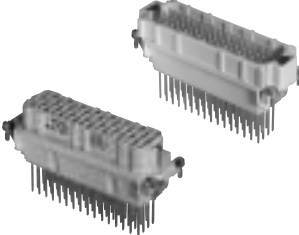
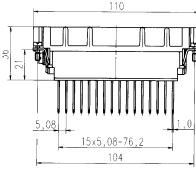
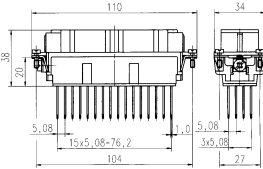
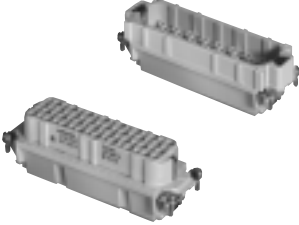
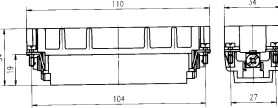
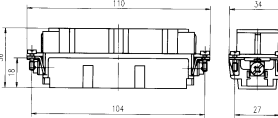
Bezeichnung - Abbildung Description - Figure	Maßzeichnung Drawing	Bestell Nr. / Part No.	
		Stifteinsatz / Male insert	Buchseinsatz / Female insert
Kontakteinsatz Contact insert 	Stifteinsatz Male insert 	C146 10A064 000 2 (für gestanzte Crimpkontakte) (for stamped crimp contacts) C146 10A064 500 2 (für gedrehte Crimpkontakte) (for turned crimp contacts)	C146 10B064 000 2 (für gestanzte Crimpkontakte) (for stamped crimp contacts) C146 10B064 500 2 (für gedrehte Crimpkontakte) (for turned crimp contacts)
	Buchseinsatz Female insert 		
Wickelanschluss ³⁾ Wire wrap termination 	Stifteinsatz Male insert 	Buchseinsatz Female insert 	C146 10A064 009 2 C146 10B064 009 2
Kontakteinsatz 2 X PE Anschluss ¹⁾ Contact insert 2 X PE termination ¹⁾ 	Stifteinsatz Male insert 	C146 10A064 060 2 (für gestanzte Crimpkontakte) (for stamped crimp contacts)	C146 10B064 060 2 (für gestanzte Crimpkontakte) (for stamped crimp contacts)
	Buchseinsatz Female insert 		

Montageanleitung, Ansicht von Steckverbinder-Anschlussseite / Assembly instructions, view from termination side

Stifteinsatz
Male insert

Buchseinsatz
Female insert

Montageausschnitt (Kontaktträger)
Panel cut out (insert)

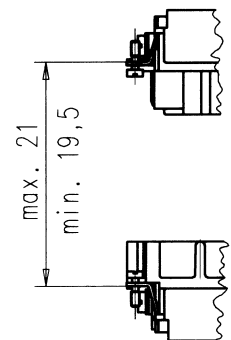
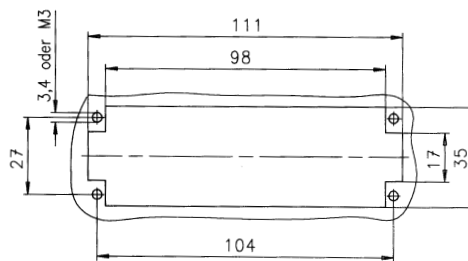
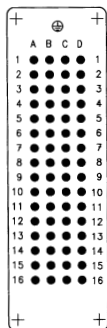
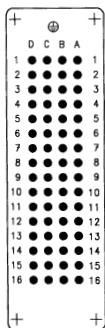

¹⁾ Beim Einbau der Steckverbinder in nicht leitende Gehäuse sind beide Schutzleiter (Ausführung 2 x PE) anzuschließen.
If connectors are mounted in non conductive housings both protective earthing terminals shall be mounted.

²⁾ Für Gehäuse mit niedriger Bauform / for low profile housings

³⁾ IP-Schutzart im Anschlussbereich IP 00
IP-degree of protection on termination side IP 00

C 146 D

64 + 

Crimpkontakte
Crimp contacts

Gestanzte Einzelkontakte
Stamped single contacts



Gedrehte Einzelkontakte
Turned single contacts



Gestanzte Bandkontakte für Crimpzangen
Stamped contacts on reel for hand crimping tools



200 / 100 Stück

200 / 100 pcs

Gestanzte Bandkontakte für Crimpmaschinen
Stamped contacts on reel for crimp machines



2000 Stück
(Zuführung links
oder rechts)

2000 pcs
(feeding left or
right hand side)

D

Lieferform <i>Supplied as</i>	für Leiter- querschnitt <i>for wire gauge</i>	AWG	Stück- zahl <i>Pieces</i>	Bestell Nr. ¹⁾ Stiftkontakt <i>Male contact</i>	Part No. ¹⁾ Buchsenkontakt <i>Female contact</i>	Bestell Nr. ¹⁾ Stiftkontakt <i>Male contact</i>	Part No. ¹⁾ Buchsenkontakt <i>Female contact</i>
Gestanzte Einzelkontakte / <i>Stamped single contacts</i>				versilbert / <i>silver plating</i>		vergoldet / <i>gold plating</i>	
Standard Hochstrom <i>High current</i>	0,14 - 0,5 mm ²	26 - 20	100	VN01 016 0003 (1)	VN02 016 0003 (1)	VN01 016 0003 (2)	VN02 016 0003 (2)
	0,5 - 1,5 mm ²	20 - 16	100	VN01 016 0002 (1)	VN02 016 0002 (1)	VN01 016 0002 (2)	VN02 016 0002 (2)
	1,5 - 2,5 mm ²	16 - 14	100	VN01 016 0005 (1)	VN02 016 0005 (1)	VN01 016 0005 (2)	VN02 016 0005 (2)
	0,5 - 1,5 mm ²	20 - 16	100	VN01 016 0015 (1)	VN02 016 0015 (1)		
	1,5 - 2,5 mm ²	16 - 14	100	VN01 016 0016 (1)	VN02 016 0016 (1)		
Gestanzte Bandkontakte für Crimpzangen / <i>Stamped Contacts on reel for hand crimp tools</i>							
Standard Hochstrom <i>High current</i>	0,14 - 0,5 mm ²	26 - 20	200	ZN01 016 0003 (1)	ZN02 016 0003 (1)	ZN01 016 0003 (2)	ZN02 016 0003 (2)
	0,5 - 1,5 mm ²	20 - 16	200	ZN01 016 0002 (1)	ZN02 016 0002 (1)	ZN01 016 0002 (2)	ZN02 016 0002 (2)
	1,5 - 2,5 mm ²	16 - 14	100	ZN01 016 0005 (1)	ZN02 016 0005 (1)	ZN01 016 0005 (2)	ZN02 016 0005 (2)
	0,5 - 1,5 mm ²	20 - 16	200	ZN01 016 0015 (1)	ZN02 016 0015 (1)		
	1,5 - 2,5 mm ²	16 - 14	100	ZN01 016 0016 (1)	ZN02 016 0016 (1)		
Gestanzte Bandkontakte für Crimpmaschinen / <i>Stamped contacts on reel for crimp machines</i>							
Kontaktzuführung rechts <i>Contact feeding right hand side</i>	0,14 - 0,5 mm ²	26 - 20	2000	HN01 016 0003 (1)	HN02 016 0003 (1)	HN01 016 0003 (2)	HN02 016 0003 (2)
	0,5 - 1,5 mm ²	20 - 16	2000	HN01 016 0002 (1)	HN02 016 0002 (1)	HN01 016 0002 (2)	HN02 016 0002 (2)
	Standard 1,5 - 2,5 mm ²	16 - 14	2000	HN01 016 0005 (1)	HN02 016 0005 (1)	HN01 016 0005 (2)	HN02 016 0005 (2)
	Hochstrom <i>High current</i>	0,5 - 1,5 mm ²	20 - 16	2000	HN01 016 0015 (1)	HN02 016 0015 (1)	
	1,5 - 2,5 mm ²	16 - 14	2000	HN01 016 0016 (1)	HN02 016 0016 (1)		
Kontaktzuführung links <i>Contact feeding left hand side</i>	0,14 - 0,5 mm ²	26 - 20	2000	TN01 016 0003 (1)	TN02 016 0003 (1)	TN01 016 0003 (2)	TN02 016 0003 (2)
	0,5 - 1,5 mm ²	20 - 16	2000	TN01 016 0002 (1)	TN02 016 0002 (1)	TN01 016 0002 (2)	TN02 016 0002 (2)
	Standard 1,5 - 2,5 mm ²	16 - 14	2000	TN01 016 0005 (1)	TN02 016 0005 (1)	TN01 016 0005 (2)	TN02 016 0005 (2)
	Hochstrom <i>High current</i>	0,5 - 1,5 mm ²	20 - 16	2000	TN01 016 0015 (1)	TN02 016 0015 (1)	
	1,5 - 2,5 mm ²	18 - 14	2000	TN01 016 0016 (1)	TN02 016 0016 (1)		
Gedrehte Crimpkontakte / <i>Turned crimp contacts</i>							
Einzelkontakt <i>Single contact</i>	0,14 - 0,37 mm ²	26 - 22	100	VN01 016 0024 (1)C	VN02 016 0024 (1)C	VN01 016 0024 (2)C	VN02 016 0024 (2)C
	0,5 mm ²	20	100	VN01 016 0025 (1)C	VN02 016 0025 (1)C	VN01 016 0025 (2)C	VN02 016 0025 (2)C
	0,75 - 1,0 mm ²	20 - 16	100	VN01 016 0026 (1)C	VN02 016 0026 (1)C	VN01 016 0026 (2)C	VN02 016 0026 (2)C
	1,5 mm ²	16 - 15	100	VN01 016 0027 (1)C	VN02 016 0027 (1)C	VN01 016 0027 (2)C	VN02 016 0027 (2)C
	2,5 mm ²	14	100	VN01 016 0028 (1)C	VN02 016 0028 (1)C	VN01 016 0028 (2)C	VN02 016 0028 (2)C

Gestanzte Kontakte
Stamped contacts

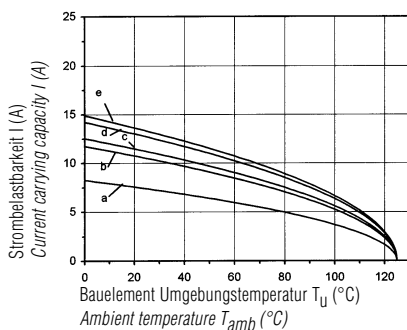

Gedrehte Kontakte
Turned contacts

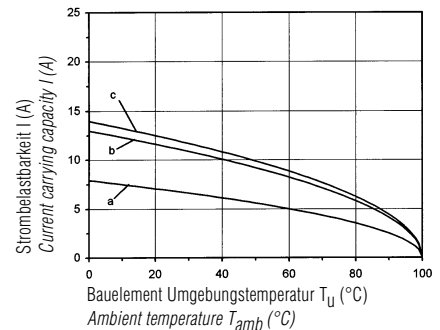

Kurve / <i>Curve</i>	Kontakt / <i>Contact</i>	Querschnitt / <i>Wire gauge</i>	Kurve / <i>Curve</i>	Kontakt / <i>Contact</i>	Querschnitt / <i>Wire gauge</i>
a	Standard gestanzte	0,5 mm ²	a	Standard gedreht	0,5 mm ²
b	Standard gestanzte	1,5 mm ²	b	Standard gedreht	1,5 mm ²
c		2,5 mm ²	c	Standard gedreht	2,5 mm ²
d	Hochstrom gestanzte	1,5 mm ²			
e	Hochstrom gestanzte	2,5 mm ²			

¹⁾ Erläuterung der Bestell-Nr. für die Kontakte siehe Seite 4

¹⁾ Explanation of the Part No. for contacts see page 4

Abisolierlängen siehe S. 208

Stripping length see p. 208

C 146 D
128 + 

250 V~ 10 A/15 A

Steckverbinder
Connectors

Gehäuse siehe Seite 160–163
Housings see page 160–163

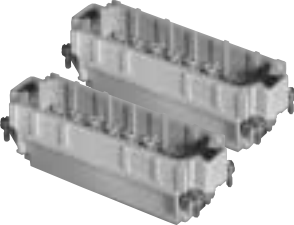
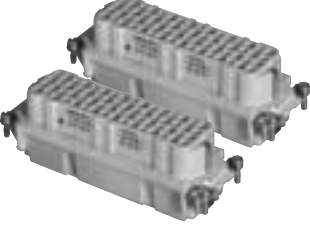
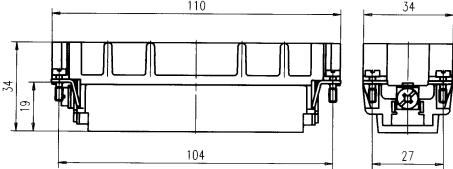
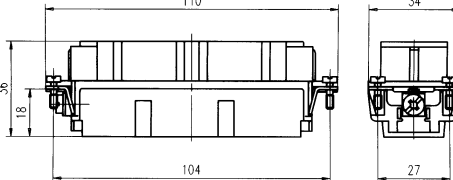
Bezeichnung - Abbildung Description - Figure	Maßzeichnung Drawing	Bestell Nr. / Part No.	
		Stifteinsatz / Male insert	Buchseinsatz / Female insert
Kontakteinsatz Contact insert  	Stifteinsatz Male insert  Buchseinsatz Female insert 	C146 10A064 000 2 + C146 10A064 005 2 (für gestanzte Crimpkontakte) (for stamped crimp contacts) C146 10A064 500 2 + C146 10A064 505 2 (für gedrehte Crimpkontakte) (for turned crimp contacts)	C146 10B064 000 2 + C146 10B064 005 2 (für gestanzte Crimpkontakte) (for stamped crimp contacts) C146 10B064 500 2 + C146 10B064 505 2 (für gedrehte Crimpkontakte) (for turned crimp contacts)

Montageanleitung, Ansicht von Steckverbinder-Anschlussseite / Assembly instructions, view from termination side

Stifteinsatz
Male insert

Buchseinsatz
Female insert

Montageausschnitt (Kontaktträger)
Panel cut out (insert)

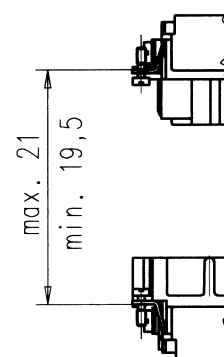
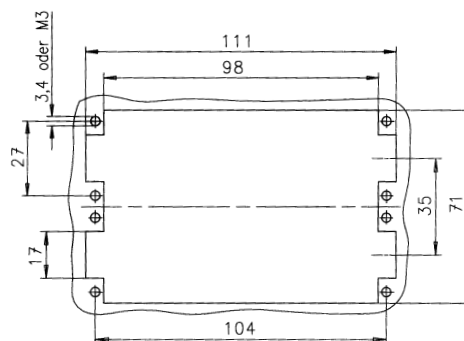
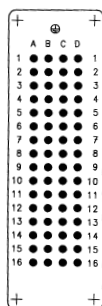
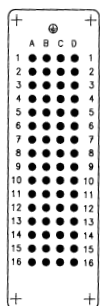
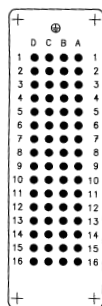
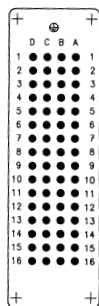

C 146 D 128 +

Crimpkontakte Crimp contacts

Gestanzte Einzelkontakte
Stamped single contacts



Gedrehte Einzelkontakte
Closed turned single contacts



Gestanzte Bandkontakte für Crimpzangen
Stamped contacts on reel for hand crimping tools



200 / 100 Stück
200 / 100 pcs

Gestanzte Bandkontakte für Crimpmaschinen
Stamped contacts on reel for crimp machines



2000 Stück
(Zuführung links
oder rechts)
2000 pcs
(feeding left or
right hand side)

Lieferform Supplied as	für Leiter- querschnitt for wire gauge	AWG	Stück- zahl Pieces	Bestell Nr. ¹⁾ Stiftkontakt Male contact	Part No. ¹⁾ Buchsenkontakt Female contact	Bestell Nr. ¹⁾ Stiftkontakt Male contact	Part No. ¹⁾ Buchsenkontakt Female contact
Gestanzte Einzelkontakte / Stamped single contacts				versilbert / silver plating		vergoldet / gold plating	
Standard Hochstrom High current	0,14 - 0,5 mm ²	26 - 20	100	VN01 016 0003 (1)	VN02 016 0003 (1)	VN01 016 0003 (2)	VN02 016 0003 (2)
	0,5 - 1,5 mm ²	20 - 16	100	VN01 016 0002 (1)	VN02 016 0002 (1)	VN01 016 0002 (2)	VN02 016 0002 (2)
	1,5 - 2,5 mm ²	16 - 14	100	VN01 016 0005 (1)	VN02 016 0005 (1)	VN01 016 0005 (2)	VN02 016 0005 (2)
	0,5 - 1,5 mm ²	20 - 16	100	VN01 016 0015 (1)	VN02 016 0015 (1)		
	1,5 - 2,5 mm ²	16 - 14	100	VN01 016 0016 (1)	VN02 016 0016 (1)		
Gestanzte Bandkontakte für Crimpzangen / Stamped Contacts on reel for hand crimp tools							
Standard Hochstrom High current	0,14 - 0,5 mm ²	26 - 20	200	ZN01 016 0003 (1)	ZN02 016 0003 (1)	ZN01 016 0003 (2)	ZN02 016 0003 (2)
	0,5 - 1,5 mm ²	20 - 16	200	ZN01 016 0002 (1)	ZN02 016 0002 (1)	ZN01 016 0002 (2)	ZN02 016 0002 (2)
	1,5 - 2,5 mm ²	16 - 14	100	ZN01 016 0005 (1)	ZN02 016 0005 (1)	ZN01 016 0005 (2)	ZN02 016 0005 (2)
	0,5 - 1,5 mm ²	20 - 16	200	ZN01 016 0015 (1)	ZN02 016 0015 (1)		
	1,5 - 2,5 mm ²	16 - 14	100	ZN01 016 0016 (1)	ZN02 016 0016 (1)		
Gestanzte Bandkontakte für Crimpmaschinen / Stamped contacts on reel for crimp machines							
Kontaktzuführung rechts Contact feeding right hand side	0,14 - 0,5 mm ²	26 - 20	2000	HN01 016 0003 (1)	HN02 016 0003 (1)	HN01 016 0003 (2)	HN02 016 0003 (2)
	0,5 - 1,5 mm ²	20 - 16	2000	HN01 016 0002 (1)	HN02 016 0002 (1)	HN01 016 0002 (2)	HN02 016 0002 (2)
	1,5 - 2,5 mm ²	16 - 14	2000	HN01 016 0005 (1)	HN02 016 0005 (1)	HN01 016 0005 (2)	HN02 016 0005 (2)
	0,5 - 1,5 mm ²	20 - 16	2000	HN01 016 0015 (1)	HN02 016 0015 (1)		
	1,5 - 2,5 mm ²	16 - 14	2000	HN01 016 0016 (1)	HN02 016 0016 (1)		
Kontaktzuführung links Contact feeding left hand side	0,14 - 0,5 mm ²	26 - 20	2000	TN01 016 0003 (1)	TN02 016 0003 (1)	TN01 016 0003 (2)	TN02 016 0003 (2)
	0,5 - 1,5 mm ²	20 - 16	2000	TN01 016 0002 (1)	TN02 016 0002 (1)	TN01 016 0002 (2)	TN02 016 0002 (2)
	1,5 - 2,5 mm ²	16 - 14	2000	TN01 016 0005 (1)	TN02 016 0005 (1)	TN01 016 0005 (2)	TN02 016 0005 (2)
	0,5 - 1,5 mm ²	20 - 16	2000	TN01 016 0015 (1)	TN02 016 0015 (1)		
	1,5 - 2,5 mm ²	18 - 14	2000	TN01 016 0016 (1)	TN02 016 0016 (1)		
Gedrehte Crimpkontakte / Turned crimp contacts							
Einzelkontakt Single contact	0,14 - 0,37 mm ²	26 - 22	100	VN01 016 0024 (1)C	VN02 016 0024 (1)C	VN01 016 0024 (2)C	VN02 016 0024 (2)C
	0,5 mm ²	20	100	VN01 016 0025 (1)C	VN02 016 0025 (1)C	VN01 016 0025 (2)C	VN02 016 0025 (2)C
	0,75 - 1,0 mm ²	20 - 16	100	VN01 016 0026 (1)C	VN02 016 0026 (1)C	VN01 016 0026 (2)C	VN02 016 0026 (2)C
	1,5 mm ²	16 - 15	100	VN01 016 0027 (1)C	VN02 016 0027 (1)C	VN01 016 0027 (2)C	VN02 016 0027 (2)C
	2,5 mm ²	14	100	VN01 016 0028 (1)C	VN02 016 0028 (1)C	VN01 016 0028 (2)C	VN02 016 0028 (2)C

Gestanzte Kontakte Stamped contacts

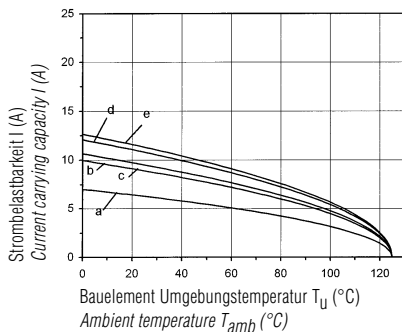

Gedrehte Kontakte Turned contacts

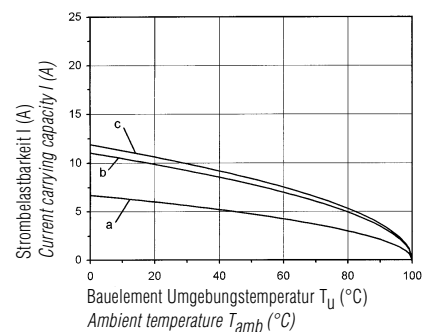

Kurve / Curve	Kontakt / Contact	Querschnitt / Wire gauge	Kurve / Curve	Kontakt / Contact	Querschnitt / Wire gauge
a	Standard gestanzte	0,5 mm ²	a	Standard gedrehte	0,5 mm ²
b	Standard gestanzte	1,5 mm ²	b	Standard gedrehte	1,5 mm ²
c		2,5 mm ²	c		2,5 mm ²
d	Hochstrom gestanzte	1,5 mm ²			
e	Hochstrom gestanzte	2,5 mm ²			

¹⁾ Erläuterung der Bestell-Nr. für die Kontakte siehe Seite 4

¹⁾ Explanation of the Part No. for contacts see page 4

Abisolierlängen siehe S. 208

Stripping length see p. 208

Modifizierte Kontaktanordnung für Bemessungsspannungen von 400 V

Modified contact arrangement for rated voltages of 400 V

- = Arbeitskontakt
full load contact
- = Leerstelle
unoccupied

(15) → 7 + ⊕

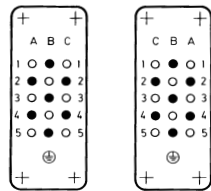

Buchseinsatz Female insert Stifteinsatz Male insert

(25) → 11 + ⊕

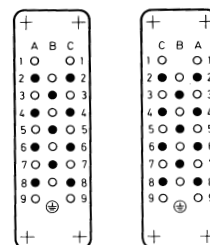

Buchseinsatz Female insert Stifteinsatz Male insert

(40) → 20 + ⊕

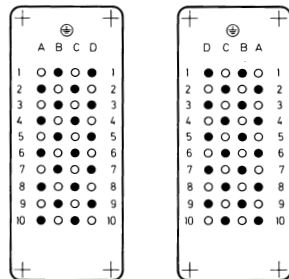

Buchseinsatz Female insert Stifteinsatz Male insert

(64) → 32 + ⊕

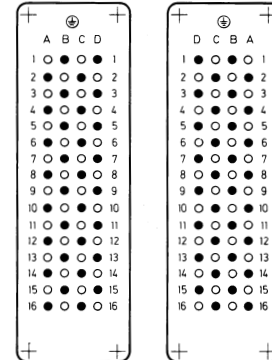

Buchseinsatz Female insert Stifteinsatz Male insert

Lösen der Kontakte ¹⁾

Removal of contacts ¹⁾

Demontage von Steckseite / front releas

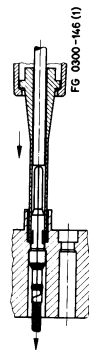

- Prinzip:
- gestanzte Stiftkontakte
Stamped male contacts
 - gedrehte Kontakte
Turned contacts

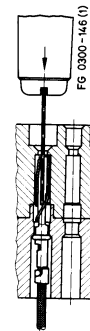

- gestanzte Buchsenkontakte
Stamped female contacts

Werkzeuge / Tools ¹⁾



Bezeichnung / Description	für Leiterquerschnitt for wire gauge	Kontaktaufnahme / Contact locator	Bestell Nr. / Part No. Crimpbacken / Crimping dies	Werkzeuge / Tools
Lösewerkzeug für Kontakte Removal tool for contacts	—	—	—	FG 0300 146 1
Service Crimpzange Service crimping tool	0,14 - 0,5 mm ² 0,5 - 1,5 mm ²	—	—	TA 0100 146
Crimpzange für Einzelkontakte Crimping tool for single contacts	0,14 - 0,5 mm ² 0,5 - 1,5 mm ² 1,5 - 2,5 mm ²	TA 0001 146 000 1 TA 0002 146 000 1 TA 0007 146 000 3	TA 0000 202 TA 0000 163 TA 0000 141	TA 0000 TA 0500

¹⁾ Weitere Informationen siehe Katalog „Werkzeuge“ / Further information see catalogue „Tools“

C 146 DD

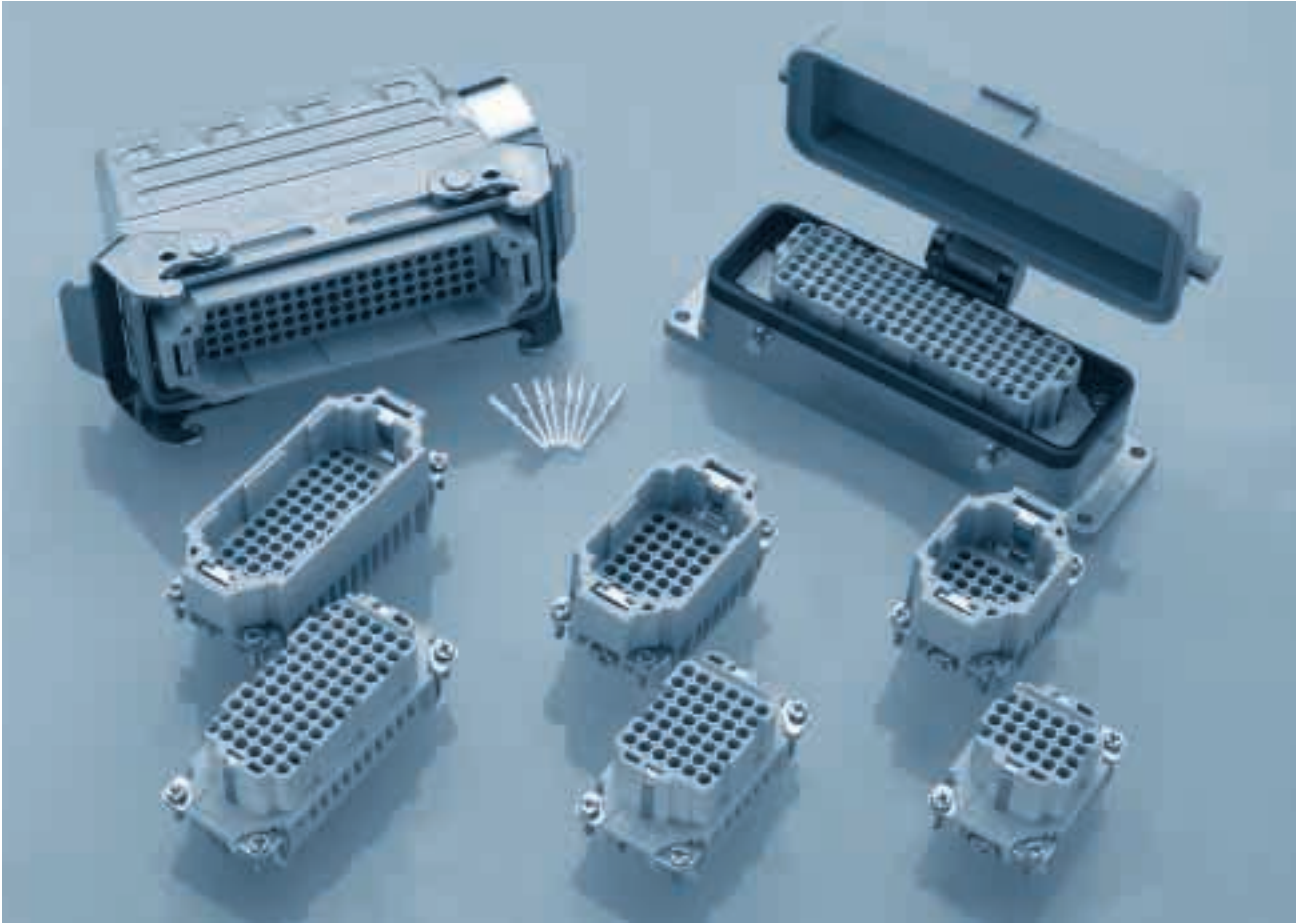
DD

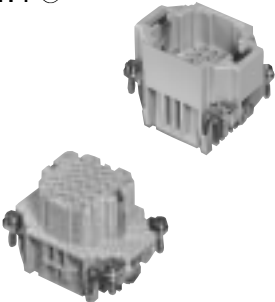
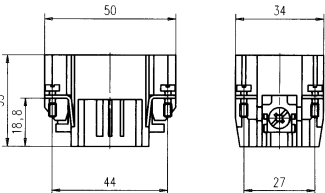
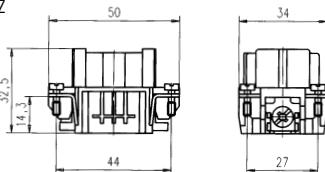
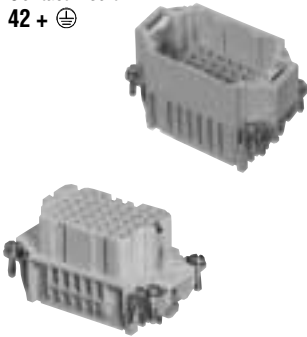
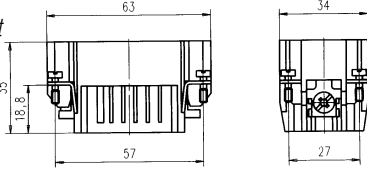
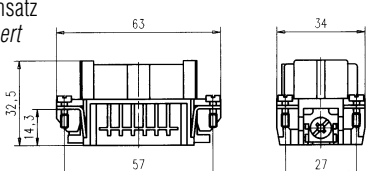
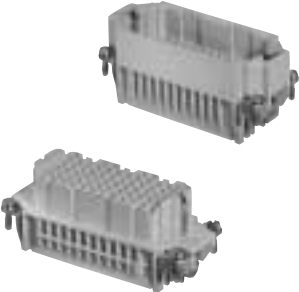
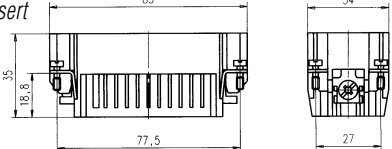
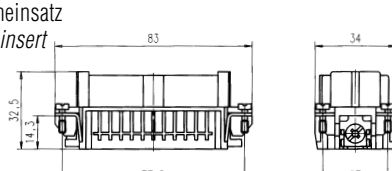
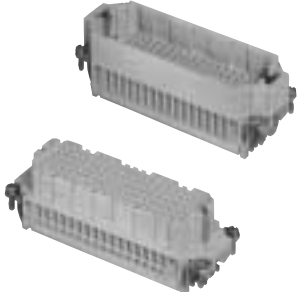
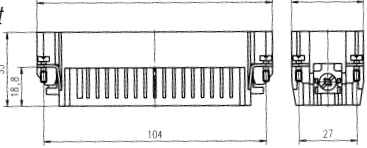
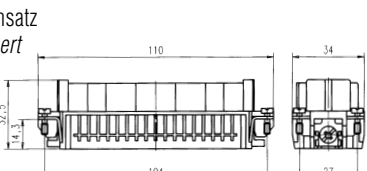

Hauptmerkmale		Main characteristics	
<ul style="list-style-type: none"> • Bemessungsspannung 250 V • Bemessungsstrom 8 A ... 9 A • Anschlussart: crimpen • Polzahl: 24, 42, 72, 108 		<ul style="list-style-type: none"> • Rated voltage 250 V • Rated current 8 A ... 9 A • Termination: crimp • Number of contacts: 24, 42, 72, 108 	
Zulassungen / Approvals	Prüfstelle / Testhouse	Kennwerte / Characteristics	Zulassungs-Nummer / Approval-No.
SEV		250 V, 10 A	
UL		600 V, 8,5 A	E 63093
CSA		600 V, 20 A	LR 700721
<p>Zulassungen beziehen sich im allgemeinen auf repräsentative Ausführungen der Steckverbinderserie. Prüfumfang und Prüfvorschrift auf Anfrage.</p>		<p><i>In general approvals refer to representative versions of the connector series. Extent and specification of tests upon request.</i></p>	

Bezeichnung - Abbildung Description - Figure	Maßzeichnung Drawing	Bestell Nr. / Part No.	
		Stifteinsatz / Male insert	Buchseneinsatz / Female insert
Kontakteinsatz Contact insert 24 + ⊕ 	Stifteinsatz Male insert  Buchseneinsatz Female insert 	C146 10A024 000 9	C146 10B024 000 9
Kontakteinsatz Contact insert 42 + ⊕ 	Stifteinsatz Male insert  Buchseneinsatz Female insert 	C146 10A042 000 9	C146 10B042 000 9
Kontakteinsatz Contact insert 72 + ⊕ 	Stifteinsatz Male insert  Buchseneinsatz Female insert 	C146 10A072 000 9	C146 10B072 000 9
Kontakteinsatz Contact insert 108 + ⊕ 	Stifteinsatz Male insert  Buchseneinsatz Female insert 	C146 10A108 000 9	C146 10B108 000 9

C 146 DD

Steckverbinder
Connectors

Crimpkontakte
Crimp contacts

Gedrehte 1,6 mm Kontakte
Turned 1,6 mm contacts

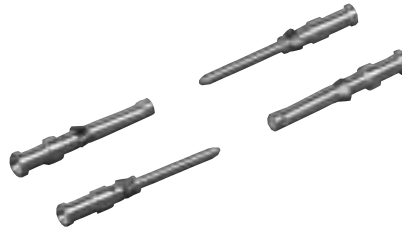

DD

Bezeichnung - Abbildung Description - Figure	Maßzeichnung Drawing	Bestell Nr. / Part No.	
		Stifteinsatz / Male insert	Buchseinsatz / Female insert
Kontakteinsatz Contact insert 216 +	Stifteinsatz Male insert Buchseinsatz Female insert	C146 10A108 000 9 + C146 10A108 005 9	C146 10B108 000 9 + C146 10B108 005 9

Lieferform Supplied as	für Leiter- querschnitt for wire gauge	AWG	Stück- zahl Pieces	Bestell Nr. ¹⁾ Stiftkontakt Male contact	Part No. ¹⁾ Buchsenkontakt Female contact	Bestell Nr. ¹⁾ Stiftkontakt Male contact	Part No. ¹⁾ Buchsenkontakt Female contact
				versilbert / silver plating		vergoldet / gold plating	
Einzelkontakt Single contact	0,14 - 0,37 mm ²	26 - 22	100	VN01 016 0024 (1)C	VN02 016 0024 (1)C	VN01 016 0024 (2)C	VN02 016 0024 (2)C
	0,5 mm ²	20	100	VN01 016 0025 (1)C	VN02 016 0025 (1)C	VN01 016 0025 (2)C	VN02 016 0025 (2)C
	0,75 - 1,0 mm ²	20 - 16	100	VN01 016 0026 (1)C	VN02 016 0026 (1)C	VN01 016 0026 (2)C	VN02 016 0026 (2)C
	1,5 mm ²	16 - 15	100	VN01 016 0027 (1)C	VN02 016 0027 (1)C	VN01 016 0027 (2)C	VN02 016 0027 (2)C
	2,5 mm ²	14	100	VN01 016 0028 (1)C	VN02 016 0028 (1)C	VN01 016 0028 (2)C	VN02 016 0028 (2)C

Montageanleitung, Steckbild / Assembly instruction, pin layout

Stifteinsatz
Male insert

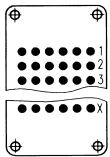

Buchseinsatz
Female insert

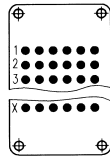

X = 4 (24 pol.)
7 (42 pol.)
12 (72 pol.)
18 (108 pol.)

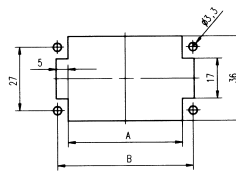

Pol	A	B
24	35	44
42	48	57
72	69	77,5
108	95	104

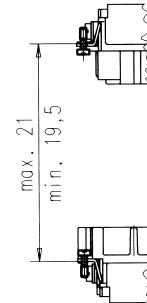

Derating Kurven / Derating curves

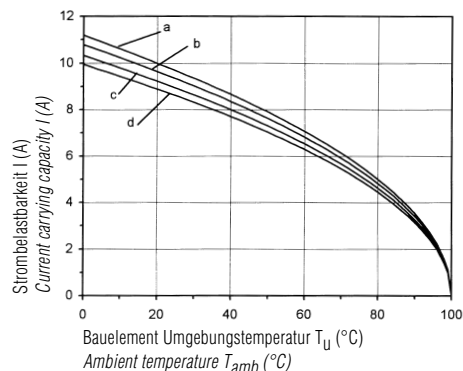
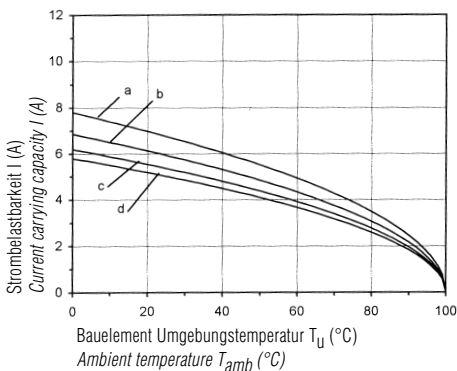

Kurve / Curves	Polzahl / Contacts	Querschnitt / Wire gauge	Kurve / Curves	Polzahl / Contacts	Querschnitt / Wire gauge
a	24	0,75 mm ²	a	24	1,5 mm ²
b	42	0,75 mm ²	b	42	1,5 mm ²
c	72	0,75 mm ²	c	72	1,5 mm ²
d	108	0,75 mm ²	d	108	1,5 mm ²

¹⁾ Erläuterung der Bestell-Nr. für die Kontakte siehe Seite 4
¹⁾ Explanation of the Part No. for contacts see page 4

Abisolierlängen siehe S. 208
Stripping length see p. 208





Allgemeine Kennwerte	General Characteristics	Norm / Standard	Wert / Value			
Polzahl	Number of contacts		24 + ☹	42 + ☹	72 + ☹	108 + ☹
Anschluss technik	Termination technique		crimpen / crimp			
Anschlussquerschnitt	Wire gauge		0,14 mm ² - 2,5 mm ²			
Brennbarkeit	Flammability	UL 94	V-0			
Elektrische Kennwerte	Electrical Characteristics					
Bemessungsspannung	Rated voltage	IEC 60664-1	250 V (600 V UL / CSA)			
Verschmutzungsgrad	Pollution degree	IEC 60664-1	2 (3 in gestecktem + verriegeltem Zustand) 2 (3 mated and locked)			
Überspannungskategorie	Installation (overvoltage) category	IEC 60664-1	III			
Isolierstoffgruppe	Material group	IEC 60664-1	III b			
Bemessungs-Stoßspannung	Rated impulse withstand voltage	IEC 60664-1	4 kV			
Spannungsfestigkeit	Voltage proof	IEC 60512-2; Test 4 a	2 kV			
Strombelastbarkeit	Current carrying capacity	IEC 60512-3; Test 5 b	siehe Derating Kurven / see derating curves			
Bemessungsstrom T _U = 40 °C	Rated current T _{amb} = 40 °C		9 A	9 A	8 A	8 A
Durchgangswiderstand	Contact resistance	IEC 60512-2; Test 2 a	≤ 5 m Ω			
Isolationswiderstand	Insulation resistance	IEC 60512-2; Test 3 a	≥ 10 ¹² Ω ¹⁾			
Luftstrecke	Clearance	VDE 0627	> 2,5 mm			
Kriechstrecke	Creepage	VDE 0627	> 4 mm			
Klimatische Kennwerte	Climatical Characteristics					
Prüfklasse	Climatic category	IEC 60068-1	40 / 100 / 21			
Obere Grenztemperatur	Upper temperature	IEC 60512-6; Test 11 i	+ 100 °C / 1000 h			
Untere Grenztemperatur	Lower temperature	IEC 60512-6; Test 11 i	- 40 °C / 16 h			
Mechanische Kennwerte	Mechanical Characteristics					
Gewicht Stifteinsatz	Weight pin insert		44 g	50 g	63 g	86 g
IP-Schutzart Stifteinsatz	IP-degree of protection pin insert	IEC 60529	ungesteckt/unmated IP00		gesteckt/mated IP20	
IP-Schutzart Buchseneinsatz	IP-degree of protection socket insert	IEC 60529	ungesteckt/unmated IP20		gesteckt/mated IP20	
Gewicht Buchseneinsatz	Weight socket insert		41 g	50 g	67 g	88 g
Mechanische Lebensdauer	Mechanical operation	IEC 60512-5; Test 9 a	≥ 500 Steckzyklen / mating cycles			
Werkstoffe	Materials					
Kontakteinsatz	Insert		PBT			
Kontakte	Contacts		CuZn (Messing / brass)			
Kontakt oberfläche	Contact plating		Ag			
Farbe	Colour		grau / grey			

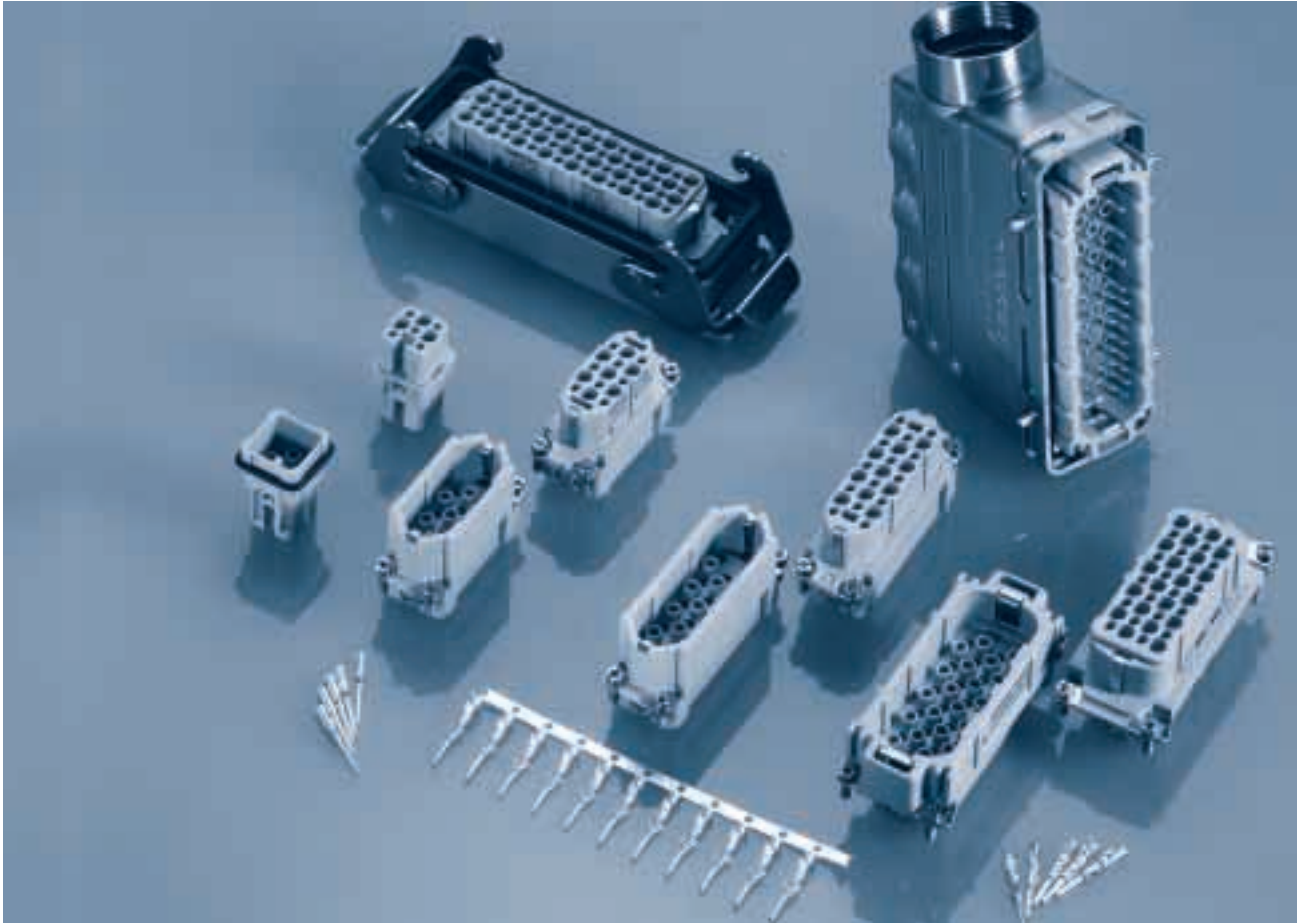

¹⁾ Bei Beanspruchung > 10¹⁰ Ω / Under operating conditions > 10¹⁰ Ω





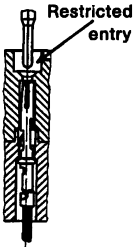
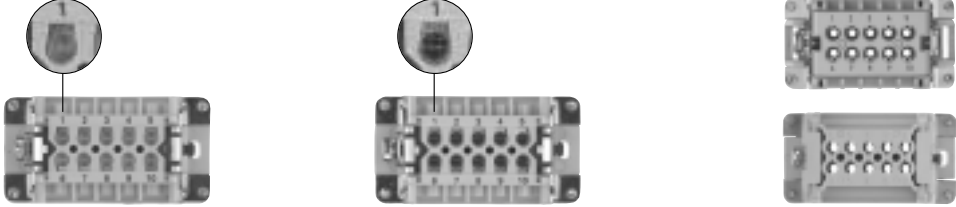
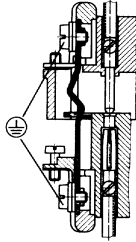

C 146 E

E

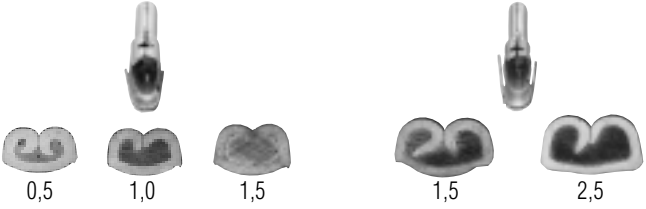

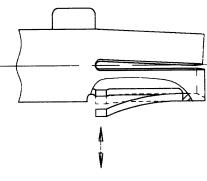
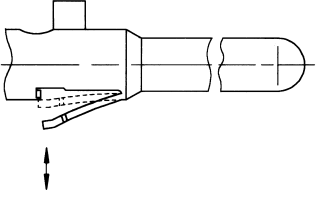
Hauptmerkmale		Main characteristics	
<ul style="list-style-type: none"> • Bemessungsspannung 400 V • Bemessungsstrom 16 A ... 22 A • Anschlussart: schrauben oder crimpen • Kontaktdurchmesser 2,5 mm • Polzahl: 6, 10, 16, 24, 48 		<ul style="list-style-type: none"> • Rated voltage 400 V • Rated current 16 A ... 22 A • Termination: screw or crimp • Contact diameter 2,5 mm • Numbers of contacts: 6, 10, 16, 24, 48 	
Zulassungen / Approvals Prüfstelle / Testhouse		Kennwerte / Characteristics	Zulassungs-Nummer / Approval-No.
SEV		400 V, 16 A	
UL		600 V, 10 A	E 63093
CSA		600 V, 15 A	48932
DB		400 V, 16 A	BN 74 018
<p>Zulassungen beziehen sich im allgemeinen auf repräsentative Ausführungen der Steckverbinderserie. Prüfumfang und Prüfvorschrift auf Anfrage.</p>		<p><i>In general approvals refer to representative versions of the connector series. Extent and specification of tests upon request.</i></p>	

<p>Allgemeine Hinweise</p>  <p>General information</p>	<ul style="list-style-type: none"> • Kontakteinsätze ohne Crimpkontakte (bei Kontakteinsatz mit Crimpanschluss). • Steckverbinder der Serie C 146 E dürfen unter Spannung, jedoch nicht unter Strom betätigt werden. Werden die Steckverbinder unter Last gesteckt und getrennt, ist der Strom auf 10 % des Bemessungsstromes zu begrenzen. • Crimpwerkzeuge und Verarbeitungshinweise siehe separater Katalog „Werkzeuge“. • Für die Einsätze der Serie C 146 E können sowohl niedrige, wie auch hohe Gehäusebauformen verwendet werden. • Bei Verwendung von Aderendhülsen, sind Schraubanschlüsseinsätze ohne Drahtschutz zu bevorzugen. <ul style="list-style-type: none"> • <i>Contact inserts without crimp contacts.</i> • <i>Connectors series C146 E may be engaged or disengaged when live but without electrical load. If these connectors are mated or unmated under load, the load shall be reduced to 10 % of the rated current.</i> • <i>Crimping tools and processing instructions see separate catalogue „Tools“.</i> • <i>Low and high profile housings are usable.</i> • <i>If wire ferrule are used, screw terminals without wire protection are preferred.</i>
<p>Nicht genormte Steckverbinder, aber:</p> <p>No standard for this series, but:</p>	<p>Steck- und austauschbar mit Fremdfabrikaten Gehäuse nach DIN EN 175 301 - 801</p> <p>a) Kontakteinsatz/Kontakteinsatz 6, 10, 16, 24 pol. b) Kontakteinsatz/Gehäuse 6, 10, 16, 24 pol.</p> <p><i>Interchangeable with other products</i> <i>Housings are designed according to DIN EN 175 301 - 801</i></p> <p>a) <i>contact insert to contact insert 6, 10, 16, 24 contacts</i> b) <i>contact insert to housing 6, 10, 16, 24 contacts</i></p>
<p>Hoher Schutz vor Fehlsteckungen</p> <p>High protection against mismatching</p>	<p>Buchsenkontakteinsatz mit trichterförmiger, verengter Stecköffnung. (Hohe Steck- und Kontaktsicherheit)</p> <p><i>Female inserts with funnel shaped contact entry avoids mismatching.</i></p> 
<p>Kontakteinsätze für Schraubanschluss, Schraubanschluss mit Drahtschutz und für Crimptechnik</p> <p>Contact inserts for screw termination, screw termination with wire protection and for crimp termination</p>	 <p>Schraubanschluss <i>Screw termination</i></p> <p>Schraubanschluss mit Drahtschutz <i>Screw termination with wire protection</i></p> <p>Crimpanschluss <i>Crimp termination</i></p>
<p>Voreilender Schutzkontakt</p> <p>First-to-mate last-to-break protective ground contact</p>	
<p>Große Gehäuseauswahl in 2 Bauhöhen (ab Seite 132)</p> <p>Large range of housings in 2 different heights (see page 132)</p>	

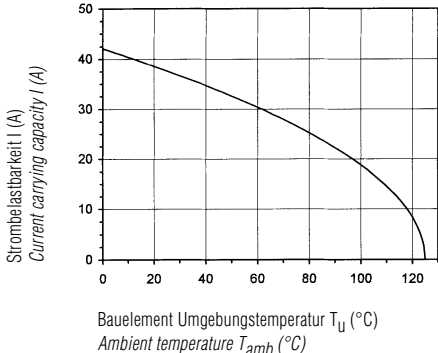
<p>Großer Crimpbereich Gasdichte Verbindung (Kaltverschweißung)</p> <p><i>Large range of wire gauges Gas-tight (coldwelding)</i></p>	<p>.N01 025 0001 (1) ¹⁾ .N01 025 0010 (1) ¹⁾</p>  <p>0,5 1,0 1,5 1,5 2,5</p>		
<p>Gestanzte Crimpkontakte mit Isolierungshalterung um mechanische Beanspruchungen von der Crimpverbindung fernzuhalten</p> <p><i>Stamped crimp contacts with insulation crimp to absorb mechanical stress from the crimped connection</i></p>	 <p>Isolierungshalterung <i>Insulation grip</i></p>		
<p>Mechanischer Rasthakenanschlag bei Buchsen- und Stiftkontakt</p> <p><i>Mechanical retention spring stop on female and male contact</i></p>	<p>Buchsenkontakt <i>Female contact</i></p> 	<p>Stiftkontakt <i>Male contact</i></p> 	
<p>Kostengünstige, einfache Verarbeitung. Werkzeuge siehe Katalog „Werkzeuge“</p> <p><i>Economical and easy processing. Tools see catalogue „Tools“</i></p>	 <p>Einzel-Fertigung <i>Single production</i></p>	 <p>Kleinserie <i>Small series</i></p>	 <p>Serie <i>Series</i></p>
<p>Hohe Strombelastbarkeit (siehe Derating Kurven)</p> <p><i>High current carrying capacity (see derating curves)</i></p>	<p>Beispiel Einzelkontakt, Anschlussquerschnitt 2,5 mm²</p> <p><i>Example single contact, wire gauge 2.5 mm²</i></p>  <p>Strombelastbarkeit I (A) <i>Current carrying capacity I (A)</i></p> <p>Bauelement Umgebungstemperatur T_U (°C) <i>Ambient temperature T_{amb} (°C)</i></p>		

¹⁾ Erläuterung der Bestell-Nr. für die Kontakte siehe Seite 4 / *Explanation of the Part No. for contacts see page 4*



Kontakteinsätze / Connector inserts

Allgemeine Kennwerte	General Characteristics	Norm / Standard	Wert / Value				
Polzahl	Number of contacts		6 + ⊕	10 + ⊕	16 + ⊕	24 + ⊕	48 + ⊕
Anschlussstechnik	Termination technique		crimpen / schrauben		crimp / screw		
Anschlussquerschnitt: crimpen, schrauben	Wire gauge: crimp, screw		0,5 - 4 mm ²		0,25 - 2,5 mm ²		
Brennbarkeit	Flammability	UL 94	V-0				
Elektrische Kennwerte	Electrical Characteristics						
Bemessungsspannung	Rated voltage	IEC 60664-1	400 V (600 V UL / CSA ²⁾)				
Verschmutzungsgrad	Pollution degree	IEC 60664-1	3				
Isolierstoffgruppe	Material group	IEC 60664-1	III b				
Überspannungskategorie	Installation (overvoltage) category	IEC 60664-1	III				
Bemessungs-Stoßspannung	Rated impulse withstand voltage	IEC 60664-1	6,0 kV				
Spannungsfestigkeit	Voltage proof	IEC 60512-2; Test 4 a	2,8 kV				
Strombelastbarkeit	Current carrying capacity	IEC 60512-2; Test 5 b	siehe Derating Kurven / see derating curves				
Bemessungsstrom (T _U = 40 °C)	Rated current (T _{amb} = 40 °C)		22 A	19 A	19 A	18 A	18 A
Durchgangswiderstand	Contact resistance	IEC 60512-2; Test 2 a	< 5 mΩ				
Isolationswiderstand	Insulation resistance	IEC 60512-2; Test 2 a	≥ 10 ¹² Ω ¹⁾				
Luftstrecke	Clearance	DIN VDE 0627	> 4,0 mm				
Kriechstrecke	Creepage	DIN VDE 0627	> 6,3 mm				
Klimatische Kennwerte	Climatical Characteristics						
Prüfklasse	Climatic category	IEC 60068-1	40 / 125 / 21				
Obere Grenztemperatur	Upper temperature	IEC 60512-6; Test 11 i	+ 125 °C / 1000 h				
Untere Grenztemperatur	Lower temperature	IEC 60512-6; Test 11 i	- 40 °C / 16 h				
Mechanische Kennwerte	Mechanical Characteristics						
Gesamt Steck- und Ziehkraft crimpen schrauben	Insertion and withdrawal forces: crimp screw	IEC 60512-7; Test 13 b	10-20 N 20-30 N	30-40 N 40-50 N	45-60 N 80-100 N	70-100 N 100-120 N	140-200 N 200-240 N
³⁾ IP-Schutzart Stifteinsatz	IP-degree of protection pin insert	IEC 60529	ungesteckt/unmated IP00		gesteckt/mated IP20		
³⁾ IP-Schutzart Buchseneinsatz	IP-degree of protection socket insert	IEC 60529	ungesteckt/unmated IP20		gesteckt/mated IP20		
Gewicht: Stifteinsatz crimp (gestanzte Kontakte) Buchseneinsatz crimp (gest. Kontakte) Stifteinsatz schraub Buchseneinsatz schraub	Weight: male insert crimp (f. stamped contacts) female insert crimp (f. stamped contacts) male insert screw female insert screw		33 g 33 g 43 g 43 g	39 g 39 g 57 g 57 g	45 g 49 g 78 g 78 g	55 g 62 g 105 g 106 g	110 g 124 g 210 g 212 g
Mechanische Lebensdauer	Mechanical operation	IEC 60512-5; Test 9 a	> 500 Steckzyklen / mating cycles				
Werkstoffe	Materials						
Kontakteinsatz	Insert		PC GV (Polycarbonat)				
Schraubkontakte	Screw contacts		CuZn (Messing/brass)				
Kontaktoberfläche	Contact plating		Ag (silber/silver)				
Farbe	Colour		grau / grey				

¹⁾ Bei Beanspruchung > 10¹⁰ Ω / Under operating conditions 10¹⁰ Ω ²⁾ Hinweisschild für CSA-Anwendungen siehe Seite 186 / Label for CSA application see page 186

³⁾ IP-Schutzart im Anschlussbereich der Schraubausführung IP 10 / IP-degree of protection on termination side of screw version IP 10

C 146 E

Technische Daten Characteristics



Gestanzte Crimpkontakte / Stamped crimp contacts

Elektrische Kennwerte	Electrical Characteristics		
Durchgangswiderstand	Contact resistance	IEC 60512-2; Test 2 a	< 5 m Ω
Kapazität Kontakt-Kontakt	Capacity contact-contact	IEC 60512-9; Test 22 a	≥ 2 p F
Kapazität Kontakt-Gehäuse	Capacity contact-housing	IEC 60512-9; Test 22 a	≥ 3,2 p F
Mechanische Kennwerte	Mechanical Characteristics		
Mechanische Lebensdauer	Mechanical operation	IEC 60512-5; Test 9 a	≥ 500 Steckzyklen / mating cycles
Werkstoffe	Materials		
Stiftkontakt	Male contact		CuZn (Messing / brass)
Buchsenkontakt	Female contact		CuSn (Zinnbronze / Tin bronze)
Kontaktoberfläche	Contact plating		Ag

Gedrehte Crimpkontakte / Turned crimp contacts

Elektrische Kennwerte	Electrical Characteristics		
Durchgangswiderstand	Contact resistance	IEC 60512-2	≤ 5 m Ω
Klimatische Kennwerte	Climatical Characteristics		
Obere Grenztemperatur	Upper temperature	IEC 60512-6	+ 100 °C
Untere Grenztemperatur	Lower temperature	IEC 60512-6	- 40 °C
Mechanische Kennwerte	Mechanical Characteristics		
Mechanische Lebensdauer	Mechanical operation	IEC 60512-5; Test 9 a	≥ 500 Steckzyklen / mating cycles
Werkstoffe	Materials		
Stiftkontakt	Male contact		CuZn (Messing / brass)
Buchsenkontakt	Female contact		CuZn (Messing / brass)
Kontaktoberfläche	Contact plating		Ag

C 146 E

6 + 

Steckverbinder
Connectors

400 V~ Kontakteinsatz für gestanzte Kontakte /
Contact insert for stamped contacts





500 V~ Kontakteinsatz für Schraubanschluss und für gedrehte Kontakte /
Contact insert for screw termination and for turned contacts

16 / 22 A

Gehäuse siehe Seite 132–135

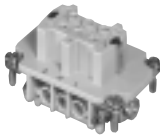
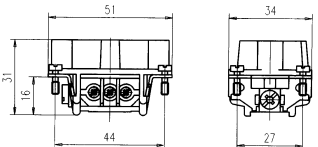
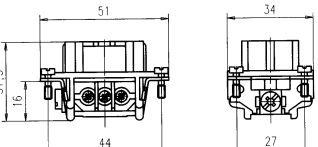
Housings see page 132–135

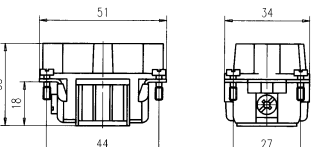
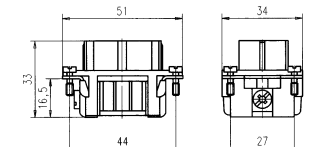
E

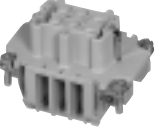
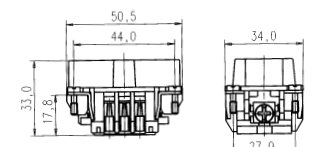
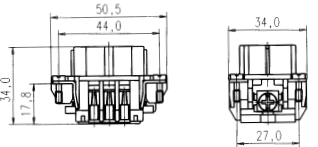
Bezeichnung - Abbildung Description - Figure	Maßzeichnung Drawing	Bestell Nr. / Part No.	
		Stifteinsatz / Male insert	Buchseinsatz / Female insert
Kontakteinsatz Schraubanschluss Contact insert screw termination  	Stifteinsatz Male insert  Buchseinsatz Female insert 	C146 10A006 002 1	C146 10B006 002 1
Kontakteinsatz für gestanzte Kontakte Contact insert for stamped contacts  	Stifteinsatz Male insert  Buchseinsatz Female insert 	C146 10A006 000 1	C146 10B006 000 1
Kontakteinsatz für gedrehte Kontakte Contact insert for turned contacts  	Stifteinsatz Male insert  Buchseinsatz Female insert 	C146 10A006 500 1	C146 10B006 500 1

C 146 E

6 + 

Crimpkontakte
Crimp contacts

Gestanzte Einzelkontakte
Stamped single contacts



Gedrehte Einzelkontakte
Turned single contacts



Gestanzte Bandkontakte für Crimpzangen
Stamped contacts on reel for hand crimping tools



200 / 100 Stück
200 / 100 pcs

Gestanzte Bandkontakte für Crimpmaschinen
Stamped contacts on reel for crimp machines



2000 Stück
(Zuführung links oder rechts)
2000 pcs
(feeding left or right hand side)

Lieferform <i>Supplied as</i>	für Leiterquerschnitt <i>for wire gauge</i>	AWG	Stückzahl <i>Pieces</i>	Bestell Nr. ¹⁾ Stiftkontakt <i>Male contact</i>	Part No. ¹⁾ Buchsenkontakt <i>Female contact</i>	Bestell Nr. ¹⁾ Stiftkontakt <i>Male contact</i>	Part No. ¹⁾ Buchsenkontakt <i>Female contact</i>
Gestanzte Einzelkontakte / <i>Stamped single contacts</i>				versilbert / <i>silver plating</i>		vergoldet / <i>gold plating</i>	
	0,5 - 1,5 mm ²	20 - 16	100	VN01 025 0001 (101)	VN02 025 0001 (101)	VN01 025 0001 (102)	VN02 025 0001 (102)
	1,5 - 2,5 mm ²	16 - 14	100	VN01 025 0010 (101)	VN02 025 0010 (101)	VN01 025 0010 (102)	VN02 025 0010 (102)
Gestanzte Bandkontakte für Crimpzangen / <i>Stamped Contacts on reel for hand crimp tools</i>							
	0,5 - 1,5 mm ²	20 - 16	200	ZN01 025 0001 (1)	ZN02 025 0001 (1)	ZN01 025 0001 (2)	ZN02 025 0001 (2)
	1,5 - 2,5 mm ²	16 - 14	100	ZN01 025 0010 (1)	ZN02 025 0010 (1)	ZN01 025 0010 (2)	ZN02 025 0010 (2)
Gestanzte Bandkontakte für Crimpmaschinen / <i>Stamped contacts on reel for crimp machines</i>							
Kontaktzuführung rechts <i>Contact feeding right hand side</i>	0,5 - 1,5 mm ²	20 - 16	2000	HN01 025 0001 (1)	HN02 025 0001 (1)		
	1,5 - 2,5 mm ²	16 - 14	2000	HN01 025 0010 (1)	HN02 025 0010 (1)		
Kontaktzuführung links <i>Contact feeding left hand side</i>	0,5 - 1,5 mm ²	20 - 16	2000	TN01 025 0001 (1)	TN02 025 0001 (1)		
	1,5 - 2,5 mm ²	16 - 14	2000	TN01 025 0010 (1)	TN02 025 0010 (1)		
Gedrehte Crimpkontakte / <i>Turned crimp contacts</i>							
Einzelkontakt <i>Single contact</i>	0,5 mm ²	20	100	VN01 025 0035 (1)C	VN02 025 0035 (1)C	VN01 025 0035 (2)C	VN02 025 0035 (2)C
	0,75 - 1,0 mm ²	18	100	VN01 025 0036 (1)C	VN02 025 0036 (1)C	VN01 025 0036 (2)C	VN02 025 0036 (2)C
	1,5 mm ²	16	100	VN01 025 0037 (1)C	VN02 025 0037 (1)C	VN01 025 0037 (2)C	VN02 025 0037 (2)C
	2,5 mm ²	14	100	VN01 025 0038 (1)C	VN02 025 0038 (1)C	VN01 025 0038 (2)C	VN02 025 0038 (2)C
	4,0 mm ²	12	100	VN01 025 0039 (1)C	VN02 025 0039 (1)C	VN01 025 0039 (2)C	VN02 025 0039 (2)C
Montageanleitung, Steckbild / <i>Assembly instruction, pin layout</i>							

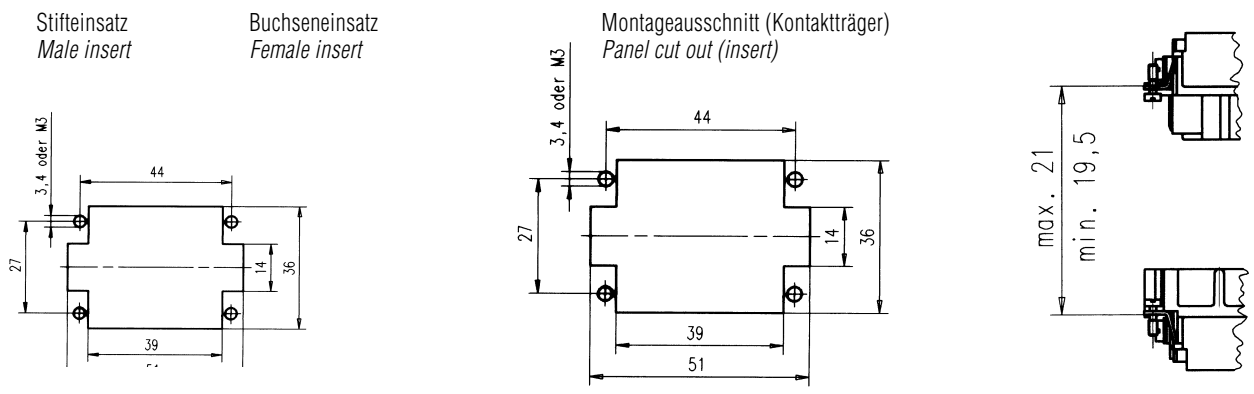

Derating Kurven / <i>Derating curves</i>		
<p>Gestanzte Kontakte Stamped contacts</p> <p>Strombelastbarkeit I (A) <i>Current carrying capacity I (A)</i></p> <p>Baulement Umgebungstemperatur T_U (°C) <i>Ambient temperature T_{amb} (°C)</i></p> <p>Kurve a: 1,5 mm² Leiterquerschnitt Curve a: 1,5 mm² wire gauge</p>	<p>Gedrehte Kontakte Turned contacts</p> <p>Strombelastbarkeit I (A) <i>Current carrying capacity I (A)</i></p> <p>Baulement Umgebungstemperatur T_U (°C) <i>Ambient temperature T_{amb} (°C)</i></p> <p>Kurve b: 2,5 mm² Leiterquerschnitt Curve b: 2,5 mm² wire gauge</p>	<p>Schraubanschluss Screw termination</p> <p>Strombelastbarkeit I (A) <i>Current carrying capacity I (A)</i></p> <p>Baulement Umgebungstemperatur T_U (°C) <i>Ambient temperature T_{amb} (°C)</i></p>

¹⁾ Erläuterung der Bestell-Nr. für die Kontakte siehe Seite 4
Explanation of the Part No. for contacts see page 4
Amphenol

Abisolierlängen siehe S. 208
Stripping length see p. 208

C 146 E

10 + 

Steckverbinder
Connectors

400 V~ Kontakteinsatz für gestanzte Kontakte /
Contact insert for stamped contacts



500 V~ Kontakteinsatz für Schraubanschluss und für gedrehte Kontakte /
Contact insert for screw termination and for turned contacts

16 / 22 A

Gehäuse siehe Seite 136–143

Housings see page 136–143

E

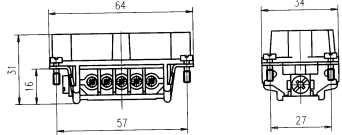
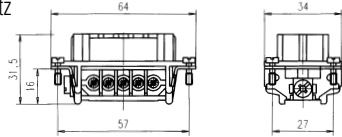
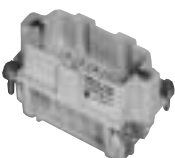
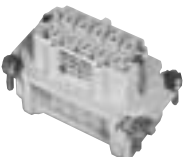
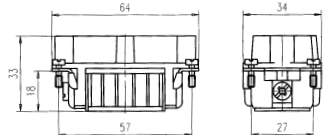
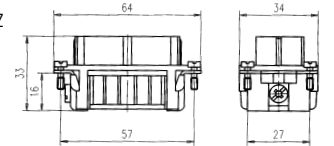
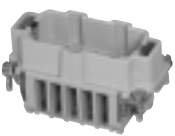
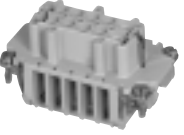
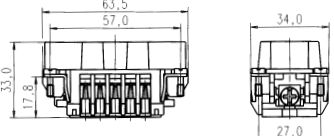
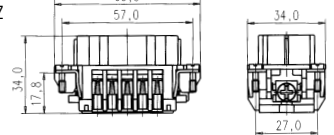
Bezeichnung - Abbildung Description - Figure	Maßzeichnung Drawing	Bestell Nr. / Part No.	
		Stifteinsatz / Male insert	Buchseinsatz / Female insert
Kontakteinsatz Schraubanschluss Contact insert screw termination  	Stifteinsatz Male insert  Buchseinsatz Female insert 	C146 10A010 002 1 C146 10A010 102 1 (mit Drahtschutz with wire protection)	C146 10B010 002 1 C146 10B010 102 1 (mit Drahtschutz with wire protection)
Kontakteinsatz für gestanzte Kontakte Contact insert for stamped contacts  	Stifteinsatz Male insert  Buchseinsatz Female insert 	C146 10A010 000 1	C146 10B010 000 1
Kontakteinsatz für gedrehte Kontakte Contact insert for turned contacts  	Stifteinsatz Male insert  Buchseinsatz Female insert 	C146 10A010 500 1	C146 10B010 500 1

C 146 E

10 + 

Crimpkontakte
Crimp contacts

Gestanzte Einzelkontakte
Stamped single contacts



Gedrehte Einzelkontakte
Turned single contacts



Gestanzte Bandkontakte für Crimpzangen
Stamped contacts on reel for hand crimping tools



200 / 100 Stück
200 / 100 pcs

Gestanzte Bandkontakte für Crimpmaschinen
Stamped contacts on reel for crimp machines



2000 Stück
(Zuführung links
oder rechts)
2000 pcs
(feeding left or
right hand side)

Lieferform Supplied as	für Leiter- querschnitt for wire gauge	AWG	Stück- zahl Pieces	Bestell Nr. ¹⁾ Stiftkontakt Male contact	Part No. ¹⁾ Buchsenkontakt Female contact	Bestell Nr. ¹⁾ Stiftkontakt Male contact	Part No. ¹⁾ Buchsenkontakt Female contact
Gestanzte Einzelkontakte / Stamped single contacts				versilbert / silver plating		vergoldet / gold plating	
	0,5 - 1,5 mm ²	20 - 16	100	VN01 025 0001 (101)	VN02 025 0001 (101)	VN01 025 0001 (102)	VN02 025 0001 (102)
	1,5 - 2,5 mm ²	16 - 14	100	VN01 025 0010 (101)	VN02 025 0010 (101)	VN01 025 0010 (102)	VN02 025 0010 (102)
Gestanzte Bandkontakte für Crimpzangen / Stamped Contacts on reel for hand crimp tools							
	0,5 - 1,5 mm ²	20 - 16	200	ZN01 025 0001 (1)	ZN02 025 0001 (1)	ZN01 025 0001 (2)	ZN02 025 0001 (2)
	1,5 - 2,5 mm ²	16 - 14	100	ZN01 025 0010 (1)	ZN02 025 0010 (1)	ZN01 025 0010 (2)	ZN02 025 0010 (2)
Gestanzte Bandkontakte für Crimpmaschinen / Stamped contacts on reel for crimp machines							
Kontaktzuführung rechts Contact feeding right hand side	0,5 - 1,5 mm ²	20 - 16	2000	HN01 025 0001 (1)	HN02 025 0001 (1)		
	1,5 - 2,5 mm ²	16 - 14	2000	HN01 025 0010 (1)	HN02 025 0010 (1)		
Kontaktzuführung links Contact feeding left hand side	0,5 - 1,5 mm ²	20 - 16	2000	TN01 025 0001 (1)	TN02 025 0001 (1)		
	1,5 - 2,5 mm ²	16 - 14	2000	TN01 025 0010 (1)	TN02 025 0010 (1)		
Gedrehte Crimpkontakte / Turned crimp contacts							
Einzelkontakt Single contact	0,5 mm ²	20	100	VN01 025 0035 (1)C	VN02 025 0035 (1)C	VN01 025 0035 (2)C	VN02 025 0035 (2)C
	0,75 - 1,0 mm ²	18	100	VN01 025 0036 (1)C	VN02 025 0036 (1)C	VN01 025 0036 (2)C	VN02 025 0036 (2)C
	1,5 mm ²	16	100	VN01 025 0037 (1)C	VN02 025 0037 (1)C	VN01 025 0037 (2)C	VN02 025 0037 (2)C
	2,5 mm ²	14	100	VN01 025 0038 (1)C	VN02 025 0038 (1)C	VN01 025 0038 (2)C	VN02 025 0038 (2)C
	4,0 mm ²	12	100	VN01 025 0039 (1)C	VN02 025 0039 (1)C	VN01 025 0039 (2)C	VN02 025 0039 (2)C
Montageanleitung, Steckbild / Assembly instruction, pin layout							

Stifteinsatz
Male insert

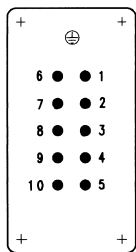

Buchseinsatz
Female insert

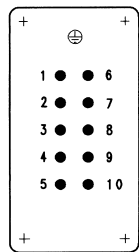

Montageausschnitt (Kontaktträger)
Panel cut out (insert)

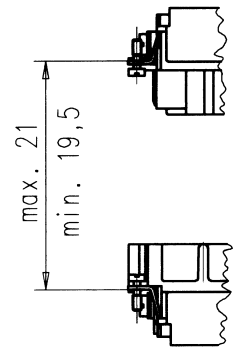
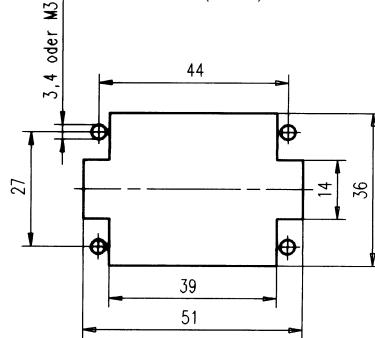

Derating Kurven / Derating curves

Gestanzte Kontakte
Stamped contacts

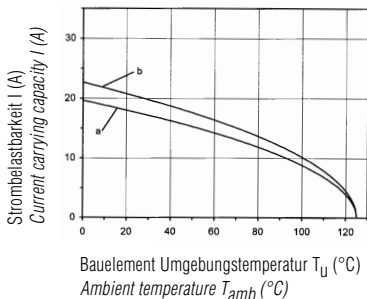

Kurve a: 1,5 mm² Leiterquerschnitt
Curve a: 1,5 mm² wire gauge

Gedrehte Kontakte
Turned contacts

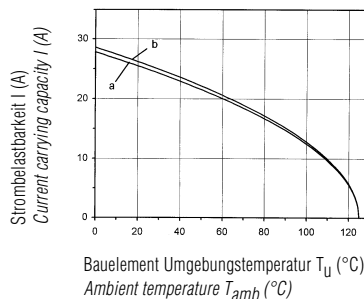

Kurve b: 2,5 mm² Leiterquerschnitt
Curve b: 2,5 mm² wire gauge

Schraubanschluss
Screw termination

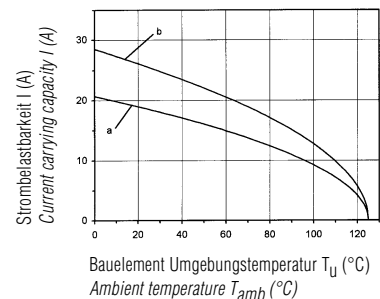

¹⁾ Erläuterung der Bestell-Nr. für die Kontakte siehe Seite 4
Explanation of the Part No. for contacts see page 4
Amphenol

Abisolierlängen siehe S. 208
Stripping length see p. 208

C 146 E

16 + 

Steckverbinder
Connectors

400 V~ Kontakteinsatz für gestanzte Kontakte /
Contact insert for stamped contacts

500 V~ Kontakteinsatz für Schraubanschluss und für gedrehte Kontakte /
Contact insert for screw termination and for turned contacts

16 / 22 A

Gehäuse siehe Seite 144–151

Housings see page 144–151

E

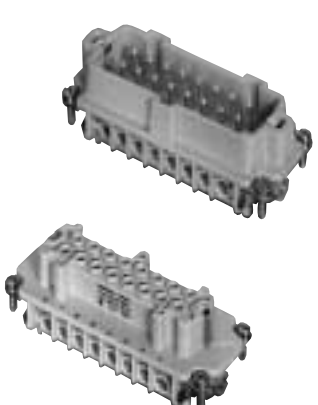
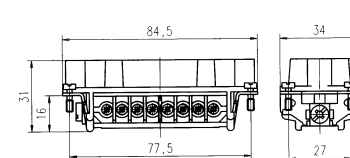
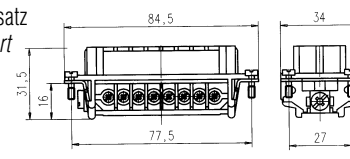
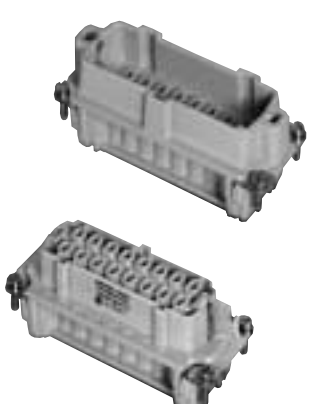
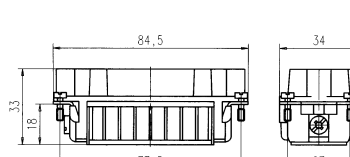
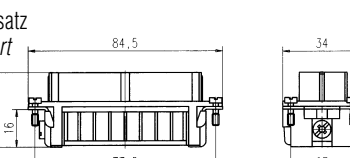
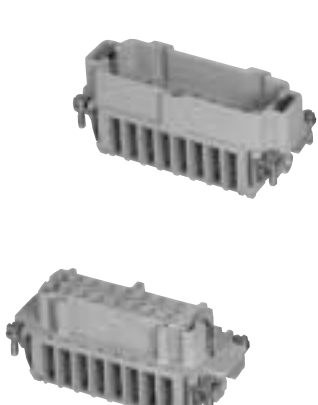
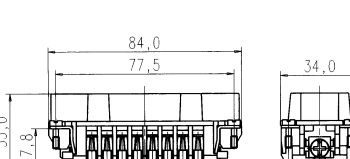
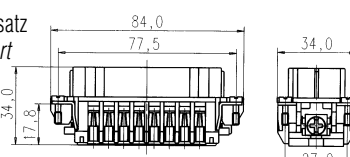
Bezeichnung - Abbildung Description - Figure	Maßzeichnung Drawing	Bestell Nr. / Part No.	
		Stifteinsatz / Male insert	Buchseinsatz / Female insert
Kontakteinsatz Schraubanschluss Contact insert screw termination 	Stifteinsatz Male insert  Buchseinsatz Female insert 	C146 10A016 002 1 C146 10A016 102 1 (mit Drahtschutz with wire protection)	C146 10B016 002 1 C146 10B016 102 1 (mit Drahtschutz with wire protection)
Kontakteinsatz für gestanzte Kontakte Contact insert for stamped contacts 	Stifteinsatz Male insert  Buchseinsatz Female insert 	C146 10A016 000 1	C146 10B016 000 1
Kontakteinsatz für gedrehte Kontakte Contact insert for turned contacts 	Stifteinsatz Male insert  Buchseinsatz Female insert 	C146 10A016 500 1	C146 10B016 500 1

C 146 E

16 + 

Crimpkontakte
Crimp contacts

Gestanzte Einzelkontakte
Stamped single contacts



Gedrehte Einzelkontakte
Turned single contacts



Gestanzte Bandkontakte für Crimpzangen
Stamped contacts on reel for hand crimping tools



200 / 100 Stück

200 / 100 pcs

Gestanzte Bandkontakte für Crimpmaschinen
Stamped contacts on reel for crimp machines



2000 Stück
(Zuführung links
oder rechts)

2000 pcs
(feeding left or
right hand side)

Lieferform Supplied as	für Leiter- querschnitt for wire gauge	AWG	Stück- zahl Pieces	Bestell Nr. ¹⁾ Stiftkontakt Male contact	Part No. ¹⁾ Buchsenkontakt Female contact	Bestell Nr. ¹⁾ Stiftkontakt Male contact	Part No. ¹⁾ Buchsenkontakt Female contact
Gestanzte Einzelkontakte / Stamped single contacts				versilbert / silver plating		vergoldet / gold plating	
	0,5 - 1,5 mm ²	20 - 16	100	VN01 025 0001 (101)	VN02 025 0001 (101)	VN01 025 0001 (102)	VN02 025 0001 (102)
	1,5 - 2,5 mm ²	16 - 14	100	VN01 025 0010 (101)	VN02 025 0010 (101)	VN01 025 0010 (102)	VN02 025 0010 (102)
Gestanzte Bandkontakte für Crimpzangen / Stamped Contacts on reel for hand crimp tools							
	0,5 - 1,5 mm ²	20 - 16	200	ZN01 025 0001 (1)	ZN02 025 0001 (1)	ZN01 025 0001 (2)	ZN02 025 0001 (2)
	1,5 - 2,5 mm ²	16 - 14	100	ZN01 025 0010 (1)	ZN02 025 0010 (1)	ZN01 025 0010 (2)	ZN02 025 0010 (2)
Gestanzte Bandkontakte für Crimpmaschinen / Stamped contacts on reel for crimp machines							
Kontaktzuführung rechts Contact feeding right hand side	0,5 - 1,5 mm ²	20 - 16	2000	HN01 025 0001 (1)	HN02 025 0001 (1)		
	1,5 - 2,5 mm ²	16 - 14	2000	HN01 025 0010 (1)	HN02 025 0010 (1)		
Kontaktzuführung links Contact feeding left hand side	0,5 - 1,5 mm ²	20 - 16	2000	TN01 025 0001 (1)	TN02 025 0001 (1)		
	1,5 - 2,5 mm ²	16 - 14	2000	TN01 025 0010 (1)	TN02 025 0010 (1)		
Gedrehte Crimpkontakte / Turned crimp contacts							
Einzelkontakt Single contact	0,5 mm ²	20	100	VN01 025 0035 (1)C	VN02 025 0035 (1)C	VN01 025 0035 (2)C	VN02 025 0035 (2)C
	0,75 - 1,0 mm ²	18	100	VN01 025 0036 (1)C	VN02 025 0036 (1)C	VN01 025 0036 (2)C	VN02 025 0036 (2)C
	1,5 mm ²	16	100	VN01 025 0037 (1)C	VN02 025 0037 (1)C	VN01 025 0037 (2)C	VN02 025 0037 (2)C
	2,5 mm ²	14	100	VN01 025 0038 (1)C	VN02 025 0038 (1)C	VN01 025 0038 (2)C	VN02 025 0038 (2)C
	4,0 mm ²	12	100	VN01 025 0039 (1)C	VN02 025 0039 (1)C	VN01 025 0039 (2)C	VN02 025 0039 (2)C
Montageanleitung, Steckbild / Assembly instruction, pin layout							

Stifteinsatz
Male insert

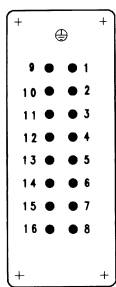

Buchseinsatz
Female insert

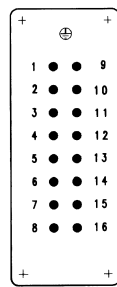

Montageausschnitt (Kontaktträger)
Panel cut out (insert)

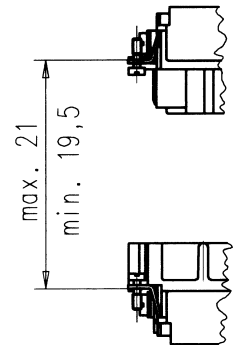
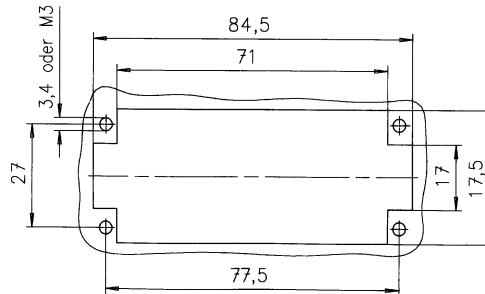

Derating Kurven / Derating curves

Gestanzte Kontakte
Stamped contacts

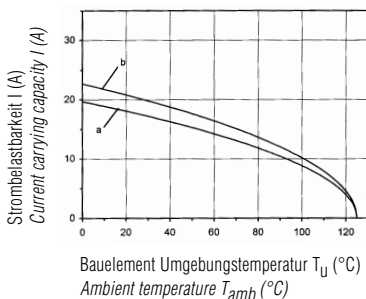

Kurve a: 1,5 mm² Leiterquerschnitt
Curve a: 1,5 mm² wire gauge

Gedrehte Kontakte
Turned contacts

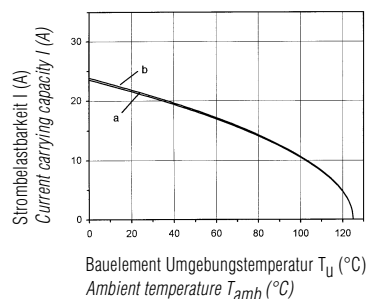

Kurve b: 2,5 mm² Leiterquerschnitt
Curve b: 2,5 mm² wire gauge

Schraubanschluss
Screw termination

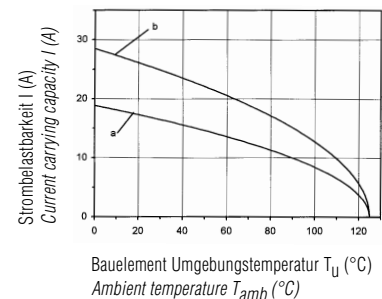

¹⁾ Erläuterung der Bestell-Nr. für die Kontakte siehe Seite 4
Explanation of the Part No. for contacts see page 4
Amphenol

Abisolierlängen siehe S. 208
Stripping length see p. 208

C 146 E

24 + 

Steckverbinder
Connectors

400 V~ Kontakteinsatz für gestanzte Kontakte /
Contact insert for stamped contacts

500 V~ Kontakteinsatz für Schraubanschluss und für gedrehte Kontakte /
Contact insert for screw termination and for turned contacts

16 / 22 A

Gehäuse siehe Seite 152–159

Housings see page 152–159

E

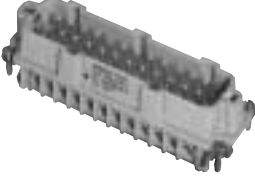
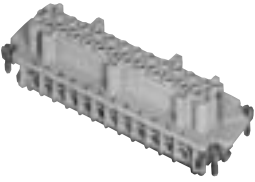
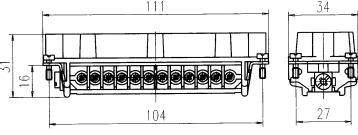
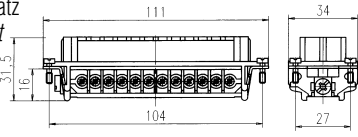
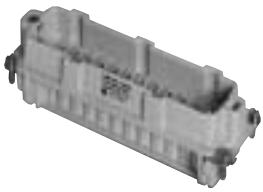
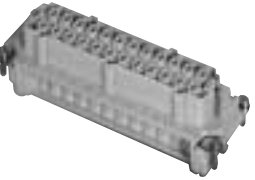
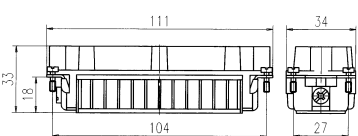
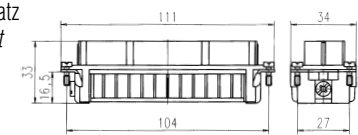
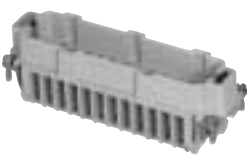
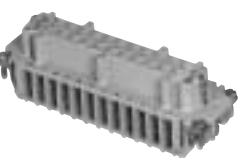
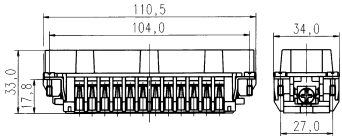
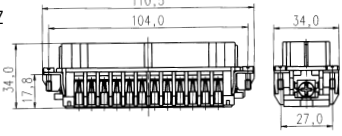
Bezeichnung - Abbildung Description - Figure	Maßzeichnung Drawing	Bestell Nr. / Part No.	
		Stifteinsatz / Male insert	Buchseinsatz / Female insert
Kontakteinsatz Schraubanschluss Contact insert screw termination  	Stifteinsatz Male insert  Buchseinsatz Female insert 	C146 10A024 002 1 C146 10A024 102 1 (mit Drahtschutz with wire protection)	C146 10B024 002 1 C146 10B024 102 1 (mit Drahtschutz with wire protection)
Kontakteinsatz für gestanzte Kontakte Contact insert for stamped contacts  	Stifteinsatz Male insert  Buchseinsatz Female insert 	C146 10A024 000 1	C146 10B024 000 1
Kontakteinsatz für gedrehte Kontakte Contact insert for turned contacts  	Stifteinsatz Male insert  Buchseinsatz Female insert 	C146 10A024 500 1	C146 10B024 500 1

C 146 E

24 +

Crimpkontakte
Crimp contacts

Gestanzte Einzelkontakte
Stamped single contacts



Gedrehte Einzelkontakte
Turned single contacts



Gestanzte Bandkontakte für Crimpzangen
Stamped contacts on reel for hand crimping tools



200 / 100 Stück
200 / 100 pcs

Gestanzte Bandkontakte für Crimpmaschinen
Stamped contacts on reel for crimp machines



2000 Stück
(Zuführung links oder rechts)
2000 pcs
(feeding left or right hand side)

Lieferform <i>Supplied as</i>	für Leiter- querschnitt <i>for wire gauge</i>	AWG	Stück- zahl <i>Pieces</i>	Bestell Nr. ¹⁾ Stiftkontakt <i>Male contact</i>	Part No. ¹⁾ Buchsenkontakt <i>Female contact</i>	Bestell Nr. ¹⁾ Stiftkontakt <i>Male contact</i>	Part No. ¹⁾ Buchsenkontakt <i>Female contact</i>
Gestanzte Einzelkontakte / <i>Stamped single contacts</i>				versilbert / <i>silver plating</i>		vergoldet / <i>gold plating</i>	
	0,5 - 1,5 mm ²	20 - 16	100	VN01 025 0001 (101)	VN02 025 0001 (101)	VN01 025 0001 (102)	VN02 025 0001 (102)
	1,5 - 2,5 mm ²	16- 14	100	VN01 025 0010 (101)	VN02 025 0010 (101)	VN01 025 0010 (102)	VN02 025 0010 (102)
Gestanzte Bandkontakte für Crimpzangen / <i>Stamped Contacts on reel for hand crimp tools</i>							
	0,5 - 1,5 mm ²	20 - 16	200	ZN01 025 0001 (1)	ZN02 025 0001 (1)	ZN01 025 0001 (2)	ZN02 025 0001 (2)
	1,5 - 2,5 mm ²	16 - 14	100	ZN01 025 0010 (1)	ZN02 025 0010 (1)	ZN01 025 0010 (2)	ZN02 025 0010 (2)
Gestanzte Bandkontakte für Crimpmaschinen / <i>Stamped contacts on reel for crimp machines</i>							
Kontaktzuführung rechts <i>Contact feeding right hand side</i>	0,5 - 1,5 mm ²	20 - 16	2000	HN01 025 0001 (1)	HN02 025 0001 (1)		
	1,5 - 2,5 mm ²	16 - 14	2000	HN01 025 0010 (1)	HN02 025 0010 (1)		
Kontaktzuführung links <i>Contact feeding left hand side</i>	0,5 - 1,5 mm ²	20 - 16	2000	TN01 025 0001 (1)	TN02 025 0001 (1)		
	1,5 - 2,5 mm ²	16 - 14	2000	TN01 025 0010 (1)	TN02 025 0010 (1)		
Gedrehte Crimpkontakte / <i>Turned crimp contacts</i>							
Einzelkontakt <i>Single contact</i>	0,5 mm ²	20	100	VN01 025 0035 (1)C	VN02 025 0035 (1)C	VN01 025 0035 (2)C	VN02 025 0035 (2)C
	0,75 - 1,0 mm ²	18	100	VN01 025 0036 (1)C	VN02 025 0036 (1)C	VN01 025 0036 (2)C	VN02 025 0036 (2)C
	1,5 mm ²	16	100	VN01 025 0037 (1)C	VN02 025 0037 (1)C	VN01 025 0037 (2)C	VN02 025 0037 (2)C
	2,5 mm ²	14	100	VN01 025 0038 (1)C	VN02 025 0038 (1)C	VN01 025 0038 (2)C	VN02 025 0038 (2)C
	4,0 mm ²	12	100	VN01 025 0039 (1)C	VN02 025 0039 (1)C	VN01 025 0039 (2)C	VN02 025 0039 (2)C
Montageanleitung, Steckbild / <i>Assembly instruction, pin layout</i>							

Stifteinsatz
Male insert

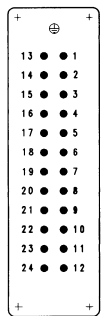

Buchseinsatz
Female insert

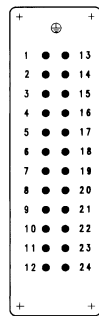

Montageausschnitt (Kontaktträger)
Panel cut out (insert)

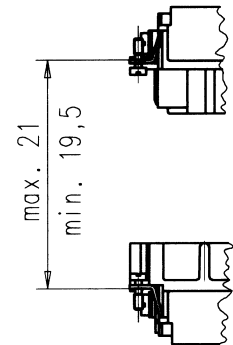
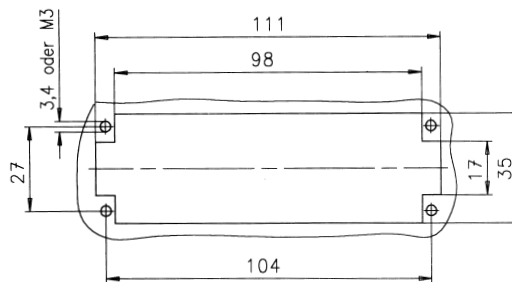

Derating Kurven / *Derating curves*

Gestanzte Kontakte
Stamped contacts

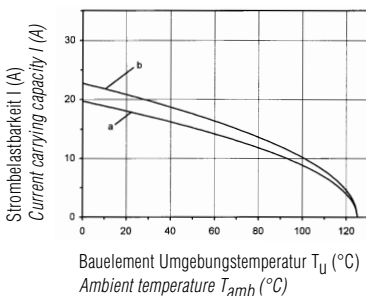

Kurve a: 1,5 mm² Leiterquerschnitt
Curve a: 1,5 mm² wire gauge

Gedrehte Kontakte
Turned contacts

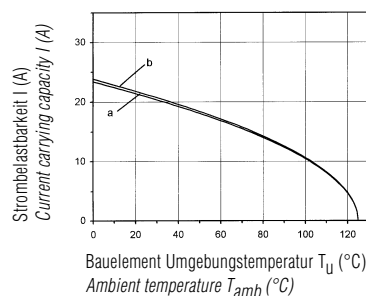

Kurve b: 2,5 mm² Leiterquerschnitt
Curve b: 2,5 mm² wire gauge

Schraubanschluss
Screw termination

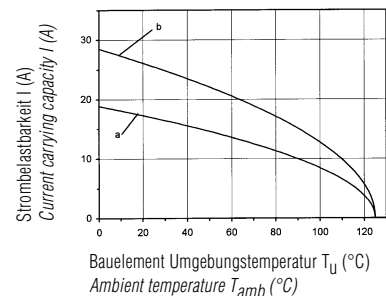

¹⁾ Erläuterung der Bestell-Nr. für die Kontakte siehe Seite 4
Explanation of the Part No. for contacts see page 4
Amphenol

Abisolierlängen siehe S. 208
Stripping length see p. 208

C 146 E

48 + 

Steckverbinder
Connectors

400 V~ Kontakteinsatz für gestanzte Kontakte /
Contact insert for stamped contacts

500 V~ Kontakteinsatz für Schraubanschluss und für gedrehte Kontakte /
Contact insert for screw termination and for turned contacts

16 / 22 A

Gehäuse siehe Seite 160–163

Housings see page 160–163

E

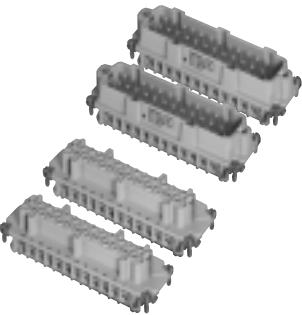
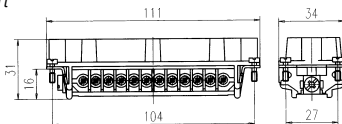
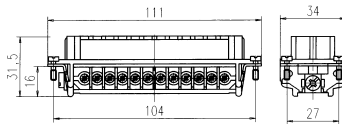
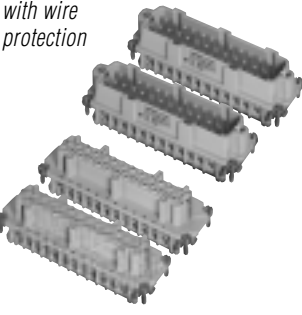
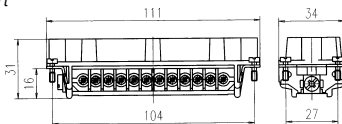
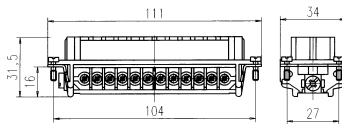
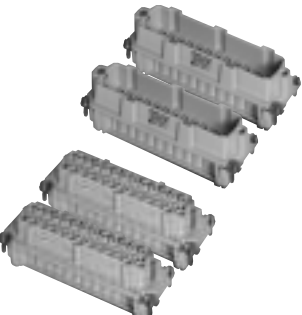
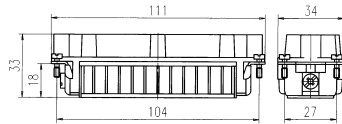
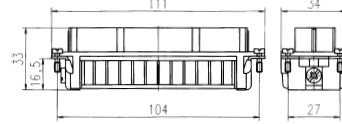
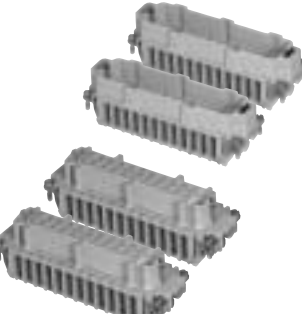
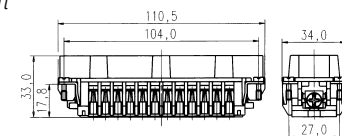
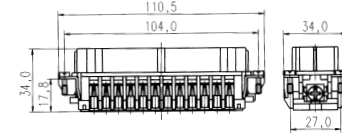
Bezeichnung - Abbildung Description - Figure	Maßzeichnung Drawing	Bestell Nr. / Part No.	
		Stifteinsatz / Male insert	Buchseinsatz / Female insert
Kontakteinsatz Schraubanschluss Contact insert screw termination 	Stifteinsatz Male insert  Buchseinsatz Female insert 	C146 10A024 002 1 + C146 10A024 004 1	C146 10B024 002 1 + C146 10B024 004 1
Kontakteinsatz Schraubanschluss mit Drahtschutz Contact insert screw termination with wire protection 	Stifteinsatz Male insert  Buchseinsatz Female insert 	C146 10A024 102 1 + C146 10A024 104 1	C146 10B024 102 1 + C146 10B024 104 1
Kontakteinsatz für gestanzte Kontakte Contact insert for stamped contacts 	Stifteinsatz Male insert  Buchseinsatz Female insert 	C146 10A024 000 1 + C146 10A024 005 1	C146 10B024 000 1 + C146 10B024 005 1
Kontakteinsatz für gedrehte Kontakte Contact insert for turned contacts 	Stifteinsatz Male insert  Buchseinsatz Female insert 	C146 10A024 500 1 + C146 10A024 505 1	C146 10B024 500 1 + C146 10B024 505 1

C 146 E

48 +

Crimpkontakte
Crimp contacts

Gestanzte Einzelkontakte
Stamped single contacts



Gedrehte Einzelkontakte
Turned single contacts



Gestanzte Bandkontakte für Crimpzangen
Stamped contacts on reel for hand crimping tools



200 / 100 Stück

200 / 100 pcs

Gestanzte Bandkontakte für Crimpmaschinen
Stamped contacts on reel for crimp machines



Lieferform Supplied as	für Leiter- querschnitt for wire gauge	AWG	Stück- zahl Pieces	Bestell Nr. ¹⁾ Stiftkontakt Male contact	Part No. ¹⁾ Buchsenkontakt Female contact	Bestell Nr. ¹⁾ Stiftkontakt Male contact	Part No. ¹⁾ Buchsenkontakt Female contact
Gestanzte Einzelkontakte / Stamped single contacts				versilbert / silver plating		vergoldet / gold plating	
	0,5 - 1,5 mm ²	20 - 16	100	VN01 025 0001 (101)	VN02 025 0001 (101)	VN01 025 0001 (102)	VN02 025 0001 (102)
	1,5 - 2,5 mm ²	16 - 14	100	VN01 025 0010 (101)	VN02 025 0010 (101)	VN01 025 0010 (102)	VN02 025 0010 (102)
Gestanzte Bandkontakte für Crimpzangen / Stamped Contacts on reel for hand crimp tools							
	0,5 - 1,5 mm ²	20 - 16	200	ZN01 025 0001 (1)	ZN02 025 0001 (1)	ZN01 025 0001 (2)	ZN02 025 0001 (2)
	1,5 - 2,5 mm ²	16 - 14	100	ZN01 025 0010 (1)	ZN02 025 0010 (1)	ZN01 025 0010 (2)	ZN02 025 0010 (2)
Gestanzte Bandkontakte für Crimpmaschinen / Stamped contacts on reel for crimp machines							
Kontaktzuführung rechts Contact feeding right hand side	0,5 - 1,5 mm ²	20 - 16	2000	HN01 025 0001 (1)	HN02 025 0001 (1)		
	1,5 - 2,5 mm ²	16 - 14	2000	HN01 025 0010 (1)	HN02 025 0010 (1)		
Kontaktzuführung links Contact feeding left hand side	0,5 - 1,5 mm ²	20 - 16	2000	TN01 025 0001 (1)	TN02 025 0001 (1)		
	1,5 - 2,5 mm ²	16 - 14	2000	TN01 025 0010 (1)	TN02 025 0010 (1)		
Gedrehte Crimpkontakte / Turned crimp contacts							
Einzelkontakt Single contact	0,5 mm ²	20	100	VN01 025 0035 (1)C	VN02 025 0035 (1)C	VN01 025 0035 (2)C	VN02 025 0035 (2)C
	0,75 - 1,0 mm ²	18	100	VN01 025 0036 (1)C	VN02 025 0036 (1)C	VN01 025 0036 (2)C	VN02 025 0036 (2)C
	1,5 mm ²	16	100	VN01 025 0037 (1)C	VN02 025 0037 (1)C	VN01 025 0037 (2)C	VN02 025 0037 (2)C
	2,5 mm ²	14	100	VN01 025 0038 (1)C	VN02 025 0038 (1)C	VN01 025 0038 (2)C	VN02 025 0038 (2)C
	4,0 mm ²	12	100	VN01 025 0039 (1)C	VN02 025 0039 (1)C	VN01 025 0039 (2)C	VN02 025 0039 (2)C
Montageanleitung, Steckbild / Assembly instruction, pin layout							

Stifteinsatz
Male insert

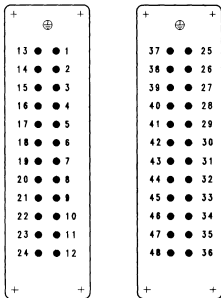

Buchseinsatz
Female insert

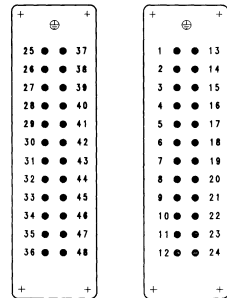

Montageausschnitt (Kontaktträger)
Panel cut out (insert)

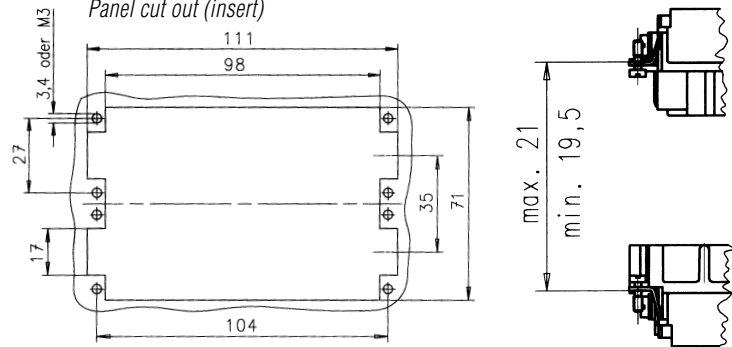

Derating Kurven / Derating curves

Gestanzte Kontakte
Stamped contacts

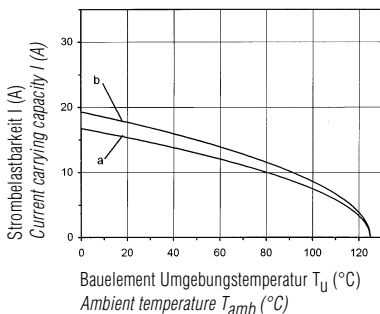

Kurve a: 1,5 mm² Leiterquerschnitt
Curve a: 1,5 mm² wire gauge

Gedrehte Kontakte
Turned contacts

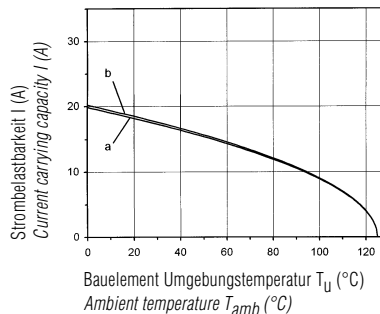

Kurve b: 2,5 mm² Leiterquerschnitt
Curve b: 2,5 mm² wire gauge

Schraubanschluss
Screw termination

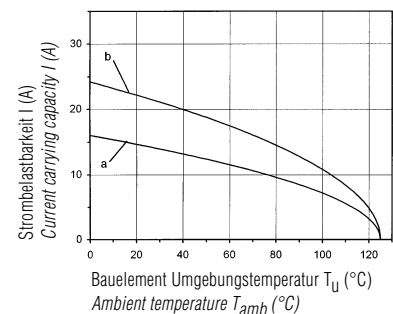

¹⁾ Erläuterung der Bestell-Nr. für die Kontakte siehe Seite 4
Explanation of the Part No. for contacts see page 4

Abisolierlängen siehe S. 208
Stripping length see p. 208

C 146 E

Werkzeuge ¹⁾ Tools ¹⁾

Bezeichnung / Description	für Leiterquerschnitt for wire gauge	Bestell Nr. / Part No.		Werkzeuge / Tools
		Kontaktaufnahme / Contact locator	Crimpbacken / Crimping dies	
Lösewerkzeug für gestanzte Kontakte Removal tool for stamped contacts	–	–	–	FG 0200 146 1
Crimpzange für gestanzte Einzelkontakte Crimping tool for stamped single contacts	0,5 - 1,5 mm ² 1,5 - 2,5 mm ²	TA 0004 146 000 1 TA 0005 146 000 3	TA 0000 163 TA 0000 141	TA 0000
4-Kerb Crimpzange für gedrehte Kontakte 4-indent crimping tool for turned contacts	0,5 - 4,0 mm ²	–	–	TB 0600 146 ²⁾



¹⁾ Weitere Informationen siehe Katalog „Werkzeuge“ / Further information see catalogue „Tools“

²⁾ Incl. Prüfstiftset + Kontaktaufnahme / incl. calibration pin set + contact locator

C 146 EE

EE



Hauptmerkmale		Main characteristics	
<ul style="list-style-type: none"> • Bemessungsspannung 500 V (600 V UL / CSA) • Bemessungsstrom 16 A • Anschlussstechnik: crimpen • Polzahl: 10, 18, 32, 46 		<ul style="list-style-type: none"> • Rated voltage 500 V (600 V UL / CSA) • Rated current 16 A • Termination technique: crimp • Number of contacts: 10, 18, 32, 46 	
Zulassungen / Approvals Prüfstelle / Testhouse		Kennwerte / Characteristics	Zulassungs-Nummer / Approval-No.
UL		600 V, 15 A	E 63093
CSA		600 V, 16 A	172062-1027396 (LR 48323-2)
<p>Zulassungen beziehen sich im allgemeinen auf repräsentative Ausführungen der Steckverbinderserie. Prüfumfang und Prüfvorschrift auf Anfrage.</p>		<p>In general approvals refer to representative versions of the connector series. Extent and specification of tests upon request.</p>	

C 146 EE

500 V~ 16 A







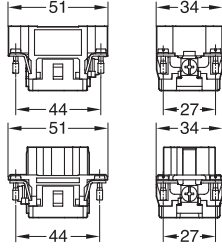

**Steckverbinder
Connectors**

**für gedrehte Kontakte
for turned contacts**

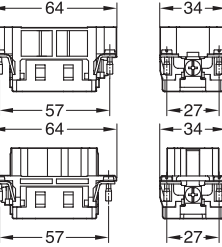
**Gehäuse siehe Seite 132–159
Housings see page 132–159**

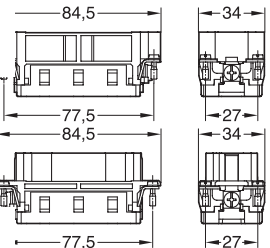
EE

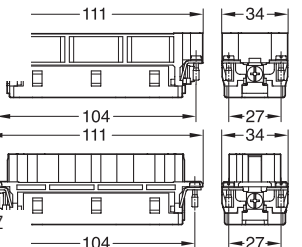
Bezeichnung Description	Maßzeichnung Drawing	Bestell Nr. / Part No.	
		Stifteinsatz / Male insert	Buchseinsatz / Female insert
Kontakteinsatz 10 + ⊕ Contact insert 10 + ⊕ 	Stifteinsatz Male insert  Buchseinsatz Female insert	C146 10A010 500 10	C146 10B010 500 10
Kontakteinsatz 18 + ⊕ Contact insert 18 + ⊕ 	Stifteinsatz Male insert  Buchseinsatz Female insert	C146 10A018 500 10	C146 10B018 500 10
Kontakteinsatz 32 + ⊕ Contact insert 32 + ⊕ 	Stifteinsatz Male insert  Buchseinsatz Female insert	C146 10A032 500 10	C146 10B032 500 10
Kontakteinsatz 46 + ⊕ Contact insert 46 + ⊕ 	Stifteinsatz Male insert  Buchseinsatz Female insert	C146 10A046 500 10	C146 10B046 500 10

Montageanleitung / Assembly instruction

Montageausschnitt (Kontaktträger)
Panel cut out (insert)

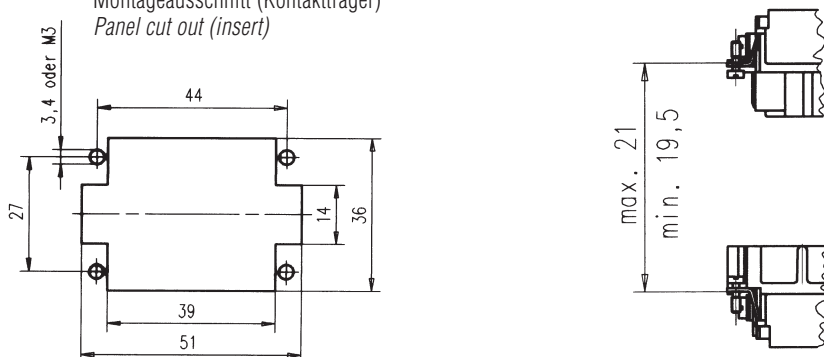

C 146 EE

Crimpkontakte Crimp contacts

Gedrehte 2,5 mm Kontakte
Turned 2,5 mm contacts



Steckbild, Ansicht Anschlussseite / Pin Layout, View from termination side

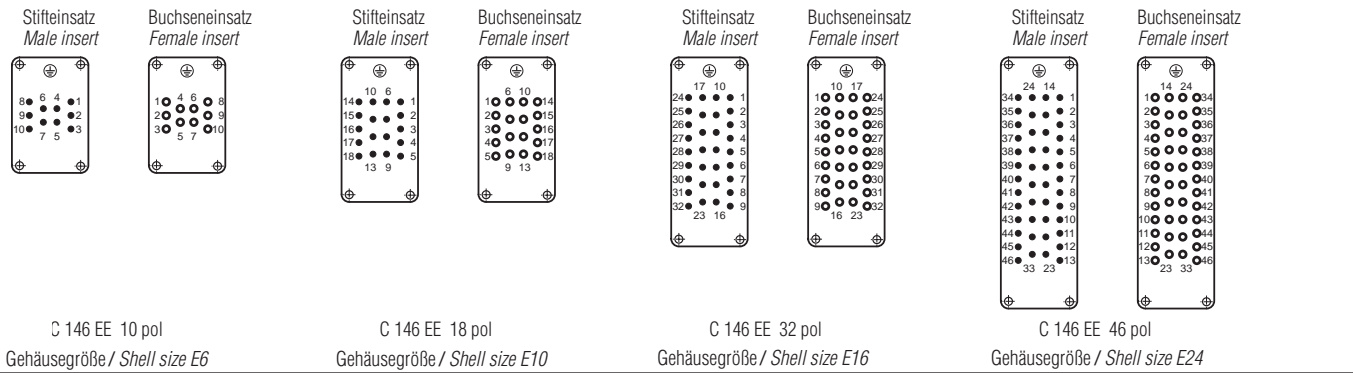

EE

Lieferform Supplied as	für Leiter- querschnitt for wire gauge	AWG	Stück- zahl Pieces	Bestell Nr. ¹⁾ Stiftkontakt Male contact	Part No. ¹⁾ Buchsenkontakt Female contact	Bestell Nr. ¹⁾ Stiftkontakt Male contact	Part No. ¹⁾ Buchsenkontakt Female contact
Gedrehte Crimpkontakte / Turned Crimp Contacts				versilbert / silver plating		vergoldet / gold plating	
Einzelkontakte Single contact	0,5 mm ²	20	100	VN01 025 0035 (1)C	VN02 025 0035 (1)C	VN01 025 0035 (2)C	VN02 025 0035 (2)C
	0,75 - 1,0 mm ²	18	100	VN01 025 0036 (1)C	VN02 025 0036 (1)C	VN01 025 0036 (2)C	VN02 025 0036 (2)C
	1,5 mm ²	16	100	VN01 025 0037 (1)C	VN02 025 0037 (1)C	VN01 025 0037 (2)C	VN02 025 0037 (2)C
	2,5 mm ²	14	100	VN01 025 0038 (1)C	VN02 025 0038 (1)C	VN01 025 0038 (2)C	VN02 025 0038 (2)C
	4,0 mm ²	12	100	VN01 025 0039 (1)C	VN02 025 0039 (1)C	VN01 025 0039 (2)C	VN02 025 0039 (2)C
Kontaktlösewerkzeug Contact removal tool				FG 0300 146 (7)			

Derating Kurven / Derating curves

C146 EE 10 pol

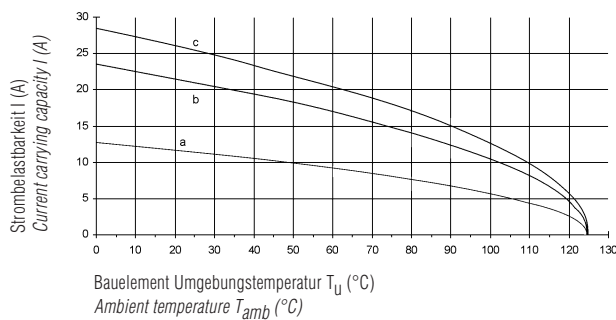

C146 EE 18 pol

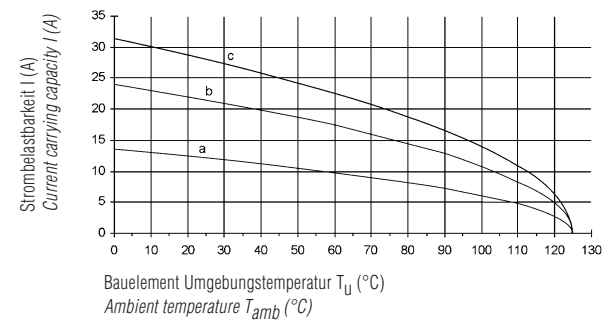

C146 EE 32 pol

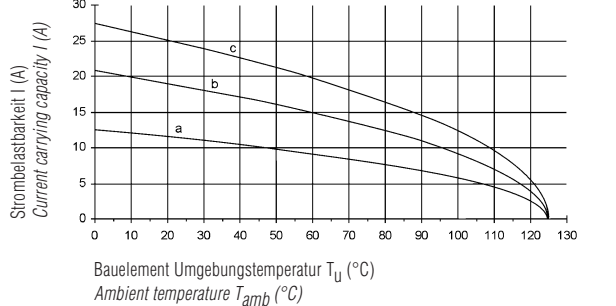

C146 EE 46 pol

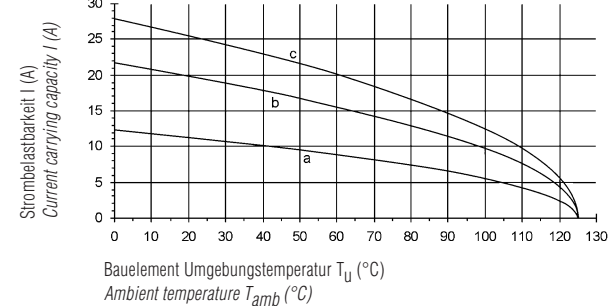

Kurve a: 0,5 mm² Anschlussquerschnitt
Curve a: 0,5 mm² wire gauge

Kurve b: 2,5 mm² Anschlussquerschnitt
Curve b: 2,5 mm² wire gauge

Kurve c: 4,0 mm² Anschlussquerschnitt
Curve c: 4,0 mm² wire gauge

Abisolierlängen siehe S. 208 / Stripping length see p. 208



Allgemeine Kennwerte	General Characteristics	Norm / Standard	Wert / Value			
Polzahl	Number of contacts		10 + ⊕	18 + ⊕	32 + ⊕	46 + ⊕
Anschluss technik	Termination technique		crimpen / crimp			
Anschlussquerschnitt	Wire gauge		0,5 mm ² - 4,0 mm ²			
Brennbarkeit	Flammability	UL 94	V-0			
Elektrische Kennwerte	Electrical Characteristics					
Bemessungsspannung	Rated voltage	IEC 60664-1	500 V (600 V UL / CSA)			
Verschmutzungsgrad	Pollution degree	IEC 60664-1	3			
Überspannungskategorie	Installation (overvoltage) category	IEC 60664-1	III			
Isolierstoffgruppe	Material group	IEC 60664-1	III b			
Bemessungs-Stoßspannung	Rated impulse withstand voltage	IEC 60664-1	6 kV			
Spannungsfestigkeit	Voltage proof	IEC 60512-2; Test 4 a	3 kV			
Strombelastbarkeit	Current carrying capacity	IEC 60512-3; Test 5 b	siehe Derating Kurven / see derating curves			
Bemessungsstrom T _U = 40 °C	Rated current T _{amb} = 40 °C		16 A			
Durchgangswiderstand	Contact resistance	IEC 60512-2; Test 2 a	≤ 5 m Ω			
Isolationswiderstand	Insulation resistance	IEC 60512-2; Test 3 a	≥ 10 ¹² Ω ¹⁾			
Luftstrecke	Clearance	IEC 60664-1	> 5,5 mm			
Kriechstrecke	Creepage	IEC 60664-1	> 10 mm			
Klimatische Kennwerte	Climatical Characteristics					
Prüfklasse	Climatic category	IEC 60068-1	40 / 100 / 21			
Obere Grenztemperatur	Upper temperature	IEC 60512-6; Test 11 i	+ 100 °C / 1000 h			
Untere Grenztemperatur	Lower temperature	IEC 60512-6; Test 11 i	- 40 °C / 16 h			
Mechanische Kennwerte	Mechanical Characteristics					
Mechanische Lebensdauer	Mechanical operation	IEC 60512-5; Test 9 a	≥ 500 Steckzyklen / mating cycles			
IP-Schutzart Stifteinsatz	IP-degree of protection pin insert	IEC 60529	ungesteckt/unmated IP00	gesteckt/mated IP20		
IP-Schutzart Buchseneinsatz	IP-degree of protection socket insert	IEC 60529	ungesteckt/unmated IP20	gesteckt/mated IP20		
Werkstoffe	Materials					
Kontakteinsatz	Insert		PC			
Kontakte	Contacts		CuZn (Messing / brass)			
Kontakt oberfläche	Contact plating		Ag (silber / silver)			
Farbe	Colour		grau / grey			

¹⁾ Bei Beanspruchung > 10¹⁰ Ω / Under operating conditions > 10¹⁰ Ω

C 146 E / D Anschlussverteiler / Terminal blocks

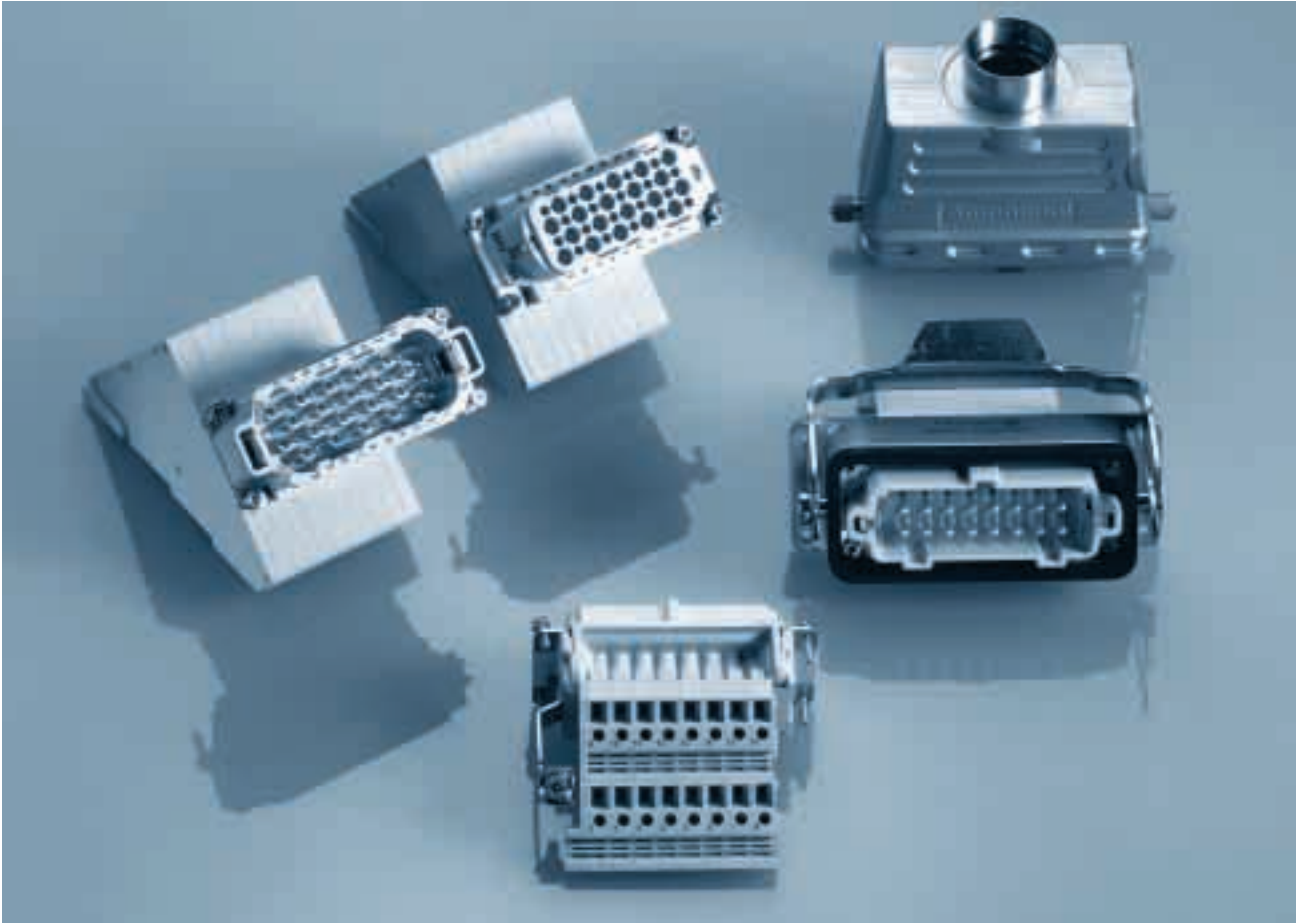
E/D



Hauptmerkmale		Main characteristics	
<ul style="list-style-type: none"> • Anschlussverteiler für Kontakteinsätze C 146 E 6 - 24 pol; C 146 D 40 - 64 pol • Weitere Technische Daten auf Anfrage 		<ul style="list-style-type: none"> • Terminal blocks for contacts inserts C 146 E 6 - 24 contacts; C 146 D 40 - 64 contacts • Further characteristics upon request 	
Zulassungen / Approvals Prüfstelle / Testhouse		Kennwerte / Characteristics	Zulassungs-Nummer / Approval-No.
C146 D		300 V, 5 A	48932
CSA			
C 146 E		300 V, 9 A	48932
CSA			
<p>Zulassungen beziehen sich im allgemeinen auf repräsentative Ausführungen der Steckverbinderserie. Prüfumfang und Prüfvorschrift auf Anfrage.</p>		<p><i>In general approvals refer to representative versions of the connector series. Extent and specification of tests upon request.</i></p>	

C 146
Anschlussverteiler
Terminal blocks

Kurzinformation
Brief information

Allgemeine Hinweise



Für den Einsatz an industriellen Anlagen sowie an steuer- und regeltechnischen Geräten wurden die Anschlussverteiler der Serie C 146 entwickelt. Die kompakte Bauweise dieser Kombination zwischen Steckverbinder und Reihenklemmen bringt Platzersparnis im Schaltschrank sowie reduzierte Verdrahtungs-, Kontroll- und Montagekosten. Die auf einer Schräge angeordneten Anschlussklemmen sind auch in mehrreihiger Anordnung sehr gut zugänglich, die Beschriftung der Klemmstelle ist durchnummeriert (aufgedruckte Zahlen). Zusätzlich kann sie durch Bezeichnungsschilder nochmals gekennzeichnet werden. Den Anschlussverteiler gibt es wahlweise mit rechts- oder linksseitigem Schutzleiteranschluss, um je nach Einsatzfall einen rechts-, bzw. linksseitigen Einbau in der Schaltschrankwand zu ermöglichen. Der Schutzleiteranschluss und die Klemme Nr. 1 befinden sich in beiden Einbaufällen an der Oberseite. Weitere technische Daten und Maße sowie die dazu passenden Gegenstecker und Gehäuse entnehmen Sie bitte den nachfolgenden Seiten.

The terminal blocks of the series C 146 were designed for application in industrial facilities and also for power and control devices. The compact construction of this combination of connector and busbar will allow space savings behind the panel as well as termination-, inspection- and assembly cost. Due to the tapered arrangement of the termination clamps access is easy even on multi-row construction, the identification of the stations is numeric (printed). Additional identification is possible with six digit numeric tags. The terminal blocks are available with right- or leftside PE termination to be mounted right or left on the panel wall depending on the individual application. In both applications the PE termination and clamp No. 1 are on the upper side. On the following pages of the catalogue you will find information on further technical data and dimensions as well as on the housings and connectors to be mated.

General information

Montageanleitung, Steckbild / Assembly instruction, pin layout

Stift-/ Buchseneinsatz
linke Ausführung

Male/Female insert
left version

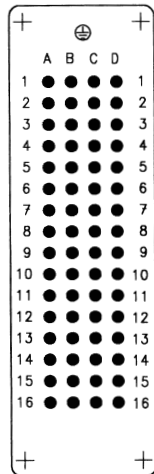
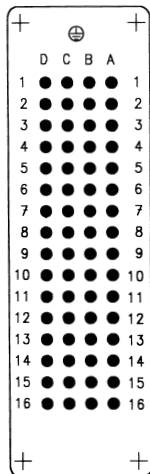

Kontakt Nr. 1
Contact No. 1

Stift-/ Buchseneinsatz
rechte Ausführung

Male/Female insert
right version

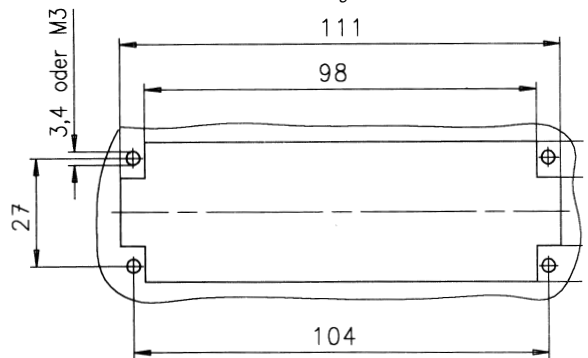

C 146 E AV
Anschlussverteiler
Terminal blocks

400 V~ 16 A

Steckverbinder
Connectors

Gehäuse siehe Seite 132-159
Housings see page 132-159

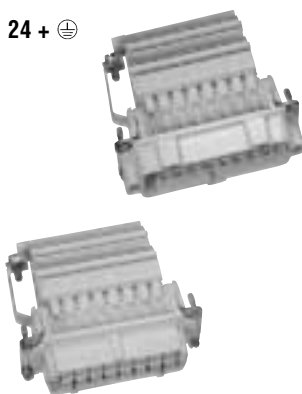
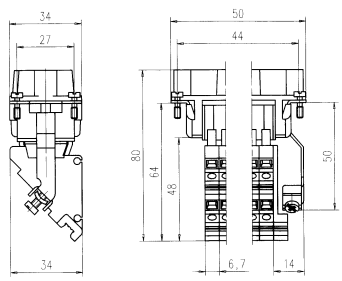
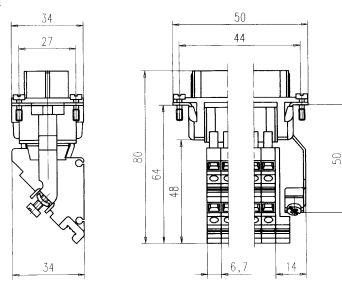
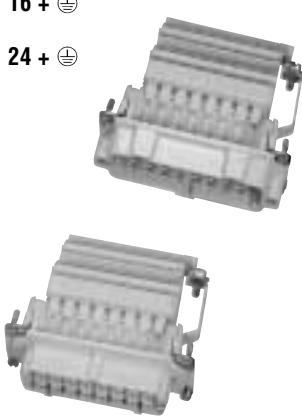
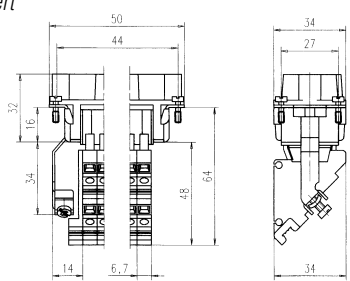
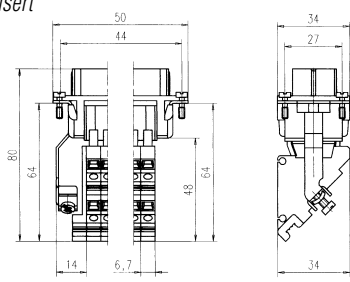
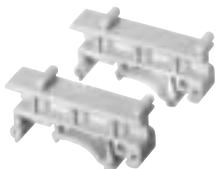
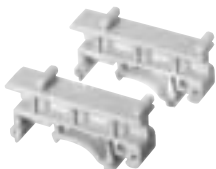
Bezeichnung - Abbildung Description - Figure	Maßzeichnung 6 + ⊕ ¹⁾ Drawing 6 + ⊕ ¹⁾	Bestell Nr. / Part No.	
		Stifteinsatz / Male insert	Buchseinsatz / Female insert
Kontakteinsatz Schutzkontakt - links Contact insert protection earth - left 6 + ⊕ 10 + ⊕ 16 + ⊕ 24 + ⊕ 	Stifteinsatz Male insert  Buchseinsatz Female insert 	C146 12A006 102 1 C146 12A010 102 1 C146 12A016 102 1 C146 12A024 102 1	C146 12B006 102 1 C146 12B010 102 1 C146 12B016 102 1 C146 12B024 102 1
Kontakteinsatz Schutzkontakt - rechts Contact insert protection earth - right 6 + ⊕ 10 + ⊕ 16 + ⊕ 24 + ⊕ 	Stifteinsatz Male insert  Buchseinsatz Female insert 	C146 12A006 152 1 C146 12A010 152 1 C146 12A016 152 1 C146 12A024 152 1	C146 12B006 152 1 C146 12B010 152 1 C146 12B016 152 1 C146 12B024 152 1
Zubehör / Accessories			
Tragschienenadapter Fixing element 			C146 N21 040 E1 X (10 Stk./10 pcs)

¹⁾ Weitere Maße der Steckverbinder siehe Serie C146 E, Seite 34-40 / Further dimensions for the connectors see series C146 E, page 34-40.

C 146 D AV
Anschlussverteiler
Terminal blocks

250 V~ 10 A

Steckverbinder
Connectors

Gehäuse siehe Seite 144-159
Housings see page 144-159

E/D

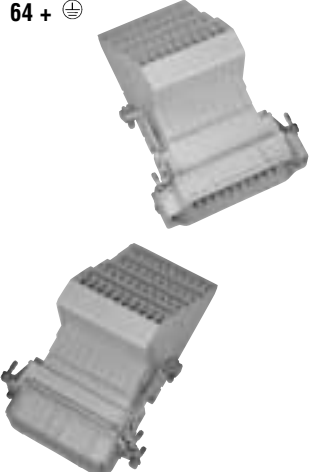
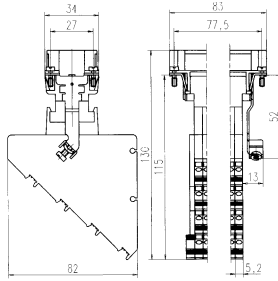
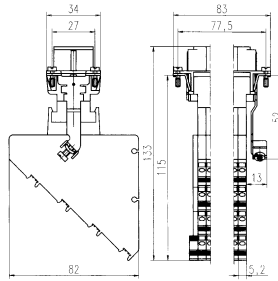
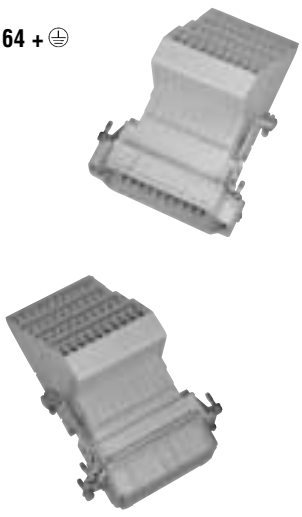
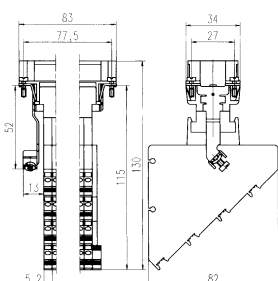
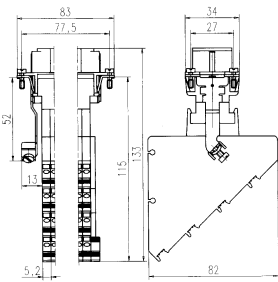
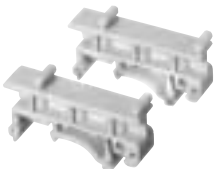
Bezeichnung - Abbildung Description - Figure	Maßzeichnung 40 + ⊕ ¹⁾ Drawing 40 + ⊕ ¹⁾	Bestell Nr. / Part No.	
		Stifteinsatz / Male insert	Buchseinsatz / Female insert
Kontakteinsatz Schutzkontakt - links Contact insert protection earth - left 40 + ⊕ 64 + ⊕ 	Stifteinsatz Male insert  Buchseinsatz Female insert 	C146 12A040 102 2 C146 12A064 102 2	C146 12B040 102 2 C146 12B064 102 2
Kontakteinsatz Schutzkontakt - rechts Contact insert protection earth - right 40 + ⊕ 64 + ⊕ 	Stifteinsatz Male insert  Buchseinsatz Female insert 	C146 12A040 152 2 C146 12A064 152 2	C146 12B040 152 2 C146 12B064 152 2
Zubehör / Accessories			
Tragschienenadapter Fixing element 		C146 N21 040 E1 X (10 Stk./10 pcs)	

¹⁾ Weitere Maße der Steckverbinder siehe Serie C146 D, Seite 16 und 20. / Further dimensions for the connectors see series C146 D, page 16 and 20.

C 146 E/FE/KO

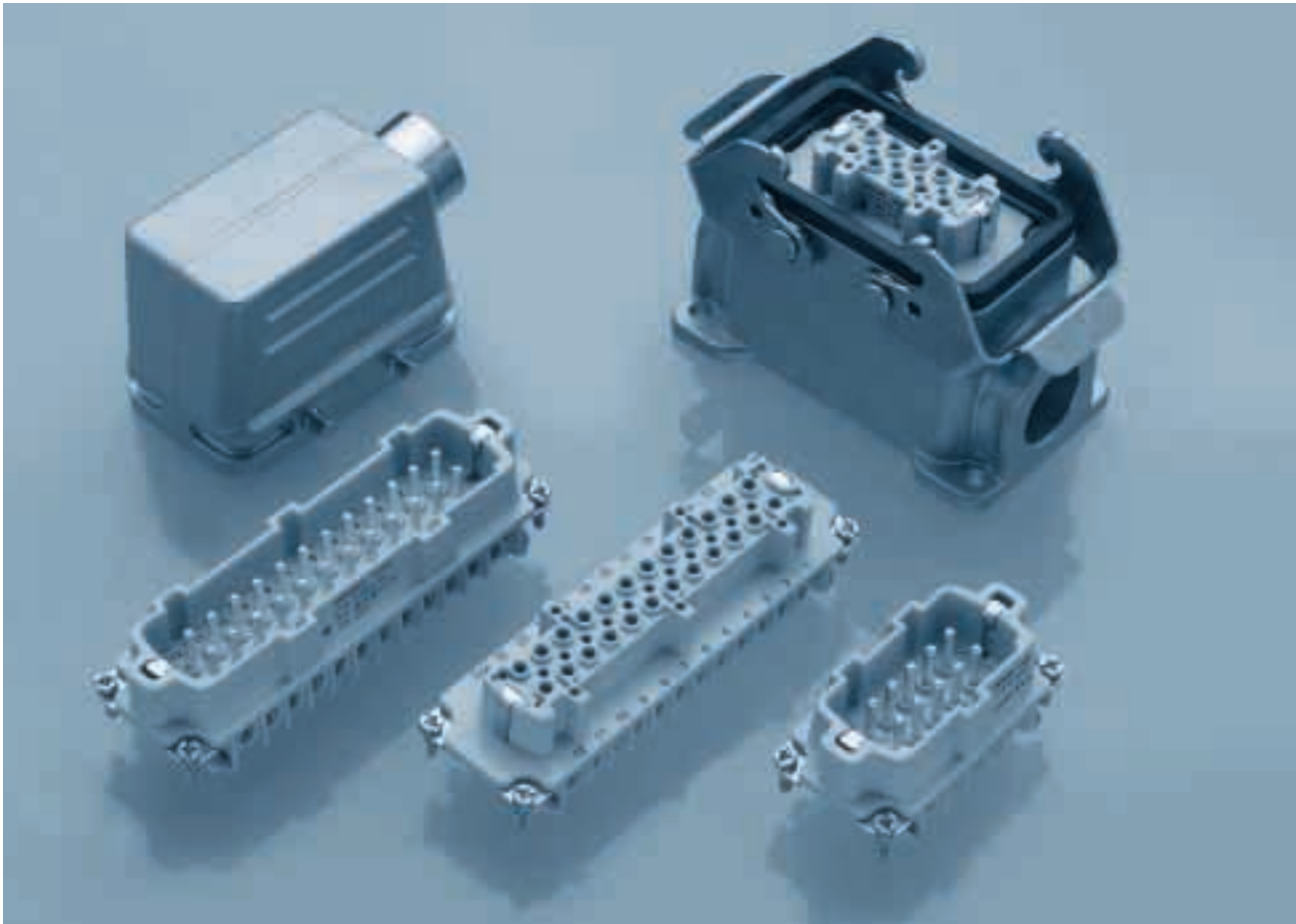

E/FE/KO

Hauptmerkmale

- Bemessungsspannung 400 V
- Material Kontakte: Eisen-Konstantan
- Bemessungsstrom 10 A
- Polzahl: 6, 10, 16, 24

Main characteristics

- *Rated voltage 400 V*
- *Material contacts: iron-constantan*
- *Rated current 10 A*
- *Number of contacts: 6, 10, 16, 24*

Kurzinformation
Brief information

Bezeichnung - Abbildung

Description - Figure

Steckverbinder mit Eisen-(FE) und Konstantan(KO)-Kontaktelementen

finden vornehmlich in der Steuer- und Regeltechnik ihren Einsatz, und zwar dort, wo es gilt, zwischen Eisen- bzw. Konstantan-Leitungen „Schnittstellen“ zu schaffen. FE/KO-Kabel werden üblicherweise als Verbindungsglied zwischen Thermoelement und Regelgerät eingesetzt.

Z. B. : Messen und Regeln der Temperatur in Kunststoff-Spritzformen Spritzformen (Heißkanal-Anspritzung) mittels Thermofühler und elektronischem Regelgerät.

Durch das Einbringen von FE/KO-Steckverbindern in die „Thermofühlerleitung“ werden die Messergebnisse verfeinert, d. h. die Regelungenauigkeit wird stark reduziert.

Soll-Wert-Abweichung bei verschiedenen Kontaktwerkstoff-Paarungen

Kontaktwerkstoffe Soll.-Temp.	ohne Thermo-Kontakte		mit Thermo-Kontakte	
	MS/FE	MS/KO	FE/FE	KO/KO
100 °C	+ 4 %	- 16 %	- 4 %	- 2 %
200 °C	+ 2,5 %	- 8 %	- 3 %	- 1,5 %
300 °C	+ 1,3 %	- 12,7 %	- 1,3 %	0 %
400 °C	+ 1,5 %	- 4,5 %	- 1,0 %	0 %

Die Werte sind auf eine Umgebungstemperatur von 100 °C bezogen.

Die Ursache der Sollwert-Abweichung (Übertragungsverlust) bei Steckverbindern mit Messingkontakten liegt in der selbsterzeugenden Thermospannung (hervorgerufen durch den Wechsel von FE-Draht zu Messing-Kontaktelement) bzw. durch die Temperaturschwankungen an den Kontaktelementen.

Einsatz von Thermo-Werkstoffen

in Abhängigkeit der Messtemperatur

Temperaturbereich	Temperaturbereich
< 150 °C	beliebig / Widerstandsmessung
150 °C - 450 °C	FE-KO (Eisen/Konstantan)
450 °C - ca. 1000 °C	Ni/Cr - Ni (Nickel/Cromleg./Nickel)

Faktoren, die das Messergebnis zusätzlich beeinflussen

- schwankende Umgebungstemperaturen (am Steckverbinder)

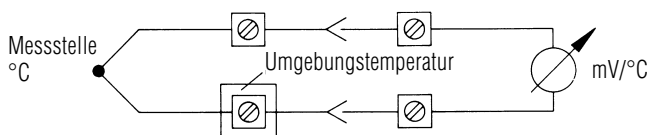

Connectors with iron (FE) and constantan (CO) contacts

are basically used in measuring and control circuits to serve as interface between FE/CO thermocouples and control unit, i. e. temperature control of moulds in injection moulding machines.

Through the use of FE/CO connectors in the thermocouple circuit the measuring results are more accurate, thus the tolerance of the temperature control is much narrower.

Amphenol's Industrial Connectors with iron (FE) and Constantan (CO) contacts are used to connect FE/CO thermocouples with electronic signal amplifiers in measuring and control circuits, i. e. for temperature control of moulding machines.

Errors with various combinations

Contact Material Nominal Temp.	without Thermo Contacts		with Thermo Contacts	
	MS/FE	MS/KO	FE/FE	KO/KO
100 °C	+ 4 %	- 16 %	- 4 %	- 2 %
200 °C	+ 2,5 %	- 8 %	- 3 %	- 1,5 %
300 °C	+ 1,3 %	- 12,7 %	- 1,3 %	0 %
400 °C	+ 1,5 %	- 4,5 %	- 1,0 %	0 %

The connection of unlike metals (FE/Brass and CO/Brass) generate thermoelectric voltage errors in the measuring circuit caused by the flow from iron wire to the brass contact or by temperature changes at the contact elements.

By using FE/CO contacts respectively these deviations will be minimized.

Material / Temperature Range

Temperatur range	Material/measurement procedure
< 150 °C	any/Resistance measurement
150 °C - 450 °C	FE-CO (iron/Constantan)
450 °C - approx. 1000 °C	Ni/Cr-Ni (Nickel/Chrome/Nickel)

Temperature changes cause errors:

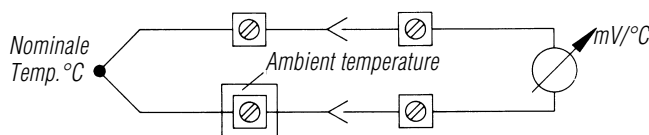

Allgemeine Kennwerte	General Characteristics	Norm / Standard	Wert / Value			
Polzahl	<i>Number of contacts</i>		6 + ⊕	10 + ⊕	16 + ⊕	24 + ⊕
Anschlussstechnik	<i>Termination technique</i>		schrauben / <i>screw</i>			
Anschlussquerschnitt	<i>Wire gauge</i>		0,25 mm ² - 2,5 mm ²			
Brennbarkeit	<i>Flammability</i>	UL 94	V-0			
Elektrische Kennwerte	Electrical Characteristics					
Bemessungsspannung	<i>Rated voltage</i>	IEC 60664-1	400 V			
Verschmutzungsgrad	<i>Pollution degree</i>	IEC 60664-1	3			
Überspannungskategorie	<i>Installation (overvoltage) category</i>	IEC 60664-1	III			
Isolierstoffgruppe	<i>Material group</i>	IEC 60664-1	III b			
Bemessungs-Stoßspannung	<i>Rated impulse withstand voltage</i>	IEC 60664-1	6,0 kV			
Spannungsfestigkeit	<i>Voltage proof</i>	IEC 60512-2; Test 4 a	2,8 kV			
Bemessungsstrom T _U = 40 °C	<i>Rated current T_{amb} = 40 °C</i>	IEC 60512-3	10 A			
Durchgangswiderstand	<i>Contact resistance</i>	IEC 60512-2; Test 2 a	≤ 10 m Ω			
Isolationswiderstand	<i>Insulation resistance</i>	IEC 60512-2; Test 3 a	≥ 10 ¹² Ω ¹⁾			
Klimatische Kennwerte	Climatical Characteristics					
Prüfklasse	<i>Climatic category</i>	IEC 60068-1	40 / 100 / 21			
Obere Grenztemperatur	<i>Upper temperature</i>	IEC 60512-6; Test 11 i	+ 100 °C / 1000 h			
Untere Grenztemperatur	<i>Lower temperature</i>	IEC 60512-6; Test 11 i	- 40 °C / 16 h			
Mechanische Kennwerte	Mechanical Characteristics					
Steck- und Ziehkraft	<i>Insertion and withdrawal forces</i>	IEC 60512-7; Test 13 b	< 40 N	< 70 N	< 95 N	< 165 N
²⁾ IP-Schutzart Stifteinsatz	<i>IP-degree of protection pin insert</i>	IEC 60529	ungesteckt/ <i>unmated</i> IP00		gesteckt/ <i>mated</i> IP20	
²⁾ IP-Schutzart Buchseneinsatz	<i>IP-degree of protection socket insert</i>	IEC 60529	ungesteckt/ <i>unmated</i> IP20		gesteckt/ <i>mated</i> IP20	
Gewicht Stifteinsatz	<i>Weight pin insert</i>		45 g	60 g	78 g	105 g
Gewicht Buchseneinsatz	<i>Weight socket insert</i>		45 g	60 g	78 g	105 g
Mechanische Lebensdauer	<i>Mechanical operation</i>	IEC 60512-5; Test 9 a	≥ 100 Steckzyklen / <i>mating cycles</i>			
Werkstoffe	Materials					
Material Kontakteinsatz	<i>Material insert</i>		PA, GV (Polyamid)			
Material Kontakte	<i>Material contacts</i>		Eisen / <i>iron</i> ; gal cd 4 Konstantan = roh; <i>constantan</i> = without plating			
Farbton	<i>Colour</i>		grau / <i>grey</i> RAL 7032			

¹⁾ Bei Beanspruchung >10¹⁰ Ω / *Under operating conditions > 10¹⁰ Ω*

²⁾ IP-Schutzart im Anschlussbereich der Schraubausführung IP 10 / *IP-degree of protection on termination side of screw version IP 10*









C 146 E FE-KO
6 -24 + 

Steckverbinder mit Eisen-Konstantan-Kontakten
Connectors with iron-constantan contacts

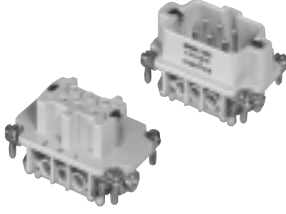
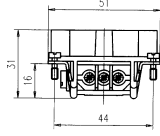
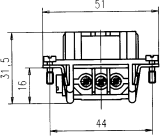
Steckverbinder
Connectors

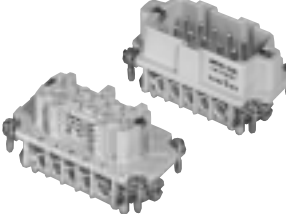
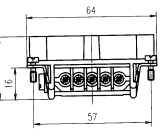
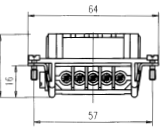
Gehäuse siehe Seite 132–159
Housings see page 132–159

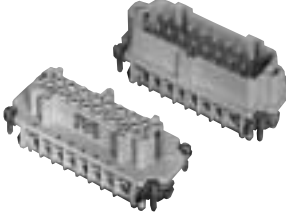
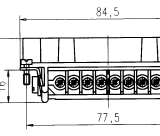
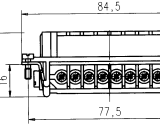
E/FE/KO

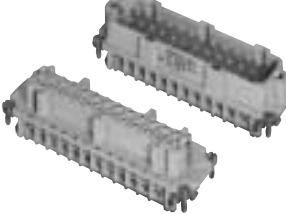
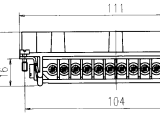
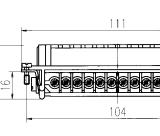
Bezeichnung - Abbildung Description - Figure	Maßzeichnung Drawing	Bestell Nr. / Part No.	
		Stifteinsatz / Male insert	Buchseinsatz / Female insert
Kontakteinsatz 6 +  ¹⁾ Contact insert 6 +  ¹⁾ 	Stifteinsatz Male insert  Buchseinsatz Female insert 	C146 10A006 810 1	C146 10B006 810 1
Kontakteinsatz 10 +  ¹⁾ Contact insert 10 +  ¹⁾ 	Stifteinsatz Male insert  Buchseinsatz Female insert 	C146 10A010 810 1	C146 10B010 810 1
Kontakteinsatz 16 +  ¹⁾ Contact insert 16 +  ¹⁾ 	Stifteinsatz Male insert  Buchseinsatz Female insert 	C146 10A016 810 1	C146 10B016 810 1
Kontakteinsatz 24 +  ¹⁾ Contact insert 24 +  ¹⁾ 	Stifteinsatz Male insert  Buchseinsatz Female insert 	C146 10A024 810 1	C146 10B024 810 1

Steckbild / pin layout

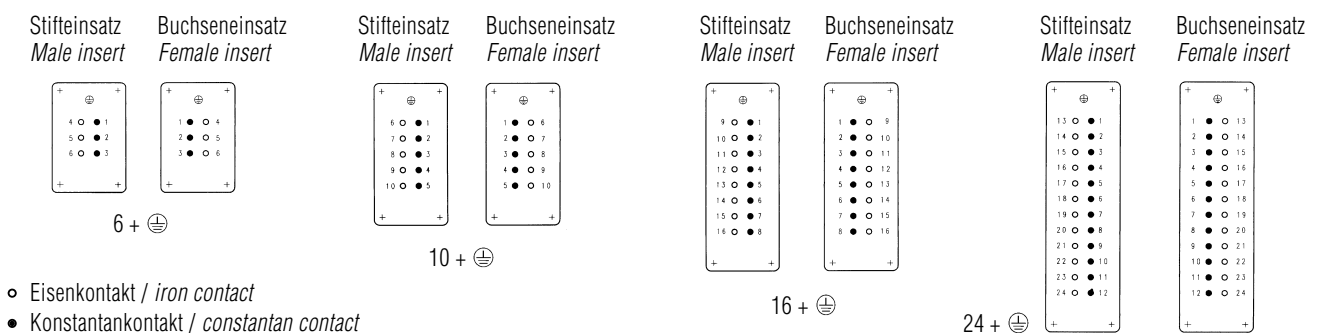



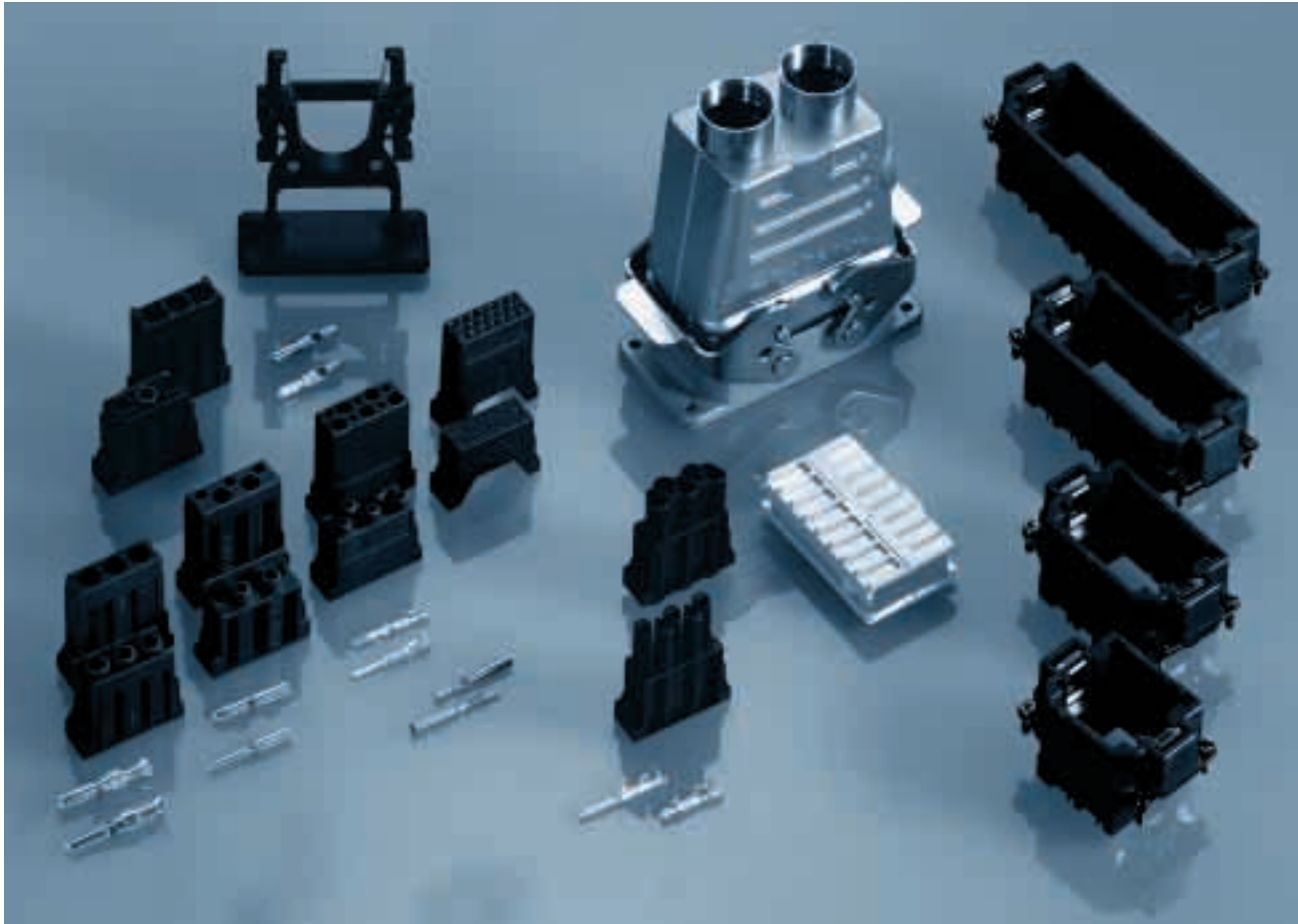

¹⁾ mit Drahtschutz / with wire protection

C 146 M



M

Hauptmerkmale		Main characteristics	
<ul style="list-style-type: none"> • Modular aufgebauter Steckverbinder • Bemessungsspannung 63 - 1000 V • Bemessungsstrom 5 A ... 70 A • Anschlussart: crimpen • Polzahl: 3 - 280 		<ul style="list-style-type: none"> • Modular connector • Rated voltage 63 - 1000 V • Rated current 5 A ... 70 A • Termination: crimp • Number of contacts: 3 - 280 	
Zulassungen / Approvals		Zulassungs-Nummer / Approval-No.	
Prüfstelle / Testhouse			
VDE			56 79 ÜG
BGZ		Kennwerte siehe Bemessungsspannung und Bemessungsstrom S. 61	VBG 70
SEV			
UL		Characteristics see rated voltage and rated current page 61	E 63093
CSA			48932
Zulassungen beziehen sich im allgemeinen auf repräsentative Ausführungen der Steckverbinderserie. Prüfumfang und Prüfvorschrift auf Anfrage.		In general approvals refer to representative versions of the connector series. Extent and specification of tests upon request.	

C 146 M

Kurzinformation Brief information

Allgemeine Hinweise



General information

- Module ohne Crimpkontakte, Crimpwerkzeuge siehe separater Katalog „Werkzeuge“.
- Kontakte müssen separat bestellt werden, Verarbeitungs- und Montagehinweise siehe Katalog „Werkzeuge“.
- Für die Einsätze der Serie C 146 M werden die hohen Gehäusebauformen empfohlen.
- Steckverbinder der Serie C 146 M dürfen unter Spannung, jedoch nicht unter Strom betätigt werden. Werden die Steckverbinder unter Last gesteckt und getrennt, ist der Strom auf 10 % des Bemessungsstroms zu begrenzen.
- Leere Modulplätze sind durch Blindmodule aufzufüllen.
- Drehmoment für PE-Anschluss 1,8 Nm
- *Modules inserts without crimp contacts, crimping tools see separate catalogue „Tools“.*
- *Contacts must be ordered separately, processing instructions see catalogue „Tools“.*
- *We recommend using the high profile housings / hoods for the C146 M inserts.*
- *Connectors series C 146 M may be engaged or disengaged when live but without electrical load.*
- *If these connectors are mated or unmated under load, the load shall be reduced to 10 % of rated current.*
- *Empty modul spaces have to be filled with blind modules.*
- *Torque for PE connection 1,8 Nm*

Systemvorteile

Advantages of the system

- Viele Kombinationsmöglichkeiten
- Inverse Bestückung möglich
- Bemessungsspannung bis 1000 V
- Kostengünstig
- *High combination possibilities*
- *Possibility of inverse configuration*
- *Rated voltage up to 1000 V*
- *Low cost*

Hoher Schutz vor Fehlsteckungen

High protection against mismatching

- Buchsenkontakteinsatz mit trichterförmiger, verengter Stecköffnung.
- Hohe Steck- und Kontaktsicherheit bei 10 pol. Modul mit gestanzten Kontakten.
- *Female inserts with funnel shaped contact entry avoids mismatching.*
- *High security in mating and contacting with stamped crimp contacts for 10 pin module.*

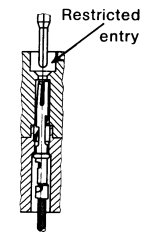

10 pol. Module für gestanzte Kontakte und für gedrehte Kontakte

10 pin modules for stamped contacts and for turned contacts

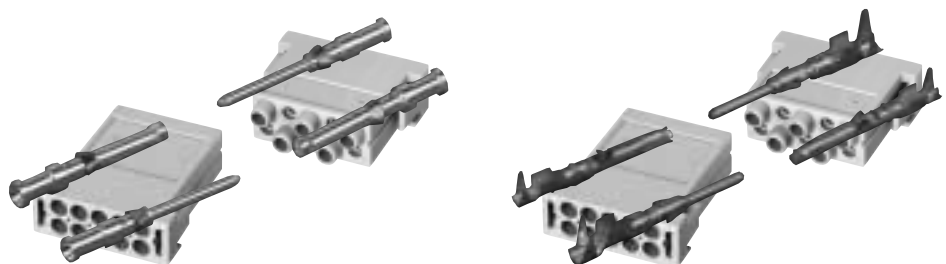

Voreilender Schutzkontakt Mindest Anschlussquerschnitt 0,5 mm²

First-to-mate last-to-break protective ground contact Minimum wire size 0,5 mm²

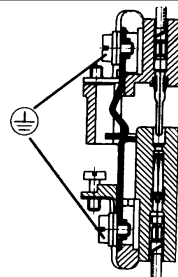





Große Gehäuseauswahl in 2 Bauhöhen (ab Seite 132)

Large range of housings in 2 different heights (see page 132)

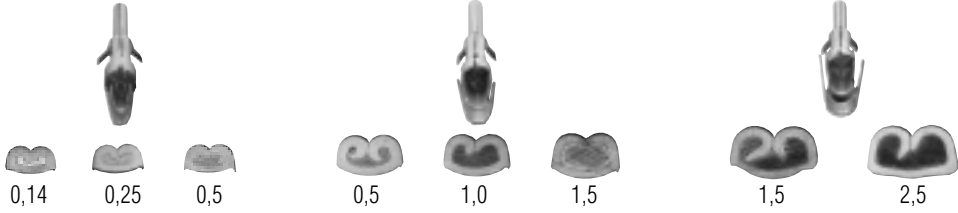

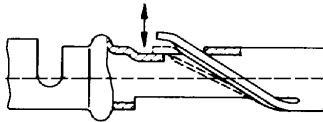
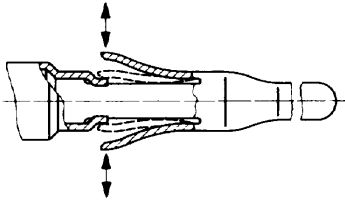
Hauptmerkmale der gestanzten Crimpkontakte
Main characteristics of the stamped crimp contacts

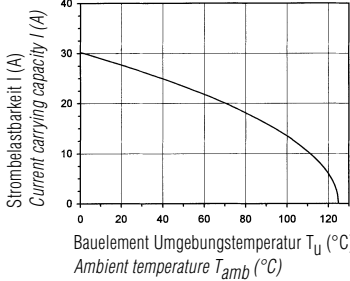
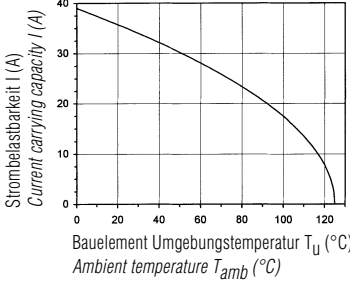
<p>Großer Crimpbereich <i>Large range of wire gauges</i></p> <p>Gasdichte Verbindung (Kaltverschweißung) <i>Gas-tight (coldwelding)</i></p>	<p>.N01 016 0003 (1) ¹⁾ .N01 016 0002 (1) ¹⁾ .N01 016 0005 (1) ¹⁾</p>  <p>0,14 0,25 0,5 0,5 1,0 1,5 1,5 2,5</p>
<p>Gestanzte Crimpkontakte mit Isolierungshalterung um mechanische Beanspruchung von der Crimpverbindung fernzuhalten <i>Stamped crimp contacts with insulation crimp, to absorb mechanical stress from the crimped connection</i></p>	 <p>Isolierungshalterung <i>Insulation grip</i></p>
<p>Mechanischer Rasthakenanschlag bei Buchsen- und Stiftkontakt <i>Mechanical retention spring stop on female and male contact</i></p> <p>Einfache Montage <i>Easy assembly</i></p>	<p>Buchsenkontakt <i>Female contact</i></p>  <p>Stiftkontakt <i>Male contact</i></p> 
<p>Kostengünstige, einfache Verarbeitung Werkzeuge siehe Katalog „Werkzeuge“ <i>Economical and easy processing Tools see catalogue „Tools“</i></p>	 <p>Service-Anwendungen <i>Service application</i></p> <p>Einzel-Fertigung <i>Single production</i></p> <p>Kleinserie <i>Small series</i></p> <p>Serie <i>Series</i></p>
<p>Hohe Strombelastbarkeit (siehe Derating Kurven) <i>High current carrying capacity (see derating curves)</i></p>	<p>Beispiel Einzelkontakt / <i>Example single contact</i></p>  <p>Strombelastbarkeit I (A) <i>Current carrying capacity I (A)</i></p> <p>Bauelement Umgebungstemperatur T_U (°C) <i>Ambient temperature T_{amb} (°C)</i></p> <p>Standardkontakt, Anschlussquerschnitt 2,5 mm² <i>Standard contact, wire gauge 2.5 mm²</i></p>  <p>Strombelastbarkeit I (A) <i>Current carrying capacity I (A)</i></p> <p>Bauelement Umgebungstemperatur T_U (°C) <i>Ambient temperature T_{amb} (°C)</i></p> <p>Hochstromkontakt, Anschlussquerschnitt 2,5 mm² <i>High current contact, wire gauge 2.5 mm²</i></p>

¹⁾ Erläuterung der Bestell-Nr. für die Kontakte siehe Seite 4
¹⁾ Explanation of the Part No. of contacts see page 4

C 146 M

Bestellverfahren How to order

Auswahl <i>Choice</i>		Beispiel Bestell Nr. <i>Example Part No.</i>
1) Rahmen <i>Frames</i>		C146 P16 001 G8
2) Module <i>Modules</i>		C146 A03 001 E8
3) Kontakte <i>Contacts</i>		VN01 036 0002 1C
4) Werkzeug <i>Tool</i>		TA 0000 + TA 0000 124 + TA 0010 146 004
5) Gehäuse <i>Housings</i>		C146 10G016 500 8

Allgemeine Kennwerte	General Characteristics									
Modul	Module	1	2	3	4	5	6	7	8	9
Polzahl	<i>Number of contacts</i>	20	10	10 ¹⁾	5	3	4 + ⊕ / 5	3	3	5
Kontakt Durchmesser in mm	<i>Contact diameter in mm</i>	1,0	1,6	1,6	2,5	3,6	2,5	3,6 Koax	3,6	2,5
Crimpkontakt	<i>Crimp contact</i>	gestanzt <i>stamped</i>	gestanzt <i>stamped</i>	gedreht <i>turned</i>	gedreht <i>turned</i>	gedreht <i>turned</i>	gestanzt <i>stamped</i>	gedreht <i>turned</i>	gedreht <i>turned</i>	gedreht <i>turned</i>
Anschlussart	<i>Termination technique</i>	crimpen / <i>crimp</i>								
Brennbarkeit	<i>Flammbarkeit</i>	V-0								
Elektrische Kennwerte	Electrical Characteristics									
Bemessungsspannung ²⁾	<i>Rated voltage ²⁾</i>	63 V	250 V	250 V	400 V	630 V	1000 V	250 V	1000 V	400 V
Verschmutzungsgrad ²⁾	<i>Pollution degree ²⁾</i>	3	3	3	3	3	3	3	3	3
Bemessungs-Stoßspannung ²⁾	<i>Rated impulse withstand voltage ²⁾</i>	4,0 kV	4,0 kV	4,0 kV	6,0 kV	8,0 kV	8,0 kV		8,0 kV	6,0 kV
Isolierstoffgruppe ²⁾ (PA)	<i>Material group ²⁾ (PA)</i>	II	II	II	II	II	II	II	II	II
Spannungsfestigkeit ³⁾	<i>Voltage proof ³⁾</i>	1680 V	2110 V	2110 V	3510 V	4260 V	5700 V		5700 V	3510 V
Bemessungsstrom T _U = 40 °C	<i>Rated current T_{amb} = 40 °C</i>	5 A	10 A	10 A	20 A	50 A	16 A		50 A	20 A
Strombelastbarkeit ⁴⁾	<i>Current carrying capacity ⁴⁾</i>	siehe Derating Kurven / <i>see derating curves</i>								
Isolationswiderstand ³⁾	<i>Insulation resistance ³⁾</i>	≥ 10 ¹² Ω								
Durchgangswiderstand ³⁾	<i>Contact resistance ³⁾</i>	< 5 mΩ								
Klimatische Kennwerte	Climatical Characteristics									
Temperaturbereich	<i>Temperatur range</i>	-40 °C - +125 °C	-40 °C +100 °C	- 40 °C / + 125 °C						
Mechanische Kennwerte	Mechanical Characteristics									
Steck- und Ziehkraft ⁵⁾	<i>Insertion and withdrawal forces ⁵⁾</i>	15 - 20 N (Rahmen / <i>frame</i>)								
⁶⁾ IP-Schutzart Stifteinsatz	<i>IP-degree of protection pin insert</i>	Norm/Standard IEC 60529				ungesteckt/ <i>unmated</i> IP00			gesteckt/ <i>mated</i> IP20	
⁶⁾ IP-Schutzart Buchseneinsatz	<i>IP-degree of protection socket insert</i>	Norm/Standard IEC 60529				ungesteckt/ <i>unmated</i> IP20			gesteckt/ <i>mated</i> IP20	
Werkstoffe	Materials									
Rahmen	<i>Frames</i>	PA 6.6 GF								
Module	<i>Modules</i>	PA 6.6 GF								
Farbe Rahmen	<i>Colour frames</i>	schwarz / <i>black</i>								
Farbe Module	<i>Colour modules</i>	schwarz / <i>black</i> / rotbraun / <i>redbrown</i>								
Kontakte	<i>Contacts</i>	Cu-Legierung / <i>Cu-alloy</i>								
Kontaktoberfläche	<i>Contact plating</i>	Au	Ag					Au	Ag	

¹⁾ auch LWL Kontakte möglich 1,0 mm POF / *also FO 1,0 mm contacts available*

²⁾ nach IEC 60664-1 / *according to IEC 60664-1*

³⁾ nach IEC 60512-2 / *according to IEC 60512-2*

⁴⁾ nach IEC 60512-3 / *according to IEC 60512-3*

⁵⁾ nach IEC 60512-7 / *according to IEC 60512-7*

⁶⁾ Ausnahme Stifteinsatz IP 20 siehe Module / *Exception pin insert IP 20 see modules*

C 146 M

Module Übersicht Modules Overview



Stiftmodul / pin module

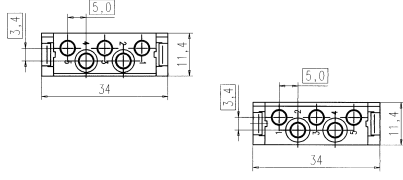

Buchsenmodul / socket module

Bezeichnung - Abbildung Description - Figure	Nr. No.	Maßzeichnung Drawing	Bestell Nr. / Part No.	
			Stiftmodule / Pin module	Buchsenmodule / Socket module
20 pol. für gestanzte Kontakte 20 contacts for stamped contacts 	1		C146 A20 001 G8	C146 B20 001 G8
10 pol. für gestanzte Kontakte 10 contacts for stamped contacts 	2		C146 D10 001 E8	C146 C10 001 G8
10 pol. für gedrehte Kontakte 10 contacts for turned contacts 	3		C146 A10 001 E8	C146 B10 001 E8
5 pol. für gedrehte Kontakte 5 contacts for turned contacts 	4		C146 A05 001 E8 ¹⁾	C146 B05 001 E8 ¹⁾
3 pol. für gedrehte Kontakte 3 contacts for turned contacts 	5		C146 A03 001 E8	C146 B03 001 E8
5 pol. für gestanzte Kontakte 5 contacts for stamped contacts 	6		C146 D04 001 E8 (4 pol) C146 D05 001 E8 (4 + PE) C146 D05 801 E8 (5 pol)	C146 C04 001 E8 (4 pol) C146 C05 001 E8 (4 + PE) C146 C05 801 E8 (5 pol)
3 pol. für Koax Kontakte 3 contacts for coax contacts 	7		C146 A03 501 E8	C146 B03 501 E8
3 pol. für gedrehte Kontakte 3 contacts for turned contacts 	8		C146 A03 801 E8	C146 B03 801 E8

C 146 M

Rahmen Frames

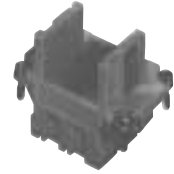

Gehäuse, siehe Seite 132–163
Housings, see page 132–163

Rahmen für Stiftmodule ¹⁾
Frame for pin modules ¹⁾

Rahmen für Buchsenmodule ¹⁾
Frame for socket modules ¹⁾

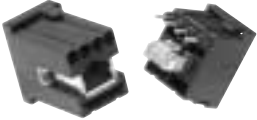
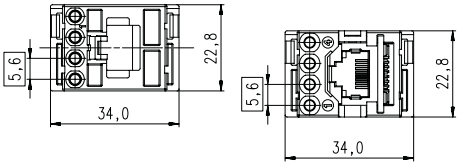
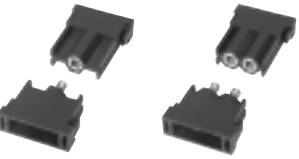
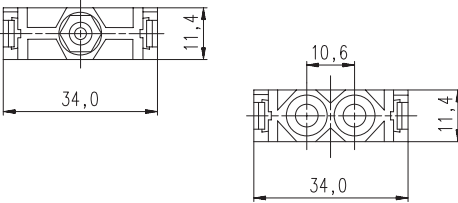
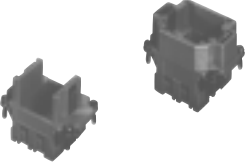
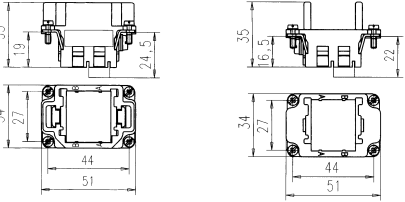
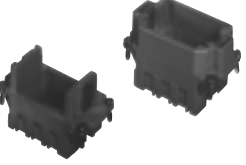
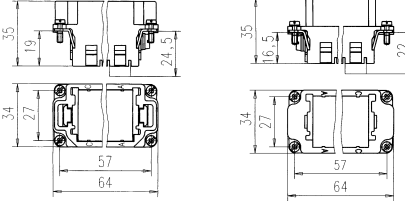
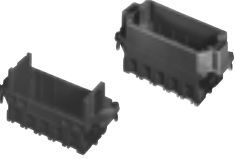
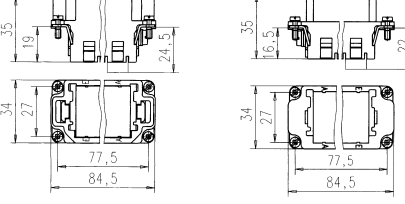
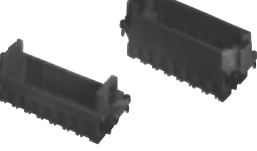
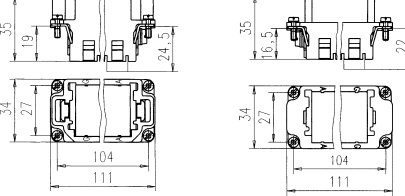
Bezeichnung - Abbildung Description - Figure	Maßzeichnung / Drawing	Bestell Nr. / Part No. ²⁾		
		Stiftmodule / pin module	Buchsenmodule/socket module	
RJ Modul RJ module 		C146 E12 001 E8	C146 F12 001 G8	
Pneu Modul, 1 oder 2 Verbindungen Pneumatic module, 1 or 2 connections 		C146 G01 014 G8 (2,5 mm) C146 G01 024 G8 (4,0 mm) C146 G02 014 G8 (2,5 mm) C146 G02 024 G8 (4,0 mm)	C146 H01 034 G8 (2,5 mm) C146 H01 044 G8 (4,0 mm) C146 H02 034 G8 (2,5 mm) C146 H02 044 G8 (4,0 mm)	
Bezeichnung - Abbildung Description - Figure	Maßzeichnung / Drawing	Kennzeich. Positions	Bestell Nr. / Part No. ²⁾	
	Rahmen für Stiftmodule Frame for pin modules Rahmen für Buchsenmodule Frame for socket module		Rahmen für Stiftmodule Frame for pin modules	Rahmen Buchsenmodule Frame for socket module
Rahmen für 2 Module Frame for 2 modules 		A - B	C146 P06 001 G8 C146 P06 002 G8 (2 x PE)	C146 S06 001 G8 C146 S06 002 G8 (2 x PE)
Rahmen für 3 Module Frame for 3 modules 		A - C	C146 P10 001 G8 C146 P10 002 G8 (2 x PE)	C146 S10 001 G8 C146 S10 002 G8 (2 x PE)
Rahmen für 5 Module Frame for 5 modules 		A - E	C146 P16 001 G8 C146 P16 002 G8 (2 x PE)	C146 S16 001 G8 C146 S16 002 G8 (2 x PE)
Rahmen für 7 Module Frame for 7 modules 		A - G T - Z	C146 P24 001 G8 C146 P24 002 G8 (2 x PE) C146 P24 101 G8 C146 P24 102 G8 (2 x PE)	C146 S24 001 G8 C146 S24 002 G8 (2 x PE) C146 S24 101 G8 C146 S24 102 G8 (2 x PE)

¹⁾ Im Rahmen für Stiftmodule können auch Buchsenmodule gesteckt werden (inverse Bestückung möglich).

¹⁾ It is possible to mount socket modules in frames for pin modules (possibility of inverse configuration).

²⁾ Für den Einbau der Steckverbinder in nicht leitende Gehäuse sind beide Schutzleiter (Ausführung 2 x PE) anzuschließen.

²⁾ If connectors are mounted in non conductive housings both protective earthing terminals shall be mounted.

C 146 M 20 pol

Technische Daten Characteristics

Allgemeine Kennwerte	General Characteristics	Norm / Standard	Wert / Value
Polzahl	Number of contacts		20
Anschluss technik	Termination technique		crimpen / crimp
Anschlussquerschnitt	Wire gauge		0,09 - 0,5 mm ² (AWG 28 - 20)
Brennbarkeit	Flammability	UL 94	V-0
Elektrische Kennwerte	Electrical Characteristics		
Bemessungsspannung	Rated voltage	IEC 60664-1	63 V
Verschmutzungsgrad	Pollution degree	IEC 60664-1	3
Überspannungskategorie	Installation (overvoltage) category	IEC 60664-1	III
Isolierstoffgruppe	Material group	IEC 60664-1	II (PA)
Bemessungs-Stoßspannung	Rated impulse withstand voltage	IEC 60664-1	4,0 kV
Spannungsfestigkeit	Voltage proof	IEC 60512-2; Test 4 a	1,68 kV
Strombelastbarkeit	Current carrying capacity	IEC 60512-3; Test 5 b	siehe Derating Kurven / see derating curves
Durchgangswiderstand	Contact resistance	IEC 60512-2; Test 2 a	≤ 5 mΩ
Isolationswiderstand	Insulation resistance	IEC 60512-2; Test 3 a	≥ 10 ¹² Ω ²⁾
Luftstrecke	Clearance	IEC 60664-1	> 2,4 mm
Kriechstrecke	Creepage	IEC 60664-1	> 2,4 mm
Klimatische Kennwerte	Climatical Characteristics		
Prüfklasse	Climatic category	IEC 60068-1	40 / 125 / 21
Obere Grenztemperatur	Upper temperature	IEC 60512-6; Test 11 i	+ 125 °C / 1000 h
Untere Grenztemperatur	Lower temperature	IEC 60512-6; Test 11 i	- 40 °C / 16 h
Mechanische Kennwerte	Mechanical Characteristics		
Steck- und Ziehkraft ¹⁾	Insertion and withdrawal forces ¹⁾	IEC 60512-7; Test 13 b	10 - 15 N
Mechanische Lebensdauer	Mechanical operation	IEC 60512-5; Test 9 a	≥ 500 Steckzyklen / mating cycles
Werkstoffe	Materials		
Kontakteinsatz	Insert		PA 6.6 GF
Farbe	Colour		schwarz / black
Kontakte Stift / Buchse	Contacts male / female		CuZn (Messing/brass) / CuSn (Bronze/bronze)
Kontakt oberfläche	Contact plating		Au (gold / gold)

¹⁾ für ein Modul / for one module

²⁾ bei Beanspruchung >10¹⁰ Ω / under operating condition >10¹⁰ Ω

Derating Kurven / Derating curves

0,25 mm²

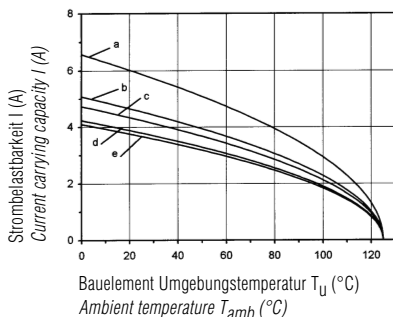

0,5 mm²

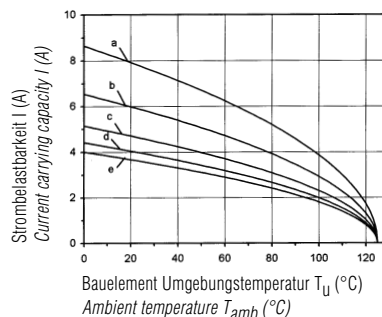

Kurve Curve	Polzahl Contacts	Rahmen Frame
a	20	2 Module
b	40	2 Module
c	60	3 Module
d	100	5 Module
e	140	7 Module

C 146 M 20 pol

Module
Modules



Bandkontakte für Crimpzangen
Contacts on reel for hand crimping tools



350 Stück
350 pcs

für gestanzte 1,0 mm Kontakte
for stamped 1,0 mm contacts

Bandkontakte für Crimpmaschinen
Contacts on reel for crimp machines



2000 Stück
(Zuführung links)
2000 pcs
(feeding left hand side)

Abbildung Figure	Maßzeichnung / Drawing		Bestell Nr. / Part No.	
	Stiftmodul / Pin module	Buchsenmodul / Socket module	Stiftmodul / Pin module	Buchsenmodul / Socket module
			C146 A20 001 G8	C146 B20 001 G8

Crimpkontakte / Crimp contacts

Lieferform Supplied as	für Leiterquerschnitt for wire gauge	AWG	Stückzahl Pieces	Bestell Nr. / Part No.	
				Stiftkontakt / Male contact	Buchsenkontakt / Female contact
Einzelkontakte für Crimpzangen / single contacts for hand crimping tools					
vergoldet / gold plating					
	0,09 - 0,25 mm ²	28 - 24	100	VN01 010 0130 (2)	VN02 010 0130 (2)
	0,25 - 0,50 mm ²	24 - 20	100	VN01 010 0131 (2)	VN02 010 0131 (2)
Bandkontakte für Crimpzangen / Contacts on reel for hand crimping tools					
	0,09 - 0,25 mm ²	28 - 24	500	ZN01 010 0130 (2)	ZN02 010 0130 (2)
	0,25 - 0,50 mm ²	24 - 20	500	ZN01 010 0131 (2)	ZN02 010 0131 (2)
Bandkontakte für Crimpmaschinen/ Contacts on reel for crimp machines					
Kontaktzuführung links Contact feeding left hand side	0,09 - 0,25 mm ²	28 - 24	2000	TN01 010 0130 (2)	TN02 010 0130 (2)
	0,25 - 0,50 mm ²	24 - 20	2000	TN01 010 0131 (2)	TN02 010 0131 (2)
	0,09 - 0,25 mm ²	28 - 24	10.000	FN01 010 0130 (2)	FN02 010 0130 (2)
	0,25 - 0,50 mm ²	24 - 20	10.000	FN01 010 0131 (2)	FN02 010 0131 (2)

Werkzeuge / Tools¹⁾

Bezeichnung / Description	für Leiterquerschnitt for wire gauge	Kontaktaufnahme / Contact locator	Crimpbacken / Crimping dies	Bestell Nr. / Part No.
				Werkzeuge / Tools
Lösewerkzeug für Kontakte Removal tool for contacts	—	—	—	17D 438 SP
Lösewerkzeug für Module Removal tool for modules	—	—	—	FG 1000 146
Service Crimpzange Service crimping tool	0,09 - 0,25 mm ² 0,25 - 0,50 mm ²	—	—	TA 0200 146

Bei kleinen Leiterquerschnitten wird der Einsatz von Führungselementen empfohlen (siehe Seite 184)
If small wire sizes are used, guide pins and guide sockets should be preferred to use (see page 184)

¹⁾Weitere Informationen siehe Katalog „Werkzeuge“ / Further information see catalogue „Tools“

Abisolierlängen siehe S. 208
Stripping length see p. 208

C 146 M 10 pol

Technische Daten
Characteristics

Module für gestanzte Kontakte
Modules for stamped contacts

Allgemeine Kennwerte	General Characteristics	Norm / Standard	Wert / Value
Polzahl	Number of contacts		10
Anschluss technik	Termination technique		crimpen / crimp
Anschlussquerschnitt	Wire gauge		0,14 - 2,5 mm ² (AWG 26 - 14)
Brennbarkeit	Flammability	UL 94	V-0
Elektrische Kennwerte	Electrical Characteristics		
Bemessungsspannung	Rated voltage	IEC 60664-1	250 V
Verschmutzungsgrad	Pollution degree	IEC 60664-1	3
Überspannungskategorie	Installation (overvoltage) category	IEC 60664-1	II (PA)
Isolierstoffgruppe	Material group	IEC 60664-1	III a
Bemessungs-Stoßspannung	Rated impulse withstand voltage	IEC 60664-1	4,0 kV
Spannungsfestigkeit	Voltage proof	IEC 60512-2; Test 4 a	2,11 kV
Strombelastbarkeit	Current carrying capacity	IEC 60512-3; Test 5 b	siehe Derating Kurven / see derating curves
Durchgangswiderstand	Contact resistance	IEC 60512-2; Test 2 a	≤ 5 mΩ
Isolationswiderstand	Insulation resistance	IEC 60512-2; Test 3 a	≥ 10 ¹² Ω ²⁾
Luftstrecke / Kriechstrecke	Clearance / Creepage	IEC 60664-1	> 4,3 mm
Klimatische Kennwerte	Climatical Characteristics		
Prüfklasse	Climatic category	IEC 60068-1	40 / 125 / 21
Obere Grenztemperatur	Upper temperature	IEC 60512-6; Test 11 i	+ 125 °C / 1000 h
Untere Grenztemperatur	Lower temperature	IEC 60512-6; Test 11 i	- 40 °C / 16 h
Mechanische Kennwerte	Mechanical Characteristics		
Steck- und Ziehkraft ¹⁾	Insertion and withdrawal forces ¹⁾	IEC 60512-7; Test 13 b	20 - 25 N
Mechanische Lebensdauer	Mechanical operation	IEC 60512-5; Test 9 a	≥ 500 Steckzyklen / mating cycles
Werkstoffe	Materials		
Modul	Module		PA 6.6 GF
Farbe	Colour		schwarz / black
Stiftkontakt	Male contact		CuZn (Messing/brass)
Buchsenkontakt	Female contact		CuSn (Bronze/bronze)
Kontaktoberfläche	Contact plating		Ag (silber/silver)

¹⁾ für ein Modul / for one module

²⁾ bei Beanspruchung >10¹⁰ Ω / under operating condition >10¹⁰ Ω

Derating Kurven / Derating curves

0,5 mm²

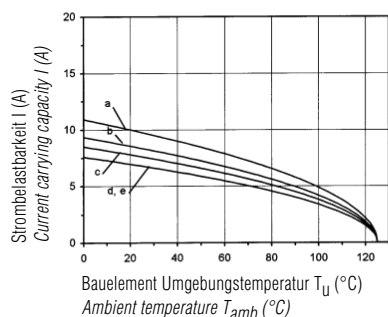

1,5 mm²

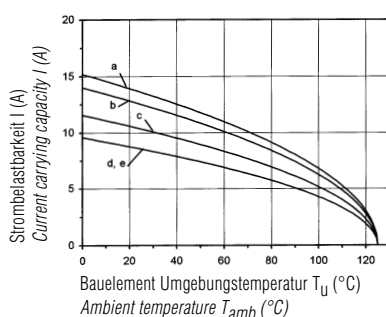

Kurve Curve	Polzahl Contacts	Rahmen Frame
a	10	2 Module
b	20	2 Module
c	30	3 Module
d	50	5 Module
e	70	7 Module

C 146 M 10 pol

Module
Modules

gestanzte Einzelkontakte
Stamped single contacts



Bandkontakte für Crimpzangen
Contacts on reel for hand crimping tools



200 / 100 Stück
200 / 100 pcs

Bandkontakte für Crimpmaschinen
Contacts on reel for crimp machines



2000 Stück
(Zuführung links
oder rechts)
2000 pcs
(feeding left or
right hand side)

für gestanzte 1,6 mm Kontakte
for stamped 1,6 mm contacts

Abbildung Figure	Maßzeichnung / Drawing		Bestell Nr. / Part No.	
	Stiftmodul / Pin module	Buchsenmodul / Socket module	Stiftmodul / Pin module	Buchsenmodul / Socket module
			C146 D10 001 E8	C146 C10 001 G8

Crimpkontakte / Crimp contacts

Lieferform Supplied as	für Leiter- querschnitt for wire gauge	AWG	Stück- zahl Pieces	Bestell Nr. ¹⁾		Bestell Nr. ¹⁾		
				Stiftkontakt Male contact	Buchsenkontakt Female contact	Stiftkontakt Male contact	Buchsenkontakt Female contact	
Gestanzte Einzelkontakte / Stamped single contacts				versilbert / silver plating		vergoldet / gold plating		
Standard Hochstrom High current	0,14 - 0,5 mm ²	26 - 20	100	VN01 016 0003 (1)	VN02 016 0003 (1)	VN01 016 0003 (2)	VN02 016 0003 (2)	
	0,5 - 1,5 mm ²	20 - 16	100	VN01 016 0002 (1)	VN02 016 0002 (1)	VN01 016 0002 (2)	VN02 016 0002 (2)	
	1,5 - 2,5 mm ²	16 - 14	100	VN01 016 0005 (1)	VN02 016 0005 (1)	VN01 016 0005 (2)	VN02 016 0005 (2)	
	0,5 - 1,5 mm ²	20 - 16	100	VN01 016 0015 (1)	VN02 016 0015 (1)			
	1,5 - 2,5 mm ²	16 - 14	100	VN01 016 0016 (1)	VN02 016 0016 (1)			
Gestanzte Bandkontakte für Crimpzangen / Stamped Contacts on reel for hand crimp tools								
Standard Hochstrom High current	0,14 - 0,5 mm ²	26 - 20	200	ZN01 016 0003 (1)	ZN02 016 0003 (1)	ZN01 016 0003 (2)	ZN02 016 0003 (2)	
	0,5 - 1,5 mm ²	20 - 16	200	ZN01 016 0002 (1)	ZN02 016 0002 (1)	ZN01 016 0002 (2)	ZN02 016 0002 (2)	
	1,5 - 2,5 mm ²	16 - 14	100	ZN01 016 0005 (1)	ZN02 016 0005 (1)	ZN01 016 0005 (2)	ZN02 016 0005 (2)	
	0,5 - 1,5 mm ²	20 - 16	200	ZN01 016 0015 (1)	ZN02 016 0015 (1)			
	1,5 - 2,5 mm ²	16 - 14	100	ZN01 016 0016 (1)	ZN02 016 0016 (1)			
Gestanzte Bandkontakte für Crimpmaschinen / Stamped contacts on reel for crimp machines								
Kontaktzuführung rechts Contact feeding right hand side	0,14 - 0,5 mm ²	26 - 20	2000	HN01 016 0003 (1)	HN02 016 0003 (1)	HN01 016 0003 (2)	HN02 016 0003 (2)	
	0,5 - 1,5 mm ²	20 - 16	2000	HN01 016 0002 (1)	HN02 016 0002 (1)	HN01 016 0002 (2)	HN02 016 0002 (2)	
	Standard	1,5 - 2,5 mm ²	16 - 14	2000	HN01 016 0005 (1)	HN02 016 0005 (1)	HN01 016 0005 (2)	HN02 016 0005 (2)
	Hochstrom High current	0,5 - 1,5 mm ²	20 - 16	2000	HN01 016 0015 (1)	HN02 016 0015 (1)		
		1,5 - 2,5 mm ²	16 - 14	2000	HN01 016 0016 (1)	HN02 016 0016 (1)		
Kontaktzuführung links Contact feeding left hand side	0,14 - 0,5 mm ²	26 - 20	2000	TN01 016 0003 (1)	TN02 016 0003 (1)	TN01 016 0003 (2)	TN02 016 0003 (2)	
	0,5 - 1,5 mm ²	20 - 16	2000	TN01 016 0002 (1)	TN02 016 0002 (1)	TN01 016 0002 (2)	TN02 016 0002 (2)	
	Standard	1,5 - 2,5 mm ²	16 - 14	2000	TN01 016 0005 (1)	TN02 016 0005 (1)	TN01 016 0005 (2)	TN02 016 0005 (2)
	Hochstrom High current	0,5 - 1,5 mm ²	20 - 16	2000	TN01 016 0015 (1)	TN02 016 0015 (1)		
		1,5 - 2,5 mm ²	18 - 14	2000	TN01 016 0016 (1)	TN02 016 0016 (1)		

Werkzeuge / Tools²⁾

Bezeichnung / Description	für Leiterquerschnitt for wire gauge	Bestell Nr. / Part No.		
		Kontaktaufnahme / Contact locator	Crimpbacken / Crimping dies	Werkzeuge / Tools
Lösewerkzeug für Kontakte / Module Removal tool for contacts / modules	–	–	–	FG 0300 146 1 / FG 1000 146
Service Crimpzange Service crimping tool	0,14 - 0,5 mm ² 0,5 - 1,5 mm ²	–	–	TA 0100 146
Crimpzange für Einzelkontakte Crimping tool for single contacts	0,14 - 0,5 mm ² 0,5 - 1,5 mm ² 1,5 - 2,5 mm ²	TA 0001 146 000 1 TA 0002 146 000 1 TA 0007 146 000 3	TA 0000 202 TA 0000 163 TA 0000 141	TA 0000

¹⁾ Erläuterung der Bestell-Nr. für die Kontakte siehe Seite 4 / Explanation of the Part No. for contacts see page 4

²⁾ Weitere Informationen siehe Katalog „Werkzeuge“ / Further information see catalogue „Tools“

Abisolierlängen siehe S. 208
Stripping length see p. 208

C 146 M 10 pol

Technische Daten Characteristics

für gedrehte 1,6 mm Kontakte for turned 1,6 mm contacts

Allgemeine Kennwerte	General Characteristics	Norm / Standard	Wert / Value
Polzahl	Number of contacts		10
Anschluss technik	Termination technique		crimpen / crimp
Anschlussquerschnitt	Wire gauge		0,14 - 2,5 mm ² (AWG 26 - 14)
Brennbarkeit	Flammability	UL 94	V-0
Elektrische Kennwerte	Electrical Characteristics		
Bemessungsspannung	Rated voltage	IEC 60664-1	250 V
Verschmutzungsgrad	Pollution degree	IEC 60664-1	3
Überspannungskategorie	Installation (overvoltage) category	IEC 60664-1	III
Isolierstoffgruppe	Material group	IEC 60664-1	II (PA)
Bemessungs-Stoßspannung	Rated impulse withstand voltage	IEC 60664-1	4,0 kV
Spannungsfestigkeit	Voltage proof	IEC 60512-2; Test 4 a	2,21 kV
Strombelastbarkeit	Current carrying capacity	IEC 60512-3; Test 5 b	siehe Derating Kurven / see derating curves
Durchgangswiderstand	Contact resistance	IEC 60512-2; Test 2 a	≤ 5 mΩ
Isolationswiderstand	Insulation resistance	IEC 60512-2; Test 3 a	≥ 10 ¹² Ω ²⁾
Luftstrecke	Clearance	IEC 60664-1	> 4,3 mm
Kriechstrecke	Creepage	IEC 60664-1	> 4,3 mm
Klimatische Kennwerte	Climatical Characteristics		
Prüfklasse	Climatic category	IEC 60068-1	40 / 100 / 21
Obere Grenztemperatur	Upper temperature	IEC 60512-6; Test 11 i	+ 100 °C / 1000 h
Untere Grenztemperatur	Lower temperature	IEC 60512-6; Test 11 i	- 40 °C / 16 h
Mechanische Kennwerte	Mechanical Characteristics		
Steck- und Ziehkraft ¹⁾	Insertion and withdrawal forces ¹⁾	IEC 60512-7; Test 13 b	25 - 30 N
Mechanische Lebensdauer	Mechanical operation	IEC 60512-5; Test 9 a	≥ 500 Steckzyklen / mating cycles
Werkstoffe	Materials		
Modul	Module		PA 6.6 GF
Farbe	Colour		schwarz / black
Kontakte	Contacts		CuZn (Messing / brass)
Kontaktoberfläche	Contact plating		Ag (silber / silver)

¹⁾ für ein Modul / for one module

²⁾ bei Beanspruchung >10¹⁰ Ω / under operating condition >10¹⁰ Ω

Derating Kurven / Derating curves

0,5 mm²

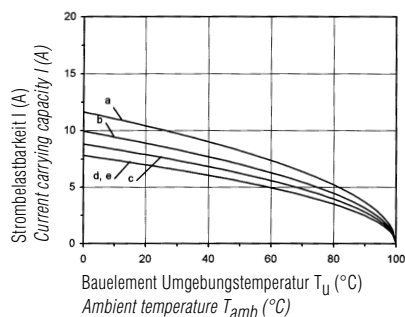

1,5 mm²

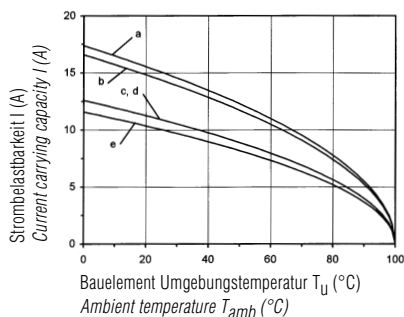

Kurve Curve	Polzahl Contacts	Rahmen Frame
a	10	2 Module
b	20	2 Module
c	30	3 Module
d	50	5 Module
e	70	7 Module

C 146 M 10 pol

Module
Modules

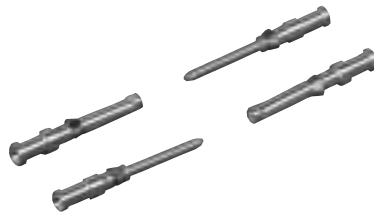

für gedrehte 1,6 mm Kontakte
for turned 1,6 mm contacts



LWL-Kontakte
FO-contacts

Abbildung Figure	Maßzeichnung / Drawing Stiftmodul / Pin module Buchsenmodul / Socket module	Bestell Nr. / Part No.	
		Stiftmodul / Pin module	Buchsenmodul / Socket module
		C146 A10 001 E8	C146 B10 001 E8

Crimpkontakte / Crimp contacts

Lieferform Supplied as	für Leiterquerschnitt for wire gauge	AWG	Stückzahl Pieces	Bestell Nr. ¹⁾ / Part No. ¹⁾		Bestell Nr. ¹⁾ / Part No. ¹⁾	
				Stiftkontakt Male contact	Buchsenkontakt Female contact	Stiftkontakt Male contact	Buchsenkontakt Female contact
Gedrehte Crimpkontakte / Turned crimp contacts				versilbert / silver plating		vergoldet / gold plating	
Einzelkontakte Single contact	0,14 - 0,37 mm ²	26 - 22	100	VN01 016 0024 (1)C	VN02 016 0024 (1)C	VN01 016 0024 (2)C	VN02 016 0024 (2)C
	0,5 mm ²	20	100	VN01 016 0025 (1)C	VN02 016 0025 (1)C	VN01 016 0025 (2)C	VN02 016 0025 (2)C
	0,75 - 1,0 mm ²	20 - 16	100	VN01 016 0026 (1)C	VN02 016 0026 (1)C	VN01 016 0026 (2)C	VN02 016 0026 (2)C
	1,5 mm ²	16 - 15	100	VN01 016 0027 (1)C	VN02 016 0027 (1)C	VN01 016 0027 (2)C	VN02 016 0027 (2)C
	2,5 mm ²	14	100	VN01 016 0028 (1)C	VN02 016 0028 (1)C	VN01 016 0028 (2)C	VN02 016 0028 (2)C

LWL Kontakte / FO contacts

Lieferform Supplied as	für Leiterquerschnitt for wire gauge	AWG	Stückzahl Pieces	Bestell Nr. ¹⁾ / Part No. ¹⁾	
				Stiftkontakt / Male contact	Buchsenkontakt / Female contact
Crimpkontakte / Crimp contacts					
Einzelkontakt / Single contact	1,0 mm POF/FO	–	10	VN01 016 0040 (8) X	VN02 016 0040 (8) X

Werkzeuge / Tools²⁾

Bezeichnung / Description	für Leiterquerschnitt for wire gauge	Bestell Nr. / Part No.		
		Kontaktaufnahme / Contact locator	Crimpbacken / crimping dies	Werkzeuge / Tools
Lösewerkzeug für Kontakte Removal tool for contacts	–	–	–	FG 0300 146 1
Lösewerkzeug für Module Removal tool for modules	–	–	–	FG 1000 146
Crimpzange für Einzelkontakte Crimping tool for single contacts	0,14 - 1,0 mm ² 1,5 mm ² 2,5 mm ²	TA 0010 146 000 1	TA 0000 184	TA 0000
Crimpzange für LWL Kontakte ³⁾ Crimping tool for FO contacts ³⁾	1,0 mm POF/FO			TB 0500 146

¹⁾ Erläuterung der Bestell-Nr. für die Kontakte siehe Seite 4 / Explanation of the Part No. for contacts see page 4

²⁾ Weitere Informationen siehe Katalog „Werkzeuge“ / Further information see catalogue „Tools“

³⁾ incl. Abisolierwerkzeug, Kontaktaufnahme, Schleiflehre / incl. stripping tool, locator, abrasive adapter

Abisolierlängen siehe S. 208
Stripping length see p. 208

C 146 M

5 pol

Technische Daten Characteristics

Allgemeine Kennwerte	General Characteristics	Norm / Standard	Wert / Value
Polzahl	Number of contacts		5
Anschluss technik	Termination technique		crimpen / crimp
Anschlussquerschnitt	Wire gauge		0,5 - 4,0 mm ² (AWG 20 - 12)
Brennbarkeit	Flammability	UL 94	V-0
Elektrische Kennwerte	Electrical Characteristics		
Bemessungsspannung	Rated voltage	IEC 60664-1	400 V
Verschmutzungsgrad	Pollution degree	IEC 60664-1	3
Überspannungskategorie	Installation (overvoltage) category	IEC 60664-1	III
Isolierstoffgruppe	Material group	IEC 60664-1	II
Bemessungs-Stoßspannung	Rated impulse withstand voltage	IEC 60664-1	6,0 kV
Spannungsfestigkeit	Voltage proof	IEC 60512-2; Test 4 a	3,51 kV
Strombelastbarkeit	Current carrying capacity	IEC 60512-3; Test 5 b	siehe Derating Kurven / see derating curves
Durchgangswiderstand	Contact resistance	IEC 60512-2; Test 2 a	≤ 2 mΩ
Isolationswiderstand	Insulation resistance	IEC 60512-2; Test 3 a	≥ 10 ¹² Ω ²⁾
Luftstrecke	Clearance	IEC 60664-1	5,8 mm
Kriechstrecke	Creepage	IEC 60664-1	5,8 mm
Klimatische Kennwerte	Climatical Characteristics		
Prüfklasse	Climatic category	IEC 60068-1	40 / 125 / 21
Obere Grenztemperatur	Upper temperature	IEC 60512-6; Test 11 i	+ 125 °C / 1000 h
Untere Grenztemperatur	Lower temperature	IEC 60512-6; Test 11 i	- 40 °C / 16 h
Mechanische Kennwerte	Mechanical Characteristics		
Steck- und Ziehkraft ¹⁾	Insertion and withdrawal forces ¹⁾	IEC 60512-7; Test 13 b	25 - 30 N
Mechanische Lebensdauer	Mechanical operation	IEC 60512-5; Test 9 a	≥ 500 Steckzyklen / mating cycles
Werkstoffe	Materials		
Modul	Module		PA 6.6 GF
Farbe	Colour		schwarz
Kontakte	Contacts		Cu-Legierung / Cu-alloy
Kontaktoberfläche	Contact plating		Ag (silber / silver)

¹⁾ für ein Modul / for one module

²⁾ bei Beanspruchung >10¹⁰ Ω / under operating condition >10¹⁰ Ω

Derating Kurven / Derating curves

2,5 mm²

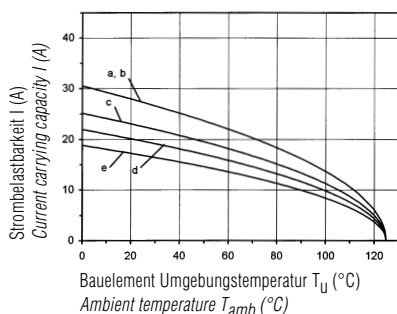

4 mm²

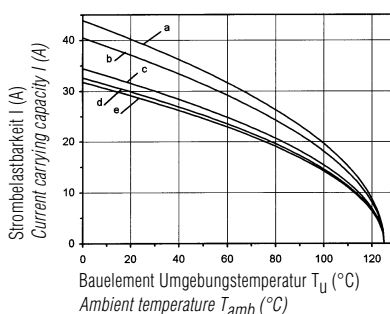

Kurve Curve	Polzahl Contacts	Rahmen Frame
a	5	2 Module
b	10	2 Module
c	15	3 Module
d	25	5 Module
e	35	7 Module

C 146 M 5 pol

Module
Modules

für gedrehte 2,5 mm Kontakte
for turned 2,5 mm contacts



Abbildung Figure	Maßzeichnung / Drawing		Bestell Nr. / Part No.	
	Stiftmodul / Pin module	Buchsenmodul / Socket module	Stiftmodul / Pin module	Buchsenmodul / Socket module
			C146 A05 001 E8	C146 B05 001 E8

Gedrehte Crimpkontakte / Turned crimp contacts

Lieferform Supplied as	für Leiter- querschnitt for wire gauge	AWG	Stück- zahl Pieces	Bestell Nr. ¹⁾		Bestell Nr. ¹⁾	
				Stiftkontakt Male contact	Buchsenkontakt Female contact	Stiftkontakt Male contact	Buchsenkontakt Female contact
Gedrehte Crimpkontakte / Turned crimp contacts				versilbert / silver plating		vergoldet / gold plating	
Einzelkontakte Single contact	0,5 mm ²	20	100	VN01 025 0029 (1)C	VN02 025 0029 (1)C	VN01 025 0029 (2)C	VN02 025 0029 (2)C
	0,75 - 1,0 mm ²	18	100	VN01 025 0030 (1)C	VN02 025 0030 (1)C	VN01 025 0030 (2)C	VN02 025 0030 (2)C
	1,5 mm ²	16	100	VN01 025 0031 (1)C	VN02 025 0031 (1)C	VN01 025 0031 (2)C	VN02 025 0031 (2)C
	2,5 mm ²	14	100	VN01 025 0032 (1)C	VN02 025 0032 (1)C	VN01 025 0032 (2)C	VN02 025 0032 (2)C
	4,0 mm ²	12	100	VN01 025 0033 (1)C	VN02 025 0033 (1)C	VN01 025 0033 (2)C	VN02 025 0033 (2)C

Werkzeuge / Tools²⁾

Bezeichnung / Description	für Leiterquerschnitt for wire gauge	Bestell Nr. / Part No.		
		Kontaktaufnahme / Contact locator	Crimpbacken / crimping dies	Werkzeuge / Tools
Lösewerkzeug für Kontakte Removal tool for contacts	–	–	–	FG 0300 146 4
Lösewerkzeug für Module Removal tool for modules	–	–	–	FG 1000 146
Crimpzange für Einzelkontakte Crimping tool for single contacts	0,5 - 2,5 mm ² 4,0 mm ²	TA 0010 146 000 2 TA 0010 146 000 3	TA 0000 144 TA 0000 124	TA 0000

¹⁾ Erläuterung der Bestell-Nr. für die Kontakte siehe Seite 4 / Explanation of the Part No. for contacts see page 4

²⁾ Weitere Informationen siehe Katalog „Werkzeuge“ / further information see catalogue „Tools“

Abisolierlängen siehe S. 208
Stripping length see p. 208

C 146 M 3 pol

Technische Daten Characteristics

Allgemeine Kennwerte	General Characteristics	Norm / Standard	Wert / Value
Polzahl	Number of contacts		3
Anschluss technik	Termination technique		crimpen / crimp
Anschlussquerschnitt	Wire gauge		1,5 - 10 mm ² (AWG 16 - 8)
Brennbarkeit	Flammability	UL 94	V-0
Elektrische Kennwerte	Electrical Characteristics		
Bemessungsspannung	Rated voltage	IEC 60664-1	630 V
Verschmutzungsgrad	Pollution degree	IEC 60664-1	3
Überspannungskategorie	Installation (overvoltage) category	IEC 60664-1	III
Isolierstoffgruppe	Material group	IEC 60664-1	II (PA)
Bemessungs-Stoßspannung	Rated impulse withstand voltage	IEC 60664-1	8,0 kV
Spannungsfestigkeit	Voltage proof	IEC 60512-2 Test 4 a	4,26 kV
Strombelastbarkeit	Current carrying capacity	IEC 60512-3; Test 5 b	siehe Derating Kurven / see derating curves
Durchgangswiderstand	Contact resistance	IEC 60512-2; Test 2 a	≤ 1 mΩ
Isolationswiderstand	Insulation resistance	IEC 60512-2; Test 3 a	≥ 10 ¹² Ω ²⁾
Luftstrecke	Clearance	IEC 60664-1	> 12 mm
Kriechstrecke	Creepage	IEC 60664-1	> 12 mm
Klimatische Kennwerte	Climatical Characteristics		
Prüfklasse	Climatic category	IEC 60068-1	40 / 125 / 21
Obere Grenztemperatur	Upper temperature	IEC 60512-6; Test 11 i	+ 125 °C / 1000 h
Untere Grenztemperatur	Lower temperature	IEC 60512-6; Test 11 i	- 40 °C / 16 h
Mechanische Kennwerte	Mechanical Characteristics		
Steck- und Ziehkraft ¹⁾	Insertion and withdrawal forces ¹⁾	IEC 60512-7; Test 13 b	20 - 30 N
Mechanische Lebensdauer	Mechanical operation	IEC 60512-5; Test 9 a	≥ 500 Steckzyklen / mating cycles
Werkstoffe	Materials		
Modul	Module		PA 6.6 GF
Farbe	Colour		schwarz / black
Kontakte	Contacts		Cu-Legierung / Cu-alloy
Kontaktoberfläche	Contact plating		Ag (silber / silver)

¹⁾ für ein Modul / for one module

²⁾ bei Beanspruchung >10¹⁰ Ω / under operating condition >10¹⁰ Ω

Derating Kurven / Derating curves

6 mm ²	10 mm ²	Kurve Curve	Polzahl Contacts	Rahmen Frame
<p>Bauelement Umgebungstemperatur T_U (°C) Ambient temperature T_{amb} (°C)</p>	<p>Bauelement Umgebungstemperatur T_U (°C) Ambient temperature T_{amb} (°C)</p>	a	3	2 Module
		b	6	2 Module
		c	9	3 Module
		d	15	5 Module
		e	21	7 Module

C 146 M 3 pol

Module
Modules

für gedrehte 3,6 mm Kontakte
for turned 3,6 mm contacts



Abbildung Figure	Maßzeichnung / Drawing		Bestell Nr. / Part No.	
	Stiftmodul / Pin module	Buchsenmodul / Socket module	Stiftmodul / Pin module	Buchsenmodul / Socket module
			C146 A03 001 E8	C146 B03 001 E8

Gedrehte Crimpkontakte / Turned crimp contacts

Lieferform Supplied as	für Leiterquerschnitt for wire gauge	AWG	Stückzahl Pieces	Bestell Nr. ¹⁾ / Part No. ¹⁾	
				Stiftkontakt / Male contact	Buchsenkontakt / Female contact
Gedrehte Crimpkontakte / Turned crimp contacts					
versilbert / silver plating					
Einzelkontakt Single contact	1,5 mm ²	16	100	VN01 036 0004 (1)C	VN02 036 0004 (1)C
	2,5 mm ²	14	100	VN01 036 0005 (1)C	VN02 036 0005 (1)C
	4,0 mm ²	12	100	VN01 036 0001 (1)C	VN02 036 0001 (1)C
	6,0 mm ²	10	100	VN01 036 0002 (1)C ²⁾	VN02 036 0002 (1)C ²⁾
	10,0 mm ²	8	100	VN01 036 0003 (1)C ²⁾	VN02 036 0003 (1)C ²⁾

Werkzeuge / Tools ³⁾

Bezeichnung / Description	für Leiterquerschnitt for wire gauge	Kontaktaufnahme / Contact locator	Bestell Nr. / Part No.	
			Crimpbacken / Crimping dies	Werkzeuge / Tools
Löswerkzeug für Kontakte Removal tool for contacts	–	–	–	FG 0300 146 3
Löswerkzeug für Module Removal tool for modules	–	–	–	FG 1000 146
Crimpzange für Einzelkontakte Crimping tool for single contacts	1,5 - 2,5 mm ² 4,0 mm ² 6,0 mm ²	TA 0010 146 000 5 TA 0010 146 000 4 TA 0010 146 000 4	TA 0000 144 TA 0000 124 TA 0000 124	TA 0000
4-Kerb Crimpzange ⁴⁾ 4-indet crimping tool ⁴⁾	1,5 - 10,0 mm ²	–	–	TB 0200 146
Crimpzange für Kabelschuhe Crimping tool for cable lugs	6,0 mm ² 10,0 mm ²	–	TA 0000 180	TA 0000
Kabelschuhe für Schutzleiteranschluss / Cable lugs for PE connection			Stückzahl / Pieces	Bestell Nr. / Part No.
Kabelschuh cable lug	6,0 mm ²	–	20	N15 006 000 9Z
	10,0 mm ²	–	20	N15 010 000 7Z

¹⁾ Erläuterung der Bestell-Nr. für die Kontakte siehe Seite 4 / Explanation of the Part No. for contacts see page 4

²⁾ Bei den Leiterquerschnitten 6 + 10 mm² sind Kabelschuhe für den Schutzleiteranschluss zu verwenden / For wire gauges 6 + 10 mm² cable lugs have to be used for PE connection

³⁾ Weitere Informationen siehe Katalog „Werkzeuge“ / Further information see catalogue „Tools“

⁴⁾ incl. Prüfstiftset, Kontaktaufnahme / incl. calibration pin set, locator

Abisolierlängen siehe S. 208 / Stripping length see p. 208

C 146 M
4 pol
4+ 
5 pol

Technische Daten
 Characteristics

Allgemeine Kennwerte	General Characteristics	Norm / Standard	Wert / Value
Polzahl	Number of contacts		4 +  / 5
Anschluss technik	Termination technique		crimpen / crimp
Anschlussquerschnitt	Wire gauge		0,5 - 4,0 mm ² (AWG 20 - 12)
Brennbarkeit	Flammability	UL 94	V-0
Elektrische Kennwerte	Electrical Characteristics		
Bemessungsspannung	Rated voltage	IEC 60664-1	1000 V ¹⁾
Verschmutzungsgrad	Pollution degree	IEC 60664-1	3
Überspannungskategorie	Installation (overvoltage) category	IEC 60664-1	III
Isolierstoffgruppe	Material group	IEC 60664-1	II
Bemessungs-Stoßspannung	Rated impulse withstand voltage	IEC 60664-1	8,0 kV
Spannungsfestigkeit	Voltage proof	IEC 60512-2; Test 4 a	5,7 kV
Strombelastbarkeit	Current carrying capacity	IEC 60512-3; Test 5 b	siehe Derating Kurven / see derating curves
Durchgangswiderstand	Contact resistance	IEC 60512-2; Test 2 a	≤ 5 mΩ
Isolationswiderstand	Insulation resistance	IEC 60512-2; Test 3 a	≥ 10 ¹² Ω
Luftstrecke	Clearance	IEC 60664-1	> 14 mm
Kriechstrecke	Creepage	IEC 60664-1	> 14 mm
Klimatische Kennwerte	Climatical Characteristics		
Prüfklasse	Climatic category	IEC 60068-1	40 / 125 / 21
Obere Grenztemperatur	Upper temperature	IEC 60512-6; Test 11 i	+ 125 °C / 1000 h
Untere Grenztemperatur	Lower temperature	IEC 60512-6; Test 11 i	- 40 °C / 16 h
Mechanische Kennwerte	Mechanical Characteristics		
IP-Schutzart	IP-degree of protection	IEC 60529	20
Steck- und Ziehkraft ²⁾	Insertion and withdrawal forces ²⁾	IEC 60512-7; Test 13 b	15 - 20 N
Mechanische Lebensdauer	Mechanical operation	IEC 60512-5; Test 9 a	≥ 500 Steckzyklen / mating cycles
Werkstoffe	Materials		
Modul	Module		PA 6.6 GF
Farbe	Colour		schwarz / black
Kontakte Stift / Buchse	Contacts male / female		CuZn (Messing/brass) / CuSn (Bronze/bronze)
Kontakt oberfläche	Contact plating		Ag (silber / silver)

¹⁾ 630 V bei Verwendung als Steckvorrichtung / 630 V if the modules are used as plug and socket device

²⁾ für ein Modul / for one module

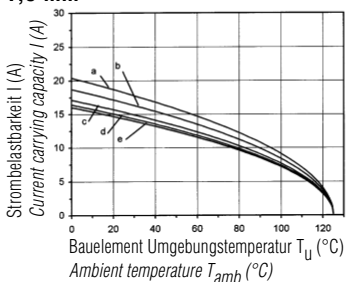
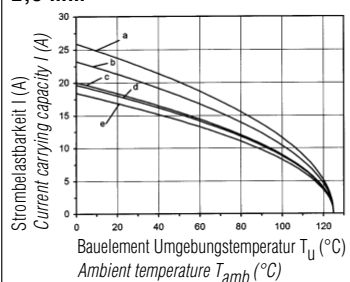
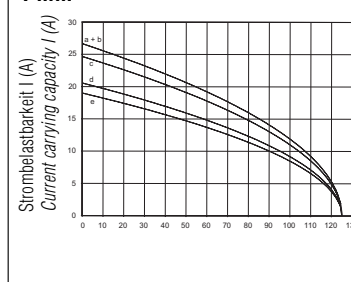
Derating Kurven / Derating curves			Kurve Curve	Polzahl Contacts	Rahmen Frame
1,5 mm² 	2,5 mm² 	4 mm² 	a	5	2 Module
			b	10	2 Module
			c	15	3 Module
			d	25	5 Module
			e	35	7 Module

C 146 M
4 pol
4+ 
5 pol
 Module
 Modules

gestanzte Einzelkontakte
 Stamped single contacts

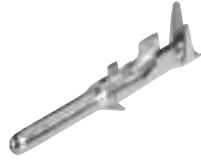

für gestanzte 2,5 mm Kontakte
 for stamped 2,5 mm contacts

Bandkontakte für Crimpzangen
 Contacts on reel for hand crimping tools

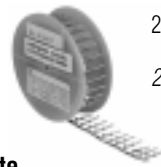

200 / 100 Stück
 200 / 100 pcs

Bandkontakte für Crimpmaschinen
 Contacts on reel for crimp machines

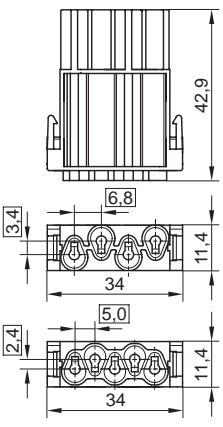
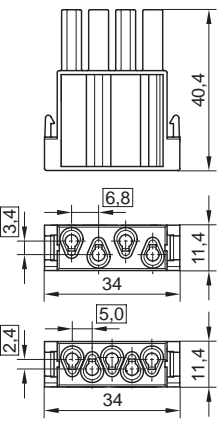

2000 Stück
 (Zuführung links
 oder rechts)
 2000 pcs
 (feeding left or
 right hand side)

Abbildung Figure	Maßzeichnung / Drawing		Bestell Nr. / Part No.	
	Stiftmodul / Pin module	Buchsenmodul / Socket module	Stiftmodul / Pin module	Buchsenmodul / Socket module
			C146 D04 001 E8 (4 pol) C146 D05 001 E8 (4 + PE) C146 D05 801 E8 (5 pol)	C146 C04 001 E8 (4 pol) C146 C05 001 E8 (4 + PE) C146 C05 801 E8 (5 pol)
	PE Kontakt 2 mm voreilend PE contact 2 mm first-to-mate			

Crimpkontakte / Crimp contacts

Lieferform Supplied as	für Leiter- querschnitt for wire gauge	AWG	Stück- zahl Pieces	Bestell Nr. ¹⁾ Stiftkontakt Male contact	Part No. ²⁾ Buchsenkontakt Female contact	Bestell Nr. ¹⁾ Stiftkontakt Male contact	Part No. ²⁾ Buchsenkontakt Female contact
Gestanzte Einzelkontakte / Stamped single contacts							
				versilbert / silver plating		vergoldet / gold plating	
	0,5 - 1,5 mm ²	20 - 16	100	VN01 025 0001 (101)	VN02 025 0001 (101)	VN01 025 0001 (102)	VN02 025 0001 (102)
	1,5 - 2,5 mm ²	16 - 14	100	VN01 025 0010 (101)	VN02 025 0010 (101)	VN01 025 0010 (102)	VN02 025 0010 (102)
	2,5 - 4,0 mm ²	12	100	VN01 025 0043 (1)	VN02 025 0043 (1)		
Bandkontakte für Crimpzangen / Contacts on reel for hand crimping tools							
	0,5 - 1,5 mm ²	20 - 16	200	ZN01 025 0001 (1)	ZN02 025 0001 (1)	ZN01 025 0001 (2)	ZN02 025 0001 (2)
	1,5 - 2,5 mm ²	16 - 14	100	ZN01 025 0010 (1)	ZN02 025 0010 (1)	ZN01 025 0010 (2)	ZN02 025 0010 (2)
Bandkontakte für Crimpmaschinen / Contacts on reel for crimp machines							
Kontaktzuführung rechts Contact feeding right hand side	0,5 - 1,5 mm ²	20 - 16	2000	HN01 025 0001 (1)	HN02 025 0001 (1)		
	1,5 - 2,5 mm ²	16 - 14	2000	HN01 025 0010 (1)	HN02 025 0010 (1)		
Kontaktzuführung links Contact feeding left hand side	0,5 - 1,5 mm ²	20 - 16	2000	TN01 025 0001 (1)	TN02 025 0001 (1)		
	1,5 - 2,5 mm ²	16 - 14	2000	TN01 025 0010 (1)	TN02 025 0010 (1)		
	2,5 - 4 mm ²	12	2000	TN01 025 0043 (1)	TN02 025 0043 (1)		

Werkzeuge / Tools²⁾

Bezeichnung / Description	für Leiterquerschnitt for wire gauge	Bestell Nr. / Part No.		
		Kontaktaufnahme / Contact locator	Crimpbacken / Crimping dies	Werkzeuge / Tools
Lösewerkzeug für Kontakte Removal tool for contacts	–	–	–	FG 0200 146 1
Lösewerkzeug für Module Removal tool for modules	–	–	–	FG 1000 146
Crimpzange für Einzelkontakte Crimping tool for single contacts	0,5 - 1,5 mm ²	TA 0004 146 000 1	TA 0000 163	TA 0000
	1,5 - 2,5 mm ²	TA 0005 146 000 3	TA 0000 141	
	2,5 - 4,0 mm ²	TA 0003 146 000 1	TA 0000 121	

¹⁾ Erläuterung der Bestell-Nr. für die Kontakte siehe Seite 4 / Explanation of the Part No. for contacts see page 4

²⁾ Weitere Informationen siehe Katalog „Werkzeuge“ / Further information see catalogue „Tools“

Abisolierlängen siehe S. 208
 Stripping length see p. 208

C 146 M 3 pol Koax

Technische Daten Characteristics

Allgemeine Kennwerte	General Characteristics	Norm / Standard	Wert / Value
Polzahl	Number of contacts		3
Anschluss technik	Termination technique		crimpen, löten / crimp, solder
Brennbarkeit	Flammability	UL 94	V-0
Elektrische Kennwerte	Electrical Characteristics		
Bemessungsspannung	Rated voltage	IEC 60664-1	250 V
Verschmutzungsgrad	Pollution degree	IEC 60664-1	3
Überspannungskategorie	Installation (overvoltage) category	IEC 60664-1	III
Isolierstoffgruppe	Material group	IEC 60664-1	II
Wellenwiderstand	Impedance		50 Ω
Spannungsfestigkeit	Voltage proof	IEC 60512-2; Test 4 a	0,75 kV
Frequenzbereich	Working frequency		2 GHz
Durchgangswiderstand	Contact resistance	IEC 60512-2; Test 2 a	≤ 6 mΩ
Isolationswiderstand	Insulation resistance	IEC 60512-2; Test 3 a	≥ 10 ⁶ Ω
Klimatische Kennwerte	Climatical Characteristics		
Prüfklasse	Climatic category	IEC 60068-1	40 / 125 / 21
Obere Grenztemperatur	Upper temperature	IEC 60512-6; Test 11 i	+ 125 °C / 1000 h
Untere Grenztemperatur	Lower temperature	IEC 60512-6; Test 11 i	- 40 °C / 16 h
Mechanische Kennwerte	Mechanical Characteristics		
Steck- und Ziehkraft ¹⁾	Insertion and withdrawal forces ¹⁾	IEC 60512-7; Test 13 b	25 - 30 N
Mechanische Lebensdauer	Mechanical operation	IEC 60512-5; Test 9 a	≥ 500 Steckzyklen / mating cycles
Werkstoffe	Materials		
Modul	Module		PA 6.6 GF
Farbe	Colour		rotbraun / redbrown
Kontakt oberfläche	Contact plating		Au (gold / gold)

¹⁾ für ein Modul / for one module

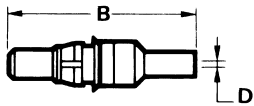
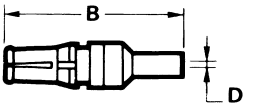
Stiftkontakt / Male contact	Buchsenkontakt / Female contact	Bestell Nr. Part No.	B	D	E	F	G
		17 DM 537 401	23,6	1,7	7,9	6,3	2
		17 DM 537 421	23,6	1,7	7,9	6,3	2
		17 DM 537 405	26,3	3,2	9,5	7,9	2
		17 DM 537 425	26,3	3,2	9,5	7,9	2

Absetzmaße / Stripping Dimensions

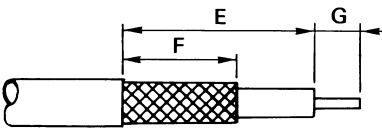

C 146 M 3 pol Koax

Module
Modules

für Koax-Kontakte
for coax-contacts



Abbildung Figure	Maßzeichnung / Drawing		Bestell Nr. / Part No.	
	Stiftmodul / Pin module	Buchsenmodul / Socket module	Stiftmodul / Pin module	Buchsenmodul / Socket module
			C146 A03 501 E8	C146 B03 501 E8

Crimpkontakte ¹⁾ / Crimp contacts ¹⁾

Lieferform Supplied as	für Kabelgröße for cable size	Stückzahl Pieces	Bestell Nr. / Part No.	
			Stiftkontakt / Male contact	Buchsenkontakt / Female contact
Einzelkontakte / Single contacts				
	RG 174, 179, 316	1	17 DM 537 401	17 DM 537 421
	RG 58	1	17 DM 537 405	17 DM 537 425

Werkzeuge ²⁾ / Tools ²⁾

Bezeichnung / Description	für Kabelgröße for cable size	6-Kant-Maß in mm 6-hex-size in mm			Bestell Nr. / Part No.	
					Crimpbacken / Crimping dies	Werkzeuge / Tools
Lösewerkzeug für Kontakte Removal tool for contacts	–	–	–	–	–	FG 0300 146 3
Lösewerkzeug für Module Removal tool for modules	–	–	–	–	–	FG 1000 146
Crimpzange für Einzelkontakte Crimping tool for single contacts	RG 58	5,4	(6,5)	(1,7)	TA 0000 401	TA 0000
	RG 174, 179, 316	3,25	(4,5)	(1,7)	TA 0000 402	TA 0000

¹⁾ Weitere Kontakte auf Anfrage / Further contacts on request

²⁾ Weitere Informationen siehe Katalog „Werkzeuge“ / Further information see catalogue „Tools“

C 146 M 3 pol

Technische Daten Characteristics

M

Allgemeine Kennwerte	General Characteristics	Norm / Standard	Wert / Value
Polzahl	Number of contacts		3
Anschluss technik	Termination technique		crimpen / crimp
Anschlussquerschnitt	Wire gauge		1,5 - 10 mm ² (AWG 16 - 8)
Brennbarkeit	Flammability	UL 94	V-0
Elektrische Kennwerte	Electrical Characteristics		
Bemessungsspannung	Rated voltage	IEC 60664-1	1000 V ¹⁾
Verschmutzungsgrad	Pollution degree	IEC 60664-1	3
Überspannungskategorie	Installation (overvoltage) category	IEC 60664-1	III
Isolierstoffgruppe	Material group	IEC 60664-1	II
Bemessungs-Stoßspannung	Rated impulse withstand voltage	IEC 60664-1	8,0 kV
Spannungsfestigkeit	Voltage proof	IEC 60512-2; Test 4 a	5,7 kV
Strombelastbarkeit	Current carrying capacity	IEC 60512-3; Test 5 b	siehe Derating Kurven / see derating curves
Durchgangswiderstand	Contact resistance	IEC 60512-2; Test 2 a	≤ 1 mΩ
Isolationswiderstand	Insulation resistance	IEC 60512-2; Test 3 a	≥ 10 ¹² Ω
Luftstrecke	Clearance	IEC 60664-1	> 14 mm
Kriechstrecke	Creepage	IEC 60664-1	> 14 mm
Klimatische Kennwerte	Climatical Characteristics		
Prüfklasse	Climatic category	IEC 60068-1	40 / 125 / 21
Obere Grenztemperatur	Upper temperature	IEC 60512-6; Test 11 i	+ 125 °C / 1000 h
Untere Grenztemperatur	Lower temperature	IEC 60512-6; Test 11 i	- 40 °C / 16 h
Mechanische Kennwerte	Mechanical Characteristics		
IP-Schutzart	IP-degree of protection	IEC 60529	20
Steck- und Ziehkraft ²⁾	Insertion and withdrawal forces ²⁾	IEC 60512-7; Test 13 b	20 - 30 N
Mechanische Lebensdauer	Mechanical operation	IEC 60512-5; Test 9 a	≥ 500 Steckzyklen / mating cycles
Werkstoffe	Materials		
Modul	Module		PA 6.6 GF
Farbe	Colour		schwarz / black
Kontakte	Contacts		Cu-Legierung / Cu-alloy
Kontaktoberfläche	Contact plating		Ag (silber / silver)

¹⁾ 630 V bei Verwendung als Steckvorrichtung / 630 V if the modules are used as plug and socket device

²⁾ für ein Modul / for one module

Derating Kurven / Derating curves

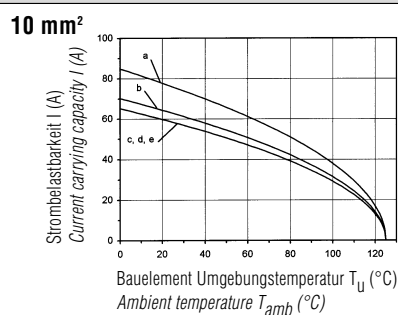
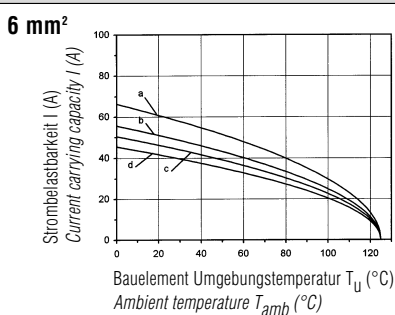

Kurve Curve	Polzahl Contacts	Rahmen Frame
a	3	2 Module
b	6	2 Module
c	9	3 Module
d	15	5 Module
e	21	7 Module

C 146 M 3 pol

Module
Modules



für gedrehte 3,6 mm Kontakte
for turned 3,6 mm contacts

alle Kontakte 2 mm voreilend zu anderen Modulen
all contacts 2 mm first-to-mate to other modules

Abbildung Figure	Maßzeichnung / Drawing		Bestell Nr. / Part No.	
	Stiftmodul / Pin module	Buchsenmodul / Socket module	Stiftmodul / Pin module	Buchsenmodul / Socket module
			C146 A03 801 E8	C146 B03 801 E8

Crimpkontakte / Crimp contacts

Lieferform Supplied as	für Leiterquerschnitt for wire gauge	AWG	Stückzahl Pieces	Bestell Nr. ¹⁾ / Part No. ¹⁾	
				Stiftkontakt / Male contact	Buchsenkontakt / Female contact
Crimpkontakte / Crimp contacts					
Einzelkontakt Single contact	1,5 mm ²	16	100	VN01 036 0004 (1)C	VN02 036 0004 (1)C
	2,5 mm ²	14	100	VN01 036 0005 (1)C	VN02 036 0005 (1)C
	4,0 mm ²	12	100	VN01 036 0001 (1)C	VN02 036 0001 (1)C
	6,0 mm ²	10	100	VN01 036 0002 (1)C ²⁾	VN02 036 0002 (1)C ²⁾
	10,0 mm ²	8	100	VN01 036 0003 (1)C ²⁾	VN02 036 0003 (1)C ²⁾

Werkzeuge / Tools ³⁾

Bezeichnung / Description	für Leiterquerschnitt for wire gauge	Kontaktaufnahme / Contact locator	Bestell Nr. / Part No.	
			Crimpbacken / Crimping dies	Werkzeuge / Tools
Lösewerkzeug für Kontakte Removal tool for contacts	–	–	–	FG 0300 146 3
Lösewerkzeug für Module Removal tool for modules	–	–	–	FG 1000 146
Crimpzange für Einzelkontakte Crimping tool for single contacts	1,5 - 2,5 mm ² 4,0 mm ² 6,0 mm ²	TA 0010 146 000 2 TA 0010 146 000 4 TA 0010 146 000 4	TA 0000 144 TA 0000 124 TA 0000 124	TA 0000
4-Kerb Crimpzange ⁴⁾ 4-indet crimping tool ⁴⁾	1,5 - 10,0 mm ²	–	–	TB 0200 146
Crimpzange für Kabelschuhe Crimping tool for cable lugs	6,0 mm ² 10,0 mm ²	–	TA 0000 180	TA 0000
Kabelschuhe für Schutzleiteranschluss / Cable lugs for PE connection				Bestell Nr. / Part No.
Kabelschuh cable lug	6,0 mm ²	–	20	N15 006 000 9Z
	10,0 mm ²	–	20	N15 010 000 7Z

¹⁾ Erläuterung der Bestell-Nr. für die Kontakte siehe Seite 4 / Explanation of the Part No. for contacts see page 4

²⁾ Bei den Leiterquerschnitten 6 + 10 mm² sind Kabelschuhe für den Schutzleiteranschluss zu verwenden / For wire gauges 6 + 10 mm² cable lugs have to be used for PE connection

³⁾ Weitere Informationen siehe Katalog „Werkzeuge“ / Further information see catalogue „Tools“

⁴⁾ incl. Prüfstiftset, Kontaktaufnahme / incl. calibration pin set, locator

C 146 M
RJ Modul
RJ module

Technische Daten
Characteristics

Allgemeine Kennwerte	General Characteristics	Norm / Standard	Wert / Value Module	Wert / Value RJ45
Polzahl	<i>Number of contacts</i>		4	8
Anschluss technik	<i>Termination technique</i>		Crimpen	Stecken
Anschlussquerschnitt	<i>Wire gauge</i>		0,14 - 2,5mm ²	
Brennbarkeit	<i>Flammability</i>	UL 94	V - 0	V - 0
Elektrische Kennwerte	Technical Characteristics			
Bemessungsspannung	<i>Rated voltage</i>	IEC 60664-1	400 V AC	125 V AC
Bemessungs-Stoßspannung	<i>Rated impulse withstand voltage</i>	IEC 60664-1	6 kV	1,8 kV
Spannungsfestigkeit	<i>Voltage proof</i>	IEC 60512-2; Test 4 a	3,51 kV	1,0 kV
Strombelastbarkeit	<i>Current carrying capacity</i>	IEC 60512-3; Test 5 b	13 A ¹⁾	1,5 A
Durchgangswiderstand	<i>Contact resistance</i>	IEC 60512-2; Test 2 a	≤ 5 mΩ	≤ 20 mΩ
Isolationswiderstand	<i>Insulation resistance</i>	IEC 60512-2; Test 3 a	10 ¹⁰ Ω	5 ⁹ Ω
Klimatische Kennwerte	Climatical Characteristics			
Obere Grenztemperatur	<i>Upper temperature</i>	IEC 60512-6; Test 11 i	+ 100 °C / 1000 h	+ 80 °C / 1000 h
Untere Grenztemperatur	<i>Lower temperature</i>	IEC 60512-6; Test 11 i		- 20 °C / 16 h
Mechanische Kennwerte	Mechanical Characteristics			
Steck- und Ziehkraft	<i>Insertion and withdrawal forces</i>	IEC 60512-7; Test 13 b	15-20 N	max. 20 N
Mechanische Lebensdauer	<i>Mechanical operation</i>	IEC 60512-5; Test 9 a	≥ 500 Steckzyklen <i>mating cycles</i>	≥ 500 Steckzyklen <i>mating cycles</i>
Werkstoffe	Materials			
Kontakteinsatz	<i>Insert</i>		PA 6.6 GF	
Farbe	<i>Colour</i>		schwarz / <i>black</i>	schwarz / <i>black</i>
Kontakte Stift / Buchse	<i>Contacts male / female</i>		CuZn	CuSn
Kontaktoberfläche	<i>Contacts plating</i>		Ag (silber / <i>silver</i>)	Au (Gold / <i>gold</i>)

1) 2 Module, 40°C Umgebungstemperatur, 1,5 mm² Anschlussquerschnitt / 2 Modules, 40°C ambient temperature, 1,5 mm² wire gauge

RJ Modul

Zur Integration von Standard RJ45 Komponenten

- Weltweiter Echtzeit-Zugriff auf Maschinen und Anlagen
- Sehr leichte Konfektionierung durch Einsatz von Standard RJ45 Komponenten
- Ein Steckverbinder für Power, Signale und Datenübertragung
- Zusätzlich 4 Power Crimp-Kontakte
- Zeit- und Kosteneinsparungen durch einheitliche Aktiv- und Passivkomponenten
- Einheitliches Übertragungsprotokoll im Office- und Produktionsbereich
- erreicht CAT 5 für Ethernet nach ISO/IEC 11801

Rahmen für die Integration des RJ45 Moduls sowie Gehäuse für den Einbau der Rahmen entnehmen Sie bitte dem Gesamtkatalog C146 Schwere Steckverbinder

RJ Module





For integration of standard RJ45 components

- Worldwide real-time access on machines and facilities
- Easy assembly through the use of standard RJ45 components
- One connector for power, signal and data transmission
- 4 additional power crimp contacts
- Time- and money saving through the use of similar active- and passive components
- Unitary transmission protocol in the office- and production environment.
- Meets CAT 5 for Ethernet acc. ISO/IEC 11801

Frames for the integration of the RJ45 module as well as housings for the incorporation of the frames can be found in the full range C146 heavy connectors catalogue

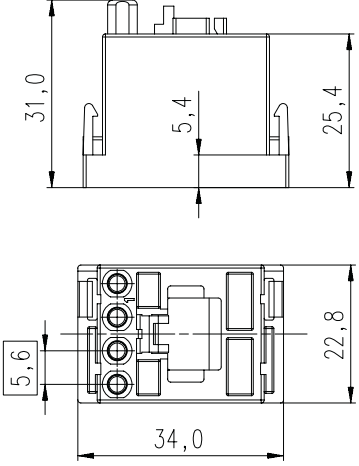
C 146 M
RJ Modul
RJ module

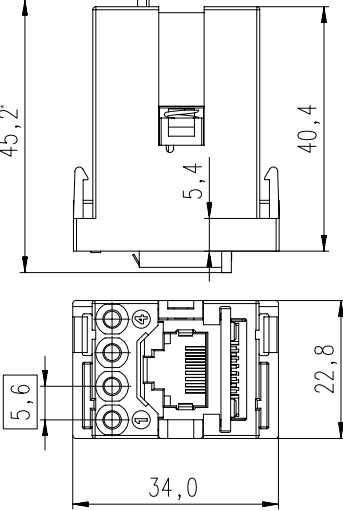
Module
Modules

Abbildung <i>Figure</i>	Maßzeichnung <i>Drawing</i>	Bestell Nr. <i>Part No.</i>
<p>Stiftmodul / <i>Pin module</i></p> 		<p>C146 E12 001 E8</p>
<p>Buchsenmodul / <i>Socket module</i></p> 		<p>C146 F12 001 G8</p>
<p>Tüllengehäuse, 2x Abgang oben / <i>Hood, 2x top entry</i></p> 	<p>10 pol 2xM25 ohne Stutzen / <i>without stud</i> 16 pol 2xM25 ohne Stutzen / <i>without stud</i> 24 pol 1xM25 + 1xM40 ohne Stutzen / <i>without stud</i></p>	<p>C146 21R010 902 8 C146 21R016 910 8 C146 21R024 913 8</p>
<p>Kabelverschraubung, geteilt (Verpackungseinheit 5 St.) <i>Gland bushing, splitted (packing unit 5 pcs.)</i></p> 		<p>VN16 250 0131 V</p>

*Wenn Buchse eingefedert: 46,8 / *If plug socket recessed: 46,8*

C 146 M

Pneu Modul

Pneumatic module

Technische Daten *Characteristics*

Allgemeine Kennwerte	General Characteristics	Norm / Standard	Wert / Value
Kontaktzahl	Number of contacts		1 / 2
Anschlussstechnik	Termination technique		Schlauchanschluss / tube termination
Anschlussquerschnitt	Wire gauge		2,5 mm / 4,0 mm
Brennbarkeit	Flammability	UL 94	V-0
Technische Kennwerte	Technical Characteristics		
Betriebsdruck	Operating pressure		8 bar mit PTFE-Schlauch (Teflon) / with PTFE tube
Schaltweg	Operating path		4,0 mm
Absperrung	Locking		einseitig absperrend / locking on one side
Pneumatikschlauch	Pneumatic tube		nur PTFE-Schläuche verwenden ¹⁾ only use PTFE tubes ¹⁾
Klimatische Kennwerte	Climatical Characteristics		
Obere Grenztemperatur	Upper temperature		+100 °C
Untere Grenztemperatur	Lower temperature		- 20 °C
Mechanische Kennwerte	Mechanical Characteristics		
Mechanische Lebensdauer	Mechanical operation		5000 Steckzyklen / mating cycles
Werkstoffe	Materials		
Modul	Module		PA 6.6 GF
Farbe	Colour		schwarz / black
Kontakte	Contacts		Messing MS 58 / Brass MS 58

¹⁾ Die Module sind speziell für den Einsatz von PTFE-Schläuchen konzipiert und dürfen nur in Verbindung mit diesen eingesetzt werden. Der Einsatz von Schläuchen aus anderem Material ist nicht zu empfehlen, da die oberen und unteren Grenztemperaturen nicht erreicht werden.

¹⁾ The modules are specifically designed for the use of PTFE tubes and should only be used in conjunction with these. The use of tubes made from other materials is not recommended, as the higher and lower category temperatures will not be achievable.

Pneu Modul

Leistung, Signal und Pneumatik in einem Steckverbinder

- Sehr stabile Messing-Kontakte
- Pneumatik-Buchsenkontakte mit Absperrung, schließt bei geöffnetem Steckverbinder
- Wahlweise mit 1 oder 2 Anschlüssen
- Anschluss für 2,5 mm oder 4 mm PTFE (Teflon)-Schläuchen
- Schläuche können von den Anschlüssen wieder demontiert werden

Rahmen für die Integration des Pneu Moduls sowie Gehäuse für den Einbau der Rahmen entnehmen Sie bitte dem Gesamtkatalog C146 Schwere Steckverbinder.

Pneumatic Module



Power, signal and pneumatic within a single connector

- Very stable brass contacts
- Pneumatic socket contacts with barrier, closes when the connector is open
- Available with single or double connections
- Connection for 2.5 mm or 4 mm PTFE (Teflon)-tubes
- Tubes can be disassembled from the terminations

Frames for the integration of the pneumatic module as well as housings for the incorporation of the frames can be found in the full range C146 heavy connectors catalogue.

C 146 M
Pneu Modul
Pneumatic module

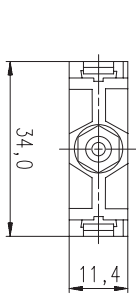
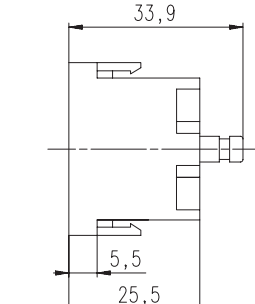

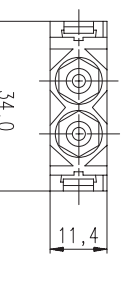
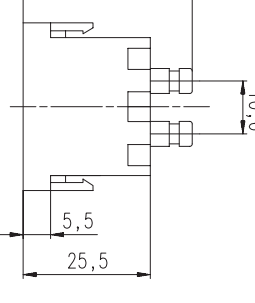







Module
Modules

Abbildung Figure	Maßzeichnung / Drawing		Bestell Nr. / Part No.	
	Stiftmodul / Pin module	Buchsenmodul / Socket module	Stiftmodul / Pin module	Buchsenmodul / Socket module
			C146 G01 014 G8 (2,5 mm) C146 G01 024 G8 (4,0 mm)	C146 H01 034 G8 (2,5 mm) C146 H01 044 G8 (4,0 mm)
			C146 G02 014 G8 (2,5 mm) C146 G02 024 G8 (4,0 mm)	C146 H02 034 G8 (2,5 mm) C146 H02 044 G8 (4,0 mm)

M

C 146 M



Löswerkzeuge, Zubehör
Removal tools, accessories

Kontaktgröße Contact size	Abbildung Figure	Bestell Nr. Part No.
1,0 mm		17D 438 SP
1,6 mm		FG 0300 146 1
2,5 mm gedreht 2,5 mm turned		FG 0300 146 4
2,5 mm gestanzt 2,5 mm stamped		FG 0200 146 1
3,6 mm		FG 0300 146 3
Modullösewerkzeug Removal tool for modules		FG 1000 146
Blind Module Blank modules		C146 A00 001 E8 (Stift/pin) C146 B00 001 E8 (Buchse/socket)
Modulkoppler Module coupler		C146 10Z000 002 8
Montagewinkel Assembly angle		C146 10Z001 001 8
Zugentlastung Strain relief		C146 10Z002 001 8

C 146 A



A

Hauptmerkmale		Main characteristics	
<ul style="list-style-type: none"> • Schmale Bauform • Bemessungsspannung 250 / 400 V • Bemessungsstrom 14 A ... 18 A • Anschlussart: schrauben • Polzahl: 3, 4, 10, 16, 32 		<ul style="list-style-type: none"> • Narrow style • Rated voltage 250 / 400 V • Rated current 14 A ... 18 A • Termination: screw • Number of contacts: 3, 4, 10, 16, 32 	
Zulassungen / Approvals	Prüfstelle / Testhouse	Kennwerte / Characteristics	Zulassungs-Nummer / Approval-No.
SEV		250 V, 10 A	
UL		600 V, 14 A	E 63093
CSA		600 V, 10 A; 16 A; 20 A	LR 700721
<p>Zulassungen beziehen sich im allgemeinen auf repräsentative Ausführungen der Steckverbinderserie. Prüfumfang und Prüfvorschrift auf Anfrage.</p>		<p><i>In general approvals refer to representative versions of the connector series. Extent and specification of tests upon request.</i></p>	

C 146 A

Kurzinformation Brief information

Allgemeine Hinweise



General information

- Steckverbinder der Serie C 146 A dürfen unter Spannung, jedoch nicht unter Strom betätigt werden. Werden die Steckverbinder als Steckvorrichtung eingesetzt, ist der Strom auf 10 % des Bemessungsstroms zu begrenzen.
- Für die Einsätze der Serie C 146 A (10 + 16 pol) können sowohl niedrige, wie auch hohe Gehäusebauformen verwendet werden.
- *For series C 146 A connectors may be engaged or disengaged when live but without electrical load. If these connectors are used as plug and socket device, the load shall be reduced to 10 % of the rated current.*
- *Low and high profile housing for C 146 A series inserts for 10 and 16 contacts.*

Nicht genormte Steckverbinder, aber:

No standard for this series, but:

- Steck- und austauschbar mit Fremdfabrikaten
a) Kontakteinsatz / Kontakteinsatz
b) Kontakteinsatz / Gehäuse 10, 16 pol.
- *Interchangeable with other makes
a) contact insert to contact insert
b) contact insert to housing 10, 16 pin*

Gehäuse nach CECC 75 301 - 801

Housings are designed according to CECC 75 301 - 801

Voreilender Schutzkontakt

First-to-mate last-to-break protective ground contact

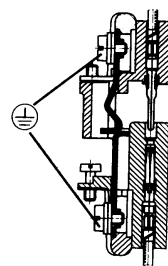

Große Gehäuseauswahl in 2 Bauhöhen (ab Seite 116)

Large range of housings in 2 different heights (see page 116)



Allgemeine Kennwerte	General Characteristics	Norm / Standard	Wert / Value			
Polzahl	Number of contacts		3/4 + ⊕	10 + ⊕	16 + ⊕	32 + ⊕
Anschluss technik	Termination technique		schrauben / screw			
Anschlussquerschnitt	Wire gauge		0,25 - 2,5 mm ²			
Brennbarkeit	Flammability	UL 94	V-0			
Elektrische Kennwerte	Electrical Characteristics					
Bemessungsspannung	Rated voltage	IEC 60664-1	400 V	250 V		
Verschmutzungsgrad	Pollution degree	IEC 60664-1	3			
Überspannungskategorie	Installation (overvoltage) category	IEC 60664-1	III			
Isolierstoffgruppe	Material group	IEC 60664-1	III b			
Bemessungs-Stoßspannung	Rated impulse withstand voltage	IEC 60664-1	4,0 kV			
Spannungsfestigkeit	Voltage proof	IEC 60512-2; Test 4 a	2,8 kV			
Strombelastbarkeit	Current carrying capacity	IEC 60512-3; Test 5 b	siehe Derating Kurven / see derating curves			
Bemessungsstrom T _U = 40 °C	Rated current T _{amp} = 40 °C		18 A	16 A	14 A	14 A
Durchgangswiderstand	Contact resistance	IEC 60512-2; Test 2 a	≤ 5 m Ω			
Isolationswiderstand	Insulation resistance	IEC 60512-2; Test 3 a	≥ 10 ¹² Ω ¹⁾			
Klimatische Kennwerte	Climatical Characteristics					
Prüfklasse	Climatic category	IEC 60068-1	40 / 100 / 21			
Obere Grenztemperatur	Upper temperature	IEC 60512-6; Test 11 i	+ 100 °C / 1000 h			
Untere Grenztemperatur	Lower temperature	IEC 60512-6; Test 11 i	- 40 °C / 16 h			
Mechanische Kennwerte	Mechanical Characteristics					
Steck- und Ziehkraft	Insertion and withdrawal forces	IEC 60512-7; Test 13 b	15 - 20 N	50 - 70 N	80-100 N	160-200 N
²⁾ IP-Schutzart Stifteinsatz	IP-degree of protection pin insert	IEC 60529	ungesteckt/unmated IP00		gesteckt/mated IP20	
²⁾ IP-Schutzart Buchseneinsatz	IP-degree of protection socket insert	IEC 60529	ungesteckt/unmated IP20		gesteckt/mated IP20	
Gewicht Stifteinsatz	Weight pin insert		13 g	48 g	68 g	136 g
Gewicht Buchseneinsatz	Weight socket insert		13 g	52 g	73 g	146 g
Mechanische Lebensdauer	Mechanical operation	IEC 60512-5; Test 9 a	≥ 500 Steckzyklen / mating cycles			
Werkstoffe	Materials					
Kontakteinsatz	Insert		PA	PBT	PBT	PBT
Kontakte	Contacts		Cu Zn (Messing / brass)			
Kontakt oberfläche	Contact plating		Ag (silber / silver)			

¹⁾ Bei Beanspruchung > 10¹⁰ Ω / Under operating conditions > 10¹⁰ Ω







²⁾ IP-Schutzart im Anschlussbereich der Schraubausführung IP 10 / IP-degree of protection on termination side of screw version IP 10

C 146 A
3/4 + 

400 V~ **10 A**

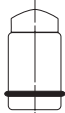
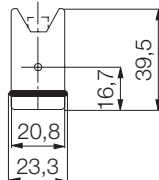
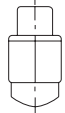
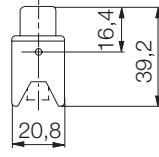
Steckverbinder
Connectors

Gehäuse siehe Seite 116-119
Housings see page 116-119

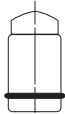
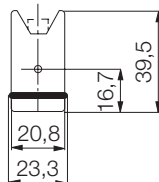
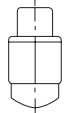
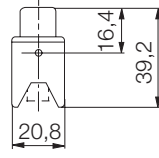
Bezeichnung - Abbildung Description - Figure	Maßzeichnung Drawing	Bestell Nr. / Part No.	
		Stifteinsatz / Male insert	Buchseinsatz / Female insert
Kontakteinsatz Schraubanschluss 3 +  <i>Contact insert screw termination</i> 3 +  	Stifteinsatz <i>Male insert</i>  M  Buchseinsatz <i>Female insert</i>  F 	C146 10A003 002 4	C146 10B003 002 4
Kontakteinsatz Schraubanschluss 4 +  <i>Contact insert screw termination</i> 4 +   nur für Kunststoffgehäuse only for thermoplastic housings	Stifteinsatz <i>Male insert</i>  M  Buchseinsatz <i>Female insert</i>  F 	C146 10A004 002 4	C146 10B004 002 4

Steckbild / pin layout

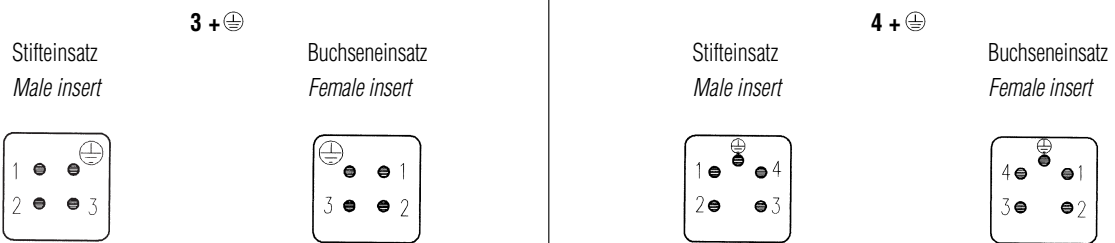

Derating Kurven / Derating curves

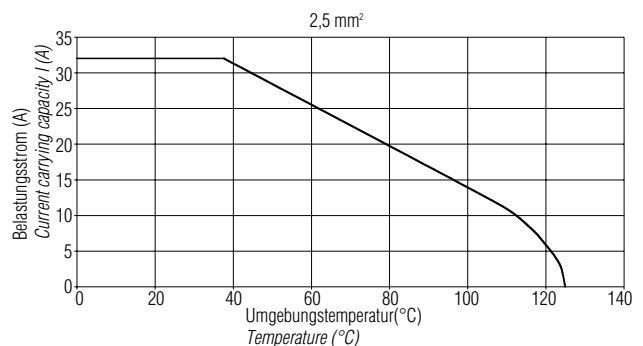
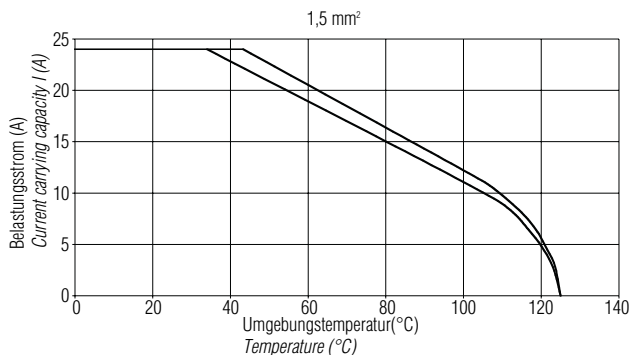

C 146 A
10 + 

250 V~ 16 A

Steckverbinder
 Connectors

Gehäuse siehe Seite 120-123
 Housings see page 120-123

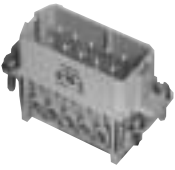
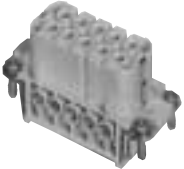
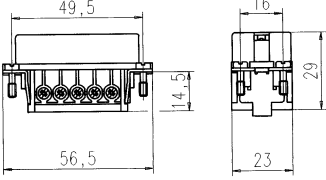
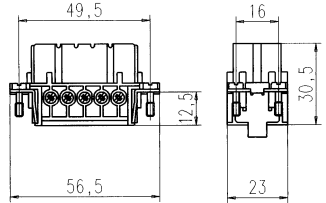
Bezeichnung - Abbildung Description - Figure	Maßzeichnung Drawing	Bestell Nr. / Part No.	
		Stifteinsatz / Male insert	Buchseinsatz / Female insert
Kontakteinsatz Schraubanschluss Contact insert screw termination  	Stifteinsatz Male insert 	C146 10A010 002 4 C146 10A010 102 4 (mit Drahtschutz / with wire protection)	C146 10B010 002 4 C146 10B010 102 4 (mit Drahtschutz / with wire protection)
	Buchseinsatz Female insert 		

Montageanleitung, Steckbild / Assembly instruction, pin layout

Stifteinsatz
 Male insert

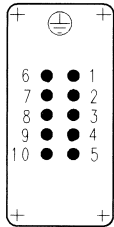

Buchseinsatz
 Female insert

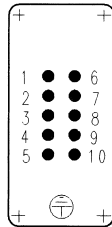

Montageausschnitt (Kontaktträger)
 Panel cut out (insert)

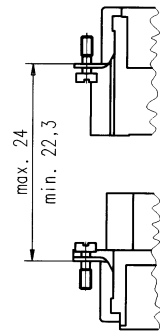
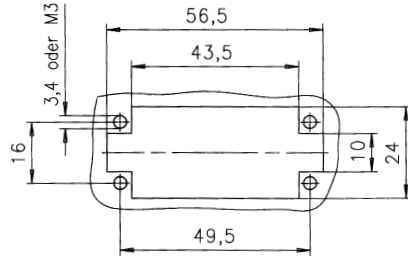

Derating Kurven / Derating curves

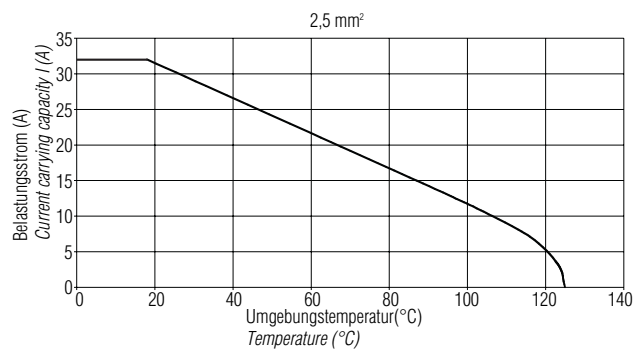
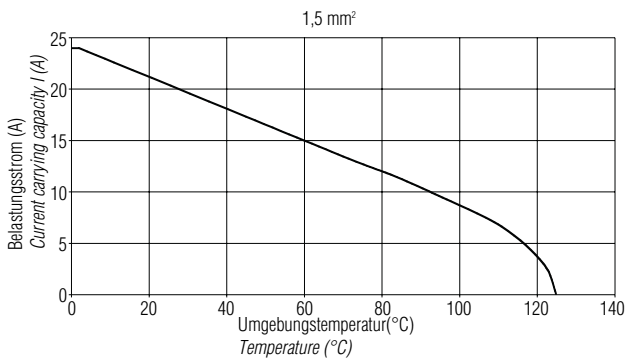

C 146 A
16 + 

250 V~ 14 A

Steckverbinder
 Connectors

Gehäuse siehe Seite 124–127
 Housings see page 124–127

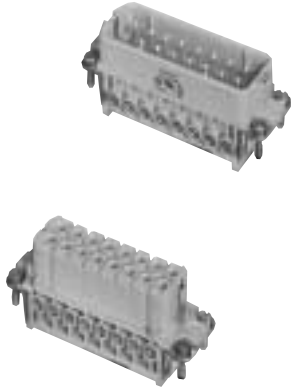
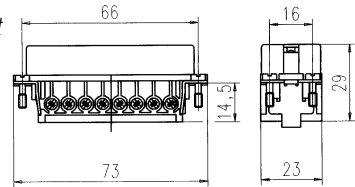
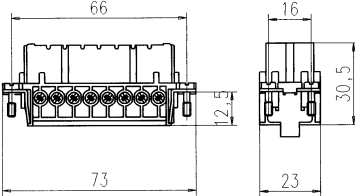
Bezeichnung - Abbildung Description - Figure	Maßzeichnung Drawing	Bestell Nr. / Part No.	
		Stifteinsatz / Male insert	Buchseinsatz / Female insert
Kontakteinsatz Schraubanschluss Contact insert screw termination 	Stifteinsatz Male insert  Buchseinsatz Female insert 	C146 10A016 002 4 C146 10A016 102 4 (mit Drahtschutz / with wire protection)	C146 10B016 002 4 C146 10B016 102 4 (mit Drahtschutz / with wire protection)

Montageanleitung, Steckbild / Assembly instruction, pin layout

Stifteinsatz
 Male insert

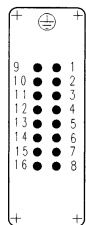

Buchseinsatz
 Female insert

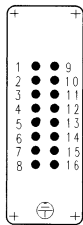

Montageausschnitt (Kontaktträger)
 Panel cut out (insert)

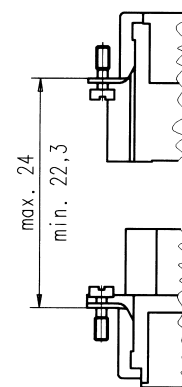
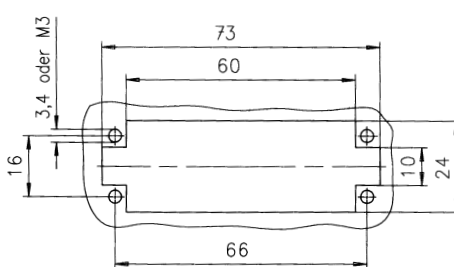

Derating Kurven / Derating curves

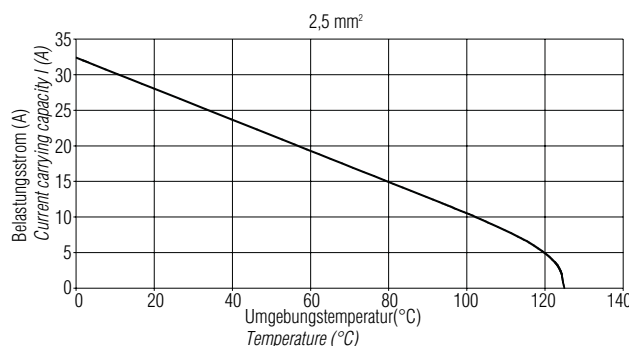
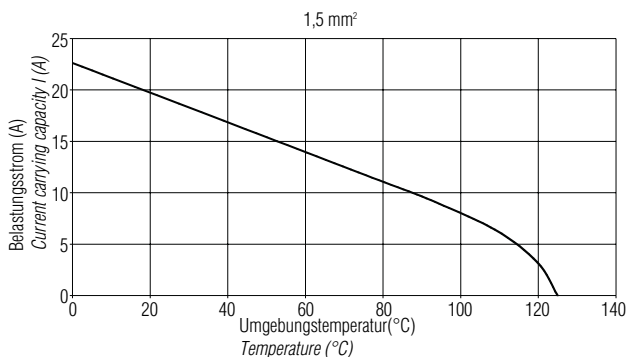

C 146 A
32 + 

250 V~ 14 A

Steckverbinder
Connectors

Gehäuse siehe Seite 128–131
Housings see page 128–131

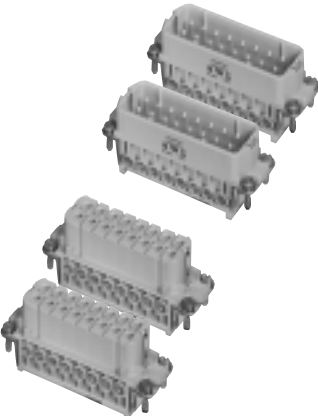
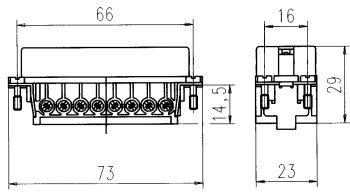
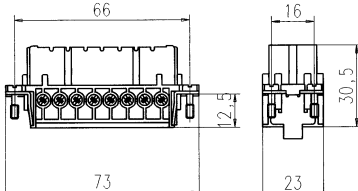
Bezeichnung - Abbildung Description - Figure	Maßzeichnung Drawing	Bestell Nr. / Part No.	
		Stifteinsatz / Male insert	Buchseinsatz / Female insert
Kontakteinsatz Schraubanschluss Contact insert screw termination 	Stifteinsatz Male insert  Buchseinsatz Female insert 	C146 10A016 002 4 (1 - 16) + C146 10A016 004 4 (17 - 32)	C146 10B016 002 4 (1 - 16) + C146 10B016 004 4 (17 - 32)
		C146 10A016 102 4 (1 - 16) + C146 10A016 104 4 (17 - 32) (mit Drahtschutz / with wire protection)	C146 10B016 102 4 (1 - 16) + C146 10B016 104 4 (17 - 32) (mit Drahtschutz / with wire protection)

Montageanleitung, Steckbild / Assembly instruction, pin layout

Stifteinsatz
Male insert

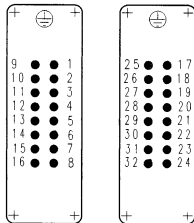

Buchseinsatz
Female insert

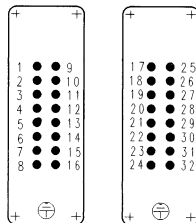

Montageausschnitt (Kontaktträger)
Panel cut out (insert)

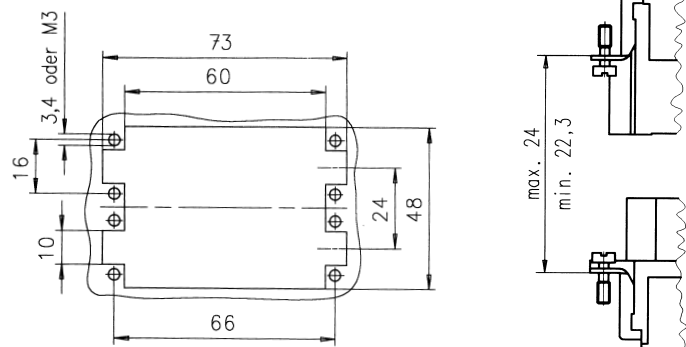



A

C 146 HSE



HSE

Hauptmerkmale		Main characteristics	
<ul style="list-style-type: none"> • Bemessungsspannung 400 V • Bemessungsstrom 42 A • Anschlussart: schrauben • Anschlussquerschnitt: 6mm² • Polzahl: 6 		<ul style="list-style-type: none"> • Rated voltage 400 V • Rated current 42 A • Termination: screw • Max. wire gauge 6 mm² • Number of contacts: 6 	
Zulassungen / Approvals Prüfstelle / Testhouse		Kennwerte / Characteristics	Zulassungs-Nummer / Approval-No.
UL		600 V, 35 A	48932
CSA		600 V, 35 A	E 63093
<p>Zulassungen beziehen sich im allgemeinen auf repräsentative Ausführungen der Steckverbinderserie. Prüfumfang und Prüfvorschrift auf Anfrage.</p>		<p><i>In general approvals refer to representative versions of the connector series. Extent and specification of tests upon request.</i></p>	

Allgemeine Kennwerte	General Characteristics	Norm / Standard	Wert / Value
Polzahl	Number of contacts		6 + ⊕
Anschluss technik	Termination technique		schrauben / screw
Anschlussquerschnitt	Wire gauge		0,5 - 6,0 mm ² (Ø 3,4 mm)
Brennbarkeit	Flammability	UL 94	V-0
Elektrische Kennwerte	Electrical Characteristics		
Bemessungsspannung	Rated voltage	IEC 60664-1	400 V (600 V UL / CSA ²)
Verschmutzungsgrad	Pollution degree	IEC 60664-1	3
Überspannungskategorie	Installation (overvoltage) category	IEC 60664-1	III
Isolierstoffgruppe	Material group	IEC 60664-1	II
Bemessungs-Stoßspannung	Rated impulse withstand voltage	IEC 60664-1	6,0 kV
Spannungsfestigkeit	Voltage proof	IEC 60512-2; Test 4 a	2200 V
Strombelastbarkeit	Rated current	IEC 60512-3; Test 5 b	siehe Derating Kurven / see derating curves
Bemessungsstrom T _U = 40 °C	Rated current T _{amp} = 40 °C		42 A
Durchgangswiderstand	Contact resistance	IEC 60512-2; Test 2 a	≤ 1 m Ω
Isolationswiderstand	Insulation resistance	IEC 60512-2; Test 3 a	≥ 10 ¹² Ω ¹⁾
Luftstrecke	Clearance	IEC 60664-1	≥ 3,5 mm
Kriechstrecke	Creepage	IEC 60664-1	≥ 5,6 mm
Klimatische Kennwerte	Climatical Characteristics		
Prüfklasse	Climatic category	IEC 60068-1	40 / 125 / 21
Obere Grenztemperatur	Upper temperature	IEC 60512-6; Test 11 i	+ 125 °C / 1000 h
Untere Grenztemperatur	Lower temperature	IEC 60512-6; Test 11 i	- 40 °C / 16 h
Mechanische Kennwerte	Mechanical Characteristics		
Steck- und Ziehkraft	Insertion and withdrawal forces	IEC 60512-7; Test 13 b	40 - 60 N
³⁾ IP-Schutzart Stifteinsatz	IP-degree of protection pin insert	IEC 60529	ungesteckt/unmated IP00
³⁾ IP-Schutzart Buchseneinsatz	IP-degree of protection socket insert	IEC 60529	ungesteckt/unmated IP20
Gewicht Stifteinsatz	Weight pin insert		80 g
Gewicht Buchseneinsatz	Weight socket insert		80 g
Mechanische Lebensdauer	Mechanical operation	IEC 60512-5; Test 9 a	≥ 500 Steckzyklen / mating cycles
Werkstoffe	Materials		
Kontakteinsatz	Insert		PA, GV
Kontakte	Contacts		Cu Zn (Messing / brass)
Kontaktoberfläche	Contact plating		Ag (silber / silver)
Farbe	Colour		schwarz / black

¹⁾ Bei Beanspruchung > 10¹⁰ Ω / Under operating conditions > 10¹⁰ Ω

²⁾ Hinweisschild für CSA-Anwendung siehe Seite 186/ Label for CSA application see page 186

³⁾ IP-Schutzart im Anschlussbereich IP 10 / IP-degree of protection on termination side IP 10

C 146 HSE

6 + 

400 V~

42 A

Steckverbinder
Connectors

Gehäuse siehe Seite 144–151
Housings see page 144–151

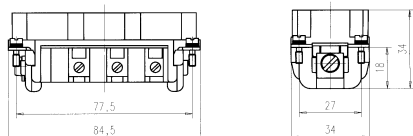
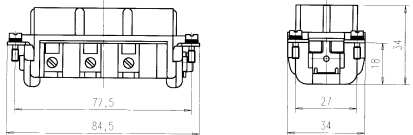
Bezeichnung - Abbildung Description - Figure	Maßzeichnung Drawing	Bestell Nr. / Part No.	
		Stifteinsatz / Male insert	Buchseinsatz / Female insert
Kontakteinsatz Schraubanschluss Contact insert screw termination	<p>Stifteinsatz Male insert</p>  <p>Buchseinsatz Female insert</p> 	C146 10A006 102 5 (mit Drahtschutz / with wire protection)	C146 10B006 102 5 (mit Drahtschutz / with wire protection)

Montageanleitung Steckbild / Assembly instruction pin layout

Stifteinsatz
Male insert

Buchseinsatz
Female insert

Montageausschnitt (Kontaktträger)
Panel cut out (insert)

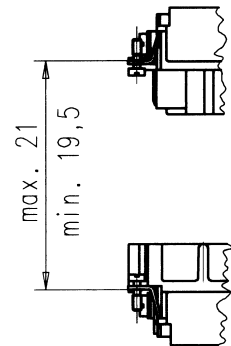
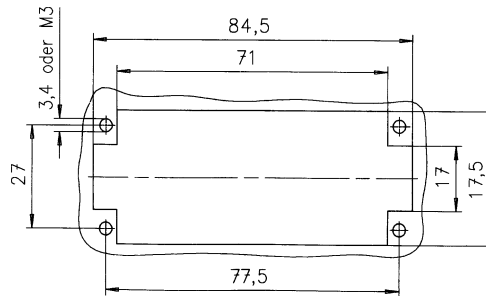
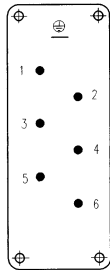
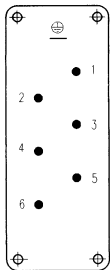

Derating Kurven / Derating curves

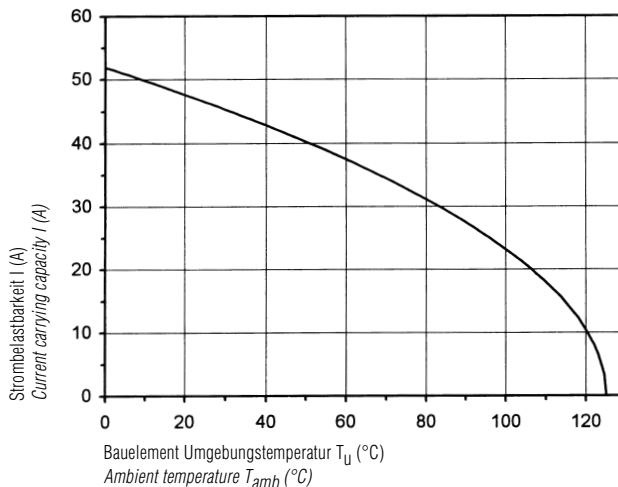

Anschlussquerschnitt 6 mm²
Wire gauge 6 mm²

HSE

C 146 HvE

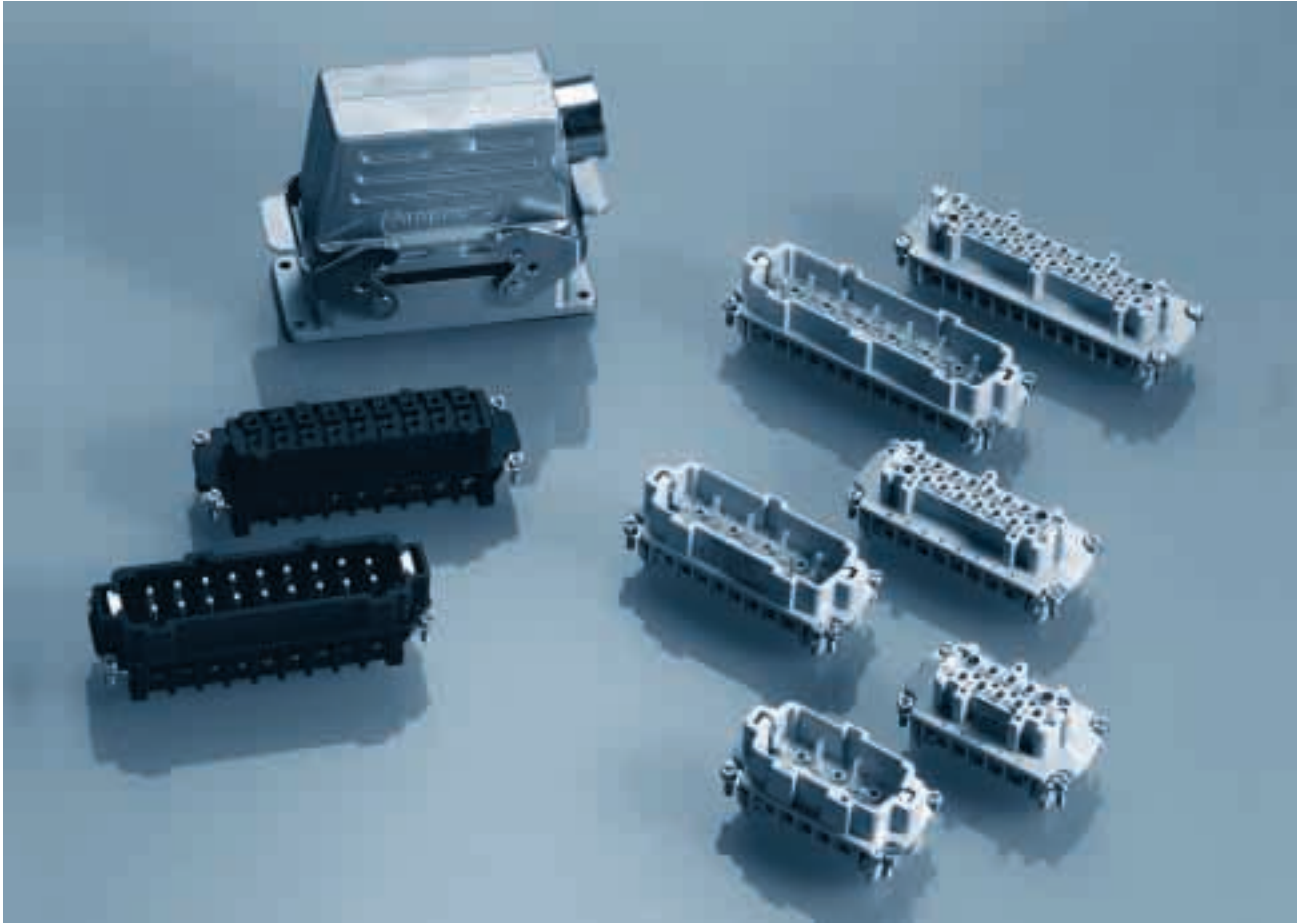

Hauptmerkmale		Main characteristics	
<ul style="list-style-type: none"> • Bemessungsspannung 660 V • Bemessungsstrom 16 A ... 22 A • Anschlussart: schrauben • 2 nacheilende Schaltkontakte • Polzahl: 3, 6, 10, 16, 20, 26, 32 		<ul style="list-style-type: none"> • Rated voltage 660 V • Rated current 16 A ... 22 A • Termination: screw • 2 delayed mating contacts • Number of contacts: 3, 6, 10, 16, 20, 26, 32 	
Zulassungen / Approvals Prüfstelle / Testhouse		Kennwerte / Characteristics	Zulassungs-Nummer / Approval-No.
SEV		660 V, 16 / 22 A	
UL		600 V, 10 A	E 63093
CSA		600 V, 20 A	48932
<p>Zulassungen beziehen sich im allgemeinen auf repräsentative Ausführungen der Steckverbinderserie. Prüfumfang und Prüfvorschrift auf Anfrage.</p>		<p><i>In general approvals refer to representative versions of the connector series. Extent and specification of tests upon request.</i></p>	

HvE

C 146 HvE

Kurzinformation Brief information

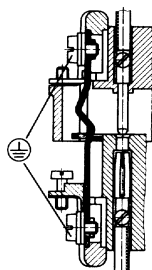
<p>Konstruktiver Aufbau der HvE-Steckverbindung</p> <p><i>Construction of connectors Type HvE</i></p>	<p>Die Steckverbindung der Serie C 146 HvE sind wie folgt aus der Baureihe C 146 E abgeleitet:</p> <p><i>The connectors of series C 146 HvE are based on series C 146 E with the following deviations:</i></p>
<p>Kontakteinsätze</p> <p><i>Inserts</i></p>	<p>Die 3, 6 und 10-pol. HVE-Kontakteinsätze gehen aus den 10, 16 und 24-pol. Isolierkörpern der Baureihe C 146 E durch Teilbestückung und 2 zusätzlichen, nachteilenden Schaltkontakten hervor. Lediglich die Polzahl 16 HVE besitzt in der Steckgeometrie abweichende Kontakträger. Ihre äußeren Abmessungen sind jedoch mit denen der Polzahl 24, Serie C 146 E identisch. Die nachteilenden Schaltkontakte ermöglichen den Anschluss einer Schützwicklung zum Zweck der elektrischen Verriegelung. Das bedeutet spannungslose Buchseneinsätze im ungesteckten Zustand.</p> <p>Werden Steckverbinder ohne Schaltleistung als Steckverbinder mit Schaltleistung eingesetzt, so müssen die elektrischen Leistungsdaten gemäß den Angaben des Herstellers reduziert werden. Diese Angaben sind beim Hersteller zu erfragen.</p> <p>C 146 E-Stifteinsätze (400 V) und C 146 HvE-Buchseneinsätze sind nicht miteinander steckbar, da</p> <p>a) bei den 3, 6 und 10-pol. Buchseneinsätzen 2 nicht belegte Kontaktkammern verschlossen sind. (Blindstopfen). b) die 16-pol. HVE-Kontakträger eine abweichende Steckgeometrie besitzen.</p> <p><i>The HVE-inserts with 3, 6 and 10 contacts are basically the same as the 10, 16 and 24-contacts inserts of series C 146 E. However they are only partly loaded with contacts and have two delayed mating pilot duty contacts. Only type 16 HVE has special inserts with a different contact arrangement. The mounting dimensions are however identical with the 24 contacts version of C 146 E. The delayed mating contacts are intended for switching a relay coil for electrically locking in order to have unloaded socket contacts in an unmated condition.</i></p> <p><i>If connectors without breaking capacity are used as connectors with breaking capacity the electrical power data must be reduced in accordance with the manufacturer's specification. These specifications are available from the manufacturer.</i></p> <p><i>C 146 E inserts with pin contacts are not intermatable with C 146 HvE inserts with socket contacts due to</i></p> <p>a) two empty contact holes are closed at 3, 6 and 10 contact inserts. b) the 16 contacts HVE insert has a different contact arrangement.</p>
<p>HvE</p> <p>Gehäuse: (aus Alu-Druckguss)</p> <p><i>Housings: (made of aluminium)</i></p>	<p>Verwendet werden beim 16-pol. HvE-Kontakteinsatz C 146 E-Gehäuse mit Isolationsauskleidung. (Isolationsfolie an Innenwand). Die Sperrstege an den Gehäuseinnenwänden (Schmalseite), die das Einsetzen der 660 V-Kontakträger in 400 V-Gehäusen verhindern, sind entfernt. Der 16-pol. HvE-Einsatz mit stirnseitigem Sperrstück ist jetzt montierbar.</p> <p><i>C 146 E housings with an inside insulation (plastic foil) are used for the 16-contacts insert. The inside barriers at the narrow sides preventing mounting of 660 V-inserts in 400 V housings are removed and the 16-contacts insert is now mountable.</i></p>
<p>Nicht genormte Steckverbinder, aber:</p> <p><i>No standard for this series, but:</i></p>	<p>Steck- und austauschbar mit Fremdfabrikaten</p> <p>a) Kontakteinsatz/Kontakteinsatz b) Kontakteinsatz/Gehäuse 6, 10, 16, 24 pol.</p> <p><i>Intermateable and exchangeable with other makes</i></p> <p>a) Contact insert to contact insert b) Contact insert to housing 6, 10, 16, 24 pin</p> <p>Gehäuse nach DIN 43620 (CECC 75 301-801, EN 175 301-801)</p> <p><i>Housings are designed according to DIN 43620 (CECC 75 301-801, EN 175 301-801)</i></p>
<p>Voreilender Schutzkontakt</p> <p><i>First-to-mate last-to-break protective ground contact</i></p>	

C 146 HvE

Technische Daten Characteristics

Allgemeine Kennwerte	General Characteristics	Norm / Standard	Wert / Value							
Polzahl	Number of contacts		3	6	10	16	20	26 ¹⁾	32	
Anschluss technik	Termination technique		schrauben / screw							
Anschlussquerschnitt	Wire gauge		0,25 - 2,5 mm ²							
Brennbarkeit	Flammability	UL 94	V-0							
Elektrische Kennwerte	Electrical Characteristics									
Bemessungsspannung	Rated voltage	IEC 60664-1	660 V ¹⁾ (600 V UL / CSA ³⁾)							
Verschmutzungsgrad	Pollution degree	IEC 60664-1	3							
Überspannungskategorie	Installation (overvoltage) category	IEC 60664-1	III							
Isolierstoffgruppe	Material group	IEC 60664-1	III a		II	IIIa	⁴⁾	II		
Bemessungs-Stoßspannung	Rated impulse withstand voltage	IEC 60664-1	8,0 kV							
Spannungsfestigkeit	Voltage proof	IEC 60512-2; Test 4 a	3,5 kV							
Strombelastbarkeit	Current carrying capacity	IEC 60512-3; Test 5 b	siehe Derating Kurven / see derating curves							
Durchgangswiderstand	Contact resistance	IEC 60512-2; Test 2 a	≤ 5 m Ω							
Isolationswiderstand	Insulation resistance	IEC 60512-2; Test 3 a	≥ 10 ¹² Ω ²⁾							
Klimatische Kennwerte	Climatical Characteristics									
Prüfklasse	Climatic category	IEC 60068-1	40 / 125 / 21							
Obere Grenztemperatur	Upper temperature	IEC 60512-6; Test 11 i	+ 125 °C / 1000 h							
Untere Grenztemperatur	Lower temperature	IEC 60512-6; Test 11 i	- 40 °C / 16 h							
Mechanische Kennwerte	Mechanical Characteristics									
⁵⁾ IP-Schutzart Stifteinsatz	IP-degree of protection pin insert	IEC 60529	ungesteckt/unmated IP00				gesteckt/mated IP20			
⁵⁾ IP-Schutzart Buchseneinsatz	IP-degree of protection socket insert	IEC 60529	ungesteckt/unmated IP20				gesteckt/mated IP20			
Gewicht Stifteinsatz	Weight pin insert		49 g	63 g	81 g	107 g	162 g	189 g	214 g	
Gewicht Buchseneinsatz	Weight socket insert		49 g	63 g	81 g	107 g	162 g	189 g	214 g	
Mechanische Lebensdauer	Mechanical operation	IEC 60512-5; Test 9 a	≥ 500 Steckzyklen / mating cycles							
Werkstoffe	Materials									
Kontakteinsatz	Insert		PC, GV		PA, GV	PC, GV	⁴⁾	PA, GV		
Kontakte	Contacts		Cu Zn (Messing / brass)							
Kontaktoberfläche	Contact plating		Ag (silber / silver)							
Farbe	Colour		grau / grey		schwarz black	grau grey	⁴⁾	schwarz black		

¹⁾ für Arbeitskontakte, 400 V für Schaltkontakte / for working contacts, 400 V for mating contacts

²⁾ bei Beanspruchung > 10¹⁰ Ω / Under operating conditions > 10¹⁰ Ω

³⁾ Hinweisschild für CSA-Anwendung siehe Seite 186 / Label for CSA application see page 186

⁴⁾ Kombination 10- und 16-polig; d.h. Werkstoff PC und PA / Combination 10 and 16 ways, i.e. material PC and PA

⁵⁾ IP-Schutzart im Anschlussbereich IP 10 / IP-degree of protection on termination side IP 10

C 146 HvE

3 +  + 2

660 V~

16 / 22 A

2 nacheilende Schaltkontakte
2 delayed mating contacts

Steckverbinder
Connectors

Gehäuse siehe Seite 136-143
Housings see page 136-143

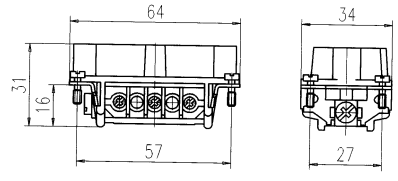
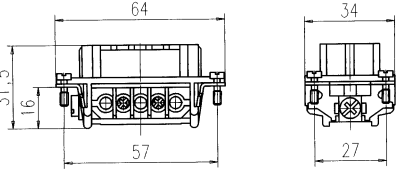
Bezeichnung - Abbildung Description - Figure	Maßzeichnung Drawing	Bestell Nr. / Part No.	
		Stifteinsatz / Male insert	Buchseneinsatz / Female insert
Kontakteinsatz Schraubanschluss ¹⁾ Contact insert screw termination ¹⁾	<p>Stifteinsatz Male insert</p>  <p>Buchseneinsatz Female insert</p> 	C146 10A003 102 3	C146 10B003 102 3

Montageanleitung, Steckbild / Assembly instruction, pin layout

Stifteinsatz
Male insert

Buchseneinsatz
Female insert

Montageausschnitt (Kontaktträger)
Panel cut out (insert)

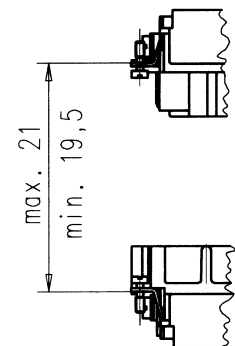
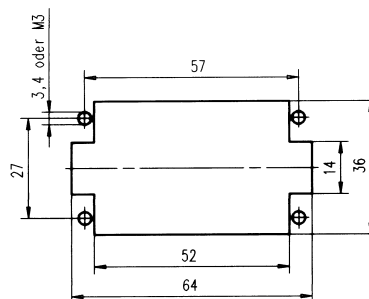
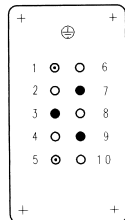
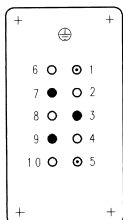

- Arbeitskontakt / working contact
- ⊙ Schaltkontakt / mating contact
- Leerstelle / without contact

Derating Kurve / Derating curve

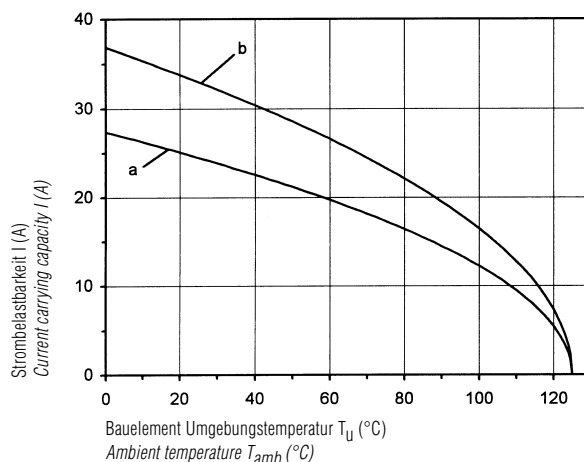

Begrenzung durch Leiter beachten
Notice restriction of wire

Kurve a Anschlussquerschnitt 1,5 mm²
Curve a wire gauge 1,5 mm²

Kurve b Anschlussquerschnitt 2,5 mm²
Curve b wire gauge 2,5 mm²

1) mit Drahtschutz / with wire protection

C 146 HvE

6 +  + 2

660 V~

16 / 22 A

2 nacheilende Schaltkontakte
2 delayed mating contacts

Steckverbinder
Connectors

Gehäuse siehe Seite 144-151
Housings see page 144-151

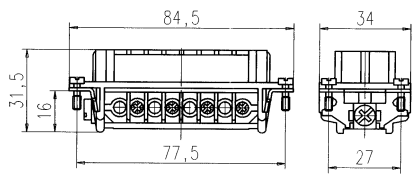
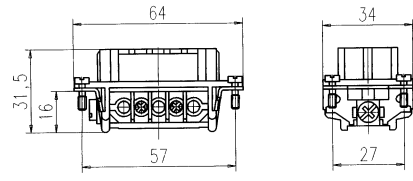
Bezeichnung - Abbildung Description - Figure	Maßzeichnung Drawing	Bestell Nr. / Part No.	
		Stifteinsatz / Male insert	Buchseinsatz / Female insert
Kontakteinsatz Schraubanschluss ¹⁾ Contact insert screw termination ¹⁾	<p>Stifteinsatz Male insert</p>  <p>Buchseinsatz Female insert</p> 	C146 10A006 102 3	C146 10B006 102 3

Montageanleitung, Steckbild / Assembly instruction, pin layout

Stifteinsatz
Male insert

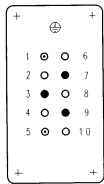

- Arbeitskontakt / working contact
- ⊙ Schaltkontakt / mating contact
- Leerstelle / without contact

Buchseinsatz
Female insert

Montageausschnitt (Kontaktträger)
Panel cut out (insert)

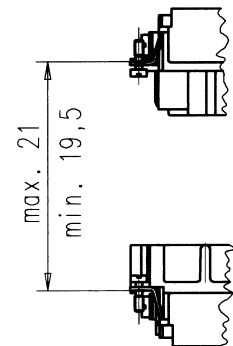
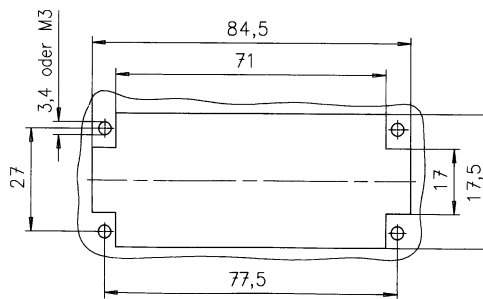

Derating Kurve / Derating curve

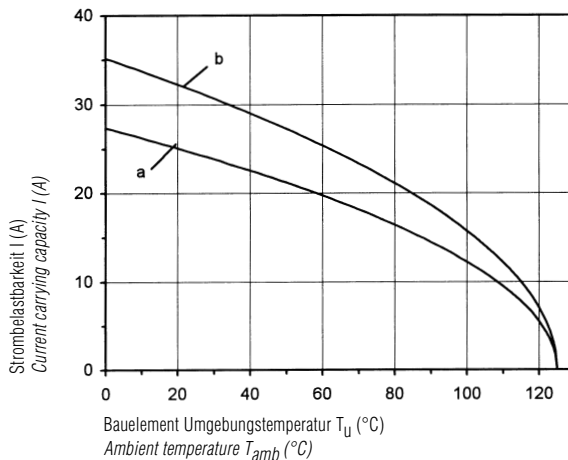

Begrenzung durch Leiter beachten
Notice restriction of wire

Kurve a Anschlussquerschnitt 1,5 mm²
Curve a wire gauge 1,5 mm²

Kurve b Anschlussquerschnitt 2,5 mm²
Curve b wire gauge 2,5 mm²

1) mit Drahtschutz / with wire protection

C 146 HvE

10 +  + 2

Steckverbinder
Connectors

660 V~

16 / 22 A

2 nacheilende Schaltkontakte
2 delayed mating contacts

Gehäuse siehe Seite 152-159
Housings see page 152-159

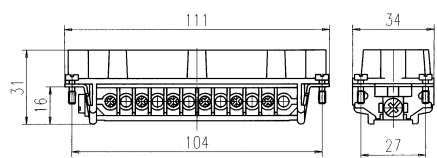
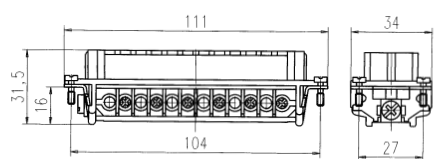
Bezeichnung - Abbildung Description - Figure	Maßzeichnung Drawing	Bestell Nr. / Part No.	
		Stifteinsatz / Male insert	Buchseinsatz / Female insert
Kontakteinsatz Schraubanschluss ¹⁾ Contact insert screw termination ¹⁾	<p>Stifteinsatz Male insert</p>  <p>Buchseinsatz Female insert</p> 	C146 10A010 102 3	C146 10B010 102 3

Montageanleitung, Steckbild / Assembly instruction, pin layout

Stifteinsatz
Male insert

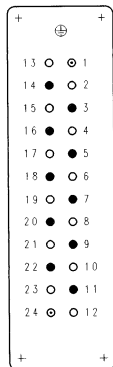

Buchseinsatz
Female insert

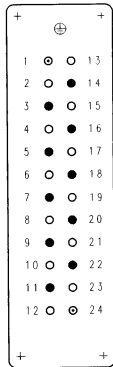

Montageausschnitt (Kontaktträger)
Panel cut out (insert)

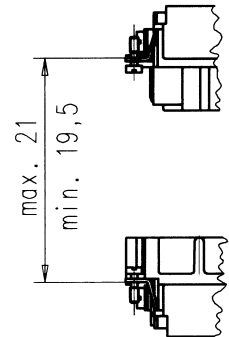
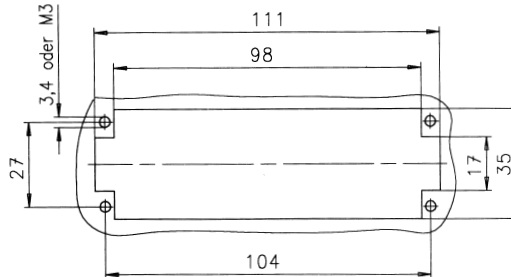

- Arbeitskontakt / working contact
- ⊙ Schaltkontakt / mating contact
- Leerstelle / without contact

Derating Kurve / Derating curve

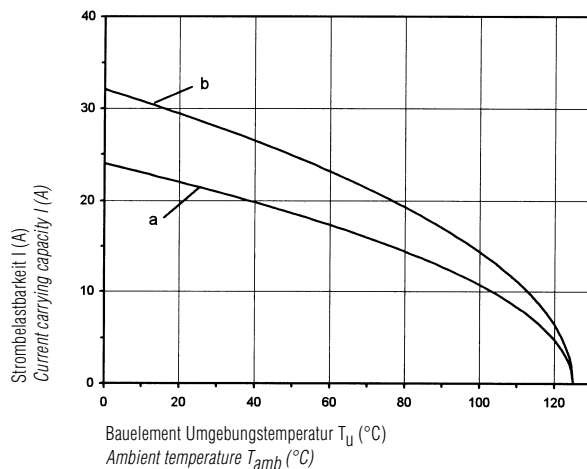

Begrenzung durch Leiter beachten
Notice restriction of wire

Kurve a Anschlussquerschnitt 1,5 mm²
Curve a wire gauge 1,5 mm²

Kurve b Anschlussquerschnitt 2,5 mm²
Curve b wire gauge 2,5 mm²

1) mit Drahtschutz / with wire protection

C 146 HvE

16 +  + 2

660 V~

16 / 22 A

2 nacheilende Schaltkontakte
2 delayed mating contacts

Steckverbinder
Connectors

Gehäuse siehe Seite 164-165
Housings see page 164-165

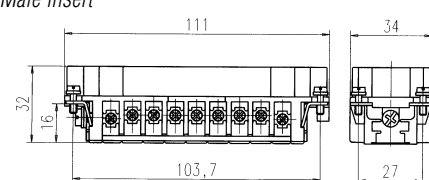
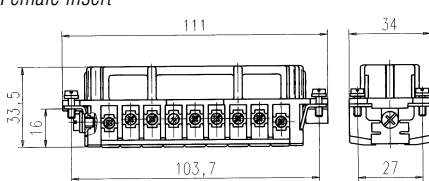
Bezeichnung - Abbildung Description - Figure	Maßzeichnung Drawing	Bestell Nr. / Part No.	
		Stifteinsatz / Male insert	Buchseinsatz / Female insert
Kontakteinsatz Schraubanschluss ¹⁾ Contact insert screw termination ¹⁾ 	Stifteinsatz Male insert  Buchseinsatz Female insert 	C146 10A016 102 3 C146 10A016 002 3 (ohne Drahtschutz without wire protection)	C146 10B016 102 3 C146 10B016 002 3 (ohne Drahtschutz without wire protection)

Montageanleitung, Steckbild / Assembly instruction, pin layout

Stifteinsatz
Male insert

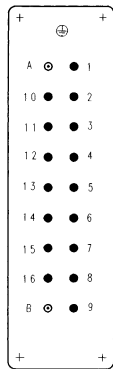

Buchseinsatz
Female insert

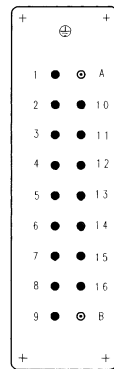

Montageausschnitt (Kontaktträger)
Panel cut out (insert)

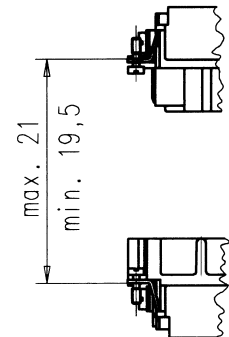
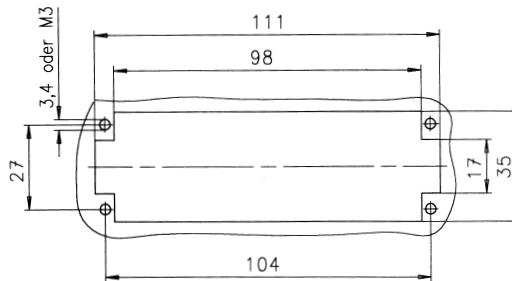

- Arbeitskontakt / working contact
- ⊙ Schaltkontakt / mating contact

Derating Kurve / Derating curve

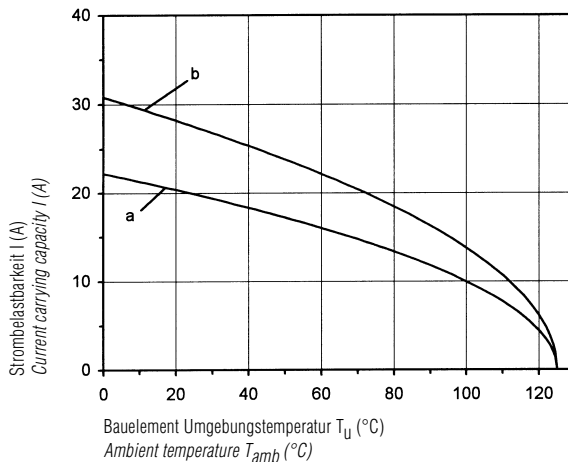

Begrenzung durch Leiter beachten
Notice restriction of wire

Kurve a Anschlussquerschnitt 1,5 mm²
Curve a wire gauge 1,5 mm²

Kurve b Anschlussquerschnitt 2,5 mm²
Curve b wire gauge 2,5 mm²

1) mit Drahtschutz / with wire protection

C 146 HvE

20 + + 4

26 + + 4

32 + + 4

Steckverbinder
Connectors

660 V~

16 / 22 A

4 nacheilende Schaltkontakte
4 delayed mating contacts



Gehäuse siehe Seite 160–163
Housings see page 160–163

Bezeichnung - Abbildung Description - Figure	Maßzeichnung / Drawing		Bestell Nr. / Part No.	
	Stifteinsatz / Male insert	Buchseinsatz / Female insert	Stifteinsatz / Male insert	Buchseinsatz / Female insert
Kontakteinsätze Schraubanschluss ¹⁾ Contact inserts screw termination ¹⁾ 20 + + 4 			C146 10A010 102 3 (1 - 24) + C146 10A010 104 3 (25 - 48)	C146 10B010 102 3 (1 - 24) + C146 10B010 104 3 (25 - 48)
Kontakteinsätze Schraubanschluss ¹⁾ Contact inserts screw termination ¹⁾ 26 + + 4 			C146 10A010 102 3 (1 - 24) + C146 10A016 102 3 (1 - 16)	C146 10A010 102 3 (1 - 24) + C146 10B016 102 3 (1 - 16)
Kontakteinsätze Schraubanschluss ¹⁾ Contact inserts screw termination ¹⁾ 32 + + 4 			C146 10A016 102 3 (1 - 16) + C146 10A016 104 3 (17 - 32)	C146 10B016 102 3 (1 - 16) + C146 10B016 104 3 (17 - 32)

1) mit Drahtschutz / with wire protection

C 146 S



Hauptmerkmale		Main characteristics	
<ul style="list-style-type: none"> • Bemessungsspannung 125 - 600 V • Bemessungsstrom 10 A ... 70 A • Anschlussart: crimpen, schrauben, löten • Polzahl: 4, 57 		<ul style="list-style-type: none"> • Rated voltage 125 - 600 V • Rated current 10 A ... 70 A • Termination: crimping, screw, solder • Number of contacts: 4, 57 	
Zulassungen / Approvals	Prüfstelle / Testhouse	Kennwerte / Characteristics	Zulassungs-Nummer / Approval-No.
UL		600 V, 40 A (4 pol + PE / 4 contacts + PE)	E 63093
CSA		600 V, 40 A (4 pol + PE / 4 contacts + PE)	48932
<p>Zulassungen beziehen sich im allgemeinen auf repräsentative Ausführungen der Steckverbinderserie. Prüfumfang und Prüfvorschrift auf Anfrage.</p>		<p><i>In general approvals refer to representative versions of the connector series. Extent and specification of tests upon request.</i></p>	

S

Allgemeine Hinweise



General information

- Kontakteinsätze ohne Crimpkontakte (bei Kontakteinsatz mit Crimpanschluss).
- Steckverbinder der Serie C 146 S dürfen nicht unter Last betätigt werden.
- Crimpwerkzeuge siehe separater Katalog „Werkzeuge“.
- Für die Einsätze der Serie C 146 S können sowohl niedrige, wie auch hohe Gehäusebauformen verwendet werden.
- Verarbeitungs- und Montagehinweise von Crimpkontakten, siehe Katalog „Werkzeuge“.

- *Contact inserts without crimp contacts.*
- *Do not mate or unmate A 146 S connectors under electrical load.*
- *Crimping tools see separate catalogue „Tools“.*
- *Low and high profile housings for C 146 S series inserts.*
- *Processing instruction for crimp contacts see catalogue „Tools“.*

Hoher Schutz vor
Fehlsteckungen

High protection
against mismatching

Buchsenkontakteinsatz mit trichterförmiger,
verengter Stecköffnung.
(hohe Steck- und Kontaktsicherheit)

*Female inserts with funnel shaped contact
entry avoids mismatching.
(high security in mating and contacting)*

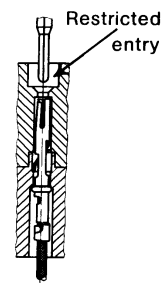

Voreilender Schutzkontakt
(am Kontakteinsatz)

*First-to-mate last-to-break
protective ground contact
(at the contact insert)*



Allgemeine Kennwerte	General Characteristics	Norm / Standard	Wert / Value		
Polzahl	Number of contacts		4 + ⊕	57 + ⊕	57 + ⊕
Anschluss technik	Termination technique		schrauben screw	löten solder	crimpen crimp
Anschlussquerschnitt	Max. wire gauge		16 mm ²	1,5 mm ²	2,5 mm ²
Schutzart	Protection class		IP 54		
Maximaler Leiterquerschnitt	Max. wire diameter		–	–	3,5 mm
Brennbarkeit	Flammbarkeit	UL 94	V-0	V-1	V-1
Elektrische Kennwerte	Electrical Characteristics				
Bemessungsspannung	Rated voltage	IEC 60664-1	630 V	200 V	150 V
Verschmutzungsgrad	Pollution degree	IEC 60664-1	3		
Isolierstoffgruppe	Material group	IEC 60664-1	II	I	III a
Bemessungs-Stoßspannung	Rated impulse withstand voltage	IEC 60664-1	6,0 kV	4,0 kV	3,0 kV
Spannungsfestigkeit	Voltage proof	IEC 60512-2; Test 4 a	3,5 kV	1,6 kV	1,4 kV
Strombelastbarkeit	Current carrying capacity	IEC 60512-2	siehe Derating Kurven / see derating curves		
Durchgangswiderstand	Contact resistance	IEC 60512-2	< 5 m Ω		
Isolationswiderstand	Insulation resistance	IEC 60512-2	≥ 10 ¹⁰ Ω	≥ 10 ¹⁰ Ω	≥ 10 ¹⁰ Ω
Luftstrecke	Clearance	IEC 60664-1	6,4 mm	2 mm	1,6 mm
Kriechstrecke	Creepage	IEC 60664-1	9,5 mm	2,5 mm	3 mm
Klimatische Kennwerte	Climatical Characteristics				
Prüfklasse	Climatic category	IEC 60068-1	40 / 125 / 56	25 / 85 / 21	40 / 125 / 21
Mechanische Kennwerte	Mechanical Characteristics				
Gesamt Steck- und Ziehkraft	Insertion and withdrawal forces	IEC 60529	≤ 70 N	≤ 200 N	≤ 250 N
¹⁾ IP-Schutzart Stifteinsatz	IP-degree of protection pin insert	IEC 60529	ungesteckt/unmated IP00	gesteckt/mated IP20	
¹⁾ IP-Schutzart Buchseneinsatz	IP-degree of protection socket insert	IEC 60529	ungesteckt/unmated IP20	gesteckt/mated IP20	
Gewicht Stifteinsatz	Weight Male insert		150 g	205 g	60 g
Gewicht Buchseneinsatz	Weight Female insert		170 g	95 g	55 g
Mechanische Lebensdauer	Mechanical operation		> 500 Steckzyklen / mating cycles		
Werkstoffe	Materials				
Kontakteinsatz	Insert		PA GV	DAP	PPO
Schraubkontakte	Screw contacts		CuZn (Messing/brass)		
Crimpkontakt Stift	Male crimp contacts		CuZn (Messing/brass)		
Crimpkontakt Buchse	Female crimp contacts		CuSn (Zinnbronze / Tin bronze)		
Kontaktoberfläche	Contact plating		Ag	Ag	Ag
Farbe	Colour		grau / grey		
Gehäuse	Housings		Aluminium Druckguss / Aluminium die cast		
Dichtgummi	Rubber gasket		Neoprene / Neoprene		

¹⁾ IP-Schutzart im Anschlussbereich der Schraub-/Lötausführung IP 00
IP-degree of protection on termination side of screw/solder version IP 00

C 146 S

4 + 

500 V~

70 A

Steckverbinder
Connectors

Gehäuse siehe Seite 112
Housings see page 112

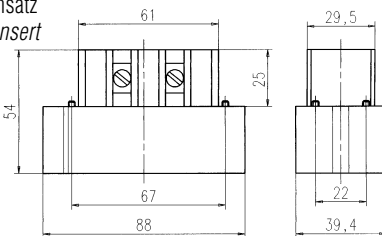
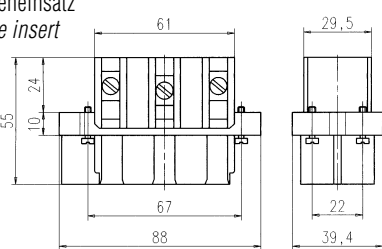
Bezeichnung - Abbildung Description - Figure	Maßzeichnung Drawing	Bestell Nr. / Part No.	
		Stifteinsatz / Male insert	Buchseinsatz / Female insert
Kontakteinsatz Schraubanschluss mit Drahtschutz Contact insert screw termination with wire protection 	Stifteinsatz Male insert  Buchseinsatz Female insert 	C146 10A004 102 6	C146 10B004 102 6

Steckbild / Pin layout

Stifteinsatz
Male insert

Buchseinsatz
Female insert

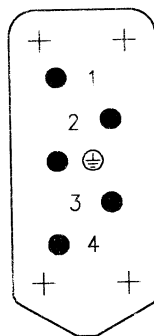
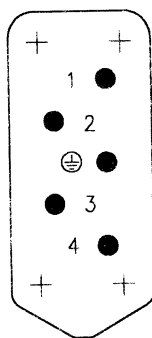

Derating Kurven / Derating curves

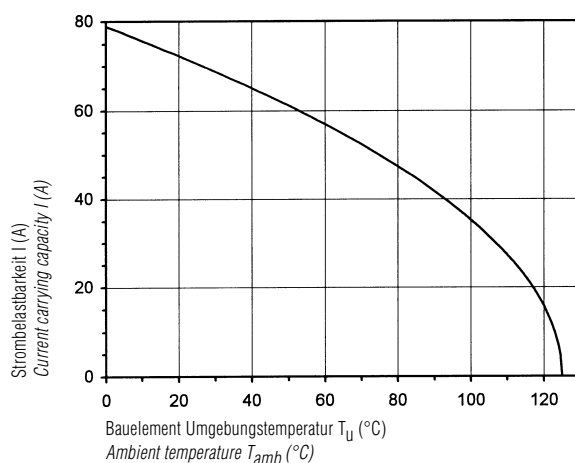





Anschlussquerschnitt 16 mm²
Wire gauge 16 mm²

C 146 S
57 + 

125 V~ 10 A

Steckverbinder
Connectors

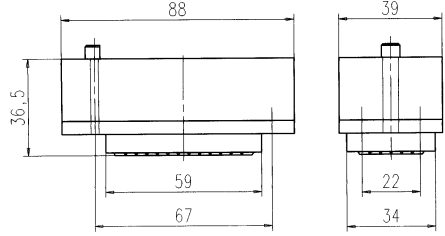
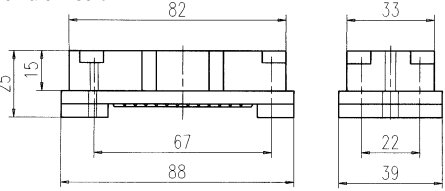
Gehäuse siehe Seite 112
Housings see page 112

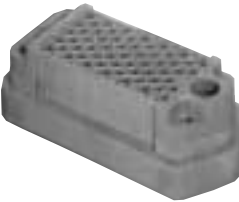
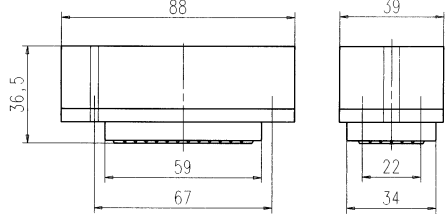
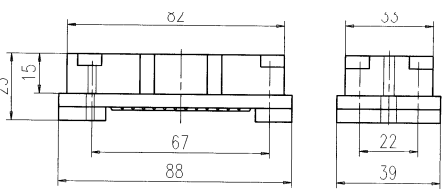
Bezeichnung - Abbildung Description - Figure	Maßzeichnung Drawing	Bestell Nr. / Part No.	
		Stifteinsatz / Male insert	Buchseneinsatz / Female insert
<p>Kontakteinsatz Crimpanschluss mit Kodiereinrichtung 6 Pos. Contact insert crimp termination incl. polarisation 6 Pos.</p>  	<p>Stifteinsatz Male insert</p>  <p>Buchseneinsatz Female insert</p> 	C146 10A057 000 6	C146 10B057 000 6
<p>Kontakteinsatz Crimpanschluss ohne Kodiereinrichtung Contact insert crimp termination without polarisation</p>  	<p>Stifteinsatz Male insert</p>  <p>Buchseneinsatz Female insert</p> 	C146 10A057 801 6	C146 10B057 801 6

C 146 S
57 + 

Crimpkontakte
Crimp contacts

Gestanzte Einzelkontakte
Stamped single contacts

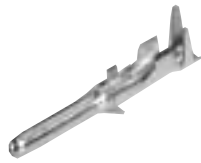

Gestanzte Bandkontakte für Crimpzangen
Stamped contacts on reel for hand crimping tools



200 / 100 Stück
200 / 100 pcs

Gestanzte Bandkontakte für Crimpmaschinen
Stamped contacts on reel for crimp machines



2000 Stück
(Zuführung links oder rechts)
2000 pcs
(feeding left or right hand side)

Lieferform <i>Supplied as</i>	für Leiterquerschnitt <i>for wire gauge</i>	AWG	Stückzahl <i>Pieces</i>	Bestell Nr. ¹⁾ / Part No. ¹⁾	
				Stiftkontakt / Male contact	Buchsenkontakt / Female contact
Gestanzte Einzelkontakte / <i>Stamped single contacts</i>					
	0,5 - 1,5 mm ²	20 - 16	100	VN01 025 0007 (101)	VN02 025 0001 (101)
	1,5 - 2,5 mm ²	16 - 14	100	VN01 025 0008 (101)	VN02 025 0010 (101)
Gestanzte Bandkontakte für Crimpzangen / <i>Stamped contacts on reel for hand crimping tools</i>					
	0,5 - 1,5 mm ²	20 - 16	200	ZN01 025 0007 (1)	ZN02 025 0001 (1)
	1,5 - 2,5 mm ²	16 - 14	100	ZN01 025 0008 (1)	ZN02 025 0010 (1)
Gestanzte Bandkontakte für Crimpmaschinen / <i>Stamped contacts on reel for crimp machines</i>					
Kontaktzuführung rechts <i>Contact feeding right hand side</i>	0,5 - 1,5 mm ²	20 - 16	2000	HN01 025 0007 (1)	HN02 025 0001 (1)
	1,5 - 2,5 mm ²	16 - 14	2000	HN01 025 0008 (1)	HN02 025 0010 (1)
Kontaktzuführung links <i>Contact feeding left hand side</i>	0,5 - 1,5 mm ²	20 - 16	2000	TN01 025 0007 (1)	TN02 025 0001 (1)
	1,5 - 2,5 mm ²	16 - 14	2000	TN01 025 0008 (1)	TN02 025 0010 (1)

Steckbild / *Pin layout*

Stifteinsatz
Male insert

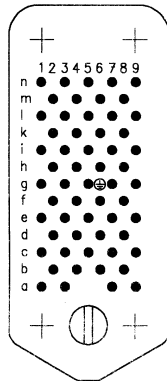

Buchseneinsatz
Female insert

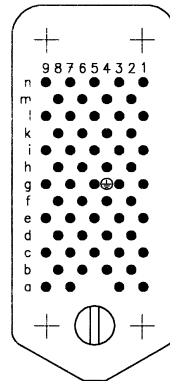

Derating Kurven / *Derating curves*

Crimp / crimp

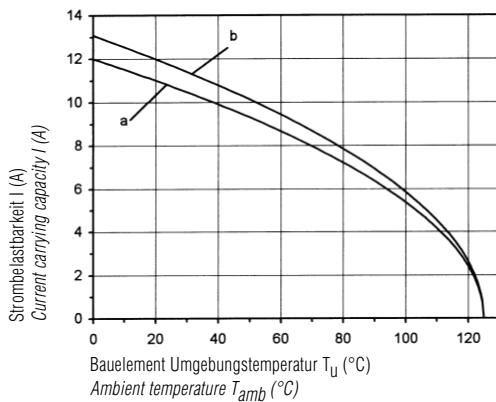

Kurve a Anschlussquerschnitt 1,5 mm² / *Curve a wire gauge 1,5 mm²*
Kurve b Anschlussquerschnitt 2,5 mm² / *Curve b wire gauge 2,5 mm²*

Löt / solder

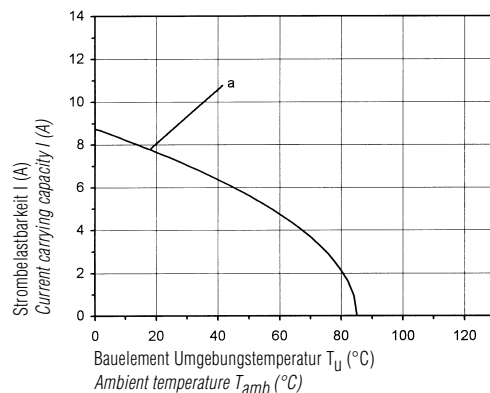





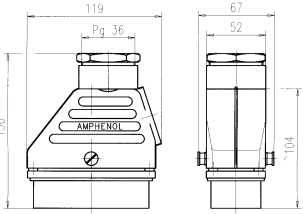

¹⁾ Erläuterung der Bestell-Nr. für die Kontakte siehe Seite 4
¹⁾ *Explanation of the Part No. for contacts see page 4*

Abisolierlängen siehe S. 208
Stripping length see p. 208

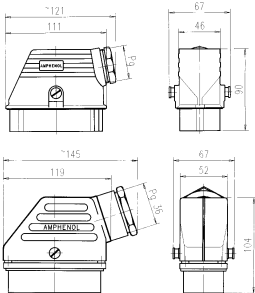
C 146 S 4 pol.
C 146 S 57 pol.

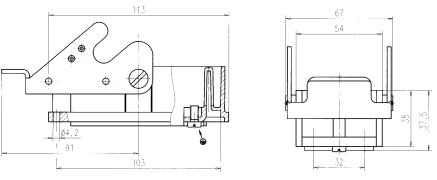
Gehäuse
Hoods, housings

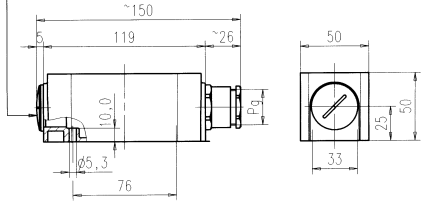
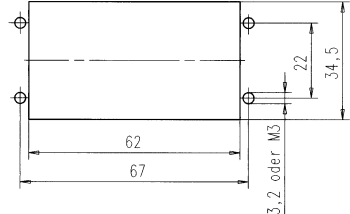
Bezeichnung - Abbildung Description - Figure	Maßzeichnung Drawing	PG	Bestell Nr. / Part No. Niedrige Bauform / Low profile Hohe Bauform / High profile	
Gehäuseoberteile / Hoods				
Tüllengehäuse, Abgang oben Hood, top entry 		36	T 1860 021	
Tüllengehäuse, Abgang Seite Hood, side entry 		21 29 36	T 1860 000 T 1860 010 T 1860 022	
Gehäuseunterteile / Housings				
Anbaugehäuse ¹⁾ Housing bulkhead mounting ¹⁾ 		-	T 1861 002 T 1861 012 (mit Feder am Verriegelungsbügel with spring cover on locking lever)	
Sockelgehäuse, 1 Kabelabgang Housing, single side entry 	Blindstopfen Blind way Bouchon obturateur 	-	T 1862 001	
Montageausschnitt für Anbaugehäuse / Panel cut for housing bulkhead mounting				
				

¹⁾ incl. Dichtung / incl. gasket

C 146 Gehäuse / *Housings*



Für Serien

- C 146 D / DD
- C 146 E
- C 146 M
- C 146 A
- C 146 HSE
- C 146 HVE

For series

- C 146 D / DD
- C 146 E
- C 146 M
- C 146 A
- C 146 HSE
- C 146 HVE

C 146 Gehäuse Housings

Kurzinformation Brief information

Allgemeine Hinweise



General information

- Die Steckverbindungen der Serie C 146 sind für Einsatzbereiche im allgemeinen Maschinen-, Anlagen- und Apparatebau, Steuerungs- und Elektrogerätebau vorgesehen.
Die Überprüfung, ob die Steckverbindung anderen als den angegebenen Vorschriften entspricht, bzw. ob diese in speziell von uns nicht vorhersehbaren Anwendungsbereichen eingesetzt werden kann, obliegt dem Anwender.
 - Bei Kupplungsgehäusen ist eine ausreichende Zugentlastung sicherzustellen.
 - Bei Einsatz von Gehäusen ohne Stützen wird der Kabelraum beeinträchtigt.
 - Die angegebenen Bemaßungen bei den Montageausschnitten stellen Anhaltswerte dar und sind im konkreten Anwendungsfall auf die Produkte abzustimmen.
 - Die Dichtfläche bei den Anbaugehäusen muss eben und grattfrei sein.
- The connectors of our C 146 series are designed for use in machine tools, general electric installations and applications as well as for industrial control and other electrical equipment.
Other applications than the above mentioned are in the responsibility of the user.*
- *For cable to cable connections a suitable cable clamp has to be used.*
 - *The use of housings without stud impairs the cable room.*
 - *The indicated dimensions with the panel cut-outs represent reference values and are in the concrete application with products to be co-ordinated.*
 - *The sealing area of the housing has to be level and free of burrs.*

Große Gehäuseauswahl
in 2 Bauhöhen

Large range of housings
in 2 different heights



Genormte Steckverbindergehäuse
nach DIN 43652
DIN EN 175 301-801 (DIN 43652)

Standardised connector housings
according DIN 43652
DIN EN 175 301-801 (DIN 43652)

Weitere Sonderausführung
auf Anfrage

Special housing on request



z. B. Korrosions geschützte Gehäuse
e. G. corrosion protected housings



Sondertypen
Customer specials

C 146 Gehäuse Housings











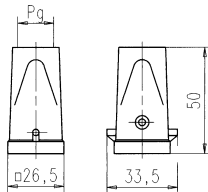

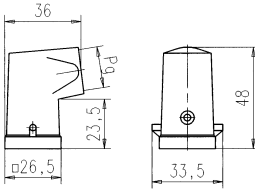
Technische Daten Characteristics

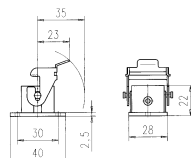
Allgemeine Kennwerte	General Characteristics	Norm / Standard	Wert / Value
Schutzart Gehäuse	<i>Protection class housing</i>		IP 65
Schutzart Klappdeckel verriegelt unverriegelt	<i>Protetion class spring cover locked spring loaded</i>		IP 65 IP 54
Verriegelungssystem	<i>Locking system</i>	DIN EN 175 301-801 (DIN 43 652)	1 Längsbügel / <i>1 locking lever</i> 2 Querbügel / <i>2 locking levers</i>
Klimatische Kennwerte	Climatical Characteristics		
Prüfklasse	<i>Climatic category</i>	IEC 60068-1	40 / 100 / 21
Temperaturbereich	<i>Temperature range</i>	IEC 60068-1	- 40 °C / + 100 °C
Obere Grenztemperatur	<i>Upper temperature</i>	IEC 60512-6; Test 11 i	+ 100 °C / 1000 h
Untere Grenztemperatur	<i>Lower temperature</i>	IEC 60512-6; Test 11 i	- 40 °C / 16 h
Mechanische Kennwerte	Mechanical Characteristics		
Mechanische Lebensdauer	<i>Mechanical operation</i>	IEC 60512-5; Test 9 a	≥ 500 Zyklen / <i>cycles</i>
Werkstoffe	Materials		
Gehäuse	<i>Housings</i>	DIN EN 175 301-801 (DIN 43 652)	Aluminium-Druckguss <i>Aluminium die cast alloy</i>
Kunststoffgehäuse	<i>Thermoplastic housing</i>		PA
Metallgehäuse D 7	<i>Metal housing D 7</i>		Zink-Druckguss / <i>Zinc die cast alloy</i>
Schutzkappe	<i>Protective cover</i>		PA
Dichtgummi	<i>Rubber gasket</i>		NBR
Verriegelung	<i>Locking lever</i>		Stahl / verzinkt <i>steel / zinc coated</i>
Oberfläche EMV Gehäuse	<i>Surface EMV housings</i>		Spezialbeschichtung / <i>special surface</i>

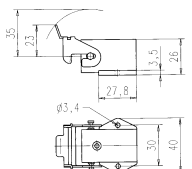
C 146 D 7 pol.
C 146 A 3/4 pol.

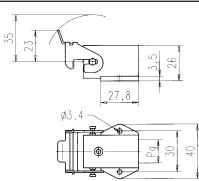
Gehäuse Kunststoff
Housings thermoplastic

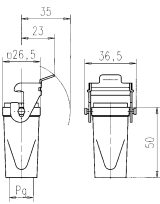

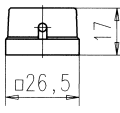







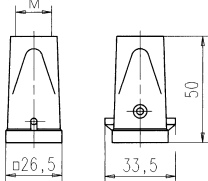

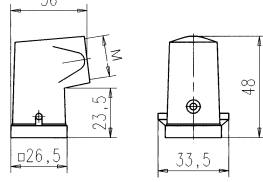
PG-Gewinde
PG-thread

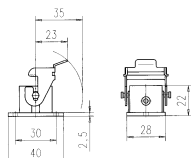
Bezeichnung - Abbildung Description - Figure	Maßzeichnung Drawing	PG	Bestell Nr. Part No.
Gehäuseoberteile / Hoods			
Tüllengehäuse, gerader Kabelausgang Hood, top entry 		11	C146 10G003 600 4
Tüllengehäuse, seitlicher Kabelausgang Hood, side entry 		11	C146 10G003 500 4
Gehäuseunterteile / Housings			
Anbaugehäuse (incl. Flachdichtung) Housing bulkhead mounting (incl. gasket) 	 Montageausschnitt/panel cut out: 22 x 22 mm	-	C146 10F003 000 4
Anbaugehäuse (incl. Flachdichtung) Housing bulkhead end mounting (incl. gasket) 	 Montageausschnitt/panel cut out: 22 x 22 mm	-	C146 10F003 004 4
Sockelgehäuse, 1 Kabelausgang Housing, single side entry 	 Montageausschnitt/panel cut out: 22 x 22 mm	11	C146 10F003 500 4
Kupplungsgehäuse, 1 Kabelausgang Hood, cable to cable coupling 		11	C146 10G003 804 4
Schutzkappen / Protective cover			
Schutzkappe für Gehäuseunterteile (nur in Verbindung mit Stifteinsatz) Cover for housings (only in connection with male insert) 		-	C146 10Z003 100 4

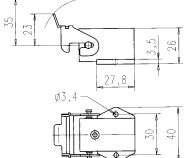
C 146 D 7 pol.
C 146 A 3/4 pol.

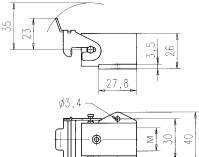
Gehäuse Kunststoff
Housings thermoplastic

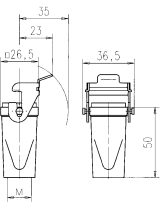

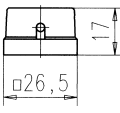







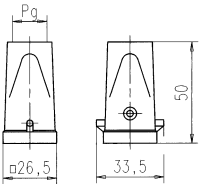

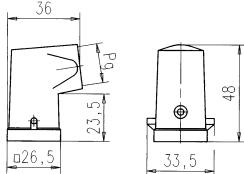
Metrisches Gewinde
Metric thread

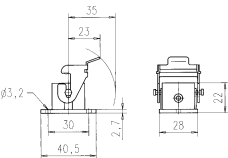
Bezeichnung - Abbildung Description - Figure	Maßzeichnung Drawing	M	Bestell Nr. / Part No.	
			mit Stutzen / with stud	ohne Stutzen / without stud
Gehäuseoberteile / Hoods				
Tüllengehäuse, gerader Kabelausgang Hood, top entry 		20	C146 10R003 600 4 (grau)	
		20	C146 16R003 600 4 (sw)	
Tüllengehäuse, seitlicher Kabelausgang Hood, side entry 		20	C146 10R003 500 4 (grau)	
		20	C146 16R003 500 4 (sw)	
Gehäuseunterteile / Housings				
Anbaugehäuse (incl. Flachdichtung) Housing bulkhead mounting (incl. gasket) 	 Montageausschnitt/panel cut out: 22 x 22 mm	–	C146 10F003 000 4 (grau)	
			C146 16F003 000 4 (sw)	
Anbaugehäuse (incl. Flachdichtung) Housing bulkhead end mounting (incl. gasket) 	 Montageausschnitt/panel cut out: 22 x 22 mm	–	C146 10F003 004 4	
Sockelgehäuse, 1 Kabelausgang Housing, single side entry 	 Montageausschnitt/panel cut out: 22 x 22 mm	20	C146 10N003 500 4 (grau)	mit Verschraubung/ with gland bushing
		20	C146 16N003 500 4 (sw)	mit Verschraubung/ with gland bushing
Kupplungsgehäuse, 1 Kabelausgang Hood, cable to cable coupling 		20	C146 10R003 804 4	
Schutzkappen / Protective cover				
Schutzkappe für Gehäuseunterteile (nur in Verbindung mit Stifteinsatz) Cover for housings (only in connection with male insert) 		–	C146 10Z003 100 4	

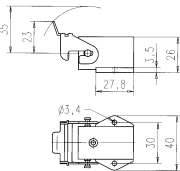
C 146 D 7 pol.
C 146 A 3/4 pol.

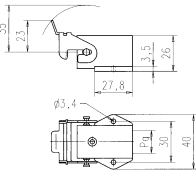
Gehäuse Metall
Housings metal

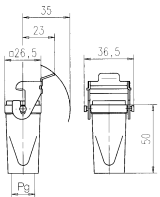
PG-Gewinde
PG-thread

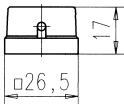









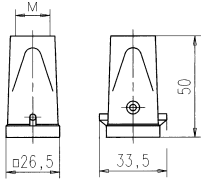

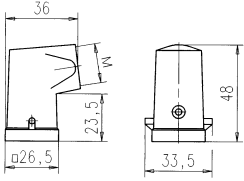
Bezeichnung - Abbildung Description - Figure	Maßzeichnung Drawing	PG	Bestell Nr. Part No.
Gehäuseoberteile / Hoods			
Tüllengehäuse, gerader Kabelausgang Hood, top entry 		11	C146 30G003 600 4
Tüllengehäuse, seitlicher Kabelausgang Hood, side entry 		11	C146 30G003 500 4
Gehäuseunterteile / Housings			
Anbaugehäuse (incl. Flachdichtung) Housing bulkhead mounting (incl. gasket) 		-	C146 30F003 000 4
Anbaugehäuse (incl. Flachdichtung) Housing bulkhead end mounting (incl. gasket) 		-	C146 30F003 004 4
Sockelgehäuse, 1 Kabelausgang Housing, single side entry 		11	C146 30F003 500 4
Kupplungsgehäuse, 1 Kabelausgang Hood, cable to cable coupling 		11	C146 30G003 804 4
Schutzkappen / Protective cover			
Schutzkappe für Gehäuseunterteile (nur in Verbindung mit Stifteinsatz) Cover for housings (only in connection with male insert) 		-	C146 30Z003 100 4

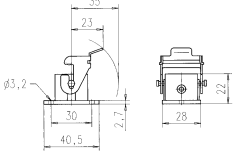
Verschraubung für Tüllen- und Sockelgehäuse siehe Seite 180 - 183 / gland bushings for hoods and housing see page 180-183

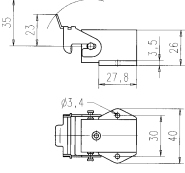
C 146 D 7 pol.
C 146 A 3/4 pol.

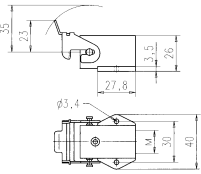
Gehäuse Metall (metrisch)
Housings metal (metric)

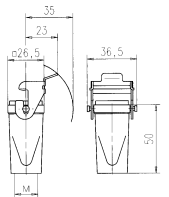
Metrisches Gewinde
Metric thread

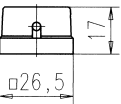





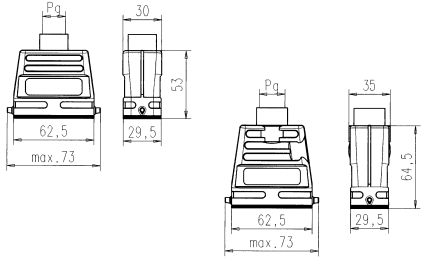

Bezeichnung - Abbildung Description - Figure	Maßzeichnung Drawing	M	Bestell Nr. / Part No.	
			mit Stutzen / with stud	ohne Stutzen / without stud
Gehäuseoberteile / Hoods				
Tüllengehäuse, gerader Kabelausgang Hood, top entry 		20	C146 30R003 600 4	
Tüllengehäuse, seitlicher Kabelausgang Hood, side entry 		20	C146 30R003 500 4	
Gehäuseunterteile / Housings				
Anbaugehäuse (incl. Flachdichtung) Housing bulkhead mounting (incl. gasket) 		-	C146 30F003 000 4	
Anbaugehäuse (incl. Flachdichtung) Housing bulkhead end mounting (incl. gasket) 		-	C146 30F003 004 4	
Sockelgehäuse, 1 Kabelausgang Housing, single side entry 		20	C146 30N003 500 4	C146 31N003 500 4
Kupplungsgehäuse, 1 Kabelausgang Hood, cable to cable coupling 		20	C146 30R003 804 4	
Schutzkappen / Protective cover				
Schutzkappe für Gehäuseunterteile (nur in Verbindung mit Stifteinsatz) Cover for housings (only in connection with male insert) 		-	C146 30Z003 100 4	

**C 146 D 15 pol.
C 146 A 10 pol.**

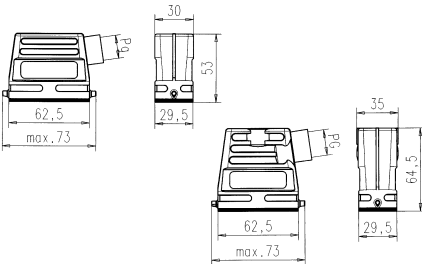
nach
DIN EN 175 301 - 801 (DIN 43 652)

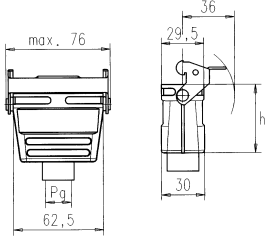
**Gehäuse
Housings**

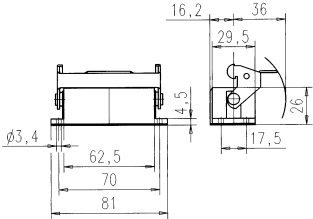
**PG-Gewinde
PG-thread**

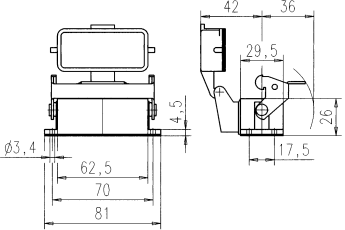
Bezeichnung - Abbildung Description - Figure	Maßzeichnung Drawing	PG	Bestell Nr. / Part No.		
			Niedrige Bauform/ Low profile	Hohe Bauform/ High profile	
Gehäuseoberteile / Hoods					
Tüllengehäuse, Abgang oben Hood, top entry 		13,5	C146 10G010 600 4		
		16	C146 10G010 601 4		
		16		C146 10G015 601 2	
		21		C146 10G015 600 2	
Tüllengehäuse, Abgang Seite Hood, side entry 		13,5	C146 10G010 501 4		
		16	C146 10G010 500 4		
		16		C146 10G015 501 2	
		21		C146 10G015 500 2	
Gehäuseunterteile / Housings					
Kupplungsgehäuse Hood, coupling application 		47,5	13,5	C146 10G010 804 4	
		47,5	16	C146 10G010 805 4	
		59	21		C146 10G015 804 2
Anbaugehäuse ¹⁾ Housing, bulkhead mounting 				C146 10F015 000 2	
Anbaugehäuse, mit Klappdeckel ¹⁾ Housing, bulkhead mounting, with spring cover 				C146 10F015 003 2	

¹⁾ incl. Flachdichtung / incl. gasket

Metrisches Gewinde
Metric thread



Maßzeichnung Drawing	M	Bestell Nr. / Part No.		Bestell Nr. / Part No.		
		Niedrige Bauform/ Low profile	Hohe Bauform/ High profile	Niedrige Bauform/ Low profile	Hohe Bauform/ High profile	
		mit Stutzen / with stud		ohne Stutzen / without stud		
	20	C146 10R010 650 4		C146 21R010 650 4		
	25	C146 10R010 600 4		C146 21R010 600 4		
	20		C146 10R015 650 2		C146 21R015 650 2	
	25		C146 10R015 600 2		C146 21R015 600 2	
	20			C146 10R015 650 2		C146 21R015 650 2
	25			C146 10R015 600 2		C146 21R015 600 2
	20	C146 10R010 550 4		C146 21R010 550 4		
	25	C146 10R010 500 4		C146 21R010 500 4		
	20		C146 10R015 550 2		C146 21R015 550 2	
	25		C146 10R015 500 2		C146 21R015 500 2	
	20			C146 10R015 550 2		C146 21R015 550 2
	25			C146 10R015 500 2		C146 21R015 500 2
	47,5	20	C146 10R010 854 4		C146 21R010 854 4	
	47,5	25	C146 10R010 804 4		C146 21R010 804 4	
	59	20		C146 10R015 854 2		C146 21R015 854 2
	59	25		C146 10R015 804 2		C146 21R015 804 2
	59	20				C146 21R015 854 2
	59	25				C146 21R015 804 2
			C146 10F015 000 2			
			C146 10F015 003 2			

C 146 D 15 pol.
C 146 A 10 pol.

nach
DIN EN 175 301 - 801 (DIN 43 652)

Gehäuse
Housings

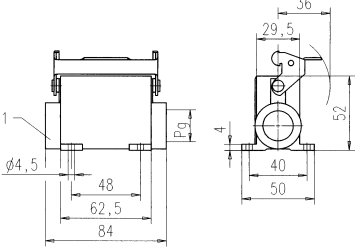
PG-Gewinde
PG-thread

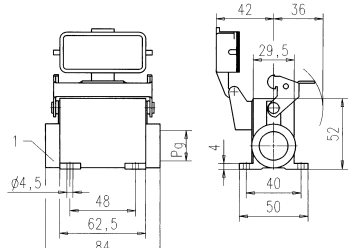
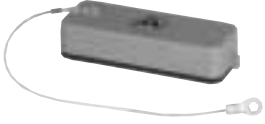
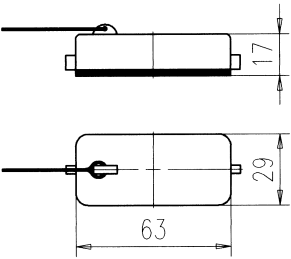
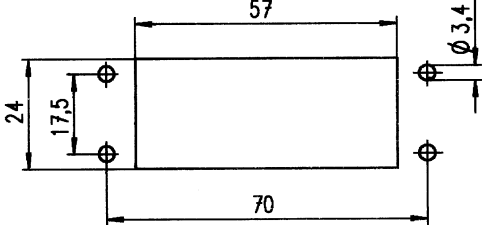
Bezeichnung - Abbildung Description - Figure	Maßzeichnung Drawing	PG	Bestell Nr. / Part No.	
			1 Kabelabgang single side entry	2 Kabelabgänge double side entry
Gehäuseunterteil / Housings				
Sockelgehäuse Housing 	 <p>1 Geschlossen bei einem Kabelausgang 1 closed if single entry</p>	16	C146 10F015 501 2	C146 10F015 601 2
		21	C146 10F015 500 2	C146 10F015 600 2
Sockelgehäuse mit Klappdeckel Housing with spring cover 	 <p>1 Geschlossen bei einem Kabelausgang 1 closed if single entry</p>	16	C146 10F015 807 2	C146 10F015 607 2
		21	C146 10F015 806 2	C146 10F015 606 2
Schutzkappen / Protective cover				
Schutzkappe für Gehäuseunterteile Cover for housings 		-	C146 10Z015 100 2	
Montageausschnitt / Panel cut out				
				

Verschraubung für Tüllen- und Sockelgehäuse siehe Seite 180-183 / gland bushings for hoods and housing see page 180-183

Zubehör siehe Seite 184-186 / accessories see page 184-186

Bei Sockelgehäusen Abgang rechts dargestellt / housings are shown with right outlet

according to
DIN EN 175 301 - 801 (DIN 43 652)

Metrisches Gewinde
Metric thread

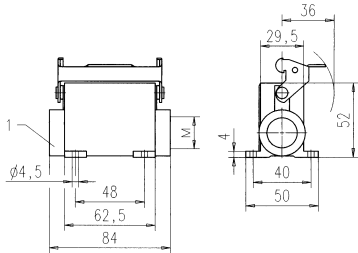
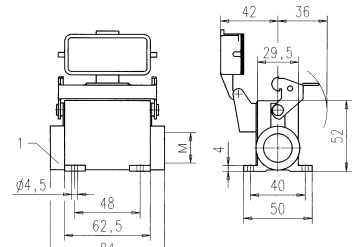
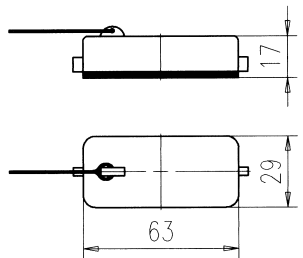
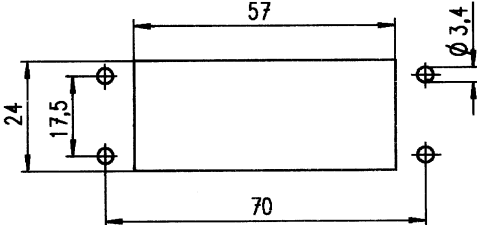





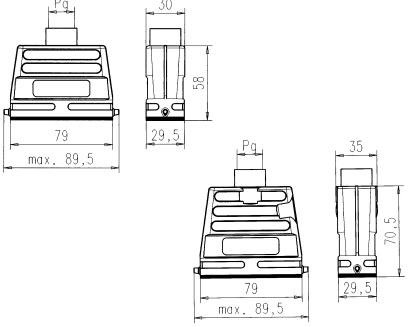

Maßzeichnung <i>Drawing</i>	M	Bestell Nr. / Part No.		
		1 Kabelabgang <i>single side entry</i>	2 Kabelabgänge <i>double side entry</i>	2 Kabelabgänge (rechts + unten) <i>double side entry (right + bottom)</i>
 <p>1 Geschlossen bei einem Kabelausgang <i>1 closed if single entry</i></p>	20 20 20 25 25 25	C146 10N015 501 2 C146 10N015 500 2	C146 10N015 601 2 C146 10N015 600 2	C146 10N015 703 2 C146 10N015 702 2
 <p>1 Geschlossen bei einem Kabelausgang <i>1 closed if single entry</i></p>	20 20 20 25 25 25	C146 10N015 807 2 C146 10N015 806 2	C146 10N015 607 2 C146 10N015 606 2	C146 10N015 709 2 C146 10N015 708 2
	-		C146 10Z015 100 2	
				

C 146 D 25 pol.
C 146 A 16 pol.

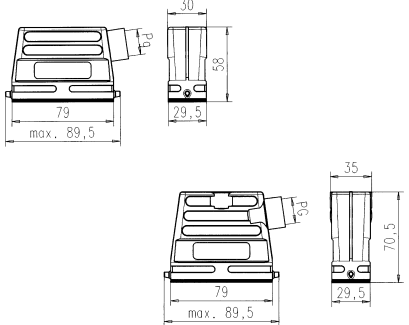
nach
DIN EN 175 301 - 801 (DIN 43 652)

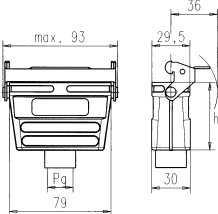
Gehäuse
Housings

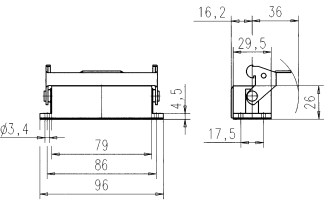
PG-Gewinde
PG-thread

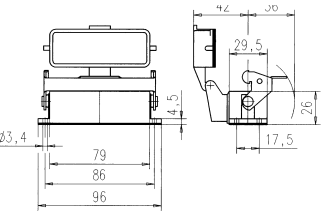
Bezeichnung - Abbildung Description - Figure	Maßzeichnung Drawing	PG	Bestell Nr. / Part No.	
			Niedrige Bauform/ Low profile	Hohe Bauform/ High profile
Gehäuseoberteile / Hoods				
Tüllengehäuse, Abgang oben Hood, top entry 		16	C146 10G016 600 4	
		16		C146 10G025 601 2
		21		C146 10G025 600 2
Tüllengehäuse, Abgang Seite Hood, side entry 		13,5	C146 10G016 501 4	
		16	C146 10G016 500 4	
		16		C146 10G025 501 2
		21		C146 10G025 500 2
Gehäuseunterteile / Housings				
Kupplungsgehäuse Hood, coupling application 		h		
		52,5	13,5	C146 10G016 805 4
		52,5	16	C146 10G016 804 4
		65	21	C146 10G025 804 2
Anbaugehäuse ¹⁾ Housing, bulkhead mounting 		-		C146 10F025 000 2
Anbaugehäuse, mit Klappdeckel ¹⁾ Housing, bulkhead mounting, with spring cover 		-		C146 10F025 003 2

¹⁾ incl. Flachdichtung / incl. gasket

Metrisches Gewinde
Metric thread



Maßzeichnung Drawing	M	Bestell Nr. / Part No.		Bestell Nr. / Part No.		
		Niedrige Bauform/ Low profile	Hohe Bauform/ High profile	Niedrige Bauform/ Low profile	Hohe Bauform/ High profile	
		mit Stutzen / with stud		ohne Stutzen / without stud		
	20	C146 10R016 650 4		C146 21R016 650 4		
	25	C146 10R016 600 4		C146 21R016 600 4		
	20		C146 10R025 650 2		C146 21R025 650 2	
	25		C146 10R025 600 2		C146 21R025 600 2	
	20	C146 10R016 550 4		C146 21R016 550 4		
	25	C146 10R016 500 4		C146 21R016 500 4		
	20		C146 10R025 550 2		C146 21R025 550 2	
	25		C146 10R025 500 2		C146 21R025 500 2	
	52,5	20	C146 10R016 854 4		C146 21R016 854 4	
	65	25	C146 10R016 804 4		C146 21R016 804 4	
	52,5	20		C146 10R025 854 2		C146 21R025 854 2
	65	25		C146 10R025 804 2		C146 21R025 804 2
		—	C146 10F025 000 2			
		—	C146 10F025 003 2			

C 146 D 25 pol.
C 146 A 16 pol.

nach
DIN 43 652 (CECC 75 301 - 801; EN 175 301 - 801)

Gehäuse
Housings

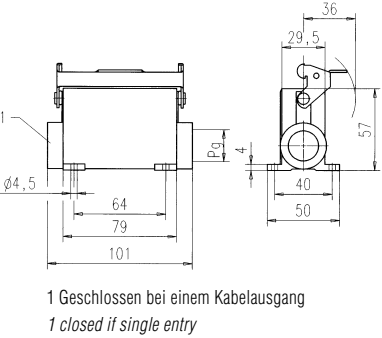
PG-Gewinde
PG-thread

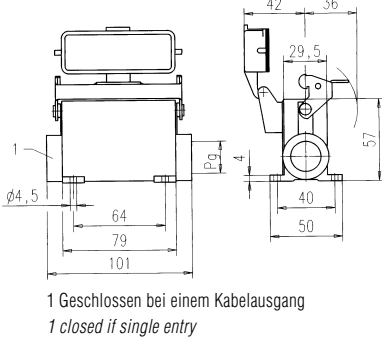
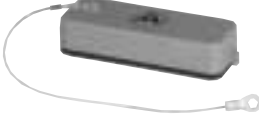
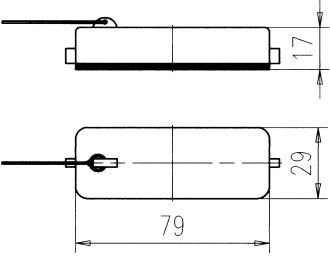
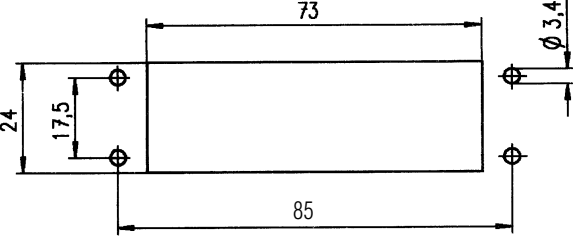
Bezeichnung - Abbildung Description - Figure	Maßzeichnung Drawing	PG	Bestell Nr. / Part No.	
			1 Kabelabgang single side entry	2 Kabelabgänge double side entry
Gehäuseunterteil / Housings				
Sockelgehäuse Housing 		16	C146 10F025 501 2	C146 10F025 601 2
		21	C146 10F025 500 2	C146 10F025 600 2
Sockelgehäuse mit Klappdeckel Housing with spring cover 		16	C146 10F025 807 2	C146 10F025 607 2
		21	C146 10F025 806 2	C146 10F025 606 2
Schutzkappen / Protective cover				
Schutzkappe für Gehäuseunterteile Cover for housings 		-	C146 10Z025 100 2	
Montageausschnitt / Panel cut out				
				

PG Verschraubung für Tüllen- und Sockelgehäuse siehe Seite 180-183 / PG gland bushings for hoods and housing see page 180-183

Zubehör siehe Seite 184-186 / accessories see page 184-186

Bei Sockelgehäusen Abgang rechts dargestellt / housings are shown with right outlet



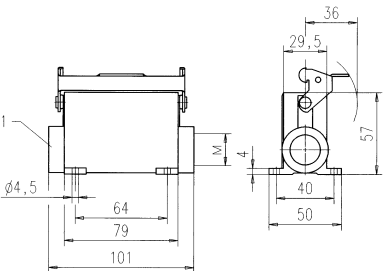
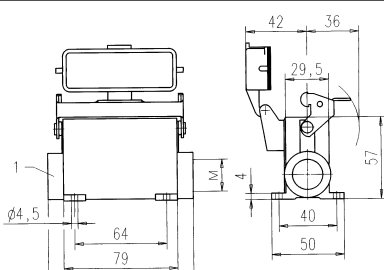
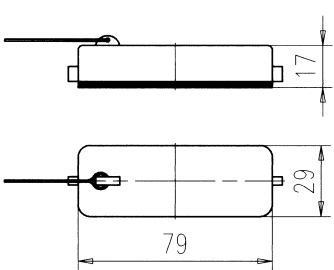
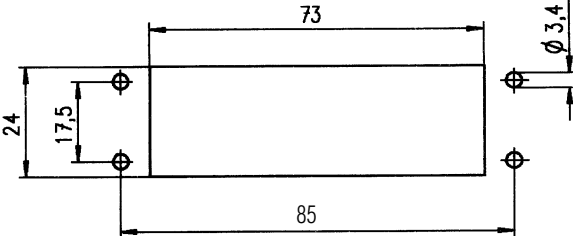



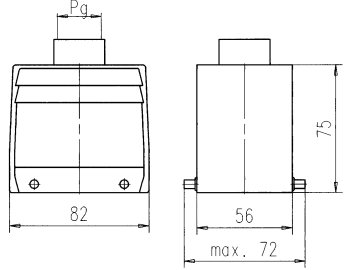

Metrisches Gewinde
Metric thread

Maßzeichnung Drawing	M	Bestell Nr. / Part No.			
		1 Kabelabgang single side entry	2 Kabelabgänge double side entry	2 Kabelabgänge (rechts + unten) double side entry (right + bottom)	
 <p>1 Geschlossen bei einem Kabelausgang 1 closed if single entry</p>	20	C146 10N025 501 2	C146 10N025 601 2	C146 10N025 703 2	
	20				
	20				
		25	C146 10N025 500 2	C146 10N025 600 2	C146 10N025 702 2
	25				
	25				
 <p>1 Geschlossen bei einem Kabelausgang 1 closed if single entry</p>	20	C146 10N025 807 2	C146 10N025 607 2	C146 10N025 709 2	
	20				
	20				
		25	C146 10N025 806 2	C146 10N025 606 2	C146 10N025 708 2
	25				
	25				
	—	C146 10Z025 100 2			
					

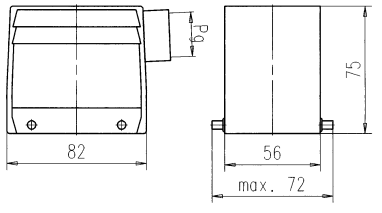
C 146 D 50 pol.
C 146 A 32 pol.

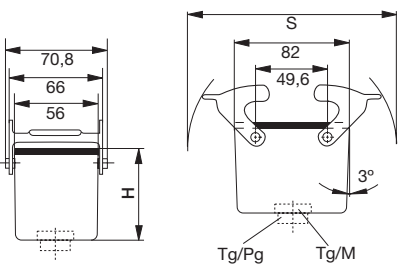
Gehäuse
Housings

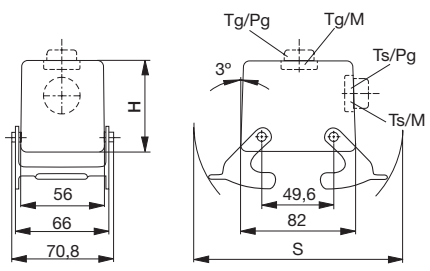
PG-Gewinde
PG-thread

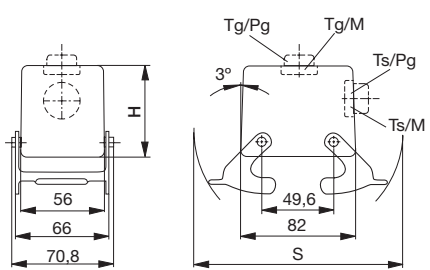





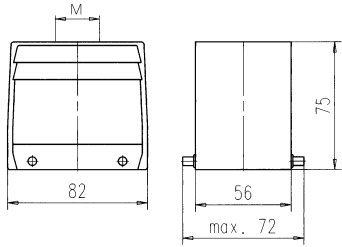

Bezeichnung - Abbildung Description - Figure	Maßzeichnung Drawing	PG	Bestell Nr. Part No.
Gehäuseoberteile / Hoods			
Tüllengehäuse, Abgang oben <i>Hood, top entry</i> 		21 29	C146 10G032 600 4 C146 10G032 601 4
Tüllengehäuse, Abgang Seite <i>Hood, side entry</i> 		21 29	C146 10G032 500 4 C146 10G032 501 4
Kupplungsgehäuse <i>Hood, coupling application</i> 			
Tüllengehäuse, Abgang oben <i>Hood, top entry</i> 			
Tüllengehäuse, Abgang Seite <i>Hood, side entry</i> 			

Verschraubung für Tüllen- und Sockelgehäuse siehe Seite 180-183 / gland bushings for hoods and housing see page 180-183
Zubehör siehe Seite 184-186 / accessories see page 184-186

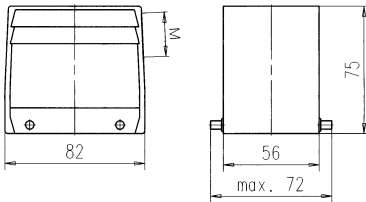
C 146 D 50 pol.
C 146 A 32 pol.

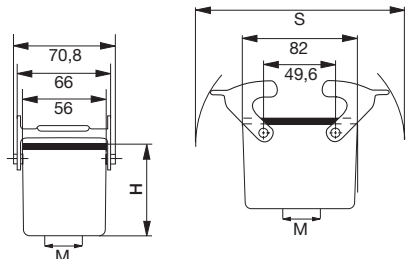
Gehäuse
Housings

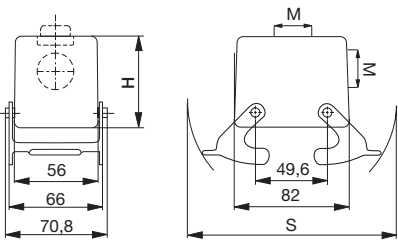
Metrisches Gewinde
Metric thread

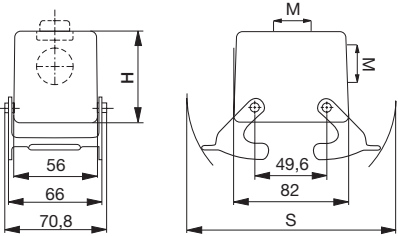
Bezeichnung - Abbildung Description - Figure	Maßzeichnung Drawing	M	Bestell Nr. Part No.
Gehäuseoberteile / Hoods		ohne Stutzen / without stud	
Tüllengehäuse, Abgang oben Hood, top entry 		25	C146 21R032 650 4
		32	C146 21R032 600 4
		40	C146 21R032 601 4
Tüllengehäuse, Abgang Seite Hood, side entry 		25	C146 21R032 550 4
		32	C146 21R032 500 4
		40	C146 21R032 501 4
Kupplungsgehäuse Hood, coupling application 		25	C146 21R032 852 4
		32	C146 21R032 802 4
		40	C146 21R032 803 4
Tüllengehäuse, Abgang oben Hood, top entry 		25	C146 21R032 652 4
		32	C146 21R032 602 4
		40	C146 21R032 603 4
Tüllengehäuse, Abgang Seite Hood, side entry 		25	C146 21R032 552 4
		32	C146 21R032 502 4
		40	C146 21R032 503 4

C 146 D 50 pol.
C 146 A 32 pol.

Gehäuse
Housings

PG-Gewinde
PG-thread

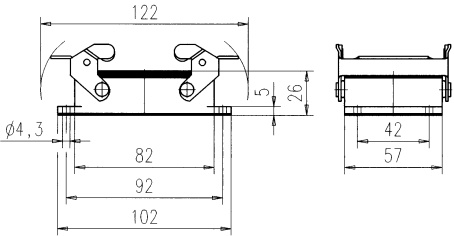
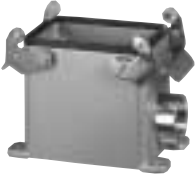
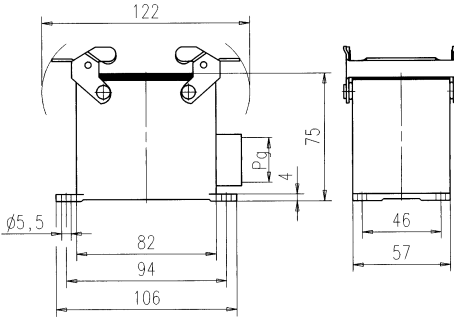
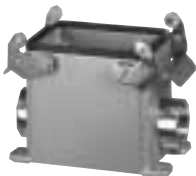
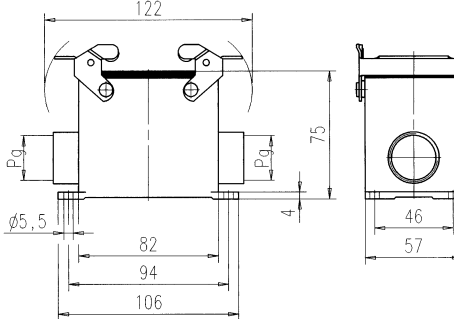
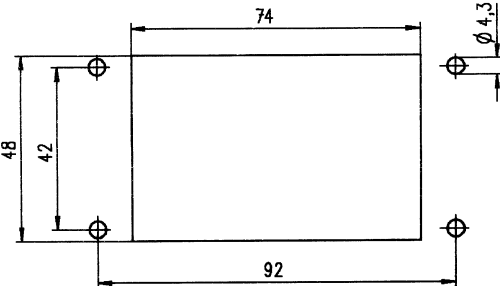
Bezeichnung - Abbildung Description - Figure	Maßzeichnung Drawing	PG	Bestell Nr. Part No.
Gehäuseunterteile / Housings			
Anbaugehäuse ¹⁾ Housing, bulkhead mounting 		-	C146 10F032 000 4
Anbaugehäuse ¹⁾ mit Bolzen und Klappdeckel Housing ¹⁾ , bulkhead mounting and with spring cover		-	C146 10F032 002 4
Sockelgehäuse, 1 Kabelabgang Housing, single side entry 		21 29	C146 10F032 500 4 C146 10F032 501 4
Sockelgehäuse, 2 Kabelabgänge Housing, double side entry 		21 29	C146 10F032 600 4 C146 10F032 601 4
Montageausschnitt / Panel cut out			
			







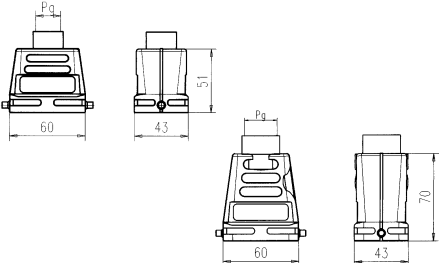

¹⁾ incl. Flachdichtung / incl. gasket
Bei Sockelgehäusen Abgang rechts dargestellt / housings are shown with right outlet

C 146 E 6 pol.
 C 146 M 2 Module
 C 146 DD 24 pol.
 C 146 EE 10 pol.

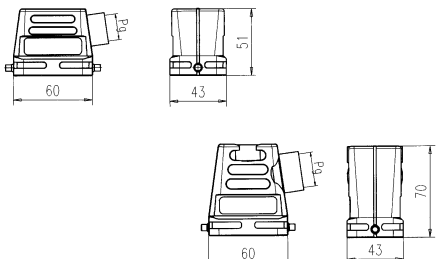
Gehäuse
 Housings

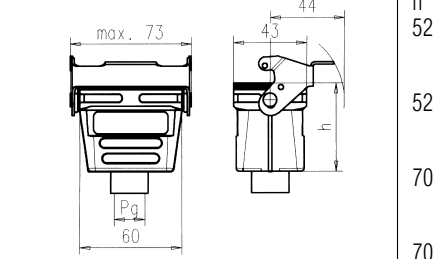
Gehäuse für Längsbügelverriegelung
 in Anlehnung an
 DIN EN 175 301 - 801 (DIN 43 652)

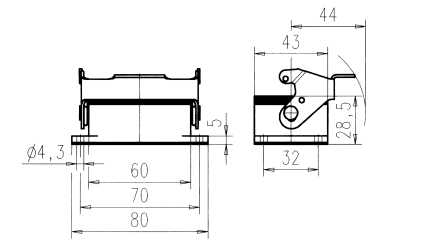
PG-Gewinde
 PG-thread

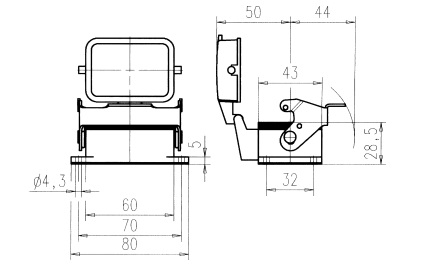
Bezeichnung - Abbildung Description - Figure	Maßzeichnung Drawing	PG	Bestell Nr. / Part No.		
			Niedrige Bauform / Low profile	Hohe Bauform / High profile	
Gehäuseoberteile / Hoods					
Tüllengehäuse, Abgang oben <i>Hood, top entry</i> 		13,5	C146 10G006 600 1		
		16	C146 10G006 601 1		
		16		C146 10G006 656 8	
		21		C146 10G006 606 8	
		29		C146 10G006 607 8	
Tüllengehäuse, Abgang Seite <i>Hood, side entry</i> 		13,5	C146 10G006 500 1		
		16	C146 10G006 501 1		
		16		C146 10G006 556 8	
		21		C146 10G006 506 8	
		29		C146 10G006 507 8	
Gehäuseunterteile / Housings					
Kupplungsgehäuse, <i>Hood, coupling application</i> 		h 52	13,5	C146 10G006 804 1	
		52	16	C146 10G006 805 1	
		70	21		C146 10G006 804 8
		70	29		C146 10G006 805 8
Anbaugehäuse ¹⁾ <i>Housing, bulkhead mounting ¹⁾</i> 		-			C146 10F006 000 1
Anbaugehäuse mit Klappdeckel ¹⁾ <i>Housing, bulkhead mounting with spring cover ¹⁾</i> 		-			C146 10F006 003 1

¹⁾incl. Flachdichtung / incl. gasket

housings for 1 locking-lever-system
 in accordance with
 DIN EN 175 301 - 801 (DIN 43 652)

Metrisches Gewinde
 Metric thread

Maßzeichnung Drawing	M	Bestell Nr. / Part No.		Bestell Nr. / Part No.	
		Niedrige Bauform/ Low profile	Hohe Bauform/ High profile	Niedrige Bauform/ Low profile	Hohe Bauform/ High profile
		mit Stutzen / with stud		ohne Stutzen / without stud	
	16	C146 10R006 656 1		C146 21R006 656 1	
	20	C146 10R006 606 1		C146 21R006 606 1	
	25	C146 10R006 607 1		C146 21R006 607 1	
	25		C146 10R006 656 8		C146 21R006 656 8
	32		C146 10R006 606 8		C146 21R006 606 8
	20	C146 10R006 506 1		C146 21R006 506 1	
	25	C146 10R006 507 1		C146 21R006 507 1	
	25		C146 10R006 556 8		C146 21R006 556 8
	32		C146 10R006 506 8		C146 21R006 506 8
	20	C146 10R006 804 1		C146 21R006 804 1	
	25	C146 10R006 805 1		C146 21R006 805 1	
	25		C146 10R006 854 8		C146 21R006 854 8
	32		C146 10R006 804 8		C146 21R006 804 8
	—	C146 10F006 000 1			
	—	C146 10F006 003 1			

housings for 1 locking-lever-system
 in accordance with
 DIN EN 175 301 - 801 (DIN 43 652)

Metrisches Gewinde
 Metric thread

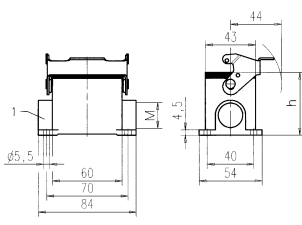
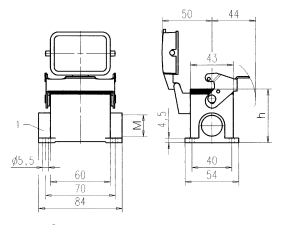
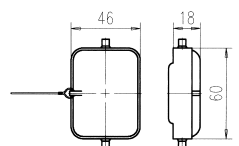
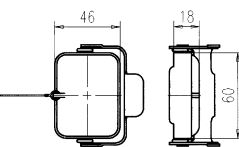
Maßzeichnung Drawing	M	Bestell Nr. / Part No.		Bestell Nr. / Part No.		
		Niedrige Bauform/ Low profile	Hohe Bauform/ High profile	Niedrige Bauform/ Low profile	Hohe Bauform/ High profile	
		1 Kabelabgang		2 Kabelabgänge		
 <p>1 Geschlossen bei einem Kabelausgang 1 closed if single entry</p>	h					
	54	20	C146 10N006 803 1		C146 10N006 603 1	
	54	20	C146 10N006 503 1 ^(L)		C146 10N006 703 1 ^(R+U)	
	54/74	25	C146 10N006 802 1	C146 10N006 803 2	C146 10N006 602 1	C146 10N006 603 2
	54/74	25	C146 10N006 502 1 ^(L)	C146 10N006 503 2 ^(L)	C146 10N006 702 1 ^(R+U)	
	74	32		C146 10N006 802 2		C146 10N006 602 2
74	32		C146 10N006 502 2 ^(L)			
 <p>1 Geschlossen bei einem Kabelausgang 1 closed if single entry</p>	54	20	C146 10N006 807 1		C146 10N006 607 1	
	54	20	C146 10N006 507 1 ^(L)		C146 10N006 709 1 ^(R+U)	
	54/74	25	C146 10N006 806 1	C146 10N006 807 2	C146 10N006 606 1	C146 10N006 607 2
	54/74	25	C146 10N006 506 1 ^(L)	C146 10N006 507 2 ^(L)	C146 10N006 708 1 ^(R+U)	
	74	32		C146 10N006 806 2		C146 10N006 606 2
	74	32		C146 10N006 506 2 ^(L)		
	-		C146 10Z006 100 1			
		-		C146 10Z006 200 1		

^(R+U) rechts und unten / right and bottom
^(L) links / left







C 146 E 10 pol.
C 146 M 3 Module
C 146 DD 42 pol.
C 146 HvE 3 pol.
C 146 EE 18 pol.

Gehäuse
Housings

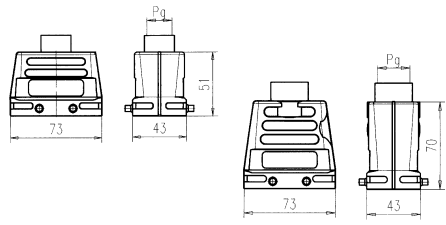
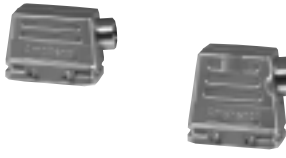
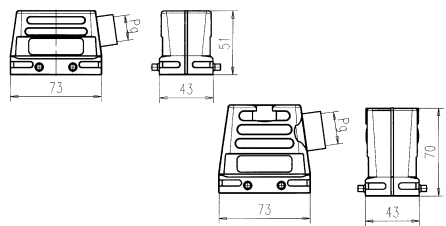
Gehäuse für Querbügelverriegelung
in Anlehnung an
DIN EN 175 301 - 801 (DIN 43 652)

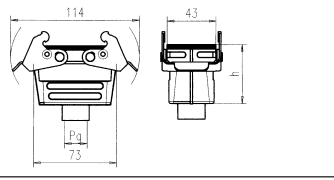
- sichere 4-Punkt Verriegelung
- bevorzugt bei seitlicher Anreihung
- fliegende Verbindung möglich

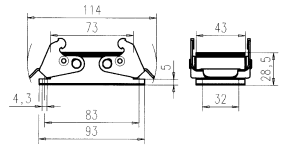
PG-Gewinde
PG-thread

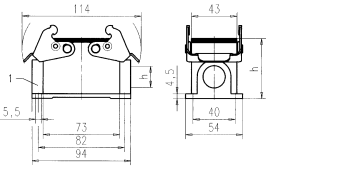
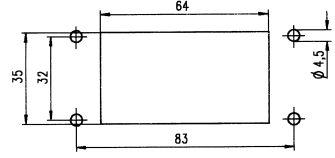
Bezeichnung - Abbildung Description - Figure	Maßzeichnung Drawing	PG	Bestell Nr. / Part No. Niedrige Bauform / Low profile Hohe Bauform / High profile		
Gehäuseoberteile / Hoods					
Tüllengehäuse, Abgang oben Hood, top entry 		16	C146 10G010 600 1		
		21	C146 10G010 601 1		
		16		C146 10G010 650 8	
		21		C146 10G010 600 8	
		29		C146 10G010 601 8	
Tüllengehäuse, Abgang Seite Hood, side entry 		16	C146 10G010 500 1		
		21	C146 10G010 501 1		
		16		C146 10G010 550 8	
		21		C146 10G010 500 8	
		29		C146 10G010 501 8	
Gehäuseunterteile / Housings					
Kupplungsgehäuse Hood, coupling application 		h 51 51/70	16 21 29	C146 10G010 802 1 C146 10G010 803 1 C146 10G010 802 8 C146 10G010 803 8	
Anbaugehäuse ¹⁾ Housing, bulkhead mounting ¹⁾ 			-	C146 10F010 000 1	
Winkelanbaugehäuse ¹⁾ Right-angled housing ¹⁾ 			-	C146 10F010 090 1	
Sockelgehäuse Housing 		h 57 74 74	16	1 Kabelabgang / single side entry	
			21	C146 10F010 500 1	C146 10F010 501 2 C146 10F010 500 2
			29	2 Kabelabgänge / Double side entry	
			16	C146 10F010 600 1	C146 10F010 601 2 C146 10F010 600 2
			21 29		
Montageausschnitt für Anbaugehäuse / Panel cut out for housing bulkhead mounting					
					

Verschraubung für Tüllen- und Sockelgehäuse siehe Seite 180-183 / gland bushings for hoods and housing see page 180-183

Zubehör siehe Seite 184-186 / accessories see page 184-186

¹⁾ incl. Flachdichtung / incl. gasket

**housings for 2 locking-lever-system
 according to DIN EN 175 301 - 801
 (DIN 43 652)**

- secured 4 point locking
- preferred for side by side mounting
- cable to cable possible

**Metrisches Gewinde
 Metric thread**

Maßzeichnung Drawing	M	Bestell Nr. / Part No.		Bestell Nr. / Part No.		
		Niedrige Bauform/ Low profile	Hohe Bauform/ High profile	Niedrige Bauform/ Low profile	Hohe Bauform/ High profile	
			mit Stutzen / with stud		ohne Stutzen / without stud	
	20	C146 10R010 650 1		C146 21R010 650 1		
	25	C146 10R010 600 1		C146 21R010 600 1		
	25		C146 10R010 650 8		C146 21R010 650 8	
	32		C146 10R010 600 8		C146 21R010 600 8	
	40		C146 10R010 601 8		C146 21R010 601 8	
	20	C146 10R010 550 1		C146 21R010 550 1		
	25	C146 10R010 500 1		C146 21R010 500 1		
	25		C146 10R010 550 8		C146 21R010 550 8	
	32		C146 10R010 500 8		C146 21R010 500 8	
	h					
	51	C146 10R010 852 1		C146 21R010 852 1		
	51/70	C146 10R010 802 1	C146 10R010 852 8	C146 21R010 802 1	C146 21R010 852 8	
	51/70	C146 10R010 803 1	C146 10R010 802 8	C146 21R010 803 1	C146 21R010 802 8	
	70		C146 10R010 803 8		C146 21R010 803 8	
	-	C146 10F010 000 1				
	-	C146 10F010 090 1				
<p>1.) Verschlusschraube bei einem Kabelausgang 1.) Screwed sealing plug if single entry</p>	h	1 Kabelabgang / single side entry		2 Kabelabgänge / Double side entry		
	57	20	C146 10N010 501 1		C146 10N010 601 1	
	57	20			C146 10N010 701 1 ^(r+u)	
	57/74	25	C146 10N010 500 1	C146 10N010 501 2	C146 10N010 600 1	C146 10N010 601 2
	57	25			C146 10N010 700 1 ^(r+u)	
74	32		C146 10N010 500 2		C146 10N010 600 2	

^(r+u) rechts und unten / right and bottom







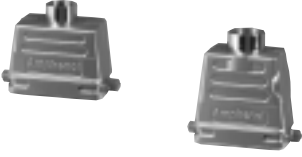
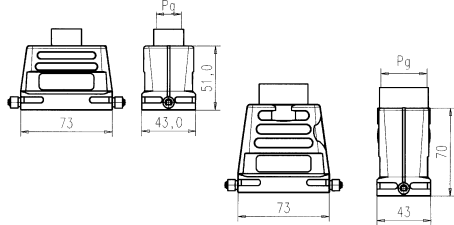
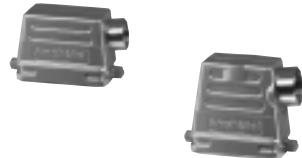
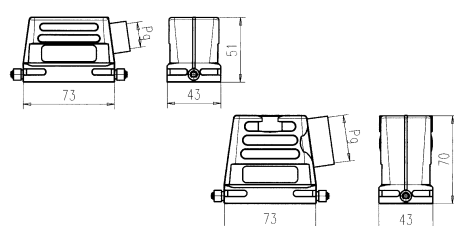
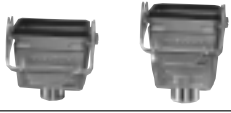
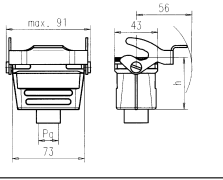

C 146 E 10 pol.
C 146 M 3 Module
C 146 DD 42 pol.
C 146 HvE 3 pol.
C 146 EE 18 pol.

Gehäuse
Housings

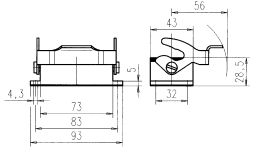
Gehäuse für Längsbügelverriegelung
in Anlehnung an
DIN EN 175 301 - 801 (DIN 43 652)

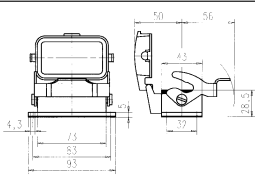
- leichtes Bedienen auch bei seitlichem Kabelabgang
- Schutzkappe am Gehäuseunterteil verriegelbar
- fliegende Verbindung möglich

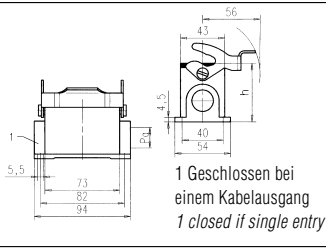
PG-Gewinde
PG-thread

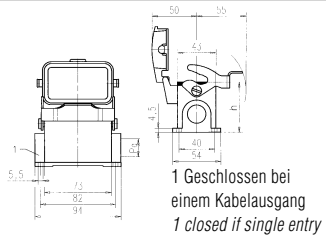
Bezeichnung - Abbildung Description - Figure	Maßzeichnung Drawing	PG	Bestell Nr. / Part No.		
			Niedrige Bauform / Low profile	Hohe Bauform / High profile	
Gehäuseoberteile / Hoods					
Tüllengehäuse, Abgang oben Hood, top entry 		16	C146 10G010 606 1		
		21	C146 10G010 607 1		
		21		C146 10G010 606 8	
		29		C146 10G010 607 8	
Tüllengehäuse, Abgang Seite Hood, side entry 		16	C146 10G010 506 1		
		21	C146 10G010 507 1		
		21		C146 10G010 506 8	
		29		C146 10G010 507 8	
Gehäuseunterteile / Housings					
Kupplungsgehäuse Hood, coupling application 		h			
		51	16	C146 10G010 804 1	
		51/70	21	C146 10G010 805 1	C146 10G010 804 8
		70	29	C146 10G010 805 8	
Anbaugehäuse ¹⁾ Housing, bulkhead mounting ¹⁾ 				C146 10F010 001 1	
Anbaugehäuse mit Deckel ¹⁾ Housing with spring cover ¹⁾ 				C146 10F010 003 1	
Sockelgehäuse Housing 		h	1 Kabelabgang / Single side entry		
		57	C146 10F010 802 1	C146 10F010 803 2	
		57/74	C146 10F010 502 1 ^(*)	C146 10F010 503 2 ^(*)	
		74		C146 10F010 802 2	
		74		C146 10F010 802 2	
		74		C146 10F010 502 2 ^(*)	
			2 Kabelabgänge / Double side entry		
		57	C146 10F010 602 1	C146 10F010 603 2	
		74		C146 10F010 602 2	
		74		C146 10F010 602 2	
Sockelgehäuse mit Deckel Housing with spring cover 		h	1 Kabelabgang / Single side entry		
		57	C146 10F010 806 1	C146 10F010 807 2	
		57/74	C146 10F010 506 1 ^(*)	C146 10F010 507 2 ^(*)	
		74		C146 10F010 806 2	
		74		C146 10F010 806 2	
		74		C146 10F010 506 2 ^(*)	
			2 Kabelabgänge / Double side entry		
		57	C146 10F010 606 1	C146 10F010 607 2	
		74		C146 10F010 606 2	
		74		C146 10F010 606 2	

¹⁾incl. Flachdichtung / incl. flat sealing

^(*) links / left

Bei Sockelgehäusen Abgang rechts dargestellt / housings are shown with right outlet

**housings for 1 locking-lever-system
 in accordance with
 DIN EN 175 301 - 801 (DIN 43 652)**

- also easy to use for side entry
- cover for housings lockable
- cable to cable possible

**Metrisches Gewinde
 Metric thread**

Maßzeichnung Drawing	M	Bestell Nr. / Part No.		Bestell Nr. / Part No.		
		Niedrige Bauform/ Low profile	Hohe Bauform/ High profile	Niedrige Bauform/ Low profile	Hohe Bauform/ High profile	
		mit Stutzen / with stud		ohne Stutzen / without stud		
	20	C146 10R010 656 1		C146 21R010 656 1		
	25	C146 10R010 606 1		C146 21R010 606 1		
	32	C146 10R010 607 1		C146 21R010 607 1		
	25		C146 10R010 656 8		C146 21R010 656 8	
	32		C146 10R010 606 8		C146 21R010 606 8	
	40		C146 10R010 607 8		C146 21R010 607 8	
	20	C146 10R010 556 1		C146 21R010 556 1		
	25	C146 10R010 506 1		C146 21R010 506 1		
	25		C146 10R010 556 8		C146 21R010 556 8	
	32		C146 10R010 506 8		C146 21R010 506 8	
	h 51	20	C146 10R010 854 1		C146 21R010 854 1	
	51/70	25	C146 10R010 804 1	C146 10R010 854 8	C146 21R010 804 1	C146 21R010 854 8
	51/70	32	C146 10R010 805 1	C146 10R010 804 8	C146 21R010 805 1	C146 21R010 804 8
	70	40		C146 10R010 805 8		C146 21R010 805 8
			C146 10F010 001 1			
			C146 10F010 003 1			
<p>1 Geschlossen bei einem Kabelausgang 1 closed if single entry</p>	h 57	20	1 Kabelabgang / Single side entry		2 Kabelabgänge / Double side entry	
	57	20	C146 10N010 803 1		C146 10N010 603 1	
	57/74	20	C146 10N010 503 1 (*)		C146 10N010 703 1 (r+u)	
	57/74	25	C146 10N010 802 1	C146 10N010 803 2	C146 10N010 602 1	C146 10N010 603 2
	74	25	C146 10N010 502 1 (*)	C146 10N010 503 2 (*)	C146 10N010 702 1 (r+u)	
	74	32		C146 10N010 802 2		C146 10N010 602 2
	74	32		C146 10N010 502 2 (*)		
<p>1 Geschlossen bei einem Kabelausgang 1 closed if single entry</p>	h 57	20	1 Kabelabgang / Single side entry		2 Kabelabgänge / Double side entry	
	57	20	C146 10N010 807 1		C146 10N010 607 1	
	57/74	20	C146 10N010 507 1 (*)		C146 10N010 708 1 (r+u)	
	57/74	25	C146 10N010 806 1	C146 10N010 807 2	C146 10N010 606 1	C146 10N010 607 2
	74	25	C146 10N010 506 1 (*)	C146 10N010 507 2 (*)	C146 10N010 709 1 (r+u)	
	74	32		C146 10N010 806 2		C146 10N010 606 2
	74	32		C146 10N010 506 2 (*)		

(*) links / left

(r+u) rechts und unten / right and bottom







C 146 E 10 pol.
 C 146 M 3 Module
 C 146 DD 42 pol.
 C 146 HvE 3 pol.
 C 146 EE 18 pol.

Gehäuse
 Housings

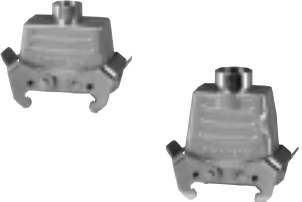
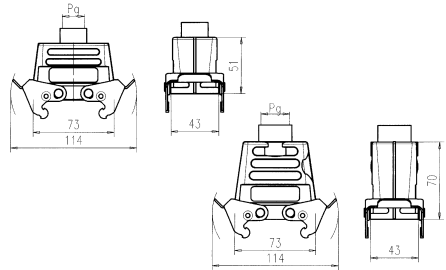
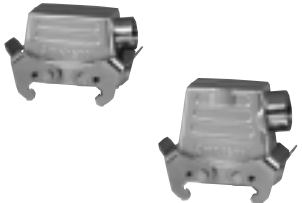
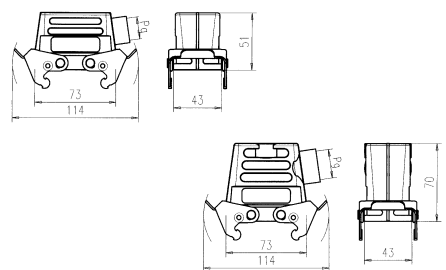
Tüllengehäuse mit Querbügel
 in Anlehnung an
 DIN EN 175 301 - 801 (DIN 43 653)

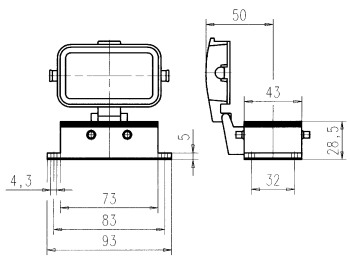
- sichere 4-Punkt Verriegelung
- Gehäuseunterteil mit Schutzdeckel
- keine Bügel am Gehäuseunterteil

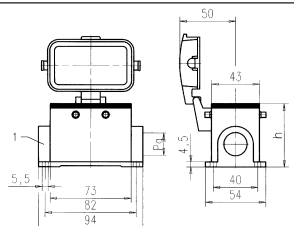
PG-Gewinde
 PG-thread

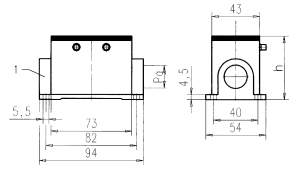
Bezeichnung - Abbildung Description - Figure	Maßzeichnung Drawing	PG	Bestell Nr. / Part No. Niedrige Bauform / Low profile Hohe Bauform / High profile	
Gehäuseoberteile / Hoods				
Tüllengehäuse, Abgang oben Hood, top entry 		16	C146 10G010 602 1	
		21	C146 10G010 603 1	
		21		C146 10G010 602 8
		29		C146 10G010 603 8
Tüllengehäuse, Abgang Seite Hood, side entry 		16	C146 10G010 502 1	
		21	C146 10G010 503 1	
		21		C146 10G010 502 8
		29		C146 10G010 503 8
Gehäuseunterteile / Housings				
Anbaugehäuse mit Deckel ¹⁾ Housing, with spring cover ¹⁾ 		-	C146 10F010 002 1	
Sockelgehäuse, mit Deckel Housing, with spring cover 			1 Kabelabgang / Single side entry	
		h 57	C146 10F010 804 1	C146 10F010 805 2
		16/21	C146 10F010 504 1 ^(*)	C146 10F010 505 2 ^(*)
		74		C146 10F010 804 2
			2 Kabelabgänge / Double side entry	
		57	C146 10F010 604 1	
	1 Geschlossen bei einem Kabelausgang 1 closed if single entry	74		C146 10F010 605 2
		74		C146 10F010 604 2
Sockelgehäuse Housing 			1 Kabelabgang / Single side entry	
		h 74		C146 10F010 509 2
		74		C146 10F010 508 2
				2 Kabelabgänge / Double side entry
		74		C146 10F010 609 2
	1 Geschlossen bei einem Kabelausgang 1 closed if single entry	74		C146 10F010 608 2

¹⁾incl. Flachdichtung / incl. gasket

Bei Sockelgehäusen Abgang rechts dargestellt / housings are shown with right outlet

**hoods with 2 locking-levers
in accordance with
DIN EN 175 301 - 801 (DIN 43 653)**

- secured 4 point locking
- housing with cover
- no locking levers at the housings

**Metrisches Gewinde
Metric thread**

Maßzeichnung Drawing	M	Bestell Nr. / Part No.		Bestell Nr. / Part No.		
		Niedrige Bauform/ Low profile	Hohe Bauform/ High profile	Niedrige Bauform/ Low profile	Hohe Bauform/ High profile	
		mit Stutzen / with stud		ohne Stutzen / without stud		
	20	C146 10R010 652 1		C146 21R010 652 1		
	25	C146 10R010 602 1		C146 21R010 602 1		
	25		C146 10R010 652 8		C146 21R010 652 8	
	32		C146 10R010 602 8		C146 21R010 602 8	
	40		C146 10R010 603 8		C146 21R010 603 8	
	20	C146 10R010 552 1		C146 21R010 552 1		
	25	C146 10R010 502 1		C146 21R010 502 1		
	25		C146 10R010 552 8		C146 21R010 552 8	
	32		C146 10R010 502 8		C146 21R010 502 8	
	C146 10F010 002 1					
<p>1 Geschlossen bei einem Kabelausgang 1 closed if single entry</p>	h	1 Kabelabgang / Single side entry		2 Kabelabgänge / Double side entry		
	57	20	C146 10N010 805 1		C146 10N010 605 1	
	57	20	C146 10N010 505 1 ^(*)		C146 10N010 809 1 ^(*)	
	57/74	25	C146 10N010 804 1	C146 10N010 805 2	C146 10N010 604 1	C146 10N010 605 2
	57/74	25	C146 10N010 504 1 ^(*)	C146 10N010 505 2 ^(*)	C146 10N010 808 1 ^(*)	
74	32		C146 10N010 804 2		C146 10N010 604 2	
74	32		C146 10N010 504 2 ^(*)			
<p>1 Geschlossen bei einem Kabelausgang 1 closed if single entry</p>	h	1 Kabelabgang / Single side entry		2 Kabelabgänge / Double side entry		
	57	20	C146 10N010 509 1		C146 10N010 609 1	
	57/74	25	C146 10N010 508 1	C146 10N010 509 2	C146 10N010 608 1	C146 10N010 609 2
74	32		C146 10N010 508 2		C146 10N010 608 2	

^(*) links / left

^(*) rechts und unten / right and bottom





C 146 E 10 pol.
 C 146 M 3 Module
 C 146 DD 42 pol.
 C 146 HvE 3 pol.
 C 146 EE 18 pol.

Gehäuse, Schutzkappen
 Housings, covers

Sondergehäuse für Querbügelverriegelung,
 in Anlehnung an
 DIN EN 175 301 - 801 (DIN 43 653)

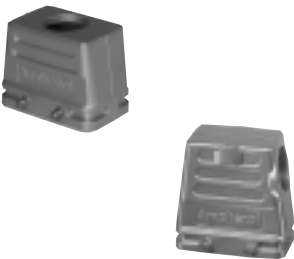
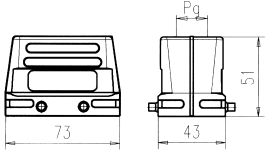
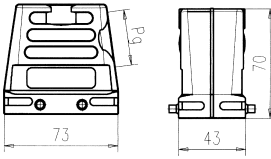
PG-Gewinde
 PG-thread

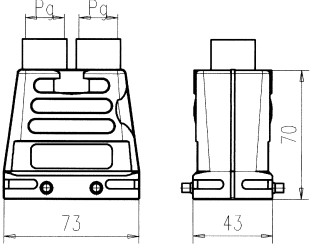
special housings for 2 locking-system,
 in accordance with
 DIN EN 175 301 - 801 (DIN 43 653)

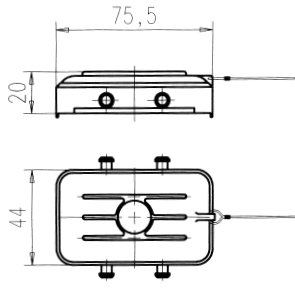
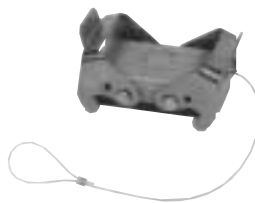
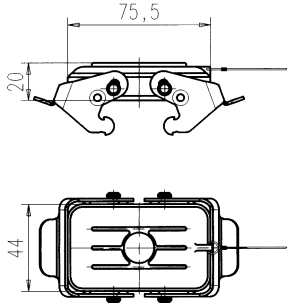
Bezeichnung - Abbildung Description - Figure	Maßzeichnung Drawing	PG	Kabelabgang cable outlet	Bestell Nr. / Part No.	
				Niedrige Bauform / Low profile	Hohe Bauform / High profile
Gehäuseoberteile / Hoods					
Tüllengehäuse ohne Stutzen Hood without stud 	 	16	Oben / top Seite / side	C146 21G010 600 1 C146 21G010 500 1	
		21	Oben / top Seite / side		C146 21G010 600 8 C146 21G010 500 8
Tüllengehäuse, 2 x Abgang Oben Hood, 2 top entry 		16			C146 10G010 902 8
Schutzkappen / Protective cover					
Schutzkappe für Gehäuseunterteile Cover for housings 		-		C146 10Z010 100 1	
Schutzkappe für Gehäuseoberteile Cover for hoods 		-		C146 10Z010 200 1	

Verschraubung für Tüllen- und Sockelgehäuse siehe Seite 180-183 / gland bushings for hoods and housing see page 180-183
 Zubehör siehe Seite 184-186 / accessories see page 184-186





C 146 E 10 pol.
 C 146 M 3 Module
 C 146 DD 42 pol.
 C 146 HvE 3 pol.
 C 146 EE 18 pol.

Gehäuse, Schutzkappen
 Housings, covers

Sondergehäuse für Querbügelverriegelung,
 in Anlehnung an
 DIN EN 175 301 - 801 (DIN 43 653)

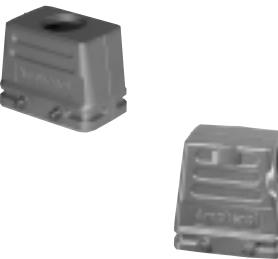
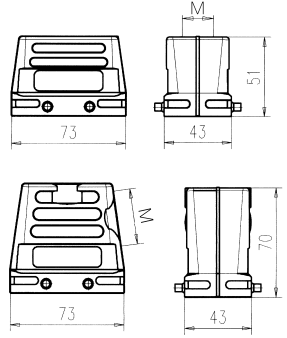
Metrisches Gewinde
 Metric thread

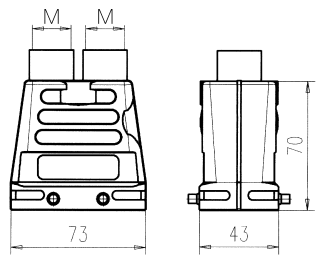
special housings for 2 locking-system,
 in accordance with
 DIN EN 175 301 - 801 (DIN 43 653)

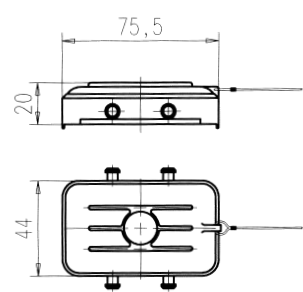
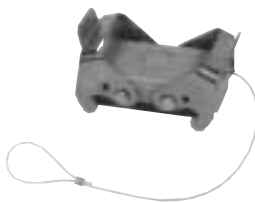
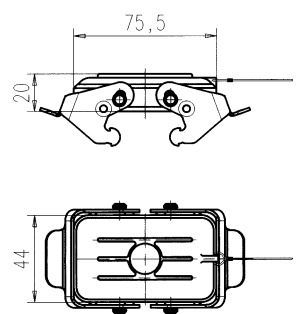
Bezeichnung - Abbildung Description - Figure	Maßzeichnung Drawing	M	Kabelabgang cable outlet	Bestell Nr. / Part No.	
Gehäuseoberteile / Hoods					
Niedrige Bauform / Low profile					
Hohe Bauform / High profile					
Tüllengehäuse ohne Stutzen Hood without stud 		20	Oben / top	C146 21R010 650 1	
		20	Seite / side	C146 21R010 550 1	
		25	Oben / top	C146 21R010 600 1	
		25	Seite / side	C146 21R010 500 1	
		25	Oben / top		C146 21R010 650 8
		25	Seite / side		C146 21R010 550 8
		32	Oben / top		C146 21R010 600 8
		32	Seite / side		C146 21R010 500 8
40	Oben / top		C146 21R010 601 8		
Tüllengehäuse, 2 x Abgang Oben Hood, 2 top entry 		25			C146 10R010 902 8
Schutzkappen / Protective cover					
Schutzkappe für Gehäuseunterteile Cover for housings 		-		C146 10Z010 100 1	
Schutzkappe für Gehäuseoberteile Cover for hoods 		-		C146 10Z010 200 1	







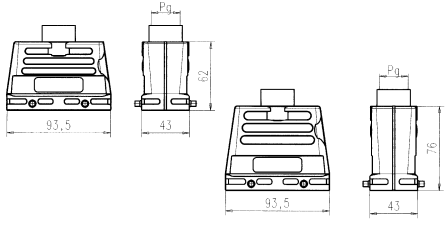

Verschraubung für Tüllen- und Sockelgehäuse siehe Seite 180-183 / gland bushings for hoods and housing see page 180-183
 Zubehör siehe Seite 184-186 / accessories see page 184-186

C 146 E 16 pol.
C 146 M 5 Module
C 146 D 40 pol.
C 146 DD 72 pol.
C 146 HSE 6 pol.
C 146 HvE 6 pol.
C 146 EE 32 pol.
 Gehäuse / Housings

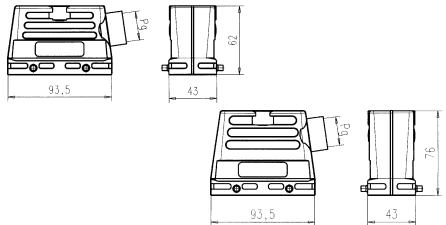
Gehäuse für Querbügelverriegelung nach
 DIN EN 175 301 - 801 (DIN 43 652)

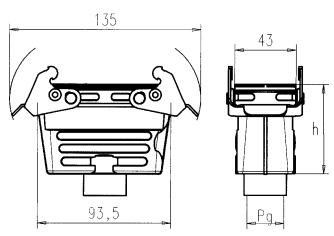
- sichere 4-Punkt Verriegelung
- bevorzugt bei seitlicher Anreihung
- fliegende Verbindung möglich

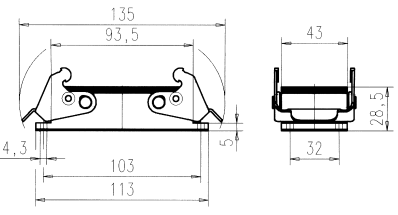
PG-Gewinde
PG-thread

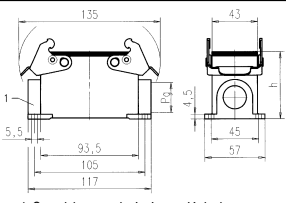
Bezeichnung - Abbildung Description - Figure	Maßzeichnung Drawing	PG	Bestell Nr. / Part No.	
			Niedrige Bauform / Low profile	Hohe Bauform / High profile
Gehäuseoberteile / Hoods				
Tüllengehäuse, Abgang oben <i>Hood, top entry</i> 		21	C146 10G016 600 1	
		29	C146 10G016 601 1	
		21		C146 10G016 600 8
		29		C146 10G016 601 8
Tüllengehäuse, Abgang Seite <i>Hood, side entry</i> 		21	C146 10G016 500 1	
		29	C146 10G016 501 1	
		21		C146 10G016 500 8
		29		C146 10G016 501 8
Gehäuseunterteile / Housings				
Kupplungsgehäuse <i>Hood, coupling application</i> 		21	C146 10G016 802 1	
		29	C146 10G016 803 1	
		21		C146 10G016 802 8
		29		C146 10G016 803 8
Anbaugehäuse ¹⁾ <i>Housing, bulkhead mounting ¹⁾</i> 		-	C146 10F016 000 1	
Sockelgehäuse <i>Housing</i> 	 <p>1 Geschlossen bei einem Kabelausgang 1 closed if single entry</p>		1 Kabelabgang / Single side entry	
		21	C146 10F016 500 1	C146 10F040 501 2
		29		C146 10F040 500 2
			2 Kabelabgänge / Double side entry	
		21	C146 10F016 600 1	C146 10F040 601 2
		29		C146 10F040 600 2

Montageausschnitt für Anbaugehäuse / Panel cut out for housing bulkhead mounting

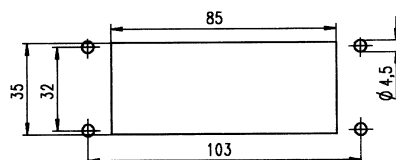

⁽¹⁾ links / left

**housings for 2 locking-lever-system according to
 DIN EN 175 301 - 801 (DIN 43 652)**

- **secured 4 point locking**
- **preferred for side by side mounting**
- **cable to cable possible**

**Metrisches Gewinde
Metric thread**

Maßzeichnung <i>Drawing</i>	M	Bestell Nr. / <i>Part No.</i>		Bestell Nr. / <i>Part No.</i>		
		Niedrige Bauform/ <i>Low profile</i>	Hohe Bauform/ <i>High profile</i>	Niedrige Bauform/ <i>Low profile</i>	Hohe Bauform/ <i>High profile</i>	
		mit Stützen / <i>with stud</i>		ohne Stützen / <i>without stud</i>		
	25	C146 10R016 650 1		C146 21R016 650 1		
	32	C146 10R016 600 1		C146 21R016 600 1		
	25		C146 10R016 650 8		C146 21R016 650 8	
	32		C146 10R016 600 8		C146 21R016 600 8	
	40		C146 10R016 601 8		C146 21R016 601 8	
		25	C146 10R016 550 1		C146 21R016 550 1	
		32	C146 10R016 500 1		C146 21R016 500 1	
		25		C146 10R016 550 8		C146 21R016 550 8
32			C146 10R016 500 8		C146 21R016 500 8	
40			C146 10R016 501 8		C146 21R016 501 8	
		h 25	C146 10R016 852 1		C146 21R016 852 1	
		h 32	C146 10R016 802 1		C146 21R016 802 1	
		h 25		C146 10R016 852 8		C146 21R016 852 8
	h 32		C146 10R016 802 8		C146 21R016 802 8	
	h 40		C146 10R016 803 8		C146 21R016 803 8	
	C146 10F016 000 1					
			1 Kabelabgang / <i>Single side entry</i>		2 Kabelabgänge / <i>Double side entry</i>	
<p>1 Geschlossen bei einem Kabelausgang <i>1 closed if single entry</i></p>	h 25	C146 10N016 500 1	C146 10N016 501 2	C146 10N016 600 1	C146 10N016 601 2	
	h 25			C146 10N016 700 1 ^(r+u)	C146 10N016 701 2 ^(r+u)	
	h 32		C146 10N016 500 2		C146 10N016 600 2	
	h 32				C146 10N016 700 2 ^(r+u)	

^(r+u) rechts und unten / *right and bottom*









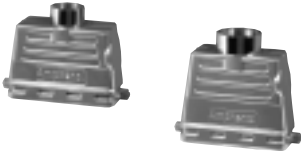
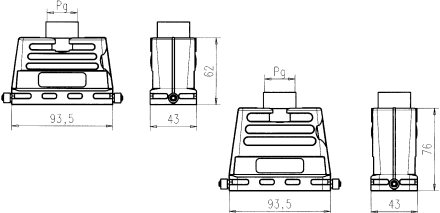

Bei Sockelgehäusen Abgang rechts dargestellt / *housings are shown with right outlet*

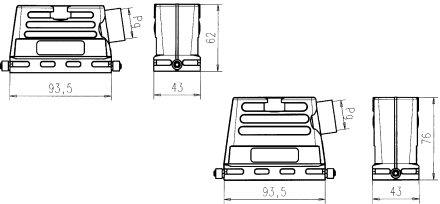
C 146 E 16 pol.
C 146 M 5 Module
C 146 D 40 pol.
C 146 DD 72 pol.
C 146 HSE 6 pol.
C 146 HvE 6 pol.
C 146 EE 32 pol.
Gehäuse / Housings

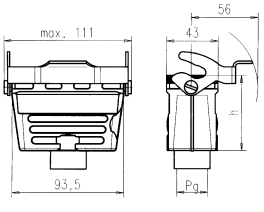
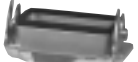
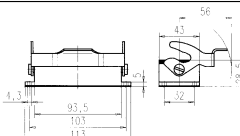
**Gehäuse für Längsbügelverriegelung nach
 DIN EN 175 301 - 801 (DIN 43 652)**

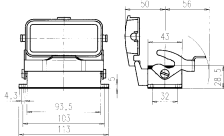
- leichtes Bedienen auch bei seitlichem Kabelabgang
- Schutzkappe am Gehäuseunterteil verriegelbar
- fliegende Verbindung möglich

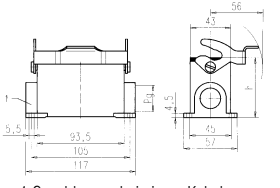
**PG-Gewinde
 PG-thread**

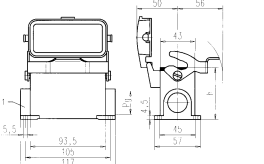
Bezeichnung - Abbildung Description - Figure	Maßzeichnung Drawing	PG	Bestell Nr. / Part No.		
			Niedrige Bauform / Low profile	Hohe Bauform / High profile	
Gehäuseoberteile / Hoods					
Tüllengehäuse, Abgang oben Hood, top entry 		21	C146 10G016 606 1		
		29	C146 10G016 607 1		
		21		C146 10G016 606 8	
		29		C146 10G016 607 8	
Tüllengehäuse, Abgang Seite Hood, side entry 		21	C146 10G016 506 1		
		29	C146 10G016 507 1		
		21		C146 10G016 506 8	
		29		C146 10G016 507 8	
Gehäuseunterteile / Housings					
Kupplungsgehäuse Hood, coupling application 		h			
		62	21	C146 10G016 804 1	
		62	29	C146 10G016 805 1	
		76	21		C146 10G016 804 8
76	29		C146 10G016 805 8		
Anbaugehäuse ¹⁾ Housing, bulkhead mounting ¹⁾ 		-	C146 10F016 001 1		
Anbaugehäuse mit Deckel ¹⁾ Housing with spring cover ¹⁾ 		-	C146 10F016 003 1		
Sockelgehäuse Housing 		h	1 Kabelabgang / Single side entry		
		64/77	21	C146 10F016 802 1	C146 10F040 803 2
		64/77	21	C146 10F016 502 1 ^(*)	C146 10F040 503 2 ^(*)
		77	29		C146 10F040 802 2
		77	29		C146 10F040 502 2 ^(*)
		64	21	2 Kabelabgänge / Double side entry	
77	29	C146 10F016 602 1	C146 10F040 603 2		
			C146 10F040 602 2		
Sockelgehäuse mit Deckel Housing with spring cover 		h	1 Kabelabgang / Single side entry		
		64/77	21	C146 10F016 806 1	C146 10F040 807 2
		64/77	21	C146 10F016 506 1 ^(*)	C146 10F040 507 2 ^(*)
		77	29		C146 10F040 806 2
		77	29		C146 10F040 506 2 ^(*)
		64/77	21	2 Kabelabgänge / Double side entry	
77	29	C146 10F016 606 1	C146 10F040 607 2		
			C146 10F040 606 2		

¹⁾incl. Flachdichtung / incl. gasket

^(*) links / left

**housings for 1 locking-lever-system according to
 DIN EN 175 301 - 801 (DIN 43 652)**

- also easy to use for side entry
- cover for housings lockable
- cable to cable possible

**Metrisches Gewinde
Metric thread**

Maßzeichnung <i>Drawing</i>	M	Bestell Nr. / <i>Part No.</i>		Bestell Nr. / <i>Part No.</i>		
		Niedrige Bauform/ <i>Low profile</i>	Hohe Bauform/ <i>High profile</i>	Niedrige Bauform/ <i>Low profile</i>	Hohe Bauform/ <i>High profile</i>	
		mit Stutzen / <i>with stud</i>		ohne Stutzen / <i>without stud</i>		
	25	C146 10R016 656 1		C146 21R016 656 1		
	32	C146 10R016 606 1		C146 21R016 606 1		
	25		C146 10R016 656 8		C146 21R016 656 8	
	32		C146 10R016 606 8		C146 21R016 606 8	
	40		C146 10R016 607 8		C146 21R016 607 8	
	25	C146 10R016 556 1		C146 21R016 556 1		
	32	C146 10R016 506 1		C146 21R016 506 1		
	25		C146 10R016 556 8		C146 21R016 556 8	
	32		C146 10R016 506 8		C146 21R016 506 8	
	32		C146 10R016 507 8		C146 21R016 507 8	
	40					
	40					
	h					
	62	25	C146 10R016 854 1		C146 21R016 854 1	
	62	32	C146 10R016 804 1		C146 21R016 804 1	
	76	25		C146 10R016 854 8		C146 21R016 854 8
	76	32		C146 10R016 804 8		C146 21R016 804 8
76	40		C146 10R016 805 8		C146 21R016 805 8	
		–	C146 10F016 001 1			
			–	C146 10F016 003 1		
<p>1 Geschlossen bei einem Kabelausgang 1 closed if single entry</p>		h		1 Kabelabgang / <i>Single side entry</i>		2 Kabelabgänge / <i>Double side entry</i>
	64/77	25	C146 10N016 802 1	C146 10N016 803 2	C146 10N016 602 1	C146 10N016 603 2
	64/77	25	C146 10N016 502 1 (*)	C146 10N016 503 2 (*)	C146 10N016 702 1 (*)	C146 10N016 703 2 (*)
	77	32		C146 10N016 802 2		C146 10N016 602 2
	77	32		C146 10N016 502 2 (*)		C146 10N016 702 2 (*)
<p>1 Geschlossen bei einem Kabelausgang 1 closed if single entry</p>	h		1 Kabelabgang / <i>Single side entry</i>		2 Kabelabgänge / <i>Double side entry</i>	
	64/77	25	C146 10N016 806 1	C146 10N016 807 2	C146 10N016 606 1	C146 10N016 607 2
	64/77	25	C146 10N016 506 1 (*)	C146 10N016 507 2 (*)	C146 10N016 708 1 (*)	C146 10N016 709 2 (*)
	77	32		C146 10N016 806 2		C146 10N016 606 2
	77	32		C146 10N016 506 2 (*)		C146 10N016 708 2 (*)

(*) links / left

(*) rechts und unten / right and bottom







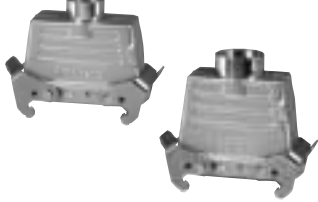
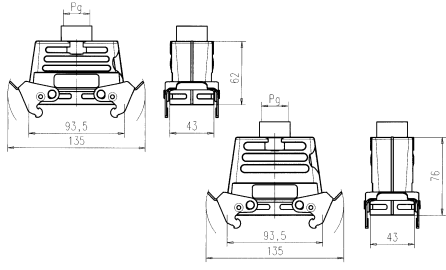

Bei Sockelgehäusen Abgang rechts dargestellt / housings are shown with right outlet

C 146 E 16 pol.
C 146 M 5 Module
C 146 D 40 pol.
C 146 DD 72 pol.
C 146 HSE 6 pol.
C 146 HvE 6 pol.
C 146 EE 32 pol.
 Gehäuse / Housings

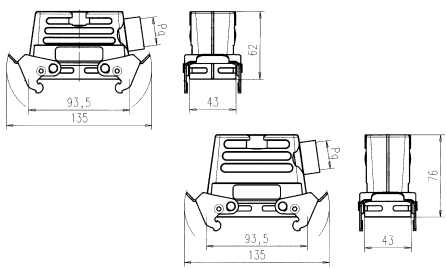
**Tüllengehäuse mit Querbügel nach
 DIN EN 175 301 - 801 (DIN 43 652)**

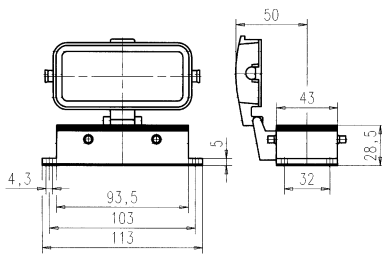
- sichere 4-Punkt Verriegelung
- Gehäuseunterteil mit Schutzdeckel
- keine Bügel am Gehäuseunterteil

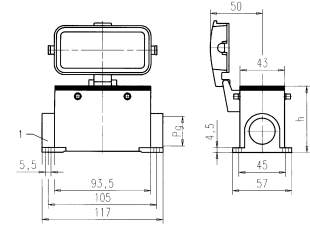
**PG-Gewinde
 PG-thread**

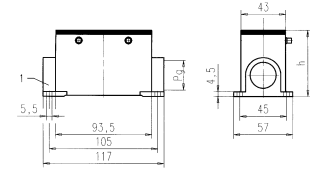
Bezeichnung - Abbildung Description - Figure	Maßzeichnung Drawing	PG	Bestell Nr. / Part No. Niedrige Bauform / Low profile Hohe Bauform / High profile		
Gehäuseoberteile / Hoods					
Tüllengehäuse, Abgang oben <i>Hood, top entry</i> 		21	C146 10G016 602 1		
		29	C146 10G016 603 1		
		21		C146 10G016 602 8	
		29		C146 10G016 603 8	
Tüllengehäuse, Abgang Seite <i>Hood, side entry</i> 		21	C146 10G016 502 1		
		29	C146 10G016 503 1		
		21		C146 10G016 502 8	
		29		C146 10G016 503 8	
Gehäuseunterteile / Housings					
Anbaugehäuse mit Deckel ¹⁾ <i>Housing, with spring cover ¹⁾</i> 		-	C146 10F016 002 1		
Sockelgehäuse, mit Deckel <i>Housing, with spring cover</i> 	 <p>1 Geschlossen bei einem Kabelausgang 1 closed if single entry</p>	h	1 Kabelabgang / Single side entry		
		64/77	21	C146 10F016 804 1	C146 10F040 805 2
		64/77	21	C146 10F016 504 1 ^(*)	C146 10F040 505 2 ^(*)
		77	29		C146 10F040 804 2
		77	29	C146 10F040 504 2 ^(*)	
		h	2 Kabelabgänge / Double side entry		
		64/77	21	C146 10F016 604 1	C146 10F040 605 2
		77	29	C146 10F040 604 2	
Sockelgehäuse <i>Housing</i> 	 <p>1 Geschlossen bei einem Kabelausgang 1 closed if single entry</p>	h	1 Kabelabgang / Single side entry		
		77	21		C146 10F016 509 2
		77	29		C146 10F016 508 2
		h	2 Kabelabgänge / Double side entry		
		77	21	C146 10F016 609 2	
		77	29	C146 10F016 608 2	

¹⁾incl. Flachdichtung / incl. gasket

Bei Sockelgehäusen Abgang rechts dargestellt / housings are shown with right out

hoods with 2 locking-levers according to
DIN EN 175 301 - 801 (DIN 43 652)

- secured 4 point locking
- housing with cover
- no locking levers at the housings

Metrisches Gewinde
Metric thread

Maßzeichnung Drawing	M	Bestell Nr. / Part No.		Bestell Nr. / Part No.		
		Niedrige Bauform/ Low profile	Hohe Bauform/ High profile	Niedrige Bauform/ Low profile	Hohe Bauform/ High profile	
		mit Stutzen / with stud		ohne Stutzen / without stud		
	25	C146 10R016 652 1		C146 21R016 652 1		
	32	C146 10R016 602 1		C146 21R016 602 1		
	25		C146 10R016 652 8		C146 21R016 652 8	
	32		C146 10R016 602 8		C146 21R016 602 8	
	25	C146 10R016 552 1		C146 21R016 552 1		
	32	C146 10R016 502 1		C146 21R016 502 1		
	25		C146 10R016 552 8		C146 21R016 552 8	
	32		C146 10R016 502 8		C146 21R016 502 8	
	40		C146 10R016 603 8		C146 21R016 603 8	
	-	C146 10F016 002 1				
<p>1 Geschlossen bei einem Kabelausgang 1 closed if single entry</p>	h	1 Kabelabgang / Single side entry		2 Kabelabgänge / Double side entry		
	64/77	25	C146 10N016 804 1	C146 10N016 805 2	C146 10N016 604 1	C146 10N016 605 2
	64/77	25	C146 10N016 504 1 ^(*)	C146 10N016 505 2 ^(*)	C146 10N016 808 1 ^(**u)	C146 10N016 809 2 ^(**u)
	77	32		C146 10N016 804 2		C146 10N016 604 2
<p>1 Geschlossen bei einem Kabelausgang 1 closed if single entry</p>	h	1 Kabelabgang / Single side entry		2 Kabelabgänge / Double side entry		
	64/77	25	C146 10N016 508 1	C146 10N016 509 2	C146 10N016 608 1	C146 10N016 609 2
	77	32		C146 10N016 508 2		C146 10N016 608 2

^(*) links / left





^(**u) rechts und unten / right and bottom

C 146 E 16 pol.
C 146 M 5 Module
C 146 D 40 pol.
C 146 DD 72 pol.
C 146 HSE 6 pol.
C 146 HvE 6 pol.
C 146 EE 32 pol.
 Gehäuse / Housings

**Sondergehäuse für Querbügelverriegelung, nach
 DIN EN 175 301 - 801 (DIN 43 652)**

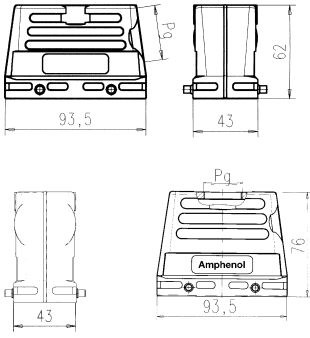
*special housings for 2 locking-lever system,
 according to DIN EN 175 301 - 801 (DIN 43 652)*

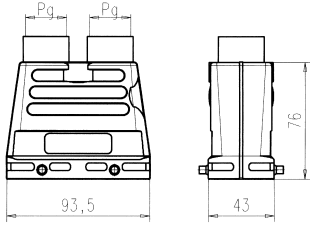
**PG-Gewinde
 PG-thread**

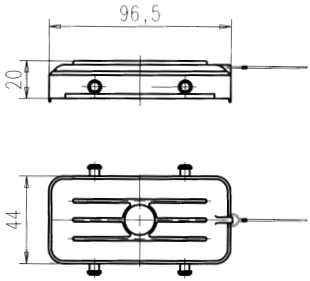
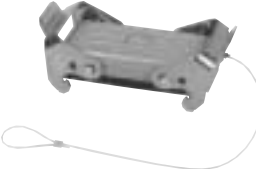
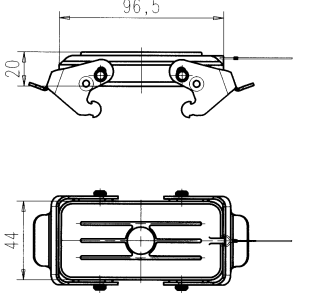
Bezeichnung - Abbildung Description - Figure	Maßzeichnung Drawing	PG	Kabelabgang cable outlet	Bestell Nr. / Part No.	
				Niedrige Bauform / Low profile	Hohe Bauform / High profile
Gehäuseoberteile / Hoods					
Tüllengehäuse ohne Stutzen <i>Hood without stud</i> 		21	Oben / top Seite / side	C146 21G016 600 1 C146 21G016 500 1	
		29	Oben / top Seite / side		C146 21G016 601 8 C146 21G016 501 8
Tüllengehäuse, 2 x Abgang Oben <i>Hood, 2 top entry</i> 		21			C146 10G016 902 8
Schutzkappen / Protective cover					
Schutzkappe für Gehäuseunterteile <i>Cover for housings</i> 		-		C146 10Z016 100 1	
Schutzkappe für Gehäuseoberteile <i>Cover for hoods</i> 		-		C146 10Z016 200 1	



Verschraubung für Tüllen- und Sockelgehäuse siehe Seite 180-183 / gland bushings for hoods and housing see page 180-183
 Zubehör siehe Seite 184-186 / accessories see page 184-186

C 146 E 16 pol.
C 146 M 5 Module
C 146 D 40 pol.
C 146 DD 72 pol.
C 146 HSE 6 pol.
C 146 HvE 6 pol.
C 146 EE 32 pol.
Gehäuse / Housings

**Sondergehäuse für Querbügelverriegelung, nach
 DIN EN 175 301 - 801 (DIN 43 652)**

*special housings for 2 locking-lever system,
 according to DIN EN 175 301 - 801 (DIN 43 652)*

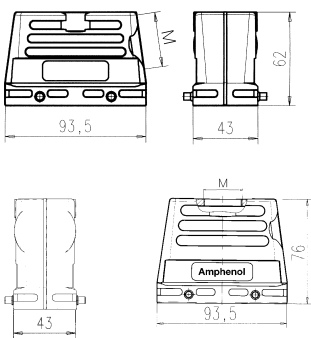
**Metrisches Gewinde
 Metric thread**

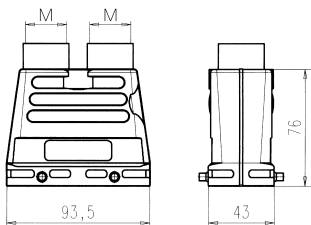
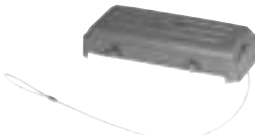
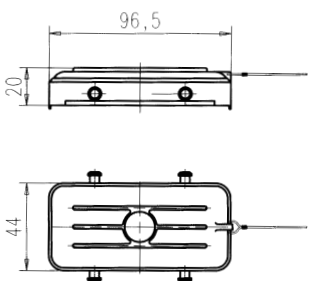
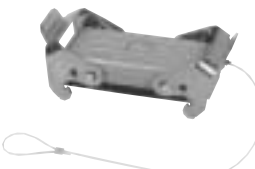
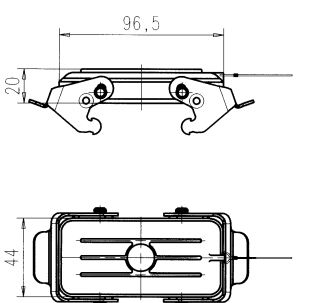
Bezeichnung - Abbildung <i>Description - Figure</i>	Maßzeichnung <i>Drawing</i>	M	Kabelabgang <i>cabl e outlet</i>	Bestell Nr. / <i>Part No.</i>	
				Niedrige Bauform / <i>Low profile</i>	Hohe Bauform / <i>High profile</i>
Gehäuseoberteile / Hoods					
Tüllengehäuse ohne Stutzen <i>Hood without stud</i> 		25	Oben / <i>top</i>	C146 21R016 650 1	C146 21R016 650 8
			Seite / <i>side</i>	C146 21R016 550 1	C146 21R016 550 8
		32	Oben / <i>top</i>	C146 21R016 600 1	C146 21R016 600 8
			Seite / <i>side</i>	C146 21R016 500 1	C146 21R016 500 8
Tüllengehäuse, 2 x Abgang Oben <i>Hood, 2 top entry</i> 		25			C146 10R016 910 8
		32			
Schutzkappen / Protective cover					
Schutzkappe für Gehäuseunterteile <i>Cover for housings</i> 		-		C146 10Z016 100 1	
Schutzkappe für Gehäuseoberteile <i>Cover for hoods</i> 		-		C146 10Z016 200 1	

Verschraubung für Tüllen- und Sockelgehäuse siehe Seite 180-183 / *gland bushings for hoods and housing see page 180-183*
 Zubehör siehe Seite 184-186 / *accessories see page 184-186*







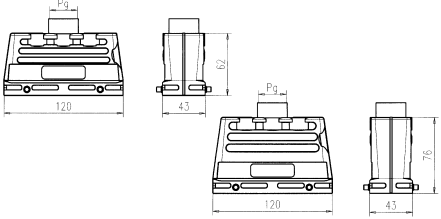

C 146 E 24 pol.
 C 146 M 7 Module
 C 146 D 64 pol.
 C 146 DD 108 pol.
 C 146 HvE 10 pol.
 C 146 EE 46 pol.

Gehäuse / Housings

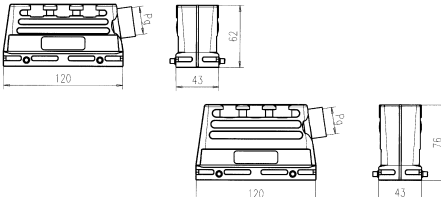
Gehäuse für Querbügelverriegelung nach
 DIN EN 175 301 - 801 (DIN 43 652)

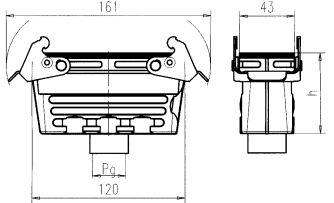
- sichere 4-Punkt Verriegelung
- bevorzugt bei seitlicher Anreihung
- fliegende Verbindung möglich

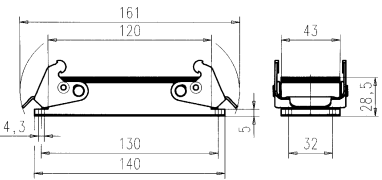
PG-Gewinde
 PG-thread

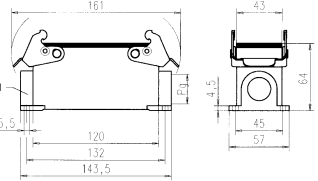
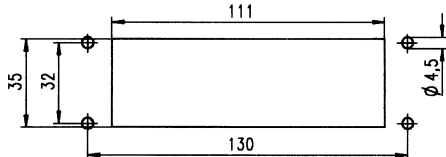
Bezeichnung - Abbildung Description - Figure	Maßzeichnung Drawing	PG	Bestell Nr. / Part No.		
			Niedrige Bauform / Low profile	Hohe Bauform / High profile	
Gehäuseoberteile / Hoods					
Tüllengehäuse, Abgang oben Hood, top entry 		21	C146 10G024 600 1		
		29	C146 10G024 601 1		
		21		C146 10G024 600 8	
		29		C146 10G024 601 8	
Tüllengehäuse, Abgang Seite Hood, side entry 		21	C146 10G024 500 1		
		29	C146 10G024 501 1		
		21		C146 10G024 500 8	
		29		C146 10G024 501 8	
Gehäuseunterteile / Housings					
Kupplungsgehäuse Hood, coupling application 		h 62	21	C146 10G024 802 1	
		62	29	C146 10G024 803 1	
		76	21		C146 10G024 802 8
		76	29		C146 10G024 803 8
Anbaugehäuse ¹⁾ Housing, bulkhead mounting ¹⁾ 				C146 10F024 000 1	
Sockelgehäuse Housing 					1 Kabelabgang / Single side entry
		h 64/80	21	C146 10F024 500 1	C146 10F064 501 2
		80	29		C146 10F064 500 2
					2 Kabelabgänge / Double side entry
		h 64/80	21	C146 10F024 600 1	C146 10F064 601 2
		80	29		C146 10F064 600 2
Montageausschnitt für Anbaugehäuse / Panel cut out for housing bulkhead mounting					
					

¹⁾ incl. Flachdichtung / incl. gasket Zubehör siehe Seite 184-186 / accessories see page 184-186
 Verschraubung für Tüllen- und Sockelgehäuse siehe Seite 180-183 / gland bushings for hoods and housing see page 180-183

**housings for 2 locking-lever-system according to
 DIN EN 175 301 - 801 (DIN 43 652)**

- **secured 4 point locking**
- **preferred for side by side mounting**
- **cable to cable possible**

**Metrisches Gewinde
Metric thread**

Maßzeichnung <i>Drawing</i>	M	Bestell Nr. / <i>Part No.</i>		Bestell Nr. / <i>Part No.</i>		
		Niedrige Bauform/ <i>Low profile</i>	Hohe Bauform/ <i>High profile</i>	Niedrige Bauform/ <i>Low profile</i>	Hohe Bauform/ <i>High profile</i>	
		mit Stützen / <i>with stud</i>		ohne Stützen / <i>without stud</i>		
	25	C146 10R024 650 1		C146 21R024 650 1		
	32	C146 10R024 600 1		C146 21R024 600 1		
	25		C146 10R024 650 8		C146 21R024 650 8	
	32		C146 10R024 600 8		C146 21R024 600 8	
	40		C146 10R024 601 8		C146 21R024 601 8	
	25	C146 10R024 550 1		C146 21R024 550 1		
	32	C146 10R024 500 1		C146 21R024 500 1		
	25		C146 10R024 550 8		C146 21R024 550 8	
	32		C146 10R024 500 8		C146 21R024 500 8	
	40		C146 10R024 501 8		C146 21R024 501 8	
	h					
	62	25	C146 10R024 852 1		C146 21R024 852 1	
	62	32	C146 10R024 802 1		C146 21R024 802 1	
	76	25		C146 10R024 852 8		C146 21R024 852 8
	76	32		C146 10R024 802 8		C146 21R024 802 8
	76	40		C146 10R024 803 8		C146 21R024 803 8
	-	C146 10F024 000 1				
	h					
<p>1 Geschlossen bei einem Kabelausgang 1 closed if single entry</p>	25	1 Kabelabgang / <i>Single side entry</i>		2 Kabelabgänge / <i>Double side entry</i>		
	64/80	C146 10N024 500 1	C146 10N024 501 2	C146 10N024 600 1	C146 10N024 601 2	
	64/80			C146 10N024 700 1 ^(r+u)	C146 10N024 701 2 ^(r+u)	
	80		C146 10N024 500 2		C146 10N024 600 2	
80				C146 10N024 700 2 ^(r+u)		

^(r+u) rechts und unten / *right and bottom*

Bei Sockelgehäusen Abgang rechts dargestellt / *housings are shown with right out*











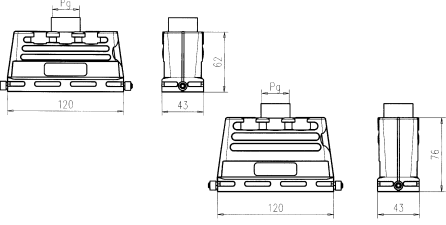

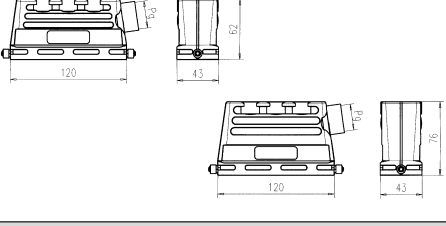
C 146 E 24 pol.
C 146 M 7 Module
C 146 D 64 pol.
C 146 DD 108 pol.
C 146 HvE 10 pol.
C 146 EE 46 pol.

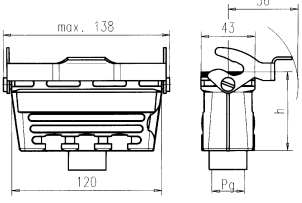
Gehäuse / Housings

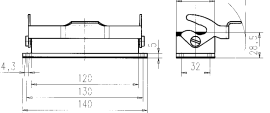
Gehäuse für Längsbügelverriegelung nach
 DIN EN 175 301 - 801 (DIN 43 652)

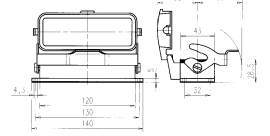
- leichtes Bedienen auch bei seitlichem Kabelabgang
- Schutzkappe am Gehäuseunterteil verriegelbar
- fliegende Verbindung möglich

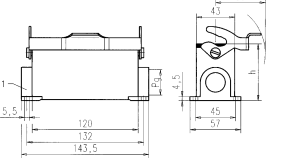
PG-Gewinde
PG-thread

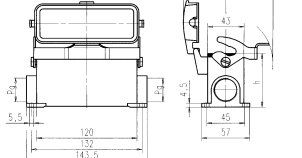
Bezeichnung - Abbildung Description - Figure	Maßzeichnung Drawing	PG	Bestell Nr. / Part No.		
			Niedrige Bauform / Low profile	Hohe Bauform / High profile	
Gehäuseoberteile / Hoods					
Tüllengehäuse, Abgang oben <i>Hood, top entry</i> 		21	C146 10G024 606 1		
		29	C146 10G024 607 1		
		21		C146 10G024 606 8	
		29		C146 10G024 607 8	
Tüllengehäuse, Abgang Seite <i>Hood, side entry</i> 		21	C146 10G024 506 1		
		29	C146 10G024 507 1		
		21		C146 10G024 506 8	
		29		C146 10G024 507 8	
Gehäuseunterteile / Housings					
Kupplungsgehäuse <i>Hood, coupling application</i> 		h			
		62	21	C146 10G024 804 1	
		62	29	C146 10G024 805 1	
		76	21		C146 10G024 804 8
76	29		C146 10G024 805 8		
Anbaugehäuse ¹⁾ <i>Housing, bulkhead mounting ¹⁾</i> 		–	C146 10F024 001 1		
Anbaugehäuse mit Deckel ¹⁾ <i>Housing with spring cover ¹⁾</i> 		–	C146 10F024 003 1		
Sockelgehäuse <i>Housing</i> 		h	1 Kabelabgang / Single side entry		
		64/80	21	C146 10F024 802 1	C146 10F064 803 2
		64/80	21	C146 10F024 502 1 ^(*)	C146 10F064 503 2 ^(*)
		80	29		C146 10F064 802 2
		80	29		C146 10F064 502 2 ^(*)
		80	29	2 Kabelabgänge / Double side entry	
64/80	21	C146 10F024 602 1	C146 10F064 603 2		
80	29		C146 10F064 602 2		
Sockelgehäuse mit Deckel <i>Housing with spring cover</i> 		h	1 Kabelabgang / Single side entry		
		64/80	21	C146 10F024 806 1	C146 10F064 807 2
		64/80	21	C146 10F024 506 1 ^(*)	C146 10F064 507 2 ^(*)
		80	29		C146 10F064 806 2
		80	29		C146 10F064 506 2 ^(*)
		80	29	2 Kabelabgänge / Double side entry	
64/80	21	C146 10F024 606 1	C146 10F064 607 2		
80	29		C146 10F064 606 2		

¹⁾incl. Flachdichtung / incl. flat gasket

Bei Sockelgehäusen Abgang rechts dargestellt / housings are shown with right out

housings for 1 locking-lever-system according to
 DIN EN 175 301 - 801 (DIN 43 652)

- also easy to use for side entry
- cover for housings lockable
- cable to cable possible

Metrisches Gewinde
 Metric thread

Maßzeichnung Drawing	M	Bestell Nr. / Part No.		Bestell Nr. / Part No.		
		Niedrige Bauform/ Low profile	Hohe Bauform/ High profile	Niedrige Bauform/ Low profile	Hohe Bauform/ High profile	
		mit Stutzen / with stud		ohne Stutzen / without stud		
	25	C146 10R024 656 1		C146 21R024 656 1		
	32	C146 10R024 606 1		C146 21R024 606 1		
	25		C146 10R024 656 8		C146 21R024 656 8	
	32		C146 10R024 606 8		C146 21R024 606 8	
	40		C146 10R024 607 8		C146 21R024 607 8	
	25	C146 10R024 556 1		C146 21R024 556 1		
	32	C146 10R024 506 1		C146 21R024 506 1		
	25		C146 10R024 556 8		C146 21R024 556 8	
	32		C146 10R024 506 8		C146 21R024 506 8	
	32		C146 10R024 507 8		C146 21R024 507 8	
	40					
	40					
	h					
	62	25	C146 10R024 854 1		C146 21R024 854 1	
	62	32	C146 10R024 804 1		C146 21R024 804 1	
	76	25		C146 10R024 854 8		C146 21R024 854 8
	76	32		C146 10R024 804 8		C146 21R024 804 8
	76	40		C146 10R024 805 8		C146 21R024 805 8
		–	C146 10F024 001 1			
		–	C146 10F024 003 1			
	<p>1 Geschlossen bei einem Kabelausgang 1 closed if single entry</p>	h		1 Kabelabgang / Single side entry		2 Kabelabgänge / Double side entry
64/80		25	C146 10N024 802 1	C146 10N024 803 2	C146 10N024 602 1	C146 10N024 603 2
64/80		25	C146 10N024 502 1 ^(*)	C146 10N024 503 2 ^(*)	C146 10N024 702 1 ^(**)	C146 10N024 703 2 ^(**)
80		32		C146 10N024 802 2		C146 10N024 602 2
80		32		C146 10N024 502 2 ^(*)		C146 10N024 702 2 ^(**)
<p>1 Geschlossen bei einem Kabelausgang 1 closed if single entry</p>	h		1 Kabelabgang / Single side entry		2 Kabelabgänge / Double side entry	
	64/80	25	C146 10N024 806 1	C146 10N024 807 2	C146 10N024 606 1	C146 10N024 607 2
	64/80	25	C146 10N024 506 1 ^(*)	C146 10N024 507 2 ^(*)	C146 10N024 708 1 ^(**)	C146 10N024 709 2 ^(**)
	80	32		C146 10N024 806 2		C146 10N024 606 2
	80	32		C146 10N024 506 2 ^(*)		C146 10N024 708 2 ^(**)

(*) links / left

(**) rechts und unten / right and bottom







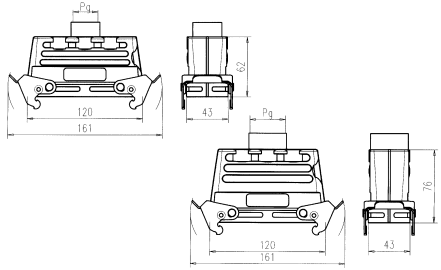

C 146 E 24 pol.
C 146 M 7 Module
C 146 D 64 pol.
C 146 DD 108 pol.
C 146 HvE 10 pol.
C 146 EE 46 pol.

Gehäuse / Housings

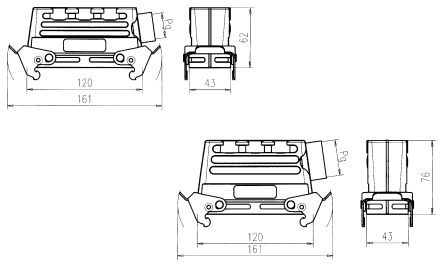
**Tüllengehäuse mit Querbügel nach
 DIN EN 175 301 - 801 (DIN 43 652)**

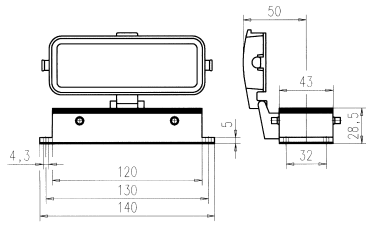
- sichere 4-Punkt Verriegelung
- Gehäuseunterteil mit Schutzdeckel
- keine Bügel am Gehäuseunterteil

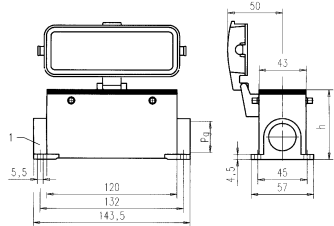
**PG-Gewinde
 PG-thread**

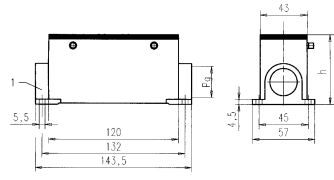
Bezeichnung - Abbildung Description - Figure	Maßzeichnung Drawing	PG	Bestell Nr. / Part No. Niedrige Bauform / Low profile Hohe Bauform / High profile		
Gehäuseoberteile / Hoods					
Tüllengehäuse, Abgang oben <i>Hood, top entry</i> 		21	C146 10G024 602 1	C146 10G024 602 8 C146 10G024 603 8	
		29	C146 10G024 603 1		
		21			
		29			
Tüllengehäuse, Abgang Seite <i>Hood, side entry</i> 		21	C146 10G024 502 1	C146 10G024 502 8 C146 10G024 503 8	
		29	C146 10G024 503 1		
		21			
		29			
Gehäuseunterteile / Housings					
Anbaugehäuse mit Deckel ¹⁾ <i>Housing, with spring cover ¹⁾</i> 		-	C146 10F024 002 1		
Sockelgehäuse, mit Deckel <i>Housing, with spring cover</i> 		1 Kabelabgang / Single side entry			
		h 64/80	21	C146 10F024 804 1	C146 10F064 805 2
		64/80	21	C146 10F024 504 1 ^(*)	C146 10F064 505 2 ^(*)
		80	29		C146 10F064 804 2
			2 Kabelabgänge / Double side entry		
64/80	21	C146 10F024 604 1	C146 10F064 605 2		
80	29		C146 10F064 604 2		
Sockelgehäuse <i>Housing</i> 		1 Kabelabgang / Single side entry			
		h 80	21		C146 10F024 509 2
		80	29		C146 10F024 508 2
					2 Kabelabgänge / Double side entry
80	21		C146 10F024 609 2		
80	29		C146 10F024 608 2		

¹⁾incl. Flachdichtung / incl. gasket

Bei Sockelgehäusen Abgang rechts dargestellt / housings are shown with right out

hoods with 2 locking-levers according to
DIN EN 175 301 - 801 (DIN 43 652)

- secured 4 point locking
- housing with cover
- no locking levers at the housings

Metrisches Gewinde
Metric thread

Maßzeichnung Drawing	M	Bestell Nr. / Part No.		Bestell Nr. / Part No.		
		Niedrige Bauform/ Low profile	Hohe Bauform/ High profile	Niedrige Bauform/ Low profile	Hohe Bauform/ High profile	
		mit Stützen / with stud		ohne Stützen / without stud		
	25	C146 10R024 652 1		C146 21R024 652 1		
	32	C146 10R024 602 1		C146 21R024 602 1		
	25		C146 10R024 652 8		C146 21R024 652 8	
	32		C146 10R024 602 8		C146 21R024 602 8	
	40		C146 10R024 603 8		C146 21R024 603 8	
	25	C146 10R024 552 1		C146 21R024 552 1		
	32	C146 10R024 502 1		C146 21R024 502 1		
	25		C146 10R024 552 8		C146 21R024 552 8	
	32		C146 10R024 502 8		C146 21R024 502 8	
	40		C146 10R024 503 8		C146 21R024 503 8	
	C146 10F024 002 1					
	<p>1 Geschlossen bei einem Kabelausgang 1 closed if single entry</p>	h	1 Kabelabgang / Single side entry		2 Kabelabgänge / Double side entry	
64/80		25	C146 10N024 804 1	C146 10N024 805 2	C146 10N024 604 1	C146 10N024 605 2
64/80		25	C146 10N024 504 1 (*)	C146 10N024 505 2 (*)	C146 10N024 808 1 (*)	C146 10N024 809 2 (*)
80		32		C146 10N024 804 2		C146 10N024 604 2
80		32		C146 10N024 504 2 (*)		C146 10N024 808 2 (*)
<p>1 Geschlossen bei einem Kabelausgang 1 closed if single entry</p>	h	1 Kabelabgang / Single side entry		2 Kabelabgänge / Double side entry		
	64/80	25	C146 10N024 508 1	C146 10N024 509 2	C146 10N024 608 1	C146 10N024 609 2
	80	32		C146 10N024 508 2		C146 10N024 608 2

(*) links / left





(*) rechts und unten / right and bottom

C 146 E 24 pol.
C 146 M 7 Module
C 146 D 64 pol.
C 146 DD 108 pol.
C 146 HvE 10 pol.
C 146 EE 46 pol.
 Gehäuse, Schutzkappen
Housings, covers

**Sondergehäuse für Querbügelverriegelung, nach
 DIN EN 175 301 - 801 (DIN 43 652)**

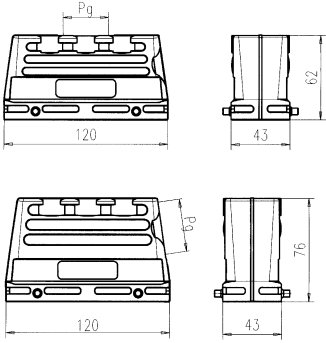
*special housings for 2 locking-lever systems,
 according to DIN EN 175 301 - 801 (DIN 43 652)*

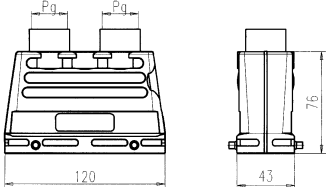
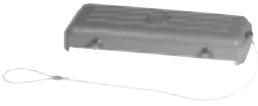
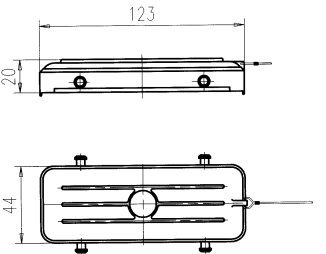
PG-Gewinde
PG-thread

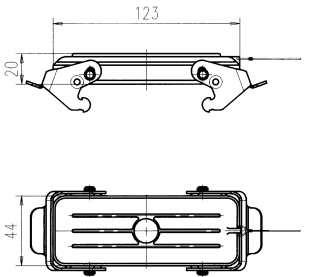
Bezeichnung - Abbildung <i>Description - Figure</i>	Maßzeichnung <i>Drawing</i>	PG	Kabelabgang <i>cabl e outlet</i>	Bestell Nr. / <i>Part No.</i>	
				Niedrige Bauform / <i>Low profile</i>	Hohe Bauform / <i>High profile</i>
Gehäuseoberteile / Hoods					
Tüllengehäuse ohne Stutzen <i>Hood without stud</i> 		21	Oben / <i>top</i>	C146 21G024 600 1	
			Seite / <i>side</i>	C146 21G024 500 1	
Tüllengehäuse, 2 x Abgang Oben <i>Hood, 2 top entry</i> 		21			C146 10G024 903 8
			29	Oben / <i>top</i>	
			Seite / <i>side</i>		
Schutzkappen / covers					
Schutzkappe für Gehäuseunterteile <i>Cover for housings</i> 		-		C146 10Z024 100 1	
Schutzkappe für Gehäuseoberteile <i>Cover for hoods</i> 		-		C146 10Z024 200 1	



Verschraubung für Tüllen- und Sockelgehäuse siehe Seite 180-183 / *gland bushings for hoods and housing see page 180-183*
 Zubehör siehe Seite 184-186 / *accessories see page 184-186*

C 146 E 24 pol.
C 146 M 7 Module
C 146 D 64 pol.
C 146 DD 108 pol.
C 146 HvE 10 pol.
C 146 EE 46 pol.
 Gehäuse, Schutzkappen
Housings, covers

**Sondergehäuse für Querbügelverriegelung, nach
 DIN EN 175 301 - 801 (DIN 43 652)**

*special housings for 2 locking-lever systems,
 according to DIN EN 175 301 - 801 (DIN 43 652)*

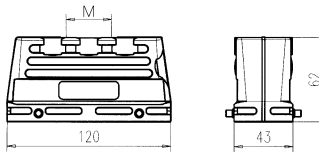
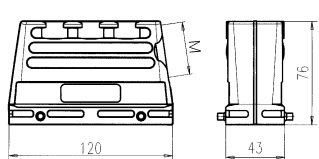
Metrisches Gewinde
Metric thread

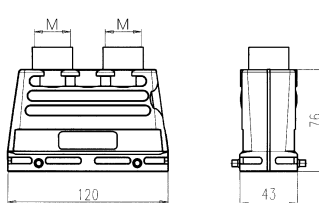
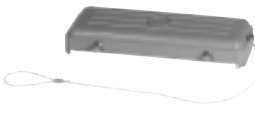
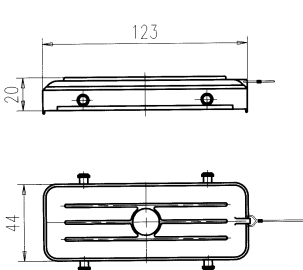
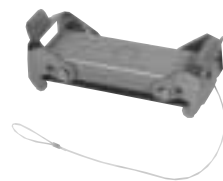
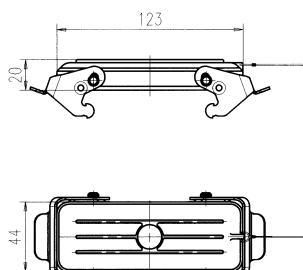
Bezeichnung - Abbildung <i>Description - Figure</i>	Maßzeichnung <i>Drawing</i>	M	Kabelabgang <i>cabl e outlet</i>	Bestell Nr. / <i>Part No.</i>	
Gehäuseoberteile / Hoods					
Niedrige Bauform / <i>Low profile</i> Hohe Bauform / <i>High profile</i>					
Tüllengehäuse ohne Stutzen <i>Hood without stud</i> 		25	Oben / <i>top</i>	C146 21R024 650 1	C146 21R024 650 8
			Seite / <i>side</i>	C146 21R024 550 1	C146 21R024 550 8
		32	Oben / <i>top</i>	C146 21R024 600 1	C146 21R024 600 8
			Seite / <i>side</i>	C146 21R024 500 1	C146 21R024 500 8
Tüllengehäuse, 2 x Abgang Oben <i>Hood, 2 top entry</i> 		32/40			C146 10R024 909 8
		32			C146 10R024 903 8
		40			C146 10R024 908 8
Schutzkappen / covers					
Schutzkappe für Gehäuseunterteile <i>Cover for housings</i> 		-		C146 10Z024 100 1	
Schutzkappe für Gehäuseoberteile <i>Cover for hoods</i> 		-		C146 10Z024 200 1	

Verschraubung für Tüllen- und Sockelgehäuse siehe Seite 180-183 / *gland bushings for hoods and housing see page 180-183*
 Zubehör siehe Seite 184-186 / *accessories see page 184-186*



C 146 E 48 pol.
 C 146 M 14 Module
 C 146 D 128 pol.
 C 146 DD 216 pol.
 C 146 HVE 32 pol.

Gehäuse für Längsbügelverriegelung

housings for 1 locking-lever-systems

Gehäuse
 Housings

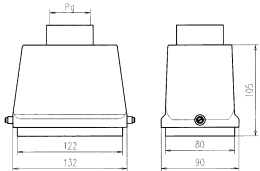
PG-Gewinde
 PG-thread

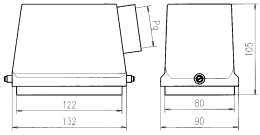
Bezeichnung - Abbildung Description - Figure	Maßzeichnung Drawing	PG	Bestell Nr. Part No.
Gehäuseoberteile / Hoods			
Tüllengehäuse, Abgang oben <i>Hood, top entry</i> 		29	C146 10G048 606 1
Tüllengehäuse, Abgang Seite <i>Hood, side entry</i> 		29	C146 10G048 506 1
		36	C146 10G048 607 1
		42	C146 10G048 608 1
		36	C146 10G048 507 1
		42	C146 10G048 508 1

Verschraubung für Tüllen- und Sockelgehäuse siehe Seite 180-183 / gland bushings for hoods and housing see page 180-183
 Zubehör siehe Seite 184-186 / accessories see page 184-186



C 146 E 48 pol.
 C 146 M 14 Module
 C 146 D 128 pol.
 C 146 DD 216 pol.
 C 146 HVE 32 pol.

Gehäuse für Längsbügelverriegelung

housings for 1 locking-lever-systems

Gehäuse
 Housings

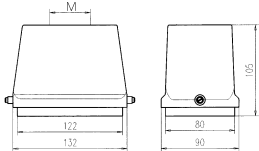
Metrisches Gewinde
 Metric thread

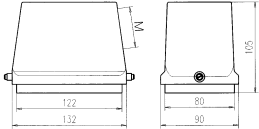
Bezeichnung - Abbildung Description - Figure	Maßzeichnung Drawing	M	Bestell Nr. Part No.
Gehäuseoberteile / Hoods		ohne Stutzen / without stud	
Tüllengehäuse, Abgang oben <i>Hood, top entry</i> 		32 40 50	C146 21R048 606 1 C146 21R048 607 1 C146 21R048 608 1
Tüllengehäuse, Abgang Seite <i>Hood, side entry</i> 		32 40 50	C146 21R048 506 1 C146 21R048 507 1 C146 21R048 508 1

Verschraubung für Tüllen- und Sockelgehäuse siehe Seite 180-183 / gland bushings for hoods and housing see page 180-183
 Zubehör siehe Seite 184-186 / accessories see page 184-186



C 146 E 48 pol.
 C 146 M 14 Module
 C 146 D 128 pol.
 C 146 DD 216 pol.
 C 146 HVE 32 pol.

Gehäuse für Längsbügelverriegelung

housings for 1 locking-lever-systems

Gehäuse
 Housings

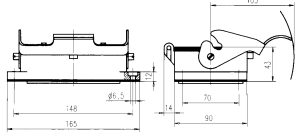
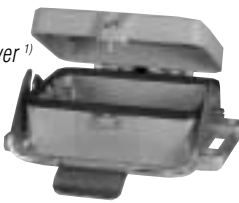
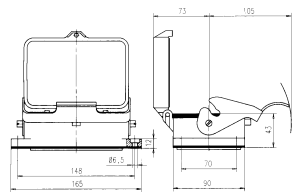
PG-Gewinde
 PG-thread

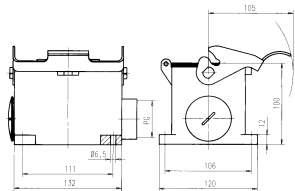
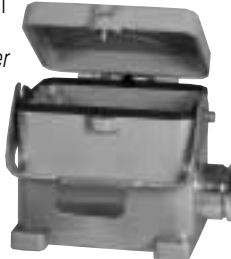
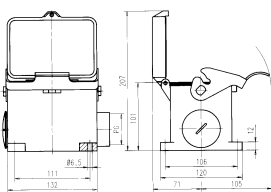
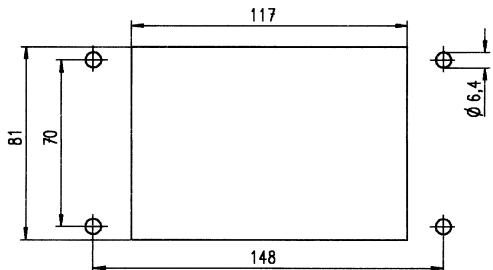
Bezeichnung - Abbildung Description - Figure	Maßzeichnung Drawing	PG	Bestell Nr. Part No.
Gehäuseunterteile / Housings			
Anbaugehäuse ¹⁾ <i>Housings, bulkhead mounting ¹⁾</i> 		–	C146 10F048 001 1
Anbaugehäuse mit Deckel ¹⁾ <i>Housings, bulkhead mounting with spring cover ¹⁾</i> 		–	C146 10F048 003 1
Sockelgehäuse, 1 Kabelabgang <i>Housing, single side entry</i> 		29	C146 10F048 802 1
		36	C146 10F048 803 1
Sockelgehäuse mit Deckel <i>Housing with spring cover</i> 		29	C146 10F048 806 1
		36	C146 10F048 807 1
Montageausschnitt für Anbaugehäuse / Panel cut out for housing bulkhead mounting			
			

¹⁾incl. Flachdichtung / incl. gasket

C 146 E 48 pol.
 C 146 M 14 Module
 C 146 D 128 pol.
 C 146 DD 216 pol.
 C 146 HVE 32 pol.

Gehäuse für Längsbügelverriegelung

housings for 1 locking-lever-systems

Gehäuse
 Housings

Metrisches Gewinde
 Metric thread

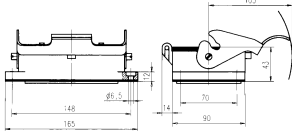
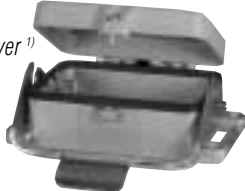
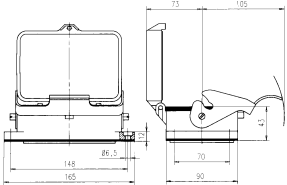
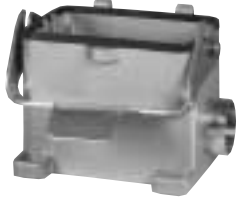
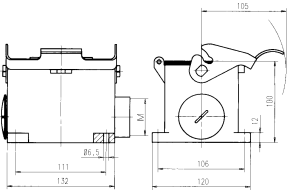
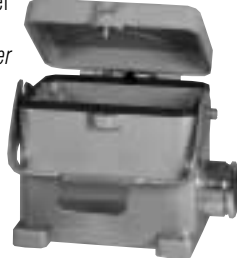
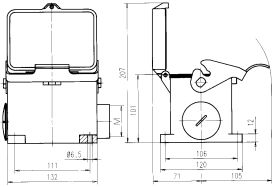
Bezeichnung - Abbildung Description - Figure	Maßzeichnung Drawing	M	Bestell Nr. Part No.
Gehäuseunterteile / Housings		mit Stützen / with stud	
Anbaugehäuse ¹⁾ <i>Housings, bulkhead mounting ¹⁾</i> 		—	C146 10F048 001 1
Anbaugehäuse mit Deckel ¹⁾ <i>Housings, bulkhead mounting with spring cover ¹⁾</i> 		—	C146 10F048 003 1
Sockelgehäuse, 1 Kabelabgang <i>Housing, single side entry</i> 		32 40	C146 10N048 802 1 C146 10N048 803 1
Sockelgehäuse mit Deckel <i>Housing with spring cover</i> 		32 40	C146 10N048 806 1 C146 10N048 807 1

¹⁾incl. Flachdichtung / incl. gasket

C 146 HvE 16 pol.

**Gehäuse für Querbügelverriegelung nach
DIN EN 175 301 - 801 (DIN 43 652)**







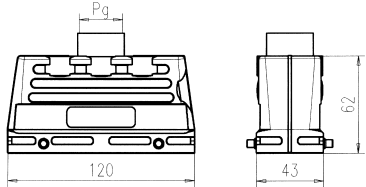

**housings for 2 locking-lever-system according to
DIN EN 175 301 - 801 (DIN 43 652)**

- mit Isolationsauskleidung
- ohne Kodiersteg

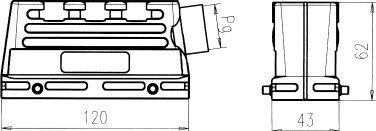
- with insulation inside
- with removed coding element

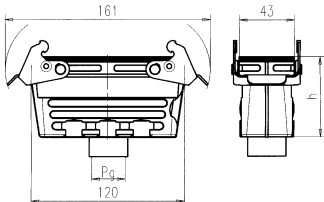
**Gehäuse
Housings**

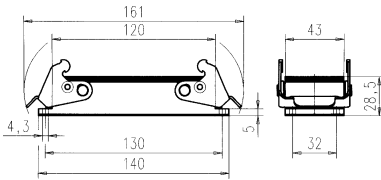
**PG-Gewinde
PG-thread**

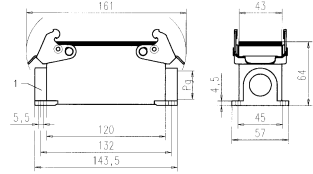
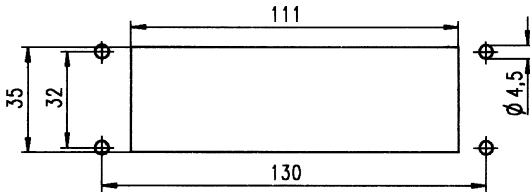
Bezeichnung - Abbildung Description - Figure	Maßzeichnung Drawing	PG	Bestell Nr. / Part No. Niedrige Bauform / Low profile
Gehäuseoberteile / Hoods			
Tüllengehäuse, Abgang oben <i>Hood, top entry</i> 		21	C146 10G024 600 3
Tüllengehäuse, Abgang Seite <i>Hood, side entry</i> 		21	C146 10G024 500 3
Gehäuseunterteile / Housings			
Kupplungsgehäuse <i>Hood, coupling application</i> 		21	C146 10G024 802 3
Anbaugehäuse ¹⁾ <i>Housing, bulkhead mounting ¹⁾</i> 		-	C146 10F024 000 3
Sockelgehäuse <i>Housing</i> 	 1 Geschlossen bei einem Kabelausgang 1 closed if single entry	21	1 Kabelabgang / <i>Single side entry</i>
			C146 10F024 500 3
Montageausschnitt für Anbaugehäuse / Panel cut out for housing bulkhead mounting			
			

¹⁾ incl. Flachdichtung / *incl. gasket* Zubehör siehe Seite 184-186 / *accessories see page 184-186*
Verschraubung für Tüllen- und Sockelgehäuse siehe Seite 180-183 / *gland bushings for hoods and housing see page 180-183*

C 146 HvE 16 pol.

**Gehäuse für Querbügelverriegelung nach
DIN EN 175 301 - 801 (DIN 43 652)**







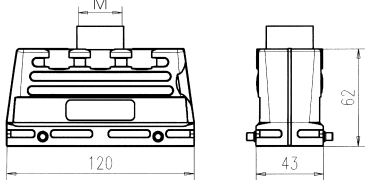

**housings for 2 locking-lever-system according to
DIN EN 175 301 - 801 (DIN 43 652)**

- mit Isolationsauskleidung
- ohne Kodiersteg

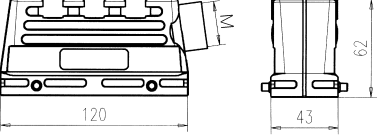
- with insulation inside
- with removed coding element

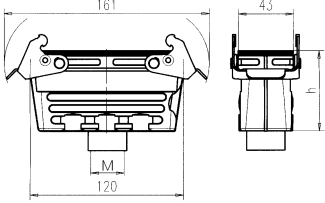
**Gehäuse
Housings**

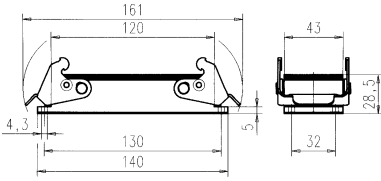
**Metrisches Gewinde
Metric thread**

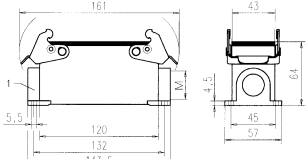
Bezeichnung - Abbildung Description - Figure	Maßzeichnung Drawing	M	Bestell Nr. / Part No. Niedrige Bauform / Low profile	
Gehäuseoberteile / Hoods				
Tüllengehäuse, Abgang oben Hood, top entry 		25	C146 10R024 650 3	
		32	C146 10R024 600 3	
Tüllengehäuse, Abgang Seite Hood, side entry 		25	C146 10R024 550 3	
		32	C146 10R024 500 3	
Gehäuseunterteile / Housings				
Kupplungsgehäuse Hood, coupling application 		25	C146 10R024 852 3	
		32	C146 10R024 802 3	
Anbaugehäuse ¹⁾ Housing, bulkhead mounting ¹⁾ 		–	C146 10F024 000 3	
		Sockelgehäuse Housing 	 <p>1 Geschlossen bei einem Kabelausgang 1 closed if single entry</p>	25

¹⁾ incl. Flachdichtung / incl. gasket Zubehör siehe Seite 184-186 / accessories see page 184-186
 Verschraubung für Tüllen- und Sockelgehäuse siehe Seite 180-183 / gland bushings for hoods and housing see page 180-183



C 146 EMV Gehäuse / *EMC* Housings



Für Serien

- C 146 E 6 - 24 pol
- C 146 D 40 - 64 pol
- C 146 M 2 - 7 Module
- C 146 HSE 6 pol

For series

- *C 146 E 6 - 24 contacts*
- *C 146 D 40 - 64 contacts*
- *C 146 M 2 - 7 Module*
- *C 146 HSE 6 contacts*

EMV-Gehäuse
EMC housings

- leitfähige Oberfläche
- Standard Verriegelungssystem
- gleiche Gehäuseabmessungen wie Standard Gehäuse
- zwei Bauhöhen
- mit und ohne Massestreifen
- hohe Dämpfungseigenschaften
- Schutzart IP 65
- Steckzyklen > 500

- *conductive surface*
- *standard locking levers*
- *same housing dimensions like standard housings*
- *two housing sizes*
- *with or without ground strap*
- *high attenuation*
- *protection class IP 65*
- *mating cycles > 500*

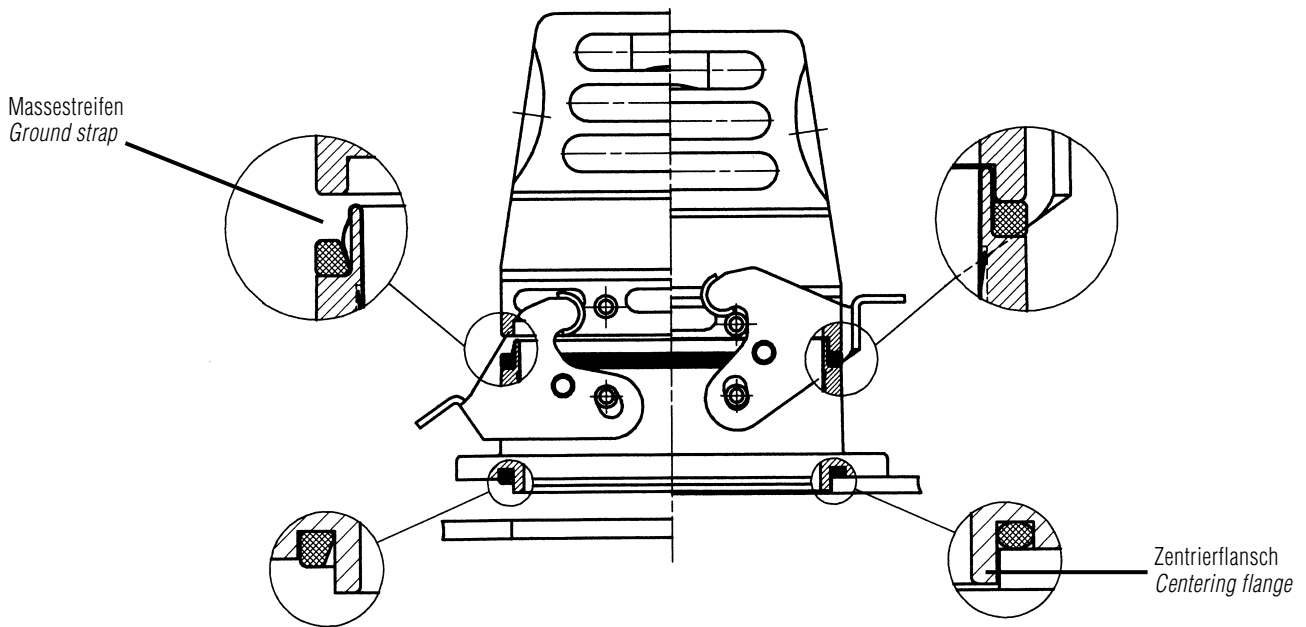

Standard Gehäuse C 146
Standard housing C 146

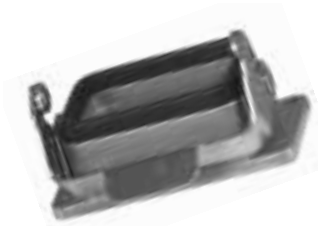

Version A Standardflansch, ohne Massestreifen
Version A Standard flange, without ground strap



Version B Standardflansch, mit Massestreifen
Version B Standard flange, with ground strap



Version C Zentrierflansch, mit Massestreifen
Version C Centering flange, with ground strap









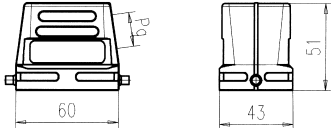

C 146 E 6 pol.
 C 146 M 2 Module
 C 146 DD 24 pol.
 C 146 EE 10 pol.

EMV-Gehäuse
 EMC housings

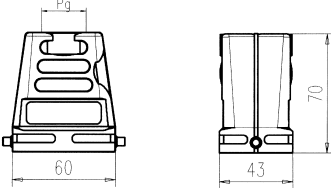
Gehäuse für Längsbügelverriegelung
 Housings for 1 locking-lever-system

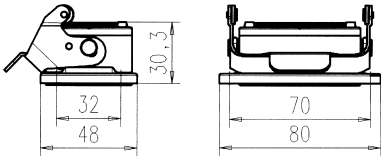
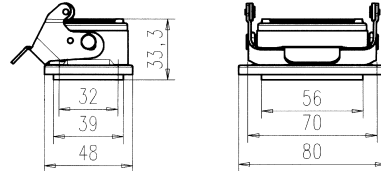
PG-Gewinde
 PG-thread

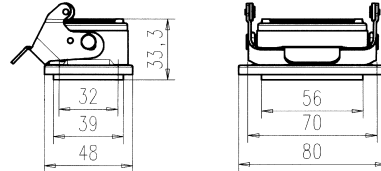
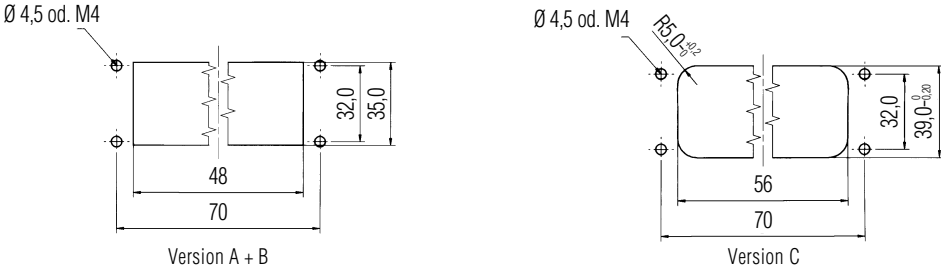
Bezeichnung - Abbildung Description - Figure	Maßzeichnung Drawing	PG	Kabelabgang Cable outlet	Bestell Nr. / Part No.	
				Niedrige Bauform Low profile	Hohe Bauform High profile
Gehäuseoberteile / Hoods					
Tüllengehäuse / Hood 		11	Seite / side	C146 11G006 556 1 C146 11G006 606 1 C146 11G006 506 1 C146 11G006 607 1 C146 11G006 507 1	
		13,5	Oben / top		
13,5	Seite / side				
16	Oben / top				
16	Seite / side				
		21	Oben / top	C146 11G006 606 8 C146 11G006 506 8 C146 11G006 607 8 C146 11G006 507 8	
		21	Seite / side		
		29	Oben / top		
		29	Seite / side		
Gehäuseunterteile / Housings					
Anbaugehäuse Housing, bulkhead mounting 	Version A + B 	A		C146 11F006 901 8 C146 11F006 902 8	
	Version C 	B			
		Version C 	C		C146 11F006 001 8
	Montageausschnitt / Panel cutout				
					



EMV Verschraubung für Tüllengehäuse siehe Seite 183 / EMC gland bushings for hoods see page 183

C 146 E 6 pol.
 C 146 M 2 Module
 C 146 DD 24 pol.
 C 146 EE 10 pol.

EMV-Gehäuse
 EMC housings

Gehäuse für Längsbügelverriegelung
 Housings for 1 locking-lever-system

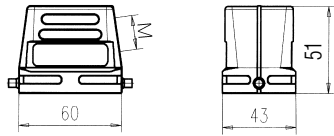
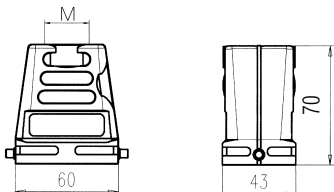
Metrisches Gewinde
 Metric thread

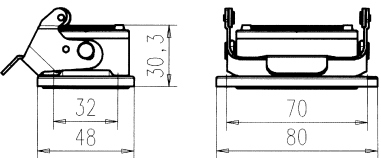
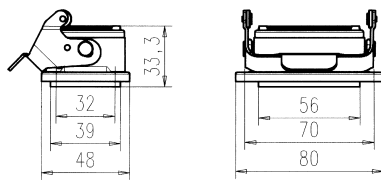
Bezeichnung - Abbildung Description - Figure	Maßzeichnung Drawing	M	Kabelabgang Cable outlet	Bestell Nr. / Part No.	
				Niedrige Bauform Low profile	Hohe Bauform High profile
Gehäuseoberteile / Hoods			ohne Stutzen / without stud		
		16	Seite / side	C146 11R006 556 1	
		20	Oben / top	C146 11R006 606 1	
		20	Seite / side	C146 11R006 506 1	
		25	Oben / top	C146 11R006 607 1	
		25	Seite / side	C146 11R006 507 1	
		25	Oben / top	C146 11R006 656 8	
		25	Seite / side	C146 11R006 556 8	
		32	Oben / top	C146 11R006 606 8	
		32	Seite / side	C146 11R006 506 8	
		Gehäuseunterteile / Housings			
Anbaugeschäuse Housing, bulkhead mounting 	Version A + B		A	C146 11F006 901 8	
		B		C146 11F006 902 8	
		Version C		C	C146 11F006 001 8
					







EMV Verschraubung für Tüllengehäuse siehe Seite 183 / EMC gland bushings for hoods see page 183

C 146 E 10 pol.
 C 146 M 3 Module
 C 146 DD 42 pol.
 C 146 EE 18 pol.

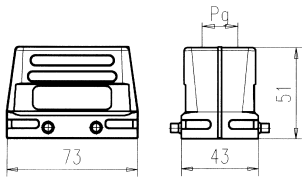
Gehäuse für Querbügelverriegelung
 Housings for 2 locking-lever-system

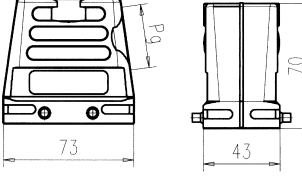
EMV-Gehäuse
 EMC housings

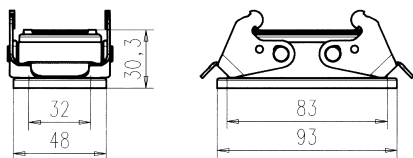
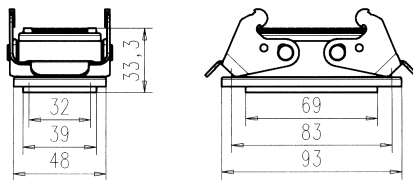
PG-Gewinde
 PG-thread

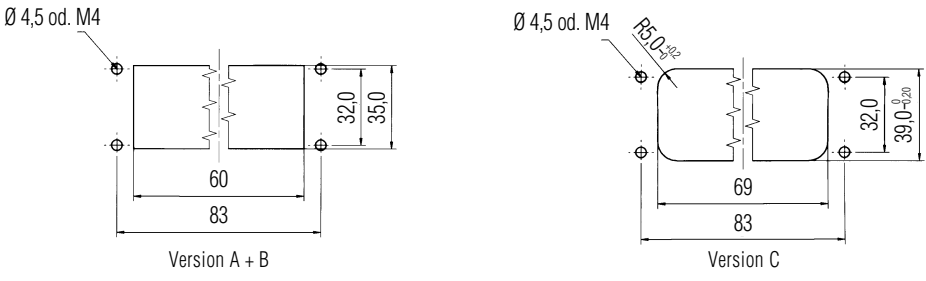
Bezeichnung - Abbildung Description - Figure	Maßzeichnung Drawing	PG	Kabelabgang Cable outlet	Bestell Nr. / Part No.	
				Niedrige Bauform Low profile	Hohe Bauform High profile
Gehäuseoberteile / Hoods					
Tüllengehäuse / Hood 		16	Oben / top	C146 11G010 600 1	
		16	Seite / side	C146 11G010 500 1	
		21	Oben / top	C146 11G010 601 1	
		21	Seite / side	C146 11G010 501 1	
		21	Oben / top	C146 11G010 600 8	
		21	Seite / side	C146 11G010 500 8	
		29	Oben / top	C146 11G010 601 8	
		29	Seite / side	C146 11G010 501 8	
Gehäuseunterteile / Housings			Version		
Anbaugehäuse Housing, bulkhead mounting 	Version A + B 		A	C146 11F010 901 8	
	Version C 		B	C146 11F010 902 8	
			C	C146 11F010 000 8	
Montageausschnitt / Panel cutout					
					







EMV Verschraubung für Tüllengehäuse siehe Seite 183 / EMC gland bushings for hoods see page 183

C 146 E 10 pol.
 C 146 M 3 Module
 C 146 DD 42 pol.
 C 146 EE 18 pol.

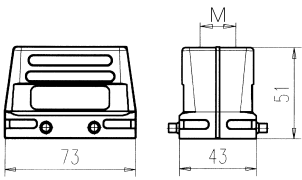
EMV-Gehäuse
 EMC housings

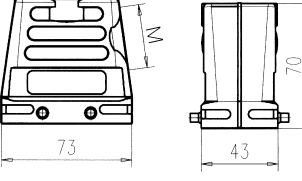
Gehäuse für Querbügelverriegelung
 Housings for 2 locking-lever-system

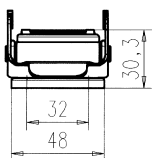
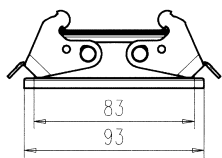
Metrisches Gewinde
 Metric thread

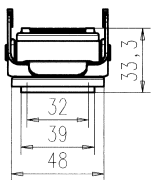
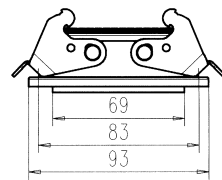
Bezeichnung - Abbildung Description - Figure	Maßzeichnung Drawing	M	Kabelabgang Cable outlet	Bestell Nr. / Part No.	
				Niedrige Bauform Low profile	Hohe Bauform High profile
Gehäuseoberteile / Hoods			ohne Stutzen / without stud		
Tüllengehäuse / Hood 		20	Oben / top	C146 11R010 650 1	
		20	Seite / side	C146 11R010 550 1	
		25	Oben / top	C146 11R010 600 1	
		25	Seite / side	C146 11R010 500 1	
		32	Oben / top	C146 11R010 601 1	
		25	Oben / top		C146 11R010 650 8
		25	Seite / side		C146 11R010 550 8
		32	Oben / top		C146 11R010 600 8
		32	Seite / side		C146 11R010 500 8
		40	Oben / top		C146 11R010 601 8
Gehäuseunterteile / Housings			Version		
Anbaugehäuse Housing, bulkhead mounting 	Version A + B 		A	C146 11F010 901 8	
			B	C146 11F010 902 8	
	Version C 		C	C146 11F010 000 8	
					





EMV Verschraubung für Tüllengehäuse siehe Seite 183 / EMC gland bushings for hoods see page 183

C 146 E 16 pol.
 C 146 M 5 Module
 C 146 D 40 pol.
 C 146 DD 72 pol.
 C 146 HSE 6 pol.
 C 146 EE 32 pol.

EMV-Gehäuse
 EMC housings

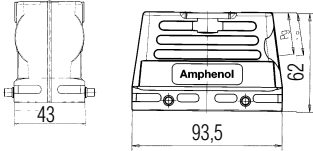
Gehäuse für Querbügelverriegelung
 Housings for 2 locking-lever-system

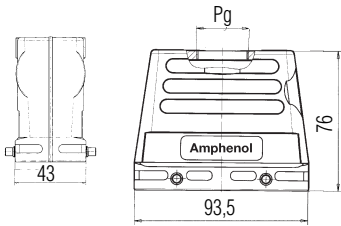
PG-Gewinde
 PG-thread

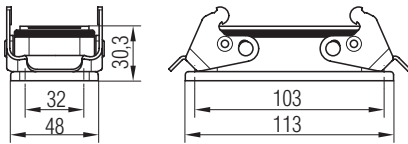
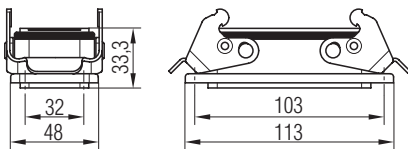
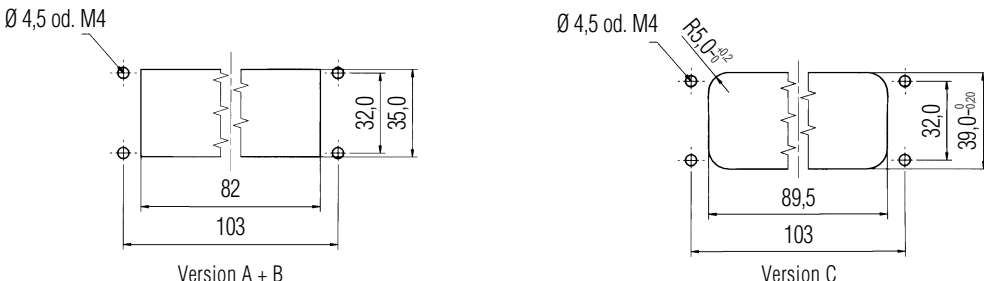
Bezeichnung - Abbildung Description - Figure	Maßzeichnung Drawing	PG	Kabelabgang Cable outlet	Bestell Nr. / Part No.	
				Niedrige Bauform Low profile	Hohe Bauform High profile
Gehäuseoberteile / Hoods					
Tüllengehäuse / Hood 		21	Oben / top	C146 11G016 600 1 C146 11G016 500 1 C146 11G016 601 1 C146 11G016 501 1	
		21	Seite / side		
		29	Oben / top		
		29	Seite / side		
		21	Oben / top	C146 11G016 600 8 C146 11G016 500 8 C146 11G016 601 8 C146 11G016 501 8	
		21	Seite / side		
		29	Oben / top		
		29	Seite / side		
Gehäuseunterteile / Housings			Version		
Anbaugehäuse Housing, bulkhead mounting 	Version A + B 	A	C146 11F016 901 8		
	Version C 	B	C146 11F016 902 8		
		C	C146 11F016 000 8		
Montageausschnitt / Panel cutout					
					







EMV Verschraubung für Tüllengehäuse siehe Seite 183 / EMC gland bushings for hoods see page 183

C 146 E 16 pol.
 C 146 M 5 Module
 C 146 D 40 pol.
 C 146 DD 72 pol.
 C 146 HSE 6 pol.
 C 146 EE 32 pol.

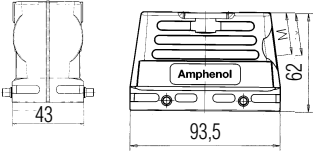
EMV-Gehäuse
 EMC housings

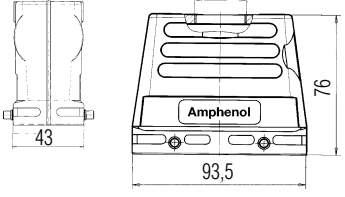
Gehäuse für Querbügelverriegelung
 Housings for 2 locking-lever-system

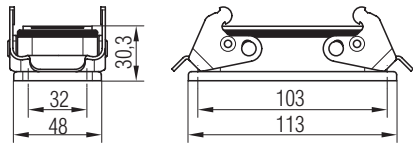
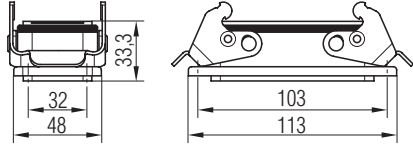
Metrisches Gewinde
 Metric thread

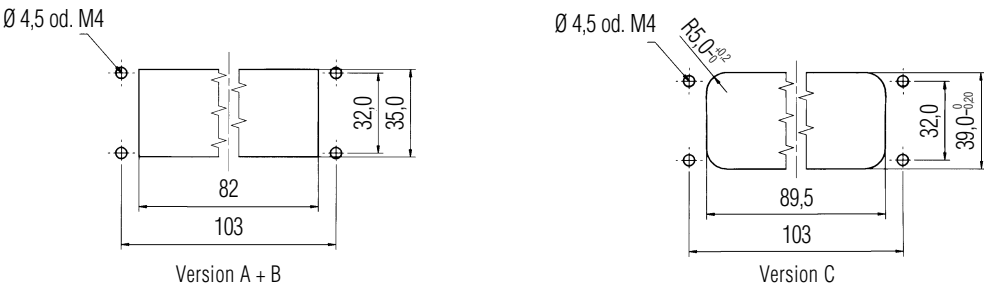
Bezeichnung - Abbildung Description - Figure	Maßzeichnung Drawing	M	Kabelabgang Cable outlet	Bestell Nr. / Part No.	
				Niedrige Bauform Low profile	Hohe Bauform High profile
Gehäuseoberteile / Hoods					
Tüllengehäuse / Hood 		25	Oben / top	C146 11R016 650 1	
		25	Seite / side	C146 11R016 550 1	
		32	Oben / top	C146 11R016 600 1	
		32	Seite / side	C146 11R016 500 1	
		25	Oben / top		C146 11R016 650 8
		25	Seite / side		C146 11R016 550 8
		32	Oben / top		C146 11R016 600 8
		32	Seite / side		C146 11R016 500 8
		40	Oben / top		C146 11R016 601 8
		40	Seite / side		C146 11R016 501 8
Gehäuseunterteile / Housings			Version		
Anbaugehäuse Housing, bulkhead mounting 	Version A + B 		A	C146 11F016 901 8	
	Version C 		B	C146 11F016 902 8	
			C	C146 11F016 000 8	
Montageausschnitt / Panel cutout					
 <p>Ø 4,5 od. M4</p> <p>Version A + B</p> <p>Version C</p>					



EMV Verschraubung für Tüllengehäuse siehe Seite 183 / EMC gland bushings for hoods see page 183

C 146 E 24 pol.
 C 146 M 7 Module
 C 146 D 64 pol.
 C 146 DD 108 pol.
 C 146 EE 46 pol.

EMV-Gehäuse
 EMC housings

Gehäuse für Querbügelverriegelung
 Housings for 2 locking-lever systems

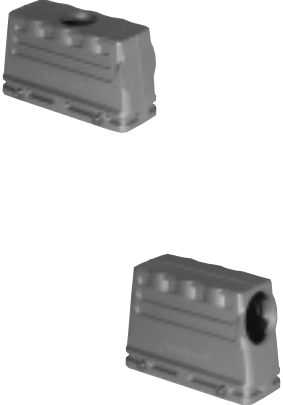
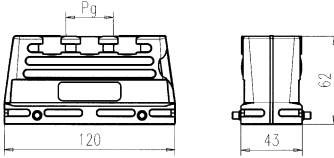
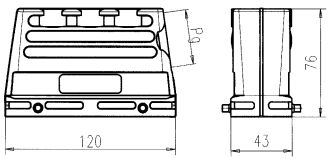
PG-Gewinde
 PG-thread

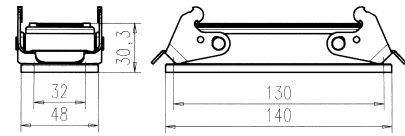
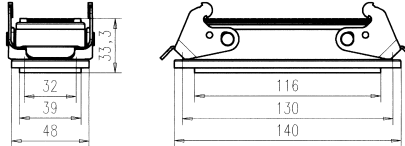
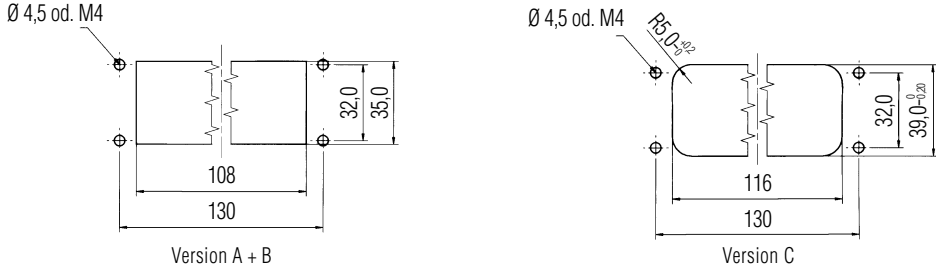
Bezeichnung - Abbildung Description - Figure	Maßzeichnung Drawing	PG	Kabelabgang Cable outlet	Bestell Nr. / Part No.	
				Niedrige Bauform Low profile	Hohe Bauform High profile
Gehäuseoberteile / Hoods					
Tüllengehäuse / Hood 		21	Oben / top	C146 11G024 600 1	
		21	Seite / side	C146 11G024 500 1	
		29	Oben / top	C146 11G024 601 1	
		29	Seite / side	C146 11G024 501 1	
		21	Oben / top		C146 11G024 600 8
		21	Seite / side		C146 11G024 500 8
		29	Oben / top		C146 11G024 601 8
		29	Seite / side		C146 11G024 501 8
Gehäuseunterteile / Housings					
Anbaugehäuse Housing, bulkhead mounting 	Version A + B		A	C146 11F024 901 8	
			B	C146 11F024 902 8	
	Version C		C	C146 11F024 000 8	
					
Montageausschnitt / Panel cutout					
					





EMV Verschraubung für Tüllengehäuse siehe Seite 183 / EMC gland bushings for hoods see page 183

C 146 E 24 pol.
 C 146 M 7 Module
 C 146 D 64 pol.
 C 146 DD 108 pol.
 C 146 EE 46 pol.

EMV-Gehäuse
 EMC housings

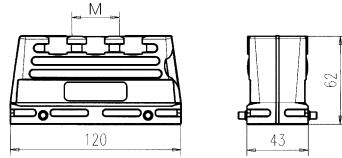
Gehäuse für Querbügelverriegelung
 Housings for 2 locking-lever systems

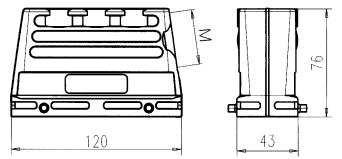
Metrisches Gewinde
 Metric thread

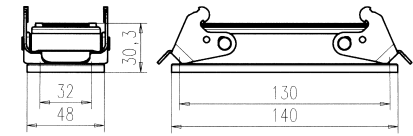
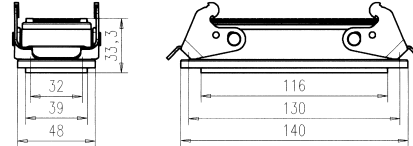
Bezeichnung - Abbildung Description - Figure	Maßzeichnung Drawing	M	Kabelabgang Cable outlet	Bestell Nr. / Part No.				
				Niedrige Bauform Low profile	Hohe Bauform High profile			
Gehäuseoberteile / Hoods								
Tüllengehäuse / Hood 		25	Oben / top	C146 11R024 650 1 C146 11R024 550 1 C146 11R024 600 1 C146 11R024 500 1				
		25	Seite / side					
		32	Oben / top					
		32	Seite / side					
		40	Oben / top	C146 11R024 650 8 C146 11R024 550 8 C146 11R024 600 8 C146 11R024 500 8 C146 11R024 601 8 C146 11R024 501 8				
		40	Seite / side					
		Gehäuseunterteile / Housings						
		Anbaugeschäse Housing, bulkhead mounting 	Version A + B		A	C146 11F024 901 8	C146 11F024 902 8	
Version C	B		C146 11F024 000 8					
			C	C146 11F024 000 8				
								

EMV Verschraubung für Tüllengehäuse siehe Seite 183 / EMC gland bushings for hoods see page 183



C 146 Zubehör / *Accessories*





Übersicht





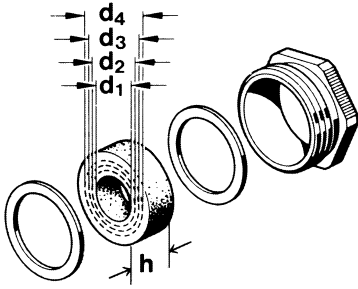

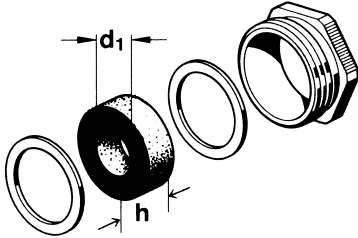

- Verschraubungen
- EMV Verschraubungen
- Verschraubungen mit Zugentlastung
- Codierbolzen
- Führungsstifte / Buchsen
- D-Sub Adapterplatten
- Moosgummidichtungen
- Klebeschild nach CSA-Vorschrift

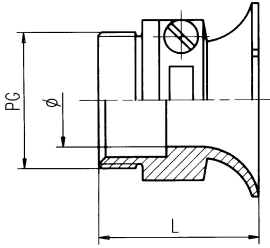
Overview

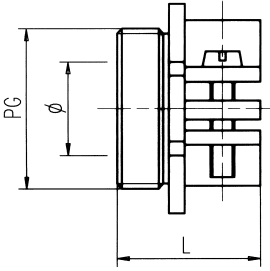
- *gland bushings*
- *EMC gland bushings*
- *Cable seals with cable clamp*
- *Key pin*
- *Guide pin / bush*
- *D-Sub adaptors*
- *Foam rubber sealing*
- *Label for CSA regulation*

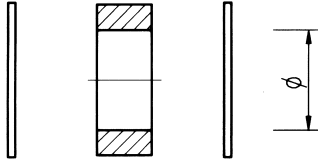
Bezeichnung - Abbildung Description - Figure	Zeichnung Drawing	PG PG	M M	Stückzahl Pieces	Bestell Nr. Part No.
Metall, mit ausschneidbaren Dichtungen (Zwiebelringen) Metal, with variable inner diameter 		11	-	10	VN16 110 0014 X (Thermoplast)
		-	20	10	VN16 200 0114 X (Thermoplast)
		13,5	-	10	VN16 135 0014 X
		16	-	10	VN16 160 0014 X
		-	20	10	VN16 200 0114 X
		21	-	10	VN16 210 0014 X
		-	25	10	VN16 250 0114 X
		29	-	10	VN16 290 0014 X
		-	32	10	VN16 320 0114 X
		36	-	10	VN16 360 0014 X
		-	40	10	VN16 400 0114 X
		-	42	10	VN16 420 0014 X
-	50	10	VN16 500 0114 X		
Metall, mit Standard Dichtung Metal, with standard diameter 		11	-	10	VN16 110 0013 X (Thermoplast)
		13,5	-	10	VN16 135 0013 X
		16	-	10	VN16 160 0013 X
		21	-	10	VN16 210 0013 X
		29	-	10	VN16 290 0013 X
		36	-	10	VN16 360 0013 X
42	-	10	VN16 420 0013 X		

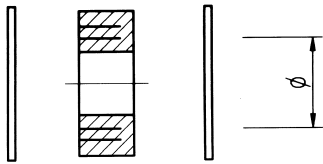
¹⁾ Achtung: nicht für Gehäuse ohne Stutzen geeignet / Attention: not usable for hoods without stud

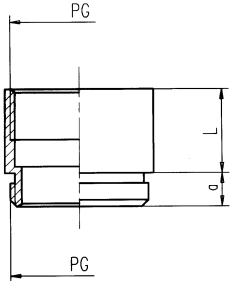
Bezeichnung - Abbildung Description - Figure	Zeichnung Drawing	PG PG	M M	Stückzahl Pieces	Bestell Nr. Part No.
Kabelverschraubung ohne Dichtung Cable clamp without gasket 		11	-	5	VN16 110 0004 V (Thermoplast)
		13,5	-	5	VN16 135 0002 V
		- 16	-	5	VN16 160 0102 V
		16	-	5	VN16 160 0002 V
		- 20	-	5	VN16 200 0102 V
		21	-	5	VN16 210 0002 V
		- 25	-	5	VN16 250 0102 V
		29	-	5	VN16 290 0002 V
- 32	-	5	VN16 320 0102 V		
Kabelverschraubung ohne Dichtung Cable clamp without gasket 		13,5	-	5	VN16 135 0003 V
		16	-	5	VN16 160 0003 V
		- 20	-	5	VN16 200 0103 V
		21	-	5	VN16 210 0003 V
		- 25	-	5	VN16 250 0103 V
		29	-	5	VN16 290 0003 V
- 32	-	5	VN16 320 0103 V		
Dichtung, Druckscheibe Sealing, pressure disk 		11	-	10	VN16 110 0028 X
		13,5	-	10	VN16 135 0028 X
		16	-	10	VN16 160 0028 X
		21	-	10	VN16 210 0028 X
29	-	10	VN16 290 0028 X		
Ausschneidbare Dichtung, Druckscheibe Sealing with variable inner diameter, and pressure rings 		11	-	10	VN16 110 0029 X
		13,5	-	10	VN16 135 0029 X
		16	-	10	VN16 160 0029 X
		21	-	10	VN16 210 0029 X
29	-	10	VN16 290 0029 X		
Zwischenstutzen Stud 		11	-	1	N16 011 0010
		13,5	-	1	N16 013 0010
		16	-	1	N16 016 0010
		21	-	1	N16 021 0010
		29	-	1	N16 029 0010

¹⁾ Achtung: nicht für Gehäuse ohne Stutzen geeignet / Attention: not usable for hoods without stud

Verschraubung IP 67 (Material PA / - 20 °C + 80 °C)
Gland bushings IP 67 (Material PA / - 20 °C + 80 °C)

Bezeichnung - Abbildung Description - Figure	Klemmbereich Ø Clamping range Ø	A mm	PG PG	M M	Stückzahl Pieces	Bestell Nr. / Part No.
	4 - 10 mm	24,4	11	-	10	VN16 110 0027 X
	4 - 10 mm	20	-	16	10	VN16 160 0127 X
	5 - 12 mm	26,5	13,5	-	10	VN16 135 0027 X
	6 - 12 mm	24	-	20	10	VN16 200 0127 X
	9 - 14 mm	29,5	16	-	10	VN16 160 0027 X
	9 - 16 mm	28	-	25	10	VN16 250 0127 X
	13 - 18 mm	36,2	21	-	10	VN16 210 0027 X
	10 - 21 mm	36	-	32	10	VN16 320 0127 X
	14 - 25 mm	43,6	29	-	10	VN16 290 0027 X
16 - 28 mm	46	-	40	10	VN16 400 0127 X	

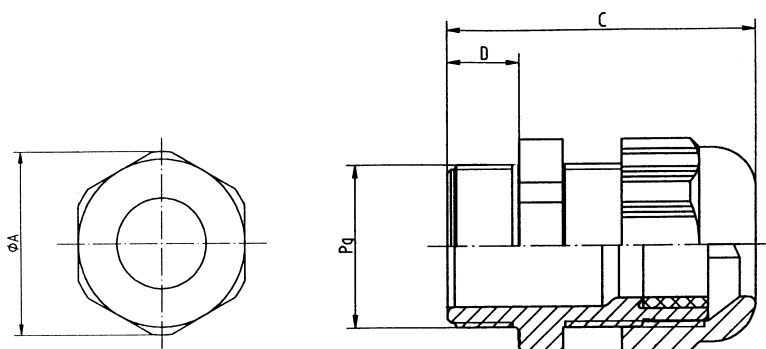

Blindstopfen aus Messing vernickelt mit Einstich und O-Ring Plugs brass nickel-plated with recess and o-ring			M 20	10	VN16 020 0113 (1) X
			M 25	10	VN16 025 0113 (1) X
			M 32	10	VN16 032 0113 (1) X
			M 40	10	VN16 040 0113 (1) X

EMV Verschraubung IP 68 (Material CuZn / PA / - 20 °C + 80 °C)
EMC gland bushings IP 68 (Material CuZn / PA / - 20 °C + 80 °C)

Bezeichnung - Abbildung Description - Figure	Klemmbereich F Clamping range F	PG PG	M M	Stückzahl Pieces	Bestell Nr. Part No.
Kabelverschraubung EMV Gland bushing EMC 	4 - 10 mm	11	–	10	VN16 110 0026 X
	5,5 - 10 mm	–	16	10	VN16 160 0126 X
	5 - 12 mm	13,5	–	10	VN16 135 0026 X
	8 - 13 mm	–	20	10	VN16 200 0126 X
	8 - 14 mm	16	–	10	VN16 160 0026 X
	11 - 18 mm	–	25	10	VN16 250 0126 X
	11 - 17,5 mm	21	–	10	VN16 210 0026 X
	15 - 21 mm	–	32	10	VN16 320 0126 X
	16 - 25 mm	29	–	10	VN16 290 0026 X
19 - 27 mm	–	40	10	VN16 400 0126 X	

Montagehinweise für metrische Verschraubung / Assembly instructions for metric clamp

- Der Außenmantel des Kabels wird entfernt bis Unterseite Lamellen-Klemmkäfig, das Drahtgeflecht wird erst ein Stück weiter unten abgeschnitten und dann als ringförmiger Wulst ausgebildet. Der innere Schutzmantel kann am Kabel dranbleiben, sofern er durch die untere Öffnung der Verschraubung passt.
- Bei der Montage, beim Zusammenschrauben der Kabelverschraubung wird der ringförmige Wulst durch die Lamellentülle auf den Boden des Unterteils verpresst und findet in einer Auskofferung Platz. Dadurch wird die EMV-Sicherheit hergestellt.
- The cable jacket should be removed as far as the underside of the cable clamping; the wire netting is then to be cut down a little further and subsequently must be formed into a circular rim. The protective jacket can remain attached to the cable provided that it passes through the lower opening of the clamp.
- On assembly, while screwing the cable clamp, the circular rim has to be pushed through and pressed on the fins commutator on the base of the underside and settle into a depression. By doing this the EMC security will remain.

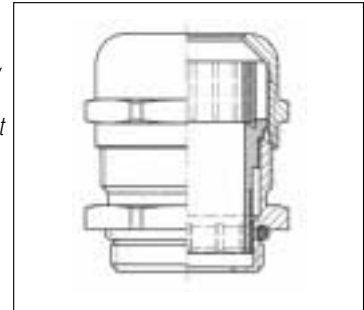





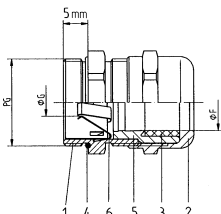
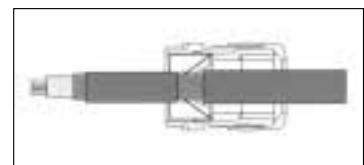
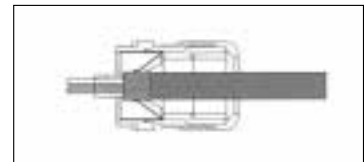
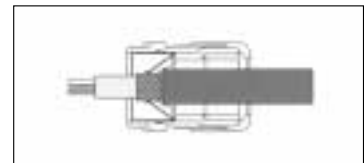

Montagehinweise für PG-Verschraubung / Assembly instructions for PG-Clamp

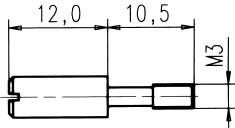
- Außenmantel und Schirm absetzen
- Außenmantel nach ca. 15 mm mit Rundschnitt versehen, jedoch nicht abziehen
- Leitung durch die Verschraubung führen
- Außenmantel abziehen
- Leitung zurückziehen bis die Verbindung zwischen Leitungsschirm und Kontaktfeder hergestellt ist
- Außenmantel absetzen
- Schirmgeflecht ca. 15 - 20 mm über den Außenmantel zurückschlagen
- Leitungen in Verschraubung einführen, bis Verbindung zwischen Leitungsschirm und Kontaktfeder hergestellt ist
- Schirmgeflecht ca. 10 mm freilegen
- Leitung durch die Verschraubung führen bis Verbindung zwischen Leitungsschirm und Kontaktfeder hergestellt ist
- Cut and remove cable jacket and braid
- Cut cable jacket appr. 15 mm further but don't remove it yet
- Insert cable through backshell
- Remove now the cut jacket part
- Pull back cable until connection is made between grounding fingers and braid
- Cut and remove cable jacket
- Fold braid appr. 15 to 20 mm back over jacket
- Insert cable into backshell until grounding fingers connect with braid
- Expose braid appr. 10 mm
- Insert cable through backshell until grounding fingers rest on braid

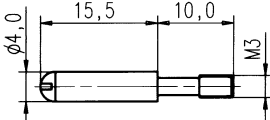

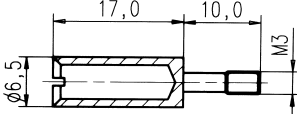
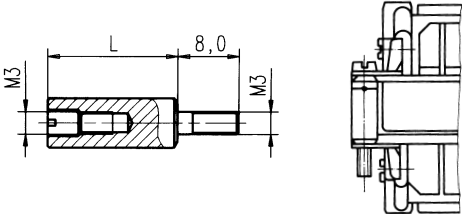

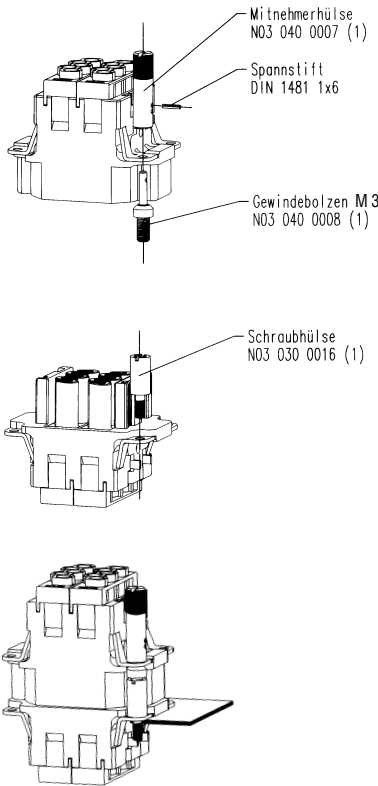

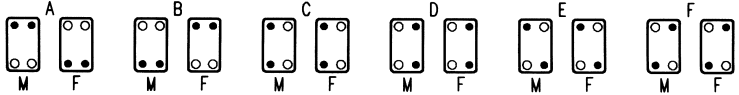
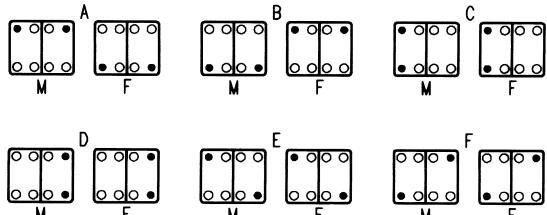
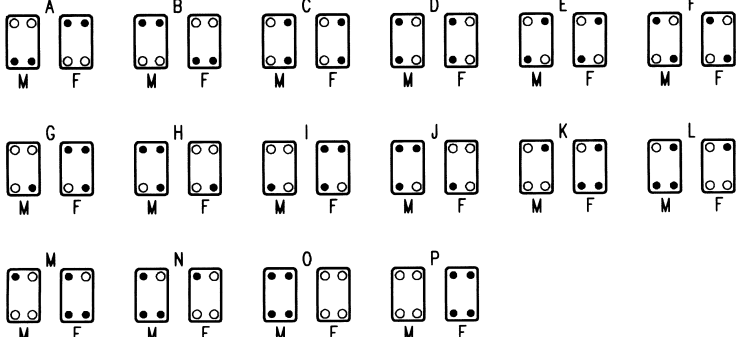
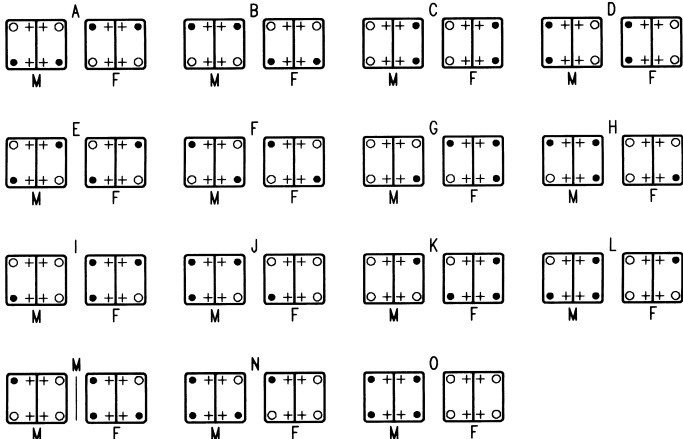

- | | |
|---------------------|----------------------|
| 1 = Zwischenstutzen | 1 = Screwed gland |
| 2 = Hutmutter | 2 = Cap nut |
| 3 = Dichtung | 3 = Sealing |
| 4 = O-Ringe | 4 = O ring |
| 5 = Einsatz | 5 = Insert |
| 6 = Erdungsfinger | 6 = Grounding finger |

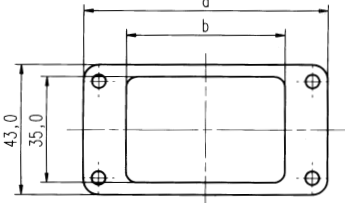
Bezeichnung - Abbildung Description - Figure	Zeichnung Drawing	Stückzahl Pieces	Bestell Nr. Part No.
Kodierbolzen mit Sicherungsscheibe Key pin with lock washer 		10 100	VN17 050 0004 (1) VN17 050 0004 (101)
Führungsstift Guide pin 		10	VN13 040 0009 (1) X
Führungsbuchse Guide socket 		10	VN13 040 0008 (1) X
Verriegelungsschraube für Kontakteinsätze Locking screw for contact inserts C146 D 15, 25 C146 A 10, 16		L 23	VN03 030 0021
Verriegelungsschraube für Kontakteinsätze Locking screw for contact inserts C146 E; M; D 40, 64; H		20	VN03 030 0020
Verriegelungsset Locking set C146 E; M; D 40, 64; H 		10	VN03 030 3000 X

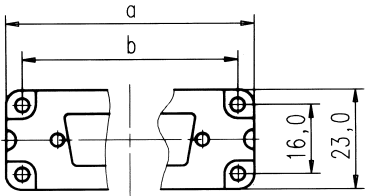
Kodierschema
Polarization system

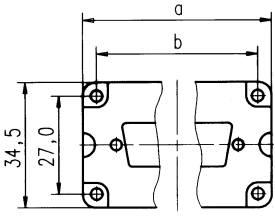
Bezeichnung Description	
<p>Kodierschema mit Kodierbolzen <i>Polarization system with key pin</i></p>	<p>Für Gehäuse mit einem Kontakteinsatz <i>For housings with one contact insert</i></p>  <p>Für Gehäuse mit zwei Kontakteinsätzen <i>For housings with two contact inserts</i></p>  <ul style="list-style-type: none"> ● Kodierbolzen ○ Befestigungsschrauben M - Stifteinsatz F - Buchseneinsatz <ul style="list-style-type: none"> ● Key pin ○ Locking screw M - Male insert F - Female insert
<p>Kodierschema mit Führungsstift und Führungsbuchse <i>Polarization system with guide pin and guide socket</i></p>	<p>Für Gehäuse mit einem Kontakteinsatz <i>For housings with one contact insert</i></p>  <p>Für Gehäuse mit zwei Kontakteinsätzen <i>For housings with two contact inserts</i></p>  <ul style="list-style-type: none"> ● Führungsstift ○ Führungsbuchse + Befestigungsschrauben M - Stifteinsatz F - Buchseneinsatz <ul style="list-style-type: none"> ● Guide pin ○ Guide socket + Locking screw M - Male insert F - Female insert

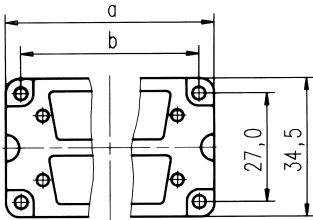
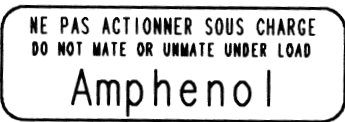
Bezeichnung - Abbildung Description - Figure	Zeichnung Drawing	Größe Size			Bestell Nr. Part No.
<p>Moosgummidichtung 2 mm Foam rubber sealing 2 mm</p> 		a 80	b 70	6	N06 080 0003 1
		93	83	10	N06 080 0003 2
		113	103	16	N06 080 0003 3
		140	130	24	N06 080 0003 4
<p>Adapterplatte D-Sub Set Metall Adaptor for D-Sub Set metal</p> 	 <p>2 x Platte / adaptor 4 x M3 x 6,5 8 x M3 x 14</p>	a 57	b 49,5	D-Sub 15	C146 N32 015 G2
		57	49,5	25	C146 N32 025 G2
<p>Adapterplatte D-Sub Set einreihig Adaptor for D-Sub set single-row</p> 	 <p>2 x Platte / adaptor 4 x M3 x 6,5 8 x M3 x 14</p>	a 51,5	b 44	D-Sub 9	C146 N32 009 G1
		51,5	44	15	C146 N32 015 G1
		64,5	57	25	C146 N32 025 G1
		85	77,5	37	C146 N32 037 G1
		85	77,5	50	C146 N32 050 G1
<p>Adapterplatte D-Sub Set zweireihig Adaptor for D-Sub set double-row</p> 	 <p>2 x Platte / adaptor 4 x M3 x 6,5 8 x M3 x 14</p>	a 51,5	b 44	D-Sub 9	C146 N33 009 G1
		51,5	44	15	C146 N33 015 G1
		64,5	57	25	C146 N33 025 G1
		85	77,5	37	C146 N33 037 G1
		85	77,5	50	C146 N33 050 G1
<p>Hinweisschild für CSA-Anwendung Label for CSA application</p>				50 Stück Pieces	N07 045 0001 L

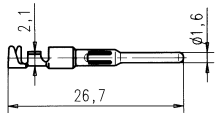
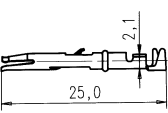
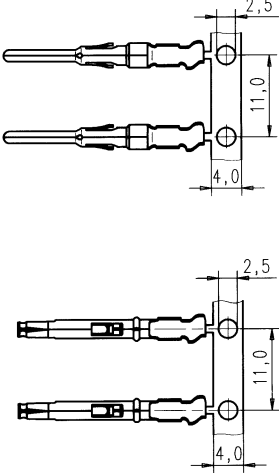
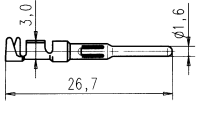
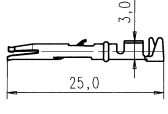
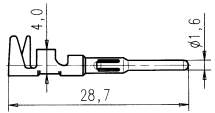
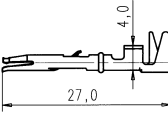
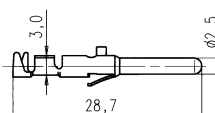
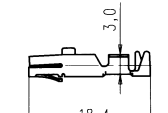
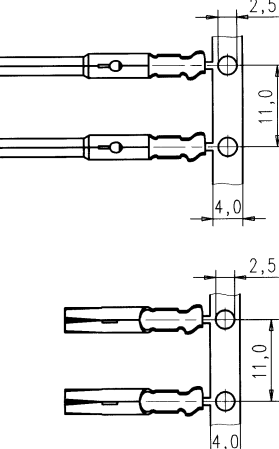
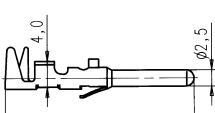
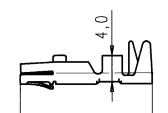
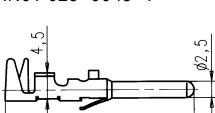
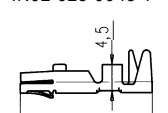
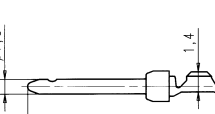
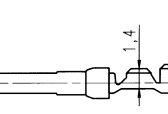
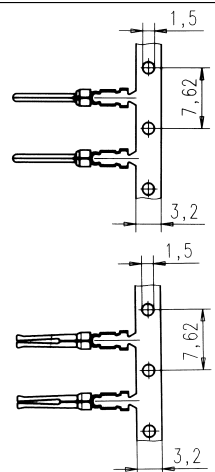
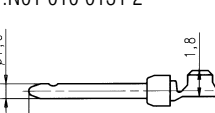
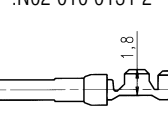
Serie Series	Maßzeichnung Einzelkontakt Drawing single contact		Maßzeichnung Bandkontakt Drawing contacts on reel
C146 D, M	.N01 016 0003 1 	.N02 016 0003 1 	
	.N01 016 0002 1 .N01 016 0015 1 ¹⁾ 	.N02 016 0002 1 .N02 016 0015 1 ¹⁾ 	
	.N01 016 0005 1 .N01 016 0016 1 ¹⁾ 	.N02 016 0005 1 .N02 016 0016 1 ¹⁾ 	
C146 E, M	.N01 025 0001 1 	.N02 025 0001 1 	
	.N01 025 0010 1 	.N02 025 0010 1 	
	.N01 025 0043 1 	.N02 025 0043 1 	
C146 M	.N01 010 0130 2 	.N02 010 0130 2 	
	.N01 010 0131 2 	.N02 010 0131 2 	

¹⁾ gekennzeichnet mit „H“ / marked with „H“

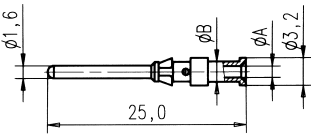
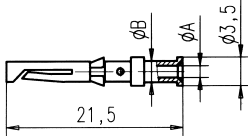
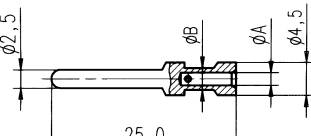
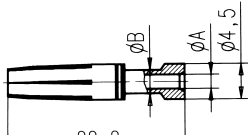
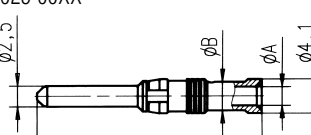
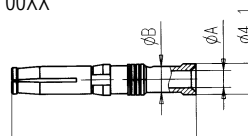
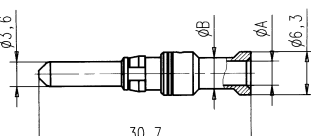
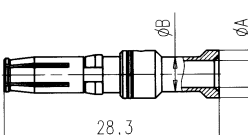
Serie Series	Maßzeichnung Drawing	Querschnitt Wire gauge	A	B	Stückzahl Pieces	Bestell Nr. Part No.
C146 D, DD, M	.N01 016 002X 	0,14 - 0,37	0,9	2,6	100	VN01 016 0024 (1)C
		0,5	1,1	2,6	100	VN01 016 0025 (1)C
		0,75 - 1,0	1,45	2,6	100	VN01 016 0026 (1)C
		1,5	1,75	3,0	100	VN01 016 0027 (1)C
		2,5	2,25	3,2	100	VN01 016 0028 (1)C
	.N02 016 002X 	0,14 - 0,37	0,9	2,6	100	VN02 016 0024 (1)C
		0,5	1,1	2,6	100	VN02 016 0025 (1)C
		0,75 - 1,0	1,45	2,6	100	VN02 016 0026 (1)C
		1,5	1,75	3,0	100	VN02 016 0027 (1)C
		2,5	2,25	3,2	100	VN02 016 0028 (1)C
C146 E, EE	.N01 025 003X 	0,5	1,1	2,6	100	VN01 025 0035 (1)C
		0,75 - 1,0	1,45	2,6	100	VN01 025 0036 (1)C
		1,5	1,75	3,0	100	VN01 025 0037 (1)C
		2,5	2,3	3,2	100	VN01 025 0038 (1)C
		4,0	2,9	4,0	100	VN01 025 0039 (1)C
	.N02 025 003X 	0,5	1,1	2,6	100	VN02 025 0035 (1)C
		0,75 - 1,0	1,45	2,6	100	VN02 025 0036 (1)C
		1,5	1,75	3,0	100	VN02 025 0037 (1)C
		2,5	2,3	3,2	100	VN02 025 0038 (1)C
		4,0	2,9	4,0	100	VN02 025 0039 (1)C
C146 M	.N01 025 00XX 	0,5	1,1	2,6	100	VN01 025 0029 (1)C
		0,75 - 1,0	1,45	2,6	100	VN01 025 0030 (1)C
		1,5	1,75	3,0	100	VN01 025 0031 (1)C
		2,5	2,25	3,45	100	VN01 025 0032 (1)C
		4,0	2,85	3,9	100	VN01 025 0033 (1)C
	.N02 025 00XX 	0,5	1,1	2,6	100	VN02 025 0029 (1)C
		0,75 - 1,0	1,45	2,6	100	VN02 025 0030 (1)C
		1,5	1,75	3,0	100	VN02 025 0031 (1)C
		2,5	2,25	3,45	100	VN02 025 0032 (1)C
		4,0	2,85	3,9	100	VN02 025 0033 (1)C
	.N01 036 000X 	1,5	1,75	3,0	100	VN01 036 0004 (1)C
		2,5	2,25	3,45	100	VN01 036 0005 (1)C
		4,0	2,85	3,9	100	VN01 036 0001 (1)C
		6,0	3,55	4,9	100	VN01 036 0002 (1)C
		10,0	4,4	5,9	100	VN01 036 0003 (1)C
	.N02 036 000X 	1,5	1,75	3,0	100	VN02 036 0004 (1)C
2,5		2,25	3,45	100	VN02 036 0005 (1)C	
4,0		2,85	3,9	100	VN02 036 0001 (1)C	
6,0		3,55	4,9	100	VN02 036 0002 (1)C	
10,0		4,4	5,9	100	VN02 036 0003 (1)C	

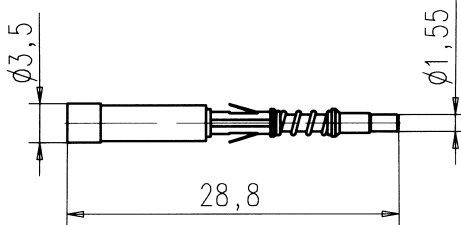
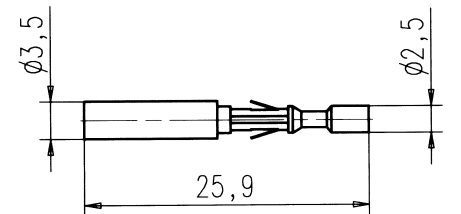
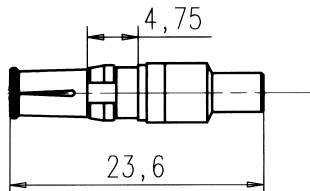
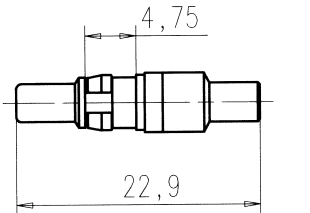
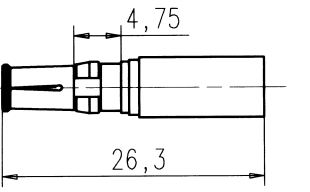
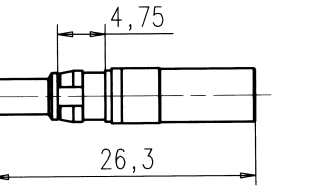
Serie Series	Maßzeichnung Einzelkontakt Drawing single contact	Bestell Nr. Part No.
C146 M LWL C146 M FO		N01 016 0040 8
		N02 016 0040 8
C146 M Koax C146 M Coax		17 DM 537 421
		17 DM 537 401
		17 DM 537 425
		17 DM 537 405





Ausführung Style	gekapselt enclosed	ungekapselt unenclosed	Schutzleiter protective earthing contact	Zugentastung cable clamp	Fingersicherheit gesteckt finger safety mated	Fingersicherheit ungesteckt finger safety unmated	Handrücken- sicherheit gesteckt hand back safety mated	Steckverbinder mit Schaltleistung ¹⁾ Connector with breaking capacity ¹⁾	Wiederanschließbar rewirable	Zugentlastung Cable clamp	
										mit ²⁾ with	ohne ³⁾ without
Tüllengehäuse mit Stifteinsatz <i>Hood with pin insert</i>	X		X		X		X	X	X	X	X
Stifteinsatz <i>Pin insert</i>		X	X					X	X	4)	X
Tüllengehäuse mit Buchseinsatz <i>Hood with socket insert</i>	X		X		X	X	X	X	X	X	X
Buchseinsatz <i>socket insert</i>		X	X					X	X	4)	X
Kupplungsgehäuse mit Stifteinsatz <i>Coupling housing with pin insert</i>	X		X		X			X	X	X	X
Kupplungsgehäuse mit Buchseinsatz <i>Coupling housing with socket insert</i>	X		X		X	X	X	X	X	X	X
Anbau-Sockelgehäuse mit Stifteinsatz <i>Housing with pin insert</i>	X		X		X		X	X	X	X	X
Anbau-Sockelgehäuse mit Buchseinsatz <i>Housing with socket insert</i>	X		X		X	X	X	X	X	X	X

¹⁾ Bei Verwendung als Steckverbinder mit Schaltleistung ist der Strom zu begrenzen / When used as connector with braking capacity the load shall be reduced

²⁾ Bei Verwendung von Kabelverschraubungen (siehe Seite 179) / When using cable seals (see page 179)

³⁾ Bei Standard Verschraubung / When using standard gland bushings

⁴⁾ siehe Einzelangaben / see detail information

Sofern nicht anders angegeben, sind zur Sicherstellung der Schutzleiterfunktion die Kontakteinsätze in metallisch leitende Gehäuse einzubauen, bzw. auf Schienen oder Montageplatten zu montieren.

If not otherwise stated the contact inserts have to be mounted in metallic conductive housings resp. on bars or mounting boards to complete the protective earth grounding.

! Allgemeine technische Informationen

Hinweise:

- Die Sicherheit von Steckverbindern/Steckverbinder mit Schaltleistung (Steckvorrichtung) ist abhängig von der richtigen Auswahl der Produkte, dem ordnungsgemäßen Einbau und der sachgemäßen Montage.
- Verbindlich für den Einsatz von Steckverbindern sind die jeweiligen Anforderungen der Gerätevorschriften. Dies gilt insbesondere für die Festlegung der Bemessungsspannung und der damit zusammenhängenden Luft- und Kriechstrecken.
- Alle Angaben der Bemessungsdaten der in diesem Katalog aufgeführten Steckverbindern sind auf die Überspannungskategorie III sowie den Verschmutzungsgrad 3 (Anwendung im Maschinenbau) bezogen.
- Alle technischen Angaben beziehen sich auf Steckverbinder, also Betriebsmittel, die bei bestimmungsgemäßer Verwendung (unter elektrischer Spannung) nicht gesteckt oder getrennt werden dürfen. Soweit Steckverbinder im Sinne von Steckvorrichtungen (Steckverbinder mit Schaltleistung) verwendet werden, ist dies in der Kurzinformation der betreffenden Abschnitte aufgeführt.
- Der Berührungsschutz der Kontakteinsätze im Anschlussbereich ist durch den Einbau sicherzustellen.
- Beim Einbau der Steckverbinder in nicht leitende Gehäuse sind beide Schutzleiter (Ausführung 2x PE) anzuschließen.
- Ein ausführliches Kompendium von Steckverbinder-Begriffen befindet sich am Ende dieses Kapitels.
- Nachstehend aufgeführte Auszüge aus Normen dienen der allgemeinen Information. Im konkreten Anwendungsfall sind die jeweils gültigen Normen anzuwenden.
- Prüfverfahren nach IEC 60512 entsprechen den Prüfverfahren nach DIN EN 60512 oder DIN IEC 60512. Die DIN IEC 60664-1 entspricht DIN VDE 0110-1

Anschlussstechniken

• Schraubverbindung

Schraubklemmen werden nach EN 60999-1/VDE 0609 bemessen. Die Gewindegröße in Abhängigkeit vom Leiterquerschnitt sowie das dazugehörige Anzugs- und Prüfdrehmoment können untenstehender Tabelle 1 entnommen werden.

Tabelle 1

Leiterquerschnitt (mm ²)	1	1,5	2,5	4	6	10
Schraubengewinde	M 2,6	M 3	M 3	M 3,5	M 4	M 4
Prüfdrehmoment (Ncm)	40	50	50	80	120	120

Die Ausziehkräfte (Streubereich) der Leiter aus einer Schraubverbindung eines Kontaktelementes zeigt das untenstehende Diagramm 1 für eine Klemmschraube M 3, angezogen mit einem Drehmoment von 50 Ncm.

Diagramm 1

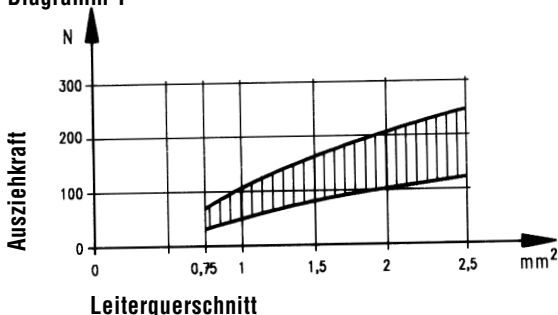

! General technical information

Remarks:

- The Safety of connectors/connectors with braking capacity (CBC) depends on the right selection of products, the correct installation and a proper assembly.
- Decisions for the application of connectors are the requirements of the equipment specifications. This is especially the case for the definition of the rated voltage and the related clearances and creepage distances.
- All rated data for the connectors listed in this catalogue is based on overvoltage category III and pollution degree 3 (machine tool application).
- All technical data is specified for connectors, which are not under load when mated or disconnected. If in special cases connectors can be used in the sense of plug and socket devices (connector with breaking capacity), this is mentioned in the brief information of the particular section.
- Correct mounting will protect against electrical shock when mating the connectors.
- If connectors are mounted in non conductive housings both protective earthing terminals shall be mounted.
- A detailed connector glossary can be found at the end of this catalogue.
- All mentioned excerpts of standards are for general information only. For specific cases the valid original standards have to be consulted.
- Test methods acc. IEC 60512 comply with test methods acc. DIN EN 60512 or DIN IEC 60512. IEC 60664-1 complies with DIN VDE 0110-1

Termination methods

• Screw connection

Screw clamps are designed acc. to EN 60999-1/VDE 0609. Chart 1 below shows the screw size depending on wire size and the required clamping and testing torque.

Chart 1

Wire size (mm ²)	1	1,5	2,5	4	6	10
Screw size	M 2,6	M 3	M 3	M 3,5	M 4	M 4
Test torque (Ncm)	40	50	50	80	120	120

Diagram 1 below shows the range of tensile strength for a screw connection with a clamp screw M 3, fastened with a torque of 50 Ncm, depending on the wire size.

Diagram 1

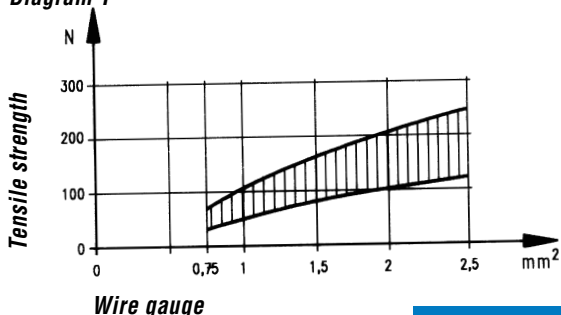

• Crimpverbindung

Eine Crimpverbindung ist eine nicht lösbare elektrische Verbindung zwischen einem Leiter und einem Crimpkontakt mit Hilfe der Crimptechnik. Durch genau auf Crimphülse und Leiterquerschnitt abgestimmte Crimpprofile werden durch Druck und gezielte Verformung zuverlässige elektrische Verbindungen hergestellt. Es gibt offene Crimphülsen (gestanzte Kontakte) und geschlossene Crimphülsen (gedrehte Kontakte).

Die wesentlichen Vorteile von Crimpverbindungen sind:

- Rationelle Verarbeitung der Kontakte
- Konstante elektrische und mechanische Werte durch gleichbleibende Crimpqualität.

(Eine ausführliche Beschreibung der Crimptechnologie finden Sie in unserem Katalog „Werkzeuge“.)

Die Anforderungen an Crimpverbindungen sind in der DIN EN 60352-2, festgelegt.

Ein wesentliches Merkmal für die Qualität einer Crimpverbindung ist die erreichte Zugfestigkeit des Anschlusses. Sie kann mit einfachen Mitteln zur Überwachung der Qualität herangezogen werden. Aus untenstehender Tabelle 2 kann die Mindest-Zugfestigkeit entnommen werden.

Tabelle 2

Zugfestigkeit von Crimpverbindungen

Leiterquerschnitt		Zugfestigkeit
mm ²	AWG ¹⁾	N
0,05	30	6
0,08	28	11
0,12	26	15
0,14		18
0,22	24	28
0,25		32
0,32	22	40
0,5	20	60
0,75		85
0,82	18	90
1,0		108
1,3	16	135
1,5		150
2,1	14	200
2,5		230
3,3	12	275
4,0		310
5,3	10	355
6,0		360
8,4	8	370
10,0		380

¹⁾Nur zur Information

• Crimp connection

A crimp connection is a non-detachable electrical connection between a wire and a crimp contact produced with the crimp technology. Precise crimping dies are matched to the crimp barrel and the wire size and a defined deformation results in a reliable electrical connection. There are open barrels (stamped contacts) and closed crimp barrels (turned contacts).

The main advantages of crimp connections are:

- Efficient termination of contacts.
- Reproducible electrical and mechanical figures by a constant crimp quality.

(A detailed description of the crimp technology can be found in our catalogue „tools“.)

The requirements for crimp connections are defined in DIN EN 60352-2.

An important point for the quality of a crimp connection is the achieved tensile strength of the termination. Measuring the tensile strength is a practicable means for quality control purposes. Chart 2 below shows the required minimum tensile strength for open and closed barrels according to the wire size.

Chart 2

Tensile strength for crimp connections

Wire size		Tensile strength
mm ²	AWG ¹⁾	N
0,05	30	6
0,08	28	11
0,12	26	15
0,14		18
0,22	24	28
0,25		32
0,32	22	40
0,5	20	60
0,75		85
0,82	18	90
1,0		108
1,3	16	135
1,5		150
2,1	14	200
2,5		230
3,3	12	275
4,0		310
5,3	10	355
6,0		360
8,4	8	370
10,0		380

¹⁾only for information

Da in verschiedenen Bereichen der Industrie auch mit Leitern nach der amerikanischen Drahtlehre AWG (American Wire Gauge) gearbeitet wird, folgt hiernach Tabelle 3 zur Umrechnung von AWG in mm².

Tabelle 3

AWG	Leiteraufbau	Leiter-Ø	Leiterquerschnitt
30	1 x 0,25 7 x 0,10	0,25 mm 0,36 mm	0,05 mm ² 0,06 mm ²
28	1 x 0,32 7 x 0,13	0,32 mm 0,38 mm	0,08 mm ² 0,09 mm ²
26	1 x 0,40 7 x 0,16 19 x 0,10	0,40 mm 0,48 mm 0,51 mm	0,13 mm ² 0,14 mm ² 0,15 mm ²
24	1 x 0,51 7 x 0,20 19 x 0,13	0,51 mm 0,61 mm 0,64 mm	0,21 mm ² 0,23 mm ² 0,24 mm ²
22	1 x 0,64 7 x 0,25 19 x 0,16	0,64 mm 0,76 mm 0,81 mm	0,33 mm ² 0,36 mm ² 0,38 mm ²
20	1 x 0,81 7 x 0,32 19 x 0,20	0,81 mm 0,97 mm 1,02 mm	0,52 mm ² 0,56 mm ² 0,62 mm ²
18	1 x 1,02 19 x 0,25	1,02 mm 1,27 mm	0,79 mm ² 0,96 mm ²
16	19 x 0,29	1,44 mm	1,23 mm ²
14	19 x 0,36	1,80 mm	1,95 mm ²
12	19 x 0,46	2,29 mm	3,09 mm ²
10	37 x 0,40	3,10 mm	4,60 mm ²
8	133 x 0,29	4,0 mm	8,80 mm ²
6	133 x 0,36	5,5 mm	13,5 mm ²

Zu beachten ist, dass Leiter mit gleicher AWG-Nummer, aber unterschiedlichem Aufbau, leicht unterschiedliche Querschnitte aufweisen!

Tabelle 4

Aufbau und Abmessungen von Kupferleitungen

Leiterquerschnitt	Leiteraufbau	Leiter-Ø
0,09 mm ²	12 x 0,10	0,48 mm
0,14 mm ²	18 x 0,10	0,50 mm
0,25 mm ²	14 x 0,15	0,70 mm
0,34 mm ²	7 x 0,25	0,78 mm
0,5 mm ²	16 x 0,20	1,0 mm
0,75 mm ²	24 x 0,20	1,2 mm
1,0 mm ²	32 x 0,20	1,4 mm
1,5 mm ²	30 x 0,25	1,6 mm
2,5 mm ²	35 x 0,30	2,2 mm
4,0 mm ²	56 x 0,30	2,8 mm
6,0 mm ²	19 x 0,64	3,4 mm
10 mm ²	19 x 0,80	4,3 mm

The chart below allows a cross reference between American Wire Gauge (AWG) and metric wire sizes (mm²).

Chart 3

AWG	Wire composition	Wire diameter	Wire size
30	1 x 0,25 7 x 0,10	0,25 mm 0,36 mm	0,05 mm ² 0,06 mm ²
28	1 x 0,32 7 x 0,13	0,32 mm 0,38 mm	0,08 mm ² 0,09 mm ²
26	1 x 0,40 7 x 0,16 19 x 0,10	0,40 mm 0,48 mm 0,51 mm	0,13 mm ² 0,14 mm ² 0,15 mm ²
24	1 x 0,51 7 x 0,20 19 x 0,13	0,51 mm 0,61 mm 0,64 mm	0,21 mm ² 0,23 mm ² 0,24 mm ²
22	1 x 0,64 7 x 0,25 19 x 0,16	0,64 mm 0,76 mm 0,81 mm	0,33 mm ² 0,36 mm ² 0,38 mm ²
20	1 x 0,81 7 x 0,32 19 x 0,20	0,81 mm 0,97 mm 1,02 mm	0,52 mm ² 0,56 mm ² 0,62 mm ²
18	1 x 1,02 19 x 0,25	1,02 mm 1,27 mm	0,79 mm ² 0,96 mm ²
16	19 x 0,29	1,44 mm	1,23 mm ²
14	19 x 0,36	1,80 mm	1,95 mm ²
12	19 x 0,46	2,29 mm	3,09 mm ²
10	37 x 0,40	3,10 mm	4,60 mm ²
8	133 x 0,29	4,0 mm	8,80 mm ²
6	133 x 0,36	5,5 mm	13,5 mm ²

It has to be noted that wires of the same AWG number but with different composition have slightly different mm².

Chart 4

Composition and Dimensions of Copper Wires

Wire Size	Wire Composition	Wire diameter
0,09 mm ²	12 x 0,10	0,48 mm
0,14 mm ²	18 x 0,10	0,50 mm
0,25 mm ²	14 x 0,15	0,70 mm
0,34 mm ²	7 x 0,25	0,78 mm
0,5 mm ²	16 x 0,20	1,0 mm
0,75 mm ²	24 x 0,20	1,2 mm
1,0 mm ²	32 x 0,20	1,4 mm
1,5 mm ²	30 x 0,25	1,6 mm
2,5 mm ²	35 x 0,30	2,2 mm
4,0 mm ²	56 x 0,30	2,8 mm
6,0 mm ²	19 x 0,64	3,4 mm
10 mm ²	19 x 0,80	4,3 mm

Strombelastbarkeit

Die Strombelastbarkeit eines Steckverbinders wird mit einer Derating-Kurve dargestellt. Aus ihr kann abgelesen werden, welche Ströme dauernd und gleichzeitig über alle Kontakte fließen dürfen. Die Kurve wird durch Prüfung ermittelt. Als Basis dient dazu die Norm DIN EN 60512. Die obere Grenztemperatur wird durch die verwendeten Kontakt- und Isolierwerkstoffe bestimmt. Die Summe aus der Umgebungstemperatur und der durch die Strombelastung hervorgerufenen Übertemperatur darf die obere Grenztemperatur des Steckverbinders nicht übersteigen. Somit ist die Strombelastbarkeit kein konstanter Wert, sondern sinkt mit steigender Umgebungstemperatur. Als allgemeines Beispiel sei gesagt, dass bei einem vorgegebenen Steckverbinder, der bei einer Umgebungstemperatur von 40°C mit einem Dauerstrom von 16A auf allen Kontakten belastet werden darf, dieser Wert bei einer Umgebungstemperatur von 80°C auf z.B. 12A sinken kann. Auf der anderen Seite ist es in der Praxis sehr oft der Fall, dass nicht alle Anschlüsse gleichzeitig mit dem maximal zulässigen Strom belastet werden, so dass dann einzelne Kontakte mit einem höheren Strom als nach der Derating-Kurve zulässig, beaufschlagt werden können. Diese Grenzwerte sind durch Prüfung zu ermitteln.

Diagramm 3





Tabelle 5

Strombelastbarkeit von Kupferleitern in (A)

Installationsart Installation type	Querschnitt (mm ²) Wire size (mm ²)	0,25	0,34	0,5	0,75	1	1,5	2,5	4	6	10
 B1 Leiter in Schutzrohren und Installationskanälen Wires in conduits and installation channels		-	-	-	7,6	10,4	13,5	18,3	25	32	44
 B2 Kabel und Leitungen in Schutzrohren oder Installationskanälen Cables and conductors in conduits or installation channels		-	-	-	-	9,6	12	16,5	23	29	40
 C Kabel und Leitungen an Wänden Cables and conductors along walls		4,0	5,0	7,1	9,1	11,7	15,2	21	28	36	50
 E Kabel und Leitungen auf Kabelpritschen Cables and conductors on plank		4,0	5,0	7,1	9,1	11,5	16,1	22	30	37	52

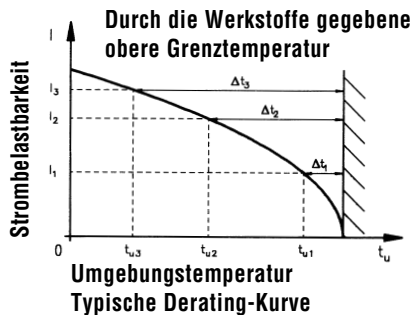
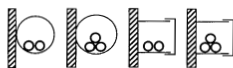
Darstellung in Anlehnung an DIN EN 60204 für PVC-isolierte Kupferleiter in einer Umgebungstemperatur von +40°C unter Dauerbetriebsbedingungen. Für abweichende Bedingungen wie andere Temperaturen, Installationen, Isoliermaterialien oder Leitern sind entsprechende Korrekturfaktoren zu verwenden (siehe nächste Seite).

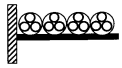
Current carrying capacity

The current carrying capacity of a connector is shown by a derating curve. The curve shows the currents that the connector can carry continuously and simultaneously through all its contacts. The curve is determined by testing following the standard DIN EN 60512. The upper temperature is limited by the contact and insulation material used. The sum of the ambient temperature and the temperature created by the current flow may not exceed the upper temperature. This means that the current carrying capacity has no fixed value but decreases with increasing ambient temperatures.

As a general example it can be said that a given connector which can carry 16A through all its contacts at 40°C ambient temperature can carry less, e.g. 12A, at an ambient temperature of 80°C.

On the other hand it is often the case that not all contacts carry the whole rated current, which means that some single contacts may carry a higher current than that according to the derating curve. These currents have to be defined by testing.

Diagram 3

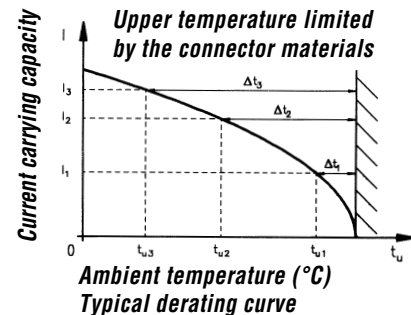

Chart 5

Current carrying capacity of copper wires in (A)

Description according to DIN EN 60204 for PVC insulated copper wires with a working temperature of +40C. For other requirements, such as for other temperatures, mountings, or wires corresponding correction factors are used (see next page).

Reduktionsfaktoren

Die Werte in der Tabelle 5 beziehen sich auf eine Umgebungstemperatur von 40°C. Für andere Umgebungstemperaturen muss der Wert mit den Faktoren aus der folgenden Tabelle 6 korrigiert werden.

Tabelle 6

Umgebungstemperatur (°C)	Korrekturfaktor
30	1,15
35	1,03
40	1,00
45	0,91
50	0,82
55	0,71
60	0,58

Für Installationen mit vielen belasteten Kabeln und Leitungen/Paaren verringern sich die Werte der Strombelastbarkeit entsprechend den nachfolgenden Tabellen 7 und 8.

Tabelle 7

Reduktionsfaktoren für Leitungshäufung

Art der Installation <i>Installation type</i>	Anzahl der belasteten Kabel und Leitungen / Paare <i>Number of cables and conductors / pairs under load</i>			
	2	4	6	9
Drehstromkabel und -leitung <i>Threephase cable and conductor</i>				
B1 und/and B2	0,80	0,85	0,87	0,86
C	0,65	0,75	0,78	0,76
E-einlagig / <i>one row</i>	0,57	0,72	0,75	0,72
E-mehrlagig / <i>multi row</i>	0,50	0,70	0,73	0,88
Gleichstromleitung (Paar), unabhängig von der Installationsart <i>DC conductor (pair), independent of installation type</i>	1,0	0,76	0,64	0,43

Tabelle 8

Reduktionsfaktoren für Mehraderkabel (-leitungen) bis zu 10 mm²

Anzahl der belasteten Leitungen (Paare) <i>Number of conductors (pairs) under load</i>	Wechselstrom (Leiter >1 mm ²) <i>AC (conductor > 1 mm²)</i>	Gleichstrom (Paare 0,2 bis 0,75 mm ²) <i>DC (Pairs 0,2 to 0,75 mm²)</i>
5	0,75	0,52
7	0,65	0,45
10	0,55	0,39
24	0,40	0,27

Leiter von Steuerkreisen benötigen normalerweise keine Herabsetzung.

Reduction values

The values in chart 5 are based on an ambient temperature of 40 °C. For other ambient temperatures the values have to be adjusted using the correction values of chart 6 below.

Chart 6

Ambient temperature (°C)	Correction value
30	1,15
35	1,03
40	1,00
45	0,91
50	0,82
55	0,71
60	0,58

For installations with many cables and conductors under load the current carrying capacity is reduced according to the two following charts 7 and 8.

Chart 7

Reduction values for accumulated conductors

Chart 8

Reduction values for multicore cable and conductors up to 10mm²

Conductors of control circuits generally do not need a reduction.

Stoßstrombelastbarkeit

Eine besondere Belastung kann sich für Steckverbinder und deren Kontakte durch einen Stoßstrom ergeben, der z.B. durch einen Kurzschluss in der Anlage oder durch Schaltvorgänge entstehen kann. Die kurzzeitig sehr hohe Stromerwärmung kann nach außen nicht schnell genug abgeführt werden, so dass es zu einer örtlich sehr starken Erwärmung der Kontakte kommt, die z.B. in extremen Fällen zu einer Verschweißung führen kann.

Durch unsere robuste Kontaktkonstruktion sind die hier beschriebenen Steckverbinder gegenüber Stoßströmen relativ unempfindlich. Richtwerte können dem nachfolgenden Diagramm 4 entnommen werden.

Diagramm 4

Stoßstrombelastbarkeit von Einzelkontakten

Impulse current carrying capacity

A surge can happen to a connector and its contacts by an impulse current, e.g. through a short circuit in the system or by switching operations. The short-timed high current heat cannot be transferred outside fast enough so the contacts are stressed by the high temperature which in the worst case can lead to a local weld. The robust design of our connectors prevents most damage by impulse currents.

The diagram 4 below can be used as a guideline.

Diagramm 4

Impulse current carrying capacity of single contacts

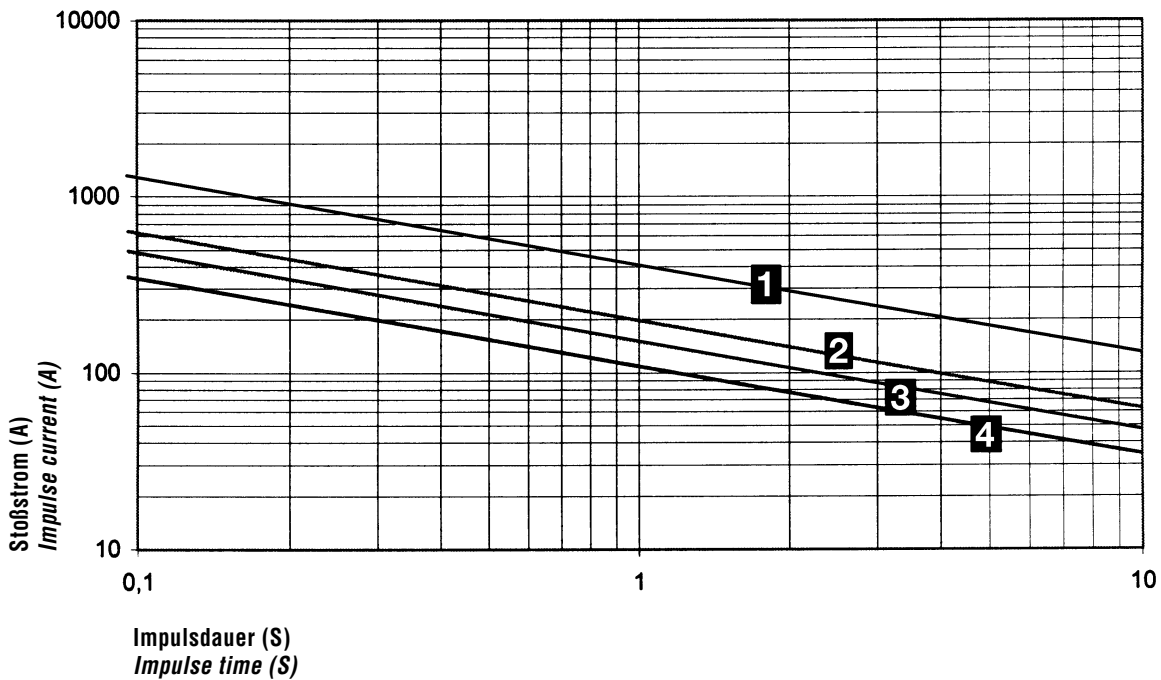

Kurve Nr.	Steckverbinder-Bauform	Curve No.	Connector style
1	C146 E oder A mit Schraubkontakt	1	C146 E or A with screw contact
2	C146 E mit gestanztem Crimpkontakt	2	C146 E with stamped crimp contact
3	C146 S mit gestanztem Crimpkontakt	3	C146 S with stamped crimp contact
4	C146 D mit gestanztem Crimpkontakt	4	C146 D with stamped crimp contact

Spannungseinstufung der Steckverbinder**Allgemeines**

Zur Spannungseinstufung von Steckverbindern werden die Luft- und Kriechstrecken herangezogen. Die Beurteilung und Bemessung der Luft- und Kriechstrecken hat sich durch die Einführung der Isolationskoordination geändert.

Es gelten dafür die folgenden Normen:

IEC 60664-1/10.92
Insulation coordination for equipment within low-voltage systems

DIN VDE 0110-1/4.97
Isolationskoordination für elektrische Betriebsmittel in Niederspannungsanlagen

Isolationskoordination umfasst die Auswahl der elektrischen Isolationseigenschaften eines Betriebsmittels hinsichtlich dessen Anwendung und in Bezug auf seine Umgebung.

Luftstrecken

Die Luftstrecke ist die kürzeste Entfernung in Luft zwischen zwei leitenden Teilen. Ein wichtiger Punkt bei der Bemessung von Luftstrecken ist zunächst die Festlegung der Überspannungskategorie. Die Norm hat die möglichen Überspannungen in die nachstehenden vier Kategorien eingeteilt:

Überspannungskategorie I
Betriebsmittel, die zur Anwendung in Geräten oder Teilen von Anlagen bestimmt sind, in denen keine Überspannungen auftreten können. Hierunter fallen Geräte, die vorwiegend mit Kleinspannungen betrieben werden.

Überspannungskategorie II
Betriebsmittel, die zur Anwendung in Anlagen oder Teilen von diesen bestimmt sind, in denen Blitzüberspannungen nicht berücksichtigt werden müssen, aber wohl Überspannungen durch Schaltvorgänge. Hierunter fallen z.B. elektrische Haushaltsgeräte.

Überspannungskategorie III
Betriebsmittel, die zur Anwendung in Anlagen oder Teilen von diesen bestimmt sind, bei denen Blitzüberspannungen nicht berücksichtigt werden müssen, wohl aber Überspannungen durch Schaltvorgänge und an die im Hinblick auf die Sicherheit und Verfügbarkeit des Betriebsmittels oder von davon abhängigen Netzen besondere Anforderungen gestellt werden. Hierunter fallen Betriebsmittel für feste Installationen, z.B. Schutzeinrichtungen, Schütze, Schalter und Steckdosen.

Überspannungskategorie IV
Betriebsmittel, die zur Anwendung in Anlagen oder Teilen von diesen bestimmt sind, bei denen Blitzüberspannungen zu berücksichtigen sind. Hierunter fallen Betriebsmittel zum Anschluss an Freileitungen, z.B. Rundsteuerempfänger, Zähler.

Voltage grading of connectors**General**

Clearances and creepage distances are the base for voltage grading of connectors. Valuation and dimensioning of clearances and creepage distances have changed since the introduction of insulation coordination.

The following standards apply for this:

*IEC 60664-1/10.92
Insulation coordination for equipment within low-voltage systems*

*DIN VDE 0110-1/4.97
Isolationskoordination für elektrische Betriebsmittel in Niederspannungsanlagen*

Insulation coordination comprises the selection of the electrical insulation performances of the equipment, taking into account the expected use and its environment.

Clearances

The clearance is the shortest distance in air between two conductive parts. An important point for the dimensioning of clearances is the determination of the overvoltage category. The above standard specifies the possible overvoltages into the four following categories:

*Overvoltage category I
Equipment intended for the use in appliances or parts of installations in which no overvoltage can occur.
Examples are low-voltage equipments.*

*Overvoltage category II
Equipment intended for the use in installations or parts of it in which lightning overvoltages do not need to be considered, but switching overvoltages generated by the equipment do need to be considered.
Examples are household appliances.*

*Overvoltage category III
Equipment intended for the use in installations or parts of it in which lightning overvoltages do not need to be considered, however switching overvoltages generated by the equipment, and for cases where the reliability and the availability of the equipment or its dependent circuits are subject to special requirements.
Examples are protecting means, switches and sockets.*

*Overvoltage category IV
Equipment intended for the use in installations or parts of it in which lightning overvoltage has to be considered.
Examples are electricity meters, overcurrent protection switches.*

Liegt die Überspannungskategorie fest, dann kann je nach Nennspannungsbereich des Stromversorgungs-Systems und der Überspannungskategorie die Bemessungs-Stoßspannung für das Betriebsmittel ermittelt werden. Es gilt dabei die folgende Tabelle 9:

Once the overvoltage category has been defined the rated impulse withstand voltage can be selected for the equipment based on the nominal voltage of the supply system and the overvoltage category using chart 9 below:

Tabelle 9

Chart 9

Nennspannung des Stromversorgungs-Systems in V (nach IEC 60038) Nominal voltage of the supply system in V (based on IEC 60038)	Bemessungs-Stoßspannung in kV für Überspannungskategorie Rated impulse voltage in kV for overvoltage category			
Drei-phasige Systeme / Three phase systems	IV	III	II	I
230/400 277/480	6	4	2,5	1,5
400/690	8	6	4	2,5
1000	12	8	6	4

Ist die Bemessungs-Stoßspannung ermittelt, so muss jetzt der Verschmutzungsgrad entsprechend der zu erwartenden Verschmutzung der unmittelbaren Umgebung des Betriebsmittels festgelegt werden. Hierzu dienen die folgenden vier festgelegten Grade:

*After the rated impulse withstand voltage has been selected the pollution degree must be defined taking the expected pollution around the equipment into account.
The following four degrees of pollution are established:*

Verschmutzungsgrad 1

Es tritt keine oder nur trockene, nicht leitfähige Verschmutzung auf. Die Verschmutzung hat keinen Einfluss.

Pollution degree 1

No pollution or only dry, non-conductive pollution occurs. The pollution has no influence.

Verschmutzungsgrad 2

Es tritt nur nicht leitfähige Verschmutzung auf. Gelegentlich muss jedoch mit vorübergehender Leitfähigkeit durch Betauung gerechnet werden.

Pollution degree 2

Only non-conductive pollution occurs except occasionally a temporary conductivity caused by condensation is to be expected.

Verschmutzungsgrad 3

Es tritt leitfähige Verschmutzung auf oder trockene, nicht leitfähige Verschmutzung, die leitfähig wird, da Betauung zu erwarten ist.

Pollution degree 3

Conductive pollution occurs or dry non-conductive pollution occurs which becomes conductive due to condensation which is to be expected.

Verschmutzungsgrad 4

Die Verunreinigung führt zu einer beständigen Leitfähigkeit, hervorgerufen durch leitfähigen Staub, Regen oder Schnee.

Pollution degree 4

The pollution generates persistent conductivity caused by conductive dust or by rain or snow.

Zu beachten ist, dass Teile von Steckverbindern und Steckvorrichtungen mit ausreichender Kapselung (min. IP 54) auch nach einem niedrigeren Verschmutzungsgrad bemessen werden können. Dies gilt auch für Steckverbinder im Trennbereich, bei denen die Kapselung im gesteckten Zustand durch das Steckverbindergehäuse erreicht wird und die nur für Prüf- und Wartungszwecke getrennt werden.

It has to be noted that for a connector or plug and socket device with a degree of protection of min. IP 54 the parts inside the enclosure may be dimensioned for a lower pollution degree. This also applies to mated connectors which enclosure is ensured through the connector housing and which may only be disengaged for test and maintenance purposes.

Aus der Bemessungs-Stoßspannung und dem Verschmutzungsgrad können jetzt aus Tabelle 10 die Mindest-Luftstrecken ermittelt werden.

When impulse withstand voltage and the pollution degree are defined the minimum clearances can be selected from chart 10.

Tabelle 10

Chart 10

Bemessungs- Stoßspannung in kV <i>Impulse withstand voltage in kV</i>	Mindestluftstrecken in mm bis zu 2000 m über NN <i>Minimum clearances in air in mm up to 2000 m above sea level</i>							
	Fall A (inhomogenes Feld) <i>Case A (non homogeneous field)</i>				Fall B (homogenes Feld) <i>Case B (homogeneous field)</i>			
	Verschmutzungsgrad <i>Pollution degree</i>				Verschmutzungsgrad <i>Pollution degree</i>			
	1	2	3	4	1	2	3	4
0,33	0,01	0,2	0,8	1,6	0,01	0,2	0,8	1,6
0,40	0,02				0,02			
0,50	0,04				0,04			
0,60	0,06	0,25	1,0	2	0,06	0,3	1,2	2
0,80	0,10				0,1			
1,0	0,15				0,15			
1,2	0,25	1,0	1,5	3	0,2	0,45	1,5	3
1,5	0,5				0,3			
2,0	1,0				0,45			
2,5	1,5	1,5	2	3	0,6	0,6	1,2	2
3,0	2				0,8			
4,0	3				1,2			
5,0	4	4	4	4	1,5	1,5	1,5	3
6,0	5,5				2			
8,0	8				3			
10	11	11	11	11	3,5	3,5	3,5	3,5
12	14				4,5			
15	18				5,5			
20	25	25	25	25	8	8	8	8
25	33				10			
30	40				12,5			
40	60	60	60	60	17	17	17	17
50	75				22			
60	90				27			
80	130	130	130	130	35	35	35	35
100	170				45			

Bei der Festlegung der Mindestluftstrecken von Steckverbindern sind in der Regel die Werte des inhomogenen Falls anzuwenden bzw. ist die entsprechende Luftstrecke durch eine Spannungsprüfung zu überprüfen.

When defining the minimum clearances for connectors generally the values of the inhomogeneous field can be chosen or the required clearance has to be defined by a voltage test.

Kriechstrecken

Die Kriechstrecke ist die kürzeste Entfernung entlang der Oberfläche eines Isolierstoffes zwischen zwei leitenden Teilen.
Zur Bemessung der Kriechstrecke wird die aus der entsprechenden Netzart abgeleitete Bemessungsspannung und die bereits bei der Luftstrecke gewählte Zuordnung des Verschmutzungsgrades herangezogen. Außerdem wird die Kriechwegbildung des vom Hersteller verwendeten Isolierstoffes berücksichtigt. Die Isolierstoffe werden entsprechend ihrem Kriechwegbildungsfaktor CTI (Comparative Tracking Index) in vier Gruppen eingeteilt:

- Isolierstoffgruppe I 600 ≤ CTI
- Isolierstoffgruppe II 400 ≤ CTI < 600
- Isolierstoffgruppe IIIa 175 ≤ CTI < 400
- Isolierstoffgruppe IIIb 100 ≤ CTI < 175

Creepage distances

The creepage distance is the shortest distance along the surface of the insulating material between two conductive parts.
For the dimensioning of the creepage distance the following factors are taken into account: the rated voltage, the pollution degree and the tracking formation of the insulating material. The materials are separated into four groups according to their CTI values (Comparative Tracking Index):

- Material group I 600 ≤ CTI
- Material group II 400 ≤ CTI < 600
- Material group IIIa 175 ≤ CTI < 400
- Material group IIIb 100 ≤ CTI < 175

Die Mindestkriechstrecken können dann aus der Tabelle 11 entnommen werden.

The minimum creepage distances can be selected from chart 11.

Tabelle 11

Chart 11

Bemes- sungs- spannung U-eff Rated voltage U in V	Mindestkriechstrecke in mm / Min. creepage distance in mm														
	Gedruckte Schaltungen Printed circuits			Übrige Betriebsmittel / Other devices											
	Verschmutzungs- grad Pollution degree			Verschmutzungsgrad Pollution degree				Verschmutzungsgrad Pollution degree				Verschmutzungsgrad Pollution degree			
				1	2			3			4				
	1	2	Isolierstoffgruppe Material group					Isolierstoffgruppe Material group				Isolierstoffgruppe Material group			
2)	3)	2)	I	II	III a	III b	I	II	III a	III b	I	II	III a	III b	
10	0,025	0,04	0,08	0,4	0,4	0,4		1	1	1		1,6	1,6	1,6	
12,5	0,025	0,04	0,09	0,42	0,42	0,42		1,05	1,05	1,05		1,6	1,6	1,6	
16	0,025	0,04	0,1	0,45	0,45	0,45		1,1	1,1	1,1		1,6	1,6	1,6	
20	0,025	0,04	0,11	0,48	0,48	0,48		1,2	1,2	1,2		1,6	1,6	1,6	
25	0,025	0,04	0,125	0,5	0,5	0,5		1,25	1,25	1,25		1,7	1,7	1,7	
32	0,025	0,04	0,14	0,53	0,53	0,53		1,3	1,3	1,3		1,8	1,8	1,8	
40	0,025	0,04	0,16	0,56	0,8	1,1		1,4	1,6	1,8		1,9	2,4	3	
50	0,025	0,04	0,18	0,6	0,85	1,2		1,5	1,7	1,9		2	2,5	3,2	
63	0,04	0,063	0,2	0,63	0,9	1,25		1,6	1,8	2		2,1	2,6	3,4	
80	0,063	0,1	0,22	0,67	0,95	1,3		1,7	1,9	2,1		2,2	2,8	3,6	
100	0,1	0,16	0,25	0,71	1	1,4		1,8	2	2,2		2,4	3,0	3,8	
125	0,16	0,25	0,28	0,75	1,05	1,5		1,9	2,1	2,4		2,5	3,2	4	
160	0,25	0,4	0,32	0,8	1,1	1,6		2	2,2	2,5		3,2	4	5	
200	0,4	0,63	0,42	1	1,4	2		2,5	2,8	3,2		4	5	6,3	
250	0,56	1	0,56	1,25	1,8	2,5		3,2	3,6	4		5	6,3	8	
320	0,75	1,6	0,75	1,6	2,2	3,2		4	4,5	5		6,3	8	10	
400	1	2	1	2	2,8	4		5	5,6	6,3		8	10	12,5	
500	1,3	2,5	1,3	2,5	3,6	5		6,3	7,1	8,0		10	12,5	16	
630	1,8	3,2	1,8	3,2	4,5	6,3		8	9	10		12,5	16	20	
800	2,4	4	2,4	4	5,6	8		10	11	12,5		16	20	25	
1000	3,2	5	3,2	5	7,1	10		12,5	14	16		20	25	32	
1250			4,2	6,3	9	12,5		16	18	20		25	32	40	
1600			5,6	8	11	16		20	22	25		32	40	50	
2000			7,5	10	14	20		25	28	32		40	50	63	
2500			10	12,5	18	25		32	36	40		50	63	80	
3200			12,5	16	22	32		40	45	50		63	80	100	
4000			16	20	28	40		50	56	63		80	100	125	
5000			20	25	36	50		63	71	80		100	125	160	
6300			25	32	45	63		80	90	100		125	160	200	
8000			32	40	56	80		100	110	125		160	200	250	
10000			40	50	71	100		125	140	160		200	250	320	

Die in diesem Katalog beschriebenen Steckverbinder sind festen Bemessungsspannungen zugeordnet, die sich auf den allgemeinen Anwendungsfall im Maschinenbau beziehen. Liegen davon abweichende Anwendungsfälle vor, so kann aufgrund der obigen Tabelle eine andere Bemessungsspannung ermittelt werden.

Connectors in this catalogue are allocated to fixed rated voltages which apply to the machine building industry. In case of other applications the above chart can be used to determine other rated voltages.

Schutzarten

Elektrische Betriebsmittel, zu denen Steckverbinder zählen, müssen aus Sicherheitsgründen gegen Einflüsse von außen, wie z.B. Staub, Fremdkörper, Berührung, Feuchtigkeit und Wasser geschützt werden. Diesen Schutz übernehmen bei Industrie-Steckverbindern die Gehäuse mit ihrer Verriegelung und dem abgedichteten Kabeleinlass.

Den Grad der Schutzart kann man dem Einsatz entsprechend wählen. In der Norm IEC 60529 bzw. DIN EN 60529 sind die Schutzgrade festgelegt und in verschiedene Klassen eingeteilt.

Die Bezeichnung erfolgt in nachstehender Weise:

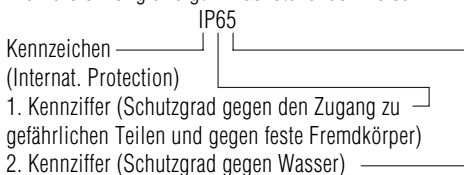

Die nachfolgenden Tabellen 12 und 13 zeigen alle Schutzarten in einer Übersicht.

Tabelle 12

1. Kennziffer	Kurzbeschreibung	Definition
0	Nicht geschützt	–
1	Geschützt gegen den Zugang zu gefährlichen Teilen mit dem Handrücken. Geschützt gegen feste Fremdkörper $\varnothing \geq 50$ mm.	Die Sonde, Kugel $\varnothing 50$ mm, darf nicht voll eindringen und muss ausreichenden Abstand zu gefährlichen Teilen haben.
2	Geschützt gegen den Zugang zu gefährlichen Teilen mit einem Finger. Geschützt gegen feste Fremdkörper $\varnothing \geq 12,5$ mm.	Der gegliederte Prüffinger, $\varnothing 12$ mm, 80 mm Länge, muss ausreichenden Abstand zu gefährlichen Teilen haben. Die Sonde, $\varnothing 12,5$ mm, darf nicht voll eindringen.
3	Geschützt gegen den Zugang zu gefährlichen Teilen mit einem Werkzeug. Geschützt gegen feste Fremdkörper $\varnothing \geq 2,5$ mm.	Die Sonde, $\varnothing 2,5$ mm, darf überhaupt nicht eindringen.
4	Geschützt gegen den Zugang zu gefährlichen Teilen mit einem Draht. Geschützt gegen feste Fremdkörper $\varnothing \geq 1$ mm.	Die Sonde, $\varnothing 1$ mm, darf überhaupt nicht eindringen.
5	Geschützt gegen den Zugang zu gefährlichen Teilen mit einem Draht. Staubgeschützt.	Die Sonde, $\varnothing 1$ mm, darf nicht eindringen. Eindringen von Staub ist nicht vollständig verhindert, aber der Staub darf nicht in einer solchen Menge eindringen, dass das zufriedenstellende Arbeiten des Gerätes oder die Sicherheit beeinträchtigt wird.
6	Geschützt gegen den Zugang zu gefährlichen Teilen mit einem Draht. Staubsicht.	Die Sonde, $\varnothing 1$ mm, darf nicht eindringen. Kein Eindringen von Staub.

Degree of protection

Electrical connector devices have to be protected for safety reasons from outside influences like dust, foreign objects, direct contact, moisture and water. This protection is provided on industrial connectors by the housing latching devices and sealed cable entries. The degree of protection depends on the type of intended use. The standard IEC 60529 and/or DIN EN 60529 has specified the degree of protection and divided them into several classes.

The degree of protection is indicated in the following way:

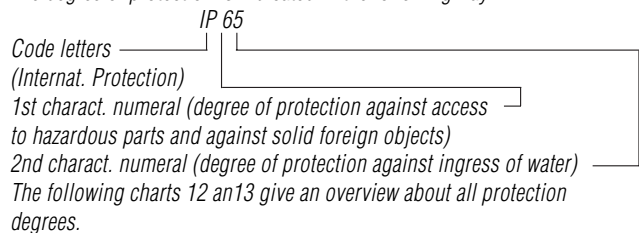

Chart 12

1st charact. numeral	Brief description	Definition
0	Non-protected	–
1	Protected against access to hazardous parts with the back of a hand. Protected against solid foreign objects of ≥ 50 mm \varnothing .	The probe, sphere of 50mm \varnothing , shall not fully penetrate and shall have adequate clearance from hazardous parts.
2	Protected against access to hazardous parts with a finger. Protected against solid foreign objects of $\geq 12,5$ mm \varnothing .	The jointed test finger of 12mm \varnothing , 80mm length, shall have adequate clearance from hazardous parts. The probe, sphere of 12,5mm \varnothing , shall not fully penetrate.
3	Protected against access to hazardous parts with a tool. Protected against solid foreign objects of $\geq 2,5$ mm \varnothing .	The probe of 2,5mm \varnothing shall not penetrate at all.
4	Protected against access to hazardous parts with a wire. Protected against solid foreign objects of ≥ 1 mm \varnothing .	The probe of 1mm \varnothing shall not penetrate at all.
5	Protected against access to hazardous parts with a wire. Dust-protected.	The probe of 1mm \varnothing shall not penetrate. Intrusion of dust is not totally prevented, but dust shall not penetrate in a quantity to interfere with satisfactory operation of the device or to impair safety.
6	Protected against access to hazardous parts with a wire. Dust-tight.	The probe of 1mm \varnothing shall not penetrate. No intrusion of dust.

Tabelle 13

2. Kennziffer	Kurzbeschreibung	Definition
0	Nicht geschützt	–
1	Geschützt gegen Tropfwasser	Senkrecht fallende Tropfen dürfen keine schädlichen Wirkungen haben.
2	Geschützt gegen Tropfwasser, wenn das Gehäuse bis zu 15° geneigt ist	Senkrecht fallende Tropfen dürfen keine schädlichen Wirkungen haben, wenn das Gehäuse um einen Winkel bis zu 15° beiderseits der Senkrechten geneigt ist.
3	Geschützt gegen Sprühwasser	Wasser, das in einem Winkel bis zu 60° beiderseits der Senkrechten gesprüht wird, darf keine schädlichen Wirkungen haben.
4	Geschützt gegen Spritzwasser	Wasser, das aus jeder Richtung gegen das Gehäuse spritzt, darf keine schädlichen Wirkungen haben.
5	Geschützt gegen Strahlwasser	Wasser, das aus jeder Richtung als Strahl gegen das Gehäuse gerichtet ist, darf keine schädlichen Wirkungen haben.
6	Geschützt gegen starkes Strahlwasser	Wasser, das aus jeder Richtung als starker Strahl gegen das Gehäuse gerichtet ist, darf keine schädlichen Wirkungen haben.
7	Geschützt gegen die Wirkungen beim zeitweiligen Untertauchen in Wasser	Wasser darf nicht in einer Menge eintreten, die schädliche Wirkungen verursacht, wenn das Gehäuse für 30 Min. in 1m Tiefe in Wasser untergetaucht ist.
8	Geschützt gegen die Wirkungen beim dauernden Untertauchen in Wasser	Wasser darf nicht in einer Menge eintreten, die schädliche Wirkungen verursacht, wenn das Gehäuse dauernd unter Wasser getaucht ist unter Bedingungen, die zwischen Hersteller und Anwender vereinbart werden müssen. Die Bedingungen müssen jedoch schwieriger sein als für die Kennziffer 7.
9K ¹⁾	Geschützt gegen Wasser bei Hochdruck-/Dampfstrahl-Reinigung	Wasser, das aus jeder Richtung unter stark erhöhtem Druck gegen das Gehäuse gerichtet ist, darf keine schädlichen Wirkungen haben.

1) Anmerkung: Kennziffer nach DIN 40050 Teil 9 Straßenfahrzeuge, IP-Schutzarten

Chart 13

2nd charact. numeral	Brief description	Definition
0	Non-protected	–
1	Protected against vertically falling water drops	Vertically falling drops shall have no harmful effects.
2	Protected against vertically falling water drops when enclosure tilted up to 15°	Vertically falling drops shall have no harmful effects when the enclosure is tilted at any angle up to 15°.
3	Protected against spraying water	Water sprayed at any angle up to 60° shall have no harmful effects.
4	Protected against splashing water	Water splashed against the enclosure from any direction shall have no harmful effects.
5	Protected against water jets	Water projected in jets against the enclosure from any direction shall have no harmful effects.
6	Protected against powerful water jets	Water projected in powerful jets against the enclosure from any direction shall have no harmful effects.
7	Protected against the effects of temporary immersion in water	Intrusion of water in quantities causing harmful effects shall not be possible when the enclosure is temporarily immersed in water for 30 min. in 1m depth.
8	Protected against the effects of continuous immersion in water	Intrusion of water in quantities causing harmful effects shall not be possible when the enclosure is continuously immersed in water under conditions which shall be agreed between manufacturer and user but which are more severe than for numeral 7.
9 K ¹⁾	Protected against water during high pressure/steam jet cleaning	Water projected in powerful jets with high pressure and heat against the enclosure from any direction shall have no harmful effects.

1) Remark: Numeral acc. to DIN 40050 part 9, vehicles IP code

Kabel

Zum Anschluss an alle Amphenol-Industrie-Steckverbinder wird die Verwendung von handelsüblichen hochflexiblen Kunststoff-Steuerleitungen nach VDE-Vorschriften empfohlen. Auf diese Leitungen sind unsere Steckverbinder in Bezug auf Kontaktanzahl und Kabeleinführung ausgelegt.

Bei der Leitungsauswahl ist darauf zu achten, dass die Leitungen den Steckverbinder nicht angreifen (Lösungsmittel) oder eine mögliche Feuerbeständigkeit aufheben.

Abdichtung

Die Abdichtung der Kabeleinführungen aller Amphenol-Industrie-Steckverbinder erfolgt mittels Verschraubungen. Wir verwenden grundsätzlich Dichtringe aus Neoprene, die eine gute Beständigkeit gegen Fette, Öle und Benzin besitzen.

Auswahl der Verschraubungen

Neben Dichtringen mit konstantem Innendurchmesser, dessen Maß der Bezeichnung der Verschraubung entspricht, gibt es auch ausschneidbare Dichtringe (Zwiebelringe), bei denen der Innendurchmesser durch Ausschneiden von Ringen in einem gewissen Maße variiert werden kann. Die Auswahl der Verschraubung für verschiedene Kabeldurchmesser (Kabelaufbau) kann von nachfolgendem Diagramm 5 abgeleitet werden (siehe auch Seite 194).

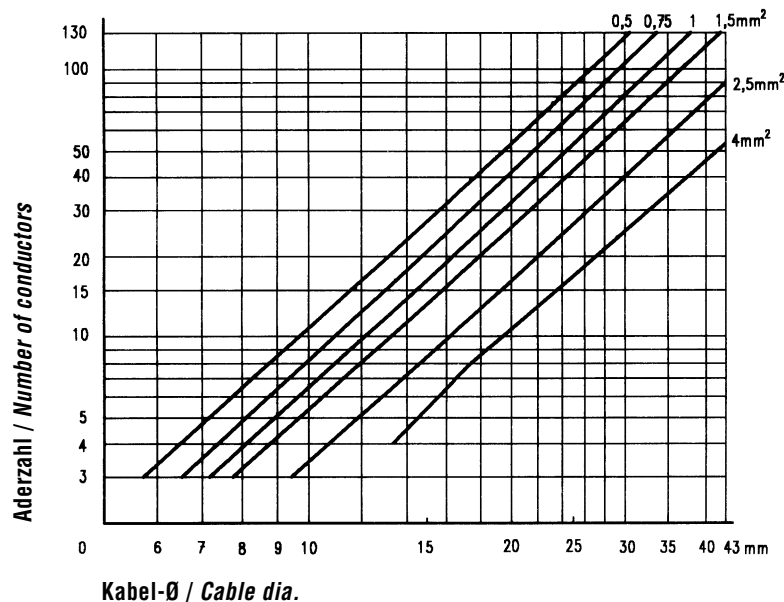
Diagramm 5**Cable**

For the termination of all Amphenol-industrial connectors we recommend the use of commercially available high flexible cable acc. to VDE or other local specifications. Our connectors are designed to fit these cables especially as far as number of conductors and cable diameters are concerned.

When selecting cables care must be taken that the cables do not affect (solvent) the connector or preserve an existing fire resistance.

Sealing

The sealing of the cable entries of all Amphenol-industrial connectors is with gland bushings. All sealings are made from Neoprene which has a good resistance against grease, oil and gasoline.

Selection of gland bushings

Beside glands with a fixed inside diameter which equals the number, there are also glands with variable inside diameters available (so-called onion glands). The inside diameter of these glands can be adjusted to the outside cable diameter by cutting out the smaller rings.

The selection of the appropriate gland bushing depends on the cable diameter (cable composition) can be made using the following diagram 5 (see page 194).

Diagram 5

Metrisch / Metric

PG / PG

PG 48

PG 42

PG 36

PG 29

PG 21

M 63

PG 16

M 50

PG 13,5

M 40

PG 11

M 32

PG 9

M 25

PG 7

M 20

M 16

M 12

Dichtbereich / Area of Tightness

Metrische Kabelverschraubungen passen nur in metrische Gehäuseöffnungen. Zusätzlich bieten wir weiterhin Gehäuse und Verschraubungen mit PG-Gewinde an.

Metric cable glands fit only into metric housing openings. Additionally we offer further more housings and screw connections with PG threads.

	PG / PG	Metrisch / Metric
Aussendurchmesser/ Outer Diameter	PG 48	M 63
	PG 42	
	PG 36	M 50
	PG 29	M 40
	PG 21/23	M 32
	PG 16	M 25
	PG 13,5	M 20
	PG 11	
	PG 9	M 16
	PG 7	M 12

Abschirmung

Abschirmung innerer oder äußerer elektrischer Felder durch Bildung einer Äquipotentialfläche in Form von Metallklappen oder Metallisierungen auf der Innen- und Außenseite von Kapfen aus Kunststoff. Die Abschirmung wird in der Regel mit dem Schirmgeflecht des angeschlossenen Kabels und mit dem Gerätegehäuse verbunden.

Bemessungsgrößen, elektrische

- Bemessungsspannung ist die Spannung, für die der Steckverbinder oder die Steckvorrichtung bemessen ist und auf die bestimmte Betriebseigenschaften bezogen werden.
- Bemessungsstrom ist der Strom, den ein Steckverbinder oder eine Steckvorrichtung gleichzeitig durch alle Kontakte dauernd (nicht intermittierend) führen kann, ohne dass dabei die obere Grenztemperatur überschritten wird.
- Schaltleistung einer Steckvorrichtung ist die Leistung, welche die Steckvorrichtung unter festgelegten Bedingungen schalten kann.
- Prüfspannung ist die Spannung, der ein Steckverbinder oder eine Steckvorrichtung bei vorgegebenen Bedingungen ohne Durch- oder Überschlager widersteht.

Bügelverriegelung

Verriegelung von zwei Hälften eines Steckverbinderpaares durch ein formschlüssiges Element, das durch einen als Bügel ausgestalteten Hebel betätigt wird. Erst wenn die beiden Hälften vollständig zusammengesteckt sind, kommt der Bügel in seine Endlage.

Crimpbacken

Derjenige Teil eines Crimpwerkzeugs, der den Crimpbereich verformt. Er besteht üblicherweise aus dem Crimpamboss, dem Crimpstempel und dem Positionierstück.

Crimpbereich

Der Bereich der Crimpöhse, in dem die Crimpverbindung durch Druckverformung oder Druckumformung der Hülse um den Leiter herum ausgeführt ist.

Crimphülse

Eine Anschlussöhse, die einen oder mehrere Leiter aufnehmen kann und durch Anwendung eines Crimpwerkzeugs gecrimpt werden kann.

Crimpverbindung

Durch systematisches Verformen einer Crimphülse um abisolierte Leiter herum hergestellte, dauerhafte elektrische und mechanische Verbindung; Crimpverbindung siehe IEC 60352-2, 2a; 2b; 2c, DIN EN 60 352-2 (siehe auch Katalog „Werkzeuge“)

Durchgangswiderstand

Der elektrische Widerstand in einem gesteckten bzw. geschalteten Kontaktpaar, gemessen zwischen den Anschlusspunkten unter vorgeschriebenen Messbedingungen. Prüfungen nach IEC 60512-2, DIN EN 60 512-2

Elektromagnetische Einflüsse

Bei Steckverbindern werden unerwünschte elektromagnetische Einflüsse auf die zu verbindenden Leitungen bzw. auf die Umgebung durch Abschirmung verhindert.

Gehäuse

Teil eines Steckverbinders, in dem Kontaktträger und Kontakte montiert sind. Es kann zur Verriegelung dienen.

Grenztemperaturen

Untere und obere Temperaturen, die nicht zu einer Schädigung der Werkstoffe führen; dazwischen liegt der Betriebstemperaturbereich.

- Untere Grenztemperatur: Die tiefste zulässige Temperatur, bei der ein Steckverbinder oder eine Steckvorrichtung noch betrieben werden darf.
- Obere Grenztemperatur: Die höchste zulässige Temperatur, bei der ein Steckverbinder oder eine Steckvorrichtung noch betrieben werden darf. Sie ist die Summe aus Eigenerwärmung (einschließlich Kontaktwärmerung) und Umgebungstemperatur.

Isolationswiderstand

Widerstand der Isolierung zwischen zwei leitfähigen Teilen. Isoliervermögen eines Werkstoffes, der zwei benachbarte Kontakte oder einen Kontakt gegen Masse möglichst hochohmig trennt. Mess- und Prüfverfahren nach IEC 60512-2, 3a, DIN EN 60 512-2

Isolierstoffgruppe

Einteilung von Isolierstoffen entsprechend ihren CTI-Werten (CTI = Comparative Tracking Index / Vergleichszahl der Kriechwegbildung).

Kompatible Steckverbinder

Zwei Steckverbinder sind kompatibel, wenn sie mechanisch austauschbar und zusammensteckbar sind und den gleichen technischen Anforderungen entsprechen.

Kontaktgröße

Kennzeichnung zur Differenzierung der Kontakte nach folgendem Systemen

- a) Kennzeichnungssystem: Kennzeichnung des Kontaktes nach der maximal anschließbaren Leitergröße (AWG American Wire Gauge);

- b) Strombelastbarkeitssystem: Kennzeichnung des Kontaktes nach seiner maximalen Strombelastbarkeit.

- c) Querschnittssystem: Kennzeichnung des Kontaktes nach dem maximal anschließbaren Leiterquerschnitt. Leiterwiderstand.

Kontaktmaterial

Die Wahl des Kontaktmaterials – meist Kupfer oder Kupferlegierungen – hängt von den gewünschten Eigenschaften des Steckverbinders ab. Hierbei spielen Durchgangswiderstand; Steck- und Ziehkräfte eine maßgebliche Rolle. Neben Stechkäufigkeit und Umwelteinflüssen bestimmen diese auch die Art der Oberflächenüberzüge Nickel, Zinn, Gold, Silber, Palladium. Sie werden galvanisch oder walztechnisch aufgebracht.

Kriechstrecken

Kürzeste Entfernung zwischen spannungsführenden Teilen auf der Oberfläche von Isolierkörpern, sofern festgelegte Mindestmaße vorliegen (Kriechstreckenverlängerung). Die Abstände dienen der Sicherheit gegen Überschlager. Sie werden in Abhängigkeit von der Reihenspannung, den Anwendungsbedingungen und den Eigenschaften des Isolierwerkstoffes festgelegt. Die unterschiedliche Kriechstromfestigkeit der Isolierstoffe ist bei der Festlegung der Kriechstrecken zu beachten (DIN VDE 0110-1.)

Lebensdauer

Anzahl der Steckzyklen, die noch nicht zum Durchrieb der leitenden Kontaktflächen führt und den Kontaktwiderstand nicht unzulässig erhöht. Mess- und Prüfverfahren nach IEC 60512-5, DIN EN 60512-5

Luftstrecken

Kürzeste, als Fadenmaß gemessene Entfernung zwischen zwei spannungsführenden Metallteilen in der Luft, nach DIN VDE 0110-1.

Rechteck-Verbinder

Steckverbinder mit vorwiegend rechteckiger Form des Steckgesichtes.

Schaltleistung

Die Schaltleistung einer Steckvorrichtung ist die Leistung, die die Steckvorrichtung unter festgelegten Bedingungen schalten kann.

Spannungsfestigkeit

Spannung, der ein Steckverbinder oder eine Steckvorrichtung bei vorgegebenen Bedingungen ohne Durchschlag oder Überschlager widersteht. Die Spannungsfestigkeit liegt über der Nennspannung, sie dient zum Nachweis des Isoliervermögens des Steckverbinders.

Steckverbinder

Ein Bauelement, das es gestattet elektrische Leiter anzuschließen, und dazu bestimmt ist, mit einem passenden Gegenstück Verbindungen herzustellen und zu trennen. Steckverbinder sind Betriebsmittel, die bei bestimmungsgemäßer Verwendung (unter elektrischer Spannung) nicht gesteckt oder getrennt werden dürfen (im Gegensatz Steckverbinder mit Schaltleistung). Nach der Befestigung werden freie und feste Steckverbinder unterschieden. Der Steckverbinder besteht aus dem Steckverbindergehäuse und den Kontaktelementen. Das Steckverbindergehäuse enthält den Kontakteinsatz.

Steckverbindung

Eine elektrische Steckverbindung besteht aus zwei Steckverbindern, d. h. aus mindestens zwei Kontaktelementen. Alle weiteren Komponenten wie Gehäuse, Kontaktträger, Kontakthalterung usw., erfüllen sekundäre Funktionen.

Steckverbinder mit Schaltleistung

Ein Bauelement, das bei bestimmungsgemäßer Verwendung unter elektrischer Spannung oder Last gesteckt oder getrennt wird. Der Schutzleiterkontakt muss während des Steckens vor- und während des Trennens naheilen (voreilender Kontakt).

Steckzyklen

Mechanisches Betätigen von Steckverbindern und Steckvorrichtungen durch Stecken und Ziehen. Ein Steckzyklus besteht aus je einem Steck- und Ziehvorgang.

Überspannungskategorie

Ein Zahlenwert, der eine Stehstoßspannung festlegt. Er werden die Überspannungskategorien I, II, III und IV verwendet.

Verschmutzungsgrad

Zahlenwert, der die zu erwartende Verschmutzung der Mikro-Umgebung angibt. Er werden die Verschmutzungsgrade 1, 2, 3 und 4 verwendet.

Voreilender Kontakt

Erfordert der Schaltungsaufbau, dass aus Schutzgründen, z. B. für Schutzleiter, ein oder mehrere Kontakte eines Steckverbinders beim Stecken zuerst Kontakt herstellen oder beim Ziehen als letzte getrennt werden, sind Steckverbinder mit voreilenden Kontakten (Stift bzw. Messer, Buchse oder Feder) zu verwenden.

American Wire Gauge (AWG)

System of numerical designations for wire sizes, based on specified ranges of cross-sectional areas. Starts with 4/0 (000) at the largest size, going to 3/0, 2/0, 1/0, 1, 2, and up to 40 and beyond for the smallest size. A step of one AWG number corresponds to a reduction of cross-sectional area of appr. 20 %.

Attenuation

A reduction of power. Occurs naturally when waves travel through lines, wave guides, or media such as air or water. Is produced additionally by imperfections in electrical or optical connections (attenuation in fibre optics), e. g. contact resistance, mismatch, etc.

Bulkhead connector

Connector designed to be inserted into a panel cutout from the rear of the panel, thus forming part of the barrier between two spaces. Back-mounted.

Clearance

The shortest distance in air between two conductive parts, see IEC 60664.

Climatic stability

General term describing the behavior of components under various climatic conditions, e. g. high and low temperatures, tropical climate, high humidity, moist heat, fungus, atmospheric conditions (industrial atmosphere), reduced air pressure, etc. Climatic conditions for test purposes are explained in IEC 60068, DIN 46 040.

Connector

A component which terminates conductors for the purpose of providing connection and disconnection to a suitable mating component which shall not be engaged or disengaged when live. Depending on the fastening to a cabinet, panel, rack etc. or a cable, they are classified as fixed or free connectors. A connector comprises one or more contacts and a housing which may have a separate connector insert and a separate outer housing or shell.

Connector housing

The part of a connector into which the insert and the contacts are assembled. It may function as part of the locking mechanism.

Connector insert

An insulating element designed to support and position contacts in a connector housing.

Connector life

The number of mating cycles prior to abrasion of the conductive contact surface and which does not result in a significant rise of the contact resistance. Tests according to test 9a of IEC 60512-5 / DIN EN 60512 Part 5.

Contact

The conductive element in a connector which mates with a corresponding element to provide an electrical path.

Contact resistance

The electrical resistance of a mated set of contacts under specified conditions. Tested according to tests 2a, 2b, 2c, of IEC 60 512 -2/ DIN EN 60 512-2.

Contact size

The designation used to differentiate one contact from another. It may be denoted by one of the following numbering systems:

- numbering system: assigned numbers used to denote the size of the contact and its related conductor accommodation (e. g. in AWG units),
- current rating system: the related current-carrying capacity is used to denote the size of the contact,
- cross-sectional area system: reference is made to the cross-sectional area of the maximum conductor accommodation to denote the size of the contact, e. g. in mm².

Creepage distance

The shortest distance along the surface of the insulating material between two conductive parts. The longer the distance, the less the risk of arc damage or tracking. Minimum creepage distances are specified according to the rated voltage and the applicable pollution degree and Comparative Tracking Index.

Crimped connection

A solderless connection made by crimping. IEC 60352-2 / DIN IEC 60352 Part 2.

Crimping die

That part of a crimping tool which forms the crimp(s) and usually incorporates the crimp anvil(s) and the crimp indentor(s).

Derating curve

The method for determining derating is specified in IEC 60 512-3. Here the combination of ambient temperature (T_u) and the current (I) leading to the same maximum allowable temperature (T_b) at the hottest point of the connector are plotted.

DIN

Deutsches Institut für Normung. A German standards organization.

Electromagnetic interference (EMI)

General term describing the undesirable effects of the immission or emission of radio frequency fields. In connectors electromagnetic interference is prevented by shielding. Shielded connectors normally provide means to connect the screens of attached cables.

Funnel entry (restricted entry C146 D series)

Flared or widened entrance to a conductor barrel permitting easier insertion of the conductor.

Insertion or withdrawal force

The force required to fully insert or withdraw a set of mated connectors without the effect of coupling, locking or similar devices. The insertion force is usually greater than the withdrawal force.

Insulation grip

The area of a crimp contact that has been reshaped around the insulation of the conductor by compression during the crimping operation.

Insulation resistance

The resistance of the insulation between two conductive elements, in particular, the resistance between two contacts or between a contact and a metallic housing or shield. Tested according to test 3a of IEC 60512-2 / DIN IEC 60512 Part 2.

Intermateable

Two connectors are intermateable when they are capable of being connected electrically and mechanically but without regard to their performance and intermountability.

Locator

In a crimping tool the device used for positioning a crimp contact or terminal end.

Locking lever

A mechanical locking device operated by actuating a lever, designed to hold two mated connectors together. Typically the lever can only be fully locked if the two connectors are correctly mated.

Mating cycle

One mating cycle comprises one insertion and one withdrawal operation. Term used in the definition of connector life.

Material group

Classification of insulation materials according to their CTI values (CTI = Comparative Tracking Index)

Overvoltage category

A numeral defining a transient overvoltage condition. Overvoltage categories I, II, III and IV are used.

Connector with braking capacity (CBC)

A component which may be engaged or disengaged in normal use, when live or under load. Note: In the sense of this document the term - live- is used if contacts are under voltage not necessarily with a current flowing across the contacts. The term - load - is used if a current is flowing across the contacts.

Rated current

A current value assigned by the manufacturer which the connector or PSD can carry continuously (without interruption) and simultaneously through all its contacts wired with the largest conductor preferably at an ambient temperature of 40 °C without the upper temperature being exceeded.

Shield, shielding

Shielding of internal or external electric fields by means of a plane with a uniform electric potential, formed by metal shells or metallic layers on the inside or outside of plastic shells. The shield is normally connected to the shielding braid of the cable and/or chassis ground.

Terminal block

An assembly of terminals in a housing or body of insulating material to facilitate interconnection between multiple conductors. Also called terminal strip or barrier blocks if the terminals are separated by an insulation barrier.

Wire range

The range of wire cross sections which is compatible with the dimensions the terminals of the contact (wire barrel). The wire range is expressed in mm² or in AWG numbers.

Gestanzte Crimphülsen Serie C146 Abisolierlängen für anzuschließenden Leiter

Stamped crimp contacts series C146, stripping length

Anschlussquerschnitt [mm ²] Termination crimp [mm ²]	Leiterquerschnitt Wire gauge		Isolierungsdurchmesser der Leitung [mm] Insulation diameter of the wire [mm]	Mindestabisolierlänge mit Toleranz [mm] Min. stripping length [mm]	Kontakt Art.-Nr. Contact part No.	in Serie Series
	mm ²	AWG				
0,09 - 0,25	0,09 - 0,25	28 - 24	0,7 - 1,6	2,3 + 0,4	N01 010 0130 (2) N02 010 0130 (2)	C146M C146M
0,14 - 0,5	0,14	26	1,0 - 2,0	3,0 + 0,5	N01 016 0003 N02 016 0003	C146D/M C146D/M
	0,25	24-22				
	0,5	20				
0,25 - 0,5	0,25	24-22	1,6 - 2,0	2,3 + 0,4	N01 010 0131 (2) N02 010 0131 (2)	C146M C146M
	0,5	20				
0,5 - 1,5	0,5	20	1,8 - 2,8	3,5 + 1,0	N01 016 0002 N02 016 0002 N01 016 0015 N02 016 0015 N01 025 0001 N02 025 0001 N01 025 0007	C146D/M C146D/M C146D C146D C146E/M C146E/M/S C146S
	0,75	20 - 18				
	1,0	18 - 16				
	1,5	16 - 15				
1,5 - 2,5	1,5	16 - 15	2,5 - 3,5	3,5 + 1,0	N01 016 0005 N02 016 0005 N01 016 0016 N02 016 0016 N01 025 0010 N02 025 0010 N01 025 0008	C146D/M C146D/M C146D C146D C146E/M C146E/M/S C146S
	2,5	14				
2,5 - 4,0	2,5	14	3,3 - 4,2	3,5 + 1,0	N01 025 0043 N02 025 0043	C146M C146M
	4,0	12				

Gedrehte Crimpkontakte Serie C146 Abisolierlängen für anzuschließenden Leiter

Turned crimp contacts series C146, stripping length

Anschlussquerschnitt [mm ²] Termination crimp [mm ²]	1,6 (Kontakt ohne Clip) (Contact without clip)			2,5 (Kontakt mit Clip) (Contact with clip)			2,5 (Kontakt ohne Clip) (Contact without clip)			3,6 (Kontakt mit Clip) (Contact with clip)		
	Mind.abisolierlänge+Toleranz [mm] Min. stripping length+tolerance[mm]	Kontakt Art Nr. Contact part No.	in Serie Series	Mind.abisolierlänge+Toleranz [mm] Min. stripping length+tolerance[mm]	Kontakt Art Nr. Contact part No.	in Serie Series	Mind.abisolierlänge+Toleranz [mm] Min. stripping length+tolerance[mm]	Kontakt Art Nr. Contact part No.	in Serie Series	Mind.abisolierlänge+Toleranz [mm] Min. stripping length+tolerance[mm]	Kontakt Art Nr. Contact part No.	in Serie Series
0,14 - 0,37	8 + 1	N01 016 0024 N02 016 0024	C146 D/DD/M									
0,5	8 + 1	N01 016 0025 N02 016 0025	C146 D/DD/M	7 + 1	N01 025 0029 N02 025 0029	C146 M	7 + 1	N01 025 0035 N02 025 0035	C146 E/EE			
0,75 - 1,0	8 + 1	N01 016 0026 N02 016 0026	C146 D/DD/M	7 + 1	N01 025 0030 N02 025 0030	C146 M	7 + 1	N01 025 0036 N02 025 0036	C146 E/EE			
1,5	8 + 1	N01 016 0027 N02 016 0027	C146 D/DD/M	7 + 1	N01 025 0031 N02 025 0031	C146 M	7 + 1	N01 025 0037 N02 025 0037	C146 E/EE	10 + 1	N01 036 0004 N02 036 0004	C146 M
2,5	6 + 1	N01 016 0028 N02 016 0028	C146 D/DD/M	7 + 1	N01 025 0032 N02 025 0032	C146 M	7 + 1	N01 025 0038 N02 025 0038	C146 E/EE	10 + 1	N01 036 0005 N02 036 0005	C146 M
4,0				7 + 1	N01 025 0033 N02 025 0033	C146 M	7 + 1	N01 025 0039 N02 025 0039	C146 E/EE	10 + 1	N01 036 0001 N02 036 0001	C146 M
6,0										10 + 1	N01 036 0002 N02 036 0002	C146 M
10,0										10 + 1	N01 036 0003 N02 036 0003	C146 M

Zeitersparnis durch den Einsatz von gestanzten Kontakten
Time saving through the introduction of stamped contacts

Verdrahtungskosten verschiedener Anschlussarten
Wiring costs of different contacts

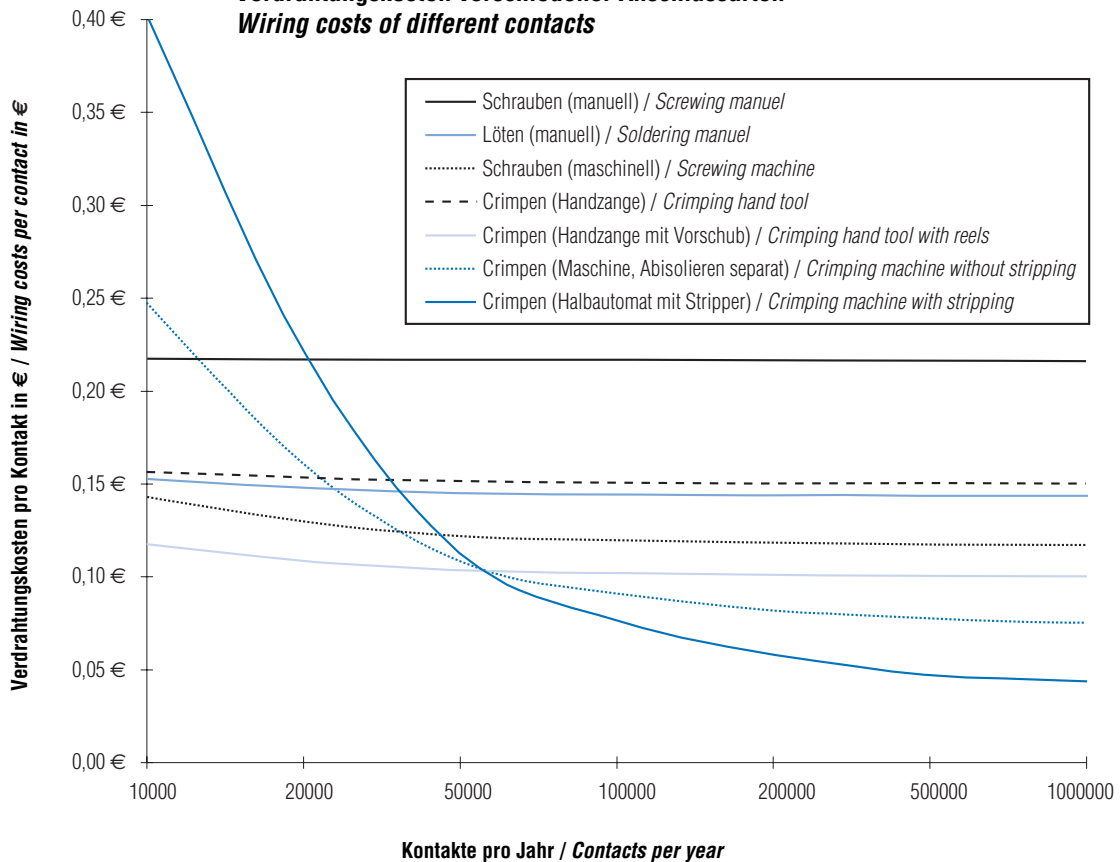

Break Even bei
ca. 60.000 Kontakten pro Jahr / contacts per year

Rahmenbedingungen / General conditions:	
Laufzeit (Abschreibung) / Maturity (Depreciation)	5 Jahre / years
Zins / Interest	8%
Wartung / Maintenance	5%
Stundenlohn Bediener / Hourly wages	20 €

Unverbindliche Angaben beruhen auf uns vorliegenden Erfahrungswerten.
Non binding declarations are based on experienced values.

Bestellnummer / Part Number
FM 0300 146

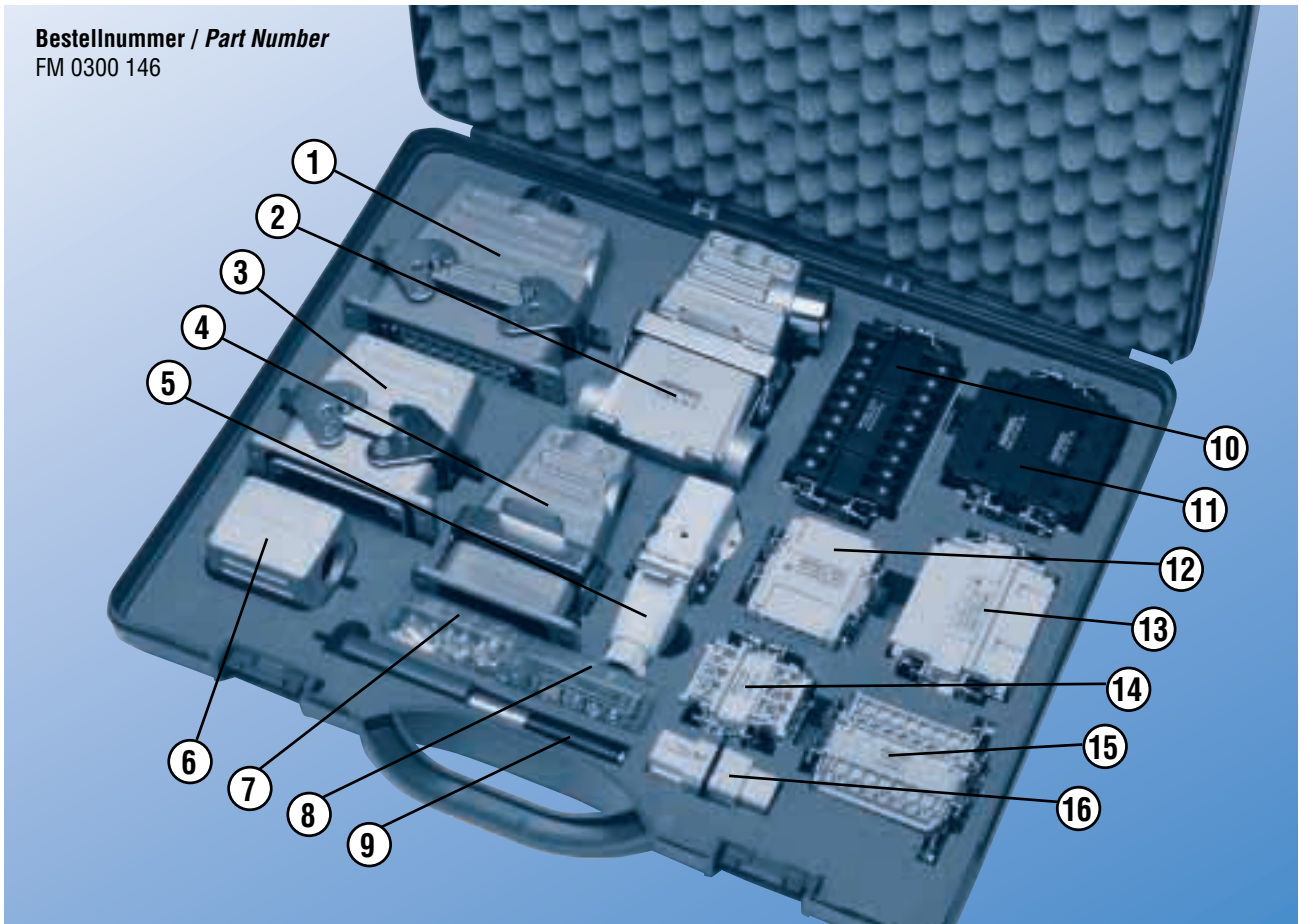

- | | |
|---|---|
| ① Steckverbinder Serie C 146 E 16 pol | ① Connector series C 146 E 16 contacts |
| ② Steckverbinder Serie C 146 A 10 pol | ② Connector series C 146 A 10 contacts |
| ③ EMV Gehäuse | ③ EMC housing |
| ④ Standard Gehäuse hohe Bauform ohne Stutzen | ④ Standard housing high profile without stud |
| ⑤ Steckverbinder Serie C 146 A 3 pol | ⑤ Connector series C 146 A 3 contacts |
| ⑥ EMV Tüllengehäuse | ⑥ EMC hood |
| ⑦ Gedrehte Crimpkontakte | ⑦ Turned crimp contacts |
| ⑧ Gestanzte Crimpkontakte | ⑧ Stamped crimp contacts |
| ⑨ Lösewerkzeug für 1,6 mm Kontakte | ⑨ Removal tool for 1,6 mm contacts |
| ⑩ Kontakteinsätze Serie C 146 HvE 16 pol | ⑩ Contact insert series C 146 HvE 16 contacts |
| ⑪ Rahmen und Module Serie C 146 M | ⑪ Frames and modules series C 146 M |
| ⑫ Kontakteinsätze Serie C 146 D 15 pol (für gedrehte Kontakte) | ⑫ Contact inserts series C 146 D 15 contacts (for turned contacts) |
| ⑬ Kontakteinsätze Serie C 146 D 40 pol (für gestanzte Kontakte) | ⑬ Contact inserts series C 146 D 40 contacts (for stamped contacts) |
| ⑭ Kontakteinsätze Serie C 146 E 6 pol | ⑭ Contact inserts series C 146 E 6 contacts |
| ⑮ Kontakteinsätze Serie C 146 A 16 pol | ⑮ Contact inserts series C 146 A 16 contacts |
| ⑯ Kontakteinsätze Serie C 146 D 7 pol | ⑯ Contact inserts series C 146 D 7 contacts |

Bestellnummer / Part Number

FM 0500 146

FM 0501 146 (ohne / without TB0200 146)

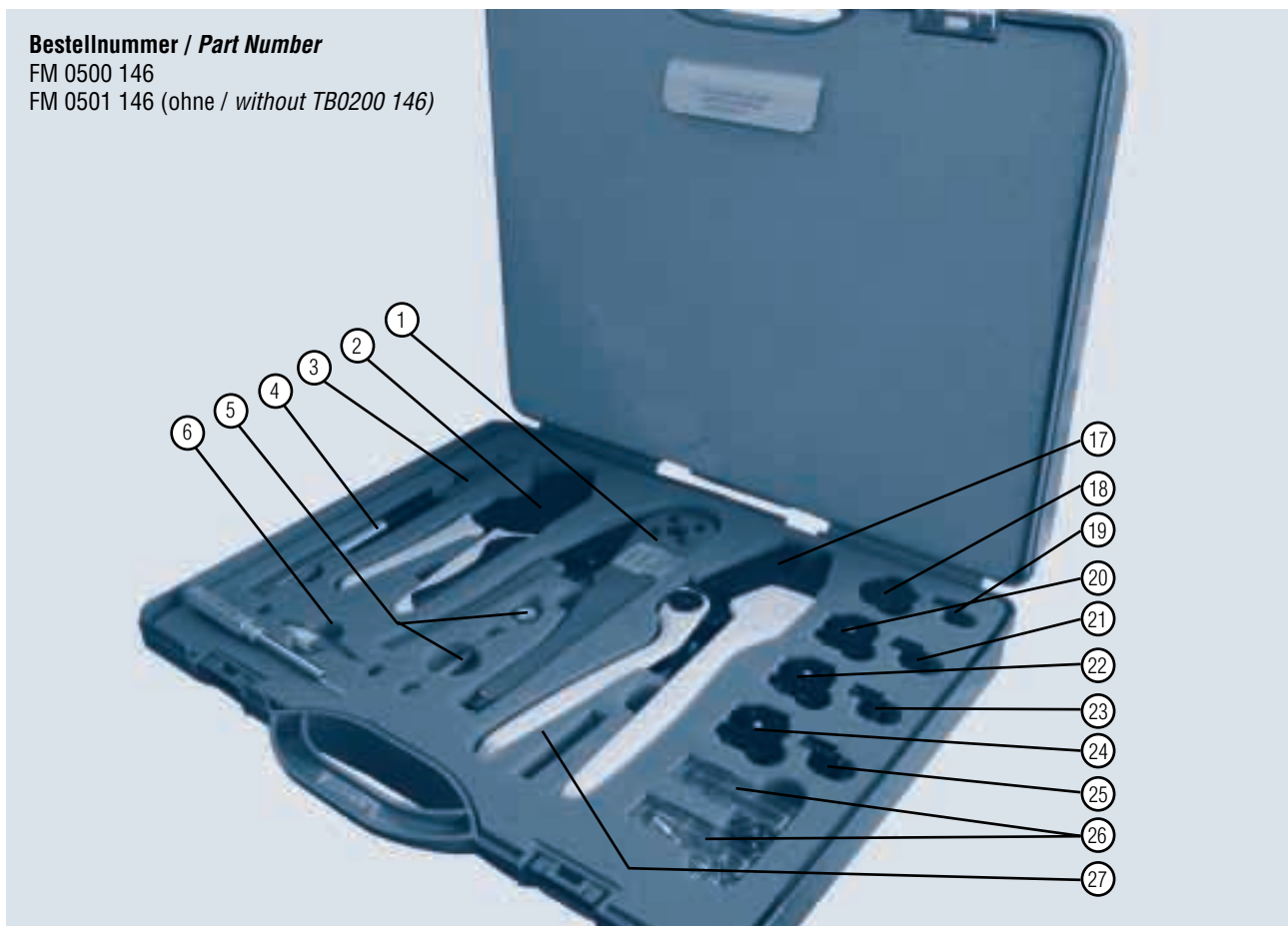

Bezeichnung	Description	Katalog „Werkzeuge“ / Catalogue „Tools“	
		Bestell-Nr./ Part No.	Seite / Page
1 4 - Kerb Crimpzange	1 4 - Indent hand crimping tool	TB 0200 146	9
2 Service Hand Crimpwerkzeug	2 Service hand crimping tool	TA 0200 146	12
3 Lösewerkzeug	3 Removal tool	FG 0300 146 1	17
4 Lösewerkzeug	4 Removal tool	FG 0300 146 3	17
5 Zubehör	5 Accessories	TB 0200 146	9
6 Lösewerkzeug	6 Removal tool	17D 438 SP	17
7 Zubehör	7 Accessories	TA 0000	5
8 Kontaktbehältnis	8 Contact container		
9 Kontaktaufnahme	9 Contact locator	TA 0001 146 0001	7
10 Crimpbacken	10 Crimping dies	TA 0000 202	7
11 Kontaktaufnahme	11 Contact locator	TA 0007 146 0003	7
12 Crimpbacken	12 Crimping dies	TA 0000 141	7
13 Kontaktaufnahme	13 Contact locator	TA 0002 146 0001	7
14 Crimpbacken	14 Crimping dies	TA 0000 163	7
15 Kontaktaufnahme	15 Contact locator	TA 0010 146 0004	7
16 Crimpbacken	16 Crimping dies	TA 0000124	7
17 Handcrimpwerkzeug	17 Hand crimping tool	TA 0000	5

Bestell Nr. / Part No.	Seite / Page	Bestell Nr. / Part No.	Seite / Page	Bestell Nr. / Part No.	Seite / Page	Bestell Nr. / Part No.	Seite / Page
17 DM 537 401	77, 189	C146 10A024 810 1	56	C146 10B016 002 4	90-91	C146 10F006 602 2	134
17 DM 537 405	77, 189	C146 10A025 000 2	14, 18	C146 10B016 004 4	91	C146 10F006 603 2	134
17 DM 537 421	77, 189	C146 10A025 005 2	18	C146 10B016 102 1	38	C146 10F006 606 1	134
17 DM 537 425	77, 189	C146 10A025 009 2	14	C146 10B016 102 3	103-104	C146 10F006 606 2	134
17D 438 SP	65, 84	C146 10A025 060 2	14	C146 10B016 102 4	90-91	C146 10F006 607 2	134
C146 10A003 002 4	88	C146 10A025 500 2	14, 18	C146 10B016 104 3	104	C146 10F006 802 2	134
C146 10A003 102 3	100	C146 10A025 505 2	18	C146 10B016 104 4	91	C146 10F006 803 2	134
C146 10A004 002 4	88	C146 10A032 500 10	46	C146 10B016 500 1	38	C146 10F006 806 1	134
C146 10A004 102 6	108	C146 10A040 000 2	16	C146 10B016 810 1	56	C146 10F006 806 2	134
C146 10A006 000 1	34	C146 10A040 009 2	16	C146 10B018 500 10	46	C146 10F006 807 2	134
C146 10A006 002 1	34	C146 10A040 060 2	16	C146 10B024 000 1	40, 42	C146 10F010 000 1	136-137
C146 10A006 102 1	34	C146 10A040 500 2	16	C146 10B024 000 9	26	C146 10F010 001 1	138-139
C146 10A006 102 3	101	C146 10A042 000 9	26	C146 10B024 002 1	40, 42	C146 10F010 002 1	140-141
C146 10A006 102 5	95	C146 10A046 500 10	46	C146 10B024 004 1	42	C146 10F010 003 1	138-139
C146 10A006 500 1	34	C146 10A057 000 6	110	C146 10B024 005 1	42	C146 10F010 090 1	136-137
C146 10A006 810 1	56	C146 10A057 801 6	110	C146 10B024 102 1	40, 42	C146 10F010 500 1	136
C146 10A007 000 2	10	C146 10A064 000 2	20, 22	C146 10B024 104 1	42	C146 10F010 500 2	136
C146 10A007 500 2	10	C146 10A064 005 2	22	C146 10B024 500 1	40, 42	C146 10F010 501 2	136
C146 10A008 000 2	10	C146 10A064 009 2	20	C146 10B024 505 1	42	C146 10F010 502 1	138
C146 10A008 500 2	10	C146 10A064 060 2	20	C146 10B024 810 1	56	C146 10F010 502 2	138
C146 10A010 000 1	36	C146 10A064 500 2	20, 22	C146 10B025 000 2	14, 18	C146 10F010 503 2	138
C146 10A010 002 1	36	C146 10A064 505 2	22	C146 10B025 005 2	18	C146 10F010 504 1	140
C146 10A010 002 4	89	C146 10A072 000 9	26	C146 10B025 009 2	14	C146 10F010 504 2	140
C146 10A010 102 1	36	C146 10A108 000 9	26-27	C146 10B025 060 2	14	C146 10F010 505 2	140
C146 10A010 102 3	102, 104	C146 10A108 005 9	27	C146 10B025 500 2	14, 18	C146 10F010 506 1	138
C146 10A010 102 3	102, 104	C146 10B003 002 4	88	C146 10B025 505 2	18	C146 10F010 506 2	138
C146 10A010 102 4	89	C146 10B003 102 3	100	C146 10B032 500 10	46	C146 10F010 507 2	138
C146 10A010 104 3	104	C146 10B004 002 4	88	C146 10B040 000 2	16	C146 10F010 508 2	140
C146 10A010 500 1	36	C146 10B004 102 6	108	C146 10B040 009 2	16	C146 10F010 509 2	140
C146 10A010 500 10	46	C146 10B006 000 1	34	C146 10B040 060 2	16	C146 10F010 600 1	136
C146 10A010 810 1	56	C146 10B006 002 1	34	C146 10B040 500 2	16	C146 10F010 600 2	136
C146 10A015 000 2	12	C146 10B006 102 1	34	C146 10B042 000 9	26	C146 10F010 601 2	136
C146 10A015 009 2	12	C146 10B006 102 3	101	C146 10B046 500 10	46	C146 10F010 602 1	138
C146 10A015 060 2	12	C146 10B006 102 5	95	C146 10B057 000 6	110	C146 10F010 602 2	138
C146 10A015 500 2	12	C146 10B006 500 1	34	C146 10B057 801 6	110	C146 10F010 603 2	138
C146 10A016 000 1	38	C146 10B006 810 1	56	C146 10B064 000 2	20, 22	C146 10F010 604 1	140
C146 10A016 002 1	38	C146 10B007 000 2	10	C146 10B064 005 2	22	C146 10F010 604 2	140
C146 10A016 002 3	103	C146 10B007 500 2	10	C146 10B064 009 2	20	C146 10F010 605 2	140
C146 10A016 002 4	90-91	C146 10B008 000 2	10	C146 10B064 060 2	20	C146 10F010 606 1	138
C146 10A016 004 4	91	C146 10B008 500 2	10	C146 10B064 500 2	20, 22	C146 10F010 606 2	138
C146 10A016 102 1	38	C146 10B010 000 1	36	C146 10B064 505 2	22	C146 10F010 607 2	138
C146 10A016 102 3	103-104	C146 10B010 002 1	36	C146 10B072 000 9	26	C146 10F010 608 2	140
C146 10A016 102 4	90-91	C146 10B010 002 4	89	C146 10B108 000 9	26-27	C146 10F010 609 2	140
C146 10A016 104 3	104	C146 10B010 102 1	36	C146 10B108 005 9	27	C146 10F010 802 1	138
C146 10A016 104 4	91	C146 10B010 102 3	102, 104	C146 10F003 000 4	116-117	C146 10F010 802 2	138
C146 10A016 500 1	38	C146 10B010 102 4	89	C146 10F003 004 4	116-117	C146 10F010 803 2	138
C146 10A016 810 1	56	C146 10B010 104 3	104	C146 10F003 500 4	116	C146 10F010 804 1	140
C146 10A018 500 10	46	C146 10B010 500 1	36	C146 10F006 000 1	132-133	C146 10F010 804 2	140
C146 10A024 000 1	40, 42	C146 10B010 500 10	46	C146 10F006 003 1	132-133	C146 10F010 805 2	140
C146 10A024 000 9	26	C146 10B010 810 1	56	C146 10F006 500 1	134	C146 10F010 806 1	138
C146 10A024 002 1	40, 42	C146 10B015 000 2	12	C146 10F006 502 1	134	C146 10F010 806 2	138
C146 10A024 004 1	42	C146 10B015 009 2	12	C146 10F006 502 2	134	C146 10F010 807 2	138
C146 10A024 005 1	42	C146 10B015 060 2	12	C146 10F006 503 2	134	C146 10F015 000 2	120-121
C146 10A024 102 1	40, 42	C146 10B015 500 2	12	C146 10F006 506 1	134	C146 10F015 003 2	120-121
C146 10A024 104 1	42	C146 10B016 000 1	38	C146 10F006 506 2	134	C146 10F015 500 2	122
C146 10A024 500 1	40, 42	C146 10B016 002 1	38	C146 10F006 507 2	134	C146 10F015 501 2	122
C146 10A024 505 1	42	C146 10B016 002 3	103	C146 10F006 600 1	134	C146 10F015 600 2	122

Bestell Nr. / Part No.	Seite / Page	Bestell Nr. / Part No.	Seite / Page	Bestell Nr. / Part No.	Seite / Page	Bestell Nr. / Part No.	Seite / Page
C146 10F015 601 2	122	C146 10F032 002 4	130-131	C146 10G003 804 4	116	C146 10G015 501 2	120
C146 10F015 606 2	122	C146 10F032 500 4	130	C146 10G006 500 1	132	C146 10G015 600 2	120
C146 10F015 607 2	122	C146 10F032 501 4	130	C146 10G006 501 1	132	C146 10G015 601 2	120
C146 10F015 806 2	122	C146 10F032 600 4	130	C146 10G006 506 8	132	C146 10G015 804 2	120
C146 10F015 807 2	122	C146 10F032 601 4	130	C146 10G006 507 8	132	C146 10G016 500 1	144
C146 10F016 000 1	144-145	C146 10F040 500 2	144	C146 10G006 556 8	132	C146 10G016 500 4	124
C146 10F016 001 1	146-147	C146 10F040 501 2	144	C146 10G006 600 1	132	C146 10G016 500 8	144
C146 10F016 002 1	148-149	C146 10F040 502 2	146	C146 10G006 601 1	132	C146 10G016 501 1	144
C146 10F016 003 1	146-147	C146 10F040 503 2	146	C146 10G006 606 8	132	C146 10G016 501 4	124
C146 10F016 500 1	144	C146 10F040 504 2	148	C146 10G006 607 8	132	C146 10G016 501 8	144
C146 10F016 502 1	146	C146 10F040 505 2	148	C146 10G006 656 8	132	C146 10G016 502 1	148
C146 10F016 504 1	148	C146 10F040 506 2	146	C146 10G006 804 1	132	C146 10G016 502 8	148
C146 10F016 506 1	146	C146 10F040 507 2	146	C146 10G006 804 8	132	C146 10G016 503 1	148
C146 10F016 508 2	148	C146 10F040 600 2	144	C146 10G006 805 1	132	C146 10G016 503 8	148
C146 10F016 509 2	148	C146 10F040 601 2	144	C146 10G006 805 8	132	C146 10G016 506 1	146
C146 10F016 600 1	144	C146 10F040 602 2	146	C146 10G010 500 1	136	C146 10G016 506 8	146
C146 10F016 602 1	146	C146 10F040 603 2	146	C146 10G010 500 4	120	C146 10G016 507 1	146
C146 10F016 604 1	148	C146 10F040 604 2	148	C146 10G010 500 8	136	C146 10G016 507 8	146
C146 10F016 606 1	146	C146 10F040 605 2	148	C146 10G010 501 1	136	C146 10G016 600 1	144
C146 10F016 608 2	148	C146 10F040 606 2	146	C146 10G010 501 4	120	C146 10G016 600 4	124
C146 10F016 609 2	148	C146 10F040 607 2	146	C146 10G010 501 8	136	C146 10G016 600 8	144
C146 10F016 802 1	146	C146 10F040 802 2	146	C146 10G010 502 1	140	C146 10G016 601 1	144
C146 10F016 804 1	148	C146 10F040 803 2	146	C146 10G010 502 8	140	C146 10G016 601 8	144
C146 10F016 806 1	146	C146 10F040 804 2	148	C146 10G010 503 1	140	C146 10G016 602 1	148
C146 10F024 000 1	152-153	C146 10F040 805 2	148	C146 10G010 503 8	140	C146 10G016 602 8	148
C146 10F024 000 3	164-165	C146 10F040 806 2	146	C146 10G010 506 1	138	C146 10G016 603 1	148
C146 10F024 001 1	154-155	C146 10F040 807 2	146	C146 10G010 506 8	138	C146 10G016 603 8	148
C146 10F024 002 1	156-157	C146 10F048 001 1	162-163	C146 10G010 507 1	138	C146 10G016 606 1	146
C146 10F024 003 1	154-155	C146 10F048 003 1	162-163	C146 10G010 507 8	138	C146 10G016 606 8	146
C146 10F024 500 1	152	C146 10F048 802 1	162	C146 10G010 550 8	136	C146 10G016 607 1	146
C146 10F024 500 3	164	C146 10F048 803 1	162	C146 10G010 600 1	136	C146 10G016 607 8	146
C146 10F024 502 1	154	C146 10F048 806 1	162	C146 10G010 600 4	120	C146 10G016 802 1	144
C146 10F024 504 1	156	C146 10F048 807 1	162	C146 10G010 600 8	136	C146 10G016 802 8	144
C146 10F024 506 1	154	C146 10F064 500 2	152	C146 10G010 601 1	136	C146 10G016 803 1	144
C146 10F024 508 2	156	C146 10F064 501 2	152	C146 10G010 601 4	120	C146 10G016 803 8	144
C146 10F024 509 2	156	C146 10F064 502 2	154	C146 10G010 601 8	136	C146 10G016 804 1	146
C146 10F024 600 1	152	C146 10F064 503 2	154	C146 10G010 602 1	140	C146 10G016 804 4	124
C146 10F024 600 3	164	C146 10F064 504 2	156	C146 10G010 602 8	140	C146 10G016 804 8	146
C146 10F024 602 1	154	C146 10F064 505 2	156	C146 10G010 603 1	140	C146 10G016 805 1	146
C146 10F024 604 1	156	C146 10F064 506 2	154	C146 10G010 603 8	140	C146 10G016 805 4	124
C146 10F024 606 1	154	C146 10F064 507 2	154	C146 10G010 606 1	138	C146 10G016 805 8	146
C146 10F024 608 2	156	C146 10F064 600 2	152	C146 10G010 606 8	138	C146 10G016 902 8	150
C146 10F024 609 2	156	C146 10F064 601 2	152	C146 10G010 607 1	138	C146 10G024 500 1	152
C146 10F024 802 1	154	C146 10F064 602 2	154	C146 10G010 607 8	138	C146 10G024 500 3	164
C146 10F024 804 1	156	C146 10F064 603 2	154	C146 10G010 650 8	136	C146 10G024 500 8	152
C146 10F024 806 1	154	C146 10F064 604 2	156	C146 10G010 802 1	136	C146 10G024 501 1	152
C146 10F025 000 2	124-125	C146 10F064 605 2	156	C146 10G010 802 8	136	C146 10G024 501 8	152
C146 10F025 003 2	124-125	C146 10F064 606 2	154	C146 10G010 803 1	136	C146 10G024 502 1	156
C146 10F025 500 2	126	C146 10F064 607 2	154	C146 10G010 803 8	136	C146 10G024 502 8	156
C146 10F025 501 2	126	C146 10F064 802 2	154	C146 10G010 804 1	138	C146 10G024 503 1	156
C146 10F025 600 2	126	C146 10F064 803 2	154	C146 10G010 804 4	120	C146 10G024 503 8	156
C146 10F025 601 2	126	C146 10F064 804 2	156	C146 10G010 804 8	138	C146 10G024 506 1	154
C146 10F025 606 2	126	C146 10F064 805 2	156	C146 10G010 805 1	138	C146 10G024 506 8	154
C146 10F025 607 2	126	C146 10F064 806 2	154	C146 10G010 805 4	120	C146 10G024 507 1	154
C146 10F025 806 2	126	C146 10F064 807 2	154	C146 10G010 805 8	138	C146 10G024 507 8	154
C146 10F025 807 2	126	C146 10G003 500 4	116	C146 10G010 902 8	142	C146 10G024 600 1	152
C146 10F032 000 4	130-131	C146 10G003 600 4	116	C146 10G015 500 2	120	C146 10G024 600 3	164

Bestell Nr. / Part No.	Seite / Page	Bestell Nr. / Part No.	Seite / Page	Bestell Nr. / Part No.	Seite / Page	Bestell Nr. / Part No.	Seite / Page
C146 10G024 600 8	152	C146 10N006 709 1	135	C146 10N010 803 1	139	C146 10N016 802 1	147
C146 10G024 601 1	152	C146 10N006 802 1	135	C146 10N010 803 2	139	C146 10N016 802 2	147
C146 10G024 601 8	152	C146 10N006 802 2	135	C146 10N010 804 1	141	C146 10N016 803 2	147
C146 10G024 602 1	156	C146 10N006 803 1	135	C146 10N010 804 2	141	C146 10N016 804 1	149
C146 10G024 602 8	156	C146 10N006 803 2	135	C146 10N010 805 1	141	C146 10N016 804 2	149
C146 10G024 603 1	156	C146 10N006 806 1	135	C146 10N010 805 2	141	C146 10N016 805 2	149
C146 10G024 603 8	156	C146 10N006 806 2	135	C146 10N010 806 1	139	C146 10N016 806 1	147
C146 10G024 606 1	154	C146 10N006 807 1	135	C146 10N010 806 2	139	C146 10N016 806 2	147
C146 10G024 606 8	154	C146 10N006 807 2	135	C146 10N010 807 1	139	C146 10N016 807 2	147
C146 10G024 607 1	154	C146 10N010 500 1	137	C146 10N010 807 2	139	C146 10N016 808 1	149
C146 10G024 607 8	154	C146 10N010 500 2	137	C146 10N010 808 1	141	C146 10N016 808 2	149
C146 10G024 802 1	152	C146 10N010 501 1	137	C146 10N010 809 1	141	C146 10N016 809 2	149
C146 10G024 802 3	164	C146 10N010 501 2	137	C146 10N015 500 2	123	C146 10N024 500 1	153
C146 10G024 802 8	152	C146 10N010 502 1	139	C146 10N015 501 2	123	C146 10N024 500 2	153
C146 10G024 803 1	152	C146 10N010 502 2	139	C146 10N015 600 2	123	C146 10N024 500 3	165
C146 10G024 803 8	152	C146 10N010 503 1	139	C146 10N015 601 2	123	C146 10N024 501 2	153
C146 10G024 804 1	154	C146 10N010 503 2	139	C146 10N015 606 2	123	C146 10N024 502 1	155
C146 10G024 804 8	154	C146 10N010 504 1	141	C146 10N015 607 2	123	C146 10N024 502 2	155
C146 10G024 805 1	154	C146 10N010 504 2	141	C146 10N015 702 2	123	C146 10N024 503 2	155
C146 10G024 805 8	154	C146 10N010 505 1	141	C146 10N015 703 2	123	C146 10N024 504 1	157
C146 10G024 903 8	158	C146 10N010 505 2	141	C146 10N015 708 2	123	C146 10N024 504 2	157
C146 10G024 908 8	158	C146 10N010 506 1	139	C146 10N015 709 2	123	C146 10N024 505 2	157
C146 10G025 500 2	124	C146 10N010 506 2	139	C146 10N015 806 2	123	C146 10N024 506 1	155
C146 10G025 501 2	124	C146 10N010 507 1	139	C146 10N015 807 2	123	C146 10N024 506 2	155
C146 10G025 600 2	124	C146 10N010 507 2	139	C146 10N016 500 1	145	C146 10N024 507 2	155
C146 10G025 601 2	124	C146 10N010 508 1	141	C146 10N016 500 2	145	C146 10N024 508 1	157
C146 10G025 804 2	124	C146 10N010 508 2	141	C146 10N016 501 2	145	C146 10N024 508 2	157
C146 10G032 500 4	128	C146 10N010 509 1	141	C146 10N016 502 1	147	C146 10N024 509 2	157
C146 10G032 501 4	128	C146 10N010 509 2	141	C146 10N016 502 2	147	C146 10N024 600 1	153
C146 10G032 600 4	128	C146 10N010 600 1	137	C146 10N016 503 2	147	C146 10N024 600 2	153
C146 10G032 601 4	128	C146 10N010 600 2	137	C146 10N016 504 1	149	C146 10N024 600 3	165
C146 10G048 506 1	160	C146 10N010 601 1	137	C146 10N016 504 2	149	C146 10N024 601 2	153
C146 10G048 507 1	160	C146 10N010 601 2	137	C146 10N016 505 2	149	C146 10N024 602 1	155
C146 10G048 508 1	160	C146 10N010 602 1	139	C146 10N016 506 1	147	C146 10N024 602 2	155
C146 10G048 606 1	160	C146 10N010 602 2	139	C146 10N016 506 2	147	C146 10N024 603 2	155
C146 10G048 607 1	160	C146 10N010 603 1	139	C146 10N016 507 2	147	C146 10N024 604 1	157
C146 10G048 608 1	160	C146 10N010 603 2	139	C146 10N016 600 1	145	C146 10N024 604 2	157
C146 10N003 500 4	117	C146 10N010 604 1	141	C146 10N016 600 2	145	C146 10N024 605 2	157
C146 10N006 502 1	135	C146 10N010 604 2	141	C146 10N016 601 2	145	C146 10N024 606 1	155
C146 10N006 502 2	135	C146 10N010 605 1	141	C146 10N016 602 1	147	C146 10N024 606 2	155
C146 10N006 503 1	135	C146 10N010 605 2	141	C146 10N016 602 2	147	C146 10N024 607 2	155
C146 10N006 503 2	135	C146 10N010 606 1	139	C146 10N016 603 2	147	C146 10N024 608 1	157
C146 10N006 506 1	135	C146 10N010 606 2	139	C146 10N016 604 1	149	C146 10N024 608 2	157
C146 10N006 506 2	135	C146 10N010 607 1	139	C146 10N016 604 2	149	C146 10N024 609 2	157
C146 10N006 507 1	135	C146 10N010 607 2	139	C146 10N016 605 2	149	C146 10N024 700 1	153
C146 10N006 507 2	135	C146 10N010 608 1	141	C146 10N016 606 1	147	C146 10N024 700 2	153
C146 10N006 602 1	135	C146 10N010 608 2	141	C146 10N016 606 2	147	C146 10N024 701 2	153
C146 10N006 602 2	135	C146 10N010 609 1	141	C146 10N016 607 2	147	C146 10N024 702 1	155
C146 10N006 603 1	135	C146 10N010 609 2	141	C146 10N016 700 1	145	C146 10N024 702 2	155
C146 10N006 603 2	135	C146 10N010 700 1	137	C146 10N016 700 2	145	C146 10N024 703 2	155
C146 10N006 606 1	135	C146 10N010 701 1	137	C146 10N016 701 2	145	C146 10N024 708 1	155
C146 10N006 606 2	135	C146 10N010 702 1	139	C146 10N016 702 1	147	C146 10N024 708 2	155
C146 10N006 607 1	135	C146 10N010 703 1	139	C146 10N016 702 2	147	C146 10N024 709 2	155
C146 10N006 607 2	135	C146 10N010 708 1	139	C146 10N016 703 2	147	C146 10N024 802 1	155
C146 10N006 702 1	135	C146 10N010 709 1	139	C146 10N016 708 1	147	C146 10N024 802 2	155
C146 10N006 703 1	135	C146 10N010 802 1	139	C146 10N016 708 2	147	C146 10N024 803 2	155
C146 10N006 708 1	135	C146 10N010 802 2	139	C146 10N016 709 2	147	C146 10N024 804 1	157

Bestell Nr. / Part No.	Seite / Page	Bestell Nr. / Part No.	Seite / Page	Bestell Nr. / Part No.	Seite / Page	Bestell Nr. / Part No.	Seite / Page
C146 10N024 804 2	157	C146 10R010 552 8	141	C146 10R016 556 1	147	C146 10R024 606 1	155
C146 10N024 805 2	157	C146 10R010 556 1	139	C146 10R016 556 8	147	C146 10R024 606 8	155
C146 10N024 806 1	155	C146 10R010 556 8	139	C146 10R016 600 1	145	C146 10R024 607 8	155
C146 10N024 806 2	155	C146 10R010 600 1	137	C146 10R016 600 4	125	C146 10R024 650 1	153
C146 10N024 807 2	155	C146 10R010 600 4	121	C146 10R016 600 8	145	C146 10R024 650 3	165
C146 10N024 808 1	157	C146 10R010 600 8	137	C146 10R016 601 8	145	C146 10R024 650 8	153
C146 10N024 808 2	157	C146 10R010 601 8	137	C146 10R016 602 1	149	C146 10R024 652 1	157
C146 10N024 809 2	157	C146 10R010 602 1	141	C146 10R016 602 8	149	C146 10R024 652 8	157
C146 10N025 500 2	127	C146 10R010 602 8	141	C146 10R016 603 8	149	C146 10R024 656 1	155
C146 10N025 501 2	127	C146 10R010 603 8	141	C146 10R016 606 1	147	C146 10R024 656 8	155
C146 10N025 600 2	127	C146 10R010 606 1	139	C146 10R016 606 8	147	C146 10R024 802 1	153
C146 10N025 601 2	127	C146 10R010 606 8	139	C146 10R016 607 8	147	C146 10R024 802 3	165
C146 10N025 606 2	127	C146 10R010 607 1	139	C146 10R016 650 1	145	C146 10R024 802 8	153
C146 10N025 607 2	127	C146 10R010 607 8	139	C146 10R016 650 4	125	C146 10R024 803 8	153
C146 10N025 702 2	127	C146 10R010 650 1	137	C146 10R016 650 8	145	C146 10R024 804 1	155
C146 10N025 703 2	127	C146 10R010 650 4	121	C146 10R016 652 1	149	C146 10R024 804 8	155
C146 10N025 708 2	127	C146 10R010 650 8	137	C146 10R016 652 8	149	C146 10R024 805 8	155
C146 10N025 709 2	127	C146 10R010 652 1	141	C146 10R016 656 1	147	C146 10R024 852 1	153
C146 10N025 806 2	127	C146 10R010 652 8	141	C146 10R016 656 8	147	C146 10R024 852 3	165
C146 10N025 807 2	127	C146 10R010 656 1	139	C146 10R016 802 1	145	C146 10R024 852 8	153
C146 10N032 500 4	131	C146 10R010 656 8	139	C146 10R016 802 8	145	C146 10R024 854 1	155
C146 10N032 501 4	131	C146 10R010 802 1	137	C146 10R016 803 8	145	C146 10R024 854 8	155
C146 10N032 550 4	131	C146 10R010 802 8	137	C146 10R016 804 1	147	C146 10R024 903 8	159
C146 10N032 600 4	131	C146 10R010 803 1	137	C146 10R016 804 4	125	C146 10R024 908 8	159
C146 10N032 601 4	131	C146 10R010 803 8	137	C146 10R016 804 8	147	C146 10R024 909 8	159
C146 10N032 650 4	131	C146 10R010 804 1	139	C146 10R016 805 8	147	C146 10R025 500 2	125
C146 10N048 802 1	163	C146 10R010 804 4	121	C146 10R016 852 1	145	C146 10R025 550 2	125
C146 10N048 803 1	163	C146 10R010 804 8	139	C146 10R016 852 8	145	C146 10R025 600 2	125
C146 10N048 806 1	163	C146 10R010 805 1	139	C146 10R016 854 1	147	C146 10R025 650 2	125
C146 10N048 807 1	163	C146 10R010 805 8	139	C146 10R016 854 4	125	C146 10R025 804 2	125
C146 10R003 500 4	117	C146 10R010 852 1	137	C146 10R016 854 8	147	C146 10R025 854 2	125
C146 10R003 600 4	117	C146 10R010 852 8	137	C146 10R016 902 8	151	C146 10Z000 002 8	84
C146 10R003 804 4	117	C146 10R010 854 1	139	C146 10R016 910 8	151	C146 10Z001 001 8	84
C146 10R006 506 1	133	C146 10R010 854 4	121	C146 10R024 500 1	153	C146 10Z002 001 8	84
C146 10R006 506 8	133	C146 10R010 854 8	139	C146 10R024 500 3	165	C146 10Z003 100 4	116-117
C146 10R006 507 1	133	C146 10R010 902 8	143	C146 10R024 500 8	153	C146 10Z006 100 1	134-135
C146 10R006 556 8	133	C146 10R015 500 2	121	C146 10R024 501 8	153	C146 10Z006 200 1	134-135
C146 10R006 606 1	133	C146 10R015 550 2	121	C146 10R024 502 1	157	C146 10Z010 100 1	142-143
C146 10R006 606 8	133	C146 10R015 600 2	121	C146 10R024 502 8	157	C146 10Z010 200 1	142-143
C146 10R006 607 1	133	C146 10R015 650 2	121	C146 10R024 503 8	157	C146 10Z015 100 2	122-123
C146 10R006 656 1	133	C146 10R015 804 2	121	C146 10R024 506 1	155	C146 10Z016 100 1	150-151
C146 10R006 656 8	133	C146 10R015 854 2	121	C146 10R024 506 8	155	C146 10Z016 200 1	150-151
C146 10R006 804 1	133	C146 10R016 500 1	145	C146 10R024 507 8	155	C146 10Z024 100 1	158-159
C146 10R006 804 8	133	C146 10R016 500 4	125	C146 10R024 550 1	153	C146 10Z024 200 1	158-159
C146 10R006 805 1	133	C146 10R016 500 8	145	C146 10R024 550 3	165	C146 10Z025 100 2	126-127
C146 10R006 854 8	133	C146 10R016 501 8	145	C146 10R024 550 8	153	C146 11F006 001 8	170-171
C146 10R010 500 1	137	C146 10R016 502 1	149	C146 10R024 552 1	157	C146 11F006 901 8	170-171
C146 10R010 500 4	121	C146 10R016 502 8	149	C146 10R024 552 8	157	C146 11F006 902 8	170-171
C146 10R010 500 8	137	C146 10R016 503 8	149	C146 10R024 556 1	155	C146 11F010 000 8	172-173
C146 10R010 502 1	141	C146 10R016 506 1	147	C146 10R024 556 8	155	C146 11F010 901 8	172-173
C146 10R010 502 8	141	C146 10R016 506 8	147	C146 10R024 600 1	153	C146 11F010 902 8	172-173
C146 10R010 506 1	139	C146 10R016 507 8	147	C146 10R024 600 3	165	C146 11F016 000 8	174-175
C146 10R010 506 8	139	C146 10R016 550 1	145	C146 10R024 600 8	153	C146 11F016 901 8	174-175
C146 10R010 550 1	137	C146 10R016 550 4	125	C146 10R024 601 8	153	C146 11F016 902 8	174-175
C146 10R010 550 4	121	C146 10R016 550 8	145	C146 10R024 602 1	157	C146 11F024 000 8	176-177
C146 10R010 550 8	137	C146 10R016 552 1	149	C146 10R024 602 8	157	C146 11F024 901 8	176-177
C146 10R010 552 1	141	C146 10R016 552 8	149	C146 10R024 603 8	157	C146 11F024 902 8	176-177

Bestell Nr. / Part No.	Seite / Page	Bestell Nr. / Part No.	Seite / Page	Bestell Nr. / Part No.	Seite / Page	Bestell Nr. / Part No.	Seite / Page
C146 11G006 506 1	170	C146 11R016 600 1	175	C146 21R006 506 1	133	C146 21R010 854 4	121
C146 11G006 506 8	170	C146 11R016 600 8	175	C146 21R006 506 8	133	C146 21R010 854 8	139
C146 11G006 507 1	170	C146 11R016 601 8	175	C146 21R006 507 1	133	C146 21R010 902 8	81
C146 11G006 507 8	170	C146 11R016 650 1	175	C146 21R006 556 8	133	C146 21R015 500 2	121
C146 11G006 556 1	170	C146 11R016 650 8	175	C146 21R006 606 1	133	C146 21R015 550 2	121
C146 11G006 606 1	170	C146 11R024 500 1	177	C146 21R006 606 8	133	C146 21R015 600 2	121
C146 11G006 606 8	170	C146 11R024 500 8	177	C146 21R006 607 1	133	C146 21R015 650 2	121
C146 11G006 607 1	170	C146 11R024 501 8	177	C146 21R006 656 1	133	C146 21R015 804 2	121
C146 11G006 607 8	170	C146 11R024 550 1	177	C146 21R006 656 8	133	C146 21R015 854 2	121
C146 11G010 500 1	172	C146 11R024 550 8	177	C146 21R006 804 1	133	C146 21R016 500 1	145, 151
C146 11G010 500 8	172	C146 11R024 600 1	177	C146 21R006 804 8	133	C146 21R016 500 4	125
C146 11G010 501 1	172	C146 11R024 600 8	177	C146 21R006 805 1	133	C146 21R016 500 8	145, 151
C146 11G010 501 8	172	C146 11R024 601 8	177	C146 21R006 854 8	133	C146 21R016 501 8	145, 151
C146 11G010 600 1	172	C146 11R024 650 1	177	C146 21R010 500 1	137, 143	C146 21R016 502 1	149
C146 11G010 600 8	172	C146 11R024 650 8	177	C146 21R010 500 4	121	C146 21R016 502 8	149
C146 11G010 601 1	172	C146 12A006 102 1	51	C146 21R010 500 8	137, 143	C146 21R016 503 8	149
C146 11G010 601 8	172	C146 12A006 152 1	51	C146 21R010 502 1	141	C146 21R016 506 1	147
C146 11G016 500 1	174	C146 12A010 102 1	51	C146 21R010 502 8	141	C146 21R016 506 8	147
C146 11G016 500 8	174	C146 12A010 152 1	51	C146 21R010 506 1	139	C146 21R016 507 8	147
C146 11G016 501 1	174	C146 12A016 102 1	51	C146 21R010 506 8	139	C146 21R016 550 1	145, 151
C146 11G016 501 8	174	C146 12A016 152 1	51	C146 21R010 550 1	137, 143	C146 21R016 550 4	125
C146 11G016 600 1	174	C146 12A024 102 1	51	C146 21R010 550 4	121	C146 21R016 550 8	145, 151
C146 11G016 600 8	174	C146 12A024 152 1	51	C146 21R010 550 8	137, 143	C146 21R016 552 1	149
C146 11G016 601 1	174	C146 12A040 102 2	52	C146 21R010 552 1	141	C146 21R016 552 8	149
C146 11G016 601 8	174	C146 12A040 152 2	52	C146 21R010 552 8	141	C146 21R016 556 1	147
C146 11G024 500 1	176	C146 12A064 102 2	52	C146 21R010 556 1	139	C146 21R016 556 8	147
C146 11G024 500 8	176	C146 12A064 152 2	52	C146 21R010 556 8	139	C146 21R016 600 1	145, 151
C146 11G024 501 1	176	C146 12B006 102 1	51	C146 21R010 600 1	137, 143	C146 21R016 600 4	125
C146 11G024 501 8	176	C146 12B006 152 1	51	C146 21R010 600 4	121	C146 21R016 600 8	145, 151
C146 11G024 600 1	176	C146 12B010 102 1	51	C146 21R010 600 8	137, 143	C146 21R016 601 8	145, 151
C146 11G024 600 8	176	C146 12B010 152 1	51	C146 21R010 601 8	137, 143	C146 21R016 602 1	149
C146 11G024 601 1	176	C146 12B016 102 1	51	C146 21R010 602 1	141	C146 21R016 602 8	149
C146 11G024 601 8	176	C146 12B016 152 1	51	C146 21R010 602 8	141	C146 21R016 603 8	149
C146 11R006 506 1	171	C146 12B024 102 1	51	C146 21R010 603 8	141	C146 21R016 606 1	147
C146 11R006 506 8	171	C146 12B024 152 1	51	C146 21R010 606 1	139	C146 21R016 606 8	147
C146 11R006 507 1	171	C146 12B040 102 2	52	C146 21R010 606 8	139	C146 21R016 607 8	147
C146 11R006 556 1	171	C146 12B040 152 2	52	C146 21R010 607 1	139	C146 21R016 650 1	145, 151
C146 11R006 556 8	171	C146 12B064 102 2	52	C146 21R010 607 8	139	C146 21R016 650 4	125
C146 11R006 606 1	171	C146 12B064 152 2	52	C146 21R010 650 1	137, 143	C146 21R016 650 8	145, 151
C146 11R006 606 8	171	C146 16F003 000 4	117	C146 21R010 650 4	121	C146 21R016 652 1	149
C146 11R006 607 1	171	C146 16N003 500 4	117	C146 21R010 650 8	137, 143	C146 21R016 652 8	149
C146 11R006 656 8	171	C146 16R003 500 4	117	C146 21R010 652 1	141	C146 21R016 656 1	147
C146 11R010 500 1	173	C146 16R003 600 4	117	C146 21R010 652 8	141	C146 21R016 656 8	147
C146 11R010 500 8	173	C146 21G006 501 1	134	C146 21R010 656 1	139	C146 21R016 802 1	145
C146 11R010 550 1	173	C146 21G006 506 8	134	C146 21R010 656 8	139	C146 21R016 802 8	145
C146 11R010 550 8	173	C146 21G010 500 1	142	C146 21R010 802 1	137	C146 21R016 803 8	145
C146 11R010 600 1	173	C146 21G010 500 8	142	C146 21R010 802 8	137	C146 21R016 804 1	147
C146 11R010 600 8	173	C146 21G010 600 1	142	C146 21R010 803 1	137	C146 21R016 804 4	125
C146 11R010 601 1	173	C146 21G010 600 8	142	C146 21R010 803 8	137	C146 21R016 804 8	147
C146 11R010 601 8	173	C146 21G016 500 1	150	C146 21R010 804 1	139	C146 21R016 805 8	147
C146 11R010 650 1	173	C146 21G016 501 8	150	C146 21R010 804 4	121	C146 21R016 852 1	145
C146 11R010 650 8	173	C146 21G016 600 1	150	C146 21R010 804 8	139	C146 21R016 852 8	145
C146 11R016 500 1	175	C146 21G016 601 8	150	C146 21R010 805 1	139	C146 21R016 854 1	147
C146 11R016 500 8	175	C146 21G024 500 1	158	C146 21R010 805 8	139	C146 21R016 854 4	125
C146 11R016 501 8	175	C146 21G024 501 8	158	C146 21R010 852 1	137	C146 21R016 854 8	147
C146 11R016 550 1	175	C146 21G024 600 1	158	C146 21R010 852 8	137	C146 21R016 910 8	81
C146 11R016 550 8	175	C146 21G024 601 8	158	C146 21R010 854 1	139	C146 21R024 500 1	153, 159

Bestell Nr. / Part No.	Seite / Page	Bestell Nr. / Part No.	Seite / Page	Bestell Nr. / Part No.	Seite / Page	Bestell Nr. / Part No.	Seite / Page
C146 21R024 500 8	153, 159	C146 21R032 652 4	129	C146 N32 015 G1	186	HN01 025 0001 (1)	35, 37, 39, 41, 43, 75
C146 21R024 501 8	153, 159	C146 21R032 802 4	129	C146 N32 015 G2	186	HN01 025 0007 (1)	111
C146 21R024 502 1	157	C146 21R032 803 4	129	C146 N32 025 G1	186	HN01 025 0008 (1)	111
C146 21R024 502 8	157	C146 21R032 852 4	129	C146 N32 025 G2	186	HN01 025 0010 (1)	35, 37, 39, 41, 43, 75
C146 21R024 503 8	157	C146 21R048 506 1	161	C146 N32 037 G1	186	HN02 016 0002 (1)	11, 13, 15, 17, 19, 21, 23, 67
C146 21R024 506 1	155	C146 21R048 507 1	161	C146 N32 050 G1	186	HN02 016 0002 (2)	11, 13, 15, 17, 19, 21, 23, 67
C146 21R024 506 8	155	C146 21R048 508 1	161	C146 N33 009 G1	186	HN02 016 0003 (1)	11, 13, 15, 17, 19, 21, 23, 67
C146 21R024 507 8	155	C146 21R048 606 1	161	C146 N33 015 G1	186	HN02 016 0003 (2)	11, 13, 15, 17, 19, 21, 23, 67
C146 21R024 550 1	153, 159	C146 21R048 607 1	161	C146 N33 025 G1	186	HN02 016 0005 (1)	11, 13, 15, 17, 19, 21, 23, 67
C146 21R024 550 8	153, 159	C146 21R048 608 1	161	C146 N33 037 G1	186	HN02 016 0005 (2)	11, 13, 15, 17, 19, 21, 23, 67
C146 21R024 552 1	157	C146 30F003 000 4	118-119	C146 N33 050 G1	186	HN02 016 0015 (1)	11, 13, 15, 17, 19, 21, 23, 67
C146 21R024 552 8	157	C146 30F003 004 4	118-119	C146 P06 001 G8	63	HN02 016 0016 (1)	11, 13, 15, 17, 19, 21, 23, 67
C146 21R024 556 1	155	C146 30F003 500 4	118	C146 P06 002 G8	63	HN02 025 0001 (1)	35, 37, 39, 41, 43, 75, 111
C146 21R024 556 8	155	C146 30G003 500 4	118	C146 P10 001 G8	63	HN02 025 0010 (1)	35, 37, 39, 41, 43, 75, 111
C146 21R024 600 1	153, 159	C146 30G003 600 4	118	C146 P10 002 G8	63	N01 016 0040 8	189
C146 21R024 600 8	153, 159	C146 30G003 804 4	118	C146 P16 001 G8	63	N02 016 0040 8	189
C146 21R024 601 8	153, 159	C146 30N003 500 4	119	C146 P16 002 G8	63	T 1860 000	112
C146 21R024 602 1	157	C146 30R003 500 4	119	C146 P24 001 G8	63	T 1860 010	112
C146 21R024 602 8	157	C146 30R003 600 4	119	C146 P24 002 G8	63	T 1860 021	112
C146 21R024 603 8	157	C146 30R003 804 4	119	C146 P24 101 G8	63	T 1860 022	112
C146 21R024 606 1	155	C146 30Z003 100 4	118-119	C146 P24 102 G8	63	T 1861 002	112
C146 21R024 606 8	155	C146 31N003 500 4	119	C146 S06 001 G8	63	T 1861 012	112
C146 21R024 607 8	155	C146 A00 001 E8	84	C146 S06 002 G8	63	T 1862 001	112
C146 21R024 650 1	153, 159	C146 A03 001 E8	62, 73	C146 S10 001 G8	63	TA 0000	24, 44, 67, 69, 71, 73, 75, 77, 79
C146 21R024 650 8	153, 159	C146 A03 001 E8	62, 73	C146 S10 002 G8	63	TA 0000 121	75
C146 21R024 652 1	157	C146 A03 501 E8	62, 77	C146 S16 001 G8	63	TA 0000 124	71, 73, 79
C146 21R024 652 8	157	C146 A03 801 E8	62, 79	C146 S16 002 G8	63	TA 0000 141	24, 44, 67, 75
C146 21R024 656 1	155	C146 A05 001 E8	62, 71	C146 S24 001 G8	63	TA 0000 144	71, 73, 79
C146 21R024 656 8	155	C146 A10 001 E8	62, 69	C146 S24 002 G8	63	TA 0000 163	24, 44, 67, 75
C146 21R024 802 1	153	C146 A20 001 G8	62, 65	C146 S24 101 G8	63	TA 0000 180	73, 79
C146 21R024 802 8	153	C146 B00 001 E8	84	C146 S24 102 G8	63	TA 0000 184	69
C146 21R024 803 8	153	C146 B03 001 E8	62, 73	FG 0200 146 1	44, 75, 84	TA 0000 202	24, 67
C146 21R024 804 1	155	C146 B03 501 E8	62, 77	FG 0300 146 1	24, 67, 69, 84	TA 0000 401	77
C146 21R024 804 8	155	C146 B03 801 E8	62, 79	FG 0300 146 3	73, 77, 79, 84	TA 0000 402	77
C146 21R024 805 8	155	C146 B05 001 E8	62, 71	FG 0300 146 4	71, 84	TA 0001 146 000 1	24, 67
C146 21R024 852 1	153	C146 B10 001 E8	62, 69	FG 1000 146	65, 67, 69, 71, 73, 75, 77, 79, 84	TA 0002 146 000 1	24, 67
C146 21R024 852 8	153	C146 B20 001 G8	62, 65	FN01 010 0130 (2)	65	TA 0003 146 000 1	75
C146 21R024 854 1	155	C146 C04 001 E8	62, 75	FN01 010 0131 (2)	65	TA 0004 146 000 1	44, 75
C146 21R024 854 8	155	C146 C05 001 E8	62, 75	FN02 010 0130 (2)	65	TA 0005 146 000 3	44, 75
C146 21R024 913 8	81	C146 C05 801 E8	62, 75	FN02 010 0131 (2)	65	TA 0007 146 000 3	24, 67
C146 21R025 500 2	125	C146 C10 001 G8	62, 67	HN01 016 0002 (1)	11, 13, 15, 17, 19, 21, 23, 67	TA 0010 146 000 1	69
C146 21R025 550 2	125	C146 D04 001 E8	62, 75	HN01 016 0002 (2)	11, 13, 15, 17, 19, 21, 23, 67	TA 0010 146 000 2	71, 79
C146 21R025 600 2	125	C146 D05 001 E8	62, 75	HN01 016 0003 (1)	11, 13, 15, 17, 19, 21, 23, 67	TA 0010 146 000 3	71
C146 21R025 650 2	125	C146 D05 801 E8	62, 75	HN01 016 0003 (2)	11, 13, 15, 17, 19, 21, 23, 67	TA 0010 146 000 4	73, 79
C146 21R025 804 2	125	C146 D10 001 E8	62, 67	FN01 010 0130 (2)	65		
C146 21R025 854 2	125	C146 E12 001 E8	63, 81	FN01 010 0131 (2)	65		
C146 21R032 500 4	129	C146 F12 001 G8	63, 81	FN02 010 0130 (2)	65		
C146 21R032 501 4	129	C146 G01 014 G8	63, 83	FN02 010 0131 (2)	65		
C146 21R032 502 4	129	C146 G01 024 G8	63, 83	HN01 016 0002 (1)	11, 13, 15, 17, 19, 21, 23, 67		
C146 21R032 503 4	129	C146 G02 014 G8	63, 83	HN01 016 0002 (2)	11, 13, 15, 17, 19, 21, 23, 67		
C146 21R032 550 4	129	C146 G02 024 G8	63, 83	HN01 016 0003 (1)	11, 13, 15, 17, 19, 21, 23, 67		
C146 21R032 552 4	129	C146 H01 034 G8	63, 83	HN01 016 0003 (2)	11, 13, 15, 17, 19, 21, 23, 67		
C146 21R032 600 4	129	C146 H01 044 G8	63, 83	HN01 016 0005 (1)	11, 13, 15, 17, 19, 21, 23, 67		
C146 21R032 601 4	129	C146 H02 034 G8	63, 83	HN01 016 0005 (2)	11, 13, 15, 17, 19, 21, 23, 67		
C146 21R032 602 4	129	C146 H02 044 G8	63, 83	HN01 016 0015 (1)	11, 13, 15, 17, 19, 21, 23, 67		
C146 21R032 603 4	129	C146 N21 040 E1 X	51-52	HN01 016 0016 (1)	11, 13, 15, 17, 19, 21, 23, 67		
C146 21R032 650 4	129	C146 N32 009 G1	186				

Betellnummern Verzeichnis
Summary of Part Numbers

Bestell Nr. / Part No.	Seite / Page	Bestell Nr. / Part No.	Seite / Page	Bestell Nr. / Part No.	Seite / Page	Bestell Nr. / Part No.	Seite / Page
TA 0010 146 000 5	73	VN01 016 0002 (1)	11, 13, 15, 17, 19, 21, 23, 67	VN01 025 0035 (1)C	35, 37, 39, 41, 43, 47, 188		17, 19, 21, 23, 27, 69, 188
TA 0100 146	24, 67	VN01 016 0002 (2)	11, 13, 15, 17, 19, 21, 23, 67	VN01 025 0035 (2)C	35, 37, 39, 41, 43, 47	VN02 016 0027 (2)C	11, 13, 15, 17, 19, 21, 23, 27, 69
TA 0200 146	65	VN01 016 0003 (1)	11, 13, 15, 17, 19, 21, 23, 67	VN01 025 0036 (1)C	35, 37, 39, 41, 43, 47, 188	VN02 016 0028 (1)C	11, 13, 15, 17, 19, 21, 23, 27, 69, 188
TA 0500	24	VN01 016 0003 (2)	11, 13, 15, 17, 19, 21, 23, 67	VN01 025 0036 (2)C	35, 37, 39, 41, 43, 47	VN02 016 0028 (2)C	11, 13, 15, 17, 19, 21, 23, 27, 69
TB 0200 146	73, 79	VN01 016 0005 (1)	11, 13, 15, 17, 19, 21, 23, 67	VN01 025 0037 (1)C	35, 37, 39, 41, 43, 47, 188	VN02 016 0040 (8) X	69
TB 0500 146	69	VN01 016 0005 (2)	11, 13, 15, 17, 19, 21, 23, 67	VN01 025 0037 (2)C	35, 37, 39, 41, 43, 47	VN02 025 0001 (101)	35, 37, 39, 41, 43, 75, 111
TB 0600 146	44	VN01 016 0015 (1)	11, 13, 15, 17, 19, 21, 23, 67	VN01 025 0037 (2)C	35, 37, 39, 41, 43, 47	VN02 025 0001 (102)	35, 37, 39, 41, 43, 75
TN01 010 0130 (2)	65	VN01 016 0016 (1)	11, 13, 15, 17, 19, 21, 23, 67	VN01 025 0038 (1)C	35, 37, 39, 41, 43, 47, 188	VN02 025 0010 (101)	35, 37, 39, 41, 43, 75, 111
TN01 010 0131 (2)	65	VN01 016 0024 (1)C	11, 13, 15, 17, 19, 21, 23, 27, 69, 188	VN01 025 0038 (2)C	35, 37, 39, 41, 43, 47	VN02 025 0010 (102)	35, 37, 39, 41, 43, 75
TN01 016 0002 (1)	11, 13, 15, 17, 19, 21, 23, 67	VN01 016 0024 (2)C	11, 13, 15, 17, 19, 21, 23, 27, 69	VN01 025 0039 (1)C	35, 37, 39, 41, 43, 47, 188	VN02 025 0029 (1)C	71, 188
TN01 016 0003 (1)	11, 13, 15, 17, 19, 21, 23, 67	VN01 016 0025 (1)C	11, 13, 15, 17, 19, 21, 23, 27, 69, 188	VN01 025 0039 (2)C	35, 37, 39, 41, 43, 47	VN02 025 0029 (2)C	71
TN01 016 0003 (2)	11, 13, 15, 17, 19, 21, 23, 67	VN01 016 0025 (2)C	11, 13, 15, 17, 19, 21, 23, 27, 69	VN01 025 0043 (1)	75	VN02 025 0030 (1)C	71, 188
TN01 016 0005 (1)	11, 13, 15, 17, 19, 21, 23, 67	VN01 016 0026 (1)C	11, 13, 15, 17, 19, 21, 23, 27, 69, 188	VN01 036 0001 (1)C	73, 79, 188	VN02 025 0030 (2)C	71
TN01 016 0005 (2)	11, 13, 15, 17, 19, 21, 23, 67	VN01 016 0026 (2)C	11, 13, 15, 17, 19, 21, 23, 27, 69, 188	VN01 036 0002 (1)C	73, 79, 188	VN02 025 0031 (1)C	71, 188
TN01 016 0015 (1)	11, 13, 15, 17, 19, 21, 23, 67	VN01 016 0027 (1)C	11, 13, 15, 17, 19, 21, 23, 27, 69, 188	VN01 036 0003 (1)C	73, 79, 188	VN02 025 0031 (2)C	71
TN01 016 0016 (1)	11, 13, 15, 17, 19, 21, 23, 67	VN01 016 0027 (2)C	11, 13, 15, 17, 19, 21, 23, 27, 69	VN01 036 0004 (1)C	73, 79, 188	VN02 025 0032 (1)C	71, 188
TN01 025 0001 (1)	35, 37, 39, 41, 43, 75	VN01 016 0028 (1)C	11, 13, 15, 17, 19, 21, 23, 27, 69, 188	VN01 036 0005 (1)C	73, 79, 188	VN02 025 0032 (2)C	71
TN01 025 0007 (1)	111	VN01 016 0028 (2)C	11, 13, 15, 17, 19, 21, 23, 27, 69	VN02 010 0130 (2)	65	VN02 025 0033 (1)C	71, 188
TN01 025 0008 (1)	111	VN01 016 0028 (2)C	11, 13, 15, 17, 19, 21, 23, 27, 69, 188	VN02 010 0131 (2)	65	VN02 025 0033 (2)C	71
TN01 025 0010 (1)	35, 37, 39, 41, 43, 75	VN01 016 0029 (1)C	11, 13, 15, 17, 19, 21, 23, 27, 69, 188	VN02 016 0002 (1)	11, 13, 15, 17, 19, 21, 23, 67	VN02 025 0035 (1)C	35, 37, 39, 41, 43, 47, 188
TN01 025 0043 (1)	75	VN01 016 0029 (2)C	11, 13, 15, 17, 19, 21, 23, 27, 69	VN02 016 0002 (2)	11, 13, 15, 17, 19, 21, 23, 67	VN02 025 0035 (2)C	35, 37, 39, 41, 43, 47
TN02 010 0130 (2)	65	VN01 016 0030 (1)C	11, 13, 15, 17, 19, 21, 23, 27, 69, 188	VN02 016 0003 (1)	11, 13, 15, 17, 19, 21, 23, 67	VN02 025 0036 (1)C	35, 37, 39, 41, 43, 47, 188
TN02 010 0131 (2)	65	VN01 016 0030 (2)C	11, 13, 15, 17, 19, 21, 23, 27, 69, 188	VN02 016 0003 (2)	11, 13, 15, 17, 19, 21, 23, 67	VN02 025 0036 (2)C	35, 37, 39, 41, 43, 47
TN02 016 0002 (1)	11, 13, 15, 17, 19, 21, 23, 67	VN01 016 0040 (8) X	69	VN02 016 0003 (2)	11, 13, 15, 17, 19, 21, 23, 67	VN02 025 0037 (1)C	35, 37, 39, 41, 43, 47, 188
TN02 016 0002 (2)	11, 13, 15, 17, 19, 21, 23, 67	VN01 025 0001 (101)	35, 37, 39, 41, 43, 75	VN02 016 0005 (1)	11, 13, 15, 17, 19, 21, 23, 67	VN02 025 0037 (2)C	35, 37, 39, 41, 43, 47
TN02 016 0003 (1)	11, 13, 15, 17, 19, 21, 23, 67	VN01 025 0001 (102)	35, 37, 39, 41, 43, 75	VN02 016 0005 (2)	11, 13, 15, 17, 19, 21, 23, 67	VN02 025 0038 (1)C	35, 37, 39, 41, 43, 47, 188
TN02 016 0003 (2)	11, 13, 15, 17, 19, 21, 23, 67	VN01 025 0007 (101)	111	VN02 016 0015 (1)	11, 13, 15, 17, 19, 21, 23, 67	VN02 025 0038 (2)C	35, 37, 39, 41, 43, 47
TN02 016 0005 (1)	11, 13, 15, 17, 19, 21, 23, 67	VN01 025 0008 (101)	111	VN02 016 0016 (1)	11, 13, 15, 17, 19, 21, 23, 67	VN02 025 0039 (1)C	35, 37, 39, 41, 43, 47, 188
TN02 016 0005 (2)	11, 13, 15, 17, 19, 21, 23, 67	VN01 025 0010 (101)	35, 37, 39, 41, 43, 75	VN02 016 0024 (1)C	11, 13, 15, 17, 19, 21, 23, 27, 69, 188	VN02 025 0039 (2)C	35, 37, 39, 41, 43, 47
TN02 016 0015 (1)	11, 13, 15, 17, 19, 21, 23, 67	VN01 025 0010 (102)	35, 37, 39, 41, 43, 75	VN02 016 0024 (2)C	11, 13, 15, 17, 19, 21, 23, 27, 69	VN02 025 0043 (1)	75
TN02 016 0016 (1)	11, 13, 15, 17, 19, 21, 23, 67	VN01 025 0029 (1)C	71, 188	VN02 016 0025 (1)C	11, 13, 15, 17, 19, 21, 23, 27, 69, 188	VN02 036 0001 (1)C	73, 79, 188
TN02 025 0001 (1)	35, 37, 39, 41, 43, 75, 111	VN01 025 0029 (2)C	71	VN02 016 0025 (2)C	11, 13, 15, 17, 19, 21, 23, 27, 69, 188	VN02 036 0002 (1)C	73, 79, 188
TN02 025 0010 (1)	35, 37, 39, 41, 43, 75, 111	VN01 025 0030 (1)C	71, 188	VN02 016 0025 (2)C	11, 13, 15, 17, 19, 21, 23, 27, 69	VN02 036 0003 (1)C	73, 79, 188
TN02 025 0043 (1)	75	VN01 025 0030 (2)C	71	VN02 016 0026 (1)C	11, 13, 15, 17, 19, 21, 23, 27, 69, 188	VN02 036 0004 (1)C	73, 79, 188
VN01 010 0130 (2)	65	VN01 025 0031 (1)C	71, 188	VN02 016 0026 (2)C	11, 13, 15, 17, 19, 21, 23, 27, 69, 188	VN02 036 0005 (1)C	73, 79, 188
VN01 010 0131 (2)	65	VN01 025 0031 (2)C	71	VN02 016 0026 (2)C	11, 13, 15, 17, 19, 21, 23, 27, 69, 188	VN03 030 0020	184
		VN01 025 0032 (1)C	71, 188	VN02 016 0027 (1)C	11, 13, 15, 17, 19, 21, 23, 27, 69, 188	VN03 030 0021	184
		VN01 025 0032 (2)C	71			VN03 030 3000 X	184
		VN01 025 0033 (1)C	71, 188			VN13 040 0008 (1) X	184
		VN01 025 0033 (2)C	71			VN13 040 0009 (1) X	184

Bestell Nr. / Part No.	Seite / Page	Bestell Nr. / Part No.	Seite / Page	Bestell Nr. / Part No.	Seite / Page	Bestell Nr. / Part No.	Seite / Page
VN16 020 0113 (1) X	182	VN16 290 0029 X	181		19, 21, 23, 67		
VN16 025 0113 (1) X	182	VN16 320 0102 V	181	ZN02 016 0015 (1)	11, 13, 15, 17,		
VN16 032 0113 (1) X	182	VN16 320 0103 V	181		19, 21, 23, 67		
VN16 040 0113 (1) X	182	VN16 320 0114 X	180	ZN02 016 0016 (1)	11, 13, 15, 17,		
VN16 110 0004 V	181	VN16 320 0126 X	183		19, 21, 23, 67		
VN16 110 0013 X	180	VN16 320 0127 X	182	ZN02 025 0001 (1)	35, 37, 39,		
VN16 110 0014 X	180	VN16 360 0013 X	180		41, 43, 75, 111		
VN16 110 0026 X	183	VN16 360 0014 X	180	ZN02 025 0001 (2)	35, 37, 39,		
VN16 110 0027 X	182	VN16 400 0114 X	180		41, 43, 75		
VN16 110 0028 X	181	VN16 400 0126 X	183	ZN02 025 0010 (1)	35, 37, 39,		
VN16 110 0029 X	181	VN16 400 0127 X	182		41, 43, 75, 111		
VN16 135 0002 V	181	VN16 420 0013 X	180	ZN02 025 0010 (2)	35, 37, 39,		
VN16 135 0003 V	181	VN16 420 0014 X	180		41, 43, 75		
VN16 135 0013 X	180	VN16 500 0114 X	180				
VN16 135 0014 X	180	VN17 050 0004 (1)	184				
VN16 135 0026 X	183	VN17 050 0004 (101)	184				
VN16 135 0027 X	182	ZN01 010 0130 (2)	65				
VN16 135 0028 X	181	ZN01 010 0131 (2)	65				
VN16 135 0029 X	181	ZN01 016 0002 (1)	11, 13, 15, 17,				
VN16 160 0002 V	181		19, 21, 23, 67				
VN16 160 0003 V	181	ZN01 016 0002 (2)	11, 13, 15, 17,				
VN16 160 0013 X	180		19, 21, 23, 67				
VN16 160 0014 X	180	ZN01 016 0003 (1)	11, 13, 15, 17,				
VN16 160 0026 X	183		19, 21, 23, 67				
VN16 160 0027 X	182	ZN01 016 0003 (2)	11, 13, 15, 17,				
VN16 160 0028 X	181		19, 21, 23, 67				
VN16 160 0029 X	181	ZN01 016 0005 (1)	11, 13, 15, 17,				
VN16 160 0102 V	181		19, 21, 23, 67				
VN16 160 0126 X	183	ZN01 016 0005 (2)	11, 13, 15, 17,				
VN16 160 0127 X	182		19, 21, 23, 67				
VN16 200 0102 V	181	ZN01 016 0015 (1)	11, 13, 15, 17,				
VN16 200 0103 V	181		19, 21, 23, 67				
VN16 200 0114 X	180	ZN01 016 0016 (1)	11, 13, 15, 17,				
VN16 200 0114 X	180		19, 21, 23, 67				
VN16 200 0126 X	183	ZN01 025 0001 (1)	35, 37, 39, 41,				
VN16 200 0127 X	182		43, 75				
VN16 210 0002 V	181	ZN01 025 0001 (2)	35, 37, 39, 41,				
VN16 210 0003 V	181		43, 75				
VN16 210 0013 X	180	ZN01 025 0007 (1)	111				
VN16 210 0014 X	180	ZN01 025 0008 (1)	111				
VN16 210 0026 X	183	ZN01 025 0010 (1)	35, 37, 39, 41,				
VN16 210 0027 X	182		43, 75				
VN16 210 0028 X	181	ZN01 025 0010 (2)	35, 37, 39, 41,				
VN16 210 0029 X	181		43, 75				
VN16 250 0102 V	181	ZN02 010 0130 (2)	65				
VN16 250 0103 V	181	ZN02 010 0131 (2)	65				
VN16 250 0114 X	180	ZN02 016 0002 (1)	11, 13, 15, 17,				
VN16 250 0126 X	183		19, 21, 23, 67				
VN16 250 0127 X	182	ZN02 016 0002 (2)	11, 13, 15, 17,				
VN16 250 0131 V	81		19, 21, 23, 67				
VN16 290 0002 V	181	ZN02 016 0003 (1)	11, 13, 15, 17,				
VN16 290 0003 V	181		19, 21, 23, 67				
VN16 290 0013 X	180	ZN02 016 0003 (2)	11, 13, 15, 17,				
VN16 290 0014 X	180		19, 21, 23, 67				
VN16 290 0026 X	183	ZN02 016 0005 (1)	11, 13, 15, 17,				
VN16 290 0027 X	182		19, 21, 23, 67				
VN16 290 0028 X	181	ZN02 016 0005 (2)	11, 13, 15, 17,				

International

Argentina

Amphenol Argentina
Av. Callao 930
2nd Floor Office B "Plaza"
C1023 AAP Buenos Aires
Phone +54 / 11 / 48 15 68 86
Fax +54 / 11 / 48 14 57 79

Australia

Amphenol Australia Ltd.
2 Fiveways Blvd
Keysborough
Victoria 31 73
Phone +61 / 3 / 8796 / 8888
Fax +61 / 3 / 8796 / 8801

Austria

Amphenol-Tuchel Austria
Lannerweg 14
A-4614 Marchtrenk
Phone +43 / 7243 / 52555
Fax +43 / 7243 / 53535

Belgium

Amphenol-Tuchel Belgium
Brusselbaan 524b
B 1600 Sint-Pieters-Leeuw
Phone +32 / 2377 / 2549
Fax +32 / 2377 / 5303

Brasilia

Amphenol do Brasil Ltda.
Rua Diogo Moreira 132, 20th Floor
CEP 05423-010 Sao Paulo SP
Phone +55 / 11 / 3815.1003
Fax +55 / 11 / 3815.1629

China

Amphenol-Tuchel Electronics GmbH
China Branch
210-1 Taishan Road
Changzhou 213022
Phone +86 / 05 19 / 5 11 03 01
Fax +86 / 05 19 / 5 11 02 99

France

Amphenol-Tuchel France
Bât. Le Newton C
7 Mail B. Thimonnier
77185 Lognes
Phone +33 / 164627676
Fax +33 / 164627677

Germany

Amphenol-Tuchel Electronics GmbH
August-Haeusser-Str. 10
74080 Heilbronn
Phone +49 / 7131 / 929-0
Fax +49 / 7131 / 929-486

Great Britain

Amphenol-Tuchel Great Britain
14 Plover Close
Kempshott, Basingstoke
Hants, RG22 5PQ
Phone +44 / 1256 / 330749
Fax +44 / 1256 / 330749

Hong Kong

Amphenol East Asia Limited
Units 2201-02, Railway Plaza
39 Chatham Road South
Tsimshatsui, Kowloon
Phone +852 / 2699 / 2663
Fax +852 / 2688 / 0974

India

Amphetronix Limited
Plot No. 105 Bhosari Industrial Area
Pune - 411 026
Phone +91 / 20 / 27 12 14 18
Fax +91 / 20 / 27 12 05 81

Italy

Amphenol-Tuchel Italy
Via Barbaiana n. 5
I-20020 Lainate (MI)
Phone. +39 / 2 / 932 541
Fax +39 / 2 / 932 5444

Japan

Amphenol Japan, K.K.
2-3-27, Kudan Minami
Chiyoda-Ku
Tokyo 102
Phone +81 / 3 / 32 63 / 56 11
Fax +81 / 3 / 52 76 / 70 59

Korea

Amphenol DaeShin Limited
#802 Joong-Dong 1131-5
Wonmi-Ku
Bucheon-City
Kyunggi-Do
Korea 420-020
Phone +82 / 2 / 785 / 1588
Fax +82 / 2 / 589 / 1514

Mexico

Amphenol Mexico
Prolongacion Reforma 61 - 6 B2
Col. Paseo de las Lomas
C.P. 01330 Mexico D.F.
Phone +52 / 55 / 5258.9984
Fax +52 / 55 / 5081.6890

Singapore

Amphenol East Asia Limited
Asia Pacific Sales Operation
Singapore Branch
300 Beach Road
#25-07 The Concourse
Singapore 199555
Phone +27 / 11 / 305-9574
Fax +27 / 11 / 305-9576

South Africa

Amphenol International Ltd
Chislehurst
30 Impala Road
Chislehurst
Sandton, 2146
Phone +27 / 11 / 7 83 95 17
Fax +27 / 11 / 7 83 95 19

Spain

Amphenol-Tuchel Spain
Ctra Sabadell a Mollet,
km 4.5 Nave 5
08130 Santa Perpetua de
Mogoda (Barcelona)
Phone +34/93/574.41.34
Fax +34/93/574.10.09

Sweden

Amphenol-Tuchel Scandinavia
P.O. Box 20
SE 195 42 Märsta
Phone +46 / 8 591 / 175 76
Fax +46 / 8 591 / 175 76

Taiwan

Amphenol East Asia Ltd.
Taiwan Branch (H.K.)
116 Zhong Shan Road
Lane 956 Taoyuan City
Taiwan R.O.C. 330
Phone +886 / 3 / 370 / 7855
Fax +886 / 3 / 360 7259

Turkey

Amphenol Türkiye
Ayazaga Mah. Meydan Sk. No. 28
Beybi Giz Plaza, Kat. 26
34396 Maslak/Istanbul
Phone +90 / 0212 / 335 25 01
Fax +90 / 0212 / 335 25 00

USA

Amphenol-Tuchel Electronics
6900 Haggerty Road
Suite 200
Canton, Michigan 48187
Phone +1 / 800 / 380 805
Phone +1 / 734 / 451 6400
Fax +1 / 734 / 451 7197

Amphenol Corporation
Corporate Headquarters
358 Hall Avenue
Wallingford, CT 06492
Phone +1 / 203 / 265 / 8900
Fax +1 / 203 / 265 / 8628

Ihr zuständiger Vertriebs- Ingenieur:
Your engineering sales representative:

Amphenol

Amphenol-Tuchel Electronics GmbH

August-Haeusser-Str. 10 · D-74080 Heilbronn · Germany · Phone +49(0)7131/929-0 · Fax +49(0)7131/929-486 · www.amphenol.info



Компания «ЭлектроПласт» предлагает заключение долгосрочных отношений при поставках импортных электронных компонентов на взаимовыгодных условиях!

Наши преимущества:

- Оперативные поставки широкого спектра электронных компонентов отечественного и импортного производства напрямую от производителей и с крупнейших мировых складов;
- Поставка более 17-ти миллионов наименований электронных компонентов;
- Поставка сложных, дефицитных, либо снятых с производства позиций;
- Оперативные сроки поставки под заказ (от 5 рабочих дней);
- Экспресс доставка в любую точку России;
- Техническая поддержка проекта, помощь в подборе аналогов, поставка прототипов;
- Система менеджмента качества сертифицирована по Международному стандарту ISO 9001;
- Лицензия ФСБ на осуществление работ с использованием сведений, составляющих государственную тайну;
- Поставка специализированных компонентов (Xilinx, Altera, Analog Devices, Intersil, Interpoint, Microsemi, Aeroflex, Peregrine, Syfer, Eurofarad, Texas Instrument, Miteq, Cobham, E2V, MA-COM, Hittite, Mini-Circuits, General Dynamics и др.);

Помимо этого, одним из направлений компании «ЭлектроПласт» является направление «Источники питания». Мы предлагаем Вам помощь Конструкторского отдела:

- Подбор оптимального решения, техническое обоснование при выборе компонента;
- Подбор аналогов;
- Консультации по применению компонента;
- Поставка образцов и прототипов;
- Техническая поддержка проекта;
- Защита от снятия компонента с производства.



Как с нами связаться

Телефон: 8 (812) 309 58 32 (многоканальный)

Факс: 8 (812) 320-02-42

Электронная почта: org@eplast1.ru

Адрес: 198099, г. Санкт-Петербург, ул. Калинина, дом 2, корпус 4, литера А.