

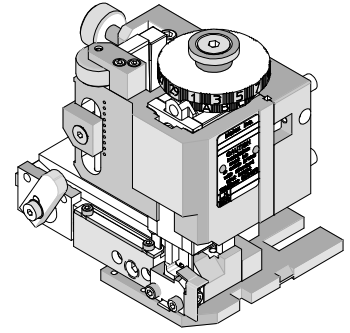

FineAdjust Applicator Specification Sheet Order No. 63900-5200



FEATURES

- Quick punch removal with the push of a button for fast and easy tooling change
- Applicator designed to industry standard mounting and shut height 135.80mm (5.346")
- Quick set-up time; plus the crimp height, track and feed adjustments can be set without removing the applicator from the press
- Fine adjustment allows users to achieve target with little effort by adjusting in increments of 0.015mm (.0006") for conductor crimp height and .063mm (.0025") for insulation height
- Independent adjustment rings allow users to quickly adjust the conductor or insulation crimp height without affecting each other
- Directly adapts to most automatic wire processing machines

SCOPE

Products: 2.00mm (.079") Pitch Wire-to-Board Crimp Terminal, 24-30 AWG.

Terminal Series No.	Terminal Order No.		Wire Size		Insulation Diameter				Strip Length	
					IPC/WHMA-A620 ♦		Terminal ♦♦			
					AWG	mm ²	mm	In.	mm	In.
50212	50212-8000	39-00-0424	24-30	0.20-0.05	0.92-1.30	.036-.051	0.80-1.40	.031-.055	1.30-1.80	.051-.071
50394	50394-8051	50394-8099	24-30	0.20-0.05	0.92-1.30	.036-.051	0.80-1.40	.031-.055	1.30-1.80	.051-.071
	50394-8052	50394-8999								
	50394-8054									
59354	59354-8081	59354-8099	24-30	0.20-0.05	0.92-1.30	.036-.051	0.80-1.40	.031-.055	1.30-1.80	.051-.071

♦ To achieve optimum IPC-A620 insulation crimps, use this insulation OD range.
♦♦ Overall insulation OD specification for terminal.

DEFINITION OF TERMS

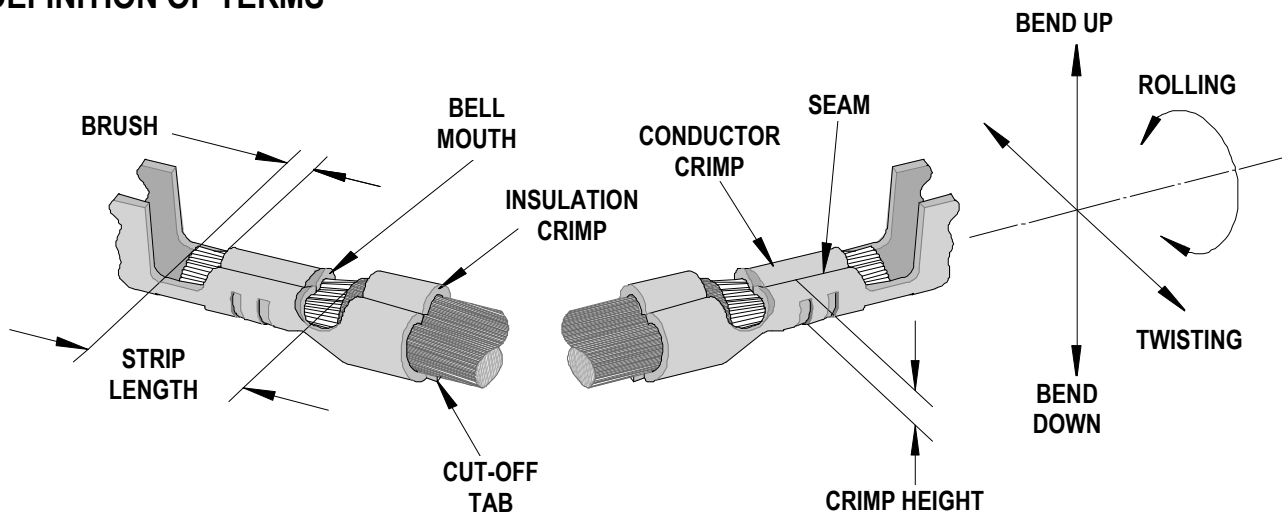

The above terminal drawing is a generic terminal representation. It is not an image of a terminal listed in the scope.

CRIMP SPECIFICATION

Terminal Series No.	Bell mouth		Cut-off Tab Maximum		Conductor Brush	
	mm	In.	mm	In.	mm	In.
50212	0.05-0.35	.002-.014	0.20	.008	0.00-0.50	.000-.020
50394	0.05-0.35	.002-.014	0.20	.008	0.00-0.50	.000-.020
59354	0.05-0.35	.002-.014	0.20	.008	0.00-0.50	.000-.020

Terminal Series No.	Bend up	Bend down	Twist	Roll	Punch Width (Ref)				Seam
					Conductor		Insulation		
	Degree		Degree		mm	In	mm	In	
50212	4	3	3	4	1.00	.039	1.40	.055	Seam shall not be open and no wire allowed out of the crimping area
50394	4	3	3	4	1.00	.039	1.40	.055	
59354	4	3	3	4	1.00	.039	1.40	.055	

After crimping, the conductor profile should measure the following.

Terminal Series No.	Wire Size		Conductor Crimp Height		Pull Force Minimum	
	AWG	mm ²	mm	In.	N	Lb.
50212	24	0.20	0.60-0.65	.024-.026	29.3	6.60
	26	0.12	0.59-0.64	.023-.025	19.6	4.40
	28	0.08	0.56-0.61	.022-.024	9.8	2.20
	30	0.05	0.53-0.58	.021-.023	4.9	1.10
50394	24	0.20	0.60-0.65	.024-.026	29.3	6.60
	26	0.12	0.59-0.64	.023-.025	19.6	4.40
	28	0.08	0.56-0.61	.022-.024	9.8	2.20
	30	0.05	0.53-0.58	.021-.023	4.9	1.10
59354	24	0.20	0.60-0.65	.024-.026	29.3	6.60
	26	0.12	0.59-0.64	.023-.025	19.6	4.40
	28	0.08	0.56-0.61	.022-.024	9.8	2.20
	30	0.05	0.53-0.58	.021-.023	4.9	1.10

Pull Force should be measured with no influence from the insulation crimp.
The above specifications are guidelines to an optimum crimp.

PARTS LIST

FineAdjust Applicator 63900-5200				
Item	Order No	Engineering No.	Description	Quantity
Perishable Tooling				
	63900-5270	63900-5270	Tool Kit (All "Y" Items)	REF
1	63444-1003	63444-1003	Conductor Punch	1 Y
2	63445-1013	63445-1013	Conductor Anvil	1 Y
3	63446-1430	63446-1430	Insulation Punch	1 Y
4	63445-1405	63445-1405	Insulation Anvil	1 Y
5	63443-0003	63443-0003	Front Cut-Off Plunger	1 Y
6	63443-0012	63443-0012	Front Plunger Retainer	1 Y
Other Components(REF 005250)				
7	11-18-4083	60707-8	Feed Guide	1
8	11-24-1067	4996-4	Cut-Off Plunger Spring	1
9	11-40-4039	8302-5	Plunger Striker	1
10	63443-0009	63443-0009	Front Scrap Chute	1
11	63443-0024	63443-0024	Key	1
12	63443-0090	63443-0090	Wire Stop	1
13	63443-1703	63443-1703	17.30mm Height Spacer	1
14	63443-2217	63443-2217	17.00mm Coarse Spacer	1
15	63443-2308	63443-2308	3.40mm Fine Spacer	1
16	63443-6111	63443-6111	Rear Cover	1
Frame				
17	63800-4901	63800-4901	Top	1
18	63801-3281	63801-3281	Base	1
19	63801-4650	63801-4650	Track	1
Hardware				
20	N/A	N/A	M3 by 6 Long SHCS	2**
21	N/A	N/A	M3 by 6 Long FHCS	1**
22	N/A	N/A	M4 by 6 Long SHCS	2**
23	N/A	N/A	M4 by 12 Long BHCS	2**
24	N/A	N/A	M4 by 50 Long SHCS	2**
25	N/A	N/A	M5 by 12 Long SHCS	1**
26	N/A	N/A	#10-32 by 3/8" Long Flat Point SSS	1**
27	N/A	N/A	#10-32 Hex Jam Nut	1**
** Available from an industrial supply company such as MSC (1-800-645-7270).				

NOTES

1. Molex recommends an extra perishable tooling kit be maintained at your facility.
2. Verify tooling alignment by manually cycling the press and Applicator before crimping under power. Check that all screws are tight.
3. Slugs, Terminals, Dirt and Oil should be kept clear of work area.
4. Wear safety glasses at all times.
5. For recommended maintenance refer to the FineAdjust Manual.

CAUTION: This applicator should only be used in a press with a shut height of 135.8mm (5.346"). Tooling damage could result at a lower setting.

CAUTION: To prevent injury never operate this Applicator without the guards supplied with the press or wire-processing machine in place. Reference the press or wire processing manufacturer's instruction manual.

CAUTION: Molex crimp specifications are valid only when used with Molex terminals, applicators and tooling.

Americas Headquarters
Lisle, Illinois 60532 U.S.A.
1-800-78MOLEX
amerinfo@molex.com

Far East North Headquarters
Yamato, Kanagawa, Japan
81-462-65-2324
feninfo@molex.com

Far East South Headquarters
Jurong, Singapore
65-6-268-6868
fesinfo@molex.com

European Headquarters
Munich, Germany
49-89-413092-0
eurinfo@molex.com

Corporate Headquarters
2222 Wellington Ct.
Lisle, IL 60532 U.S.A.
630-969-4550
Fax: 630-969-1352

Visit our Web site at <http://www.molex.com>



Компания «ЭлектроПласт» предлагает заключение долгосрочных отношений при поставках импортных электронных компонентов на взаимовыгодных условиях!

Наши преимущества:

- Оперативные поставки широкого спектра электронных компонентов отечественного и импортного производства напрямую от производителей и с крупнейших мировых складов;
- Поставка более 17-ти миллионов наименований электронных компонентов;
- Поставка сложных, дефицитных, либо снятых с производства позиций;
- Оперативные сроки поставки под заказ (от 5 рабочих дней);
- Экспресс доставка в любую точку России;
- Техническая поддержка проекта, помощь в подборе аналогов, поставка прототипов;
- Система менеджмента качества сертифицирована по Международному стандарту ISO 9001;
- Лицензия ФСБ на осуществление работ с использованием сведений, составляющих государственную тайну;
- Поставка специализированных компонентов (Xilinx, Altera, Analog Devices, Intersil, Interpoint, Microsemi, Aeroflex, Peregrine, Syfer, Eurofarad, Texas Instrument, Miteq, Cobham, E2V, MA-COM, Hittite, Mini-Circuits, General Dynamics и др.);

Помимо этого, одним из направлений компании «ЭлектроПласт» является направление «Источники питания». Мы предлагаем Вам помощь Конструкторского отдела:

- Подбор оптимального решения, техническое обоснование при выборе компонента;
- Подбор аналогов;
- Консультации по применению компонента;
- Поставка образцов и прототипов;
- Техническая поддержка проекта;
- Защита от снятия компонента с производства.



Как с нами связаться

Телефон: 8 (812) 309 58 32 (многоканальный)

Факс: 8 (812) 320-02-42

Электронная почта: org@eplast1.ru

Адрес: 198099, г. Санкт-Петербург, ул. Калинина, дом 2, корпус 4, литера А.