

# UP5

## High power, drum inductors



### Description

- 18.54 x 15.24 x 7.11mm maximum surface mount package
- Ferrite core material
- Inductance range from 1.0 $\mu$ H to 1000 $\mu$ H
- Current range from 0.56 to 20 Amps
- Frequency range up to 1MHz
- RoHS compliant

### Applications

- Buck or boost inductor
- Desktop computer
- Workstations/servers
- DVD Players
- Portable power devices
- Base stations
- Industrial power supplies
- Output filter chokes
- Test equipment instrumentation

### Environmental Data

- Storage temperature range: -40°C to +125°C
- Operating temperature range: -40°C to +125°C (ambient plus self-temperature rise)
- Solder reflow temperature: J-STD-020D compliant



**Product Specifications**

Part Number <sup>5</sup>	OCL <sup>1</sup> $\mu\text{H} \pm 20\%$	I <sub>rms</sub> <sup>2</sup> (amps)	sat <sup>3</sup> (amps) @25°C	SRF MHz typical	DCR m $\Omega$ @ 20°C Maximum	K-factor <sup>4</sup>
UP5-1R0-R	1.0	8.6	20.0	140	9.0	73.61
UP5-1R5-R	1.5	7.5	18.0	110	12.0	60.22
UP5-2R2-R	2.2	7.1	16.0	75.0	14.0	50.96
UP5-3R3-R	3.3	6.2	14.0	70.0	18.0	44.16
UP5-5R6-R	5.6	5.3	12.0	45.0	20.0	31.55
UP5-100-R	10.0	4.3	10.0	21.0	31.0	24.54
UP5-150-R	15.0	4.0	8.0	16.0	36.0	20.07
UP5-220-R	22.0	3.5	7.0	13.0	47.0	16.99
UP5-330-R	33.0	3.0	5.5	11.0	66.0	14.09
UP5-470-R	47.0	2.6	4.5	9.0	86.0	11.62
UP5-680-R	68.0	2.3	3.5	6.5	130	9.60
UP5-101-R	100	1.8	3.0	5.7	190	7.98
UP5-151-R	150	1.5	2.6	4.5	250	6.56
UP5-221-R	220	1.2	2.4	3.7	380	5.39
UP5-331-R	330	1.0	1.9	3.0	560	4.39
UP5-471-R	470	0.82	1.4	2.7	850	3.70
UP5-681-R	680	0.72	1.2	2.2	1100	3.08
UP5-102-R	1000	0.56	1.0	2.0	1800	2.54

1. OpenCircuitInductance(OCL)TestParameters:100kHz,0.25Vrms,0.0Aac
2. I<sub>rms</sub>: DC current for an approximate  $\Delta T$  rise of 40°C without core loss. Derating is necessary for AC currents. PCB layout, trace thickness and width, air-flow and proximity of other heat generating components will affect the temperature rise. It is recommended the part temperature not exceed 125°C under worst case operating conditions verified in the end application.
3. Isat: Peak current for approximately 10% rolloff at 25°C.
4. K-factor: Used to determine Bp-p for core loss (see graph).  $Bp-p = K \cdot L \cdot \Delta I$ , Bp-p (Gauss), K: (K-factor from table), L: (inductance in  $\mu\text{H}$ ),  $\Delta I$  (peak-to-peak ripple current in amps).
5. Part Number Definition: UP5-xxx-R
  - UP5 = Product code and size
  - xxx = Inductance value in  $\mu\text{H}$ , R = decimal point. If no R is present, then third digit equals the number of zeros.
  - "-R" suffix = RoHS compliant

**Dimensions (mm)**

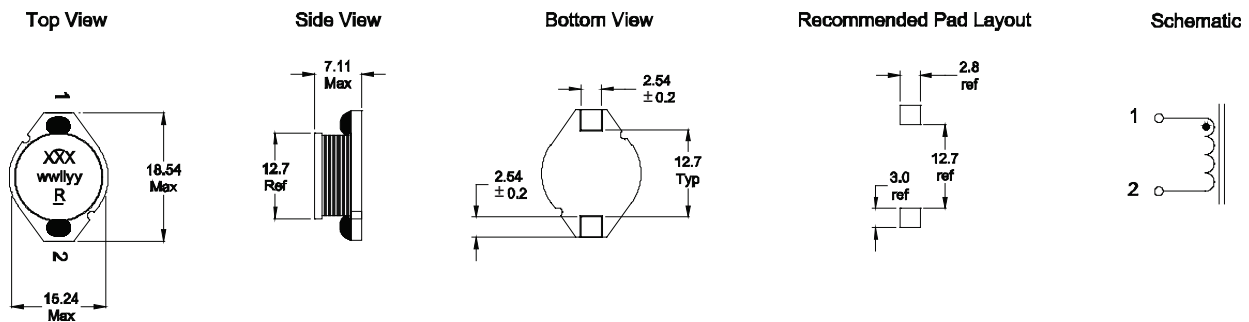

xxx = Inductance value in  $\mu\text{H}$  (R = Decimal point).  
 If no "R" is present, then the third digit equals the number of zeros.  
 wwlllyy = Date code R = Revision level

**Packaging information**

Supplied in tape-and-reel packaging, 250 parts per reel, 13" diameter reel.

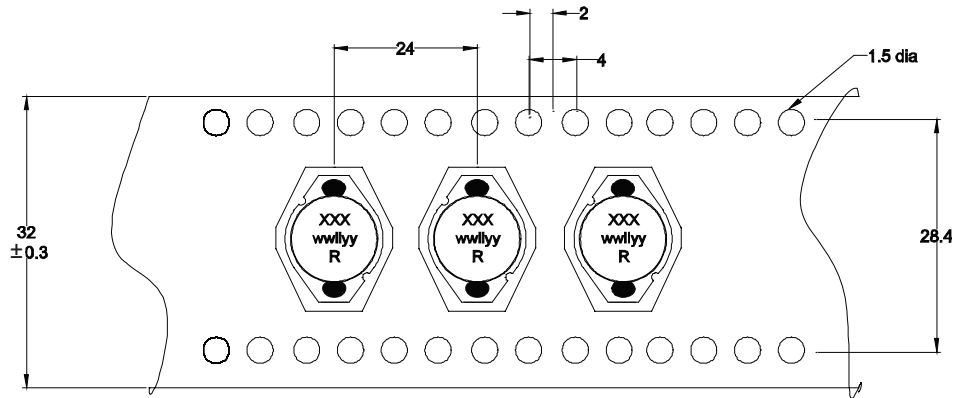

**Temperature rise vs. total loss**



Core loss

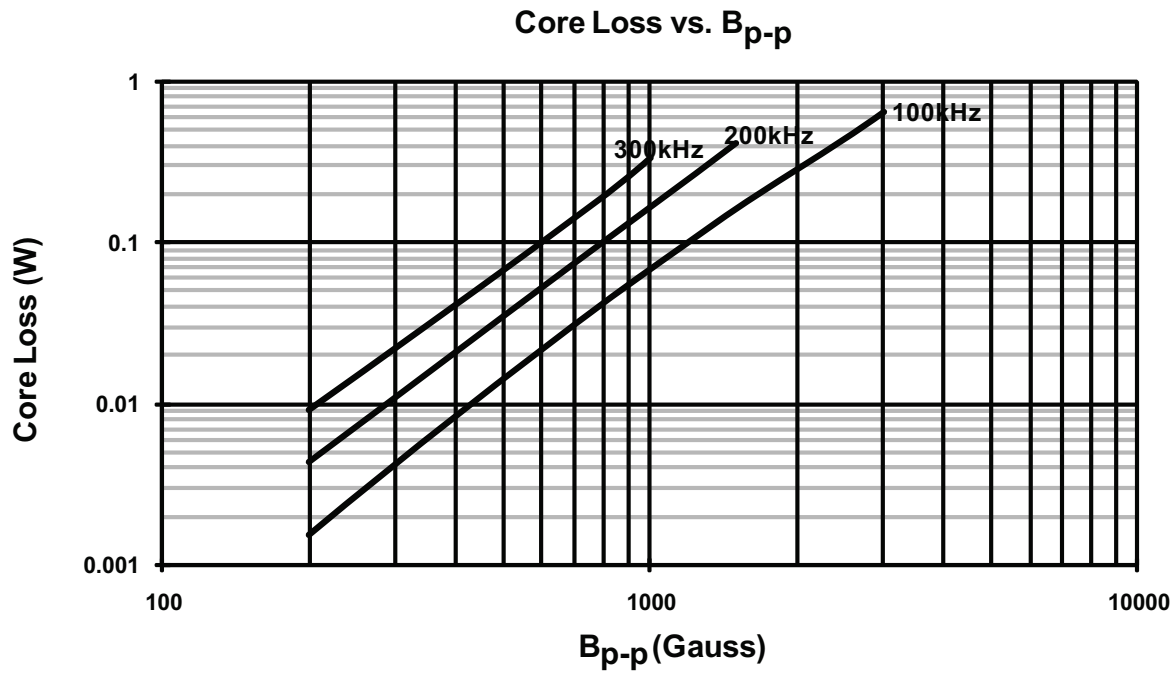

Inductance characteristics

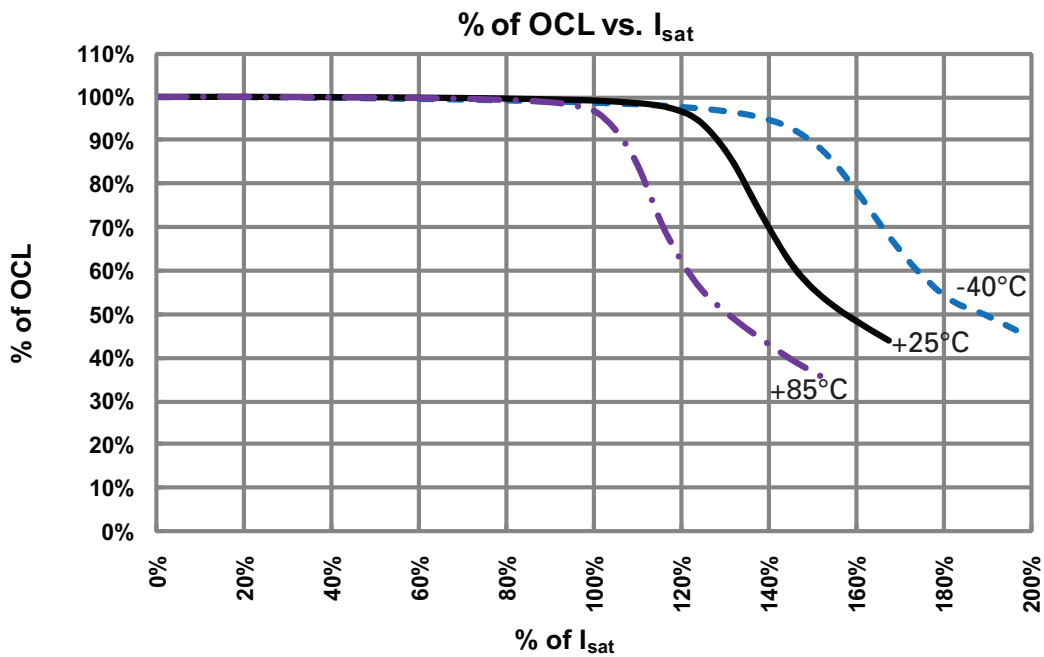

**Solder reflow profile**

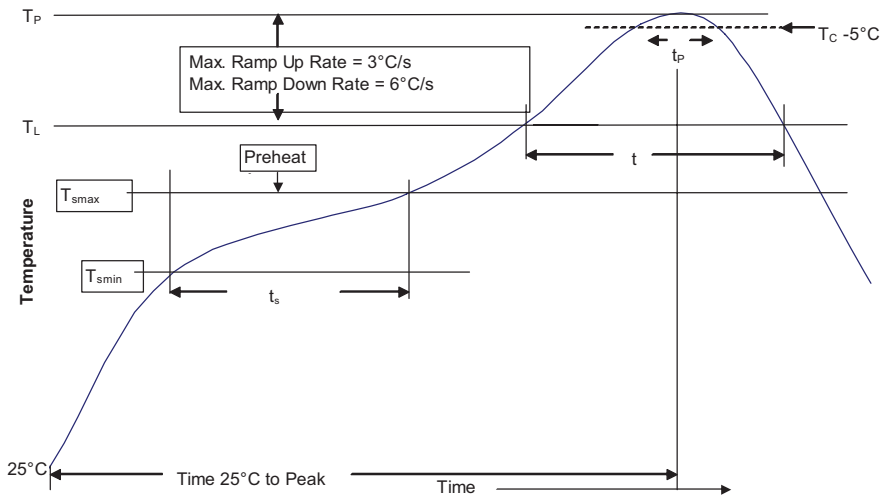

**Table 1 - Standard SnPb Solder ( $T_c$ )**

Package Thickness	Volume mm <sup>3</sup> <350	Volume mm <sup>3</sup> ≥350
<2.5mm)	235°C	220°C
≥2.5mm	220°C	220°C

**Table 2 - Lead (Pb) Free Solder ( $T_c$ )**

Package Thickness	Volume mm <sup>3</sup> <350	Volume mm <sup>3</sup> 350 - 2000	Volume mm <sup>3</sup> >2000
<1.6mm	260°C	260°C	260°C
1.6 - 2.5mm	260°C	250°C	245°C
>2.5mm	250°C	245°C	245°C

**Reference JDEC J-STD-020D**

Profile Feature	Standard SnPb Solder	Lead (Pb) Free Solder
Preheat and Soak		
• Temperature min. ( $T_{smin}$ )	100°C	150°C
• Temperature max. ( $T_{smax}$ )	150°C	200°C
• Time ( $T_{smin}$ to $T_{smax}$ ) ( $t_s$ )	60-120 Seconds	60-120 Seconds
Average ramp up rate $T_{smax}$ to $T_p$	3°C/ Second Max.	3°C/ Second Max.
Liquidous temperature ( $T_L$ )	183°C	217°C
Time at liquidous ( $t_L$ )	60-150 Seconds	60-150 Seconds
Peak package body temperature ( $T_p$ )*	Table 1	Table 2
Time ( $t_p$ )** within 5 °C of the specified classification temperature ( $T_c$ )	20 Seconds**	30 Seconds**
Average ramp-down rate ( $T_p$ to $T_{smax}$ )	6°C/ Second Max.	6°C/ Second Max.
Time 25°C to Peak Temperature	6 Minutes Max.	8 Minutes Max.

\* Tolerance for peak profile temperature ( $T_p$ ) is defined as a supplier minimum and a user maximum.  
\*\* Tolerance for time at peak profile temperature ( $t_p$ ) is defined as a supplier minimum and a user maximum.

Life Support Policy: Eaton does not authorize the use of any of its products for use in life support devices or systems without the express written approval of an officer of the Company. Life support systems are devices which support or sustain life, and whose failure to perform, when properly used in accordance with instructions for use provided in the labeling, can be reasonably expected to result in significant injury to the user.

Eaton reserves the right, without notice, to change design or construction of any products and to discontinue or limit distribution of any products. Eaton also reserves the right to change or update, without notice, any technical information contained in this bulletin.

**Eaton**  
**Electronics Division**  
1000 Eaton Boulevard  
Cleveland, OH 44122  
United States  
www.eaton.com/elx

© 2015 Eaton  
All Rights Reserved  
Printed in USA  
Publication No. 4409 BU09493  
December 2015

Eaton is a registered trademark.  
All other trademarks are property of their respective owners.



Компания «ЭлектроПласт» предлагает заключение долгосрочных отношений при поставках импортных электронных компонентов на взаимовыгодных условиях!

Наши преимущества:

- Оперативные поставки широкого спектра электронных компонентов отечественного и импортного производства напрямую от производителей и с крупнейших мировых складов;
- Поставка более 17-ти миллионов наименований электронных компонентов;
- Поставка сложных, дефицитных, либо снятых с производства позиций;
- Оперативные сроки поставки под заказ (от 5 рабочих дней);
- Экспресс доставка в любую точку России;
- Техническая поддержка проекта, помощь в подборе аналогов, поставка прототипов;
- Система менеджмента качества сертифицирована по Международному стандарту ISO 9001;
- Лицензия ФСБ на осуществление работ с использованием сведений, составляющих государственную тайну;
- Поставка специализированных компонентов (Xilinx, Altera, Analog Devices, Intersil, Interpoint, Microsemi, Aeroflex, Peregrine, Syfer, Eurofarad, Texas Instrument, Miteq, Cobham, E2V, MA-COM, Hittite, Mini-Circuits, General Dynamics и др.);

Помимо этого, одним из направлений компании «ЭлектроПласт» является направление «Источники питания». Мы предлагаем Вам помощь Конструкторского отдела:

- Подбор оптимального решения, техническое обоснование при выборе компонента;
- Подбор аналогов;
- Консультации по применению компонента;
- Поставка образцов и прототипов;
- Техническая поддержка проекта;
- Защита от снятия компонента с производства.



#### Как с нами связаться

**Телефон:** 8 (812) 309 58 32 (многоканальный)

**Факс:** 8 (812) 320-02-42

**Электронная почта:** [org@eplast1.ru](mailto:org@eplast1.ru)

**Адрес:** 198099, г. Санкт-Петербург, ул. Калинина, дом 2, корпус 4, литера А.