

**PRECISION P-CHANNEL EPAD® MOSFET ARRAY  
QUAD ENHANCED MODE MATCHED PAIR**

**V<sub>GS(th)</sub> = -0.80V**

**GENERAL DESCRIPTION**

ALD310708A/ALD310708 high precision monolithic quad P-Channel MOSFET arrays are matched at the factory using ALD's proven EPAD® CMOS technology. This device is available in a quad version and is a member of the EPAD® Matched Pair MOSFET Family. The ALD310708A/ALD310708 is a P-channel version of the popular ALD110808A/ALD110808 Precision Threshold device. Together, these two MOSFET series enable complementary precision N-Channel and P-Channel MOSFET array based circuits.

Intended for low voltage and low power small signal applications, the ALD310708A/ALD310708 features precision -0.80V Gate Threshold Voltage, which enables circuit designs with very low operating voltages such as 2V power supplies where the circuits operate below the threshold voltage of the ALD310708A/ALD310708. This feature also enhances input/output signal operating ranges, especially in very low operating voltage environments. With these low threshold precision devices, a circuit with multiple cascading stages can be constructed to operate at extremely low supply or bias voltage levels. ALD310708A/ALD310708 also features high input impedance ( $2.5 \times 10^{10}\Omega$ ) and high DC current gain ( $>10^8$ ).

ALD310708A/ALD310708 MOSFETs are designed for exceptional matching of device electrical characteristics. The Gate Threshold Voltage V<sub>GS(th)</sub> is set precisely at -0.80V +/-0.02V, featuring a typical offset voltage of only +/-0.001V (1mV). As these devices are on the same monolithic chip, they also exhibit excellent temperature tracking characteristics. They are versatile design components for a broad range of precision analog applications such as basic building blocks for current mirrors, matching circuits, current sources, differential amplifier input stages, transmission gates, and multiplexers. These devices also excel in limited operating voltage applications such as very low level precision voltage-clamps. In addition to matched pair electrical characteristics, each individual MOSFET exhibits individual well controlled manufacturing characteristics, enabling the user to depend on tight design limits from different production batches.

(Continued on next page)

**BLOCK DIAGRAM**

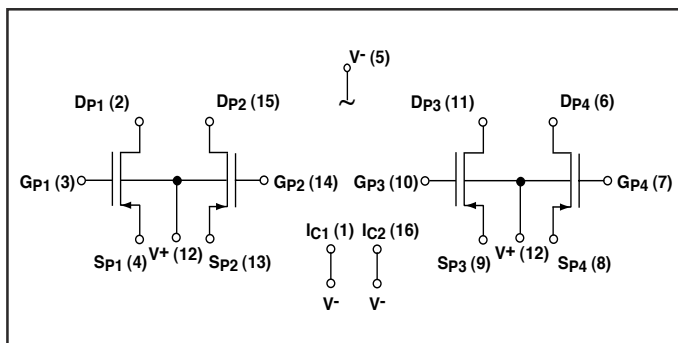

**ORDERING INFORMATION** ("L" suffix denotes lead-free (RoHS))

Operating Temperature Range * 0°C to +70°C	
16-Pin SOIC Package	16-Pin Plastic Dip Package
ALD310708ASCL ALD310708SCL	ALD310708APCL ALD310708PCL

\*Contact factory for industrial temp. range or user-specified threshold voltage values.

**APPLICATIONS**

- 0.5% precision current mirrors and current sources
- Low Tempco ( $\leq 50\text{ppm}/^\circ\text{C}$ ) current mirrors/sources
- Energy harvesting circuits
- Very low voltage analog and digital circuits
- Backup battery circuits & power failure detectors
- Precision low level voltage-clamps
- Low level zero-crossing detector
- Source followers and buffers
- Precision capacitive probes and sensor interfaces
- Precision charge detectors and charge integrators
- Discrete differential amplifier input stage
- Peak-detectors and level-shifters
- High-side switches and Sample-and-Hold switches
- Precision current multipliers
- Discrete analog switches / multiplexers
- Discrete voltage comparators

**FEATURES & BENEFITS**

- Precision matched Gate Threshold Voltages
- Precision offset voltages (V<sub>OS</sub>):  
ALD310708A: 2mV max.  
ALD310708: 10mV max.
- Sub-threshold voltage operation
- Low min. operating voltage of less than 0.8V
- Ultra low min. operating current of less than 1nA
- Nano-power operation
- Wide dynamic operating current ranges
- Exponential operating current ranges
- Matched transconductance and output conductance
- Matched and tracked temperature characteristics
- Tight lot-to-lot parametric control
- Positive, zero, and negative V<sub>GS(th)</sub> tempco bias currents
- Low input capacitance
- Low input/output leakage currents

**PIN CONFIGURATION**

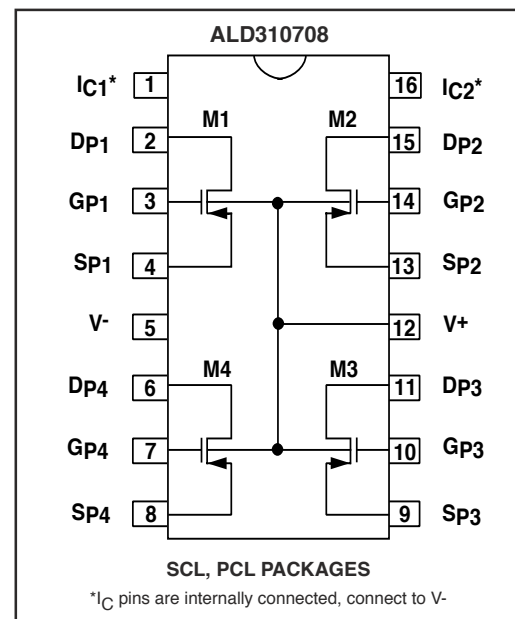

\*I<sub>C</sub> pins are internally connected, connect to V-

## GENERAL DESCRIPTION (cont.)

These devices are built to offer minimum offset voltage and differential thermal response, and they can also be used for switching and amplifying applications in  $-0.80\text{V}$  to  $-8.0\text{V}$  ( $\pm 0.40\text{V}$  to  $\pm 4.0\text{V}$ ) powered systems where low input bias current, low input capacitance, and fast switching speed are desired. These devices, exhibiting well controlled turn-off and sub-threshold characteristics, operate the same as standard enhancement mode P-Channel MOSFETs. However, the precision of the Gate Threshold Voltage enable two key additional characteristics, or operating features. First, the operating current level varies exponentially with gate bias voltage at

or below the Gate Threshold Voltage (subthreshold region). Second, the circuit can be biased and operated in the subthreshold region with nA of bias current and nW of power dissipation.

For most general applications, connect the V+ pin to the most positive voltage and the V- and IC (internally-connected) pins to the most negative voltage in the system. All other pins must have voltages within these voltage limits at all times. Standard ESD protection facilities and procedures for static sensitive devices are required when handling these devices.

## ABSOLUTE MAXIMUM RATINGS

Drain-Source voltage, $V_{DS}$	_____	-8.0V
Gate-Source voltage, $V_{GS}$	_____	-8.0V
Operating Current	_____	80mA
Power dissipation	_____	500mW
Operating temperature range SCL, PCL	_____	0°C to +70°C
Storage temperature range	_____	-65°C to +150°C
Lead temperature, 10 seconds	_____	+260°C

**CAUTION: ESD Sensitive Device. Use static control procedures in ESD controlled environment.**

## OPERATING ELECTRICAL CHARACTERISTICS

V+ = +5V V- = GND  $T_A = 25^\circ\text{C}$  unless otherwise specified

Parameter	Symbol	ALD310708A			ALD310708			Unit	Test Conditions
		Min	Typ	Max	Min	Typ	Max		
Gate Threshold Voltage	$V_{GS(th)}$	-0.82	-0.80	-0.78	-0.82	-0.80	-0.78	V	$I_{DS} = -1\mu\text{A}$ , $V_{DS} = -0.1\text{V}$
Offset Voltage	VOS		1	2		2	10	mV	$V_{GS(th)M1} - V_{GS(th)M2}$ or $V_{GS(th)M3} - V_{GS(th)M4}$
Gate Threshold Temperature	$TCV_{GS(th)}$		-2			-2		mV/°C	
Drain Source On Current	$I_{DS(ON)}$		-1.65			-1.65		mA	$V_{GS} = V_{DS} = -5.0\text{V}$
Transconductance Current <sup>2</sup>	$G_{FS}$		570			570		$\mu\text{A/V}$	$V_{GS} = V_{DS} = -5.0\text{V}$
Transconductance Mismatch	$\Delta G_{FS}$		1			1		%	$V_{GS} = V_{DS} = -5.0\text{V}$
Output Conductance <sup>2</sup>	$G_{OS}$		48			48		$\mu\text{A/V}$	$V_{GS(th)} = -4.0\text{V}$ , $V_{DS} = -5.0\text{V}$
Drain Source On Resistance	$R_{DS(ON)}$		1.25			1.25		K $\Omega$	$V_{GS} = -5.0\text{V}$ , $V_{DS} = -0.1\text{V}$
Drain Source On Resistance Mismatch	$\Delta R_{DS(ON)}$		1			1		%	
Drain Source Breakdown	$BV_{DSX}$	-8.0			-8.0			V	
Drain Source Leakage Current <sup>1</sup>	$I_{DS(OFF)}$			400			400	pA	
Gate Leakage Current	$I_{GSS}$			200			200	pA	
Input Capacitance <sup>2</sup>	$C_{ISS}$		2.5			2.5		pF	

Notes: <sup>1</sup> Consists of junction leakage currents

<sup>2</sup> Sample tested parameters

# TYPICAL PERFORMANCE CHARACTERISTICS

## OUTPUT CHARACTERISTICS

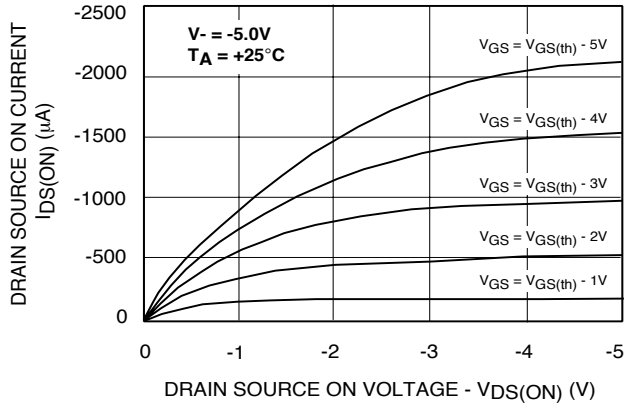

## OUTPUT CHARACTERISTICS

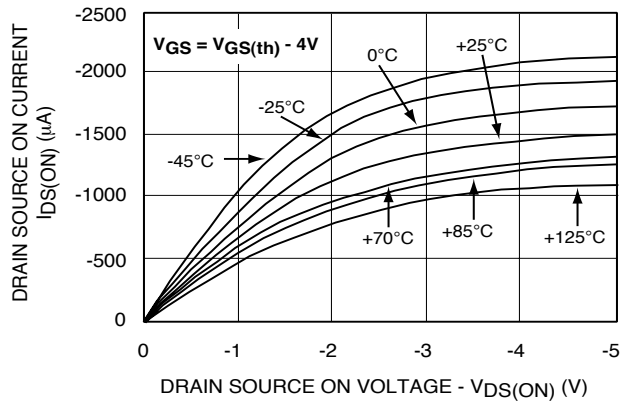

## FORWARD TRANSFER CHARACTERISTICS

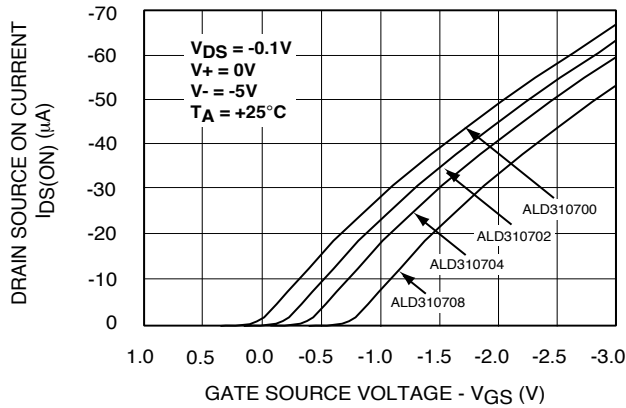

## FORWARD TRANSFER CHARACTERISTICS (SUBTHRESHOLD)

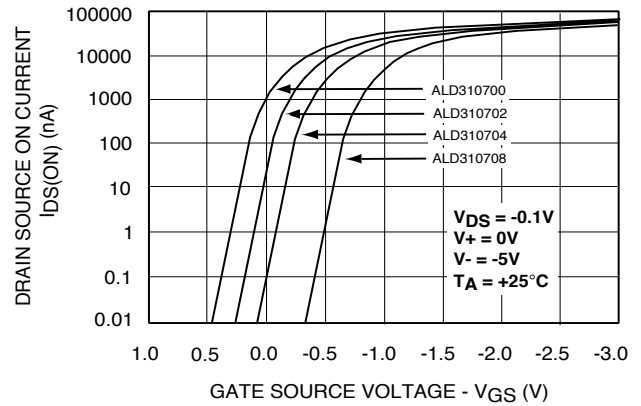

## LOW VOLTAGE OUTPUT CHARACTERISTICS

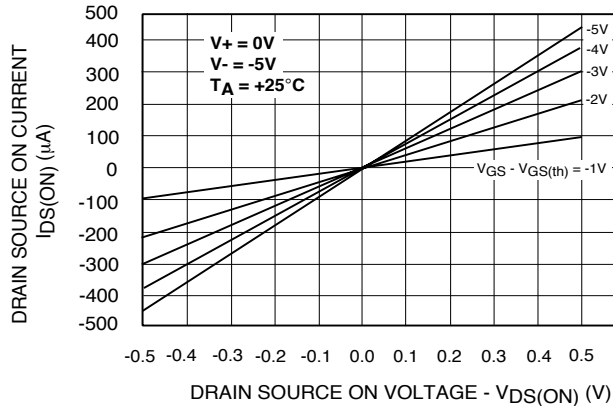

## DRAIN SOURCE ON CURRENT vs. GATE AND DRAIN SOURCE VOLTAGE

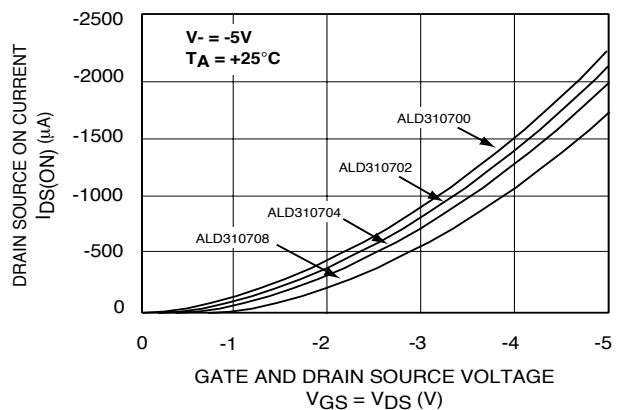

## TYPICAL PERFORMANCE CHARACTERISTICS (cont.)

**FORWARD TRANSFER CHARACTERISTICS EXPANDED (SUBTHRESHOLD)**

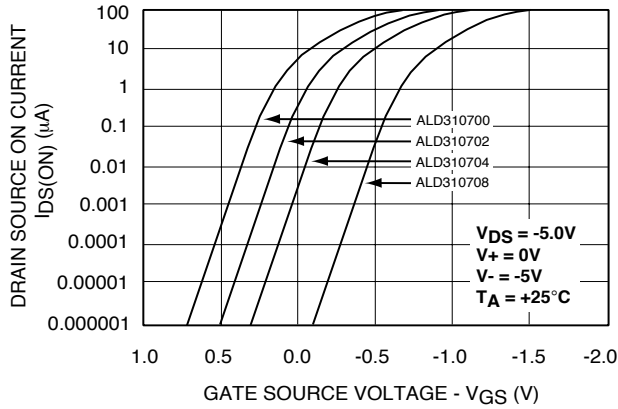

**FORWARD TRANSFER CHARACTERISTICS FURTHER EXPANDED (SUBTHRESHOLD)**

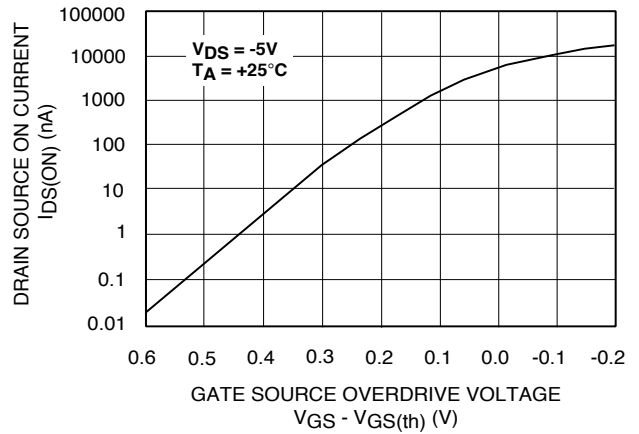

**GATE THRESHOLD VOLTAGE vs. SUBSTRATE BIAS**

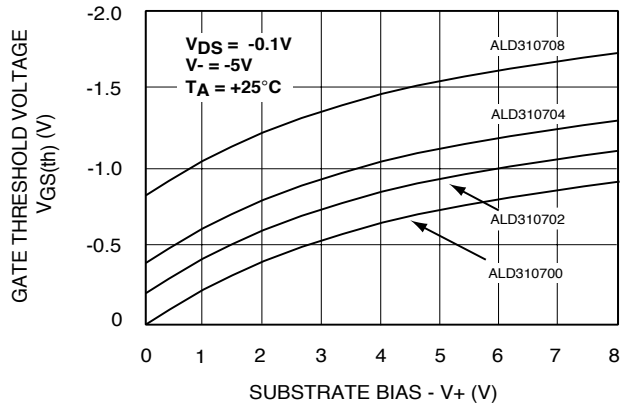

**GATE THRESHOLD VOLTAGE vs. V- VOLTAGE**

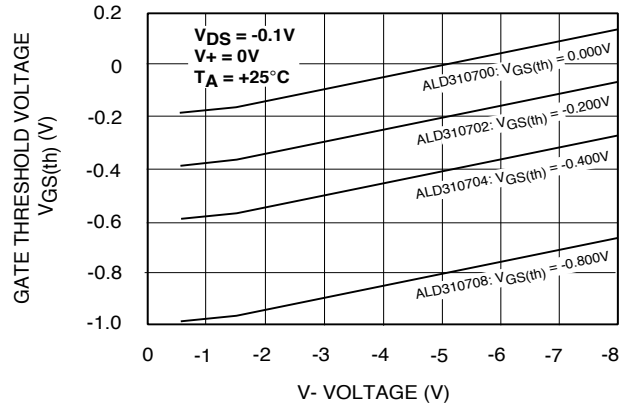

**GATE THRESHOLD VOLTAGE vs. DRAIN SOURCE VOLTAGE**

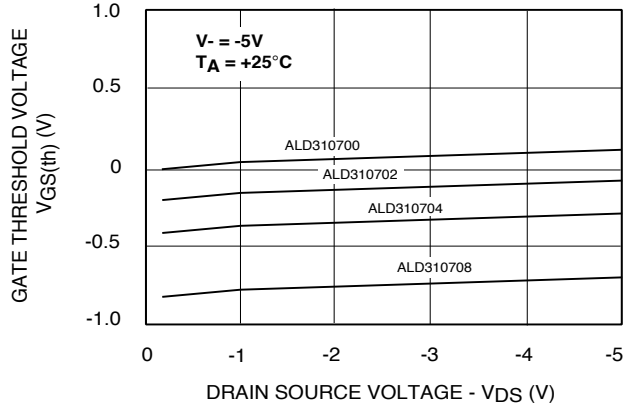

**GATE THRESHOLD VOLTAGE vs. AMBIENT TEMPERATURE**

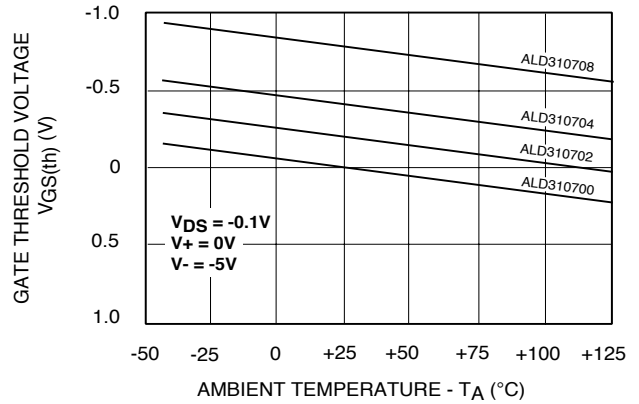

## TYPICAL PERFORMANCE CHARACTERISTICS (cont.)

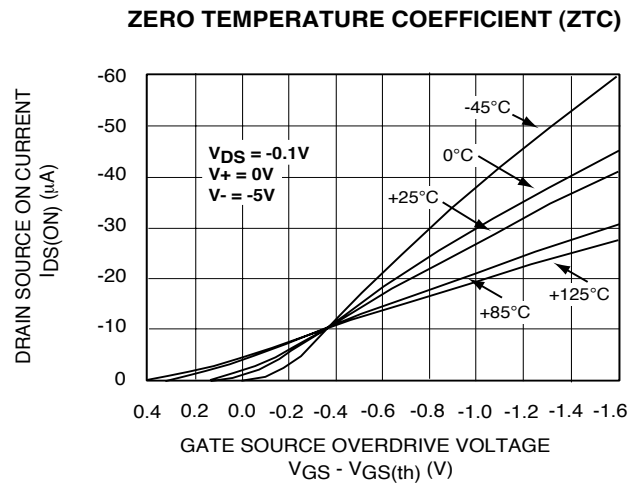
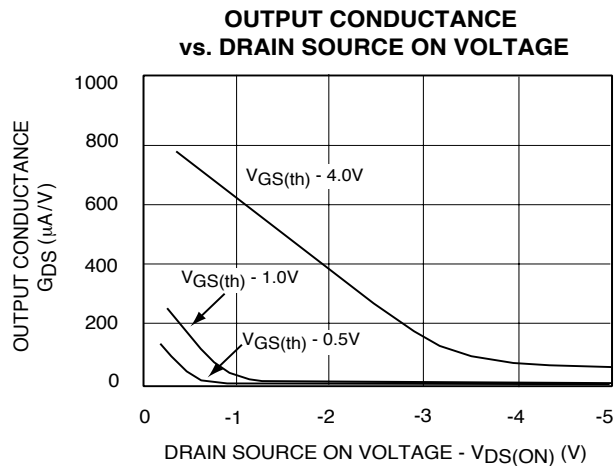
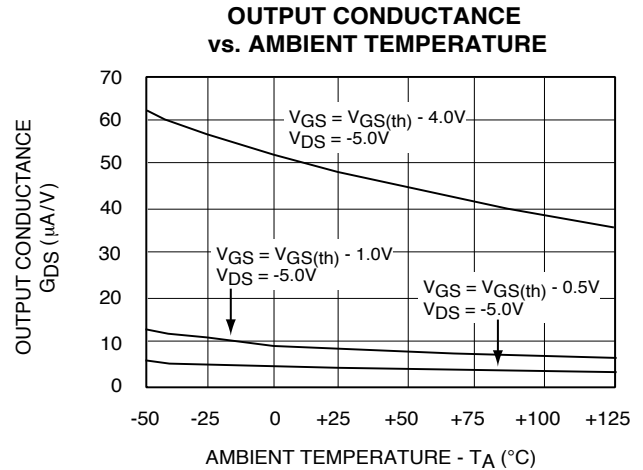
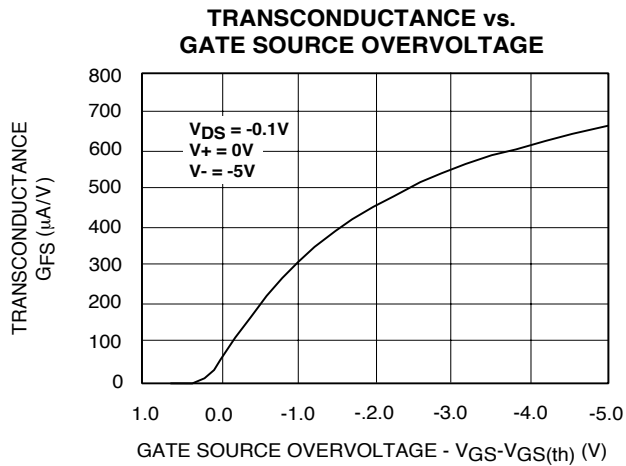
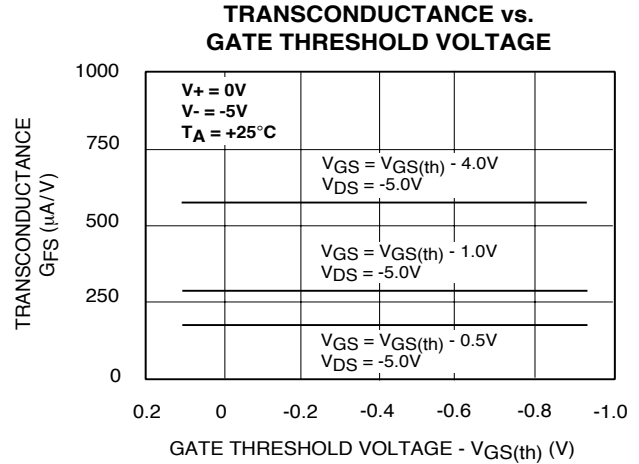
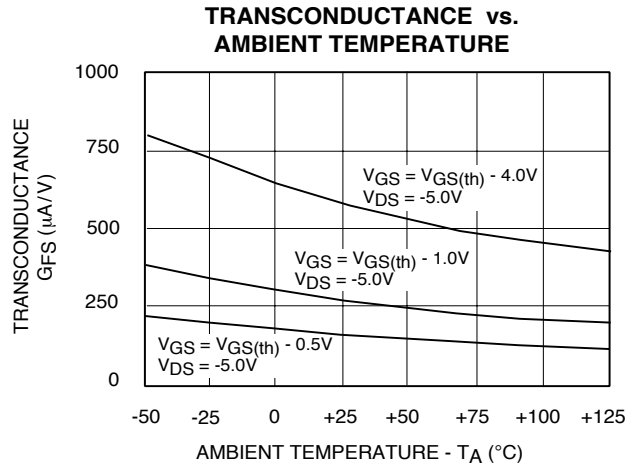

## TYPICAL APPLICATIONS

### LOW VOLTAGE CURRENT SOURCE MIRROR

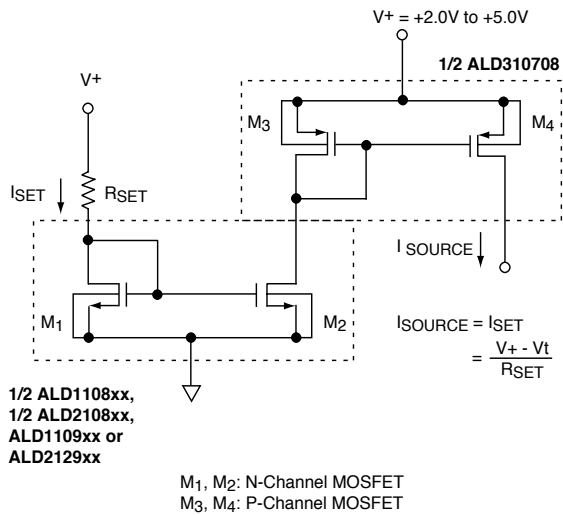

### LOW VOLTAGE CURRENT SOURCE W/ GATE CONTROL

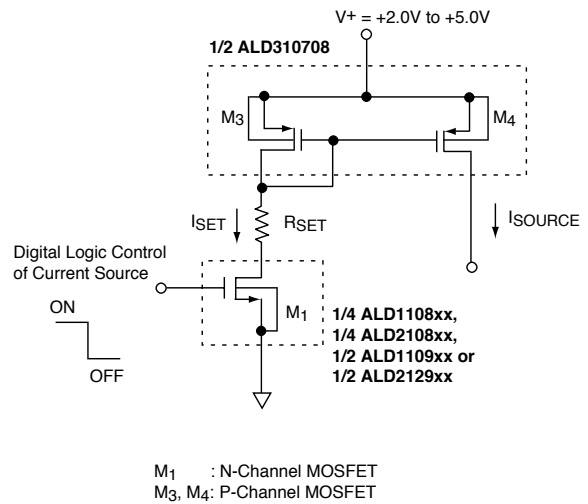

### LOW VOLTAGE DIFFERENTIAL AMPLIFIER

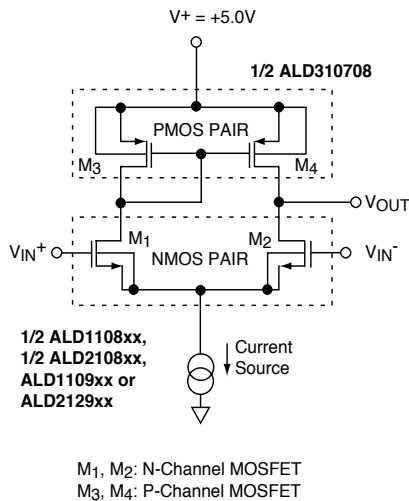

### 0.5% PRECISION LOW VOLTAGE CURRENT SOURCE MULTIPLICATION

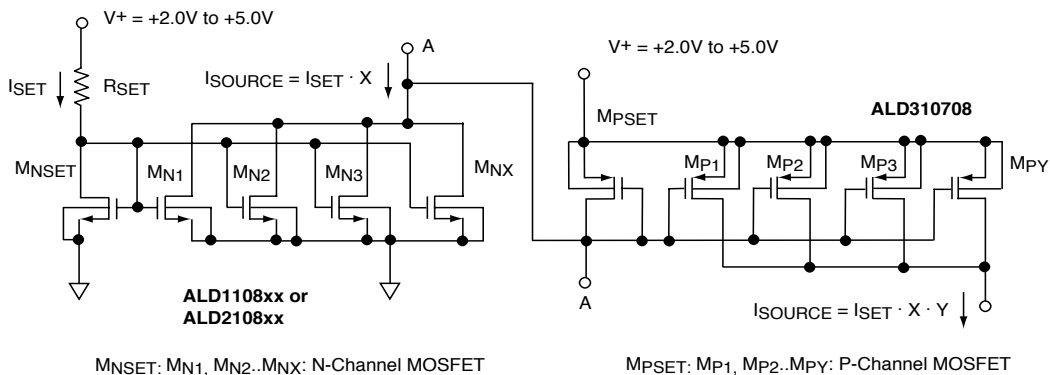

## TYPICAL APPLICATIONS (cont.)

### 0.5% LOW VOLTAGE PRECISION CURRENT MIRRORS

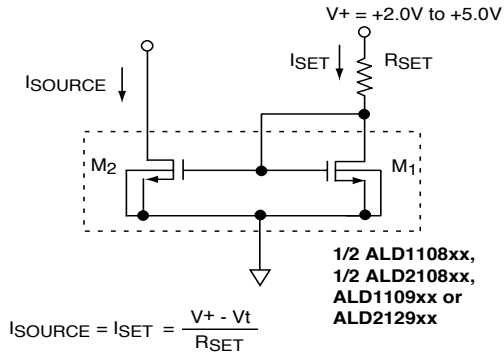

$M_1, M_2$ : N-Channel MOSFET

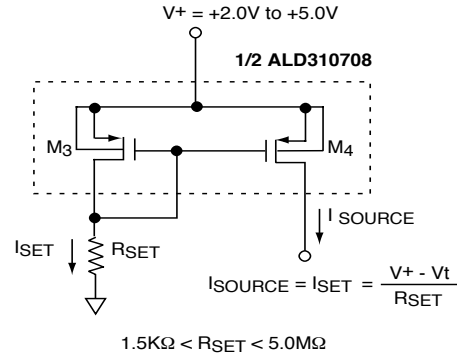

$M_3, M_4$ : P-Channel MOSFET

### 0.5% PRECISION LOW VOLTAGE CASCODE CURRENT SOURCES

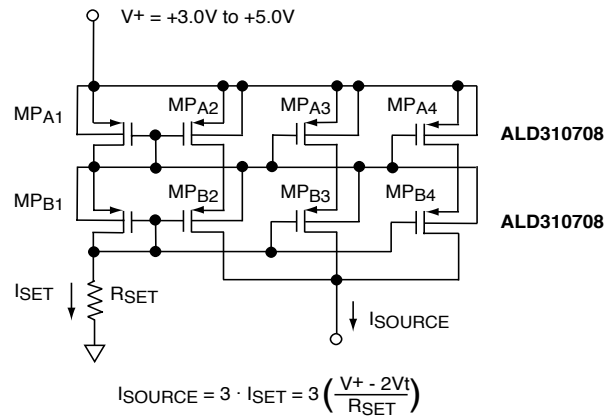

$M_{PA1} \dots M_{PA4}$ : ALD310708 P-Channel MOSFET (1st individual pkg)  
 $M_{PB1} \dots M_{PB4}$ : ALD310708 P-Channel MOSFET (2nd individual pkg)

### 0.5% PRECISION LOW TEMP CO CASCODE CURRENT SOURCES

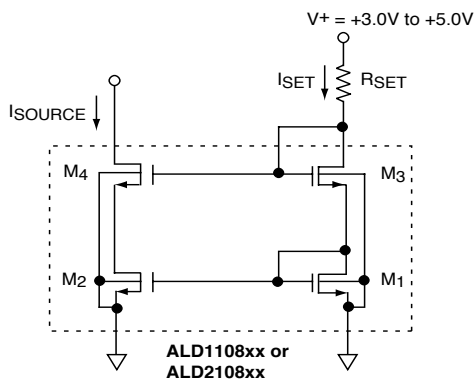

$M_1, M_2, M_3, M_4$ : N-Channel MOSFET

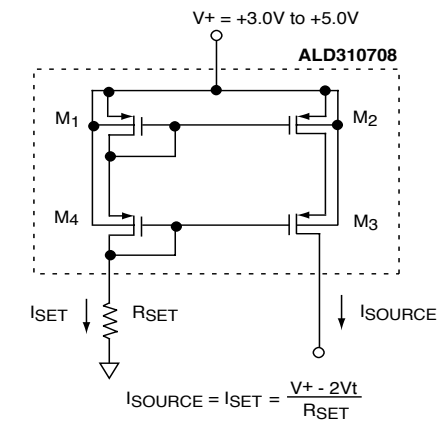

$M_1, M_2, M_3, M_4$ : P-Channel MOSFET

# SOIC-16 PACKAGE DRAWING

## 16 Pin Plastic SOIC Package

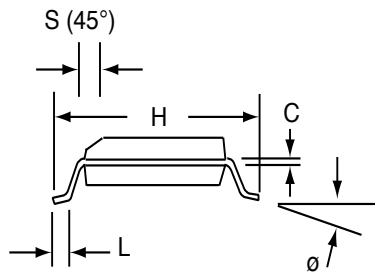
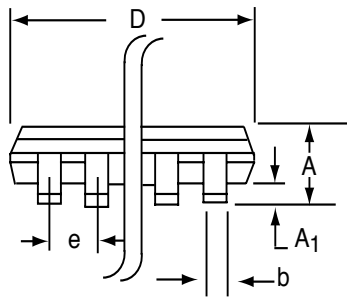
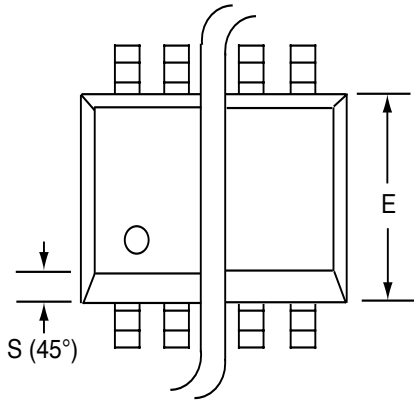

Dim	Millimeters		Inches	
	Min	Max	Min	Max
<b>A</b>	1.35	1.75	0.053	0.069
<b>A<sub>1</sub></b>	0.10	0.25	0.004	0.010
<b>b</b>	0.35	0.45	0.014	0.018
<b>C</b>	0.18	0.25	0.007	0.010
<b>D-16</b>	9.80	10.00	0.385	0.394
<b>E</b>	3.50	4.05	0.140	0.160
<b>e</b>	1.27 BSC		0.050 BSC	
<b>H</b>	5.70	6.30	0.224	0.248
<b>L</b>	0.60	0.937	0.024	0.037
<b>∅</b>	0°	8°	0°	8°
<b>S</b>	0.25	0.50	0.010	0.020



# PDIP-16 PACKAGE DRAWING

## 16 Pin Plastic DIP Package

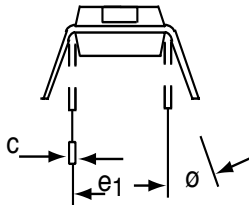
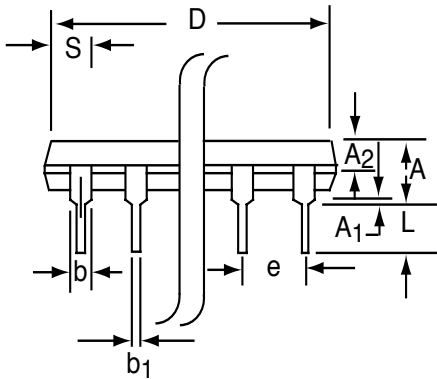
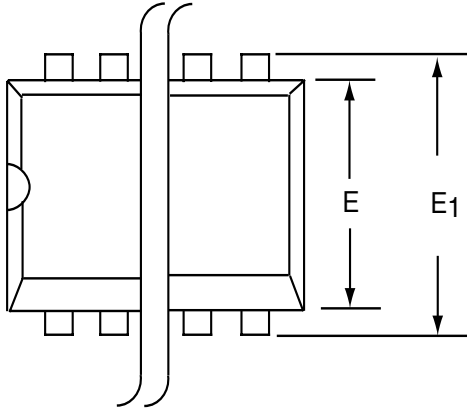

Dim	Millimeters		Inches	
	Min	Max	Min	Max
A	3.81	5.08	0.105	0.200
A <sub>1</sub>	0.38	1.27	0.015	0.050
A <sub>2</sub>	1.27	2.03	0.050	0.080
b	0.89	1.65	0.035	0.065
b <sub>1</sub>	0.38	0.51	0.015	0.020
c	0.20	0.30	0.008	0.012
D-16	18.93	21.33	0.745	0.840
E	5.59	7.11	0.220	0.280
E <sub>1</sub>	7.62	8.26	0.300	0.325
e	2.29	2.79	0.090	0.110
e <sub>1</sub>	7.37	7.87	0.290	0.310
L	2.79	3.81	0.110	0.150
S-16	0.38	1.52	0.015	0.060
θ	0°	15°	0°	15°



Компания «ЭлектроПласт» предлагает заключение долгосрочных отношений при поставках импортных электронных компонентов на взаимовыгодных условиях!

Наши преимущества:

- Оперативные поставки широкого спектра электронных компонентов отечественного и импортного производства напрямую от производителей и с крупнейших мировых складов;
- Поставка более 17-ти миллионов наименований электронных компонентов;
- Поставка сложных, дефицитных, либо снятых с производства позиций;
- Оперативные сроки поставки под заказ (от 5 рабочих дней);
- Экспресс доставка в любую точку России;
- Техническая поддержка проекта, помощь в подборе аналогов, поставка прототипов;
- Система менеджмента качества сертифицирована по Международному стандарту ISO 9001;
- Лицензия ФСБ на осуществление работ с использованием сведений, составляющих государственную тайну;
- Поставка специализированных компонентов (Xilinx, Altera, Analog Devices, Intersil, Interpoint, Microsemi, Aeroflex, Peregrine, Syfer, Eurofarad, Texas Instrument, Miteq, Cobham, E2V, MA-COM, Hittite, Mini-Circuits, General Dynamics и др.);

Помимо этого, одним из направлений компании «ЭлектроПласт» является направление «Источники питания». Мы предлагаем Вам помощь Конструкторского отдела:

- Подбор оптимального решения, техническое обоснование при выборе компонента;
- Подбор аналогов;
- Консультации по применению компонента;
- Поставка образцов и прототипов;
- Техническая поддержка проекта;
- Защита от снятия компонента с производства.



#### Как с нами связаться

**Телефон:** 8 (812) 309 58 32 (многоканальный)

**Факс:** 8 (812) 320-02-42

**Электронная почта:** [org@eplast1.ru](mailto:org@eplast1.ru)

**Адрес:** 198099, г. Санкт-Петербург, ул. Калинина, дом 2, корпус 4, литера А.