

## DESCRIPTION

Demonstration circuit 876 is a dual 1.3A white LED step-up converter with wide dimming range featuring the LT3486. The board is optimized to drive a string of six, eight, or ten white LEDs at 100mA from each of its two outputs with a PVIN input voltage range of 3V to 25V. The maximum LED output voltage must be less than 36V and the over-voltage protection at the output will limit the maximum output voltage to 36V in the case of an open circuit load. The high input voltage range, high-efficiency low-side internal 1.3A npn power switches, ground-referenced low-voltage current sense resistors, pwm pins for high dimming ratio, control pins for brightness adjust, overvoltage protection, shutdown control pin, externally programmable switching frequency, low shutdown current and internal soft-start capacitor make the LT3486 an extremely powerful and versatile LED driving IC for portable applications and displays.

DC876 has overvoltage protection at 36V if the LEDs are open or not properly attached to the terminals on the PCB. The shutdown function is activated by pulling the shutdown terminal to ground, but in shutdown the boost configuration allows the input voltage to be seen on the output and if the attached LED array leaks current at the input voltage, the LEDs may not completely turn off in shutdown. The CTRL terminals can be used to decrease the LED current by connecting the CTRL jumpers to 'terminal' instead of 'VIN'. The PWM terminals can be used to dim the LEDs with a PWM signal greater than 3.5V when the PWM jumper is connected to 'terminal' instead of 'VIN'. When the 'VIN' setting is used at either jumper, the function is disabled and the part will run at full current or without PWM dimming. If VIN is below 3.5V,

the gate of the MOSFET may not be activated and the LEDs may not turn on. For proper operation with VIN voltages below 3.5V, either external PWM signals must be used to turn the MOSFETs on or another, lower voltage, MOSFET must be used in place of the FDN5630. Some gate voltage curves are provided below.

A simple modification can be made to the DC876A board in order to change the constant current output of either channel. The sense resistor can be changed according to the equation in the datasheet and that will change the constant LED current.

The silkscreen on the demonstration circuit and the table in the schematic give a guideline of the input voltage range for a 100mA LED output at a given LED forward voltage in which the LT3486 remains below its maximum current limit.

The LT3486 datasheet gives a complete description of the part, operation and applications information. The datasheet must be read in conjunction with this Quick Start Guide for demonstration circuit 876. The LT3486 is assembled in a small 16-lead plastic TSSOP FE package with a thermally enhanced ground pad. Proper board layout is essential for maximum thermal performance. See the datasheet section 'Layout Considerations'. An additional 16-lead (5mm x 3mm) plastic DFN DHC package is available, but not on this demonstration circuit.

**Design files for this circuit board are available. Call the LTC factory.**

---

LT is a trademark of Linear Technology Corporation

## QUICK START PROCEDURE

Demonstration circuit 876 is easy to set up to evaluate the performance of the LT3486. Follow the procedure below:

**NOTE:** Make sure that the power input voltage (PVIN) does not exceed 25V and that the input voltage (VIN) does not exceed 10V.

1. Connect an array of LEDs with forward voltage less than 35V, but greater than the input voltage, to the LED+ and LED- terminals on the PCB as shown.

2. Connect a 2.5V to 10V input power supply to the VIN and GND terminals on the PCB and a 3V to 25V input power supply to the PVIN and GND terminals on the PCB.
3. Set the CTRL and PWM jumpers in the VIN position or if VIN is below 3.5V, set the PWM jumper to the terminal position and use a PWM or DC signal with a voltage higher than 3.5V.
4. Observe the bright LEDs and the constant LED current.

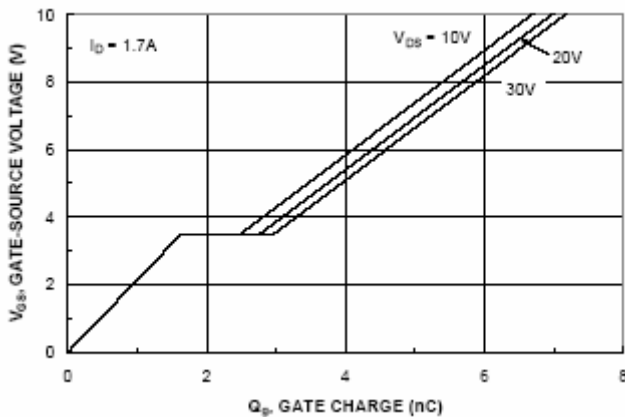

Figure 1. FDN5630 typical gate charge characteristics

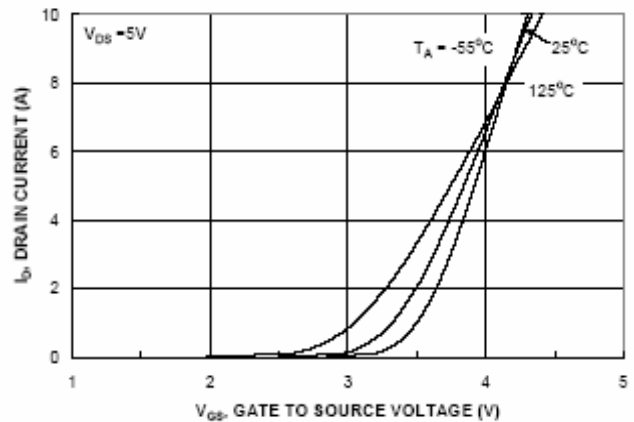

Figure 2. FDN5630 typical transfer characteristics

# QUICK START GUIDE FOR DEMONSTRATION CIRCUIT 876 DUAL 1.3A WHITE LED STEP-UP CONVERTERS WITH WIDE DIMMING RANGE

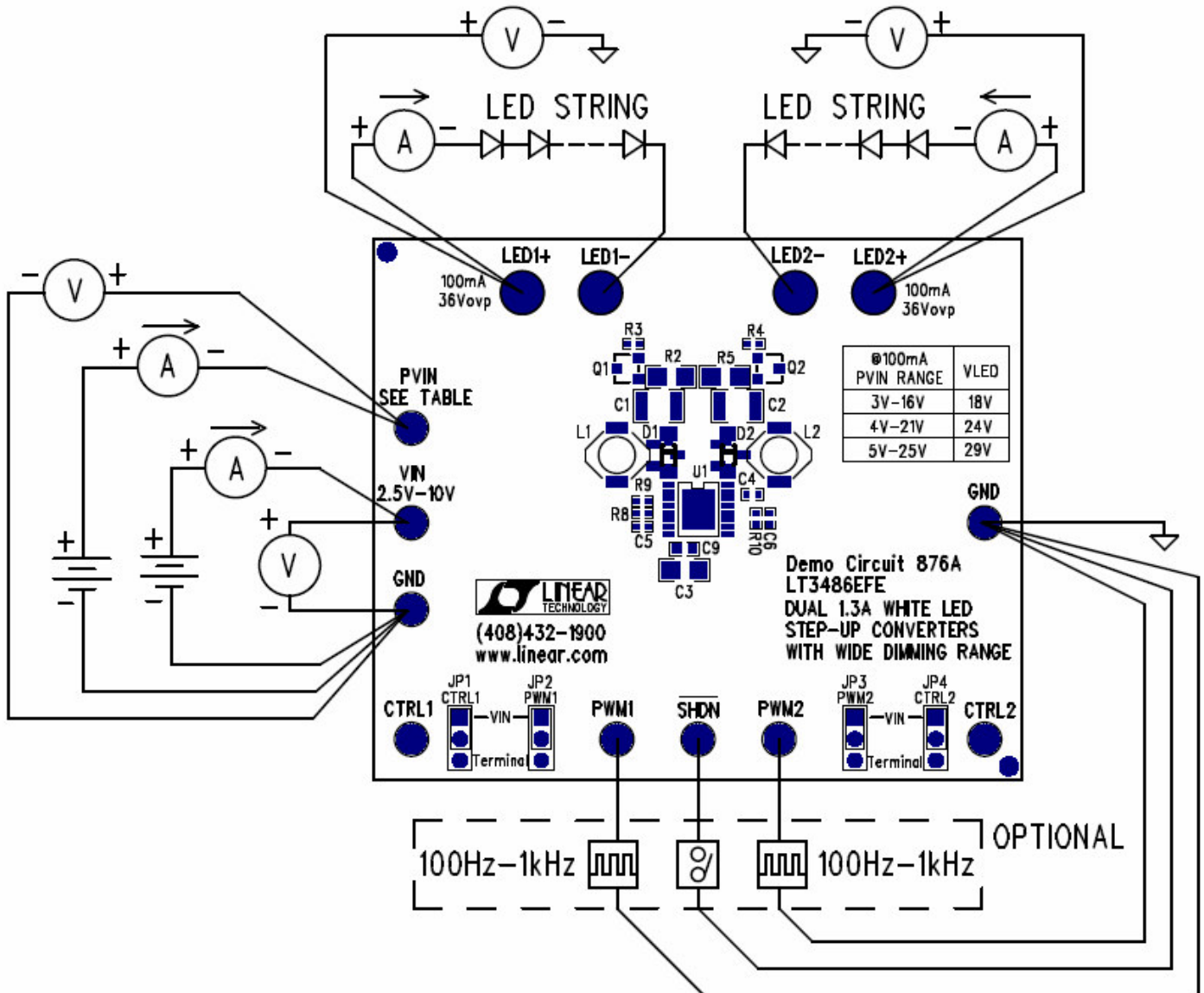
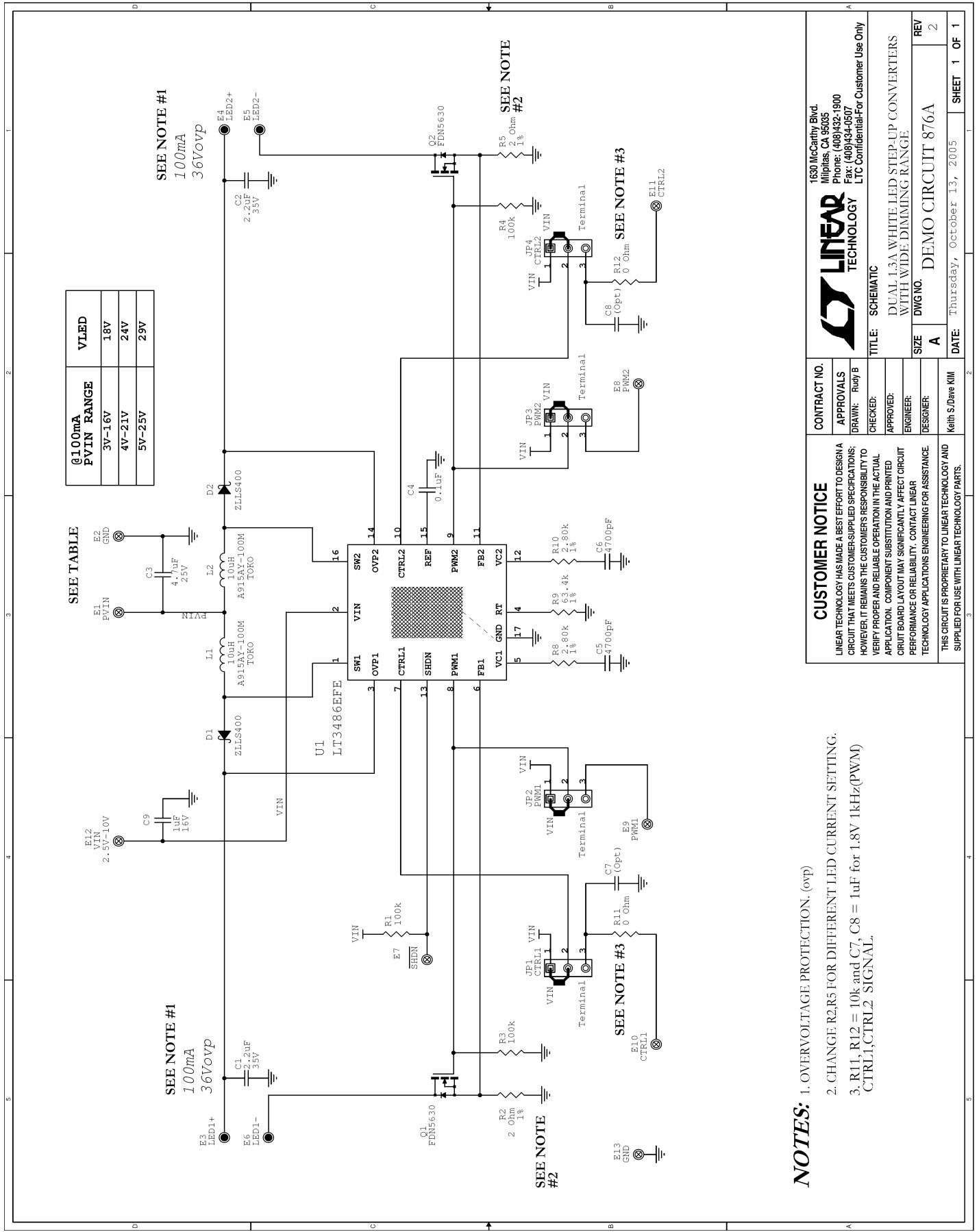

Figure 3. Proper Measurement Equipment Setup

# QUICK START GUIDE FOR DEMONSTRATION CIRCUIT 876

## DUAL 1.3A WHITE LED STEP-UP CONVERTERS WITH WIDE DIMMING RANGE



### NOTES:

1. OVERVOLTAGE PROTECTION. (ovp)
2. CHANGE R2,R5 FOR DIFFERENT LED CURRENT SETTING.
3. R1, R12 = 10k and C7, C8 = 1µF for 1.8V 1kHz(PWM) CTRL1,CTRL2 SIGNAL.

**CUSTOMER NOTICE**  
LINEAR TECHNOLOGY HAS MADE A BEST EFFORT TO DESIGN A CIRCUIT THAT MEETS CUSTOMER-SUPPLIED SPECIFICATIONS; HOWEVER, IT REMAINS THE CUSTOMER'S RESPONSIBILITY TO VERIFY PROPER AND RELIABLE OPERATION IN THE ACTUAL APPLICATION. COMPONENT SUBSTITUTION AND PRINTED CIRCUIT BOARD LAYOUT MAY SIGNIFICANTLY AFFECT CIRCUIT PERFORMANCE OR RELIABILITY. CONTACT LINEAR TECHNOLOGY APPLICATIONS ENGINEERING FOR ASSISTANCE.  
THIS CIRCUIT IS PROPRIETARY TO LINEAR TECHNOLOGY AND SUPPLIED FOR USE WITH LINEAR TECHNOLOGY PARTS.

**CONTRACT NO.**  
**APPROVALS**  
DRAWN: Rudy B  
CHECKED:  
APPROVED:  
ENGINEER:  
DESIGNER:

**LINEAR TECHNOLOGY**  
1630 McCarthy Blvd.  
Milpitas, CA 95055  
Phone: (408)432-1900  
Fax: (408)434-0507  
LTC Confidential-For Customer Use Only

**TITLE:** SCHEMATIC  
**DUAL 1.3A WHITE LED STEP-UP CONVERTERS WITH WIDE DIMMING RANGE.**

**SIZE:** A  
**DWG NO.** DEMO CIRCUIT 876A  
**REV** 2

**DATE:** Thursday, October 13, 2005  
**SHEET** 1 OF 1



Компания «ЭлектроПласт» предлагает заключение долгосрочных отношений при поставках импортных электронных компонентов на взаимовыгодных условиях!

Наши преимущества:

- Оперативные поставки широкого спектра электронных компонентов отечественного и импортного производства напрямую от производителей и с крупнейших мировых складов;
- Поставка более 17-ти миллионов наименований электронных компонентов;
- Поставка сложных, дефицитных, либо снятых с производства позиций;
- Оперативные сроки поставки под заказ (от 5 рабочих дней);
- Экспресс доставка в любую точку России;
- Техническая поддержка проекта, помощь в подборе аналогов, поставка прототипов;
- Система менеджмента качества сертифицирована по Международному стандарту ISO 9001;
- Лицензия ФСБ на осуществление работ с использованием сведений, составляющих государственную тайну;
- Поставка специализированных компонентов (Xilinx, Altera, Analog Devices, Intersil, Interpoint, Microsemi, Aeroflex, Peregrine, Syfer, Eurofarad, Texas Instrument, Miteq, Cobham, E2V, MA-COM, Hittite, Mini-Circuits, General Dynamics и др.);

Помимо этого, одним из направлений компании «ЭлектроПласт» является направление «Источники питания». Мы предлагаем Вам помощь Конструкторского отдела:

- Подбор оптимального решения, техническое обоснование при выборе компонента;
- Подбор аналогов;
- Консультации по применению компонента;
- Поставка образцов и прототипов;
- Техническая поддержка проекта;
- Защита от снятия компонента с производства.



#### Как с нами связаться

**Телефон:** 8 (812) 309 58 32 (многоканальный)

**Факс:** 8 (812) 320-02-42

**Электронная почта:** [org@eplast1.ru](mailto:org@eplast1.ru)

**Адрес:** 198099, г. Санкт-Петербург, ул. Калинина, дом 2, корпус 4, литера А.