

Figure 1

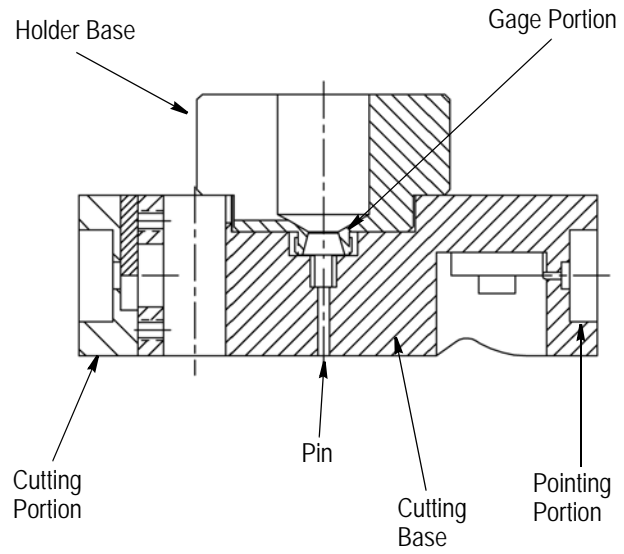

Figure 2

1. INTRODUCTION

(Non-adjustable) Hand Trim and Pointing Tool 1055815-1 was designed to cut the insulation on RG-405/U (0.085-inch) coaxial cable and "point" the center conductor of the stripped coaxial cable.



Dimensions are in metric units [with U.S. customary units in brackets] unless otherwise designated.

Refer to Section 5, REVISION SUMMARY, for updates.

2. DESCRIPTION

This tool is shipped in kit form and consists of the holder base, the cutting base, and the cutter set gage. Refer to Figure 1 and Figure 4. The kit also contains two hex wrenches.

3. OPERATION

1. Seat the holder base onto the gage portion of the cutting base.
2. Insert the cable into the holder base until the cable makes contact with the pin of the gage. See Figure 2.
3. Firmly turn the holder base clockwise to tighten it.
4. Remove the holder base and insert it into the cutting portion of the cutting base.
5. Rotate the holder base clockwise and apply a light axial force to start the cut.

6. Continue rotating the cutting base until you can no longer feel resisting cutting force. (This indicates that the cutting/trimming portion of the operation is complete.)

7. Remove the cutting base from the holder base.

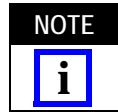

The center conductor should now be exposed.

8. Insert the holder base into the pointing portion of the cutting base.

9. With the cable still in the holder base, turn the cutting base clockwise four or five times while applying axial pressure.

10. Remove holder base from the pointing portion of the cutting base and re-insert it into the gage portion.

11. Turn the holder base approximately 1/2 turn counterclockwise to loosen it.

12. Remove the cable. The cable has now been trimmed and pointed to the dimensions shown in Figure 3.

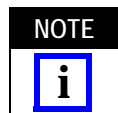

If the length of the cable center conductor is shorter than .065 inches for RG-405/U cable, the tool may not be able to adequately point the cable center conductor.

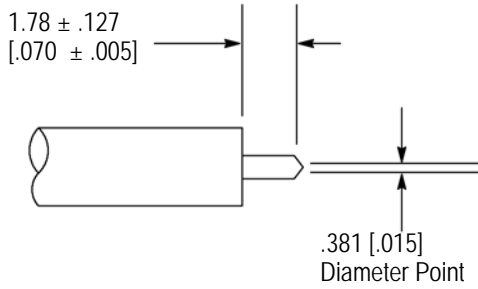

RG-405/U Cable

Figure 3

4. CUTTER ADJUSTMENT OR REPLACEMENT

4.1. Cutter Adjustment

The trim and pointing tool is already adjusted for most kinds of semi-rigid coaxial cable. However, if adjustment becomes necessary, proceed as follows:

1. Assemble the set gage in the holding base, as if it were a cable.

2. Loosen the .050-hex, set screw and retract the cutter slightly.
3. Put holder base/cutting gage assembly into the cutting portion of the cutting base.
4. Push the the cutting blade into the cutter set gage. Then tighten the set screw.

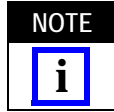

The slight changes in cutting depth are determined by by how hard the cutter is pushed.

4.2. Cutter Replacement

If the pointing cutter becomes dull, remove the holding screw and remove the insert. Reposition the insert so a new cutting edge rests against the tool.

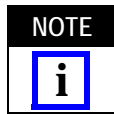

There are six cutting edges per insert.

5. REVISION SUMMARY

Revisions to this instruction sheet include:

- Changed company name and logo

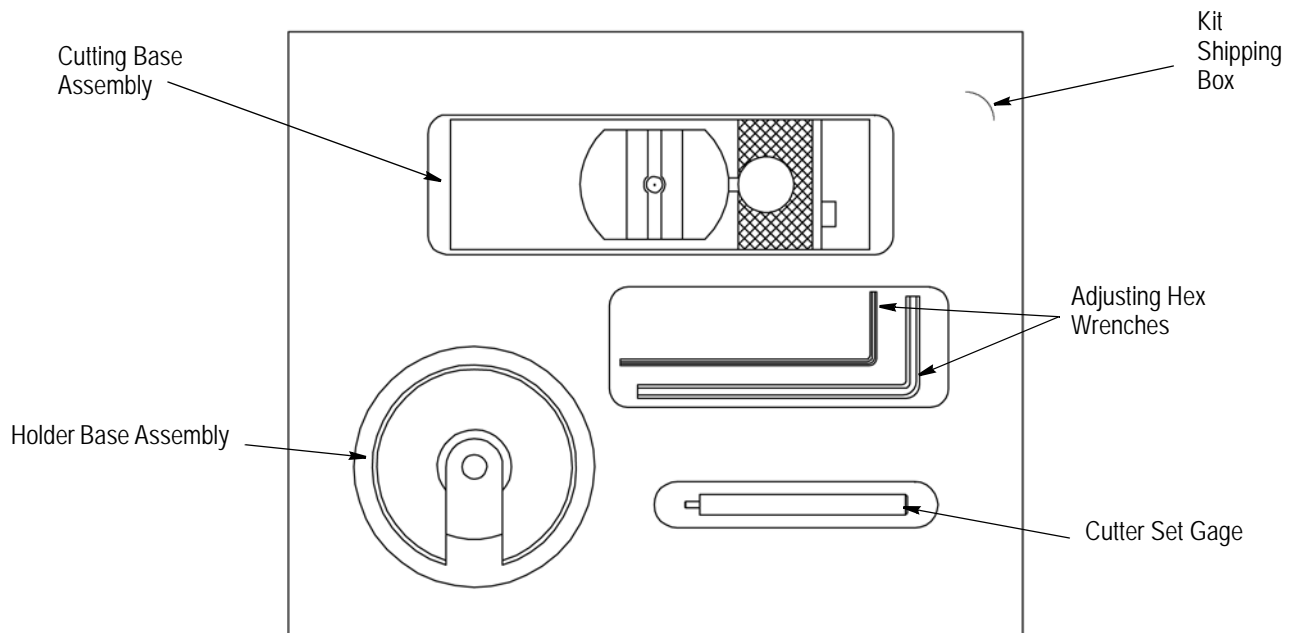

Figure 4



Компания «ЭлектроПласт» предлагает заключение долгосрочных отношений при поставках импортных электронных компонентов на взаимовыгодных условиях!

Наши преимущества:

- Оперативные поставки широкого спектра электронных компонентов отечественного и импортного производства напрямую от производителей и с крупнейших мировых складов;
- Поставка более 17-ти миллионов наименований электронных компонентов;
- Поставка сложных, дефицитных, либо снятых с производства позиций;
- Оперативные сроки поставки под заказ (от 5 рабочих дней);
- Экспресс доставка в любую точку России;
- Техническая поддержка проекта, помощь в подборе аналогов, поставка прототипов;
- Система менеджмента качества сертифицирована по Международному стандарту ISO 9001;
- Лицензия ФСБ на осуществление работ с использованием сведений, составляющих государственную тайну;
- Поставка специализированных компонентов (Xilinx, Altera, Analog Devices, Intersil, Interpoint, Microsemi, Aeroflex, Peregrine, Syfer, Eurofarad, Texas Instrument, Miteq, Cobham, E2V, MA-COM, Hittite, Mini-Circuits, General Dynamics и др.);

Помимо этого, одним из направлений компании «ЭлектроПласт» является направление «Источники питания». Мы предлагаем Вам помощь Конструкторского отдела:

- Подбор оптимального решения, техническое обоснование при выборе компонента;
- Подбор аналогов;
- Консультации по применению компонента;
- Поставка образцов и прототипов;
- Техническая поддержка проекта;
- Защита от снятия компонента с производства.



Как с нами связаться

Телефон: 8 (812) 309 58 32 (многоканальный)

Факс: 8 (812) 320-02-42

Электронная почта: org@eplast1.ru

Адрес: 198099, г. Санкт-Петербург, ул. Калинина, дом 2, корпус 4, литера А.