



NTC thermistors for inrush current limiting

Leaded and coated disks

Series/Type: B57238S0***M0**

Date: October 2011

Applications

- Switch-mode power supplies
- Soft-start motors, e.g. in vacuum cleaners

Features

- Useable in series connections
up to 265 V_{RMS}
- Coated thermistor disk for line applications
- Kinked leads of tinned copper wire
- Wide resistance range
- UL approval (E69802)

Options

Resistance tolerance <20% and alternative lead configurations available on request

Delivery mode

Bulk (standard) or with cardboard tape on 500-mm reel

General technical data

| | | | | | |
|-------------------------------|---------------|---------------------------------|--------------|--|------|
| Climatic category | (IEC 60068-1) | | | | |
| Max. power | (at 25 °C) | P _{max} | 55/170/21 | | |
| Resistance tolerance | | ΔR _R /R _R | ±20 | | W |
| Rated temperature | | T _R | 25 | | °C |
| Dissipation factor | (in air) | δ _{th} | approx. 20 | | mW/K |
| Thermal cooling time constant | (in air) | τ _c | approx. 80 | | s |
| Heat capacity | | C _{th} | approx. 1600 | | mJ/K |

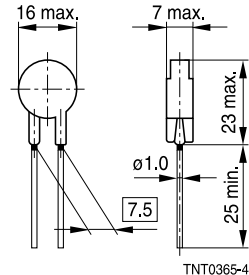
Dimensional drawing

Dimensions in mm
Approx. weight 3 g

Electrical specification and ordering codes

| R ₂₅ | I _{max} (0...65 °C) | B _{25/100} | C _{test} ¹⁾ 230 V AC μF | C _{test} ¹⁾ 110 V AC μF | Param. for R(I) ¹⁾ k | Param. for R(I) ¹⁾ n | Ordering code |
|-----------------|---------------------------------|---------------------|---|---|---------------------------------------|---------------------------------------|-----------------|
| Ω | A | K | | | | | |
| 2.5 | 8.4 | 2800 | 700 | 2800 | 0.984 | -1.36 | B57238S0259M0** |
| 3 | 7.4 | 2900 | 700 | 2800 | 1.04 | -1.36 | B57238S0309M0** |
| 4.7 | 6.6 | 2965 | 700 | 2800 | 1.20 | -1.37 | B57238S0479M0** |
| 5 | 6.4 | 2965 | 700 | 2800 | 1.23 | -1.37 | B57238S0509M0** |
| 7 | 6.0 | 2965 | 700 | 2800 | 1.34 | -1.38 | B57238S0709M0** |
| 8 | 5.5 | 3065 | 700 | 2800 | 1.40 | -1.39 | B57238S0809M0** |
| 10 | 5.0 | 3065 | 700 | 2800 | 1.50 | -1.39 | B57238S0100M0** |
| 15 | 4.4 | 3165 | 700 | 2800 | 1.67 | -1.40 | B57238S0150M0** |
| 16 | 4.0 | 3165 | 700 | 2800 | 1.69 | -1.39 | B57238S0160M0** |

** = Delivery mode

00 = Bulk

51 = Reel packing

1) For details on the capacitance C_{test} as well as on the parameters k and n refer to "Application notes", chapters 1.6 and 1.7.

Reliability data

| Test | Standard | Test conditions | $\Delta R_{25}/R_{25}$ (typical) | Remarks |
|------------------------------------|----------------|--|-------------------------------------|-------------------|
| Storage in dry heat | IEC 60068-2-2 | Storage at upper category temperature T: 170 °C t: 1000 h | < 10% | No visible damage |
| Storage in damp heat, steady state | IEC 60068-2-78 | Temperature of air: 40 °C Relative humidity of air: 93% Duration: 21 days | < 5% | No visible damage |
| Rapid temperature cycling | IEC 60068-2-14 | Lower test temperature: -55 °C Upper test temperature: 170 °C Number of cycles: 10 | < 10% | No visible damage |
| Endurance | | $I = I_{\max}$ t: 1000 h | < 10% | No visible damage |
| Cyclic endurance | | $I = I_{\max}$, 1000 cycles On-time = 1 min Cooling time = 6 min | < 10% | No visible damage |
| Transient load | | Capacitance = C_{test} Number of cycles: 1000 | < 5% | No visible damage |

Note

- The self-heating of a thermistor during operation depends on the load applied and the applicable dissipation factor.
- When loaded with maximum allowable current/power and the specified dissipation factor is taken as a basis, the NTC thermistor may reach a mean temperature of up to 250 °C.
- The heat developed during operation will also be dissipated through the lead wires. So the contact areas, too, may become quite hot at maximum load.
- When mounting NTC thermistors you have to ensure that there is an adequate distance between the thermistor and all parts which are sensitive to heat or combustible.

Taping and packing

1 Taping of radial leaded ICL NTC thermistors according to the specified lead spacing

Dimensions and tolerances

Lead spacing $F = 5.0 \text{ mm}$ (taping to IEC 60286-2)

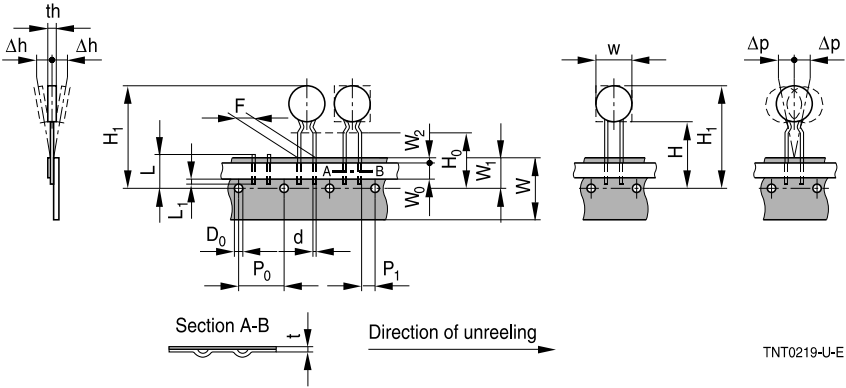

Lead spacing $F = 7.5 \text{ mm}$ (taping based on IEC 60286-2)

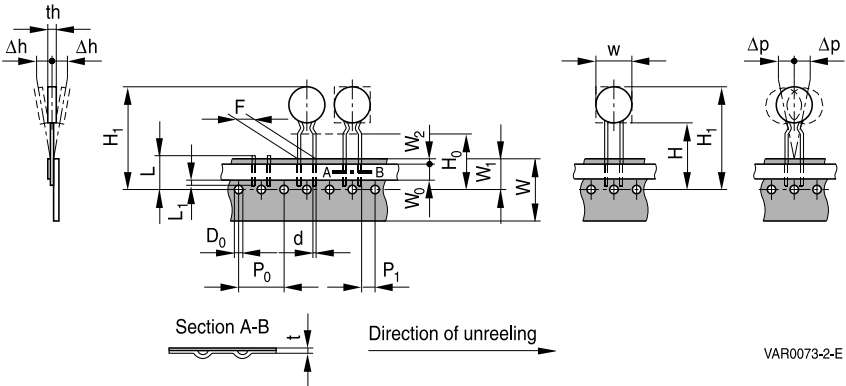

Dimensions (mm)

| | Lead spacing 5 mm | Tolerance of lead spacing 5 mm | Lead spacing 7.5 mm | Tolerance of lead spacing 7.5 mm | Remarks |
|----------------|----------------------|--------------------------------------|------------------------|--|--------------------------------------|
| w | ≤12.0 | max. | ≥12.0 | max. | please refer to dimensional drawings |
| th | 6.0 | max. | 7 | max. | please refer to dimensional drawings |
| d | 0.5/0.6 | ±0.05 | 0.8/1.0 | ±0.05 | please refer to dimensional drawings |
| P ₀ | 12.7 | ±0.3 | 12.7 | ±0.3 | ±1 mm / 20 sprocket holes |
| P ₁ | 3.85 | ±0.7 | 8.95 | ±0.8 | |
| F | 5.0 | +0.6/-0.1 | 7.5 | ±0.8 | |
| Δh | 0 | ±2.0 | 0 | Depends on th | measured at top of component body |
| Δp | 0 | ±1.3 | 0 | ±2.0 | |
| W | 18.0 | ±0.5 | 18.0 | ±0.5 | |
| W ₀ | 5.5 | min. | 11.0 | min. | peel-off force ≥5 N |
| W ₁ | 9.0 | +0.75/-0.5 | 9.0 | +0.75/-0.5 | |
| W ₂ | 3.0 | max. | 3.0 | max. | |
| H | 18.0 | +2.0/-0 | 18.0 | +2.0/-0 | |
| H ₀ | 16.0 | ±0.5 | 16.0 | ±0.5 | |
| H ₁ | 32.2 | max. | 45.0 | max. | |
| D ₀ | 4.0 | ±0.2 | 4.0 | ±0.2 | |
| t | 0.9 | max. | 0.9 | max. | without wires |
| L | 11.0 | max. | 11.0 | max. | |
| L ₁ | 4.0 | max. | 4.0 | max. | |

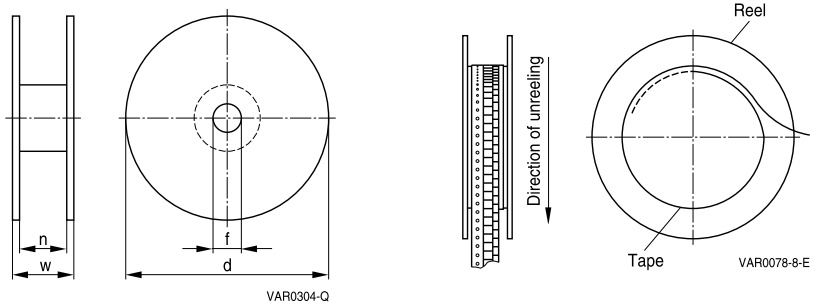
Types of packing
Reel packing

Reel dimensions (in mm)

| Reel type | d | f | n | w |
|-----------|----------|-------|------------|---------|
| I | 360 max. | 31 ±1 | approx. 45 | 54 max. |
| II | 500 max. | 23 ±1 | approx. 59 | 72 max. |

Bulk packing

The components are packed in cardboard boxes, the size of which depends on the order quantity.

Mounting instructions

1 Soldering

1.1 Leaded NTC thermistors

Leaded thermistors comply with the solderability requirements specified by CECC.

When soldering, care must be taken that the NTC thermistors are not damaged by excessive heat. The following maximum temperatures, maximum time spans and minimum distances have to be observed:

| | <i>Dip soldering</i> | <i>Iron soldering</i> |
|--------------------------|----------------------|-----------------------|
| Bath temperature | max. 260 °C | max. 360 °C |
| Soldering time | max. 4 s | max. 2 s |
| Distance from thermistor | min. 6 mm | min. 6 mm |

Under more severe soldering conditions the resistance may change.

Solderability (test to IEC 60068-2-20)

Preconditioning: Immersion into flux F-SW 32.

Evaluation criterion: Wetting of soldering areas $\geq 95\%$.

| Solder | Bath temperature (°C) | Dwell time (s) |
|--------------------------------------|-----------------------|----------------|
| SnAg (3.0 ... 4.0), Cu (0.5 ... 0.9) | 245 \pm 3 | 3 |

1.1.1 Resistance to soldering heat (test to IEC 60068-2-20)

Preconditioning: Immersion into flux F-SW 32.

| Solder | Bath temperature (°C) | Dwell time (s) |
|--------------------------------------|-----------------------|----------------|
| SnAg (3.0 ... 4.0), Cu (0.5 ... 0.9) | 260 –5 | 10 |

Wave soldering

Temperature characteristic at component terminal with dual wave soldering

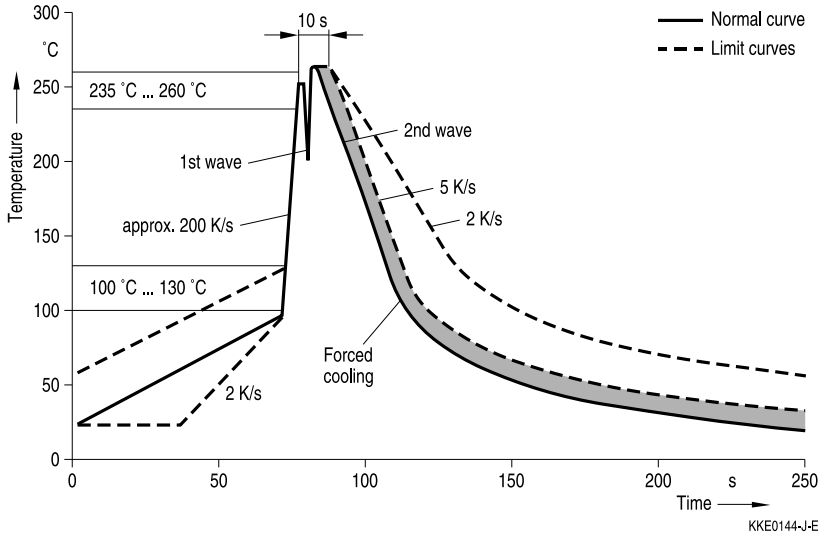

2 Robustness of terminations

The leads meet the requirements of IEC 60068-2-21. They may not be bent closer than 4 mm from the solder joint on the thermistor body or from the point at which they leave the feed-throughs. During bending, any mechanical stress at the outlet of the leads must be removed. The bending radius should be at least 0.75 mm.

Tensile strength: Test Ua1:

Leads $0.50 < \varnothing \leq 0.80 \text{ mm} = 10.0 \text{ N}$
 $0.80 < \varnothing \leq 1.25 \text{ mm} = 20.0 \text{ N}$

Bending strength: Test Ub:

Two 90°-bends in opposite directions at a weight of 0.25 kg.

Torsional strength: Test Uc: severity 2

The lead is bent by 90° at a distance of 6 to 6.5 mm from the thermistor body.

The bending radius of the leads should be approx. 0.75 mm. Two torsions of 180° each (severity 2).

When subjecting leads to mechanical stress, the following should be observed:

Tensile stress on leads

During mounting and operation tensile forces on the leads are to be avoided.

Bending of leads

Bending of the leads directly on the thermistor body is not permissible.

A lead may be bent at a minimum distance of twice the wire's diameter +2 mm from the solder joint on the thermistor body. During bending the wire must be mechanically relieved at its outlet. The bending radius should be at least 0.75 mm.

Twisting of leads

The twisting (torsion) by 180° of a lead bent by 90° is permissible at 6 mm from the bottom of the thermistor body.

3 Sealing and potting

When thermistors are sealed, potted or overmolded, there must be no mechanical stress caused by thermal expansion during the production process (curing / overmolding process) and during later operation. The upper category temperature of the thermistor must not be exceeded. Ensure that the materials used (sealing / potting compound and plastic material) are chemically neutral.

4 Cleaning

If cleaning is necessary, mild cleaning agents such as ethyl alcohol and cleaning gasoline are recommended. Cleaning agents based on water are not allowed. Ultrasonic cleaning methods are permissible.

5 Storage

In order to maintain their solderability, thermistors must be stored in a non-corrosive atmosphere. Humidity, temperature and container materials are critical factors.

The components should be left in the original packing. Touching the metallization of unsoldered thermistors may change their soldering properties.

Storage temperature: $-25\text{ }^{\circ}\text{C}$ up to $45\text{ }^{\circ}\text{C}$

Max. relative humidity (without condensation):
<95%, maximum 30 days per annum

Solder the thermistors listed in this data book after shipment from EPCOS within the time specified:

Leaded components: 24 months

Cautions and warnings

General

See "Important notes" at the end of this document.

Storage

- Store thermistors only in original packaging. Do not open the package before storage.
- Storage conditions in original packaging: storage temperature $-25\text{ °C} \dots +45\text{ °C}$, relative humidity $\leq 75\%$ annual mean, maximum 95%, dew precipitation is inadmissible.
- Avoid contamination of thermistors surface during storage, handling and processing.
- Avoid storage of thermistor in harmful environments like corrosive gases (SO_x , Cl etc).
- Solder thermistors after shipment from EPCOS within the time specified:
 - Leaded components: 24 months

Handling

- NTC thermistors must not be dropped. Chip-offs must not be caused during handling of NTCs.
- Components must not be touched with bare hands. Gloves are recommended.
- Avoid contamination of thermistor surface during handling.
- In case of exposure of the NTC thermistors to water, electrolytes or other aggressive media, these media can penetrate the coating and reach the surface of the ceramic. Low-ohmic or high-ohmic behavior may occur due to the formation of an electrolyte with metals (silver/lead/tin from metallization or solder). Low-ohmic behavior is caused by electrochemical migration, high-ohmic behavior by dissolving of the electrode. In either case, the functionality of the NTC thermistors can not be assured.

Bending / twisting leads

- A lead (wire) may be bent at a minimum distance of twice the wire's diameter plus 4 mm from the component head or housing. When bending ensure the wire is mechanically relieved at the component head or housing. The bending radius should be at least 0.75 mm.
- Twisting (torsion) by 180° of a lead bent by 90° is permissible at 6 mm from the bottom of the thermistor body.

Soldering

- Use resin-type flux or non-activated flux.
- Insufficient preheating may cause ceramic cracks.
- Rapid cooling by dipping in solvent is not recommended.
- Complete removal of flux is recommended.

Mounting

- When NTC thermistors are encapsulated with sealing material or overmolded with plastic material, the precautions given in chapter "Mounting instructions", "Sealing and potting" must be observed.
- Electrode must not be scratched before/during/after the mounting process.
- Contacts and housings used for assembly with thermistor have to be clean before mounting.
- During operation, the inrush current limiters surface temperature can be very high. Ensure that adjacent components are placed at a sufficient distance from the thermistor to allow for proper cooling of the thermistors.
- Ensure that adjacent materials are designed for operation at temperatures comparable to the surface temperature of the thermistor. Be sure that surrounding parts and materials can withstand this temperature.
- Make sure that inrush current limiters are adequately ventilated to avoid overheating.
- Avoid contamination of thermistor surface during processing.

Operation

- Use thermistors only within the specified operating temperature range.
- Use inrush current limiters only within the specified voltage and current ranges.
- Environmental conditions must not harm the thermistors. Use thermistors only in normal atmospheric conditions.
- Contact of NTC thermistors with any liquids and solvents should be prevented. It must be ensured that no water enters the NTC thermistor (e.g. through plug terminals). For measurement purposes (checking the specified resistance vs. temperature), the component must not be immersed in water but in suitable liquids (e.g. Galden).
- In case of exposure of the NTC thermistors to water, electrolytes or other aggressive media, these media can penetrate the coating and reach the surface of the ceramic. Low-ohmic or high-ohmic behavior may occur due to the formation of an electrolyte with metals (silver/lead/tin from metallization or solder). Low-ohmic behavior is caused by electrochemical migration, high-ohmic behavior by dissolving of the electrode. In either case, the functionality of the NTC thermistors cannot be assured.
- Be sure to provide an appropriate fail-safe function to prevent secondary product damage caused by malfunction (e.g. use a metal oxide varistor for limitation of overvoltage condition).

Symbols and terms

| Symbol | English | German |
|------------------------------------|---|--|
| C_{test} | Test capacitance | Prüfkapazität (elektrisch) |
| C_{th} | Heat capacitance | Wärmekapazität |
| I | Current | Strom |
| I_{max} | Maximum current within stated temperature range | Maximalstrom im angegebenen Temperaturbereich |
| I_{NTC} | NTC current | Heißleiter-Strom |
| I_{R} | Rated current | Nennstrom |
| P_{25} | Maximum power at 25 °C | Maximale Leistung bei 25 °C |
| P_{diss} | Power dissipation | Verlustleistung |
| P_{el} | Electrical power | Elektrische Leistung |
| P_{max} | Maximum power within stated temperature range | Maximale Leistung im angegebenen Temperaturbereich |
| R_{R} | Rated resistance | Nennwiderstand |
| $\Delta R_{\text{R}}/R_{\text{R}}$ | Resistance tolerance | Widerstandstoleranz |
| R_{T} | Resistance at temperature T (e.g. R_{25} = resistance at 25 °C) | Widerstand bei Temperatur T (z.B. R_{25} = Widerstand bei 25 °C) |
| T | Temperature | Temperatur |
| t | Time | Zeit |
| T_{A} | Ambient temperature | Umgebungstemperatur |
| t_{a} | Thermal threshold time | Thermische Ansprechzeit |
| T_{max} | Upper category temperature | Obere Grenztemperatur (Kategorietemperatur) |
| T_{min} | Lower category temperature | Untere Grenztemperatur (Kategorietemperatur) |
| T_{R} | Rated temperature | Nenntemperatur |
| V | Voltage | Spannung |
| V_{load} | Load voltage | Ladespannung |
| V_{NTC} | Voltage drop across an NTC thermistor | Spannungsabfall am Heißleiter |
| α | Temperature coefficient | Temperaturkoeffizient |
| Δ | Tolerance, change | Toleranz, Änderung |
| δ_{th} | Dissipation factor | Wärmeleitwert |
| τ_{c} | Thermal cooling time constant | Thermische Abkühlzeitkonstante |

Abbreviations / Notes

| Symbol | English | German |
|--------|--|---|
| * | To be replaced by a number in ordering codes, type designations etc. | Platzhalter für Zahl im Bestellnummerncode oder für die Typenbezeichnung. |
| + | To be replaced by a letter. All dimensions are given in mm. The commas used in numerical values denote decimal points. | Platzhalter für einen Buchstaben. Alle Maße sind in mm angegeben. Verwendete Kommas in Zahlenwerten bezeichnen Dezimalpunkte. |

Important notes

The following applies to all products named in this publication:

1. Some parts of this publication contain **statements about the suitability of our products for certain areas of application**. These statements are based on our knowledge of typical requirements that are often placed on our products in the areas of application concerned. We nevertheless expressly point out **that such statements cannot be regarded as binding statements about the suitability of our products for a particular customer application**. As a rule, EPCOS is either unfamiliar with individual customer applications or less familiar with them than the customers themselves. For these reasons, it is always ultimately incumbent on the customer to check and decide whether an EPCOS product with the properties described in the product specification is suitable for use in a particular customer application.
2. We also point out that **in individual cases, a malfunction of electronic components or failure before the end of their usual service life cannot be completely ruled out in the current state of the art, even if they are operated as specified**. In customer applications requiring a very high level of operational safety and especially in customer applications in which the malfunction or failure of an electronic component could endanger human life or health (e.g. in accident prevention or lifesaving systems), it must therefore be ensured by means of suitable design of the customer application or other action taken by the customer (e.g. installation of protective circuitry or redundancy) that no injury or damage is sustained by third parties in the event of malfunction or failure of an electronic component.
3. **The warnings, cautions and product-specific notes must be observed.**
4. In order to satisfy certain technical requirements, **some of the products described in this publication may contain substances subject to restrictions in certain jurisdictions (e.g. because they are classed as hazardous)**. Useful information on this will be found in our Material Data Sheets on the Internet (www.epcos.com/material). Should you have any more detailed questions, please contact our sales offices.
5. We constantly strive to improve our products. Consequently, **the products described in this publication may change from time to time**. The same is true of the corresponding product specifications. Please check therefore to what extent product descriptions and specifications contained in this publication are still applicable before or when you place an order. We also **reserve the right to discontinue production and delivery of products**. Consequently, we cannot guarantee that all products named in this publication will always be available. The aforementioned does not apply in the case of individual agreements deviating from the foregoing for customer-specific products.
6. Unless otherwise agreed in individual contracts, **all orders are subject to the current version of the "General Terms of Delivery for Products and Services in the Electrical Industry" published by the German Electrical and Electronics Industry Association (ZVEI)**.
7. The trade names EPCOS, BAOKE, Alu-X, CeraDiode, CSMP, CSSP, CTVS, DeltaCap, DigiSiMic, DSSP, FormFit, MiniBlue, MiniCell, MKK, MKD, MLSC, MotorCap, PCC, PhaseCap, PhaseCube, PhaseMod, PhiCap, SIFERRIT, SIFI, SIKOREL, SilverCap, SIMDAD, SiMic, SIMID, SineFormer, SIOV, SIP5D, SIP5K, ThermoFuse, WindCap are **trade-marks registered or pending** in Europe and in other countries. Further information will be found on the Internet at www.epcos.com/trademarks.



Компания «ЭлектроПласт» предлагает заключение долгосрочных отношений при поставках импортных электронных компонентов на взаимовыгодных условиях!

Наши преимущества:

- Оперативные поставки широкого спектра электронных компонентов отечественного и импортного производства напрямую от производителей и с крупнейших мировых складов;
- Поставка более 17-ти миллионов наименований электронных компонентов;
- Поставка сложных, дефицитных, либо снятых с производства позиций;
- Оперативные сроки поставки под заказ (от 5 рабочих дней);
- Экспресс доставка в любую точку России;
- Техническая поддержка проекта, помощь в подборе аналогов, поставка прототипов;
- Система менеджмента качества сертифицирована по Международному стандарту ISO 9001;
- Лицензия ФСБ на осуществление работ с использованием сведений, составляющих государственную тайну;
- Поставка специализированных компонентов (Xilinx, Altera, Analog Devices, Intersil, Interpoint, Microsemi, Aeroflex, Peregrine, Syfer, Eurofarad, Texas Instrument, Miteq, Cobham, E2V, MA-COM, Hittite, Mini-Circuits, General Dynamics и др.);

Помимо этого, одним из направлений компании «ЭлектроПласт» является направление «Источники питания». Мы предлагаем Вам помощь Конструкторского отдела:

- Подбор оптимального решения, техническое обоснование при выборе компонента;
- Подбор аналогов;
- Консультации по применению компонента;
- Поставка образцов и прототипов;
- Техническая поддержка проекта;
- Защита от снятия компонента с производства.



Как с нами связаться

Телефон: 8 (812) 309 58 32 (многоканальный)

Факс: 8 (812) 320-02-42

Электронная почта: org@eplast1.ru

Адрес: 198099, г. Санкт-Петербург, ул. Калинина, дом 2, корпус 4, литера А.