

Features

- RoHS compliant*
- CW or CCW rotary switch
- Linear and audio tapers
- PC board and bushing mount
- Splash seal
- Metal bushing and shaft

Applications

- Test and measurement equipment
- Avionics controls
- Communications equipment
- Medical laboratory equipment

56 - Sealed 1/2 " (12.5 mm) Panel Control w/Rotary Switch

Electrical Characteristics¹

Standard Resistance Range	
Linear	1K to 500K ohms
Audio	1K to 500K ohms
Total Resistance Tolerance	
B & D Tapers	±20 %
E & S Tapers	±10 %
Independent Linearity	±5 %
Absolute Minimum Resistance	2 ohms maximum
Effective Electrical Angle	240 ° ±5
Contact Resistance Variation	±2 %
Dielectric Withstanding Voltage (MIL-STD-202, Method 301)	
Sea Level	1,500 VAC minimum
70,000	500 VAC minimum
Insulation Resistance	1,000 megohms minimum
Power Rating At 70 °C (Derate To 0 At 125 °C)	
(Voltage Limited By Power Dissipation or 350 VAC, Whichever Is Less)	
Linear Tapers	0.5 watt
Audio Tapers	0.25 watt
Theoretical Resolution	Essentially infinite

Environmental Characteristics¹

Operating Temperature Range	+1 °C to +125 °C
Storage Temperature Range	-55 °C to +125 °C
Temperature Coefficient Over Storage Temperature Range	±1,000 ppm/°C
Vibration	8 G
Total Resistance Shift	±2 % maximum
Voltage Ratio Shift	±5 % maximum
Shock	20 G
Total Resistance Shift	±2 % maximum
Voltage Ratio Shift	±5 % maximum
Load Life	1,000 hours
Total Resistance Shift	±10 % TRS maximum
Rotational Life (No Load)	50,000 cycles
Total Resistance Shift	±10 % TRS maximum
Contact Resistance Variation	±2 %
Moisture Resistance (MIL-STD-202, Method 103, Condition B)	
B & E Taper	±10 % TRS
D & S Taper	±20 % TRS
IP Rating	
Entire Unit	IP 64
Shaft/Bushing	IP 65

Mechanical Characteristics

Stop Strength	56 N-cm (5 lb.-in.)
Mechanical Angle	290 ° ±5 °
Torque	
Running/Starting	0.2 to 1.3 N-cm (0.25 to 2.0 oz.-in.)
Mounting (Torque on Bushing)	1.7 to 2.0 N-m (15 to 18 lb.-in.) maximum
Weight	8.5 grams
Terminals	PC pin
Soldering Condition	Recommended hand soldering using Sn95/Ag5 no clean solder, 0.025 " wire diameter. Maximum temperature 399 °C (750 °F) for 3 seconds. No wash process to be used with no clean flux. Part can be wave soldered at 260 °C (500 °F) for 5 seconds, no wash process with no clean flux.
Marking	Manufacturer's trademark, part number, resistance value and date code.
Ganging (Multiple Section Potentiometers)	Inquire for availability, minimum order quantity and price.
Hardware	One lockwasher and one mounting nut is shipped with each potentiometer.

¹At room ambient: +25 °C nominal and 50 % relative humidity nominal, except as noted.

56 - Sealed 1/2 " (12.5 mm) Panel Control w/Rotary Switch

BOURNS®

Initial Electrical Characteristics - Switch

Switch Type	SPDT (Break before make)
Power Rating (Resistive Load)	0.5 A @ 30 VDC
Dielectric Withstanding Voltage (MIL-STD-202, Method 301) Sea Level	1000 VAC minimum
Insulation Resistance	1000 megohms minimum
Contact Resistance	30 milliohms maximum
Contact Bounce	5 milliseconds maximum
Actuation Angle	35 ° maximum
Switch Travel	25 ° maximum
Detent Torque	1.3 N-cm (2.0 oz.-in) nominal

Environmental Characteristics¹

Vibration	8 G
Contact Resistance	30 milliohms maximum
Contact Bounce	0.1 milliseconds maximum
Shock	20 G
Contact Resistance	30 milliohms maximum
Contact Bounce	0.1 milliseconds maximum
Rotational Life @ Rated Power	50,000 cycles
Contact Resistance	100 milliohms maximum
Moisture Resistance (MIL-STD-202, Method 103, Condition B) Contact Resistance	30 milliohms maximum
Insulation Resistance (After 24 Hours @ Room Temperature - 500 VDC)	100 megohms minimum

¹At room ambient: +25 °C nominal and 50 % relative humidity nominal, except as noted.

56 - Sealed 1/2 " (12.5 mm) Panel Control w/Rotary Switch



Product Dimensions

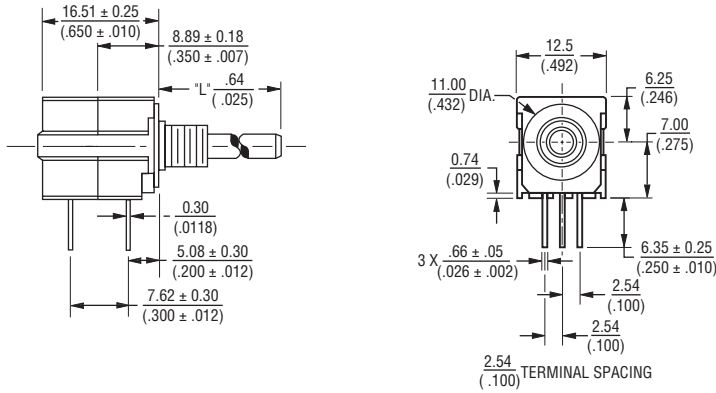

Recommended PCB Layout

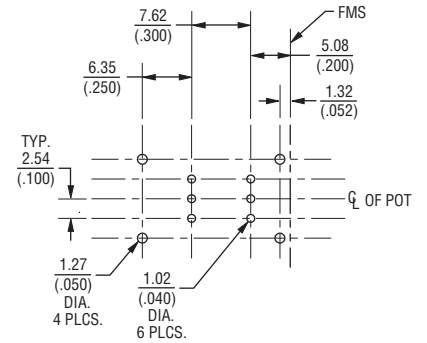

(Double Module Front and Rear Bracket Shown)

Suggested Panel Layouts

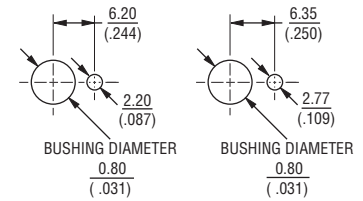

The Model 56 can be used with either of the two panel layouts shown.

Electrical Schematic

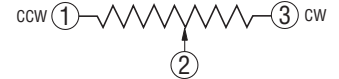

Switch Configuration

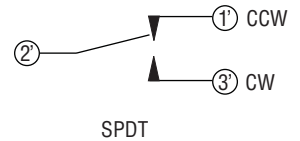

Terminal Layout

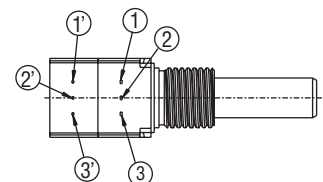

PACKAGE DIMENSIONS W/PCB MOUNTING BRACKET

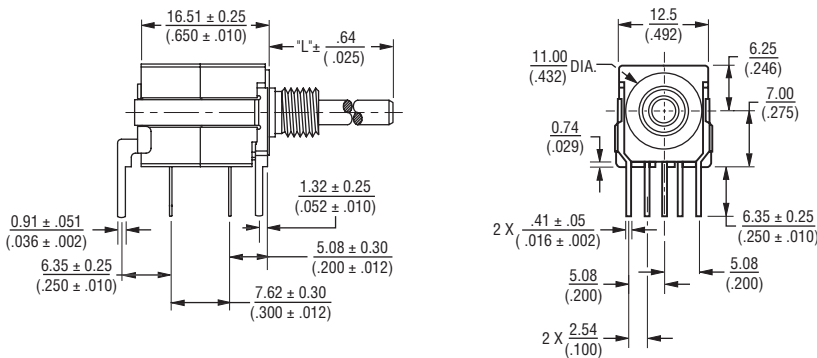

ANTI-ROTATION LUG (Style "A", 90 ° CW Shown)

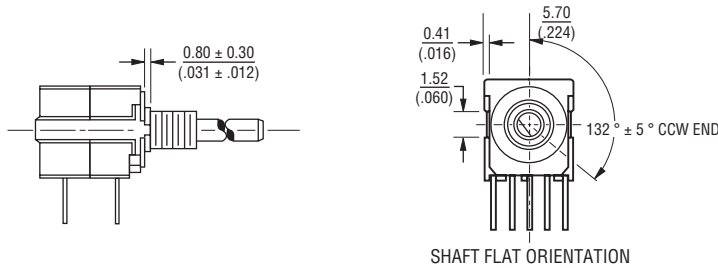

FOR TOLERANCES SHOWN: XX = $\pm \frac{.25}{.010}$
 XXX = $\pm \frac{.13}{.005}$
 SHAFT DIMENSIONS $\pm \frac{.80}{(1/32)}$

DIMENSIONS: $\frac{MM}{(INCHES)}$

56 - Sealed 1/2 " (12.5 mm) Panel Control w/Rotary Switch



Shaft/Bushing Styles

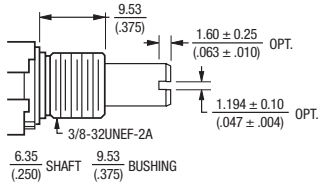

A Style Bushing

STD. LENGTH 'L'
.750 (19.05)
.875 (22.23)

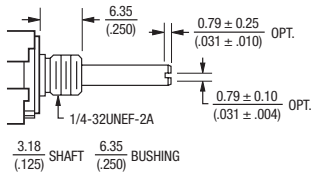

C Style Bushing

STD. LENGTH 'L'
.750 (19.05)
.875 (22.23)

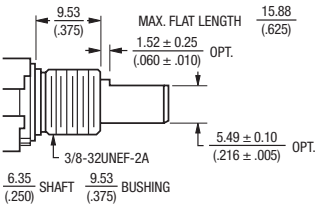

A Style Bushing - Flatted Shaft

STD. LENGTH 'L'
.750 (19.05)
.875 (22.23)

DIMENSIONS: $\frac{\text{MM}}{\text{(INCHES)}}$

How To Order

56 A A D - C 28 - B 15 / R81 L

ANTI-ROTATION LUG / BRACKET OPTION	
Code	Description
A	AR Lug 90 °CW
D	No AR Lug or Bracket
L	Front Bracket
N	Front and Rear Bracket

NO. OF SECTIONS	
Code	Description
A	Single plus Switch

BUSHING DESIGNATOR	
Code	Description
A	3/8 " D x 3/8 " L Threaded
C	1/4 " D x 1/4 " L Threaded

MODEL	
Code	Description
56	PC Terminals w/Rotary Switch

RoHS IDENTIFIER	
Code	Description
L	Compliant

SWITCH OPTION	
Code	Description
R80	SPDT CW
R81	SPDT CCW

RESISTANCE CODES	
Code	Value in Ohms
10	1K
13	5K
15	10K
18	50K
20	100K
22	250K
23	500K

ELEMENT TAPER TYPE/TOLERANCE	
Code	Description
B	Linear CP ±20 %
E	Linear CP ±10 %
D	CW Audio CP ±20 %
S	CW Audio CP ±10 %

SHAFT LENGTH DESIGNATOR	
Code	Description
24	3/4 " FMS Long
28	7/8 " FMS Long

SHAFT STYLE		AVAILABLE ONLY WITH BUSHING
Code	Description	Code
B	1/4 " D Slotted End	A
C	1/4 " D Flatted End	A
E	1/8 " D Slotted End	C

Boldface features are Bourns standard options. All others are available with higher minimum order quantities.



Asia-Pacific: Tel: +886-2 2562-4117 • Fax: +886-2 2562-4116

Europe: Tel: +41-41 768 5555 • Fax: +41-41 768 5510

The Americas: Tel: +1-951 781-5500 • Fax: +1-951 781-5700

www.bourns.com



Компания «ЭлектроПласт» предлагает заключение долгосрочных отношений при поставках импортных электронных компонентов на взаимовыгодных условиях!

Наши преимущества:

- Оперативные поставки широкого спектра электронных компонентов отечественного и импортного производства напрямую от производителей и с крупнейших мировых складов;
- Поставка более 17-ти миллионов наименований электронных компонентов;
- Поставка сложных, дефицитных, либо снятых с производства позиций;
- Оперативные сроки поставки под заказ (от 5 рабочих дней);
- Экспресс доставка в любую точку России;
- Техническая поддержка проекта, помощь в подборе аналогов, поставка прототипов;
- Система менеджмента качества сертифицирована по Международному стандарту ISO 9001;
- Лицензия ФСБ на осуществление работ с использованием сведений, составляющих государственную тайну;
- Поставка специализированных компонентов (Xilinx, Altera, Analog Devices, Intersil, Interpoint, Microsemi, Aeroflex, Peregrine, Syfer, Eurofarad, Texas Instrument, Miteq, Cobham, E2V, MA-COM, Hittite, Mini-Circuits, General Dynamics и др.);

Помимо этого, одним из направлений компании «ЭлектроПласт» является направление «Источники питания». Мы предлагаем Вам помощь Конструкторского отдела:

- Подбор оптимального решения, техническое обоснование при выборе компонента;
- Подбор аналогов;
- Консультации по применению компонента;
- Поставка образцов и прототипов;
- Техническая поддержка проекта;
- Защита от снятия компонента с производства.



Как с нами связаться

Телефон: 8 (812) 309 58 32 (многоканальный)

Факс: 8 (812) 320-02-42

Электронная почта: org@eplast1.ru

Адрес: 198099, г. Санкт-Петербург, ул. Калинина, дом 2, корпус 4, литера А.