

High-Performance FM RDS/RBDS Data Receiver/ Alternate Frequency Scanner

Description

The Si4749 is a 100% CMOS receiver integrated circuit (IC), offering the full receive functionality from antenna to RDS/RBDS* data for use in the automotive and personal navigation markets. It is an ideal companion RDS background data receiver for Traffic Message Channel (TMC) and Open Data Applications (ODA) applications frequently used in conjunction with GPS functionality or as an alternate frequency (AF) scanner in automotive radios. It offers a fully-integrated advanced decoder for the European RDS* and the North American RBDS. It includes demodulation, symbol decoding, advanced error correction, detailed visibility to block-error rates (BLER), and decoder reliability, synchronization status, and times. The Si4749 provides complete, decoded, and error-corrected RDS groups, up to 25 groups at a time with associated BLER.

The Si4749 incorporates a high performance RDS decoder based on patented methodologies, and delivers excellent RDS sensitivity performance, synchronization to RDS at high BLER levels, and RDS data decoding with superior decoder reliability. The Si4749 draws on Silicon Laboratories' broadcast audio and corresponding patent portfolio using a digital low intermediate frequency (low-IF) receiver architecture proven by hundreds of millions broadcast audio receivers shipped worldwide. The low-IF architecture allows the Si4749 to deliver superior performance while integrating the great majority of external components required by competing solutions.

The Si4749 is feature-rich, providing both highly automated performance, according to Silicon Laboratories' recommended settings, or extensive programmability and flexibility for customized system performance. The part accepts programmable reference clock values. The Si4749 offers several modes of operation for various applications which

provide more or less visibility to the RDS status and group data. The Si4749 is offered in a compact 4 x 4 x 0.85 mm 24-pin Quad Flat No-Lead (QFN) package.

***Note:** The term "RDS" will be used to mean "RDS/RBDS" throughout this document.

Features

- Worldwide FM band support (76–108 MHz)
- Advanced patented RDS/RBDS Forward Error Correction (FEC) engine
 - Highest RDS Decoder Reliability
 - Robust synchronization at high BLER
- RDS reception with FM mono broadcast
- Fully configurable RDS data quality visibility and associated interrupts
- On-chip memory for up to 25 RDS groups
- Multi-path interference detection
- Received signal quality indicators (RSSI, SNR, wideband AM)
- Automatic frequency control (AFC)
- Automatic gain control (AGC)
- Image-rejection mixer
- Frequency synthesizer with integrated VCO
- Low-IF direct conversion; no external ceramic filters
- 3.0 to 5.5 V supply voltage
- Programmable reference clock
- AECQ-100 qualified
 - -40 to 85 °C operation
- 24-pin 4 x 4 mm QFN package
 - Pb-free/RoHS compliant

Application

- OEM car audio systems
- After-market car audio systems
- Telematics
- Personal navigation system (PND)
- GPS-enabled devices

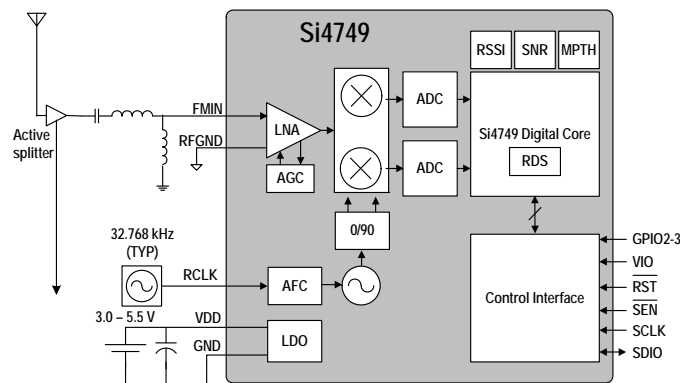

Alternate Frequency Scanner

Selected Electrical Specifications

Parameter	Test Conditions	Min	Typ	Max	Units
Input Frequency		76	—	108	MHz
Frequency Steps		10	—	200	kHz
RDS Sensitivity	$\Delta f = 2$ kHz, RDS BLER < 5%	—	8	—	μ V emf
Input IP3	400 and 800 kHz blockers	—	105	—	dB μ V emf
Image Rejection		—	55	—	dB
Adjacent Channel Selectivity	± 200 kHz	—	50	—	dB
Alternate Channel Selectivity	± 400 kHz	—	70	—	dB
RCLK Frequency		31.13	32.768	40,000	kHz
RCLK Tolerance		-100	—	100	ppm
Supply Voltage		3	—	5.5	V
Interface Supply Voltage		1.5	—	3.6	V
Supply Current		—	24	—	mA
Ambient Temperature		-40	—	85	C
Seek/Tune Time	RCLK tolerance = 100 ppm	—	40	60	ms/channel
Powerup Time	From powerdown	—	—	110	ms

Pin Assignments

Package Information

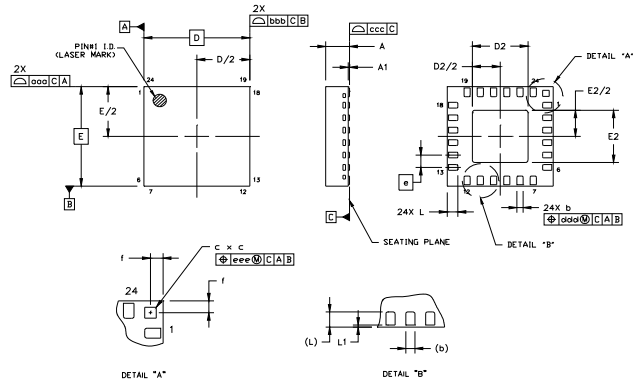
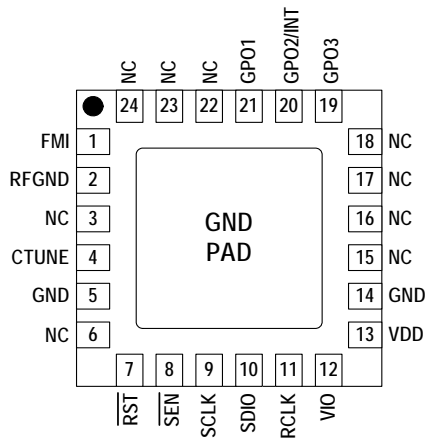

Symbol	Millimeters		
	Min	Nom	Max
A	0.80	0.85	0.90
A1	0.00	0.02	0.05
b	0.18	0.25	0.30
c	0.19	0.24	0.29
D	4.00 BSC		
D2	2.00	2.10	2.20
e	0.50 BSC		
f	0.27 BSC		
E	4.00 BSC		

Symbol	Millimeters		
	Min	Nom	Max
E2	2.00	2.10	2.20
L	0.30	0.40	0.50
L1	0.03	0.05	0.08
aaa	—	—	0.10
bbb	—	—	0.10
ccc	—	—	0.08
ddd	—	—	0.10
eee	—	—	0.10

Notes:

- All dimensions are shown in millimeters unless otherwise noted.
- Dimensioning and tolerancing per ANSI Y14.5M-1994.
- This drawing conforms to the JEDEC Solid State Outline MO-220, Variation VGGD-8.
- Recommended card reflow profile is per the JEDEC/IPC J-STD-020C specification for Small Body Components.
- Lead-free/RoHS compliant.



Smart.
Connected.
Energy-Friendly



Products
www.silabs.com/products



Quality
www.silabs.com/quality



Support and Community
community.silabs.com

Disclaimer

Silicon Laboratories intends to provide customers with the latest, accurate, and in-depth documentation of all peripherals and modules available for system and software implementers using or intending to use the Silicon Laboratories products. Characterization data, available modules and peripherals, memory sizes and memory addresses refer to each specific device, and "Typical" parameters provided can and do vary in different applications. Application examples described herein are for illustrative purposes only. Silicon Laboratories reserves the right to make changes without further notice and limitation to product information, specifications, and descriptions herein, and does not give warranties as to the accuracy or completeness of the included information. Silicon Laboratories shall have no liability for the consequences of use of the information supplied herein. This document does not imply or express copyright licenses granted hereunder to design or fabricate any integrated circuits. The products must not be used within any Life Support System without the specific written consent of Silicon Laboratories. A "Life Support System" is any product or system intended to support or sustain life and/or health, which, if it fails, can be reasonably expected to result in significant personal injury or death. Silicon Laboratories products are generally not intended for military applications. Silicon Laboratories products shall under no circumstances be used in weapons of mass destruction including (but not limited to) nuclear, biological or chemical weapons, or missiles capable of delivering such weapons.

Trademark Information

Silicon Laboratories Inc., Silicon Laboratories, Silicon Labs, SiLabs and the Silicon Labs logo, CMEMS®, EFM, EFM32, EFR, Energy Micro, Energy Micro logo and combinations thereof, "the world's most energy friendly microcontrollers", Ember®, EZLink®, EZMac®, EZRadio®, EZRadioPRO®, DSPLL®, ISOmodem®, Precision32®, ProSLIC®, SiPHY®, USBXpress® and others are trademarks or registered trademarks of Silicon Laboratories Inc. ARM, CORTEX, Cortex-M3 and THUMB are trademarks or registered trademarks of ARM Holdings. Keil is a registered trademark of ARM Limited. All other products or brand names mentioned herein are trademarks of their respective holders.



Silicon Laboratories Inc.
400 West Cesar Chavez
Austin, TX 78701
USA

<http://www.silabs.com>



Компания «ЭлектроПласт» предлагает заключение долгосрочных отношений при поставках импортных электронных компонентов на взаимовыгодных условиях!

Наши преимущества:

- Оперативные поставки широкого спектра электронных компонентов отечественного и импортного производства напрямую от производителей и с крупнейших мировых складов;
- Поставка более 17-ти миллионов наименований электронных компонентов;
- Поставка сложных, дефицитных, либо снятых с производства позиций;
- Оперативные сроки поставки под заказ (от 5 рабочих дней);
- Экспресс доставка в любую точку России;
- Техническая поддержка проекта, помощь в подборе аналогов, поставка прототипов;
- Система менеджмента качества сертифицирована по Международному стандарту ISO 9001;
- Лицензия ФСБ на осуществление работ с использованием сведений, составляющих государственную тайну;
- Поставка специализированных компонентов (Xilinx, Altera, Analog Devices, Intersil, Interpoint, Microsemi, Aeroflex, Peregrine, Syfer, Eurofarad, Texas Instrument, Miteq, Cobham, E2V, MA-COM, Hittite, Mini-Circuits, General Dynamics и др.);

Помимо этого, одним из направлений компании «ЭлектроПласт» является направление «Источники питания». Мы предлагаем Вам помощь Конструкторского отдела:

- Подбор оптимального решения, техническое обоснование при выборе компонента;
- Подбор аналогов;
- Консультации по применению компонента;
- Поставка образцов и прототипов;
- Техническая поддержка проекта;
- Защита от снятия компонента с производства.



Как с нами связаться

Телефон: 8 (812) 309 58 32 (многоканальный)

Факс: 8 (812) 320-02-42

Электронная почта: org@eplast1.ru

Адрес: 198099, г. Санкт-Петербург, ул. Калинина, дом 2, корпус 4, литера А.