

PLC-OS...

PLC INTERFACE With Solid-State Relay, Universal Version

INTERFACE

Data Sheet
103148_en_02

© PHOENIX CONTACT - 03/2008



1 Description

PLC-OS... relay modules, which can be used universally, comprise 6.2 mm basic terminal blocks and plug-in miniature solid-state relays with screw or spring-cage connection.

1.1 Input Voltages From 24 V to 230 V

The PLC-OS... is available on the control side in all common industrial voltages from 24 V to 230 V. A further advantage is the ready-integrated input circuit. It consists of a status indicator and polarity reversal protection function, and ensures that the operating state is displayed clearly, also preventing destruction of the optical electronics should the polarity be accidentally reversed.

1.2 Plug-In Bridges Save Wiring

The PLC INTERFACE module achieves maximum efficiency with the user-friendly FBST plug-in bridge system. The PLC-OS... makes effective use of the bridging options for the A1/A2 connection on the control side and for the power supply at connection 13 on the load side. Especially effective here are the 500 mm long color-insulated continuous plug-in bridges that can easily be cut to the required length and quickly inserted in the bridge shafts. They eliminate the need for complicated and time-consuming loop bridges.

1.3 Additional Advantages

- Switching power of up to 24 V DC/3 A, depending on the type
- IP67-protected fully encapsulated optical electronics
- Available with input or power solid-state relays as an option
- Integrated input circuit
- Solid-state relay can be replaced using an engagement lever
- Wear-resistant switching
- Resistant to vibrations and shocks
- Inflammability class V0 according to UL94



Make sure you always use the latest documentation.
It can be downloaded at www.download.phoenixcontact.com.



A conversion table is available on the Internet at
www.download.phoenixcontact.com/general/7000_en_00.pdf.



This data sheet is valid for all products listed on the following page:



2 Ordering Data

PLC INTERFACE With Screw Connection

Description	Type	Order No.	Pcs./Pck.
PLC INTERFACE With Input Solid-State Relay, Universal Version			
PLC INTERFACE, comprising PLC-BSC... basic terminal block and plug-in miniature solid-state relay (see INTERFACE catalog), for mounting on  . Other input voltages on request.	24 V DC	PLCOSC- 24DC/48DC/100	2966728
	120 V AC/110 V DC	PLCOSC-120UC/48DC/100	2966744
	230 V AC/220 V DC ¹	PLCOSC-230UC/48DC/100	2966757
PLC INTERFACE With Power Solid-State Relay, Universal Version			
PLC INTERFACE, comprising PLC-BSC.../21 basic terminal block and plug-in miniature solid-state relay (see INTERFACE catalog), for mounting on  . Other input voltages on request.	24 V DC	PLCOSC- 24DC/24DC/2	2966634
	120 V AC/110 V DC	PLCOSC-120UC/24DC/2	2966650
	230 V AC/220 V DC ¹	PLCOSC-230UC/24DC/2	2966663

¹ The PLC-ATP BK insulating plate must be installed for voltages greater than 250 V (L1, L2, L3) between the same terminal points on adjacent modules (see "Accessories"). FBST 8-PLC... or FBST 500... is then used for potential bridging.

PLC INTERFACE With Spring-Cage Connection

Description	Type	Order No.	Pcs./Pck.
PLC INTERFACE With Input Solid-State Relay, Universal Version			
PLC INTERFACE, comprising PLC-BSC... basic terminal block and plug-in miniature solid-state relay (see INTERFACE catalog), for mounting on  . Other input voltages on request.	24 V DC	PLCOSP- 24DC/48DC/100	2967549
	120 V AC/110 V DC	PLCOSP-120UC/48DC/100	2967552
	230 V AC/220 V DC ¹	PLCOSP-230UC/48DC/100	2967565
PLC INTERFACE With Power Solid-State Relay, Universal Version			
PLC INTERFACE, comprising PLC-BSC.../21 basic terminal block and plug-in miniature solid-state relay (see INTERFACE catalog), for mounting on  . Other input voltages on request.	24 V DC	PLCOSP- 24DC/24DC/2	2967471
	120 V AC/110 V DC	PLCOSP-120UC/24DC/2	2967484
	230 V AC/220 V DC ¹	PLCOSP-230UC/24DC/2	2967497

¹ The PLC-ATP BK insulating plate must be installed for voltages greater than 250 V (L1, L2, L3) between the same terminal points on adjacent modules (see "Accessories"). FBST 8-PLC... or FBST 500... is then used for potential bridging.



With the 120 V and 230 V modules, an OPT-60DC/... 60 V solid-state relay is normally used due to the input circuit integrated in the basic terminal block.

For the protection of input and output, inductive loads must be dampened with an effective protective circuit.

Accessories

Description	Type	Order No.	Pcs./Pck.
Insulating plate	PLC-ATP BK	2966841	25



The PLC-ATP BK insulating plate should be used in the following cases: always fit at the start and end of a PLC terminal strip for voltages greater than 250 V (L1, L2, L3) between the same terminal points on adjacent modules (FBST 8-PLC... or FBST 500... can be used for potential bridging) and for safe isolation between adjacent modules.

For additional accessories such as power terminal blocks and plug-in bridges, please refer to the INTERFACE catalog or www.phoenixcontact.com.

3 Technical Data

Input Data	PLCOS...48DC/100		PLCOS...24DC/2	
Nominal input voltage ¹	24 V DC	120 V AC/110 V DC 230 V AC/220 V DC	24 V DC	120 V AC/110 V DC 230 V AC/220 V DC
Permissible range (with reference to U_N)	0.8 ... 1.2 x U_N	0.8 ... 1.1 x U_N	0.8 ... 1.2 x U_N	0.8 ... 1.1 x U_N
Switching level				
1 signal ("H")	0.8 x U_N	0.8 x U_N	0.8 x U_N	0.8 x U_N
0 signal ("L")	0.4 x U_N	0.3 x U_N	0.4 x U_N	0.25 x U_N
Typical input current at U_N	8 mA	4 mA	9 mA	4 mA
Typical response time at U_N	20 μ s	6 ms	20 μ s	6 ms
Typical release time at U_N	300 μ s	10 ms	300 μ s	10 ms
Transmission frequency f_{limit}	300 Hz	10 Hz	300 Hz	10 Hz
Input circuit	Yellow LED, protection against polarity reversal, free-wheeling diode	Yellow LED, bridge rectifier	Yellow LED, protection against polarity reversal, free-wheeling diode	Yellow LED, bridge rectifier

¹ The PLC-ATP BK insulating plate must be installed for voltages greater than 250 V (L1, L2, L3) between the same terminal points on adjacent modules (see "Accessories"). FBST 8-PLC... or FBST 500... is then used for potential bridging.

Output Data	PLCOS...48DC/100	PLCOS...24DC/2
Maximum switching voltage	48 V DC	33 V DC
Minimum switching voltage	3 V DC	
Limiting continuous current	100 mA	3 A (see "Derating Curve")
Maximum inrush current	–	15 A (10 ms)
Output configuration	2-wire floating	
Output circuit	Protection against polarity reversal, surge protection	
Voltage drop at maximum limiting continuous current	≤ 1 V	≤ 200 mV

General Data	
Impulse voltage withstand level	2.5 kV, 50 Hz, 1 min.
Ambient temperature range	
Operation	-25°C ... 60°C
Storage/transport	-40°C ... 85°C
Nominal operating mode	100% operating factor
Inflammability class according to UL 94 (housing)	V0
Standards/specifications ¹	IEC 60664, IEC 60664 A, DIN VDE 0110 (basic insulation)
Pollution degree	2
Surge voltage category	III
Mounting position	Any
Mounting	Can be aligned without spacing
Conductor cross-section	
Solid, with screw connection	0.14 mm ² ... 2.5 mm ² (26 - 14 AWG)
Stranded, with screw connection	0.14 mm ² ... 1.5 mm ² (26 - 14 AWG)
Solid, with spring-cage connection	0.2 mm ² ... 2.5 mm ² (24 - 14 AWG)
Stranded, with spring-cage connection	0.2 mm ² ... 1.5 mm ² (24 - 14 AWG)
Stripping length	
Screw connection	10 mm
Spring-cage connection	8 mm
Dimensions (W x H x D)	6.2 mm x 94 mm x 80 mm
Housing material	Polyamide PA, green

¹ The PLC-ATP BK insulating plate must be installed for safe isolation between adjacent modules (see "Accessories"). FBST 8-PLC... or FBST 500... is then used for potential bridging.

Tests/Approvals

CE

CE

UL



GL



4 Block Diagram

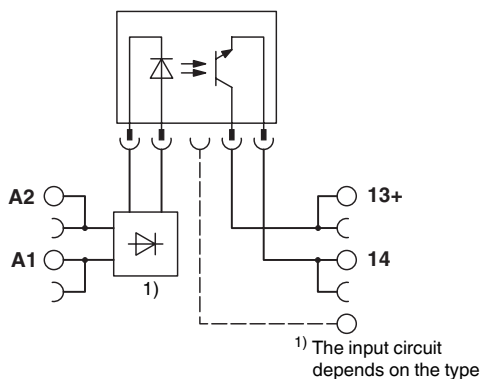

5 Derating Curve

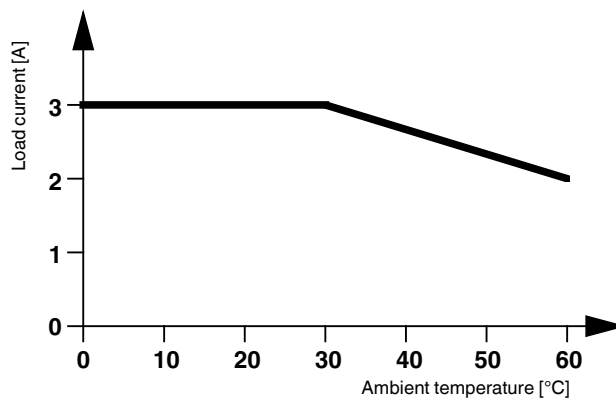



Компания «ЭлектроПласт» предлагает заключение долгосрочных отношений при поставках импортных электронных компонентов на взаимовыгодных условиях!

Наши преимущества:

- Оперативные поставки широкого спектра электронных компонентов отечественного и импортного производства напрямую от производителей и с крупнейших мировых складов;
- Поставка более 17-ти миллионов наименований электронных компонентов;
- Поставка сложных, дефицитных, либо снятых с производства позиций;
- Оперативные сроки поставки под заказ (от 5 рабочих дней);
- Экспресс доставка в любую точку России;
- Техническая поддержка проекта, помощь в подборе аналогов, поставка прототипов;
- Система менеджмента качества сертифицирована по Международному стандарту ISO 9001;
- Лицензия ФСБ на осуществление работ с использованием сведений, составляющих государственную тайну;
- Поставка специализированных компонентов (Xilinx, Altera, Analog Devices, Intersil, Interpoint, Microsemi, Aeroflex, Peregrine, Syfer, Eurofarad, Texas Instrument, Miteq, Cobham, E2V, MA-COM, Hittite, Mini-Circuits, General Dynamics и др.);

Помимо этого, одним из направлений компании «ЭлектроПласт» является направление «Источники питания». Мы предлагаем Вам помощь Конструкторского отдела:

- Подбор оптимального решения, техническое обоснование при выборе компонента;
- Подбор аналогов;
- Консультации по применению компонента;
- Поставка образцов и прототипов;
- Техническая поддержка проекта;
- Защита от снятия компонента с производства.



Как с нами связаться

Телефон: 8 (812) 309 58 32 (многоканальный)

Факс: 8 (812) 320-02-42

Электронная почта: org@eplast1.ru

Адрес: 198099, г. Санкт-Петербург, ул. Калинина, дом 2, корпус 4, литера А.