

# Integrated IR Propane Datasheet

INIR-PR-01, ISSUE 1

Copyright © SGX Sensortech 2012-2019



## Integrated IR FEATURES

- Gas Sensor with **Automatic Switchover** between ranges,
- **High Resolution** up to 10ppm,
- **Detectivity Level** at 100ppm,
- **Multi-sensor mode**,
- Analog Output of gas concentration,
- Serial port communication,
- **Internal Temperature** sensor
- Active & Reference **Signals Monitored**
- Full **Faults Diagnostics & Error Generation**
- Cyclic Redundancy Check (**CRC**)
- **Typical Low power** consumption < 100mW (Average)
- **Factory calibrated** for Propane or Carbon Dioxide
- **Evaluation Kit** available including **PC software** for easy testing and production calibration functions
- Easy implementation into **Sensors Network**
- Design for use in Hazardous Areas
- **Certified Sensor** for use in Explosive Atmospheres (EX)

## GENERAL DESCRIPTION

The Integrated IR (INIR) sensor has been designed with the latest technology, using a microcontroller with an ARM7 core and via software design the necessary techniques have been implemented to increase the reliability of the device therefore minimize the probability of faults.

The INIR is a user friendly digital Gas Sensor, which is designed to use the latest SGX Sensortech's Infrared technology.

The sensor is designed to decrease the implementation time therefore increase productivity. The Integrated IR sensor incorporates the necessary electronics and embedded software to operate from a low voltage DC power supply. The sensor will process the raw signals to output a linear, temperature compensated signal proportional to the gas concentration applied. The output signal is available in digital and analogue forms.

The SGX Sensortech Integrated IR Gas Sensor provides users with a simple method of incorporating an Infrared Sensor into their gas detection instrument which will significantly reduce the development time and expertise required during the design and implementation phase. The Integrated IR can also be factory calibrated to allow installation without the need for recalibration.

## RECOMMENDED APPLICATIONS

- **Automation & Control**
- **Indoor Air Quality**
- **Industrial Health & Safety**

## TECHNICAL SPECS

Whilst SGX Europe Sp. z o.o. has taken care to ensure the accuracy of the information contained herein it accepts no responsibility for the consequences of any use thereof and also reserves the right to change the specification of goods without notice. SGX Europe accepts no liability beyond the set out in its standard conditions of sale in respect of infringement of third party patents arising from the use of tubes or other devices in accordance with information contained herein. In case of modification of the product, SGX disclaims all liability.

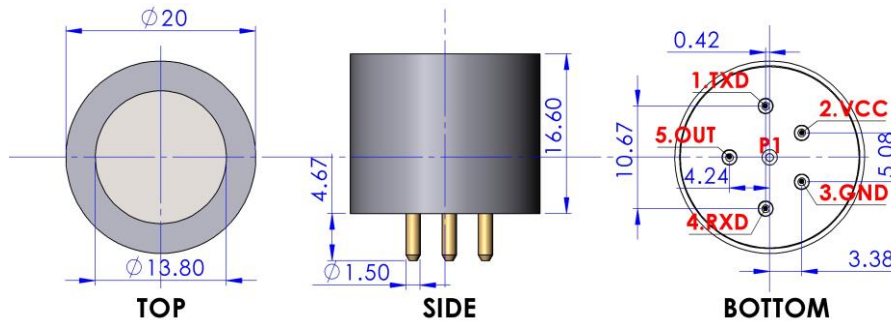

**ABSOLUTE MAXIMUM RATINGS**

Power Supply	Min	Typical	Max
Supply Voltage	3.2 VDC	3.3 VDC	5.25 VDC
Average Current Consumption	30mA	32mA	35 mA*
*Inrush Current can be up to 65mA			
Logic Outputs Level	LOW Voltage Level(VOL) : 0.6V Maximum HIGH Voltage Level(VOH): 2.0V Minimum 1.6mA source current maximum		
Logic Inputs Level	LOW Voltage Level(VINL): 0.4V Maximum HIGH Voltage Level(VINH): 2.0V Minimum		
<b>Humidity</b>			
Operating Humidity	0%	50%	99%
Storage Humidity	0%	50%	90%
Condensation (>100% Humidity)	Sensor’s Detection Limit, Stability & Linearity would be affected, algorithms are implemented to minimize as the effect.		
<b>Temperature</b>			
Operating Temp.	-40 °C	+20 °C	+75 °C
Storage Temp.	-20 °C	+20 °C	+55 °C
Temp. Cycle Limits		0.8°C/min	1.3°C/min
<b>Pressure ( Compensation will be required )</b>			
Operating Pressure	80kPa	-	120kPa
Storage Pressure	80kPa	-	120kPa
<b>Performance</b>			
DAC Resolution	12-Bit at 0.0-2.5 Volts DC Max Scalable according to Gas Conc. Operating Range		
Digital signal format	8 data bits, 1 stop bit, no parity		
Standard baud rate	38400 as default, 115200, 19200, 9600		
<b>Dimensions</b>			
Diameter (D)	19.9mm	20mm	20.1mm
Height (H)	16.50mm	16.60mm	16.70mm
Pins Height (pH)	4.0mm	4.8mm	5.6mm
Body Material	Stainless Steel		
Weight	25 g	29 g	33 g
<b>Gas Sensor Sockets</b>			
S1	5-Pin , Polygon Topology		

Pin	Name	Description
1	TXD	Data transmitted from the Integrated IR.
2	+VCC	3.2 Volts – 5.25 Volts DC input to Integrated IR
3	GND	GND Plane, 0 Volts reference for Integrated IR
4	RXD	Data received by the Integrated IR.
5	OUT	Analog Output. Scalable range, see Application Note 1 Integrated IR Protocol & Calibration for details.
Pad	Pad	Bootloader Pad. Not used by the customer.

**NOTE1:** All Dimensions in mm. All tolerances Linear +/- 0.1mm and Angular 0.5° unless otherwise stated.

**NOTE2:** Do not solder pins. Customer needs to make sure to find the correct “sockets” for the Gas Sensor to firmly “push fit” plug into their instrument so correct electrical connection is achieved, also see handling precautions in [page 2](#).

**PIN CONFIGURATION**

Whilst SGX Europe Sp. z o.o. has taken care to ensure the accuracy of the information contained herein it accepts no responsibility for the consequences of any use thereof and also reserves the right to change the specification of goods without notice. SGX Europe accepts no liability beyond the set out in its standard conditions of sale in respect of infringement of third party patents arising from the use of tubes or other devices in accordance with information contained herein. In case of modification of the product, SGX disclaims all liability.

**DESIGN CONSIDERATIONS & APPLICATIONS**

**Warm-Up Time**

The Warm-Up Time for the INIR sensor is 45 seconds after each power “ON” or every time when we are changing from Configuration to Normal/Engineering Mode. During this time data are not valid. Please read Fault codes in Application Note 1, “Integrated IR Protocol & Calibration”

The Warm-Up time is not including the period that the sensor needs to reach the ambient temperature. The sensor though is capable of producing readings during the Warm-Up but with a much higher error than specifications.

**Calibration**

For calibration process please read the appropriate Application Note 1, “Integrated IR Protocol & Calibration”. For optimum performance please use following cylinders:

INIR-PR2.1% (Propane)
100% Nitrogen for Zero calibration
1.05% C <sub>3</sub> H <sub>8</sub> for High Span Cal.

Always do Zero Calibration first followed by High Span.

**Gas Flow Rate**

For valid evaluation and to keep tests consistent it is recommended to use 450 – 500 cc/min. flow rate to minimize any effects due to pressure variations in the INIR.

**Digital Interface/Communication**

In terms of the Software implementation, we will need a way to read the Digital Output by using a Microcontroller (MCU) or a Personal Computer (PC) is required. The Software with the Evaluation Kit is compatible with Windows Operating System only and at the moment is not possible to read the Analogue output by using the Evaluation Software.

**Faults Monitoring/Error States**

The Error monitoring and Fault generation happens every second transmitted by the UART. Regularly check all the Faults generated from the INIR to ensure errorless communication and rise appropriate alarms depending on the Fault code. For further information on the different Faults and how to translate them, please read the Application Note 1, “Integrated IR Protocol & Calibration”.

**Analogue Output**

The Analogue Output is updated every one second. Analogue voltage is directly related with the Concentration.

**Condensation, Dust & Extreme Conditions**

Using the INIR in extreme environmental conditions may affect its performance. Typically, the module has a high corrosion resistance and temperature compensated linearized output. The INIR implements an Condensation Compensation Algorithm to minimize the effect especially after power “ON”, eliminating the problem with false alarm. The Sensor can withstand multiple thermal shocks that don’t exceed 1.3°C/min temperature slopes. In applications like mining where dust or other particles are present is recommended to use a dust filter firmly attached to the inlet of the INIR Gas Sensor. The filter tends to increase response times T90, T10 and T50 therefore ensure correct installation and evaluation to comply with regulations in your country. If your device is intended to be used in a hazardous environment, please seek advice from a certification body.

**Pressure Compensation**

The INIR will definitely need pressure compensation irrelevant if the pressure is within the operating pressure. Re-Zero the INIR Gas Sensor under operating conditions is recommended; this will minimize the pressure effects, temperature differential effects but will not eliminate the weather effects like extreme wind velocity, rain or lighting.



**CERTIFICATIONS DETAILS**

	ATEX	IECEX
Certificate	Sira 99ATEX1121U	IECEX SIR 04.0031U
Standards	EN 60079-0:2012, IEC 60079-1:2014 Ed. 7	IEC 60079-0:2011 Ed.6, IEC 60079-1:2014-06 Ed.7
Product Marking	II 2G Ex db IIC Gb Ta -40°C to +75°C	Ex db IIC Gb
Special Conditions for Safe Use	<p><b>Power Input:</b> 1.5W Maximum      <b>Ambient temperature range:</b> -40°C to +75°C</p> <p><b>Condition 1:</b> The thermal resistance of the Gas Sensing Heads do not exceed 25K/W. This shall be taken into account when considering its surface temperature and the temperature classification of the equipment into which it is to be incorporated. Tests indicated that an internal ignition increases the temperature of the mesh by further 4.2K (including a 1.2 safety factor).</p> <p><b>Condition 2:</b> The Gas Sensing Heads shall be protected from impact in service. The Gas Sensing Head shall be mounted in a protective enclosure such that an impact of 7 J in accordance with IEC 60079-0:2007 clause 26.4.2 from any direction shall not cause the impact head to make contact with the Sensing Head.</p> <p><b>Condition 3:</b> The Gas Sensing Heads are dust-proof (IP5X) but offers no protection against the ingress of water. Where protection in excess of IP50 is required, then the apparatus into which the Gas Sensing Head is installed shall provide the necessary ingress protection (for example by fitting an external semi-permeable membrane).</p>	
Manufacturing & Certificate Address	SGX Europe sp. z o.o., 40-568 Katowice, 103 Ligocka str., Poland	

**TYPICAL PERFORMANCE DATA**

(All Data are related to a calibrated sensor and conditions: Temperature 20°C, Relative Humidity 10%RH, Pressure 101kPa, 500 to 1000 ml/min Gas Flow, Averaging of 13 values, unless otherwise stated.)

**INTENDED USE**

This device has been designed to be used as component together with instruments to detect flammable gas of certain concentrations.

- 11. Do not use in acid environment or operate under gases containing acid vapours or particles.
- 12. Do not custom modify the sensor.
- 13. Do not clean the sensor with acid.
- 14. Recalibrating the sensor will only void the calibration certificate not the warranty.



**WARRANTY & WARNING**

The WARRANTY for all the INIR Gas Sensors is 2 years from the purchased date based on use according to this document and the INIR Application Note.

Warranty period or any extended warranties would be confirmed with the order confirmation.

The warranty is invalidated if the sensor is used under conditions other than those specified in this datasheet.

In addition, please pay attention to the following conditions as they will void immediately the WARRANTY:

- 1. Do not allow water condensing into the sensor or deep the sensor into water.
- 2. Do not vandalize the sensor.
- 3. Do not change label or cover it with other stickers.
- 4. Do not over voltage or overcurrent the sensor; always observe the correct polarity of the input.
- 5. Do not solder directly onto the pins, pads or the external body of the sensor.
- 6. Do not drop on the floor or hit it with tools.
- 7. Do not open, cut or break sensor apart.
- 8. Do not expose the sensor to high levels of dust.
- 9. Do not expose the sensor to corrosive gases or operate under corrosive environments.
- 10. Do not paint or mark the sensor externally.

**ESD PRECAUTION**

ESD (Electrostatic Discharge) sensitive device. Charged devices and circuit boards can discharge without detection. Although this product features patented or proprietary subjected circuitry, damage may occur on devices subjected to high energy ESD. Therefore, proper ESD precautions should be taken to avoid performance degradation or loss of functionality.

**Warning! Plugging or Unplugging the Sensor while in operation may damage the device beyond repair. Always power down the instrument when performing maintenance.**



**HANDLING PRECAUTIONS**

- A. Do not drop the Integrated IR on the floor as this could cause damage to the pins or internal components.
- B. Avoid mechanical force against pins or sockets. Protect from dust and sprayed acidic particles .
- C. Do not immerse in water or other fluids.
- D. Do not solder the module directly onto a pcb or to wires. Excessive heat could cause damage.



## ROHS COMPLIANCE

Under the EU Directives, compliance testing is necessary for Pb, Cd, Hg, Cr (VI) and Br. The RoHS directive is effective since July 1, 2006. The regulations prohibit the use of these hazardous substances in new products sold after July 2003.



## WEEE DIRECTIVE

WEEE (Waste from Electrical and Electronic Equipment) is a directive that controls how electric and electronic equipment is handled and recycled effective since August 13, 2005. INIR clustered as component and SGX do not need to have a recycling scheme in place but manufacturers may need to ensure WEEE compliance for their systems.



## ATEX/IECEx CERTIFICATIONS

The ATEX directive consists of two EU directives describing what equipment is allowed in an environment with an explosive atmosphere. The Integrated IR is certified for ATEX (Sira 99ATEX1121U) and IECEx (Sira 04.0031U), see page 5 for more details.

II 2G

Ex db IIC Gb

Ta -40°C to +75°C



## Appendix A Ordering Information

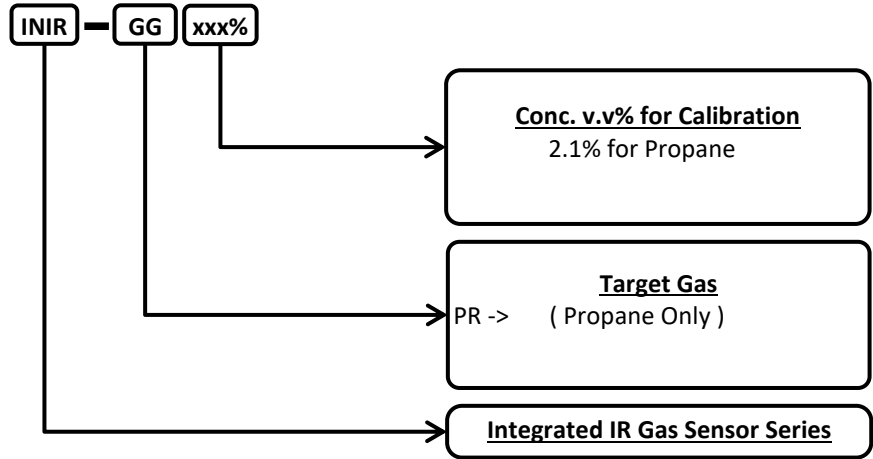

Copyright©2012-2019 SGX Sensortech All rights reserved.

Trademarks and registered trademarks are the property of their respective owners.

No part of this publication may be reproduced, distributed, or transmitted in any form or by any means, including photocopying, recording, or other electronic or mechanical methods, without the prior written permission of the publisher, except in the case of brief quotations embodied in critical reviews and certain other non-commercial uses permitted by copyright law.

For permission requests or technical support please contact or write to the publisher, addressed "Attention: Permissions Coordinator," at the address below:



SGX Europe Sp. z o.o.  
103 Ligocka Str.  
40-568 Katowice  
Poland  
<http://www.sgxsensortech.com>  
Tel. +48 737 759 839  
Author : Grzegorz Konieczny





Компания «ЭлектроПласт» предлагает заключение долгосрочных отношений при поставках импортных электронных компонентов на взаимовыгодных условиях!

Наши преимущества:

- Оперативные поставки широкого спектра электронных компонентов отечественного и импортного производства напрямую от производителей и с крупнейших мировых складов;
- Поставка более 17-ти миллионов наименований электронных компонентов;
- Поставка сложных, дефицитных, либо снятых с производства позиций;
- Оперативные сроки поставки под заказ (от 5 рабочих дней);
- Экспресс доставка в любую точку России;
- Техническая поддержка проекта, помощь в подборе аналогов, поставка прототипов;
- Система менеджмента качества сертифицирована по Международному стандарту ISO 9001;
- Лицензия ФСБ на осуществление работ с использованием сведений, составляющих государственную тайну;
- Поставка специализированных компонентов (Xilinx, Altera, Analog Devices, Intersil, Interpoint, Microsemi, Aeroflex, Peregrine, Syfer, Eurofarad, Texas Instrument, Miteq, Cobham, E2V, MA-COM, Hittite, Mini-Circuits, General Dynamics и др.);

Помимо этого, одним из направлений компании «ЭлектроПласт» является направление «Источники питания». Мы предлагаем Вам помощь Конструкторского отдела:

- Подбор оптимального решения, техническое обоснование при выборе компонента;
- Подбор аналогов;
- Консультации по применению компонента;
- Поставка образцов и прототипов;
- Техническая поддержка проекта;
- Защита от снятия компонента с производства.



#### Как с нами связаться

**Телефон:** 8 (812) 309 58 32 (многоканальный)

**Факс:** 8 (812) 320-02-42

**Электронная почта:** [org@eplast1.ru](mailto:org@eplast1.ru)

**Адрес:** 198099, г. Санкт-Петербург, ул. Калинина, дом 2, корпус 4, литера А.