

Boost (Step-up) WLED Driver with OVP

DESCRIPTION

The TS19371 is a step-up DC/DC converter specifically designed to drive white LEDs with a constant current. The device can drive up to 126 LEDs (9S14P) from a 12V supply. The output capacitor can be as small as 4.7μF, saving space versus alternative solutions. A low 95mV feedback voltage minimizes power loss for better efficiency. Additional features include over output voltage limiting when LEDs are disconnected. The TS19371 switches at a fixed frequency of 1.2MHz, allowing the use of tiny, low profile inductors and capacitors to minimize footprint and cost in space consideration applications for cellular phone backlighting or other hand held equipment.

FEATURES

- Inherently Matched LED Current
- High Efficiency: 89% Typical
- Drives Up to 9 LEDs Series @ Vin 9~15V
- Drives Up to 126 LEDs (9S14P) @ Vin 12~15V
- Drives Up to 6 (1W) LEDs Series @ Vin 12V
- Over Output Voltage Protection 30V
- Fast 1.2MHz Switching Frequency
- Requires Only 4.7μF Output Capacitor
- PWM Dimming Control 1kHz to 10kHz
- Analog Dimming Control
- Compliant to RoHS Directive 2011/65/EU and in accordance to WEEE 2002/96/EC.
- Halogen-Free according to IEC 61249-2-21

APPLICATION

- Cellular Phones
- Portable Electronics Devices PDA, GPS
- LCD Display Module
- White LED Backlighting
- MR-16 Lighting



SOT-26



Pin Definition:

1. SW
2. GND
3. FB
4. CTRL
5. OVP
6. VIN

Notes: MSL 1 (Moisture Sensitivity Level) per J-STD-020

TYPICAL APPLICATION CIRCUIT

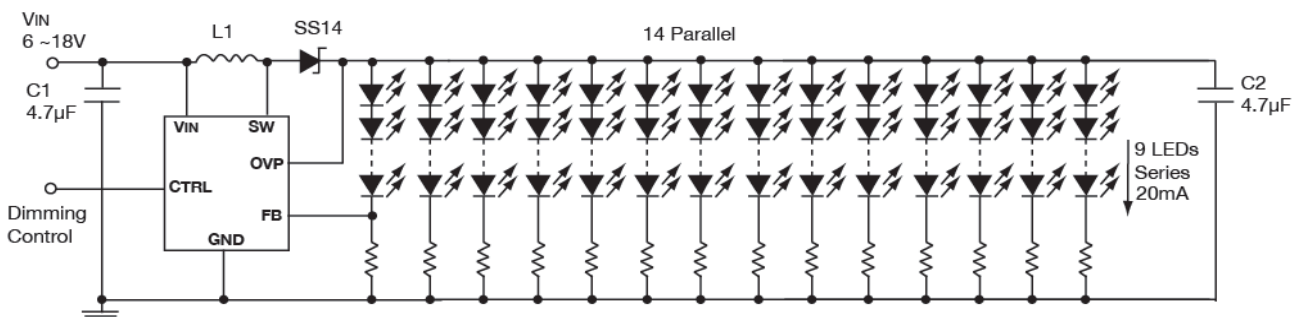

ABSOLUTE MAXIMUM RATINGS ($T_A = 25^\circ\text{C}$ unless otherwise specified) (Note 1)			
PARAMETER	SYMBOL	LIMIT	UNIT
Input Voltage	V_{IN}	20	V
Supply Voltage (Recommended)	V_{IN}	2.5 ~ 18	V
FB Voltage	V_{FB}	10	V
SW Voltage	V_{SW}	36	V
CTRL Voltage	V_{CTRL}	10	V
Ambient Temperature Range	T_A	-40 to +85	$^\circ\text{C}$
Junction Temperature Range	T_J	-40 to +125	$^\circ\text{C}$

THERMAL PERFORMANCE (Note 3)			
PARAMETER	SYMBOL	LIMIT	UNIT
Thermal Resistance Junction to Case	$R_{\theta JC}$	106	$^\circ\text{C/W}$
Thermal Resistance Junction to Ambient	$R_{\theta JA}$	220	$^\circ\text{C/W}$

ELECTRICAL SPECIFICATIONS ($T_A = 25^\circ\text{C}$ unless otherwise specified)						
PARAMETER	SYMBOL	CONDITION	MIN	TYP	MAX	UNIT
Input Voltage Range	V_{IN}		2.5	--	18	V
Feedback Voltage	V_{FB}	$I_{SW}=180\text{mA}, V_{IN}=5\text{V}$	80	95	110	mV
FB Pin Bias Current	I_B		10	45	100	nA
Supply Current	I_Q		--	2.1	3.0	mA
		$C_{TRL}=0\text{V}$	--	0.1	1.0	μA
Switching Frequency	F_{RSW}		0.8	1.2	1.6	MHz
Switch Current Limit	I_{CL}		--	650	--	mA
Maximum Duty Cycle	D_{TMX}		85	90	--	%
Switch V_{CESAT}	V_{SAT}	At $I_{SW}=250\text{mA}$	--	350	--	mV
Switch Leakage Current	I_{LKG}	$V_{SW}=5\text{V}$	--	0.01	5	μA
Voltage Enable Control	V_{CTL}	High	1.5	--	--	V
		Low	--	--	0.4	V
CTRL Pin Bias Current	I_{CTL}	$C_{TRL}=2\text{V}$	--	65	--	μA
Over Voltage Protection	OVP		--	30	--	V

Note:

- Absolute maximum ratings are limits beyond which damage to the device may occur.
- The maximum allowable power dissipation is a function of maximum junction temperature, $T_J(\text{max})$, the junction to ambient thermal resistance, $R_{\theta JA}$, and the ambient temperature. The maximum allowable power dissipation at any ambient temperature is calculated using: $PD(\text{MAX})=[T_J(\text{max})-T_A]/R_{\theta JA}$. Exceeding the maximum allowable power dissipation will cause excessive die temperature. All limits at temperature extremes are guaranteed via correlation using standard statistical methods

ORDERING INFORMATION

PART NO.	PACKAGE	PACKING
TS19371CX6 RFG	SOT-26	3,000pcs / 7"Reel

FUNCTION BLOCK

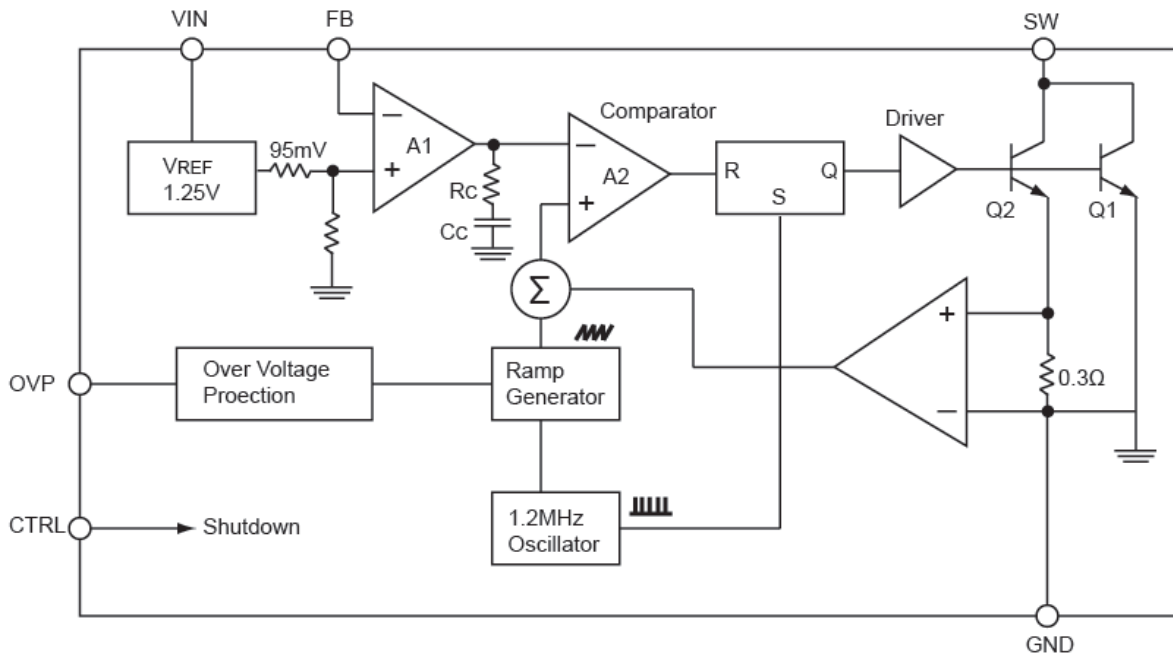

PIN DESCRIPTION

PIN NO.	NAME	FUNCTION
1	SW	Switching Pin. This is the collector of the internal NPN power switch. Connect to inductor and diode. Minimize the metal trace area connected to this pin to reduce EMI.
2	Ground	Ground Pin. Connect directly to local ground plane.
3	FB	Feedback Pin. Reference voltage is 95mV. Connect LEDs and a resistor at this pin. LED current is determined by the resistance and CTRL voltage.
4	CTRL	Shutdown Pin and Dimming Control Pin. $V_{CTRL} > 1.8V$ generates full-scale LED current. $V_{CTRL} < 0.4V$ chip is off. Switching from 0.4V to 2.0V, PWM duty cycle controls the LED current.
5	OVP	Over Voltage Protection, 30V.
6	VIN	Input Supply Pin. Bypass this pin with a capacitor as close to the device as possible.

APPLICATION INFORMATION

Operation

The TS19371 uses a constant frequency, current mode control scheme to provide excellent line and load regulation. Operation can be best understood by referring to the block diagram. At the start of each oscillator cycle, the RS latch is set, which turns on the power switch Q1. A voltage proportional to the switch current is added to a stabilizing ramp and the resulting sum is fed into the positive terminal of the PWM comparator A2. When this voltage exceeds the level at the negative input of A2, the RS latch is reset turning off the power switch. The level at the negative input of A2 is set by the error amplifier A1, and is simply an amplified version of the difference between the feedback voltage and the reference voltage of 95mV. In this manner, the error amplifier sets the correct peak current level to keep the output in regulation. If the error amplifier's output increases, more current is delivered to the output; if it decreases, less current is delivered.

Soft Start and Current Limit

The internal soft start circuit minimizes the inrush current during turning on TS19371. The Typical switch current is limited to about 650mA by the chip.

Over Voltage Protection

The TS19371 has design an internal latched off open-circuit protection circuit, the additional sense pin to detect the voltage when the LEDs are disconnected from the circuit or fail open, the TS19371 will shutdown until input condition changes to bring it out of the shutdown mode.

Inductor Selection

A 10μH inductor is recommended for most TS19371 applications. Although small size and high efficiency are major concerns, the inductor should have low core losses at 1.2MHz and low DCR (copper wire resistance).

Diode Selection

Schottky diodes, with their low forward voltage drop and fast reverse recovery, are the ideal choices for TS19371 applications. The forward voltage drop of a Schottky diode represents the conduction losses in the diode while the diode capacitance (CT or CD) represents the switching losses. For diode selection, both forward voltage drop and diode capacitance need to be considered. Schottky diodes with higher current ratings usually have lower forward voltage drop and larger diode capacitance, which can cause significant switching losses at the 1.2MHz switching frequency of the TS19371. A Schottky diode rated at 1000mA is sufficient for most TS19371 applications.

Capacitor Selection

The small size of ceramic capacitors makes them ideal for TS19371 applications. X5R and X7R types are recommended because they retain their capacitance over wider voltage and temperature ranges than other types such as Y5V or Z5U. A 4.7μF input capacitor and a 4.7μF output capacitor are sufficient for most TS19371 applications.

LED Current Control

The LED current is controlled by the feedback resistor (R1). The feedback reference is 95mV. The LED current is $95\text{mV}/R1$. The formula and table 3 for R1 selection are shown below. $R1=95\text{mV}/I_{\text{LED}}$

I_{LED} (mA)	R1(Ω)
5	19.1
10	9.53
12	7.87
15	6.34
20	4.75

APPLICATION INFORMATION (CONTINUE)

Typical Application Circuit

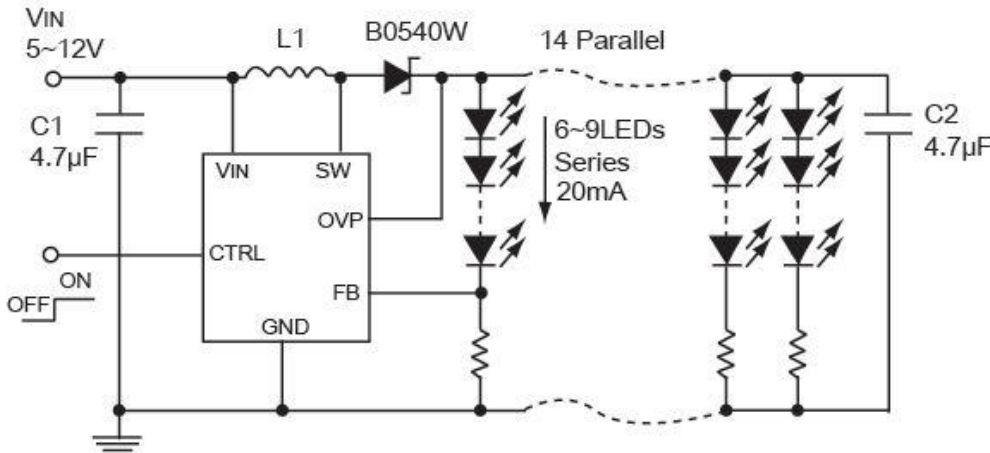

Reference Design Information

VIN Range (V)	VLED (V)	L (µH)	LED (Series)	LED (Parallel)	Current (Series/mA)	Resistor (Ω)	Efficiency (%)
5	19.8	22	6pcs	14	20	4.75	81.2
9	29.7	33	9pcs	14	20	4.75	83.6
12	29.7	47	9pcs	14	20	4.75	87.2
15	29.7	68	9pcs	14	20	4.75	88.4

Typical Application Circuit for 1W x 6pcs LEDs

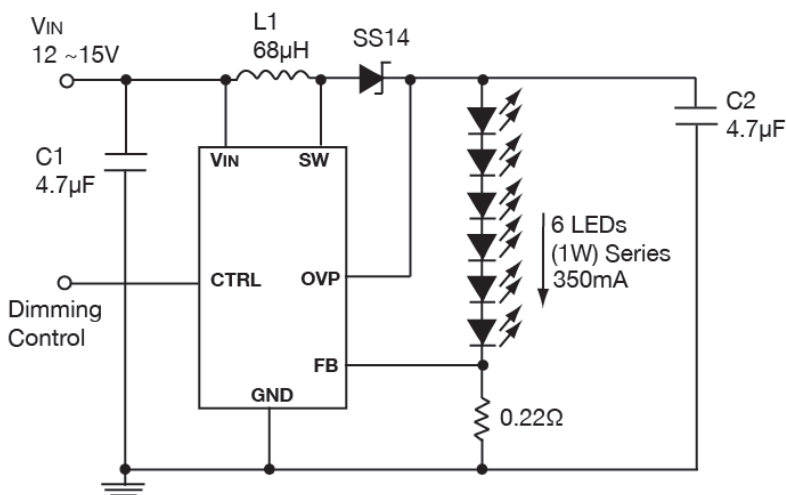

Reference Design Information

VIN Range (V)	VLED. (V)	L (µH)	1W LED (Series)	Current (mA)	Resistor (Ω)	Efficiency (%)
12~15	19.8	68	6pcs	350	0.22	88

APPLICATION INFORMATION (CONTINUE)

LED Dimming Control

There are some different types of dimming control circuits:

1. Using a PWM Signal to CTRL Pin

With the PWM signal applied to the CTRL pin, the TS19371 is turned on or off by the PWM signal. The LEDs operate at either zero or full current. The average LED current increases proportionally with the duty cycle of the PWM signal. A 0% duty cycle will turn off the TS19371 and corresponds to zero LED current. A 100% duty cycle corresponds to full current. The typical frequency range of the PWM signal is 1kHz to 10kHz.

The magnitude of the PWM signal should be higher than the minimum V_{CTRL} high.

For some applications, the preferred method of brightness control is a variable DC voltage to adjust the LED current. The dimming control using a DC voltage is shown in below figure. As the DC voltage increases, the voltage drop on R2 increases and the voltage drop on R1 decreases. Thus, the LED current decreases. The selection of R2 and R3 will make the current from the variable DC source much smaller than the LED current and much larger than the FB pin bias current. For VDC range from 0V to 2V, the selection of resistors in Figure 4 gives dimming control of LED current from 0mA to 20mA.

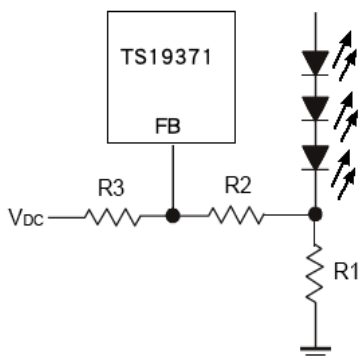

Dimming Control using a DC Voltage

V _{DC} (V)	V _{FB}	I _{OUT} (mA)
2	0	0
1.8	2.2	0.43
1.6	9.2	1.8
1.4	19.6	3.6
1.2	31.1	6
1	43.4	8.5
0.8	63	12.3
0.6	74	14.5
0.4	86.4	16.9
0.2	96.9	19
0	102	20

2. Using a Filtered PWM Signal

The filtered PWM signal can be considered as an adjustable DC voltage. It can be used to replace the variable DC voltage source in dimming control. The circuit is shown as follow:

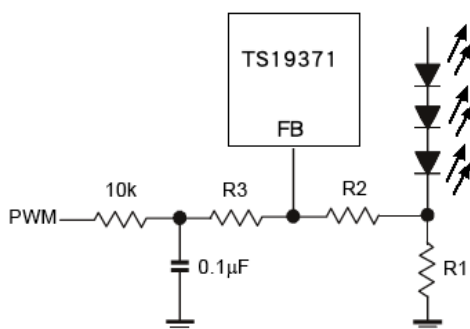

Dimming Control using a Filtered PWM Signal

Duty	I _{OUT} (mA)
0%	20
20%	17.4
30%	15
40%	12.4
50%	10
60%	8
70%	6.4
80%	4.07
100%	0

PWM : 2V ; 1kHz ; Vin=3.6V

3. Using Control pin for dimming

The PWM signal can be considered as TTL signal to control pin to change the power on/off time.

PACKAGE OUTLINE DIMENSIONS (Unit: Millimeters)

SOT-26

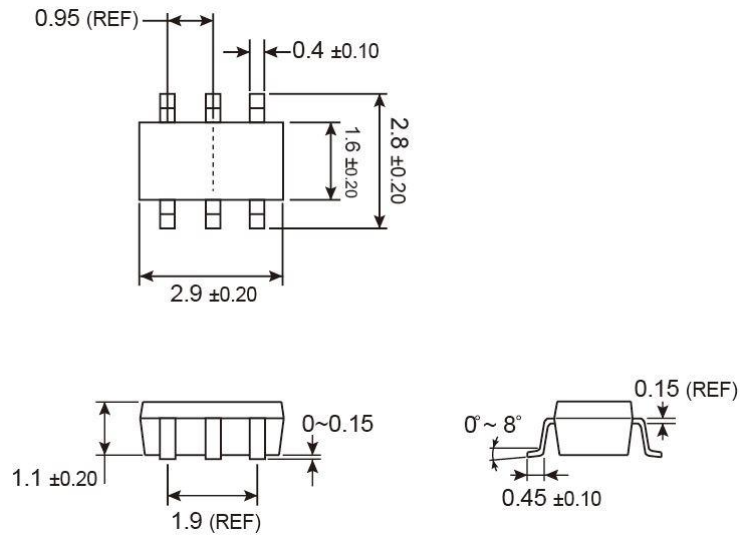

SUGGESTED PAD LAYOUT (Unit: Millimeters)

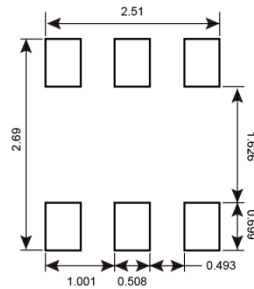

MARKING DIAGRAM

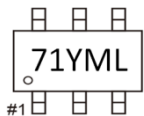

- 71** = Device Code
- Y** = Year Code
- M** = Month Code for Halogen Free Product
 - O** =Jan **P** =Feb **Q** =Mar **R** =Apr
 - S** =May **T** =Jun **U** =Jul **V** =Aug
 - W** =Sep **X** =Oct **Y** =Nov **Z** =Dec
- L** = Lot Code

Notice

Specifications of the products displayed herein are subject to change without notice. TSC or anyone on its behalf, assumes no responsibility or liability for any errors or inaccuracies.

Information contained herein is intended to provide a product description only. No license, express or implied, to any intellectual property rights is granted by this document. Except as provided in TSC's terms and conditions of sale for such products, TSC assumes no liability whatsoever, and disclaims any express or implied warranty, relating to sale and/or use of TSC products including liability or warranties relating to fitness for a particular purpose, merchantability, or infringement of any patent, copyright, or other intellectual property right.

The products shown herein are not designed for use in medical, life-saving, or life-sustaining applications. Customers using or selling these products for use in such applications do so at their own risk and agree to fully indemnify TSC for any damages resulting from such improper use or sale.



Компания «ЭлектроПласт» предлагает заключение долгосрочных отношений при поставках импортных электронных компонентов на взаимовыгодных условиях!

Наши преимущества:

- Оперативные поставки широкого спектра электронных компонентов отечественного и импортного производства напрямую от производителей и с крупнейших мировых складов;
- Поставка более 17-ти миллионов наименований электронных компонентов;
- Поставка сложных, дефицитных, либо снятых с производства позиций;
- Оперативные сроки поставки под заказ (от 5 рабочих дней);
- Экспресс доставка в любую точку России;
- Техническая поддержка проекта, помощь в подборе аналогов, поставка прототипов;
- Система менеджмента качества сертифицирована по Международному стандарту ISO 9001;
- Лицензия ФСБ на осуществление работ с использованием сведений, составляющих государственную тайну;
- Поставка специализированных компонентов (Xilinx, Altera, Analog Devices, Intersil, Interpoint, Microsemi, Aeroflex, Peregrine, Syfer, Eurofarad, Texas Instrument, Miteq, Cobham, E2V, MA-COM, Hittite, Mini-Circuits, General Dynamics и др.);

Помимо этого, одним из направлений компании «ЭлектроПласт» является направление «Источники питания». Мы предлагаем Вам помощь Конструкторского отдела:

- Подбор оптимального решения, техническое обоснование при выборе компонента;
- Подбор аналогов;
- Консультации по применению компонента;
- Поставка образцов и прототипов;
- Техническая поддержка проекта;
- Защита от снятия компонента с производства.



Как с нами связаться

Телефон: 8 (812) 309 58 32 (многоканальный)

Факс: 8 (812) 320-02-42

Электронная почта: org@eplast1.ru

Адрес: 198099, г. Санкт-Петербург, ул. Калинина, дом 2, корпус 4, литера А.