

10115091 - X 0 E - X X X L F

8-COLUMN DIFFERENTIAL SIGNAL

LEAD-FREE DESIGNATION ONLY WITH APPLICABLE PLATING CODES

LETTER	PLATING (SEE NOTE 6)	
	APPLICATION	TYPE (REFERENCE)
B	TELCORDIA CO	0.76um GOLD or GXT
C	TELCORDIA UE	1.27um GOLD
D	TELCORDIA CO	0.76um GOLD or GXT, LEAD-FREE
E	TELCORDIA UE	1.27um GOLD, LEAD-FREE

NUMBER	GUIDE PIN STYLE (SEE NOTE 8)
0	STANDARD GUIDE PIN, MACHINED
1	STANDARD GUIDE PIN, ROLLED

MODULE DESCRIPTION	LETTER DESIGNATION REPRESENTED IN DASH NUMBER										BASE MODULE
LEFT POLARIZING GUIDANCE MODULE (SEE SHEET 6)	N	J	A	B	C	D	E	F	G	H	
	NO KEY NO GUIDE PIN										
RIGHT POLARIZING GUIDANCE MODULE (SEE SHEET 7)	Z	Y	P	Q	R	S	T	U	V	W	
	NO KEY NO GUIDE PIN										
OPEN MODULE (TWO WALL) (SEE SHEET 2)	0 (ZERO)										
LEFT WALL MODULE (SEE SHEET 3)	L										
RIGHT WALL MODULE (SEE SHEET 4)	M										
FOUR WALL MODULE (SEE SHEET 5)	1 (ONE)										

NUMBER	CONTACT MATING WIPE LENGTH		COMPLIANT TAIL TYPE (SEE NOTE 9)
	SIGNAL	GROUND	
1	2 MM	4 MM	0.55 (0.0217") DRILL
2	3 MM	4 MM	0.55 (0.0217") DRILL
3	2 MM	4 MM	0.45 MICRO (0.0177") DRILL
4	3 MM	4 MM	0.45 MICRO (0.0177") DRILL
5	2 MM	3 MM	0.55 (0.0217") DRILL
6	3 MM	3 MM	0.55 (0.0217") DRILL
7	2 MM	3 MM	0.45 MICRO (0.0177") DRILL
8	3 MM	3 MM	0.45 MICRO (0.0177") DRILL

FOR CUSTOM-LOADED MODULES, SEE INDIVIDUAL CUSTOM DRAWINGS WITH THE DRAWING-NUMBER FORMAT OF 10115091-XXXX, WHERE: "X" DENOTES MODULE TYPE PER CHART ON THIS SHEET "YYYY" IS A SEQUENTIAL NUMBER BEGINNING WITH "0001".

	UNGROUND	GROUND
FHS	Ø2.35-Ø2.55	Ø2.35-Ø2.55
PAD	N/A	Ø5.50
PLATED	NO	YES
DRILL (mm)	2.44mm	2.58mm
DRILL (in)	0.096"	0.1015"

SCREW P/N	DESCRIPTION	BOARD THICKNESS
10091790-002LF	#2-56 X 0.375" LG. PHILIPS PANHEAD W/SQ CONICAL WASHER	1.60-5.00mm
10091790-003LF	#2-56 X 0.375" LG. PHILIPS PANHEAD W/SQ CONICAL WASHER	5.00-10.00mm

spec ref	tolerance std	TOLERANCES UNLESS OTHERWISE SPECIFIED		
	ISO 406	0.X	±0.3	
	ISO 1101	0.XX	±0.10	
		0.XXX	±0.05	
	ISO 1302	angular	0°	±2°

dr Collins Lu	2011/07/27	projection	mm	size	A2	scale	1:1
eng Sandar Soe	2016/03/07		←→	ecn no	ELX-S-17624-1		
chr -	-			rel level	Released		
appr Chen-Hong Tan	2016/03/17	product family	-	cat. no.	Product - Customer Drw	sheet 1 of 8	rev
<b>Amphenol FCI</b>		MODULE ASSEMBLY, XCEDE HD		10115091		<b>E</b>	
www.fci.com		Vertical Header, 4 Pair 8 Column					

Amphenol FCI

© 2016 AFCI



SEE DETAIL A  
On Sheet 8 For Details

BP HOLE PATTERN COMPONENT SIDE  
OPEN WALL MODULE BACKPLANE FOOTPRINT



(6.4)  
For 4MM Wipe Ground  
(5.4)  
For 3MM Wipe Ground

(5.2)  
For 3MM Wipe Signal  
(4.2)  
For 2MM Wipe Signal



spec ref	-	dr	Collins Lu	2011/07/27	projection	mm	size	A2	scale	1:1			
tolerance std	ISO 406 ISO 1101	eng	Sandar Soe	2016/03/07		mm	ecn no	ELX-S-17624-1	rel level	Released			
TOLERANCES UNLESS OTHERWISE SPECIFIED		chr	-	appr							Chen-Hong Tan	2016/03/17	product family
surface	ISO 1302	linear	0.X	±0.3			title	MODULE ASSEMBLY, XCEDE HD		dwg no	10115091	rev	E
		angular	0°	±2°	www.fci.com	cat. no.	-	Product - Customer Drw	sheet 2 of 8				

Amphenol  
FCI

© 2016 APCI



LEFT WALL MODULE



SEE DETAIL A  
On Sheet 8 For Details



BP HOLE PATTERN COMPONENT SIDE  
LEFT WALL MODULE BACKPLANE FOOTPRINT

Amphenol  
FCi

© 2016 AFci

spec ref	-	dr	Collins Lu	2011/07/27	projection	mm	size	A2	scale	1:1
tolerance std	ISO 406 ISO 1101	eng	Sandar Soe	2016/03/07		mm	ecn no	ELX-S-17624-1	rel level	Released
TOLERANCES UNLESS OTHERWISE SPECIFIED		chr	-	appr						
surface	ISO 1302	linear	0.X	±0.3			<b>MODULE ASSEMBLY, XCEDE HD</b> Vertical Header, 4 Pair 8 Column		dwg no 10115091	rev E
		angular	0°	±2°	<a href="http://www.fci.com">www.fci.com</a>		cat. no.	-	Product - Customer Drw	sheet 3 of 8

PDS: Rev :E

STATUS:Released

Printed: Mar 17, 2016



RIGHT WALL MODULE



SEE DETAIL A  
On Sheet 8 For Details

BP HOLE PATTERN COMPONENT SIDE

RIGHT WALL MODULE BACKPLANE FOOTPRINT



(5.2)  
For 3MM Wipe Signal  
(4.2)  
For 2MM Wipe Signal

Amphenol  
FCi

© 2016 AFci

spec ref	-	dr	Collins Lu	2011/07/27	projection	mm	size	A2	scale	1:1			
tolerance std	ISO 406 ISO 1101	eng	Sandar Soe	2016/03/07		mm	ecn no	ELX-S-17624-1	rel level	Released			
TOLERANCES UNLESS OTHERWISE SPECIFIED		chr	-	appr							Chen-Hong Tan	2016/03/17	product family
surface	ISO 1302	linear	0.X	±0.3			title	MODULE ASSEMBLY, XCEDE HD		dwg no	10115091	rev	E
		angular	0°	±2°	www.fci.com		cat. no.	-		Product - Customer Drw	sheet 4 of 8		

PDS: Rev :E

STATUS:Released

Printed: Mar 17, 2016





△ FOUR WALL MODULE



BP HOLE PATTERN COMPONENT SIDE



△ FOUR WALL MODULE BACKPLANE FOOTPRINT

Amphenol  
FCi

© 2016 AFCI

spec ref	-	dr	Collins Lu	2011/07/27	projection	mm	size	A2	scale	1:1			
tolerance std	ISO 406 ISO 1101	eng	Sandar Soe	2016/03/07		mm	ecn no	ELX-S-17624-1	rel level	Released			
TOLERANCES UNLESS OTHERWISE SPECIFIED		chr	-	appr							Chen-Hong Tan	2016/03/17	product family
surface	linear	0.X	±0.3		<b>MODULE ASSEMBLY, XCEDE HD</b> Vertical Header, 4 Pair 8 Column		dwg no 10115091	rev E	cat. no. - Product - Customer Drw sheet 5 of 8				
		0.XX	±0.10		www.fci.com	PDS: Rev :E			STATUS:Released		Printed: Mar 17, 2016		
	angular	0°	±2°			PDS: Rev :E			STATUS:Released		Printed: Mar 17, 2016		



LEFT POLARIZING/GUIDE MODULE



BP HOLE PATTERN COMPONENT SIDE  
LEFT POLARIZING GUIDE MODULE  
BACKPLANE FOOTPRINT

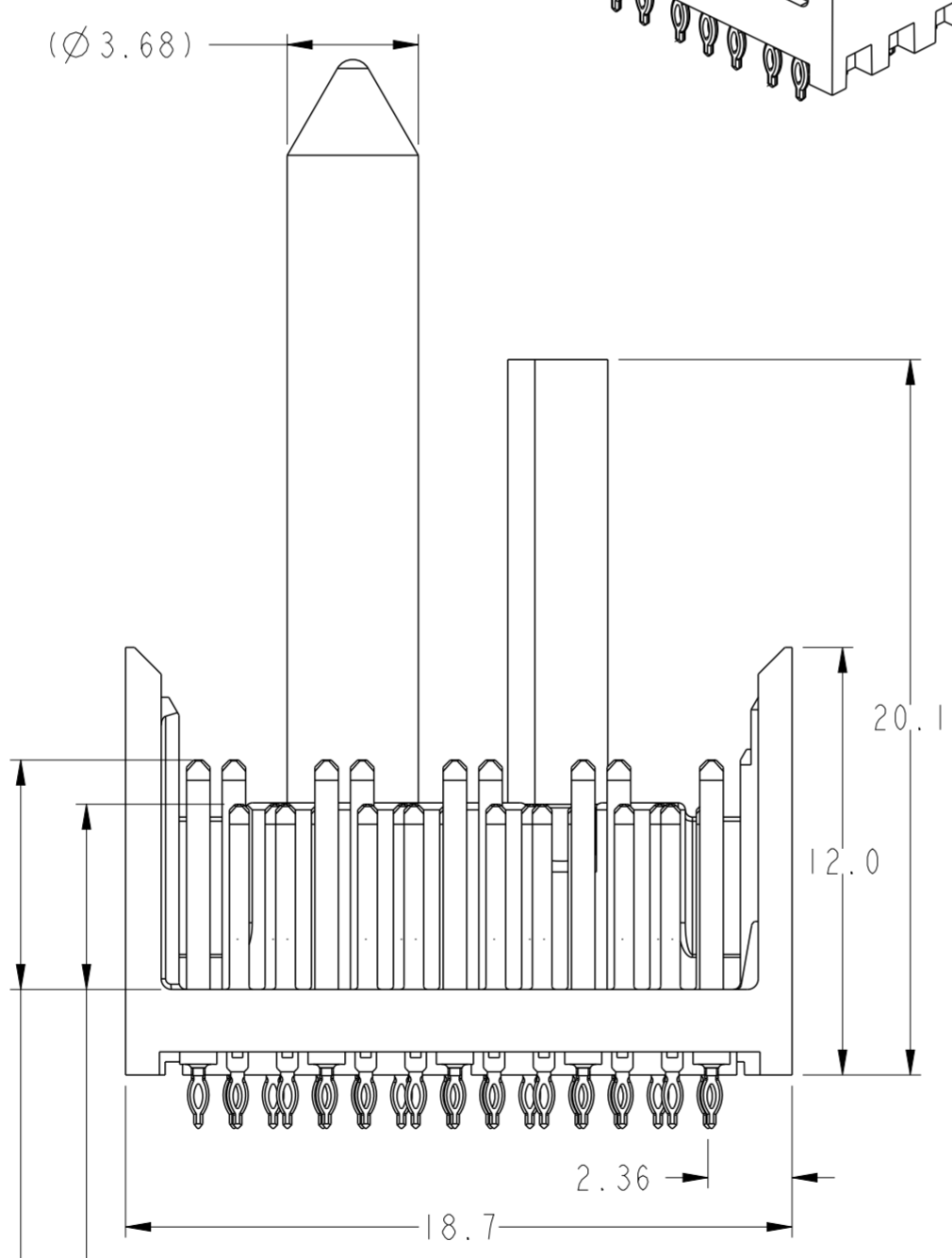
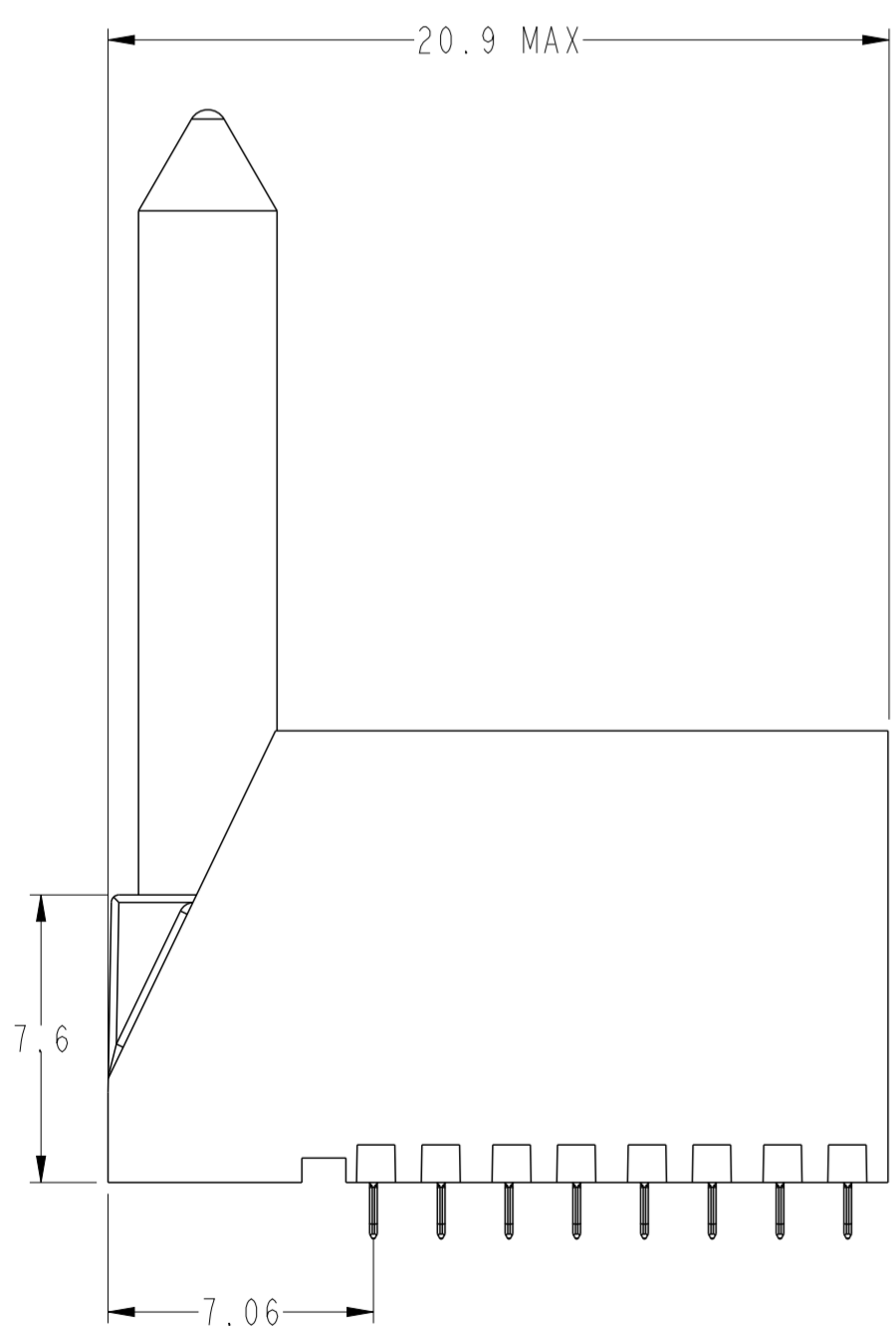

- (5.2) For 3MM Wipe Signal
- (4.2) For 2MM Wipe Signal
- (6.4) For 4MM Wipe Ground
- (5.4) For 3MM Wipe Ground

SEE NOTE 11 & TABLE 1

SEE DETAIL A  
OnSheet 8 For Details

spec ref	-	dr	Collins Lu	2011/07/27	projection	mm	size	A2	scale	1:1	
tolerance std	ISO 406 ISO 1101	eng	Sandar Soe	2016/03/07		mm	ecn no	ELX-S-17624-1	rel level	Released	
TOLERANCES UNLESS OTHERWISE SPECIFIED		chr	-	appr							Chen-Hong Tan
surface	ISO 1302	linear	0.X	±0.3			title	MODULE ASSEMBLY, XCEDE HD		rev	E
		angular	0°	±2°	www.fci.com		cat. no.	Product - Customer Drw		sheet 6 of 8	



Optional Key See Sheet 1  
Part Number Tree

SEE NOTE 5



PIN A1

MODULE OUTLINE  
PIN A1 HOLE



SEE DETAIL A  
On Sheet 8 For Details



BP HOLE PATTERN COMPONENT SIDE  
RIGHT POLAIZING/GUIDE MODULE  
BACKPLANE FOOTPRINT

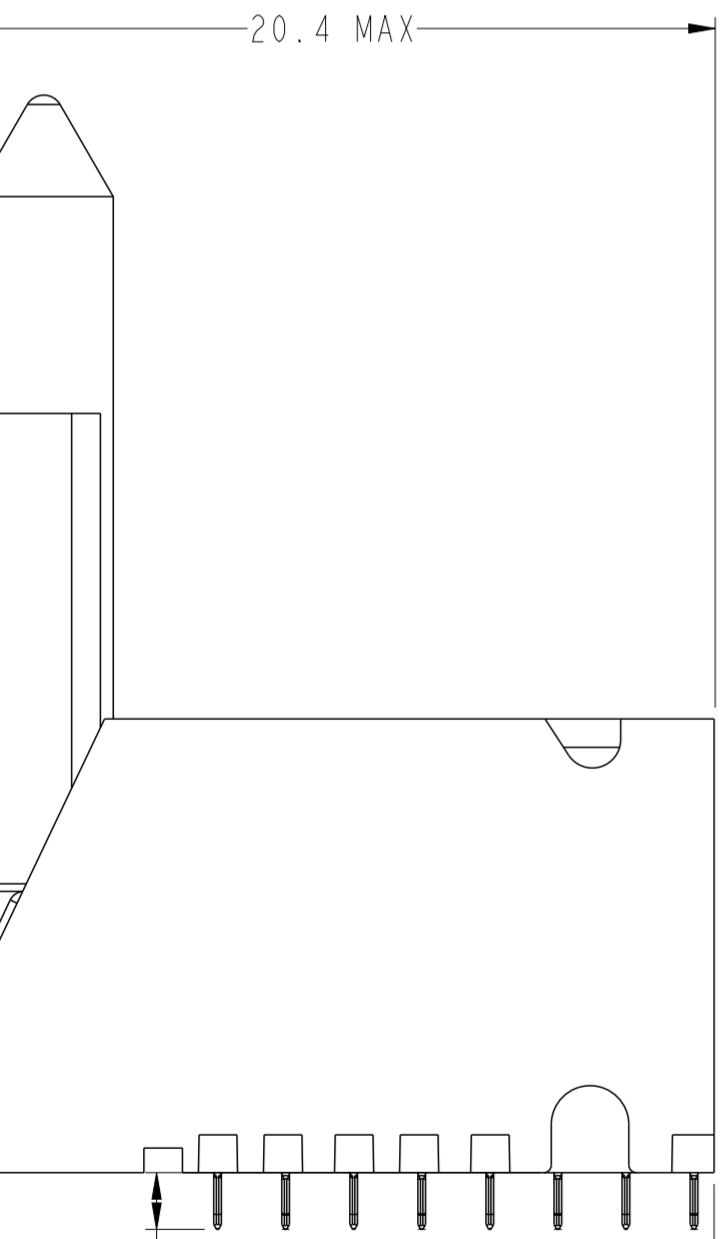

(Ø3.68)

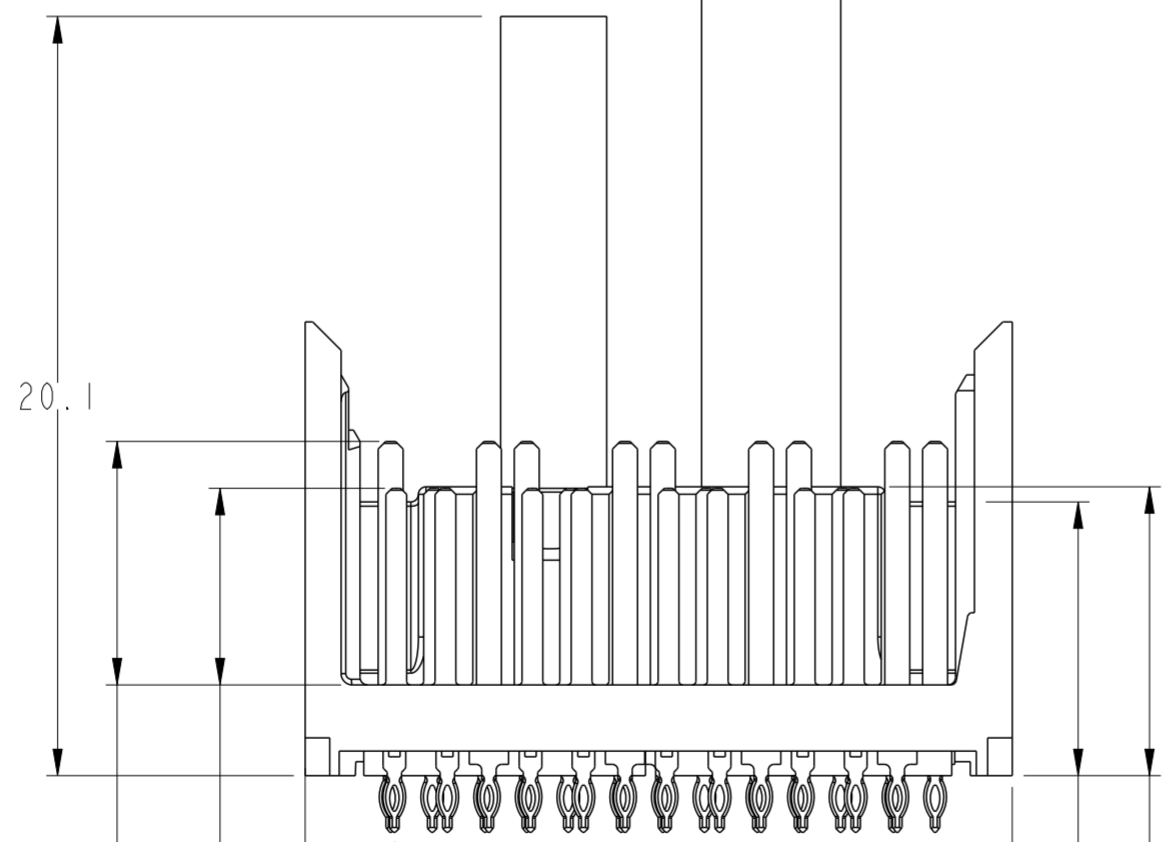

28.5±0.3

(1.5)  
Tail Length

(5.2)  
For 3MM Wipe Signal  
(4.2)  
For 2MM Wipe Signal  
(6.4)  
For 4MM Wipe Ground  
(5.4)  
For 3MM Wipe Ground

spec ref	-	dr	Collins Lu	2011/07/27	projection	mm	size	A2	scale	1:1
tolerance std	ISO 406 ISO 1101	eng	Sandar Soe	2016/03/07			ecn no	ELX-S-17624-1	rel level Released	
surface	ISO 1302	chr	-	appr			Chen-Hong Tan	2016/03/17		product family
linear	0.X ±0.3 0.XX ±0.10 0.XXX ±0.05	<b>Amphenol FCI</b> www.fci.com		TITLE MODULE ASSEMBLY, XCEDE HD Vertical Header, 4 Pair 8 Column		dwg no 10115091	rev E			
angular	0° ±2°	cat. no.		Product - Customer Drw		sheet 7 of 8				

PDS: Rev :E

STATUS:Released

Printed: Mar 17, 2016

Amphenol  
FCi

© 2016 AFCI



A

B

C

D

E

F

TABLE 3		
	COMPLIANT PIN DRILL $\varnothing 0.55 [0.0217"]$	COMPLIANT PIN DRILL $\varnothing 0.45 [0.0177"]$
PTH	$\varnothing 0.45 \pm 0.05$	$\varnothing 0.36 \pm 0.05$
DRILL	$\varnothing 0.55 [0.0217"]$	$\varnothing 0.45 [0.0177"]$
PAD	$\varnothing 0.85$	$\varnothing 0.75$



NOTES:

1. CONNECTOR MATERIALS  
SHROUD : HIGH-TEMP POLYMER, COLOR : BLACK, UL94V-0  
CONTACTS : HIGH PERFORMANCE COPPER ALLOY
2. PRODUCT SPECIFICATION : GS-12-0936
3. APPLICATION SPECIFICATION : GS-20-0348
4. PRODUCT MARKING :  
PART NUMBER (10115091-XOE-XXXLF)  
"FCI" AND DATE CODE (FCI P#####)
5. NOTCH DESIGNATES "ROW A" SIDE OF CONNECTOR. NOTCH FEATURE ON OPPOSITE FOR PRODUCT MARKING.
6. PLATING THICKNESS OF SIGNAL & GROUND CONTACT ARE DETERMINED BY PLATING CODE, REFER TO P/N TREE ON SHEET 1.
7. PACKAGING MEETS GS-14-920 LEAD-FREE LABELING SPECIFICATION.
8. GUIDE-PIN STYLE DESIGNATION ONLY APPLIES TO MODULE VERSIONS THAT REQUIRE GUIDE-PIN HARDWARE. FOR ALL NON-GUIDE-PIN VERSIONS, THE DEFAULT DASH-NUMBER DIGIT IN THAT LOCATION IS STILL '0'.
9. SEE APPLICATION SPECIFICATION FOR ROUTING GUIDELINES, ADDITIONAL PTH GUIDELINES, MATED DIMENSIONS, GUIDE PIN SELECTION, ETC.
10. A  $\triangle E$  SYMBOL WILL BE NEXT TO ANY DIMENSION, VIEW OR NOTE THAT HAS BEEN MODIFIED WITH THE CURRENT DRAWING REVISION.
11. OPTIONAL HOLE LOCATION FOR GROUNDED PIN OR ADDITIONAL GUIDE-PIN SUPPORT. SEE TABLE 1 SHEET 1 FOR ADDITIONAL DETAILS.
12. SCREW IS OPTIONAL AND ENGAGES WITH BOTTOM OF GUIDE PIN FROM BENEATH THE PCB FOR ADDITIONAL GUIDE-PIN SUPPORT.

Amphenol FCI

© 2016 AFCI

spec ref	-	dr	Collins Lu	2011/07/27	projection	mm	size	A2	scale	1:1
tolerance std	ISO 406 ISO 1101	eng	Sandar Soe	2016/03/07			ecn no	ELX-S-17624-1	rel level Released	rev E
surface	ISO 1302	chr	-	appr			Chen-Hong Tan	2016/03/17		
linear	0.X ±0.3 0.XX ±0.10 0.XXX ±0.05	angular	0° ±2°	www.fci.com	cat. no.	-	Product - Customer Drw	10115091	sheet 8 of 8	





Компания «ЭлектроПласт» предлагает заключение долгосрочных отношений при поставках импортных электронных компонентов на взаимовыгодных условиях!

Наши преимущества:

- Оперативные поставки широкого спектра электронных компонентов отечественного и импортного производства напрямую от производителей и с крупнейших мировых складов;
- Поставка более 17-ти миллионов наименований электронных компонентов;
- Поставка сложных, дефицитных, либо снятых с производства позиций;
- Оперативные сроки поставки под заказ (от 5 рабочих дней);
- Экспресс доставка в любую точку России;
- Техническая поддержка проекта, помощь в подборе аналогов, поставка прототипов;
- Система менеджмента качества сертифицирована по Международному стандарту ISO 9001;
- Лицензия ФСБ на осуществление работ с использованием сведений, составляющих государственную тайну;
- Поставка специализированных компонентов (Xilinx, Altera, Analog Devices, Intersil, Interpoint, Microsemi, Aeroflex, Peregrine, Syfer, Eurofarad, Texas Instrument, Miteq, Cobham, E2V, MA-COM, Hittite, Mini-Circuits, General Dynamics и др.);

Помимо этого, одним из направлений компании «ЭлектроПласт» является направление «Источники питания». Мы предлагаем Вам помощь Конструкторского отдела:

- Подбор оптимального решения, техническое обоснование при выборе компонента;
- Подбор аналогов;
- Консультации по применению компонента;
- Поставка образцов и прототипов;
- Техническая поддержка проекта;
- Защита от снятия компонента с производства.



#### Как с нами связаться

**Телефон:** 8 (812) 309 58 32 (многоканальный)

**Факс:** 8 (812) 320-02-42

**Электронная почта:** [org@eplast1.ru](mailto:org@eplast1.ru)

**Адрес:** 198099, г. Санкт-Петербург, ул. Калинина, дом 2, корпус 4, литера А.