

10115091 - X 0 E - X X X L F

8-COLUMN DIFFERENTIAL SIGNAL

LEAD-FREE DESIGNATION ONLY WITH APPLICABLE PLATING CODES

LETTER	PLATING (SEE NOTE 6)	
	APPLICATION	TYPE (REFERENCE)
B	TELCORDIA CO	0.76um GOLD or GXT
C	TELCORDIA UE	1.27um GOLD
D	TELCORDIA CO	0.76um GOLD or GXT, LEAD-FREE
E	TELCORDIA UE	1.27um GOLD, LEAD-FREE

NUMBER	GUIDE PIN STYLE (SEE NOTE 8)
0	STANDARD GUIDE PIN, MACHINED
1	STANDARD GUIDE PIN, ROLLED

MODULE DESCRIPTION	LETTER DESIGNATION REPRESENTED IN DASH NUMBER										BASE MODULE
LEFT POLARIZING GUIDANCE MODULE (SEE SHEET 6)	N	J	A	B	C	D	E	F	G	H	
	NO KEY NO GUIDE PIN										
RIGHT POLARIZING GUIDANCE MODULE (SEE SHEET 7)	Z	Y	P	Q	R	S	T	U	V	W	
	NO KEY NO GUIDE PIN										
OPEN MODULE (TWO WALL) (SEE SHEET 2)	0 (ZERO)										
LEFT WALL MODULE (SEE SHEET 3)	L										
RIGHT WALL MODULE (SEE SHEET 4)	M										
FOUR WALL MODULE (SEE SHEET 5)	1 (ONE)										

NUMBER	CONTACT MATING WIPE LENGTH		COMPLIANT TAIL TYPE (SEE NOTE 9)
	SIGNAL	GROUND	
1	2 MM	4 MM	0.55 (0.0217") DRILL
2	3 MM	4 MM	0.55 (0.0217") DRILL
3	2 MM	4 MM	0.45 MICRO (0.0177") DRILL
4	3 MM	4 MM	0.45 MICRO (0.0177") DRILL
5	2 MM	3 MM	0.55 (0.0217") DRILL
6	3 MM	3 MM	0.55 (0.0217") DRILL
7	2 MM	3 MM	0.45 MICRO (0.0177") DRILL
8	3 MM	3 MM	0.45 MICRO (0.0177") DRILL

FOR CUSTOM-LOADED MODULES, SEE INDIVIDUAL CUSTOM DRAWINGS WITH THE DRAWING-NUMBER FORMAT OF 10115091-XXXX, WHERE: "X" DENOTES MODULE TYPE PER CHART ON THIS SHEET "YYYY" IS A SEQUENTIAL NUMBER BEGINNING WITH "0001".

	UNGROUND	GROUND
FHS	Ø2.35-Ø2.55	Ø2.35-Ø2.55
PAD	N/A	Ø5.50
PLATED	NO	YES
DRILL (mm)	2.44mm	2.58mm
DRILL (in)	0.096"	0.1015"

SCREW P/N	DESCRIPTION	BOARD THICKNESS
10091790-002LF	#2-56 X 0.375" LG. PHILIPS PANHEAD W/SQ CONICAL WASHER	1.60-5.00mm
10091790-003LF	#2-56 X 0.375" LG. PHILIPS PANHEAD W/SQ CONICAL WASHER	5.00-10.00mm

spec ref	tolerance std	TOLERANCES UNLESS OTHERWISE SPECIFIED		
	ISO 406	0.X	±0.3	
	ISO 1101	0.XX	±0.10	
		0.XXX	±0.05	
	ISO 1302	angular	0°	±2°

dr Collins Lu	2011/07/27	projection	mm	size	A2	scale	1:1
eng Sandar Soe	2016/03/07		←→	ecn no	ELX-S-17624-1		
chr -	-			rel level	Released		
appr Chen-Hong Tan	2016/03/17	product family	-	cat. no.	Product - Customer Drw	sheet 1 of 8	rev
Amphenol FCI		MODULE ASSEMBLY, XCEDE HD		10115091		E	
www.fci.com		Vertical Header, 4 Pair 8 Column					

Amphenol FCI

© 2016 AFCI



SEE DETAIL A
On Sheet 8 For Details

BP HOLE PATTERN COMPONENT SIDE
OPEN WALL MODULE BACKPLANE FOOTPRINT



(5.2)
For 3MM Wipe Signal
(4.2)
For 2MM Wipe Signal



spec ref	-	dr	Collins Lu	2011/07/27	projection	mm	size	A2	scale	1:1			
tolerance std	ISO 406 ISO 1101	eng	Sandar Soe	2016/03/07		mm	ecn no	ELX-S-17624-1	rel level	Released			
TOLERANCES UNLESS OTHERWISE SPECIFIED		chr	-	appr							Chen-Hong Tan	2016/03/17	product family
surface	ISO 1302	linear	0.X	±0.3			title	MODULE ASSEMBLY, XCEDE HD		dwg no	10115091	rev	E
		angular	0°	±2°	www.fci.com	cat. no.	-	Product - Customer Drw	sheet 2 of 8				

Amphenol
FCI

© 2016 APCI



LEFT WALL MODULE



SEE DETAIL A
On Sheet 8 For Details



BP HOLE PATTERN COMPONENT SIDE
LEFT WALL MODULE BACKPLANE FOOTPRINT

Amphenol
FCi

© 2016 AFci

spec ref	-	dr	Collins Lu	2011/07/27	projection	mm	size	A2	scale	1:1
tolerance std	ISO 406 ISO 1101	eng	Sandar Soe	2016/03/07		mm	ecn no	ELX-S-17624-1	rel level	Released
TOLERANCES UNLESS OTHERWISE SPECIFIED		chr	-	appr						
surface	ISO 1302	linear	0.X	±0.3			MODULE ASSEMBLY, XCEDE HD Vertical Header, 4 Pair 8 Column		dwg no 10115091	rev E
		angular	0°	±2°	www.fci.com	cat. no.	-	Product - Customer Drw	sheet 3 of 8	

PDS: Rev :E

STATUS:Released

Printed: Mar 17, 2016



RIGHT WALL MODULE



SEE DETAIL A
On Sheet 8 For Details

BP HOLE PATTERN COMPONENT SIDE

RIGHT WALL MODULE BACKPLANE FOOTPRINT



(5.2)
For 3MM Wipe Signal
(4.2)
For 2MM Wipe Signal

Amphenol
FCi

© 2016 AFci

spec ref	-	dr	Collins Lu	2011/07/27	projection	mm	size	A2	scale	1:1
tolerance std	ISO 406 ISO 1101	eng	Sandar Soe	2016/03/07			ecn no	ELX-S-17624-1	rel level Released	rev E
TOLERANCES UNLESS OTHERWISE SPECIFIED		chr	-	appr			Chen-Hong Tan	2016/03/17		
surface	ISO 1302	linear	0.X	±0.3	Amphenol FCI		MODULE ASSEMBLY, XCEDE HD Vertical Header, 4 Pair 8 Column		dwg no 10115091	sheet 4 of 8
		angular	0°	±2°	www.fci.com	cat. no.	Product - Customer Drw			

PDS: Rev :E

STATUS:Released

Printed: Mar 17, 2016



△ FOUR WALL MODULE

BP HOLE PATTERN COMPONENT SIDE

△ FOUR WALL MODULE BACKPLANE FOOTPRINT



(5.2)
For 3MM Wipe Signal
(4.2)
For 2MM Wipe Signal

Amphenol
FCi

© 2016 AFci

spec ref	-	dr	Collins Lu	2011/07/27	projection	mm	size	A2	scale	1:1			
tolerance std	ISO 406 ISO 1101	eng	Sandar Soe	2016/03/07		mm	ecn no	ELX-S-17624-1	rel level	Released			
TOLERANCES UNLESS OTHERWISE SPECIFIED		chr	-	appr							Chen-Hong Tan	2016/03/17	product family
surface	ISO 1302	linear	0.X	±0.3			title	MODULE ASSEMBLY, XCEDE HD		dwg no	10115091	rev	E
		angular	0°	±2°	www.fci.com	cat. no.	-	Product - Customer Drw	sheet 5 of 8				

PDS: Rev :E

STATUS:Released

Printed: Mar 17, 2016



LEFT POLARIZING/GUIDE MODULE



Optional Key See Sheet 1
Part Number Tree

SEE NOTE 5



SEE DETAIL A
OnSheet 8 For Details

BP HOLE PATTERN COMPONENT SIDE
LEFT POLARIZING GUIDE MODULE
BACKPLANE FOOTPRINT

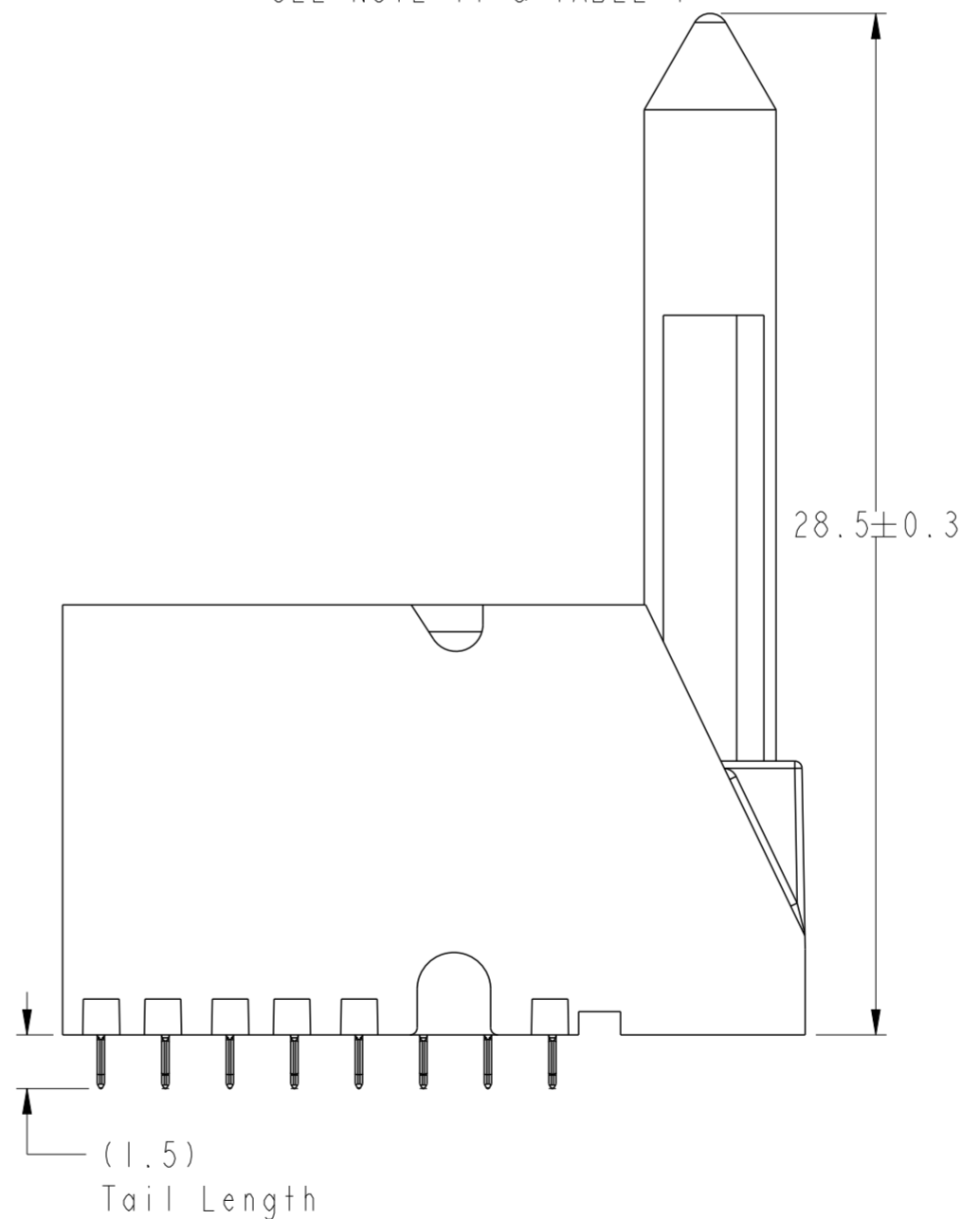
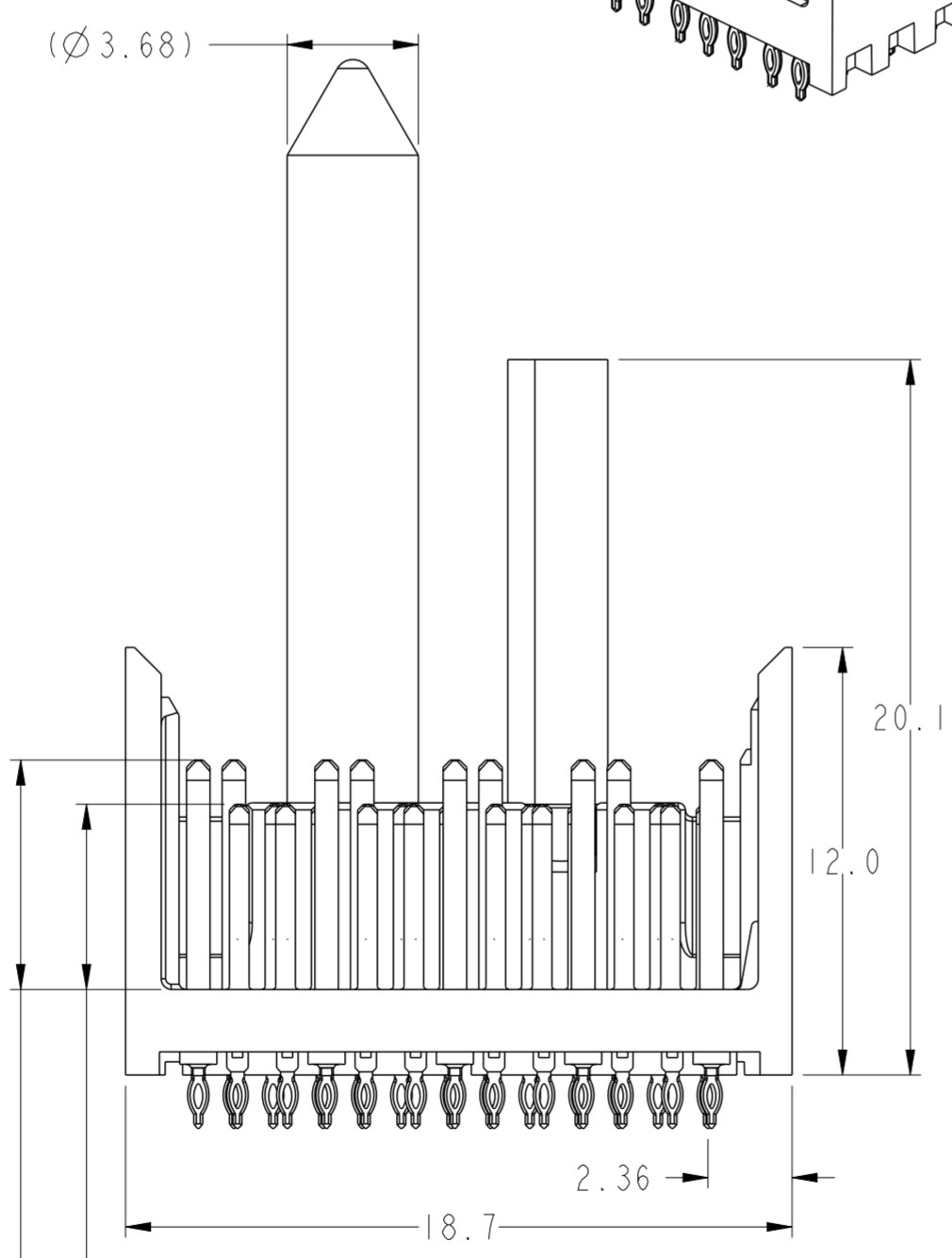
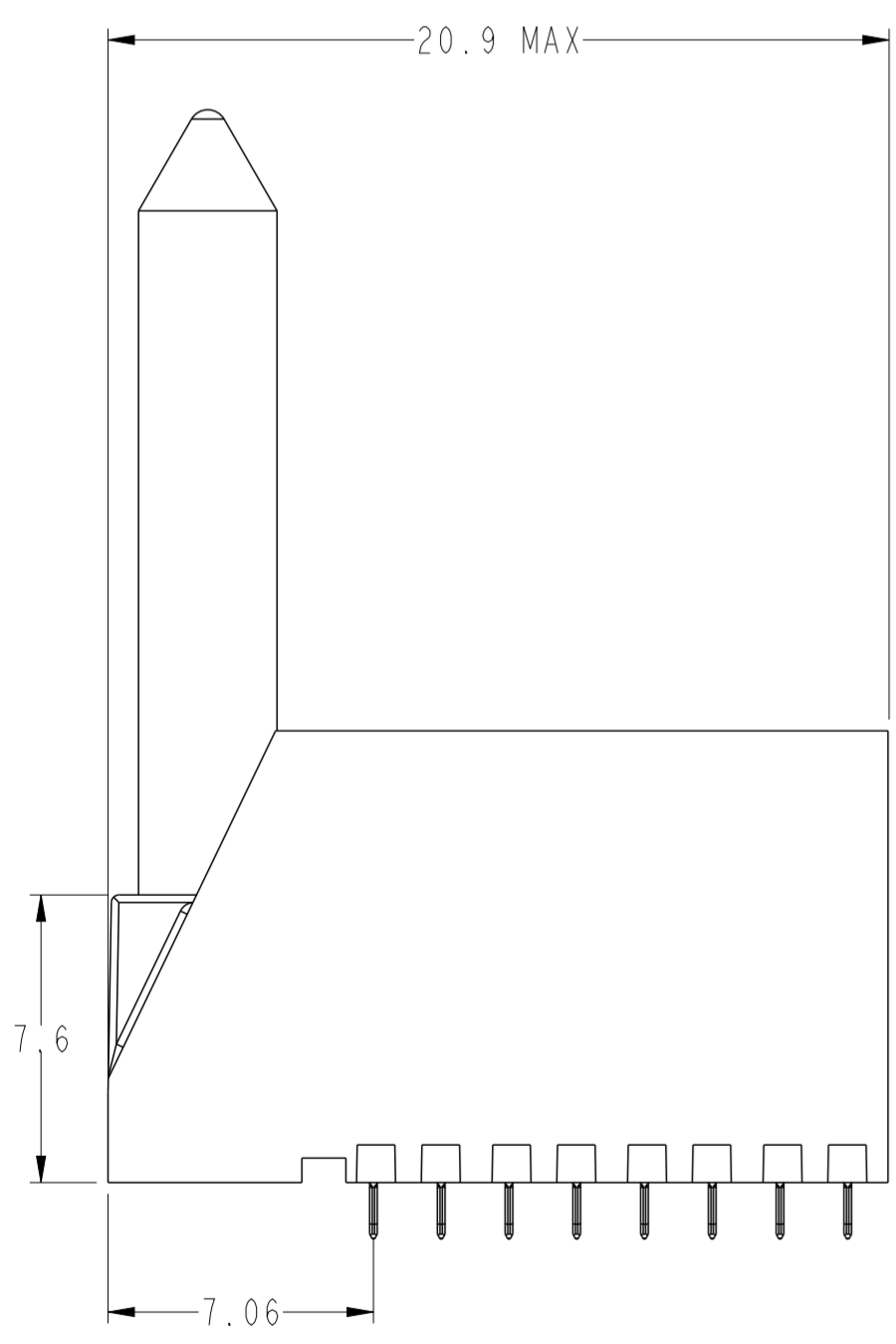

- (5.2) For 3MM Wipe Signal
- (4.2) For 2MM Wipe Signal
- (6.4) For 4MM Wipe Ground
- (5.4) For 3MM Wipe Ground

SEE NOTE 11 & TABLE 1

spec ref	-	dr	Collins Lu	2011/07/27	projection	mm	size	A2	scale	1:1
tolerance std	ISO 406 ISO 1101	eng	Sandar Soe	2016/03/07	chr	-	ecn no	ELX-S-17624-1	rel level	Released
surface	ISO 1302	appr	Chen-Hong Tan	2016/03/17	product family	-	rel level	Released	rev	E
TOLERANCES UNLESS OTHERWISE SPECIFIED		Amphenol FCI		MODULE ASSEMBLY, XCEDE HD		10115091		www.fci.com		sheet 6 of 8
linear	0.X ±0.3 0.XX ±0.10 0.XXX ±0.05	www.fci.com		cat. no.		Product - Customer Drw		STATUS:Released		Printed: Mar 17, 2016
angular	0° ±2°	PDS: Rev :E		STATUS:Released		Printed: Mar 17, 2016				

Amphenol FCI

© 2016 AFCI



Optional Key See Sheet 1
Part Number Tree

SEE NOTE 5



PIN A1

MODULE OUTLINE
PIN A1 HOLE



SEE DETAIL A
On Sheet 8 For Details



BP HOLE PATTERN COMPONENT SIDE
RIGHT POLAIZING/GUIDE MODULE
BACKPLANE FOOTPRINT

RIGHT POLARIZING/GUIDE MOUDLE



(1.5)
Tail Length

(5.2)
For 3MM Wipe Signal
(4.2)
For 2MM Wipe Signal
(6.4)
For 4MM Wipe Ground
(5.4)
For 3MM Wipe Ground

spec ref	-	dr	Collins Lu	2011/07/27	projection	mm	size	A2	scale	1:1	
tolerance std	ISO 406 ISO 1101	eng	Sandar Soe	2016/03/07	chr	-	ecn no	ELX-S-17624-1	rel level	Released	
surface	ISO 1302	appr	Chen-Hong Tan	2016/03/17	product family	-	cat. no.	Product - Customer Drw	sheet 7 of 8	rev	E
linear	0.X ±0.3 0.XX ±0.10 0.XXX ±0.05	angular	0° ±2°	Amphenol FCI MODULE ASSEMBLY, XCEDE HD Vertical Header, 4 Pair 8 Column www.fci.com		title 10115091	dwg no 10115091	rev E			

PDS: Rev :E

STATUS:Released

Printed: Mar 17, 2016

Amphenol
FCi

© 2016 AFCi

A

B

C

D

E

F

TABLE 3		
	COMPLIANT PIN DRILL $\varnothing 0.55 [0.0217"]$	COMPLIANT PIN DRILL $\varnothing 0.45 [0.0177"]$
PTH	$\varnothing 0.45 \pm 0.05$	$\varnothing 0.36 \pm 0.05$
DRILL	$\varnothing 0.55 [0.0217"]$	$\varnothing 0.45 [0.0177"]$
PAD	$\varnothing 0.85$	$\varnothing 0.75$



DETAIL A
SCALE 12:1

NOTES:

1. CONNECTOR MATERIALS
SHROUD : HIGH-TEMP POLYMER, COLOR : BLACK, UL94V-0
CONTACTS : HIGH PERFORMANCE COPPER ALLOY
2. PRODUCT SPECIFICATION : GS-12-0936
3. APPLICATION SPECIFICATION : GS-20-0348
4. PRODUCT MARKING :
PART NUMBER (10115091-XOE-XXXLF)
"FCI" AND DATE CODE (FCI P#####)
5. NOTCH DESIGNATES "ROW A" SIDE OF CONNECTOR. NOTCH FEATURE ON OPPOSITE FOR PRODUCT MARKING.
6. PLATING THICKNESS OF SIGNAL & GROUND CONTACT ARE DETERMINED BY PLATING CODE, REFER TO P/N TREE ON SHEET 1.
7. PACKAGING MEETS GS-14-920 LEAD-FREE LABELING SPECIFICATION.
8. GUIDE-PIN STYLE DESIGNATION ONLY APPLIES TO MODULE VERSIONS THAT REQUIRE GUIDE-PIN HARDWARE. FOR ALL NON-GUIDE-PIN VERSIONS, THE DEFAULT DASH-NUMBER DIGIT IN THAT LOCATION IS STILL "0".
9. SEE APPLICATION SPECIFICATION FOR ROUTING GUIDELINES, ADDITIONAL PTH GUIDELINES, MATED DIMENSIONS, GUIDE PIN SELECTION, ETC.
10. A $\triangle E$ SYMBOL WILL BE NEXT TO ANY DIMENSION, VIEW OR NOTE THAT HAS BEEN MODIFIED WITH THE CURRENT DRAWING REVISION.
11. OPTIONAL HOLE LOCATION FOR GROUNDED PIN OR ADDITIONAL GUIDE-PIN SUPPORT. SEE TABLE 1 SHEET 1 FOR ADDITIONAL DETAILS.
12. SCREW IS OPTIONAL AND ENGAGES WITH BOTTOM OF GUIDE PIN FROM BENEATH THE PCB FOR ADDITIONAL GUIDE-PIN SUPPORT.

Amphenol
FCi

© 2016 AFci

spec ref	-	dr	Collins Lu	2011/07/27	projection	mm	size	A2	scale	1:1		
tolerance std	ISO 406 ISO 1101	eng	Sandar Soe	2016/03/07			ecn no	ELX-S-17624-1	rel level	Released		
TOLERANCES UNLESS OTHERWISE SPECIFIED		chr	-	appr			Chen-Hong Tan	2016/03/17		product family	Module Assembly, XCEDE HD Vertical Header, 4 Pair 8 Column	diag no
surface	ISO 1302	linear	0.X	± 0.3			rev	E	cat. no.	-	Product - Customer Drw	sheet 8 of 8
		angular	0°	$\pm 2^\circ$	www.fci.com							



Компания «ЭлектроПласт» предлагает заключение долгосрочных отношений при поставках импортных электронных компонентов на взаимовыгодных условиях!

Наши преимущества:

- Оперативные поставки широкого спектра электронных компонентов отечественного и импортного производства напрямую от производителей и с крупнейших мировых складов;
- Поставка более 17-ти миллионов наименований электронных компонентов;
- Поставка сложных, дефицитных, либо снятых с производства позиций;
- Оперативные сроки поставки под заказ (от 5 рабочих дней);
- Экспресс доставка в любую точку России;
- Техническая поддержка проекта, помощь в подборе аналогов, поставка прототипов;
- Система менеджмента качества сертифицирована по Международному стандарту ISO 9001;
- Лицензия ФСБ на осуществление работ с использованием сведений, составляющих государственную тайну;
- Поставка специализированных компонентов (Xilinx, Altera, Analog Devices, Intersil, Interpoint, Microsemi, Aeroflex, Peregrine, Syfer, Eurofarad, Texas Instrument, Miteq, Cobham, E2V, MA-COM, Hittite, Mini-Circuits, General Dynamics и др.);

Помимо этого, одним из направлений компании «ЭлектроПласт» является направление «Источники питания». Мы предлагаем Вам помощь Конструкторского отдела:

- Подбор оптимального решения, техническое обоснование при выборе компонента;
- Подбор аналогов;
- Консультации по применению компонента;
- Поставка образцов и прототипов;
- Техническая поддержка проекта;
- Защита от снятия компонента с производства.



Как с нами связаться

Телефон: 8 (812) 309 58 32 (многоканальный)

Факс: 8 (812) 320-02-42

Электронная почта: org@eplast1.ru

Адрес: 198099, г. Санкт-Петербург, ул. Калинина, дом 2, корпус 4, литера А.