



SMT power inductors

Size 12.95 x 9.40 x 5.08

Series/Type: **B82476B1xxxM100**

Date: **June 2013**

© EPCOS AG 2015. Reproduction, publication and dissemination of this publication, enclosures hereto and the information contained therein without EPCOS' prior express consent is prohibited.

EPCOS AG is a TDK Group Company.

Rated inductance 1 ... 1000 μ H

Construction

- Ferrite core
- Winding: enamel copper wire
- Winding soldered to terminals
- Rugged design with plastic terminal carrier

Features

- Temperature range up to +150 °C
- High rated current
- Low DC resistance
- Suitable for lead-free reflow soldering as referenced in JEDEC J-STD 020D
- Qualified to AEC-Q200
- RoHS-compatible

Applications

- Filtering of supply voltages
- Coupling, decoupling
- DC/DC converters
- Automotive electronics
- Industrial electronics
- Consumer electronics

Terminals

- Base material CuSn6P
- Layer structure Ni, Sn (lead-free)
- Electro-plated

Marking

Marking on component:

Manufacturer, L value (in μ H), date code

Minimum data on reel:

Manufacturer, part number, ordering code,

L value and tolerance

quantity, date of packing

Delivery mode and packaging unit

- 24-mm blister tape, reel packing
- Packaging quantity: 750 pcs./reel

Dimensional drawing and layout recommendation

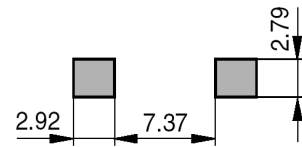
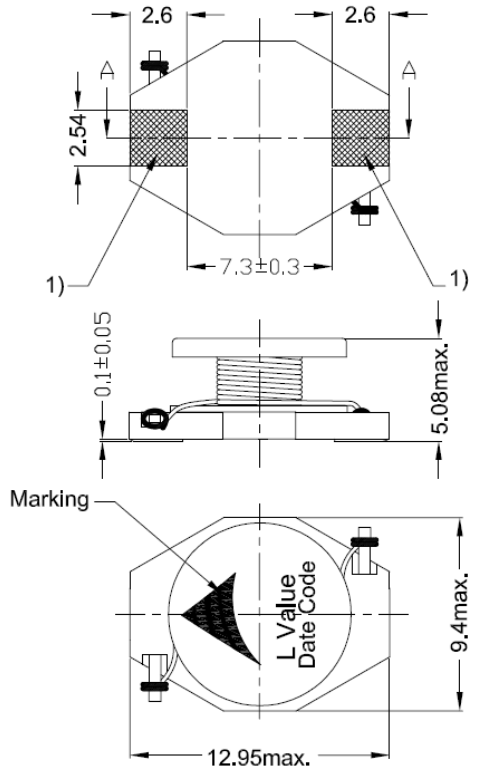

Dimensions in mm
 Component tolerances $\pm 0.2\text{mm}$ unless otherwise noted

1) Soldering area

Taping and packing

Blister tape

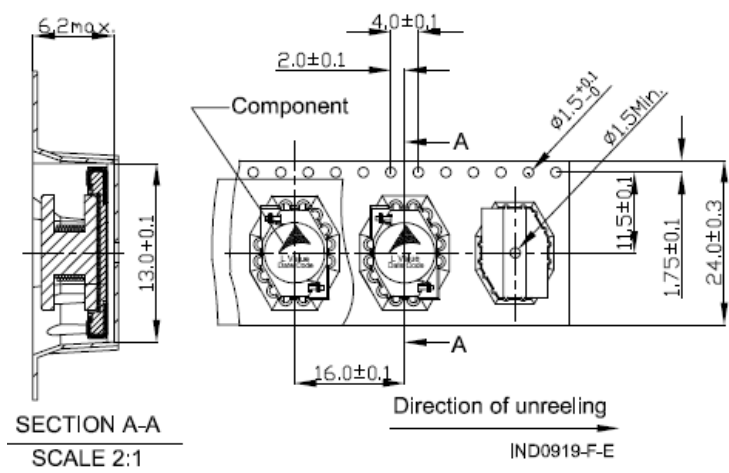

Reel

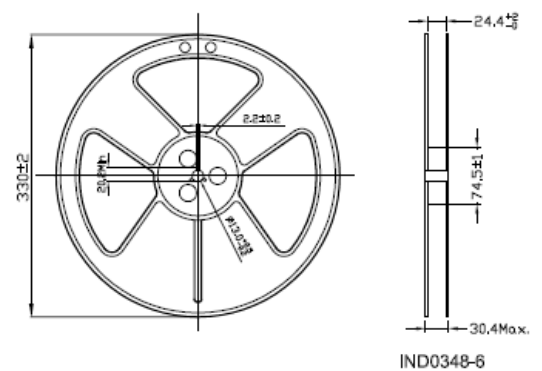

Dimensions in mm

Technical data and measuring conditions

Rated inductance L_R	Measured with LCR meter Agilent 4284A at frequency f_L , 0.1 V
Operating temperature range	-55 °C .. +150 °C
Rated current I_R	Max. permissible DC with temperature increase of ≤ 40 K at +20 °C
Saturation current I_{Sat}	Max. permissible DC with inductance decrease $\Delta L/L_0$ of approx. 10%,
DC resistance R_{typ}	Measured at +20 °C
Solderability (lead-free)	Dip and look method Sn95.5Ag3.8Cu0.7: +(245 \pm 5) °C, (3 \pm 0.3) s Wetting of soldering area $\geq 90\%$ (based on IEC 60068-2-58)
Resistance to soldering heat	+260 °C, 40 s (as referenced in JEDEC J-STD 020D)
Climatic category	55/150/56 (to IEC 60068-1)
Storage conditions	Mounted: -55 °C ... +150 °C Packaged: -25 °C ... +40 °C, $\leq 75\%$ RH
Weight	Approx. 2 g

Characteristics and ordering codes

L_R μH	Tolerance	f_L MHz	I_R A	$I_{sat,min}$ A	$I_{sat,typ}$ A	R_{max} Ω	R_{typ} Ω	Ordering code
1.0	20% = M	0.1	7.50	9.0	12.5	0.0080	0.0060	B82476B1102M100
1.5			6.90	8.0	10.0	0.0090	0.0070	B82476B1152M100
2.2			6.70	7.0	8.00	0.0105	0.0090	B82476B1222M100
3.3			5.90	6.4	6.80	0.0135	0.0115	B82476B1332M100
4.7			5.30	5.4	5.60	0.0165	0.0145	B82476B1472M100
6.8			4.80	4.6	4.90	0.0210	0.0190	B82476B1682M100
10			4.30	3.8	4.25	0.0270	0.0245	B82476B1103M100
15			3.40	3.0	3.40	0.0400	0.0350	B82476B1153M100
22			2.95	2.6	2.80	0.0500	0.0450	B82476B1223M100
33			2.30	2.0	2.15	0.0880	0.0810	B82476B1333M100
47			1.95	1.6	2.05	0.120	0.110	B82476B1473M100
68			1.65	1.4	1.65	0.160	0.150	B82476B1683M100
100			1.40	1.2	1.35	0.230	0.215	B82476B1104M100
150			1.10	1.0	1.15	0.330	0.305	B82476B1154M100
220			0.88	0.8	0.88	0.530	0.480	B82476B1224M100
330			0.65	0.6	0.67	0.810	0.730	B82476B1334M100
470			0.55	0.5	0.56	1.100	1.010	B82476B1474M100
680	0.43	0.4	0.46	1.600	1.500	B82476B1684M100		
1000	0.33	0.3	0.42	2.150	1.950	B82476B1105M100		

Typical curves:

Inductance vs. DC superposition measured with LCR meter Agilent 4284A at $T_a=20\text{ }^\circ\text{C}$



Current derating versus ambient temperature



Cautions and warnings

- Please note the recommendations in our Inductors data book (latest edition) and in the data sheets.
 - Particular attention should be paid to the derating curves given there.
 - The soldering conditions should also be observed. Temperatures quoted in relation to wave soldering refer to the pin, not the housing.
- If the components are to be washed varnished it is necessary to check whether the washing varnish agent that is used has a negative effect on the wire insulation, any plastics that are used, or on glued joints. In particular, it is possible for washing varnish agent residues to have a negative effect in the long-term on wire insulation.
- The following points must be observed if the components are potted in customer applications:
 - Many potting materials shrink as they harden. They therefore exert a pressure on the plastic housing or core. This pressure can have a deleterious effect on electrical properties, and in extreme cases can damage the core or plastic housing mechanically.
 - It is necessary to check whether the potting material used attacks or destroys the wire insulation, plastics or glue.
 - The effect of the potting material can change the high-frequency behaviour of the components.
- Ferrites are sensitive to direct impact. This can cause the core material to flake, or lead to breakage of the core.
- Even for customer-specific products, conclusive validation of the component in the circuit can only be carried out by the customer.

Important notes

The following applies to all products named in this publication:

1. Some parts of this publication contain **statements about the suitability of our products for certain areas of application**. These statements are based on our knowledge of typical requirements that are often placed on our products in the areas of application concerned. We nevertheless expressly point out **that such statements cannot be regarded as binding statements about the suitability of our products for a particular customer application**. As a rule we are either unfamiliar with individual customer applications or less familiar with them than the customers themselves. For these reasons, it is always ultimately incumbent on the customer to check and decide whether a product with the properties described in the product specification is suitable for use in a particular customer application.
2. We also point out that **in individual cases, a malfunction of electronic components or failure before the end of their usual service life cannot be completely ruled out in the current state of the art, even if they are operated as specified**. In customer applications requiring a very high level of operational safety and especially in customer applications in which the malfunction or failure of an electronic component could endanger human life or health (e.g. in accident prevention or life-saving systems), it must therefore be ensured by means of suitable design of the customer application or other action taken by the customer (e.g. installation of protective circuitry or redundancy) that no injury or damage is sustained by third parties in the event of malfunction or failure of an electronic component.
3. **The warnings, cautions and product-specific notes must be observed.**
4. In order to satisfy certain technical requirements, **some of the products described in this publication may contain substances subject to restrictions in certain jurisdictions (e.g. because they are classed as hazardous)**. Useful information on this will be found in our Material Data Sheets on the Internet (www.tdk-electronics.tdk.com/material). Should you have any more detailed questions, please contact our sales offices.
5. We constantly strive to improve our products. Consequently, **the products described in this publication may change from time to time**. The same is true of the corresponding product specifications. Please check therefore to what extent product descriptions and specifications contained in this publication are still applicable before or when you place an order.

We also **reserve the right to discontinue production and delivery of products**. Consequently, we cannot guarantee that all products named in this publication will always be available. The aforementioned does not apply in the case of individual agreements deviating from the foregoing for customer-specific products.
6. Unless otherwise agreed in individual contracts, **all orders are subject to our General Terms and Conditions of Supply**.
7. **Our manufacturing sites serving the automotive business apply the IATF 16949 standard**. The IATF certifications confirm our compliance with requirements regarding the quality management system in the automotive industry. Referring to customer requirements and customer specific requirements ("CSR") TDK always has and will continue to have the policy of respecting individual agreements. Even if IATF 16949 may appear to support the acceptance of unilateral requirements, we hereby like to emphasize that **only requirements mutually agreed upon can and will be implemented in our Quality Management System**. For clarification purposes we like to point out that obligations from IATF 16949 shall only become legally binding if individually agreed upon.
8. The trade names EPCOS, CeraCharge, CeraDiode, CeraLink, CeraPad, CeraPlas, CSMP, CTVS, DeltaCap, DigiSiMic, ExoCore, FilterCap, FormFit, LeaXield, MiniBlue, MiniCell, MKD, MKK, MotorCap, PCC, PhaseCap, PhaseCube, PhaseMod, PhiCap, PowerHap, PQSine, PQvar, SIFERRIT, SIFI, SIKOREL, SilverCap, SIMDAD, SiMic, SIMID, SineFormer, SIOV, ThermoFuse, WindCap are **trademarks registered or pending** in Europe and in other countries. Further information will be found on the Internet at www.tdk-electronics.tdk.com/trademarks.

Release 2018-10

Mouser Electronics

Authorized Distributor

Click to View Pricing, Inventory, Delivery & Lifecycle Information:

EPCOS / TDK:

[B82476B1102M100](#) [B82476B1103M100](#) [B82476B1104M100](#) [B82476B1223M100](#) [B82476B1682M100](#)
[B82476B1224M100](#) [B82476B1472M100](#) [B82476B1332M100](#) [B82476B1152M100](#) [B82476B1683M100](#)
[B82476B1684M100](#) [B82476B1333M100](#) [B82476B1474M100](#) [B82476B1334M100](#) [B82476B1473M100](#)
[B82476B1105M100](#) [B82476B1153M100](#) [B82476B1222M100](#) [B82476B1154M100](#)



Компания «ЭлектроПласт» предлагает заключение долгосрочных отношений при поставках импортных электронных компонентов на взаимовыгодных условиях!

Наши преимущества:

- Оперативные поставки широкого спектра электронных компонентов отечественного и импортного производства напрямую от производителей и с крупнейших мировых складов;
- Поставка более 17-ти миллионов наименований электронных компонентов;
- Поставка сложных, дефицитных, либо снятых с производства позиций;
- Оперативные сроки поставки под заказ (от 5 рабочих дней);
- Экспресс доставка в любую точку России;
- Техническая поддержка проекта, помощь в подборе аналогов, поставка прототипов;
- Система менеджмента качества сертифицирована по Международному стандарту ISO 9001;
- Лицензия ФСБ на осуществление работ с использованием сведений, составляющих государственную тайну;
- Поставка специализированных компонентов (Xilinx, Altera, Analog Devices, Intersil, Interpoint, Microsemi, Aeroflex, Peregrine, Syfer, Eurofarad, Texas Instrument, Miteq, Cobham, E2V, MA-COM, Hittite, Mini-Circuits, General Dynamics и др.);

Помимо этого, одним из направлений компании «ЭлектроПласт» является направление «Источники питания». Мы предлагаем Вам помощь Конструкторского отдела:

- Подбор оптимального решения, техническое обоснование при выборе компонента;
- Подбор аналогов;
- Консультации по применению компонента;
- Поставка образцов и прототипов;
- Техническая поддержка проекта;
- Защита от снятия компонента с производства.



Как с нами связаться

Телефон: 8 (812) 309 58 32 (многоканальный)

Факс: 8 (812) 320-02-42

Электронная почта: org@eplast1.ru

Адрес: 198099, г. Санкт-Петербург, ул. Калинина, дом 2, корпус 4, литера А.