

4

3

2

1

THIS DRAWING IS UNPUBLISHED.		RELEASED FOR PUBLICATION	
© COPYRIGHT - By -		ALL RIGHTS RESERVED.	
PROJECT	PRJ-16-000909157		
PART NO.	X-2308342-X		
DESCRIPTION	FULL METAL HOODS SIZE 3		
CUSTOMER	GENERAL MARKET		

REVISIONS					
P	LTR	DESCRIPTION	DATE	DWN	APVD
	A1	REVISED PER ECR-16-013123	19SEP2016	KK	GG

D

C

B

A

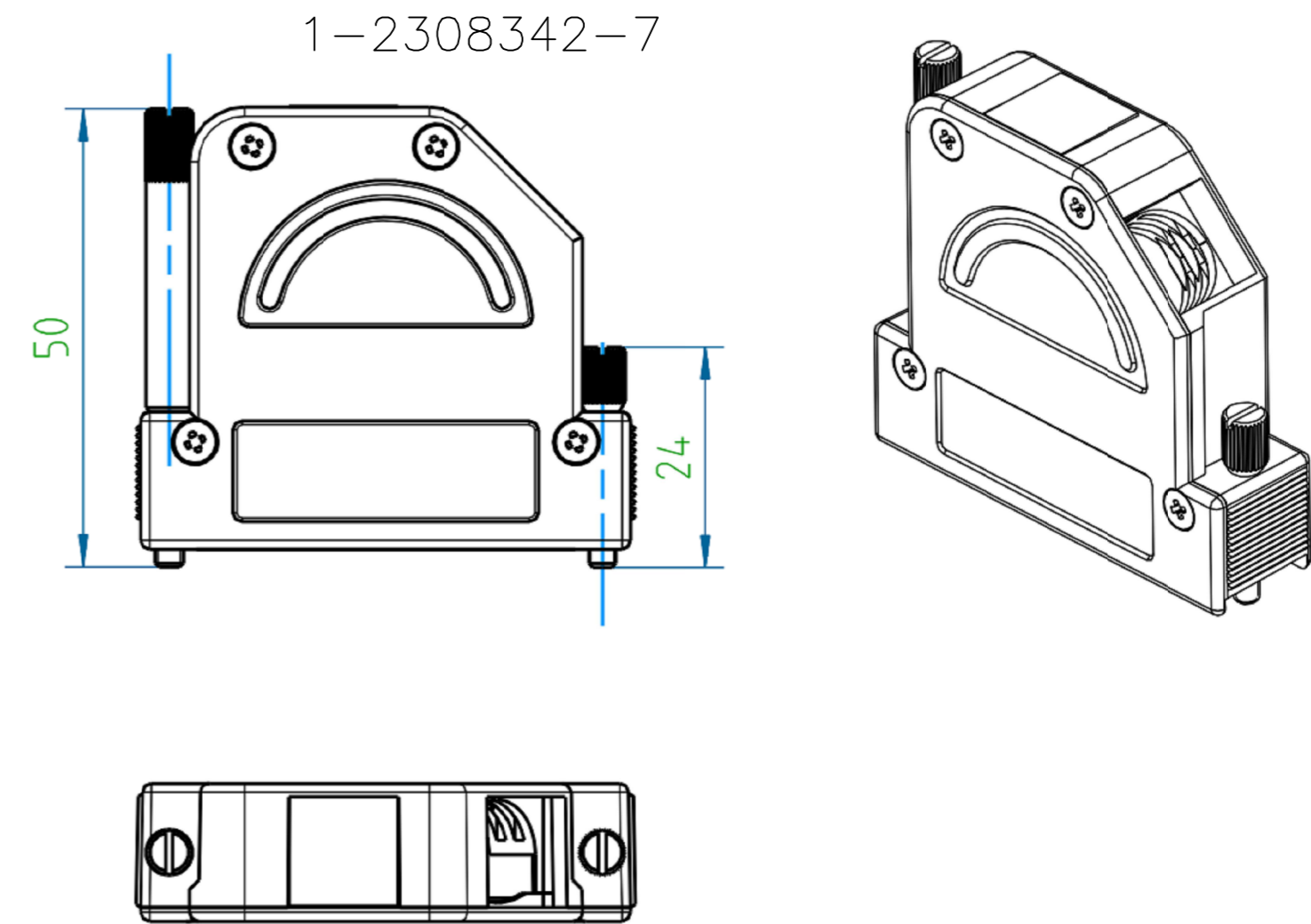
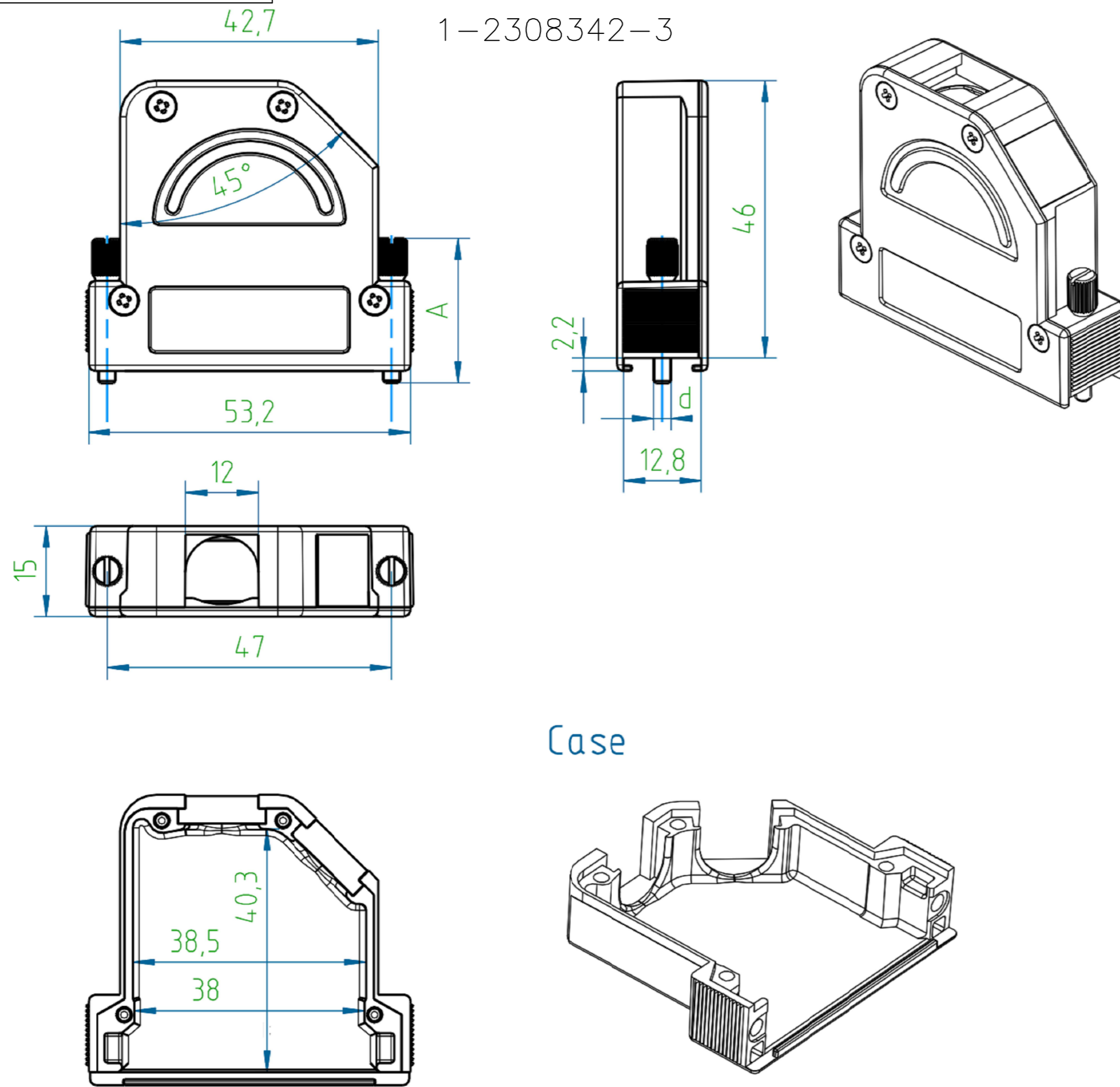

D

C

B

A

NOTES:

- FINISH:  
1-2308342-1 TO 1-2308342-8 - CASE RAW  
1-2308342-9 TO 2-2308342-6 - CASE NICKEL-PLATED
- LOCKING SCREWS: NICKEL-PLATED  
OTHER SCREWS: ZINC-PLATED
- TEMPERATURE RANGE: -40°C TO +90°C
- CABLE DIAMETER WITH EXTERNAL DIAMETER CABLE CLAMP: 4-14 mm.
- STRAND DIAMETER OF CRIMP FLANGE: 2.7-8.7 mm.

THIS DRAWING IS A CONTROLLED DOCUMENT.		DWN KIRAN K 02AUG2016				
DIMENSIONS: mm		CHK GUNASEKHAR G 02AUG2016				
TOLERANCES UNLESS OTHERWISE SPECIFIED: DIN ISO 2768-m DIN 16901 130B		APVD GUNASEKHAR G 02AUG2016	NAME FULL METAL HOODS SIZE 3			
		PRODUCT SPEC	APPLICATION SPEC			
MATERIAL		WEIGHT	SIZE A2	CAGE CODE 00779	DRAWING NO G=2308342	RESTRICTED TO
FINISH		CUSTOMER DRAWING	SCALE NTS	SHEET 1 of 2	REV A1	

THIS DRAWING IS UNPUBLISHED.

RELEASED FOR PUBLICATION

-. - .

© COPYRIGHT - By -

ALL RIGHTS RESERVED.

REVISIONS

P	LTR	DESCRIPTION	DATE	DWN	APVD
-	-	SEE SHEET 1	-	-	-

PART NO.	DESCRIPTION	SUB-PART NO.	DESCRIPTION	A	d	WEIGHT, g
1-2308342-8	FULL METAL HOODS SIZE3-8	1-2308334-6	LOCKING SCREW (M3 LONG KNURLED)	S OVER	M3	72
1-2308342-7	FULL METAL HOODS SIZE3-7	1-2308334-5	LOCKING SCREW (4-40 UNC LONG KNURLED)		4-40 UNC	72
1-2308342-6	FULL METAL HOODS SIZE3-6	1-2308334-6	LOCKING SCREW (M3 LONG KNURLED)	50.0	M3	75
1-2308342-5	FULL METAL HOODS SIZE3-5	1-2308334-5	LOCKING SCREW (4-40 UNC LONG KNURLED)	50.0	4-40 UNC	75
1-2308342-4	FULL METAL HOODS SIZE3-4	1-2308334-4	LOCKING SCREW (M3 SHORT KNURLED)	24.0	M3	67
1-2308342-3	FULL METAL HOODS SIZE3-3	1-2308334-3	LOCKING SCREW (4-40 UNC SHORT KNURLED)	24.0	4-40 UNC	67
1-2308342-2	FULL METAL HOODS SIZE3-2	1-2308334-2	LOCKING SCREW (M3 W/SPRING WASHER)	20.7	M3	66
1-2308342-1	FULL METAL HOODS SIZE3-1	1-2308334-1	LOCKING SCREW (4-40 UNC W/SPRING WASHER)	20.7	4-40 UNC	66
PART NO. (CASE RAW)		LOCKING SCREWS				

PART NO.	DESCRIPTION	SUB-PART NO.	DESCRIPTION	A	d	WEIGHT, g
2-2308342-6	FULL METAL HOODS SIZE3-16	1-2308334-6	LOCKING SCREW (M3 LONG KNURLED)	S OVER	M3	72
2-2308342-5	FULL METAL HOODS SIZE3-15	1-2308334-5	LOCKING SCREW (4-40 UNC LONG KNURLED)		4-40 UNC	72
2-2308342-4	FULL METAL HOODS SIZE3-14	1-2308334-6	LOCKING SCREW (M3 LONG KNURLED)	50.0	M3	75
2-2308342-3	FULL METAL HOODS SIZE3-13	1-2308334-5	LOCKING SCREW (4-40 UNC LONG KNURLED)	50.0	4-40 UNC	75
2-2308342-2	FULL METAL HOODS SIZE3-12	1-2308334-4	LOCKING SCREW (M3 SHORT KNURLED)	24.0	M3	67
2-2308342-1	FULL METAL HOODS SIZE3-11	1-2308334-3	LOCKING SCREW (4-40 UNC SHORT KNURLED)	24.0	4-40 UNC	67
2-2308342-0	FULL METAL HOODS SIZE3-10	1-2308334-2	LOCKING SCREW (M3 W/SPRING WASHER)	20.7	M3	66
1-2308342-9	FULL METAL HOODS SIZE3-9	1-2308334-1	LOCKING SCREW (4-40 UNC W/SPRING WASHER)	20.7	4-40 UNC	66
PART NO. (CASE Ni-PLATED)		LOCKING SCREWS				

NOTE:

- \* CRIMP FLANGE PN \*-2308349-\* TO BE ORDERED SEPARATELY.
- \* CRIMP BARREL TO BE USED IN COMBINATION WITH THE FLANGE PN \*-2308350-\* TO BE ORDERED SEPARATELY.
- \* CABLE CLAMP SCREW VERSION PN \*-2308272-\* TO BE ORDERED SEPARATELY.

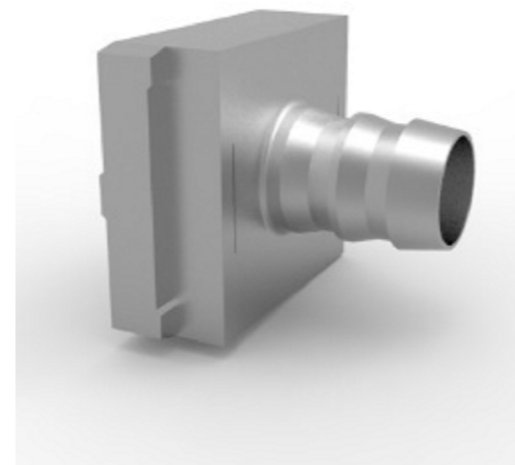

CRIMP FLANGE



CRIMP BARREL

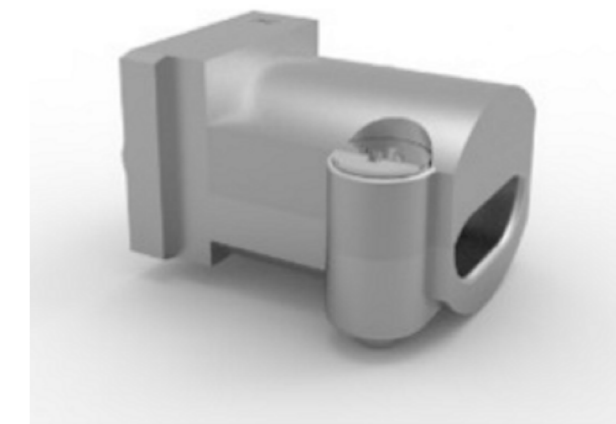

CABLE CLAMP

THIS DRAWING IS A CONTROLLED DOCUMENT.		DWN KIRAN K 02AUG2016		
DIMENSIONS: mm		CHK GUNASEKHAR G 02AUG2016		
TOLERANCES UNLESS OTHERWISE SPECIFIED: DIN ISO 2768-m DIN 16901 130B		APVD GUNASEKHAR G 02AUG2016	NAME FULL METAL HOODS SIZE 3	
0 PLC ± - 1 PLC ± - 2 PLC ± - 3 PLC ± - 4 PLC ± - ANGLES ± -		PRODUCT SPEC APPLICATION SPEC	SIZE A2	CAGE CODE 00779
MATERIAL -		FINISH -	DRAWING NO G=2308342	RESTRICTED TO -
CUSTOMER DRAWING			SCALE NTS	SHEET 2 of 2
			REV A1	



Компания «ЭлектроПласт» предлагает заключение долгосрочных отношений при поставках импортных электронных компонентов на взаимовыгодных условиях!

Наши преимущества:

- Оперативные поставки широкого спектра электронных компонентов отечественного и импортного производства напрямую от производителей и с крупнейших мировых складов;
- Поставка более 17-ти миллионов наименований электронных компонентов;
- Поставка сложных, дефицитных, либо снятых с производства позиций;
- Оперативные сроки поставки под заказ (от 5 рабочих дней);
- Экспресс доставка в любую точку России;
- Техническая поддержка проекта, помощь в подборе аналогов, поставка прототипов;
- Система менеджмента качества сертифицирована по Международному стандарту ISO 9001;
- Лицензия ФСБ на осуществление работ с использованием сведений, составляющих государственную тайну;
- Поставка специализированных компонентов (Xilinx, Altera, Analog Devices, Intersil, Interpoint, Microsemi, Aeroflex, Peregrine, Syfer, Eurofarad, Texas Instrument, Miteq, Cobham, E2V, MA-COM, Hittite, Mini-Circuits, General Dynamics и др.);

Помимо этого, одним из направлений компании «ЭлектроПласт» является направление «Источники питания». Мы предлагаем Вам помощь Конструкторского отдела:

- Подбор оптимального решения, техническое обоснование при выборе компонента;
- Подбор аналогов;
- Консультации по применению компонента;
- Поставка образцов и прототипов;
- Техническая поддержка проекта;
- Защита от снятия компонента с производства.



#### Как с нами связаться

**Телефон:** 8 (812) 309 58 32 (многоканальный)

**Факс:** 8 (812) 320-02-42

**Электронная почта:** [org@eplast1.ru](mailto:org@eplast1.ru)

**Адрес:** 198099, г. Санкт-Петербург, ул. Калинина, дом 2, корпус 4, литера А.