

LTC2209

16-Bit, 160Msps/180Msps/ 185Msps ADCs

DESCRIPTION

Demonstration circuit 1281A supports a family of 16-bit 160Msps/180Msps/185Msps ADCs. Each assembly features one of the following devices: LTC[®]2209, LTC2209#3BC, or LTC2209#3CD high speed, high dynamic range ADC.

Other members of this family include the LTC2208 which is a 130Msps 16-bit version of this device. The LTC2208 is supported on the DC854 (CMOS) and the DC996 (LVDS). Lower speed, single-ended clock versions are also supported on the DC918 and DC919.

Several versions of the 1281A demo board supporting the LTC2209 16-bit series of A/D converters are listed in Table 1. Depending on the required resolution, sample rate and input frequency, the DC1281A is supplied with the appropriate ADC and with an optimized input circuit. The circuitry on the analog inputs is optimized for analog input frequencies below 80MHz or from 80MHz to 160MHz. For higher input frequencies, contact the factory for support.

Design files for this circuit board are available at <http://www.linear.com/demo>

LT, LT, LTC, LTM, Linear Technology and the Linear logo are registered trademarks; QuikEval and PScope are trademarks of Linear Technology Corporation. All other trademarks are the property of their respective owners.

Table 1. DC1281A Variants

DC1281A VARIANTS	ADC PART NUMBER	RESOLUTION	MAXIMUM SAMPLE RATE	INPUT FREQUENCY	SUPPLY VOLTAGE
1281A-A	LTC2209	16-Bit	160Msps	1MHz to 80MHz	3.3V
1281A-B	LTC2209	16-Bit	160Msps	80MHz to 160MHz	3.3V
1281A-E	LTC2209#3BCPBF	16-Bit	180Msps	1MHz to 80MHz	3.6V
1281A-F	LTC2209#3BCPBF	16-Bit	180Msps	80MHz to 160MHz	3.6V
1281A-G	LTC2209#3CDPBF	16-Bit	185Msps	1MHz to 80MHz	3.6V
1281A-H	LTC2209#3CDPBF	16-Bit	185Msps	80MHz to 160MHz	3.6V

PERFORMANCE SUMMARY (T_A = 25°C)

PARAMETER	CONDITION	VALUE
Supply Voltage – LTC2209	Depending on Sampling Rate and the A/D Converter Provided, This Supply Must Provide Up to 700mA.	Optimized for 3.3V [3.15V↔3.45V min/max]
Supply Voltage – LTC2209#3BC and LTC2209#3CD	Depending on Sampling Rate and the A/D Converter Provided, This Supply Must Provide Up to 700mA.	Optimized for 3.6V [3.5V↔3.78V min/max]
Analog Input Range	Depending on PGA Pin Voltage	1.5V _{P-P} to 2.25V _{P-P}
Logic Input Voltages	Minimum Logic High Maximum Logic Low	2V 0.8V
Logic Output Voltages (Differential)	Nominal Logic Levels (100Ω Load) Minimum Logic Levels (100Ω Load)	350mV/2.1V Common Mode 247mV/2.1V Common Mode
Sampling Frequency (Convert Clock Frequency)	See Table 1	
Convert Clock Level	50Ω Source Impedance, AC-Coupled or Ground Referenced (Convert Clock Input Is Capacitor Coupled on Board and Terminated with 50Ω).	2V _{P-P} ↔2.5V _{P-P} Sine Wave or Square wave
Resolution	See Table 1	
Input Frequency Range	See Table 1	
SFDR	See Applicable Data Sheet	
SNR	See Applicable Data Sheet	

QUICK START PROCEDURE

Demonstration circuit 1281A is easy to set up to evaluate the performance of the LTC2209 A/D converters. Refer to Figure 1 for proper measurement equipment setup and follow the procedure below:

Setup

If a DC890 QuikEval™ II Data Acquisition and Collection System was supplied with the DC1281A demonstration circuit, follow the DC890 Quick Start Guide to install the required software and for connecting the DC890 to the DC1281A and to a PC.

DC1281A Demonstration Circuit Board Jumpers

The DC1281A demonstration circuit board should have the following jumper settings as default: (as per Figure 1):

J2: Mode (VCC) 2's Complement DCS Off

J3: SHDN: (Run) Dither (Off)

J4: RAND (Off) PGA 1x

J9: Unused Power Connector

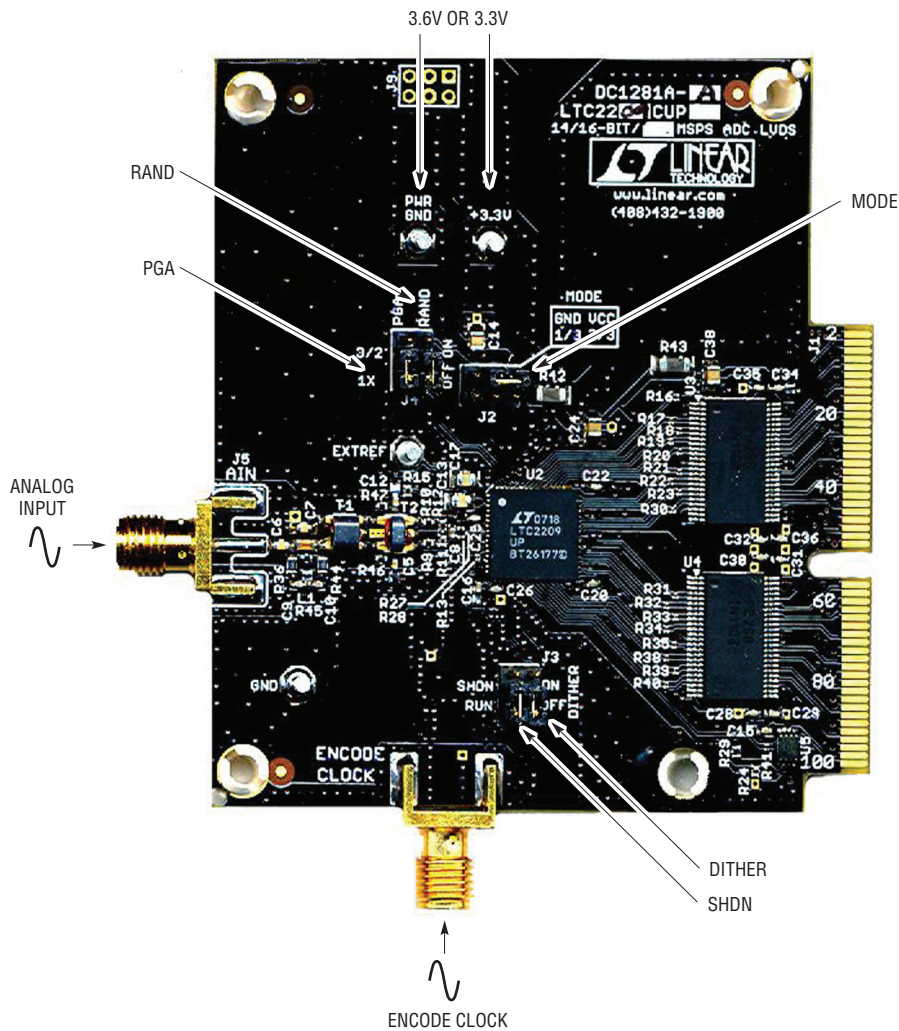

Figure 1. DC1281A Setup (Zoom for Detail)

QUICK START PROCEDURE

Applying Power and Signals to the DC896 Demonstration Circuit

If a DC890 is used to acquire data from the DC1281A, the DC890 must *first* be connected to a powered USB port or provided an external 6V to 9V *before* applying 3.3V or 3.6V across the pins marked +3.3V and PWR GND on the DC1281A. The LTC2209#3BC and LTC2209#3CD require 3.6V for proper operation. The DC1281A demonstration circuit requires up to 700mA depending on the sampling rate and the A/D converter supplied.

The DC890 data collection board is powered by the USB cable and does not require an external power supply unless it must be connected to the PC through an unpowered hub in which case it must be supplied an external 6V to 9V on turrets G7(+) and G1(–) or the adjacent 2.1mm power jack.

Analog Input Network

For optimal distortion and noise performance the RC network on the analog inputs may need to be optimized for different analog input frequencies. For input frequencies above 160MHz use demonstration circuit 1281A. Other input networks may be more appropriate for input frequencies less than 5MHz.

In almost all cases, filters will be required on both analog input and encode clock to provide data sheet SNR.

The filters should be located close to the inputs to avoid reflections from impedance discontinuities at the driven end of a long transmission line. Most filters do not present 50Ω outside the passband. In some cases, 3dB to 10dB pads may be required to obtain low distortion.

If your generator cannot deliver full-scale signals without distortion, you may benefit from a medium power amplifier based on a Gallium Arsenide Gain block prior to the final filter. This is particularly true at higher frequencies where IC-based operational amplifiers may be unable to deliver the combination of low noise figure and High IP3 point required. A high order filter can be used prior to this final amplifier, and a relatively lower Q filter used between the amplifier and the demo circuit.

Encode Clock

Note: This is not a logic-compatible input. It is terminated with 50Ω. Apply an encode clock to the SMA connector on the DC1281A demonstration circuit board marked J7 ENCODE INPUT. This is a transformer-coupled input, terminated on the secondary side in two steps, 100Ω at the transformer with final termination at the ADC at 100Ω.

For the best noise performance, the ENCODE INPUT must be driven with a very low jitter source. When using a sinusoidal generator, the amplitude should often be as large as possible, up to 3V_{P-P} or 15dBm. Using bandpass filters on the clock and the analog input will improve the noise performance by reducing the wideband noise power of the signals. Data sheet FFT plots are taken with 10-pole LC filters made by TTE (Los Angeles, CA) to suppress signal generator harmonics, non-harmonically related spurs and broadband noise. Low phase noise Agilent 8644B generators are used with TTE bandpass filters for both the clock input and the analog input.

Apply the analog input signal of interest to the SMA connectors on the DC1281A demonstration circuit board marked J5 ANALOG INPUT. These inputs are capacitive coupled to Balun transformers ETC1-1-13, or directly coupled through Flux-coupled transformers ETC1-1T.

An internally generated conversion clock output is available on J1 which could be collected via a logic analyzer, or other data collection system if populated with a SAMTEC MEC8-150 type connector or collected by the DC890 QuikEval II Data Acquisition Board using PScope™ software.

Software

The DC890 is controlled by the PScope system software provided or downloaded from the Linear Technology website at <http://www.linear.com/software/>. If a DC890 was provided, follow the DC890 Quick Start Guide and the instructions below.

To start the data collection software if PScope.exe is installed (by default) in \Program Files\LTC\PScope\, double click the PScope icon or bring up the run window under the start menu and browse to the PScope directory and select PScope.

QUICK START PROCEDURE

If the DC1281A demonstration circuit is properly connected to the DC890, PScope should automatically detect the DC1281A, and configure itself accordingly. If necessary the procedure below explains how to manually configure PScope.

Under the Configure menu, go to ADC Configuration.... Check the Config Manually box and use the following configuration options, see Figure 2:

Manual configuration settings:

- Bits: 16
- Alignment: 16
- FPGA Ld: LVDS
- Channs: 1
- Bipolar: Checked
- Positive-Edge Clk: Checked

If everything is hooked up properly, powered and a suitable convert clock is present, clicking the Collect button should result in time and frequency plots displayed in the PScope window. Additional information and help for PScope is available in the DC890 Quick Start Guide and in the online help available within the PScope program itself.

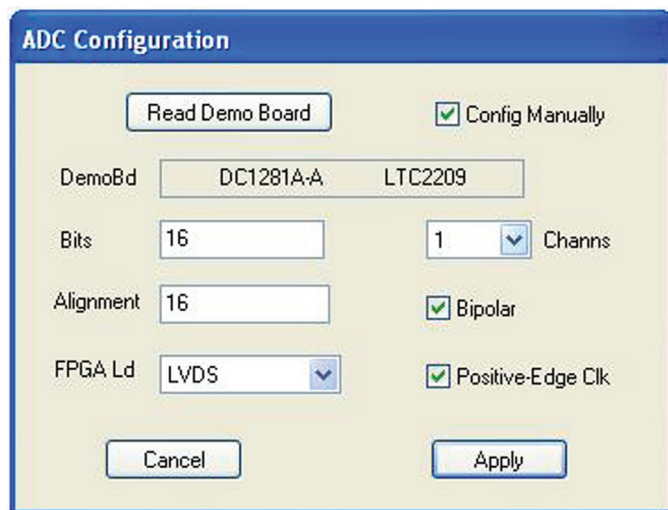

Figure 2: ADC Configuration

PARTS LIST

ITEM	QTY	REFERENCE	PART DESCRIPTION	MANUFACTURER/PART NUMBER
1	5	C1-C3, C6-C7	CAP~X7R~0.01μF~16V~10%~0603	AVX/0603YC103KAT
2	2	C13, C17	CAP~X5R~2.2μF~10V~20%~0805	AVX/0805ZD225MAT
3	3	C14, C24, C38	CAP~X5R~4.7μF~10V~20%~0805	AVX/0805ZD475MAT
4	15	C15-C16, C20, C22, C25-C32, C34-C36	CAP~X5R~0.1μF~10V~10%~0402	AVX/0402ZD104KAT
5	0	C18-C19 (Option)	CAP~X7R~0.1μF~16V~10%~0603	AVX/0603YC104KAT
6	1	C4 (ALSO C9-C10 OPTIONS)	CAP~NPO~8.2pF~50V~0.25pF~0402	AVX/04025A8R2CAT2A
7	2	C5, C12	CAP~X5R~0.01μF~16V~10%~0402	AVX/0402YC103KAT
8	3	J2-J4	HEADER~3 × 2~2mm	SAMTEC, TMM-103-02-L-D
9	0	J9 (OPTION)	HEADER~3 × 2~2mm	SAMTEC, TMM-103-02-L-D
10	2	J5, J7	CONN~SMA 50Ω EDGE-LAUNCH	AMPHENOL_CONNEX/132357
11	2	R42-R43	FERRITE BEAD~SMT~1206	MURATA/BLM31PG330SN1L
12	2	R9-R10	RES~10Ω~1%~1/16~0402	VISHAY, CRCW040210R0FKED
13	1	R15	RES~100Ω~1%~1/16~0402	VISHAY, CRCW0402100R0FKED

PARTS LIST

ITEM	QTY	REFERENCE	PART DESCRIPTION	MANUFACTURER/PART NUMBER
14	1	R37	RES~100Ω~1%~1/16W~0603	VISHAY, CRCW0603100RFKEA
15	19	R13, R16-R23, R30-R35, R38-R41	RES~100Ω~5%~1/20~0201	ACC/CR20-101JM
16	4	R6-8, R14	RES~1k~1%~1/16W~0603	VISHAY, CRCW06031K00FKEA
17	1	R24	RES~100k~1%~1/16~0402	VISHAY, CRCW0402100FKED
18	2	R1, R2	RES~49.9Ω~1%~1/16~0402	VISHAY, CRCW040249R9FKED
19	0	R3 (OPTION)	RES~100Ω~1%~1/16W~0603	AAC/CR16-1000FM
20	4	R11-R12, R46-R47	RES~68.1Ω~1%~1/16~0402	VISHAY, CRCW040268R1FKED
21	3	R25, R26, R29	RES~4990Ω~1%~1/16~0402	VISHAY, CRCW04024K99FKED
22	2	R27-R28	RES~10Ω~5%~1/20~0201	VISHAY, CRCW020110R0JNTD
23	2	R4-R5	RES~5.11Ω~1%~1/16~0402	AAC/CR05-5R11FM
24	1	T3 Put Bal.905 in 1058 987 854D	XFRM~RF~SMT~1:1BALUN	M/A-COM, MABA-007159-000000 (PbF)
25	4	TP1-2, TP4-5	TURRET	MILL_MAX/2308-2
26	1	U1	IC~SERIAL_EEPROM~TSSOP8	MICROCHIP/24LC025-I /ST
27	2	U3, U4	BUFFER~LVDS~OCTAL	FAIRCHILD/FIN1108MTD
28	1	U5	BUFFER~LVDS~SINGLE	FAIRCHILD/FIN1101K8X
29	4	Z (STAND-OFF)	STAND-OFF, NYLON 0.25" tall	KEYSTONE, 8831(SNAP ON)
30	5		SHUNT, 0.079" CENTER	SAMTEC, 2SN-BK-G
31	2		STENCIL, 20 × 20	STENCIL 1281A, 20 × 20
32	1		FAB., PCB	DEMO CIRCUIT 1281A

DC1281A-A

1	1	DC1281A	GENERAL BOM	
2	1	C8	CAP~NPO~4.7pF~50V~0.25pF~0402	AVX/04025A4R7CAT2A
3	2	C9-C10	CAP~NPO~8.2pF~50V~0.25pF~0402	AVX/04025A8R2CAT2A
4	1	L1	IND~56nH~5%~0603	MURATA/LQP18MN56NG02D
5	2	R36, R44	RES~86.6~1%~1/16W~0603	VISHAY, CRCW060386R6FKEA
6	1	R45	RES~86.6~1%~1/16~0402	VISHAY, CRCW040286R6FKED
7	1	T1	BALUN~RF~SMT~1:1	M/A-COM, MABA-007159-000000 (PbF)
8	1	T2	XFRM~RF~SMT~1:1CT	M/A-COM, MABAES0060 (PbF)
9	1	U2	ADC~16BIT~160MSPS	LINEAR/LTC2209CUP#PBF

DC1281A-B

1	1	DC1281A	GENERAL BOM	
2	1	C8	CAP~NPO~1.8pF~50V~0.25pF~0402	AVX/04025A1R8CAT2A
3	2	C9-10	CAP~NPO~3.9pF~50V~0.25pF~0402	AVX/04025A3R9CAT2A
4	1	L1	IND~18nH~5%~0603	MURATA/LQP18MN18NG02D
5	2	R36, R44	RES~43.2Ω~1%~1/16W~0603	VISHAY, CRCW060343R2FKEA
6	1	R45	RES~182Ω_JUMPER~0402	VISHAY, CRCW0402182RFKED
7	1	T1	BALUN~RF~SMT~1:1	M/A-COM, MABA-007159-000000 (PbF)
8	1	T2	TRANSFORMER, WBC1-1L	Coilcraft, WBC1-1L
9	1	U2	ADC~16-BIT~160MSPS	LINEAR/LTC2209CUP#PBF

DEMO MANUAL DC1281A

PARTS LIST

ITEM	QTY	REFERENCE	PART DESCRIPTION	MANUFACTURER/PART NUMBER
DC1281A-E				
1	1	DC1281A	GENERAL BOM	
2	1	C8	CAP~NPO~4.7pF~50V~0.25pF~0402	AVX/04025A4R7CAT2A
3	2	C9-C10	CAP~NPO~8.2pF~50V~0.25pF~0402	AVX/04025A8R2CAT2A
4	1	L1	IND~56nH~5%~0603	MURATA/LQP18MN56NG02D
5	2	R36, R44	RES~86.6Ω~1%~1/16W~0603	VISHAY, CRCW060386R6FKEA
6	1	R45	RES~86.6Ω~1%~1/16~0402	VISHAY, CRCW040286R6FKED
7	1	T1	BALUN~RF~SMT~1:1	M/A-COM, MABA-007159-000000 (PbF)
8	1	T2	XFRM~RF~SMT~1:1CT	M/A-COM, MABAES0060 (PbF)
9	1	U2	ADC~16-BIT~180MSPS	LINEAR/LTC2209CUP#3BCPBF
DC1281A-F				
1	1	DC1281A	GENERAL BOM	
2	1	C8	CAP~NPO~1.8pF~50V~0.25pF~0402	AVX/04025A1R8CAT2A
3	2	C9-10	CAP~NPO~3.9pF~50V~0.25pF~0402	AVX/04025A3R9CAT2A
4	1	L1	IND~18nH~5%~0603	MURATA/LQP18MN18NG02D
5	2	R36,R44	RES~43.2Ω~1%~1/16W~0603	VISHAY, CRCW060343R2FKEA
6	1	R45	RES~182Ω_JUMPER~0402	VISHAY, CRCW0402182RFKED
7	1	T1	BALUN~RF~SMT~1:1	M/A-COM, MABA-007159-000000 (PbF)
8	1	T2	TRANSFORMER, WBC1-1L	Coilcraft, WBC1-1L
9	1	U2	ADC~16-BIT~180MSPS	LINEAR/LTC2209CUP#3BCPBF
DC1281A-G				
1	1	DC1281A	GENERAL BOM	
2	1	C8	CAP~NPO~4.7pF~50V~0.25pF~0402	AVX/04025A4R7CAT2A
3	2	C9-10	CAP~NPO~8.2pF~50V~0.25pF~0402	AVX/04025A8R2CAT2A
4	1	L1	IND~56nH~5%~0603	MURATA/LQP18MN56NG02D
5	2	R36, R44	RES~86.6Ω~1%~1/16W~0603	VISHAY, CRCW060386R6FKEA
6	1	R45	RES~86.6Ω~1%~1/16~0402	VISHAY, CRCW040286R6FKED
7	1	T1	BALUN~RF~SMT~1:1	M/A-COM, MABA-007159-000000 (PbF)
8	1	T2	XFRM~RF~SMT~1:1CT	M/A-COM, MABAES0060 (PbF)
9	1	U2	ADC~16-BIT~185MSPS	LINEAR/LTC2209CUP#3CDPBF
DC1281A-H				
1	1	DC1281A	GENERAL BOM	
2	1	C8	CAP~NPO~1.8pF~50V~0.25pF~0402	AVX/04025A1R8CAT2A
3	2	C9-C10	CAP~NPO~3.9pF~50V~0.25pF~0402	AVX/04025A3R9CAT2A
4	1	L1	IND~18nH~5%~0603	MURATA/LQP18MN18NG02D
5	2	R36, R44	RES~43.2Ω~1%~1/16W~0603	VISHAY, CRCW060343R2FKEA
6	1	R45	RES~182Ω_JUMPER~0402	VISHAY, CRCW0402182RFKED
7	1	T1	BALUN~RF~SMT~1:1	M/A-COM, MABA-007159-000000 (PbF)
8	1	T2	TRANSFORMER, WBC1-1L	Coilcraft, WBC1-1L
9	1	U2	ADC~16-BIT~185MSPS	LINEAR/LTC2209CUP#3CDPBF

SCHEMATIC DIAGRAM

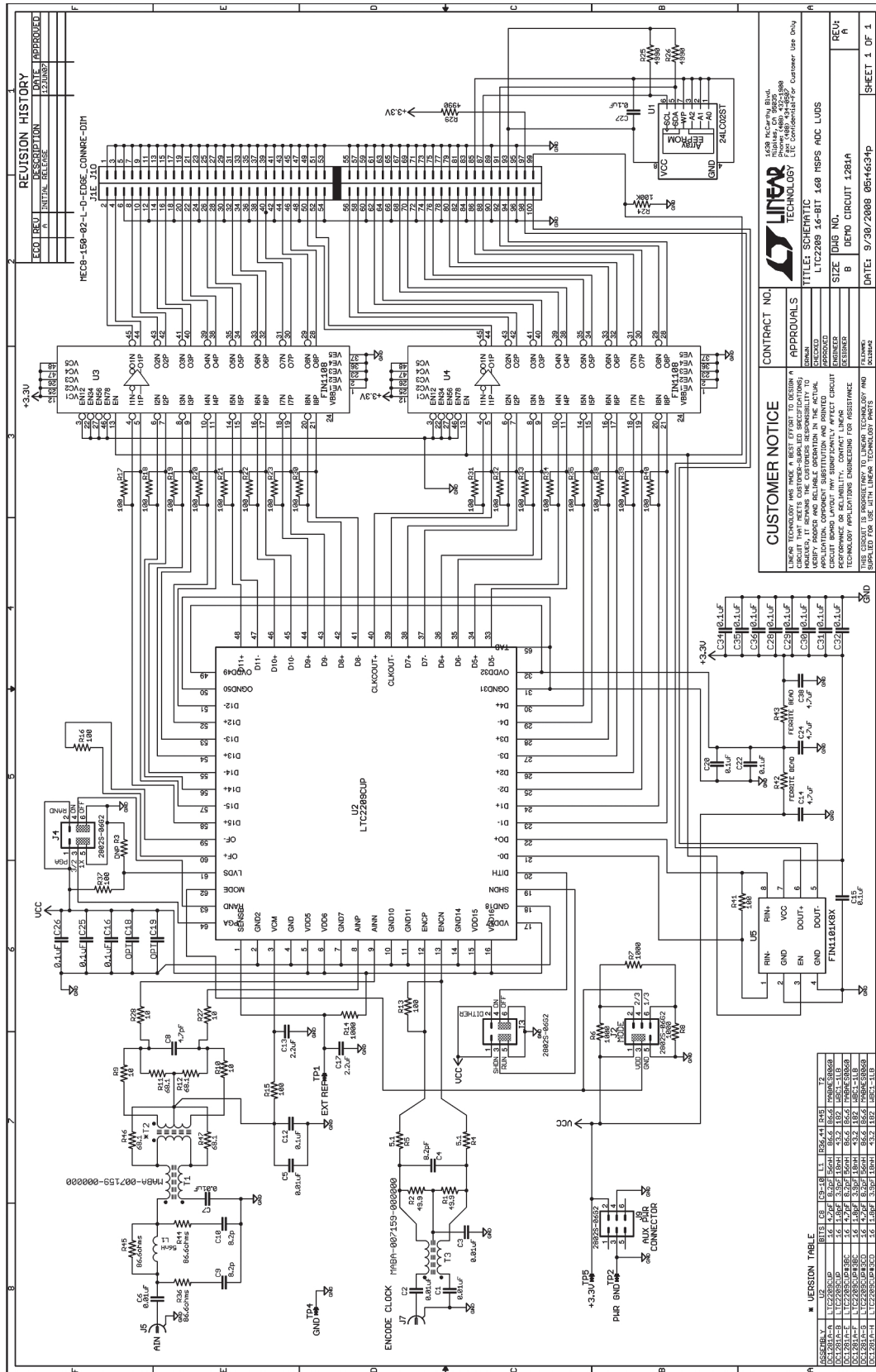

Information furnished by Linear Technology Corporation is believed to be accurate and reliable. However, no responsibility is assumed for its use. Linear Technology Corporation makes no representation that the interconnection of its circuits as described herein will not infringe on existing patent rights.

DEMO MANUAL DC1281A

DEMONSTRATION BOARD IMPORTANT NOTICE

Linear Technology Corporation (LTC) provides the enclosed product(s) under the following **AS IS** conditions:

This demonstration board (DEMO BOARD) kit being sold or provided by Linear Technology is intended for use for **ENGINEERING DEVELOPMENT OR EVALUATION PURPOSES ONLY** and is not provided by LTC for commercial use. As such, the DEMO BOARD herein may not be complete in terms of required design-, marketing-, and/or manufacturing-related protective considerations, including but not limited to product safety measures typically found in finished commercial goods. As a prototype, this product does not fall within the scope of the European Union directive on electromagnetic compatibility and therefore may or may not meet the technical requirements of the directive, or other regulations.

If this evaluation kit does not meet the specifications recited in the DEMO BOARD manual the kit may be returned within 30 days from the date of delivery for a full refund. **THE FOREGOING WARRANTY IS THE EXCLUSIVE WARRANTY MADE BY THE SELLER TO BUYER AND IS IN LIEU OF ALL OTHER WARRANTIES, EXPRESSED, IMPLIED, OR STATUTORY, INCLUDING ANY WARRANTY OF MERCHANTABILITY OR FITNESS FOR ANY PARTICULAR PURPOSE. EXCEPT TO THE EXTENT OF THIS INDEMNITY, NEITHER PARTY SHALL BE LIABLE TO THE OTHER FOR ANY INDIRECT, SPECIAL, INCIDENTAL, OR CONSEQUENTIAL DAMAGES.**

The user assumes all responsibility and liability for proper and safe handling of the goods. Further, the user releases LTC from all claims arising from the handling or use of the goods. Due to the open construction of the product, it is the user's responsibility to take any and all appropriate precautions with regard to electrostatic discharge. Also be aware that the products herein may not be regulatory compliant or agency certified (FCC, UL, CE, etc.).

No License is granted under any patent right or other intellectual property whatsoever. **LTC assumes no liability for applications assistance, customer product design, software performance, or infringement of patents or any other intellectual property rights of any kind.**

LTC currently services a variety of customers for products around the world, and therefore this transaction **is not exclusive**.

Please read the DEMO BOARD manual prior to handling the product. Persons handling this product must have electronics training and observe good laboratory practice standards. **Common sense is encouraged.**

This notice contains important safety information about temperatures and voltages. For further safety concerns, please contact a LTC application engineer.

Mailing Address:

Linear Technology
1630 McCarthy Blvd.
Milpitas, CA 95035

Copyright © 2004, Linear Technology Corporation



Компания «ЭлектроПласт» предлагает заключение долгосрочных отношений при поставках импортных электронных компонентов на взаимовыгодных условиях!

Наши преимущества:

- Оперативные поставки широкого спектра электронных компонентов отечественного и импортного производства напрямую от производителей и с крупнейших мировых складов;
- Поставка более 17-ти миллионов наименований электронных компонентов;
- Поставка сложных, дефицитных, либо снятых с производства позиций;
- Оперативные сроки поставки под заказ (от 5 рабочих дней);
- Экспресс доставка в любую точку России;
- Техническая поддержка проекта, помощь в подборе аналогов, поставка прототипов;
- Система менеджмента качества сертифицирована по Международному стандарту ISO 9001;
- Лицензия ФСБ на осуществление работ с использованием сведений, составляющих государственную тайну;
- Поставка специализированных компонентов (Xilinx, Altera, Analog Devices, Intersil, Interpoint, Microsemi, Aeroflex, Peregrine, Syfer, Eurofarad, Texas Instrument, Miteq, Cobham, E2V, MA-COM, Hittite, Mini-Circuits, General Dynamics и др.);

Помимо этого, одним из направлений компании «ЭлектроПласт» является направление «Источники питания». Мы предлагаем Вам помощь Конструкторского отдела:

- Подбор оптимального решения, техническое обоснование при выборе компонента;
- Подбор аналогов;
- Консультации по применению компонента;
- Поставка образцов и прототипов;
- Техническая поддержка проекта;
- Защита от снятия компонента с производства.



Как с нами связаться

Телефон: 8 (812) 309 58 32 (многоканальный)

Факс: 8 (812) 320-02-42

Электронная почта: org@eplast1.ru

Адрес: 198099, г. Санкт-Петербург, ул. Калинина, дом 2, корпус 4, литера А.