

HDSP-52xE Series HDSP-52xG Series HDSP-52xY Series

14.2 mm (0.56 inch) General Purpose
Two Digit Seven Segment Displays

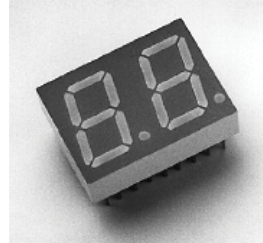

Data Sheet



Description

These 14.2 mm (0.56 inch) two digit displays use industry standard size and pin-out. The devices are available as either common anode or common cathode. These gray-faced displays are available in a choice of high efficiency red (HER), green, or yellow colors. The HDSP-521x and HDSP-523x series are suitable for indoor use.

These parts are subjected to Outgoing Quality Assurance (OQA) inspection with AQL of 0.065% for functional and visual/cosmetic rejects.

Applications

- Suitable for indoor use
- Not recommended for industrial applications, i.e. operating temperatures requirements exceeding 85° C or below -35° C [1]
- Extreme temperature cycling not recommended [2]

Features

- Industry standard size
- Industry standard pin-out 15.24 mm (0.6 in.) DIP leads on 2.54 mm (0.1 in.) centers
- Choice of colors
Red, green, yellow
- Mitered font
Mitered corners on segments
- Gray face paint
Gray package gives optimum contrast
- ±50° viewing angle
- Design flexibility
Common anode or common cathode
- Categorized for luminous intensity
- Green and yellow categorized for color

Devices

| HER HDSP- | Green HDSP- | Yellow HDSP- | Description |
|-----------|-------------|--------------|----------------------------------|
| 521E | 521G | 521Y | Common Anode Right Hand Decimal |
| 523E | 523G | 523Y | Common Cathode Right Hand Decima |

Notes:

1. For industrial applications, it is recommended to use HDSP-5521/5523/5621/5623/5721/5723.
2. For details, please contact your local Avago sales office or an authorized distributor.

Part Numbering System

5082 - X XX X - X X X XX
HDSP - X XX X - X X X XX

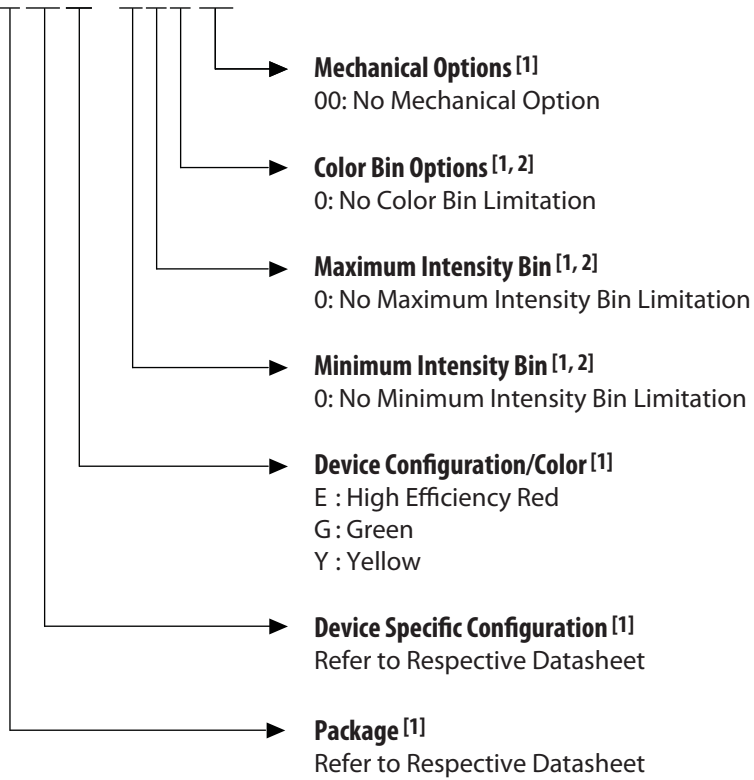

Notes:

1. For codes not listed in the figure above, please refer to the respective datasheet or contact your nearest Avago representative for details.
2. Bin options refer to shippable bins for a part number. Color and Intensity Bins are typically restricted to 1 bin per tube (exceptions may apply). Please refer to respective datasheet for specific bin limit information.

Package Dimensions

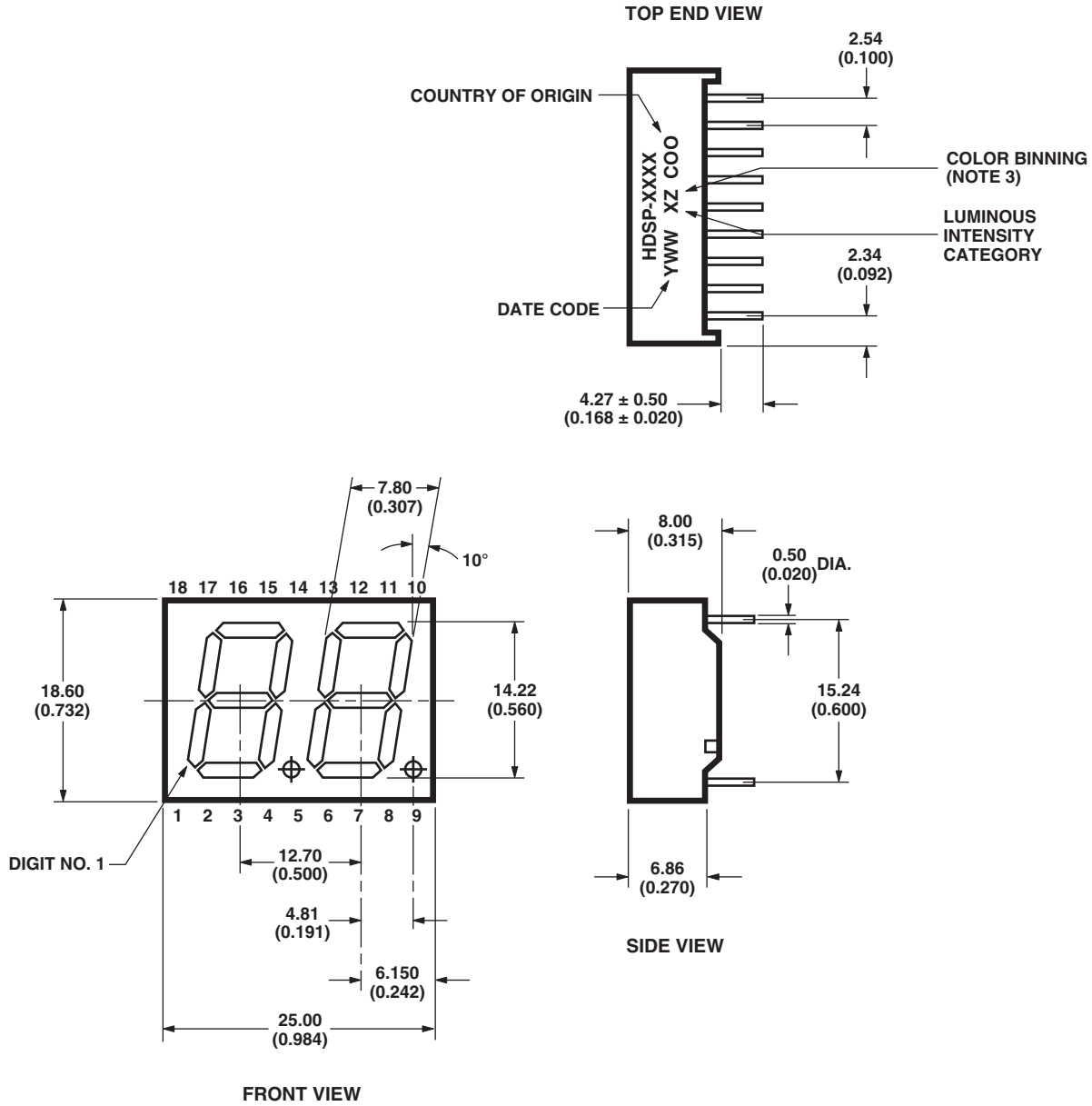

- NOTES:**
1. ALL DIMENSIONS ARE IN MILLIMETERS (INCHES).
 2. TOLERANCE IS 0.25 mm (0.01 INCH) UNLESS OTHERWISE STATED.
 3. FOR GREEN AND YELLOW ONLY.

Internal Circuit Diagram

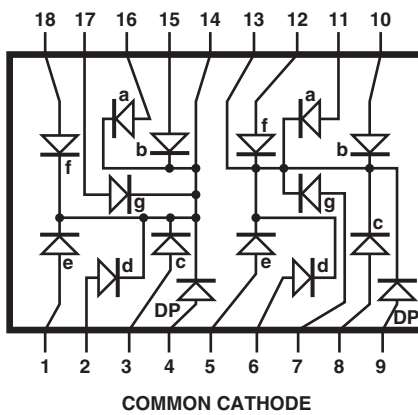
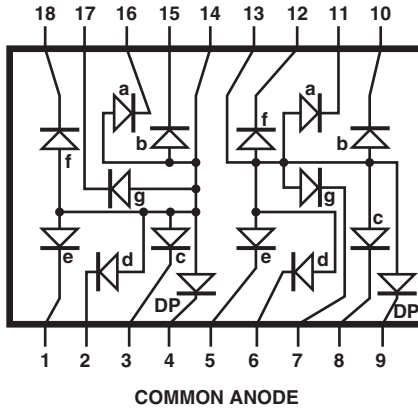

| COMMON ANODE | | COMMON CATHODE | |
|--------------|-------------------|----------------|---------------------|
| PIN | FUNCTION | PIN | FUNCTION |
| 1 | E CATHODE NO. 1 | 1 | E ANODE NO. 1 |
| 2 | D CATHODE NO. 1 | 2 | D ANODE NO. 1 |
| 3 | C CATHODE NO. 1 | 3 | C ANODE NO. 1 |
| 4 | DP CATHODE NO. 1 | 4 | DP ANODE NO. 1 |
| 5 | E CATHODE NO. 2 | 5 | E ANODE NO. 2 |
| 6 | D CATHODE NO. 2 | 6 | D ANODE NO. 2 |
| 7 | G CATHODE NO. 2 | 7 | G ANODE NO. 2 |
| 8 | C CATHODE NO. 2 | 8 | C ANODE NO. 2 |
| 9 | DP CATHODE NO. 2 | 9 | DP ANODE NO. 2 |
| 10 | B CATHODE NO. 2 | 10 | B ANODE NO. 2 |
| 11 | A CATHODE NO. 2 | 11 | A ANODE NO. 2 |
| 12 | F CATHODE NO. 2 | 12 | F ANODE NO. 2 |
| 13 | DIGIT NO. 2 ANODE | 13 | DIGIT NO. 2 CATHODE |
| 14 | DIGIT NO. 1 ANODE | 14 | DIGIT NO. 1 CATHODE |
| 15 | B CATHODE NO. 1 | 15 | B ANODE NO. 1 |
| 16 | A CATHODE NO. 1 | 16 | A ANODE NO. 1 |
| 17 | G CATHODE NO. 1 | 17 | G ANODE NO. 1 |
| 18 | F CATHODE NO. 1 | 18 | F ANODE NO. 1 |

Absolute Maximum Ratings at $T_A = 25^\circ\text{C}$

| Parameter | HER HDSP-521E HDSP-523E | Green HDSP-521G HDSP-523G | Yellow HDSP-521Y HDSP-523Y | Units |
|--|-------------------------------|---------------------------------|----------------------------------|------------------|
| Average Power per Segment or DP | 62.5 | 105 | 45 | mW |
| Peak Forward Current per Segment or DP (1/10 Duty Cycle, 0.1 ms Pulse Width) | 90 | 90 | 60 | mA |
| DC Forward Current per Segment or DP ^[1] | 25 ^[1] | 30 ^[3] | 20 ^[2] | mA |
| Reverse Voltage per Segment or DP | 5 | 5 | 5 | V |
| Operating Temperature | -35 to +85 | -35 to +85 | -35 to +85 | $^\circ\text{C}$ |
| Storage Temperature | -35 to +85 | -35 to +85 | -35 to +85 | $^\circ\text{C}$ |
| Wave Soldering Temperature for 3 seconds ^[4] (2 mm [0.063 in.] below Body) | 250 | 250 | 250 | $^\circ\text{C}$ |

Notes:

1. Derate above 25°C at $0.33\text{ mA}/^\circ\text{C}$.
2. Derate above 25°C at $0.27\text{ mA}/^\circ\text{C}$.
3. Derate above 40°C at $0.35\text{ mA}/^\circ\text{C}$.
4. Not recommended to be soldered more than 2 times. Minimum interval between solderings is 15 minutes. Total soldering time not to exceed 5 seconds.

Optical/Electrical Characteristics at $T_A=25^\circ\text{C}$

High Efficiency Red

| Devices HDSP- | Parameter | Symbol | Min. | Typ. | Max. | Units | Test Conditions |
|------------------|--|-----------------------------|------|------|------|----------------------|--------------------------|
| 521E 523E | Luminous Intensity/Segment (Segment Average) ^[1,2] | I_v | 2.28 | 4.00 | 7.69 | mcd | $I_F = 10\text{ mA}$ |
| | Forward Voltage/Segment or DP | V_F | | 2.05 | 2.60 | V | $I_F = 20\text{ mA}$ |
| | Peak Wavelength | λ_{PEAK} | | 640 | | nm | |
| | Dominant Wavelength ^[3] | λ_d | | 628 | | nm | $I_F = 10\text{ mA}$ |
| | Reverse Voltage/Segment or DP ^[4] | V_R | 5.0 | | | V | $I_R = 100\ \mu\text{A}$ |
| | Temperature Coefficient of V_F / Segment or DP | $\Delta V_F/^\circ\text{C}$ | | -2 | | mV/ $^\circ\text{C}$ | |

Green

| Devices HDSP- | Parameter | Symbol | Min. | Typ. | Max. | Units | Test Conditions |
|------------------|--|-----------------------------|-------|------|-------|----------------------|--------------------------|
| 521G 523G | Luminous Intensity/Segment (Segment Average) ^[1,2] | I_v | 2.28 | 3.50 | 5.13 | mcd | $I_F = 10\text{ mA}$ |
| | Forward Voltage/Segment or DP | V_F | | 2.0 | 2.4 | V | $I_F = 20\text{ mA}$ |
| | Peak Wavelength | λ_{PEAK} | | 568 | | nm | |
| | Dominant Wavelength ^[3] | λ_d | 564.5 | 570 | 576.5 | nm | $I_F = 10\text{ mA}$ |
| | Reverse Voltage/Segment or DP ^[4] | V_R | 5.0 | | | V | $I_R = 100\ \mu\text{A}$ |
| | Temperature Coefficient of V_F / Segment or DP | $\Delta V_F/^\circ\text{C}$ | | -2 | | mV/ $^\circ\text{C}$ | |

Yellow

| Devices | Parameter | Symbol | Min. | Typ. | Max. | Units | Test Conditions |
|--------------|--|-----------------------------|-------|------|-------|----------------------|-------------------------|
| 521Y 523Y | Luminous Intensity/Segment (Segment Average) ^[1,2] | I_V | 1.52 | 2.30 | 5.13 | mcd | $I_F = 10 \text{ mA}$ |
| | Forward Voltage/Segment or DP | V_F | | 2.1 | 2.4 | V | $I_F = 20 \text{ mA}$ |
| | Peak Wavelength | λ_{PEAK} | | 589 | | nm | |
| | Dominant Wavelength ^[3] | λ_d | 582.0 | 587 | 592.0 | nm | $I_F = 10 \text{ mA}$ |
| | Reverse Voltage/Segment or DP ^[4] | V_R | 5.0 | | | V | $I_R = 100 \mu\text{A}$ |
| | Temperature Coefficient of V_F / Segment or DP | $\Delta V_F/^\circ\text{C}$ | | -2 | | mV/ $^\circ\text{C}$ | |

Notes:

1. Case temperature of the device immediately prior to the intensity measurement is 25° C.
2. The digits are categorized for luminous intensity. The intensity category is designated by a letter on the side of the package.
3. The dominant wavelength, λ_d , is derived from the CIE chromaticity diagram and represents the single wavelength which defines the color of the device.
4. Typical specification for reference only. Do not exceed absolute maximum ratings.

Intensity Bin Limits^[1] (mcd at 10 mA)

| Bin Name | Yellow | | Green | | HER | |
|----------|---------------------|---------------------|---------------------|---------------------|---------------------|---------------------|
| | Min. ^[2] | Max. ^[2] | Min. ^[2] | Max. ^[2] | Min. ^[2] | Max. ^[2] |
| F | 1.52 | 2.28 | NA | NA | NA | NA |
| G | 2.28 | 3.42 | 2.28 | 3.42 | 2.28 | 3.42 |
| H | 3.42 | 5.13 | 3.42 | 5.13 | 3.42 | 5.13 |
| I | NA | NA | NA | NA | 5.13 | 7.69 |

Notes:

1. Bin categories are established for classification of products. Products may not be available in all bin categories.
2. Tolerance for each bin limit is $\pm 10\%$.

Color Categories (Dominant Wavelength)

| Green | | |
|----------|---------------------|---------------------|
| Bin Name | Min. ^[2] | Max. ^[2] |
| 3 | 570.5 | 573.5 |
| 2 | 573.5 | 576.5 |
| Yellow | | |
| Bin Name | Min. ^[2] | Max. ^[2] |
| 2 | 587.00 | 584.50 |
| 3 | 584.50 | 587.00 |

Notes:

1. Bin categories are established for classification of products. Products may not be available in all bin categories.
2. Tolerance for each bin limit is $\pm 1 \text{ nM}$.

Contrast Enhancement

For information on contrast enhancement, please see Application Note 1015.

Soldering/Cleaning

Cleaning agents from the ketone family (acetone, methyl ethyl ketone, etc.) and from the chlorinated hydrocarbon family (methylene chloride, trichloro-ethylene, carbon tetrachloride, etc.) are not recommended for cleaning LED parts. All of these various solvents attack or dissolve the encapsulating epoxies used to form the package of plastic LED parts.

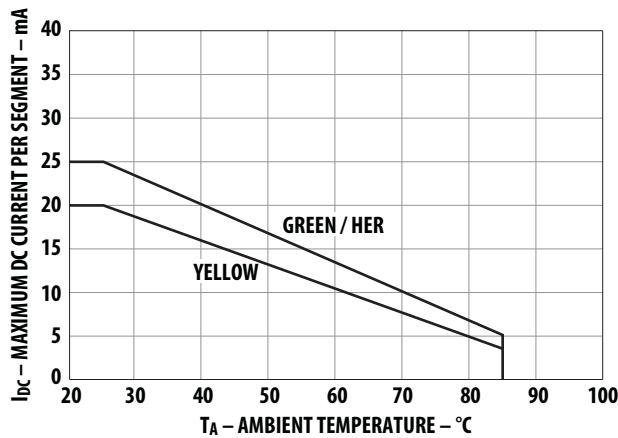

Figure 1. Maximum allowable DC current vs. ambient temperature.

For information on soldering LEDs please refer to Application Note 1027.

Device Reliability

For reliability information, please see the reliability data sheet 14.2 mm (0.56 inch) General Purpose Two Digit Seven Segment Display.

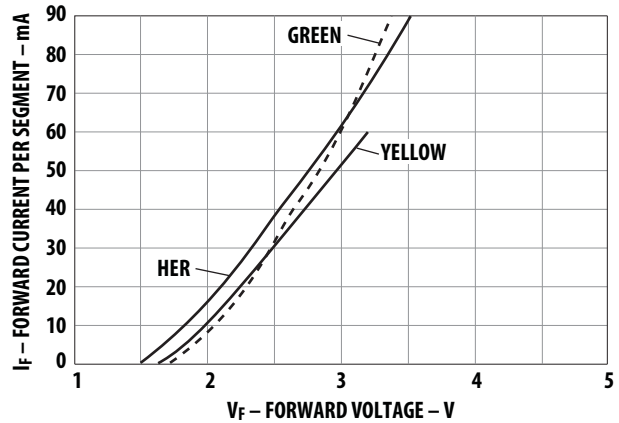

Figure 2. Forward current vs. forward voltage.

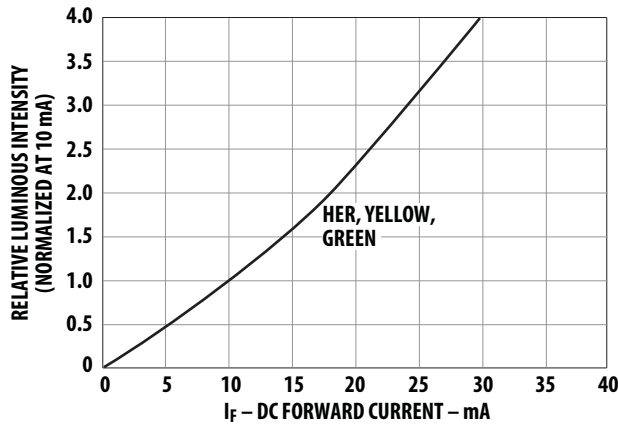

Figure 3. Relative luminous intensity vs. DC forward current.

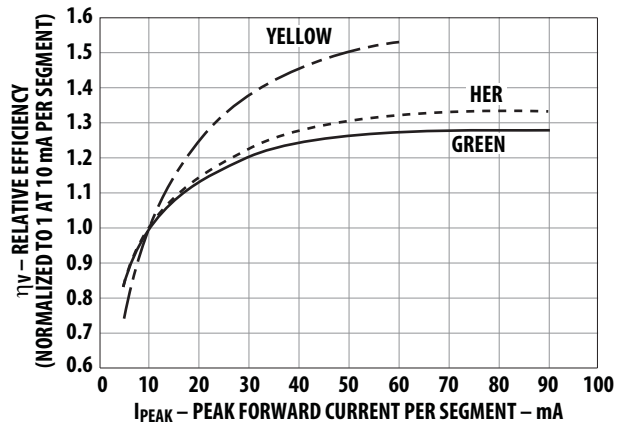

Figure 4. Relative efficiency (luminous intensity per unit current) vs. peak current.

For product information and a complete list of distributors, please go to our web site: www.avagotech.com

Avago, Avago Technologies, and the A logo are trademarks of Avago Technologies in the United States and other countries. Data subject to change. Copyright © 2005-2012 Avago Technologies. All rights reserved. Obsoletes 5988-5378EN AV02-3586EN - June 11, 2012

AVAGO
TECHNOLOGIES



Компания «ЭлектроПласт» предлагает заключение долгосрочных отношений при поставках импортных электронных компонентов на взаимовыгодных условиях!

Наши преимущества:

- Оперативные поставки широкого спектра электронных компонентов отечественного и импортного производства напрямую от производителей и с крупнейших мировых складов;
- Поставка более 17-ти миллионов наименований электронных компонентов;
- Поставка сложных, дефицитных, либо снятых с производства позиций;
- Оперативные сроки поставки под заказ (от 5 рабочих дней);
- Экспресс доставка в любую точку России;
- Техническая поддержка проекта, помощь в подборе аналогов, поставка прототипов;
- Система менеджмента качества сертифицирована по Международному стандарту ISO 9001;
- Лицензия ФСБ на осуществление работ с использованием сведений, составляющих государственную тайну;
- Поставка специализированных компонентов (Xilinx, Altera, Analog Devices, Intersil, Interpoint, Microsemi, Aeroflex, Peregrine, Syfer, Eurofarad, Texas Instrument, Miteq, Cobham, E2V, MA-COM, Hittite, Mini-Circuits, General Dynamics и др.);

Помимо этого, одним из направлений компании «ЭлектроПласт» является направление «Источники питания». Мы предлагаем Вам помощь Конструкторского отдела:

- Подбор оптимального решения, техническое обоснование при выборе компонента;
- Подбор аналогов;
- Консультации по применению компонента;
- Поставка образцов и прототипов;
- Техническая поддержка проекта;
- Защита от снятия компонента с производства.



Как с нами связаться

Телефон: 8 (812) 309 58 32 (многоканальный)

Факс: 8 (812) 320-02-42

Электронная почта: org@eplast1.ru

Адрес: 198099, г. Санкт-Петербург, ул. Калинина, дом 2, корпус 4, литера А.