

GD65232, GD75232 MULTIPLE RS-232 DRIVERS AND RECEIVERS

SLLS206S – MAY 1995 – REVISED AUGUST 2012

- **Single Chip With Easy Interface Between UART and Serial-Port Connector of IBM™ PC/AT and Compatibles**
- **Meet or Exceed the Requirements of TIA/EIA-232-F and ITU v.28 Standards**
- **Designed to Support Data Rates up to 120 kbit/s**
- **Pinout Compatible With SN75C185 and SN75185**
- **ESD Performance Tested Per JESD 22: HBM; 1500V, CDM: 500V, MM; 200V**

GD65232, GD75232 . . . DB, DW, N, OR PW PACKAGE (TOP VIEW)

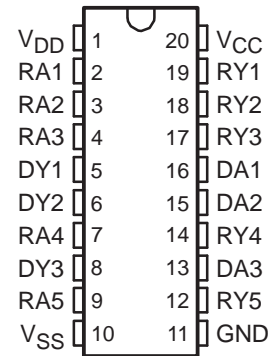

description/ordering information

The GD65232 and GD75232 combine three drivers and five receivers from the Texas Instruments trade-standard SN75188 and SN75189 bipolar quadruple drivers and receivers, respectively. The pinout matches the flow-through design of the SN75C185 to decrease the part count, reduce the board space required, and allow easy interconnection of the UART and serial-port connector of an IBM™ PC/AT and compatibles. The bipolar circuits and processing of the GD65232 and GD75232 provide a rugged, low-cost solution for this function at the expense of quiescent power and external passive components relative to the SN75C185.

The GD65232 and GD75232 comply with the requirements of the TIA/EIA-232-F and ITU (formerly CCITT) V.28 standards. These standards are for data interchange between a host computer and a peripheral at signaling rates up to 20 kbit/s. The switching speeds of these devices are fast enough to support rates up to 120 kbit/s with lower capacitive loads (shorter cables). Interoperability at the higher signaling rates cannot be expected unless the designer has design control of the cable and the interface circuits at both ends. For interoperability at signaling rates up to 120 kbit/s, use of TIA/EIA-423-B (ITU V.10) and TIA/EIA-422-B (ITU V.11) standards is recommended.

ORDERING INFORMATION

T _A	PACKAGE†		ORDERABLE PART NUMBER	TOP-SIDE MARKING
-40°C to 85°C	PDIP (N)	Tube of 20	GD65232N	GD65232N
	SOIC (DW)	Tube of 25	GD65232DW	GD65232
		Reel of 2000	GD65232DWR	
	SSOP (DB)	Reel of 2000	GD65232DBR	GD65232
	TSSOP (PW)	Tube of 70	GD65232PW	GD65232
		Reel of 2000	GD65232PWR	
0°C to 70°C	PDIP (N)	Tube of 20	GD75232N	GD75232N
	SOIC (DW)	Tube of 25	GD75232DW	GD75232
		Reel of 2000	GD75232DWR	
	SSOP (DB)	Reel of 2000	GD75232DBR	GD75232
	TSSOP (PW)	Tube of 70	GD75232PW	GD75232
		Reel of 2000	GD75232PWR	

† Package drawings, standard packing quantities, thermal data, symbolization, and PCB design guidelines are available at www.ti.com/sc/package.



Please be aware that an important notice concerning availability, standard warranty, and use in critical applications of Texas Instruments semiconductor products and disclaimers thereto appears at the end of this data sheet.

IBM is a trademark of International Business Machines Corporation.

PRODUCTION DATA information is current as of publication date. Products conform to specifications per the terms of Texas Instruments standard warranty. Production processing does not necessarily include testing of all parameters.



Copyright © 2004, Texas Instruments Incorporated

GD65232, GD75232 MULTIPLE RS-232 DRIVERS AND RECEIVERS

SLLS206S – MAY 1995 – REVISED 05/01/96

logic diagram (positive logic)

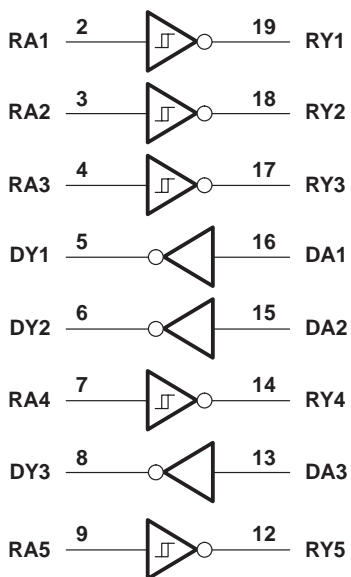

schematic (each driver)

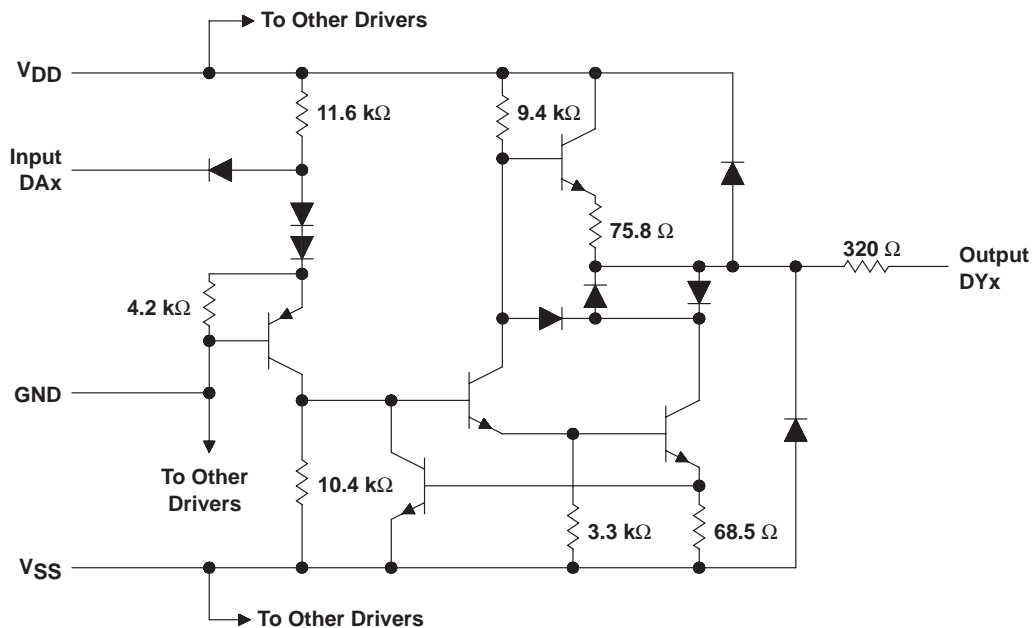

Resistor values shown are nominal.

schematic (each receiver)

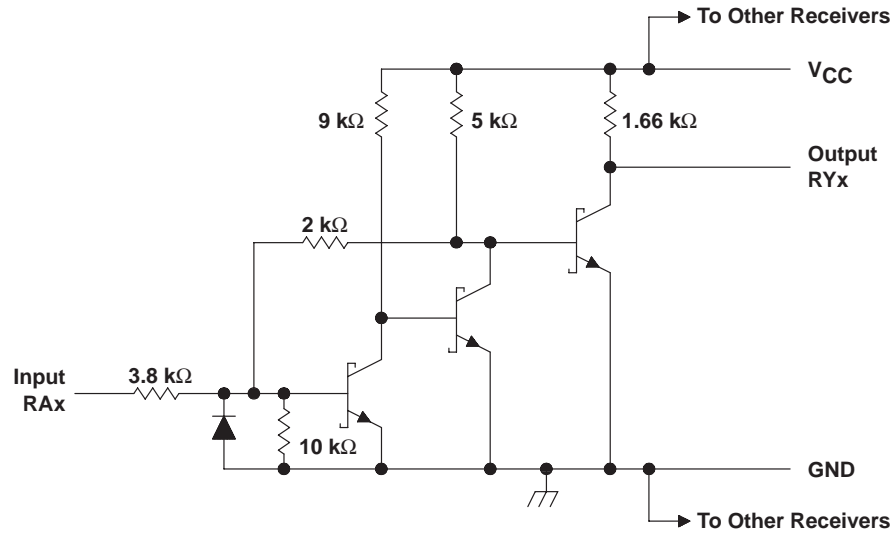

Resistor values shown are nominal.

absolute maximum ratings over operating free-air temperature range (unless otherwise noted)†

Supply voltage (see Note 1): V_{CC}	10 V
V_{DD}	15 V
V_{SS}	-15 V
Input voltage range, V_I : Driver	-15 V to 7 V
Receiver	-30 V to 30 V
Driver output voltage range, V_O	-15 V to 15 V
Receiver low-level output current, I_{OL}	20 mA
Package thermal impedance, θ_{JA} (see Notes 2 and 3): DB package	70°C/W
DW package	58°C/W
N package	69°C/W
PW package	83°C/W
Operating virtual junction temperature, T_J	150°C
Storage temperature range, T_{Stg}	-65°C to 150°C

† Stresses beyond those listed under "absolute maximum ratings" may cause permanent damage to the device. These are stress ratings only, and functional operation of the device at these or any other conditions beyond those indicated under "recommended operating conditions" is not implied. Exposure to absolute-maximum-rated conditions for extended periods may affect device reliability.

- NOTES: 1. All voltages are with respect to the network ground terminal.
 2. Maximum power dissipation is a function of $T_J(max)$, θ_{JA} , and T_A . The maximum allowable power dissipation at any allowable ambient temperature is $P_D = (T_J(max) - T_A)/\theta_{JA}$. Operating at the absolute maximum T_J of 150°C can affect reliability.
 3. The package thermal impedance is calculated in accordance with JESD 51-7.

GD65232, GD75232

MULTIPLE RS-232 DRIVERS AND RECEIVERS

SLLS206S – MAY 1995 – REVISED 05/01/00

recommended operating conditions

		MIN	NOM	MAX	UNIT
V _{DD}	Supply voltage (see Note 4)	7.5	9	15	V
V _{SS}	Supply voltage (see Note 4)	-7.5	-9	-15	V
V _{CC}	Supply voltage (see Note 4)	4.5	5	5.5	V
V _{IH}	High-level input voltage (driver only)	1.9			V
V _{IL}	Low-level input voltage (driver only)			0.8	V
I _{OH}	High-level output current	Driver		-6	mA
		Receiver		-0.5	
I _{OL}	Low-level output current	Driver		6	mA
		Receiver		16	
T _A	Operating free-air temperature	GD65232	-40	85	°C
		GD75232	0	70	

NOTE 4: When powering up the GD65232 and GD75232, the following sequence should be used:

1. V_{SS}
2. V_{DD}
3. V_{CC}
4. I/Os

Applying V_{CC} before V_{DD} may allow large currents to flow, causing damage to the device. When powering down the GD65232 and GD75232, the reverse sequence should be used.

supply currents over recommended operating free-air temperature range

PARAMETER		TEST CONDITIONS		MIN	MAX	UNIT
I _{DD}	Supply current from V _{DD}	All inputs at 1.9 V, No load	V _{DD} = 9 V, V _{SS} = -9 V		15	mA
			V _{DD} = 12 V, V _{SS} = -12 V		19	
			V _{DD} = 15 V, V _{SS} = -15 V		25	
		All inputs at 0.8 V, No load	V _{DD} = 9 V, V _{SS} = -9 V		4.5	
			V _{DD} = 12 V, V _{SS} = -12 V		5.5	
			V _{DD} = 15 V, V _{SS} = -15 V		9	
I _{SS}	Supply current from V _{SS}	All inputs at 1.9 V, No load	V _{DD} = 9 V, V _{SS} = -9 V		-15	mA
			V _{DD} = 12 V, V _{SS} = -12 V		-19	
			V _{DD} = 15 V, V _{SS} = -15 V		-25	
		All inputs at 0.8 V, No load	V _{DD} = 9 V, V _{SS} = -9 V		-3.2	
			V _{DD} = 12 V, V _{SS} = -12 V		-3.2	
			V _{DD} = 15 V, V _{SS} = -15 V		-3.2	
I _{CC}	Supply current from V _{CC}	All inputs at 5 V, No load, V _{CC} = 5 V	GD65232		38	mA
			GD75232		30	



DRIVER SECTION

electrical characteristics over recommended operating free-air temperature range, $V_{DD} = 9\text{ V}$, $V_{SS} = -9\text{ V}$, $V_{CC} = 5\text{ V}$ (unless otherwise noted)

PARAMETER		TEST CONDITIONS			MIN	TYP	MAX	UNIT
V_{OH}	High-level output voltage	$V_{IL} = 0.8\text{ V}$,	$R_L = 3\text{ k}\Omega$,	See Figure 1	6	7.5		V
V_{OL}	Low-level output voltage (see Note 5)	$V_{IH} = 1.9\text{ V}$,	$R_L = 3\text{ k}\Omega$,	See Figure 1		-7.5	-6	V
I_{IH}	High-level input current	$V_I = 5\text{ V}$,	See Figure 2				10	μA
I_{IL}	Low-level input current	$V_I = 0$,	See Figure 2				-1.6	mA
$I_{OS(H)}$	High-level short-circuit output current (see Note 6)	$V_{IL} = 0.8\text{ V}$,	$V_O = 0$,	See Figure 1	-4.5	-12	-19.5	mA
$I_{OS(L)}$	Low-level short-circuit output current	$V_{IH} = 2\text{ V}$,	$V_O = 0$,	See Figure 1	4.5	12	19.5	mA
r_o	Output resistance (see Note 7)	$V_{CC} = V_{DD} = V_{SS} = 0$,		$V_O = -2\text{ V to } 2\text{ V}$	300			Ω

- NOTES: 5. The algebraic convention, where the more positive (less negative) limit is designated as maximum, is used in this data sheet for logic levels only (e.g., if -10 V is maximum, the typical value is a more negative voltage).
6. Output short-circuit conditions must maintain the total power dissipation below absolute maximum ratings.
7. Test conditions are those specified by TIA/EIA-232-F and as listed above.

switching characteristics, $V_{CC} = 5\text{ V}$, $V_{DD} = 12\text{ V}$, $V_{SS} = -12\text{ V}$, $T_A = 25^\circ\text{C}$

PARAMETER		TEST CONDITIONS			MIN	TYP	MAX	UNIT
t_{PLH}	Propagation delay time, low- to high-level output	$R_L = 3\text{ k}\Omega$ to $7\text{ k}\Omega$,	$C_L = 15\text{ pF}$,	See Figure 3		315	500	ns
t_{PHL}	Propagation delay time, high- to low-level output	$R_L = 3\text{ k}\Omega$ to $7\text{ k}\Omega$,	$C_L = 15\text{ pF}$,	See Figure 3		75	175	ns
t_{TLH}	Transition time, low- to high-level output	$R_L = 3\text{ k}\Omega$ to $7\text{ k}\Omega$	$C_L = 15\text{ pF}$,	See Figure 3		60	100	ns
			$C_L = 2500\text{ pF}$,	See Figure 3 and Note 8		1.7	2.5	μs
t_{THL}	Transition time, high- to low-level output	$R_L = 3\text{ k}\Omega$ to $7\text{ k}\Omega$	$C_L = 15\text{ pF}$,	See Figure 3		40	75	ns
			$C_L = 2500\text{ pF}$,	See Figure 3 and Note 8		1.5	2.5	μs

NOTE 8: Measured between $\pm 3\text{-V}$ and $\pm 3\text{-V}$ points of the output waveform (TIA/EIA-232-F conditions); all unused inputs are tied either high or low.

GD65232, GD75232

MULTIPLE RS-232 DRIVERS AND RECEIVERS

SLLS206S – MAY 1995 – REVISED 05/01/00

RECEIVER SECTION

electrical characteristics over recommended operating conditions (unless otherwise noted)

PARAMETER		TEST CONDITIONS		MIN	TYP†	MAX	UNIT
V _{IT+}	Positive-going input threshold voltage	T _A = 25°C,	See Figure 5	1.75	1.9	2.3	V
		T _A = 0°C to 70°C,	See Figure 5	1.55		2.3	
V _{IT-}	Negative-going input threshold voltage			0.75	0.97	1.25	V
V _{hys}	Input hysteresis voltage (V _{IT+} - V _{IT-})			0.5			V
V _{OH}	High-level output voltage	I _{OH} = -0.5 mA	V _{IH} = 0.75 V	2.6	4	5	V
			Inputs open	2.6			
V _{OL}	Low-level output voltage	I _{OL} = 10 mA,	V _I = 3 V		0.2	0.45	V
I _{IH}	High-level input current	V _I = 25 V,	See Figure 5	GD65232	3.6	11	mA
				GD75232	3.6	8.3	
		V _I = 3 V,	See Figure 5		0.43		
I _{IL}	Low-level input current	V _I = -25 V,	See Figure 5	GD65232	-3.6	-11	mA
				GD75232	-3.6	-8.3	
		V _I = -3 V,	See Figure 5		-0.43		
I _{OS}	Short-circuit output current	See Figure 4			-3.4	-12	mA

† All typical values are at T_A = 25°C, V_{CC} = 5 V, V_{DD} = 9 V, and V_{SS} = -9 V.

switching characteristics, V_{CC} = 5 V, V_{DD} = 12 V, V_{SS} = -12 V, T_A = 25°C

PARAMETER		TEST CONDITIONS		MIN	TYP	MAX	UNIT
t _{PLH}	Propagation delay time, low- to high-level output	C _L = 50 pF, R _L = 5 kΩ, See Figure 6			107	250	ns
t _{PHL}	Propagation delay time, high- to low-level output				42	150	ns
t _{TLH}	Transition time, low- to high-level output				175	350	ns
t _{THL}	Transition time, high- to low-level output				16	60	ns
t _{PLH}	Propagation delay time, low- to high-level output	C _L = 15 pF, R _L = 1.5 kΩ, See Figure 6			100	160	ns
t _{PHL}	Propagation delay time, high- to low-level output				60	100	ns
t _{TLH}	Transition time, low- to high-level output				90	175	ns
t _{THL}	Transition time, high- to low-level output				15	50	ns



PARAMETER MEASUREMENT INFORMATION

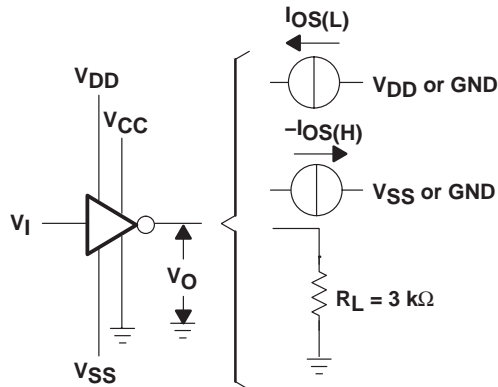

Figure 1. Driver Test Circuit for V_{OH} , V_{OL} , $I_{OS(H)}$, and $I_{OS(L)}$

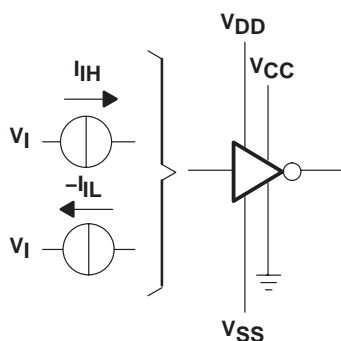
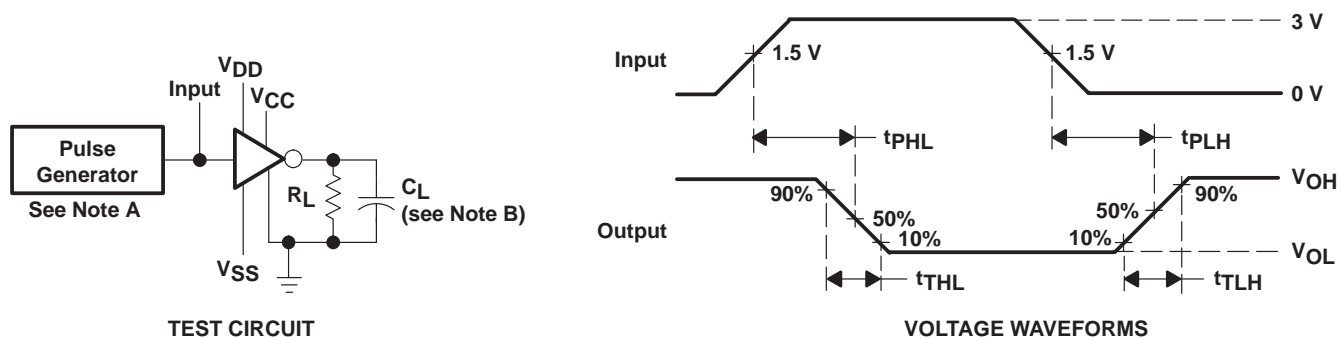

Figure 2. Driver Test Circuit for I_{iH} and I_{iL}



NOTES: A. The pulse generator has the following characteristics: $t_w = 25 \mu s$, $PRR = 20 \text{ kHz}$, $Z_O = 50 \Omega$, $t_r = t_f < 50 \text{ ns}$.
 B. C_L includes probe and jig capacitance.

Figure 3. Driver Test Circuit and Voltage Waveforms

GD65232, GD75232 MULTIPLE RS-232 DRIVERS AND RECEIVERS

SLLS206S – MAY 1995 – REVISED

PARAMETER MEASUREMENT INFORMATION

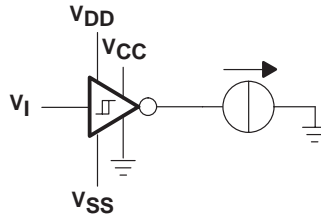

Figure 4. Receiver Test Circuit for I_{OS}

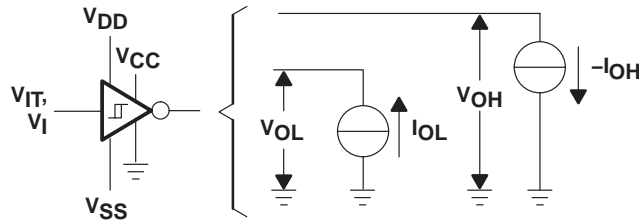
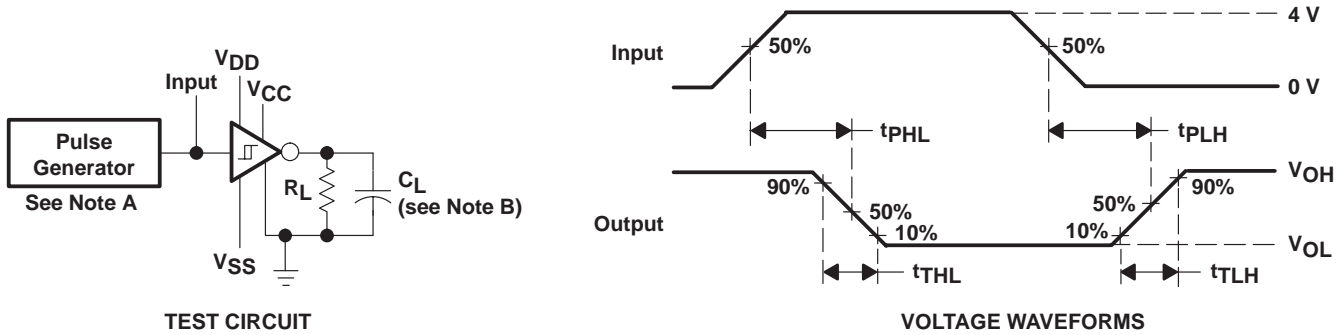

Figure 5. Receiver Test Circuit for V_{IT} , V_{OH} , and V_{OL}



- NOTES: A. The pulse generator has the following characteristics: $t_w = 25 \mu s$, $PRR = 20 \text{ kHz}$, $Z_O = 50 \Omega$, $t_r = t_f < 50 \text{ ns}$.
B. C_L includes probe and jig capacitance.

Figure 6. Receiver Propagation and Transition Times

TYPICAL CHARACTERISTICS

DRIVER SECTION

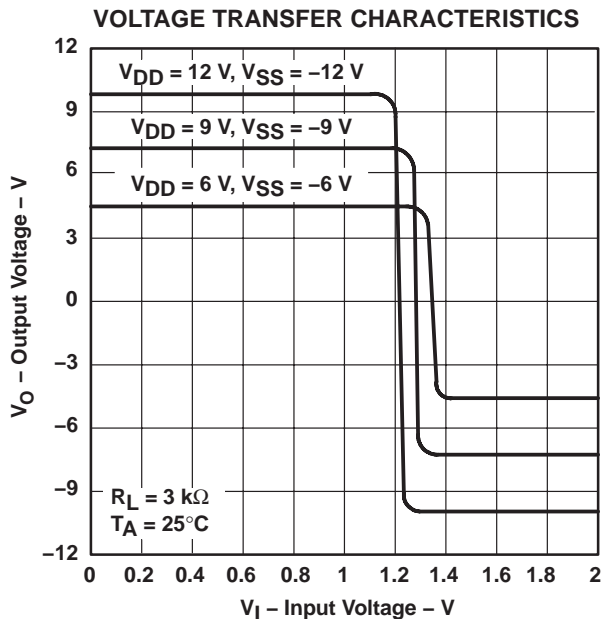

Figure 7

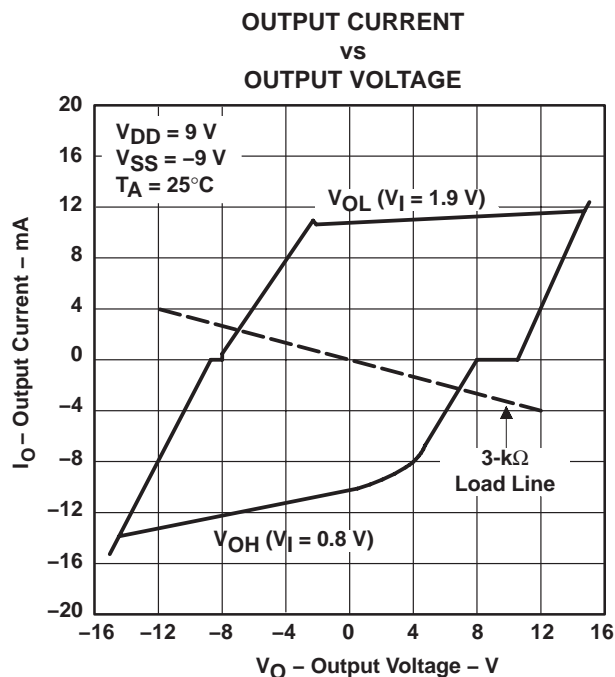

Figure 8

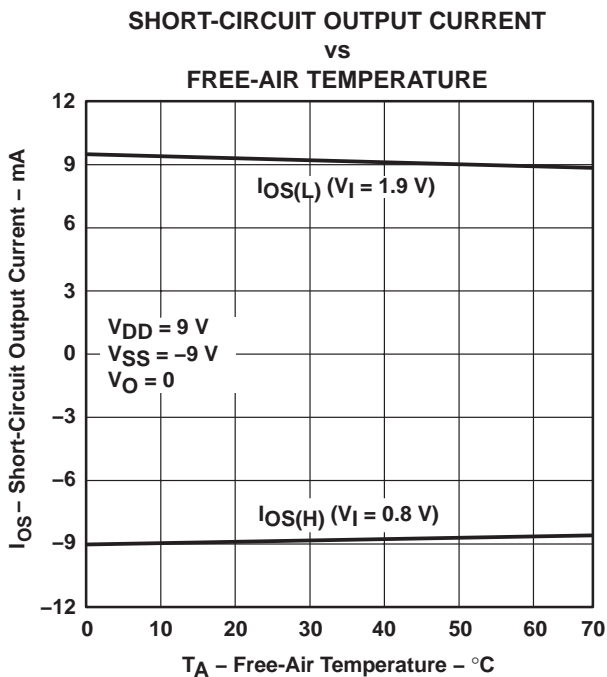

Figure 9

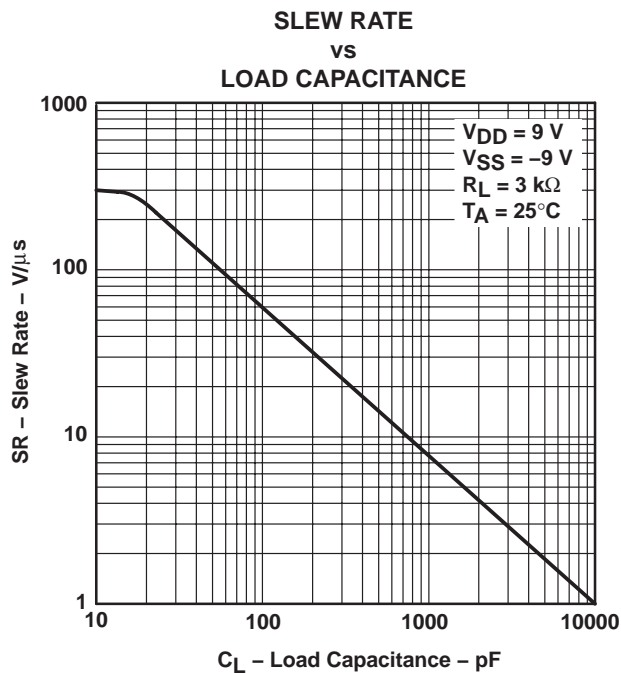

Figure 10

TYPICAL CHARACTERISTICS

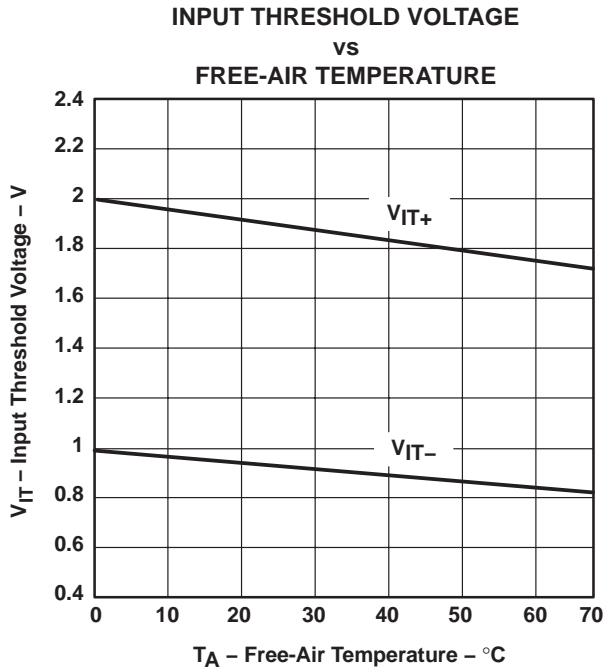

Figure 11

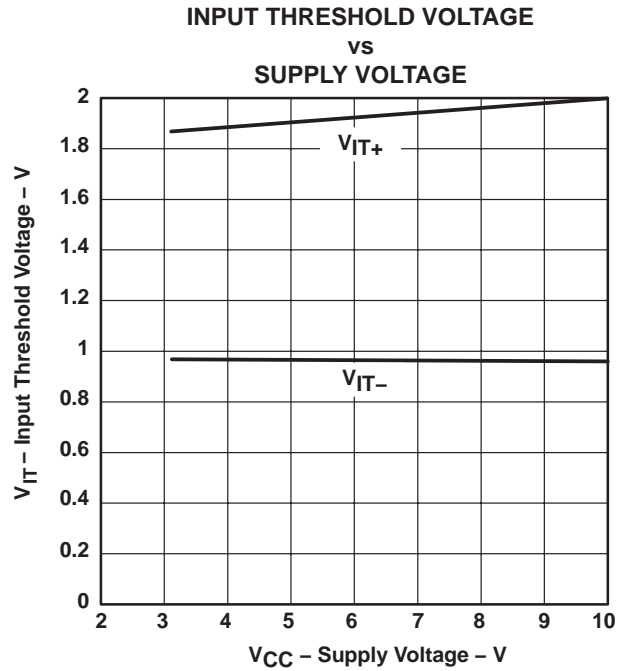
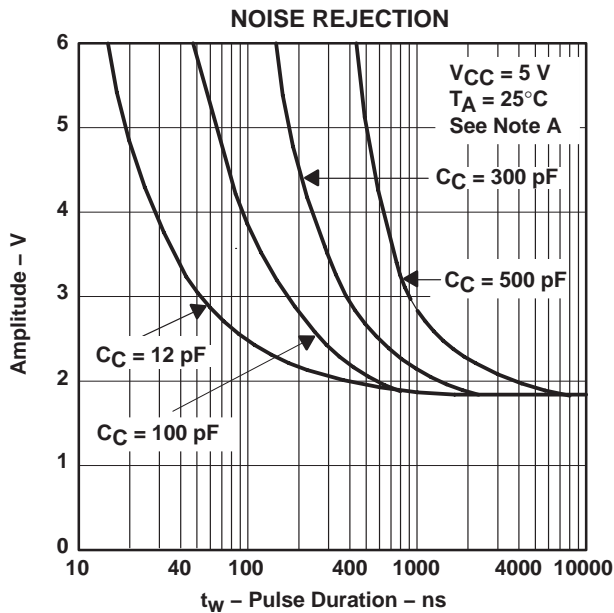

Figure 12



NOTE A: This figure shows the maximum amplitude of a positive-going pulse that, starting from 0 V, does not cause a change of the output level.

Figure 13

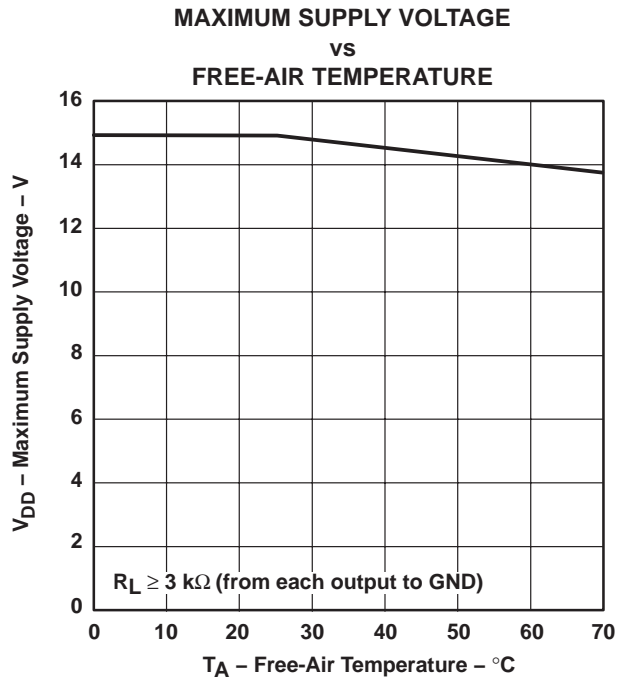

Figure 14

APPLICATION INFORMATION

Diodes placed in series with the V_{DD} and V_{SS} leads protect the GD65232 and GD75232 in the fault condition in which the device outputs are shorted to ± 15 V and the power supplies are at low and provide low-impedance paths to ground (see Figure 15).

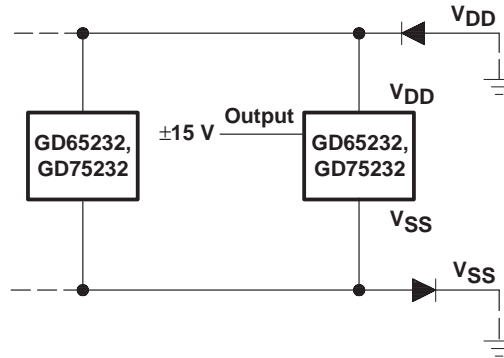

Figure 15. Power-Supply Protection to Meet Power-Off Fault Conditions of TIA/EIA-232-F

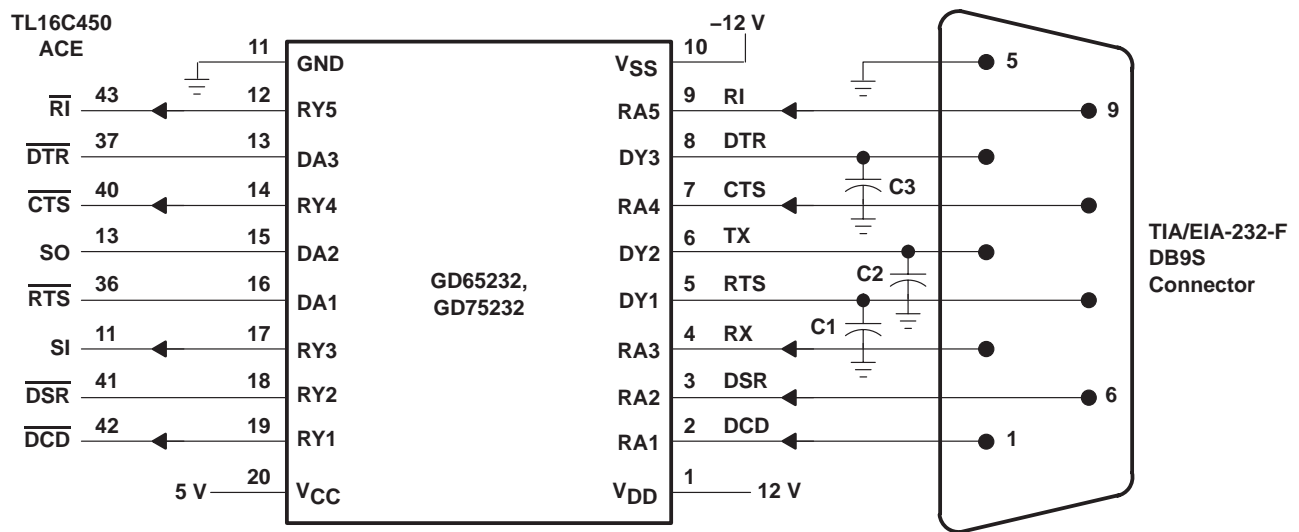

Figure 16. Typical Connection

PACKAGING INFORMATION

Orderable Device	Status (1)	Package Type	Package Drawing	Pins	Package Qty	Eco Plan (2)	Lead/Ball Finish	MSL Peak Temp (3)	Op Temp (°C)	Top-Side Markings (4)	Samples
GD65232DW	ACTIVE	SOIC	DW	20	25	Green (RoHS & no Sb/Br)	CU NIPDAU	Level-1-260C-UNLIM	-40 to 85	GD65232	Samples
GD65232DWE4	ACTIVE	SOIC	DW	20	25	Green (RoHS & no Sb/Br)	CU NIPDAU	Level-1-260C-UNLIM	-40 to 85	GD65232	Samples
GD65232DWG4	ACTIVE	SOIC	DW	20	25	Green (RoHS & no Sb/Br)	CU NIPDAU	Level-1-260C-UNLIM	-40 to 85	GD65232	Samples
GD65232DWR	ACTIVE	SOIC	DW	20	2000	Green (RoHS & no Sb/Br)	CU NIPDAU	Level-1-260C-UNLIM	-40 to 85	GD65232	Samples
GD65232DWRE4	ACTIVE	SOIC	DW	20	2000	Green (RoHS & no Sb/Br)	CU NIPDAU	Level-1-260C-UNLIM	-40 to 85	GD65232	Samples
GD65232DWRG4	ACTIVE	SOIC	DW	20	2000	Green (RoHS & no Sb/Br)	CU NIPDAU	Level-1-260C-UNLIM	-40 to 85	GD65232	Samples
GD65232PWR	ACTIVE	TSSOP	PW	20	2000	Green (RoHS & no Sb/Br)	CU NIPDAU	Level-1-260C-UNLIM	-40 to 85	GD65232	Samples
GD65232PWRE4	ACTIVE	TSSOP	PW	20	2000	Green (RoHS & no Sb/Br)	CU NIPDAU	Level-1-260C-UNLIM	-40 to 85	GD65232	Samples
GD65232PWRG4	ACTIVE	TSSOP	PW	20	2000	Green (RoHS & no Sb/Br)	CU NIPDAU	Level-1-260C-UNLIM	-40 to 85	GD65232	Samples
GD75232DBR	ACTIVE	SSOP	DB	20	2000	Green (RoHS & no Sb/Br)	CU NIPDAU	Level-1-260C-UNLIM	0 to 70	GD75232	Samples
GD75232DBRE4	ACTIVE	SSOP	DB	20	2000	Green (RoHS & no Sb/Br)	CU NIPDAU	Level-1-260C-UNLIM	0 to 70	GD75232	Samples
GD75232DBRG4	ACTIVE	SSOP	DB	20	2000	Green (RoHS & no Sb/Br)	CU NIPDAU	Level-1-260C-UNLIM	0 to 70	GD75232	Samples
GD75232DW	ACTIVE	SOIC	DW	20	25	Green (RoHS & no Sb/Br)	CU NIPDAU	Level-1-260C-UNLIM	0 to 70	GD75232	Samples
GD75232DWE4	ACTIVE	SOIC	DW	20	25	Green (RoHS & no Sb/Br)	CU NIPDAU	Level-1-260C-UNLIM	0 to 70	GD75232	Samples
GD75232DWG4	ACTIVE	SOIC	DW	20	25	Green (RoHS & no Sb/Br)	CU NIPDAU	Level-1-260C-UNLIM	0 to 70	GD75232	Samples
GD75232DWR	ACTIVE	SOIC	DW	20	2000	Green (RoHS & no Sb/Br)	CU NIPDAU	Level-1-260C-UNLIM	0 to 70	GD75232	Samples
GD75232DWRE4	ACTIVE	SOIC	DW	20	2000	Green (RoHS & no Sb/Br)	CU NIPDAU	Level-1-260C-UNLIM	0 to 70	GD75232	Samples

Orderable Device	Status (1)	Package Type	Package Drawing	Pins	Package Qty	Eco Plan (2)	Lead/Ball Finish	MSL Peak Temp (3)	Op Temp (°C)	Top-Side Markings (4)	Samples
GD75232DWRG4	ACTIVE	SOIC	DW	20	2000	Green (RoHS & no Sb/Br)	CU NIPDAU	Level-1-260C-UNLIM	0 to 70	GD75232	Samples
GD75232N	ACTIVE	PDIP	N	20	20	Pb-Free (RoHS)	CU NIPDAU	N / A for Pkg Type	0 to 70	GD75232N	Samples
GD75232NE4	ACTIVE	PDIP	N	20	20	Pb-Free (RoHS)	CU NIPDAU	N / A for Pkg Type	0 to 70	GD75232N	Samples
GD75232PW	ACTIVE	TSSOP	PW	20	70	Green (RoHS & no Sb/Br)	CU NIPDAU	Level-1-260C-UNLIM	0 to 70	GD75232	Samples
GD75232PWE4	ACTIVE	TSSOP	PW	20	70	Green (RoHS & no Sb/Br)	CU NIPDAU	Level-1-260C-UNLIM	0 to 70	GD75232	Samples
GD75232PWG4	ACTIVE	TSSOP	PW	20	70	Green (RoHS & no Sb/Br)	CU NIPDAU	Level-1-260C-UNLIM	0 to 70	GD75232	Samples
GD75232PWR	ACTIVE	TSSOP	PW	20	2000	Green (RoHS & no Sb/Br)	CU NIPDAU	Level-1-260C-UNLIM	0 to 70	GD75232	Samples
GD75232PWRE4	ACTIVE	TSSOP	PW	20		Green (RoHS & no Sb/Br)	CU NIPDAU	Level-1-260C-UNLIM	0 to 70	GD75232	Samples
GD75232PWRG4	ACTIVE	TSSOP	PW	20	2000	Green (RoHS & no Sb/Br)	CU NIPDAU	Level-1-260C-UNLIM	0 to 70	GD75232	Samples

(1) The marketing status values are defined as follows:

ACTIVE: Product device recommended for new designs.

LIFEBUY: TI has announced that the device will be discontinued, and a lifetime-buy period is in effect.

NRND: Not recommended for new designs. Device is in production to support existing customers, but TI does not recommend using this part in a new design.

PREVIEW: Device has been announced but is not in production. Samples may or may not be available.

OBSOLETE: TI has discontinued the production of the device.

(2) Eco Plan - The planned eco-friendly classification: Pb-Free (RoHS), Pb-Free (RoHS Exempt), or Green (RoHS & no Sb/Br) - please check <http://www.ti.com/productcontent> for the latest availability information and additional product content details.

TBD: The Pb-Free/Green conversion plan has not been defined.

Pb-Free (RoHS): TI's terms "Lead-Free" or "Pb-Free" mean semiconductor products that are compatible with the current RoHS requirements for all 6 substances, including the requirement that lead not exceed 0.1% by weight in homogeneous materials. Where designed to be soldered at high temperatures, TI Pb-Free products are suitable for use in specified lead-free processes.

Pb-Free (RoHS Exempt): This component has a RoHS exemption for either 1) lead-based flip-chip solder bumps used between the die and package, or 2) lead-based die adhesive used between the die and leadframe. The component is otherwise considered Pb-Free (RoHS compatible) as defined above.

Green (RoHS & no Sb/Br): TI defines "Green" to mean Pb-Free (RoHS compatible), and free of Bromine (Br) and Antimony (Sb) based flame retardants (Br or Sb do not exceed 0.1% by weight in homogeneous material)

(3) MSL, Peak Temp. -- The Moisture Sensitivity Level rating according to the JEDEC industry standard classifications, and peak solder temperature.

⁽⁴⁾ Only one of markings shown within the brackets will appear on the physical device.

Important Information and Disclaimer: The information provided on this page represents TI's knowledge and belief as of the date that it is provided. TI bases its knowledge and belief on information provided by third parties, and makes no representation or warranty as to the accuracy of such information. Efforts are underway to better integrate information from third parties. TI has taken and continues to take reasonable steps to provide representative and accurate information but may not have conducted destructive testing or chemical analysis on incoming materials and chemicals. TI and TI suppliers consider certain information to be proprietary, and thus CAS numbers and other limited information may not be available for release.

In no event shall TI's liability arising out of such information exceed the total purchase price of the TI part(s) at issue in this document sold by TI to Customer on an annual basis.

TAPE AND REEL INFORMATION

QUADRANT ASSIGNMENTS FOR PIN 1 ORIENTATION IN TAPE

*All dimensions are nominal

Device	Package Type	Package Drawing	Pins	SPQ	Reel Diameter (mm)	Reel Width W1 (mm)	A0 (mm)	B0 (mm)	K0 (mm)	P1 (mm)	W (mm)	Pin1 Quadrant
GD65232DWR	SOIC	DW	20	2000	330.0	24.4	10.8	13.0	2.7	12.0	24.0	Q1
GD65232PWR	TSSOP	PW	20	2000	330.0	16.4	6.95	7.1	1.6	8.0	16.0	Q1
GD75232DBR	SSOP	DB	20	2000	330.0	16.4	8.2	7.5	2.5	12.0	16.0	Q1
GD75232DWR	SOIC	DW	20	2000	330.0	24.4	10.8	13.0	2.7	12.0	24.0	Q1
GD75232PWR	TSSOP	PW	20	2000	330.0	16.4	6.95	7.1	1.6	8.0	16.0	Q1
GD75232PWR	TSSOP	PW	20	2000	330.0	16.4	6.95	7.1	1.6	8.0	16.0	Q1
GD75232PWRG4	TSSOP	PW	20	2000	330.0	16.4	6.95	7.1	1.6	8.0	16.0	Q1

TAPE AND REEL BOX DIMENSIONS

*All dimensions are nominal

Device	Package Type	Package Drawing	Pins	SPQ	Length (mm)	Width (mm)	Height (mm)
GD65232DWR	SOIC	DW	20	2000	367.0	367.0	45.0
GD65232PWR	TSSOP	PW	20	2000	367.0	367.0	38.0
GD75232DBR	SSOP	DB	20	2000	367.0	367.0	38.0
GD75232DWR	SOIC	DW	20	2000	367.0	367.0	45.0
GD75232PWR	TSSOP	PW	20	2000	367.0	367.0	38.0
GD75232PWR	TSSOP	PW	20	2000	364.0	364.0	27.0
GD75232PWRG4	TSSOP	PW	20	2000	367.0	367.0	38.0

N (R-PDIP-T**)

PLASTIC DUAL-IN-LINE PACKAGE

16 PINS SHOWN



- NOTES:
- A. All linear dimensions are in inches (millimeters).
 - B. This drawing is subject to change without notice.
 - C Falls within JEDEC MS-001, except 18 and 20 pin minimum body length (Dim A).
 - D The 20 pin end lead shoulder width is a vendor option, either half or full width.

4040049/E 12/2002

DW (R-PDSO-G20)

PLASTIC SMALL OUTLINE



- NOTES:
- A. All linear dimensions are in inches (millimeters). Dimensioning and tolerancing per ASME Y14.5M-1994.
 - B. This drawing is subject to change without notice.
 - C. Body dimensions do not include mold flash or protrusion not to exceed 0.006 (0,15).
 - D. Falls within JEDEC MS-013 variation AC.

DW (R-PDSO-G20)

PLASTIC SMALL OUTLINE

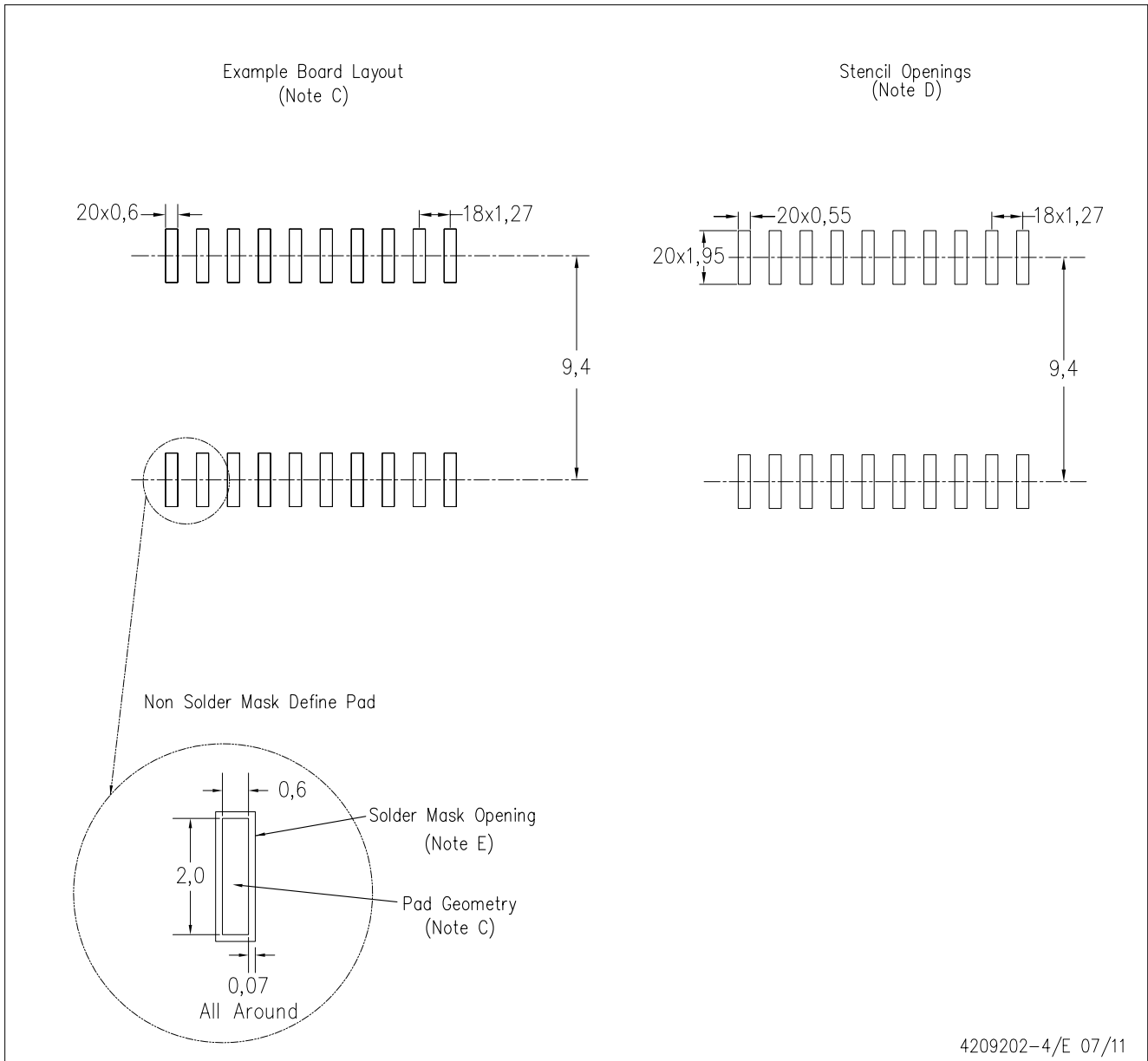

4209202-4/E 07/11

- NOTES:
- A. All linear dimensions are in millimeters.
 - B. This drawing is subject to change without notice.
 - C. Refer to IPC7351 for alternate board design.
 - D. Laser cutting apertures with trapezoidal walls and also rounding corners will offer better paste release. Customers should contact their board assembly site for stencil design recommendations. Refer to IPC-7525
 - E. Customers should contact their board fabrication site for solder mask tolerances between and around signal pads.

PW (R-PDSO-G20)

PLASTIC SMALL OUTLINE

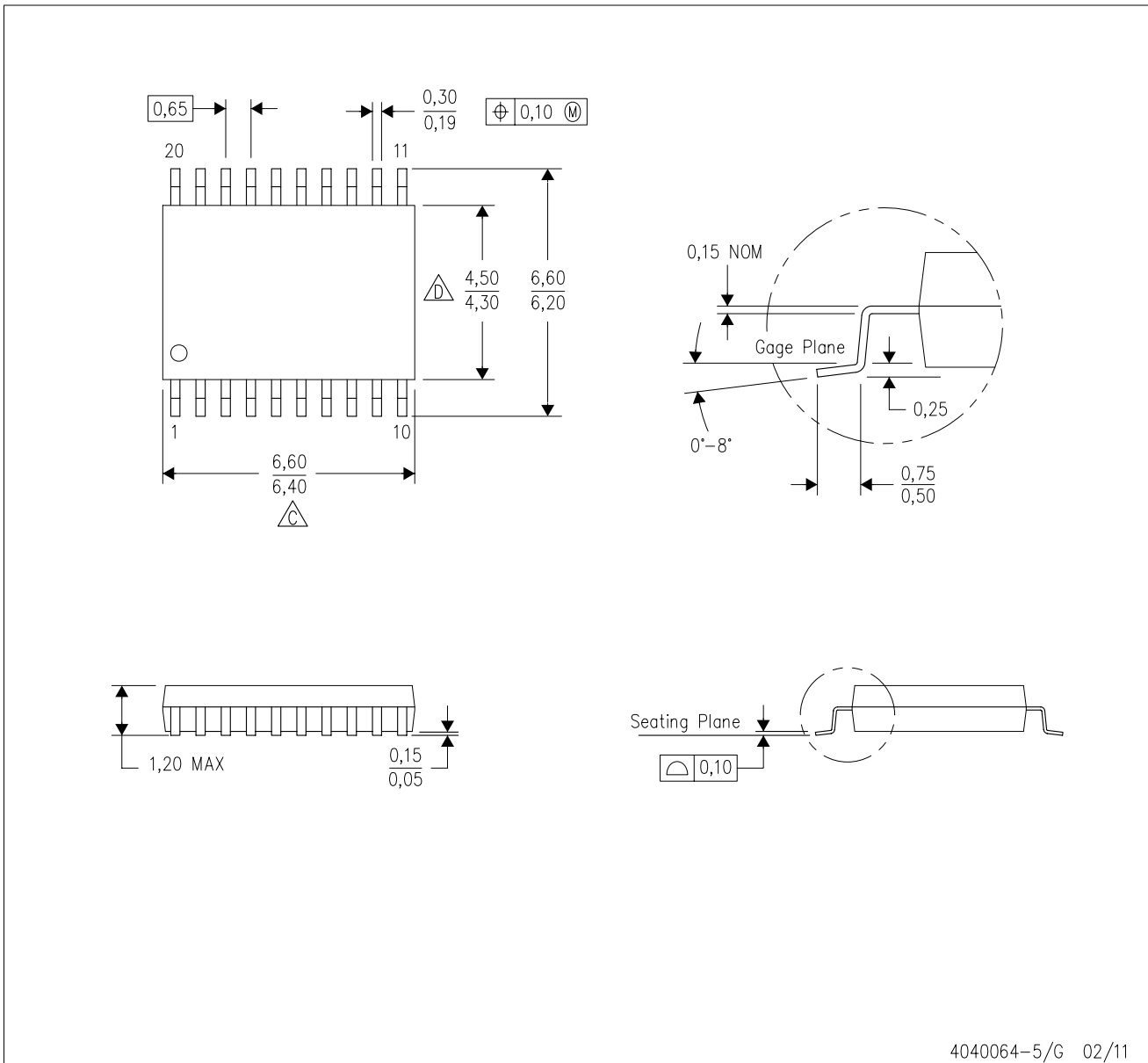

- NOTES:
- All linear dimensions are in millimeters. Dimensioning and tolerancing per ASME Y14.5M-1994.
 - This drawing is subject to change without notice.
 - Body length does not include mold flash, protrusions, or gate burrs. Mold flash, protrusions, or gate burrs shall not exceed 0,15 each side.
 - Body width does not include interlead flash. Interlead flash shall not exceed 0,25 each side.
 - Falls within JEDEC MO-153

PW (R-PDSO-G20)

PLASTIC SMALL OUTLINE



- NOTES:
- A. All linear dimensions are in millimeters.
 - B. This drawing is subject to change without notice.
 - C. Publication IPC-7351 is recommended for alternate design.
 - D. Laser cutting apertures with trapezoidal walls and also rounding corners will offer better paste release. Customers should contact their board assembly site for stencil design recommendations. Refer to IPC-7525 for other stencil recommendations.
 - E. Customers should contact their board fabrication site for solder mask tolerances between and around signal pads.

DB (R-PDSO-G**)

PLASTIC SMALL-OUTLINE

28 PINS SHOWN



- NOTES: A. All linear dimensions are in millimeters.
 B. This drawing is subject to change without notice.
 C. Body dimensions do not include mold flash or protrusion not to exceed 0,15.
 D. Falls within JEDEC MO-150

IMPORTANT NOTICE

Texas Instruments Incorporated and its subsidiaries (TI) reserve the right to make corrections, enhancements, improvements and other changes to its semiconductor products and services per JESD46, latest issue, and to discontinue any product or service per JESD48, latest issue. Buyers should obtain the latest relevant information before placing orders and should verify that such information is current and complete. All semiconductor products (also referred to herein as "components") are sold subject to TI's terms and conditions of sale supplied at the time of order acknowledgment.

TI warrants performance of its components to the specifications applicable at the time of sale, in accordance with the warranty in TI's terms and conditions of sale of semiconductor products. Testing and other quality control techniques are used to the extent TI deems necessary to support this warranty. Except where mandated by applicable law, testing of all parameters of each component is not necessarily performed.

TI assumes no liability for applications assistance or the design of Buyers' products. Buyers are responsible for their products and applications using TI components. To minimize the risks associated with Buyers' products and applications, Buyers should provide adequate design and operating safeguards.

TI does not warrant or represent that any license, either express or implied, is granted under any patent right, copyright, mask work right, or other intellectual property right relating to any combination, machine, or process in which TI components or services are used. Information published by TI regarding third-party products or services does not constitute a license to use such products or services or a warranty or endorsement thereof. Use of such information may require a license from a third party under the patents or other intellectual property of the third party, or a license from TI under the patents or other intellectual property of TI.

Reproduction of significant portions of TI information in TI data books or data sheets is permissible only if reproduction is without alteration and is accompanied by all associated warranties, conditions, limitations, and notices. TI is not responsible or liable for such altered documentation. Information of third parties may be subject to additional restrictions.

Resale of TI components or services with statements different from or beyond the parameters stated by TI for that component or service voids all express and any implied warranties for the associated TI component or service and is an unfair and deceptive business practice. TI is not responsible or liable for any such statements.

Buyer acknowledges and agrees that it is solely responsible for compliance with all legal, regulatory and safety-related requirements concerning its products, and any use of TI components in its applications, notwithstanding any applications-related information or support that may be provided by TI. Buyer represents and agrees that it has all the necessary expertise to create and implement safeguards which anticipate dangerous consequences of failures, monitor failures and their consequences, lessen the likelihood of failures that might cause harm and take appropriate remedial actions. Buyer will fully indemnify TI and its representatives against any damages arising out of the use of any TI components in safety-critical applications.

In some cases, TI components may be promoted specifically to facilitate safety-related applications. With such components, TI's goal is to help enable customers to design and create their own end-product solutions that meet applicable functional safety standards and requirements. Nonetheless, such components are subject to these terms.

No TI components are authorized for use in FDA Class III (or similar life-critical medical equipment) unless authorized officers of the parties have executed a special agreement specifically governing such use.

Only those TI components which TI has specifically designated as military grade or "enhanced plastic" are designed and intended for use in military/aerospace applications or environments. Buyer acknowledges and agrees that any military or aerospace use of TI components which have **not** been so designated is solely at the Buyer's risk, and that Buyer is solely responsible for compliance with all legal and regulatory requirements in connection with such use.

TI has specifically designated certain components as meeting ISO/TS16949 requirements, mainly for automotive use. In any case of use of non-designated products, TI will not be responsible for any failure to meet ISO/TS16949.

Products

Audio	www.ti.com/audio
Amplifiers	amplifier.ti.com
Data Converters	dataconverter.ti.com
DLP® Products	www.dlp.com
DSP	dsp.ti.com
Clocks and Timers	www.ti.com/clocks
Interface	interface.ti.com
Logic	logic.ti.com
Power Mgmt	power.ti.com
Microcontrollers	microcontroller.ti.com
RFID	www.ti-rfid.com
OMAP Applications Processors	www.ti.com/omap
Wireless Connectivity	www.ti.com/wirelessconnectivity

Applications

Automotive and Transportation	www.ti.com/automotive
Communications and Telecom	www.ti.com/communications
Computers and Peripherals	www.ti.com/computers
Consumer Electronics	www.ti.com/consumer-apps
Energy and Lighting	www.ti.com/energy
Industrial	www.ti.com/industrial
Medical	www.ti.com/medical
Security	www.ti.com/security
Space, Avionics and Defense	www.ti.com/space-avionics-defense
Video and Imaging	www.ti.com/video

TI E2E Community

e2e.ti.com



Компания «ЭлектроПласт» предлагает заключение долгосрочных отношений при поставках импортных электронных компонентов на взаимовыгодных условиях!

Наши преимущества:

- Оперативные поставки широкого спектра электронных компонентов отечественного и импортного производства напрямую от производителей и с крупнейших мировых складов;
- Поставка более 17-ти миллионов наименований электронных компонентов;
- Поставка сложных, дефицитных, либо снятых с производства позиций;
- Оперативные сроки поставки под заказ (от 5 рабочих дней);
- Экспресс доставка в любую точку России;
- Техническая поддержка проекта, помощь в подборе аналогов, поставка прототипов;
- Система менеджмента качества сертифицирована по Международному стандарту ISO 9001;
- Лицензия ФСБ на осуществление работ с использованием сведений, составляющих государственную тайну;
- Поставка специализированных компонентов (Xilinx, Altera, Analog Devices, Intersil, Interpoint, Microsemi, Aeroflex, Peregrine, Syfer, Eurofarad, Texas Instrument, Miteq, Cobham, E2V, MA-COM, Hittite, Mini-Circuits, General Dynamics и др.);

Помимо этого, одним из направлений компании «ЭлектроПласт» является направление «Источники питания». Мы предлагаем Вам помощь Конструкторского отдела:

- Подбор оптимального решения, техническое обоснование при выборе компонента;
- Подбор аналогов;
- Консультации по применению компонента;
- Поставка образцов и прототипов;
- Техническая поддержка проекта;
- Защита от снятия компонента с производства.



Как с нами связаться

Телефон: 8 (812) 309 58 32 (многоканальный)

Факс: 8 (812) 320-02-42

Электронная почта: org@eplast1.ru

Адрес: 198099, г. Санкт-Петербург, ул. Калинина, дом 2, корпус 4, литера А.