

Features

- Incorporates the ARM7TDMI® ARM® Thumb® Processor Core
 - High-performance 32-bit RISC Architecture
 - High-density 16-bit Instruction Set
 - Leader in MIPS/Watt
 - Embedded ICE (In-Circuit Emulation)
- 8K Bytes On-chip SRAM
 - 32-bit Data Bus
 - Single-clock Cycle Access
- Fully-programmable External Bus Interface (EBI)
 - Maximum External Address Space of 64M Bytes
 - Up to 8 Chip Selects
 - Software Programmable 8-/16-bit External Data Bus
- 8-level Priority, Individually Maskable, Vectored Interrupt Controller
 - 4 External Interrupts, Including a High-priority Low-latency Interrupt Request
- 32 Programmable I/O Lines
- 3-channel 16-bit Timer/Counter
 - 3 External Clock Inputs
 - 2 Multi-purpose I/O Pins per Channel
- 2 USARTs
 - 2 Dedicated Peripheral Data Controller (PDC) Channels per USART
- Programmable Watchdog Timer
- Advanced Power-saving Features
 - CPU and Peripheral Can be Deactivated Individually
- Fully Static Operation: 0 Hz to 40 MHz Internal Frequency Range at 3.0 V, 85°C
- 1.8V to 3.6V Operating Range
- Available in a 100-lead TQFP Package

Description

The AT91M40800 microcontroller is a member of the Atmel AT91 16-/32-bit microcontroller family, which is based on the ARM7TDMI processor core. This processor has a high-performance 32-bit RISC architecture with a high-density 16-bit instruction set and very low power consumption. In addition, a large number of internally banked registers result in very fast exception handling, making the device ideal for real-time control applications.

The AT91M40800 microcontroller features a direct connection to off-chip memory, including Flash, through the fully-programmable External Bus Interface (EBI). An eight-level priority vectored interrupt controller, in conjunction with the Peripheral Data Controller, significantly improves the real-time performance of the device.

The device is manufactured using Atmel's high-density CMOS technology. By combining the ARM7TDMI processor core with on-chip high-speed memory and a wide range of peripheral functions on a monolithic chip, the AT91M40800 is a powerful microcontroller that offers a flexible, cost-effective solution to many compute-intensive embedded control applications.



AT91 ARM® Thumb® Microcontrollers

AT91M40800 Electrical Characteristics





Absolute Maximum Ratings*

| | |
|--|--------------------|
| Operating Temperature (Industrial) .. | -40° C to + 85° C |
| Storage Temperature | -60° C to + 150° C |
| Voltage on Any Input Pin with Respect to Ground | -0.5V to + 5.5V |
| Maximum Operating Voltage | 4.6V |
| DC Output Current | 6 mA |

*NOTICE: Stresses beyond those listed under “Absolute Maximum Ratings” may cause permanent damage to the device. This is a stress rating only and functional operation of the device at these or other conditions beyond those indicated in the operational sections of this specification is not implied. Exposure to absolute maximum rating conditions for extended periods may affect device reliability.

The following characteristics are applicable to the Operating Temperature range: $T_A = -40^\circ\text{C}$ to $+85^\circ\text{C}$, unless otherwise specified and are certified for a Junction Temperature up to $T_J = 100^\circ\text{C}$.

Table 1. DC Characteristics

| Symbol | Parameter | Conditions | Min | Typ | Max | Units |
|------------|-----------------------|--|--------------------------|-----|------|---------------|
| V_{DD} | DC Supply | | 1.8 | | 3.6 | V |
| V_{IL} | Input Low Voltage | $V_{DD} = 3.3\text{V}$ | | | 0.8 | V |
| V_{IH} | Input High Voltage | $V_{DD} = 3.3\text{V}$ | 2.0 | | | V |
| V_{OL} | Output Low Voltage | $I_{OL} = 2.0\text{ mA}, V_{DD} = 3.3\text{V}$ | | | 0.4 | V |
| V_{OH} | Output High Voltage | $I_{OH} = 2.0\text{ mA}, V_{DD} = 3.3\text{V}$ | 2.4 | | | V |
| I_{LEAK} | Input Leakage Current | | | | 4 | μA |
| I_{PULL} | Input Pull-up Current | $V_{DD} = 3.6\text{V}, V_{IN} = 0\text{V}$ | | | 350 | μA |
| C_{IN} | Input Capacitance | | | | 6.6 | pF |
| I_{SC} | Static Current | $V_{DD} = 3.6\text{V}; \text{MCKI} = 0\text{ Hz}$ All inputs driven $\text{TMS, TDI, TCK, NRST} = 1$ | $T_A = 25^\circ\text{C}$ | | 12.5 | μA |
| | | | $T_A = 85^\circ\text{C}$ | | 250 | |

Power Consumption

The values in the following tables are measured values in the operating conditions indicated (i.e., $V_{DD} = 3.3V$ or $2.0V$, $T_A = 25^\circ C$) on the AT91EB40 Evaluation Board.

Table 2. Power Consumption

| Mode | Conditions | V_{DD} | | Unit |
|--------|---|----------|------|--------|
| | | 2.0V | 3.3V | |
| Reset | | 0.06 | 0.10 | mW/MHz |
| Normal | Fetch in ARM mode out of internal SRAM All peripheral clocks activated | 1.38 | 4.63 | |
| | Fetch in ARM mode out of internal SRAM All peripheral clocks deactivated | 1.04 | 3.44 | |
| Idle | All peripheral clocks activated | 0.61 | 2.06 | |
| | All peripheral clocks deactivated | 0.19 | 0.79 | |

Table 3. Power Consumption per Peripheral

| Peripheral | V_{DD} | | Unit |
|----------------------------------|----------|------|--------|
| | 2.0V | 3.3V | |
| PIO Controller | 0.01 | 0.16 | mW/MHz |
| Timer/Counter Channel | 0.01 | 0.15 | |
| Timer/Counter Block (3 Channels) | 0.02 | 0.35 | |
| USART | 0.03 | 0.40 | |

Thermal and Reliability Considerations

Thermal Data

In Table 4, the device lifetime is estimated with the MIL-217 standard in the “moderately controlled” environmental model (this model is described as corresponding to an installation in a permanent rack with adequate cooling air), depending on the device Junction Temperature. (For details see the section “Junction Temperature” on page 5.)

Note that the user must be extremely cautious with this MTBF calculation: as the MIL-217 model is pessimistic with respect to observed values due to the way the data/models are obtained (test under severe conditions). The life test results that have been measured are always better than the predicted ones.

Table 4. MTBF Versus Junction Temperature

| Junction Temperature (T_J) (°C) | Estimated Lifetime (MTBF) (Year) |
|-------------------------------------|----------------------------------|
| 100 | 40 |
| 125 | 22 |
| 150 | 12 |
| 175 | 7 |

Table 5 summarizes the thermal resistance data related to the package of interest.

Table 5. Thermal Resistance Data

| Symbol | Parameter | Condition | Package | Typ | Unit |
|---------------|--|-----------|---------|-----|----------|
| θ_{JA} | Junction-to-ambient thermal resistance | Still Air | TQFP100 | 40 | °C/ W |
| θ_{JC} | Junction-to-case thermal resistance | | TQFP100 | 6.4 | |

Reliability Data

The number of gates and the device die size are provided for the user to calculate reliability data with another standard and/or in another environmental model.

Table 6. Reliability Data

| Parameter | Data | Unit |
|------------------------|------|-----------------|
| Number of Logic Gates | 272 | K gates |
| Number of Memory Gates | 400 | K gates |
| Device Die Size | 17.6 | mm ² |

Junction Temperature

The average chip-junction temperature T_J in °C can be obtained from the following:

1. $T_J = T_A + (P_D \times \theta_{JA})$
2. $T_J = T_A + (P_D \times (\theta_{HEATSINK} + \theta_{JC}))$

Where:

- θ_{JA} = package thermal resistance, Junction-to-ambient (°C/W), provided in Table 5 on page 4.
- θ_{JC} = package thermal resistance, Junction-to-case thermal resistance (°C/W), provided in Table 5 on page 4.
- $\theta_{HEAT\ SINK}$ = cooling device thermal resistance (°C/W), provided in the device datasheet.
- P_D = device power consumption (W) estimated from data provided in the section “Power Consumption” on page 3.
- T_A = ambient temperature (°C).

From the first equation, the user can derive the estimated lifetime of the chip and thereby decide if a cooling device is necessary or not. If a cooling device is to be fitted on the chip, the second equation should be used to compute the resulting average chip-junction temperature T_J in °C.

Conditions

Timing Results

The delays are given as typical values in the following conditions:

- $V_{DD} = 3.3V$
- Ambient Temperature = $25^{\circ}C$
- Load Capacitance = 0 pF
- The output level change detection is $0.5 \times V_{DD}$
- The input level is $0.3 \times V_{DD}$ for a low-level detection and is $0.7 \times V_{DD}$ for a high level detection.

The minimum and maximum values given in the AC characteristics tables of this datasheet take into account the process variation and the design.

In order to obtain the timing for other conditions, the following equation should be used:

$$t = \delta_{T^{\circ}} \times \delta_{VDD} \times (t_{DATASHEET} + \sum C_{SIGNAL} \times \delta_{CSIGNAL})$$

Where:

- $\delta_{T^{\circ}}$ is the derating factor in temperature given in Figure 1.
- δ_{VDD} is the derating factor for the Power Supply given in Figure 2.
- $t_{DATASHEET}$ is the minimum or maximum timing value given in this datasheet for a load capacitance of 0 pF .
- C_{SIGNAL} is the capacitance load on the considered output pin.⁽¹⁾
- $\delta_{CSIGNAL}$ is the load derating factor depending on the capacitance load on the related output pins given in Min and Max values in this datasheet.

The input delays are given as typical values.

The input delays are given as typical value.

Note: 1. The user must take into account the package capacitance load contribution (C_{IN}) described in Table 1 on page 2.

Temperature Derating Factor

Figure 1. Derating Curve for Different Operating Temperatures

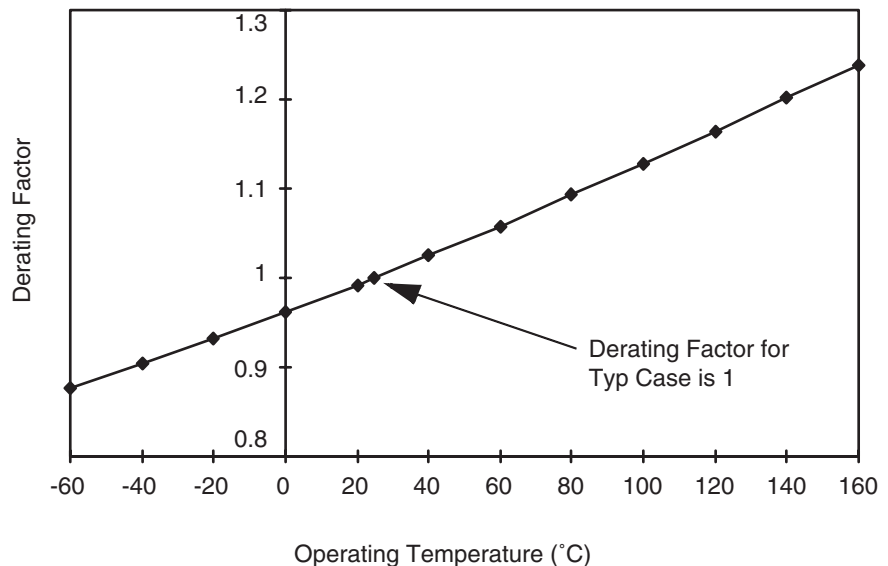

Supply Voltage Derating Factor

Figure 2. Derating Curve for Different Supply Voltages

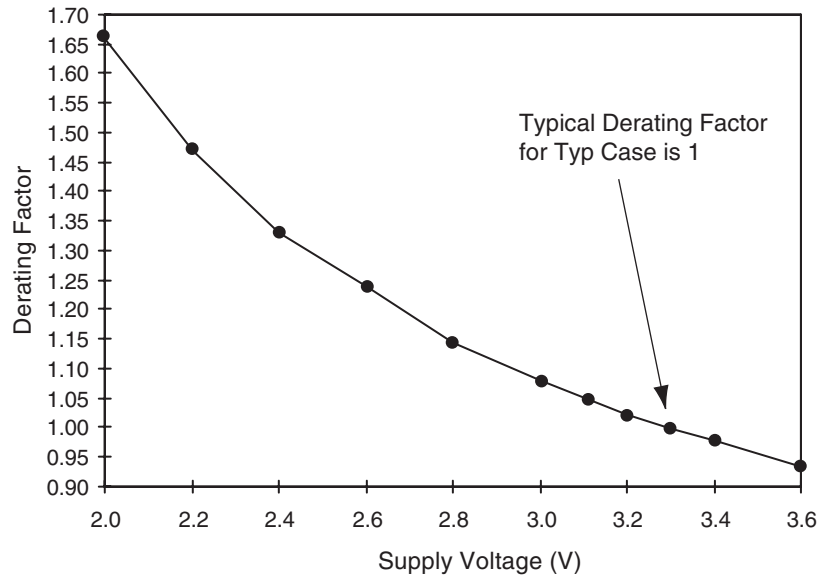

Note: This derating factor is applicable only to timings related to output pins.

Clock Waveforms

Table 7. Master Clock Waveform Parameters

| Symbol | Parameter | Conditions | Min | Max | Units |
|--------------|----------------------|------------|------|------|-------|
| $1/(t_{CP})$ | Oscillator Frequency | | | 47.7 | MHz |
| t_{CP} | Oscillator Period | | 21.0 | | ns |
| t_{CH} | High Half-period | | 9.1 | | ns |
| t_{CL} | Low Half-period | | 9.4 | | ns |

Table 8. Clock Propagation Times

| Symbol | Parameter | Conditions | Min | Max | Units |
|------------|-------------------------------|---------------------------|-------|-------|-------|
| t_{CDLH} | Rising Edge Propagation Time | $C_{MCKO} = 0 \text{ pF}$ | 4.2 | 6.6 | ns |
| | | C_{MCKO} derating | 0.034 | 0.053 | ns/pF |
| t_{CDHL} | Falling Edge Propagation Time | $C_{MCKO} = 0 \text{ pF}$ | 4.5 | 7.1 | ns |
| | | C_{MCKO} derating | 0.042 | 0.066 | ns/pF |

Figure 3. Clock Waveform

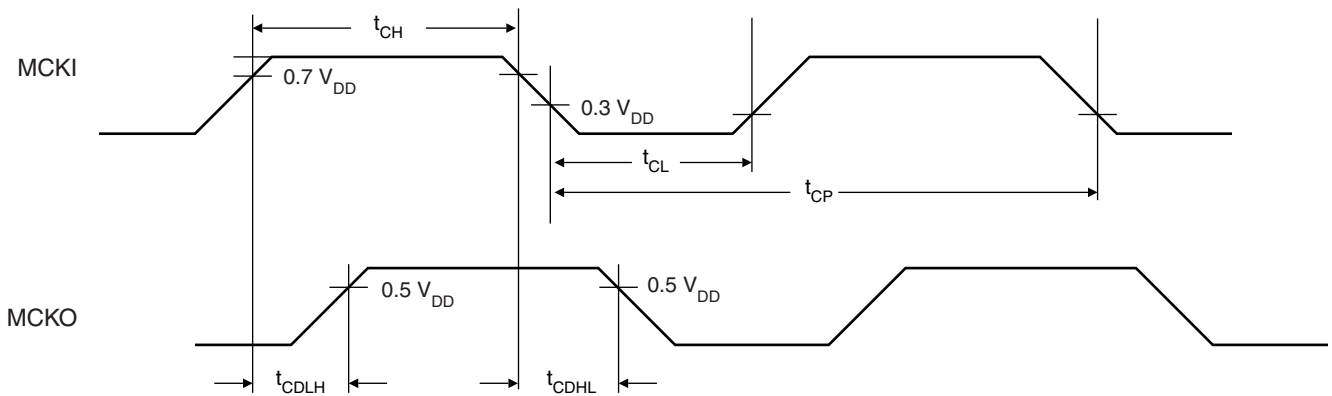
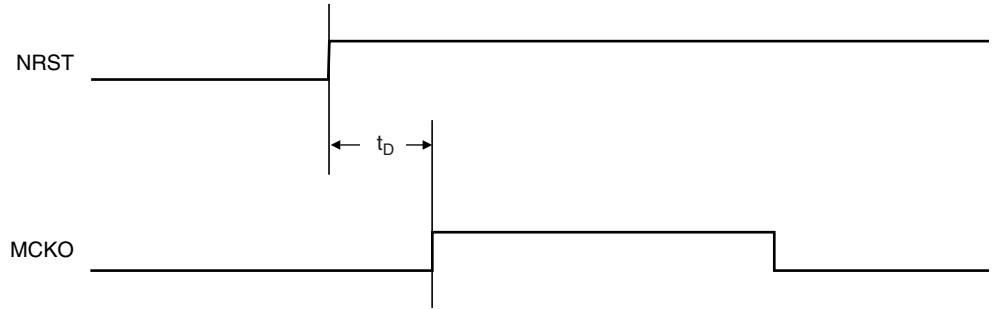

Table 9. NRST to MCKO

| Symbol | Parameter | Min | Max | Units |
|--------|-------------------------------------|---------------|---------------|-------|
| t_D | NRST Rising Edge to MCKO Valid Time | $3(t_{CP}/2)$ | $7(t_{CP}/2)$ | ns |

Figure 4. MCKO Relative to NRST



AC Characteristics

EBI Signals Relative to MCKI

The following tables show timings relative to operating condition limits defined in the section “Timing Results” on page 6. See Figure 5 on page 14.

Table 10. General-purpose EBI Signals

| Symbol | Parameter | Conditions | Min | Max | Units |
|------------------|------------------------------------|-----------------------------|-------|-------|-------|
| EBI ₁ | MCKI Falling to NUB Valid | C _{NUB} = 0 pF | 5.4 | 11.7 | ns |
| | | C _{NUB} derating | 0.034 | 0.066 | ns/pF |
| EBI ₂ | MCKI Falling to NLB/A0 Valid | C _{NLB} = 0 pF | 4.3 | 8.7 | ns |
| | | C _{NLB} derating | 0.038 | 0.062 | ns/pF |
| EBI ₃ | MCKI Falling to A1 - A23 Valid | C _{ADD} = 0 pF | 4.2 | 10.0 | ns |
| | | C _{ADD} = derating | 0.038 | 0.066 | ns/pF |
| EBI ₄ | MCKI Falling to Chip Select Change | C _{NCS} = 0 pF | 4.6 | 10.4 | ns |
| | | C _{NCS} derating | 0.038 | 0.057 | ns/pF |
| EBI ₅ | NWAIT Setup before MCKI Rising | | 0.6 | | ns |
| EBI ₆ | NWAIT Hold after MCKI Rising | | 3.2 | | ns |

Table 11. EBI Write Signals

| Symbol | Parameter | Conditions | Min | Max | Units |
|-------------------|--|----------------------------|--|-------|-------|
| EBI ₇ | MCKI Rising to NWR Active (No Wait States) | C _{NWR} = 0 pF | 4.3 | 7.1 | ns |
| | | C _{NWR} derating | 0.042 | 0.066 | ns/pF |
| EBI ₈ | MCKI Rising to NWR Active (Wait States) | C _{NWR} = 0 pF | 5.0 | 8.2 | ns |
| | | C _{NWR} derating | 0.042 | 0.066 | ns/pF |
| EBI ₉ | MCKI Falling to NWR Inactive (No Wait States) | C _{NWR} = 0 pF | 4.9 | 8.0 | ns |
| | | C _{NWR} derating | 0.034 | 0.053 | ns/pF |
| EBI ₁₀ | MCKI Rising to NWR Inactive (Wait States) | C _{NWR} = 0 pF | 5.0 | 8.2 | ns |
| | | C _{NWR} derating | 0.034 | 0.053 | ns/pF |
| EBI ₁₁ | MCKI Rising to D0 - D15 Out Valid | C _{DATA} = 0 pF | 4.1 | 8.6 | ns |
| | | C _{DATA} derating | 0 | 0.066 | ns/pF |
| EBI ₁₂ | NWR High to NUB Change | C _{NUB} = 0 pF | 3.3 | 7.6 | ns |
| | | C _{NUB} derating | 0.034 | 0.066 | ns/pF |
| EBI ₁₃ | NWR High to NLB/A0 Change | C _{NLB} = 0 pF | 2.8 | 4.6 | ns |
| | | C _{NLB} derating | 0.042 | 0.066 | ns/pF |
| EBI ₁₄ | NWR High to A1 - A23 Change | C _{ADD} = 0 pF | 2.7 | 6.5 | ns |
| | | C _{ADD} derating | 0.042 | 0.066 | ns/pF |
| EBI ₁₅ | NWR High to Chip Select Inactive | C _{NCS} = 0 pF | 3.2 | 6.4 | ns |
| | | C _{NCS} derating | 0.034 | 0.066 | ns/pF |
| EBI ₁₆ | Data Out Valid before NWR High (No Wait States) ⁽¹⁾ | C = 0 pF | t _{CH} - 0.9 | | ns |
| | | C _{DATA} derating | -0.066 | | ns/pF |
| | | C _{NWR} derating | 0.053 | | ns/pF |
| EBI ₁₇ | Data Out Valid before NWR High (Wait States) ⁽¹⁾ | C = 0 pF | n x t _{CP} - 0.8 ⁽²⁾ | | ns |
| | | C _{DATA} derating | -0.066 | | ns/pF |
| | | C _{NWR} derating | 0.053 | | ns/pF |
| EBI ₁₈ | Data Out Valid after NWR High | | 2.1 | | ns |
| EBI ₁₉ | NWR Minimum Pulse Width (No Wait States) ⁽¹⁾ | C _{NWR} = 0 pF | t _{CH} + 0.4 | | ns |
| | | C _{NWR} derating | -0.013 | | ns/pF |
| EBI ₂₀ | NWR Minimum Pulse Width (Wait States) ⁽¹⁾ | C _{NWR} = 0 pF | n x t _{CP} - 0.4 ⁽²⁾ | | ns |
| | | C _{NWR} derating | -0.013 | | ns/pF |

Notes: 1. The derating factor should not be applied to t_{CH} or t_{CP}
 2. n = number of standard wait states inserted.

Table 12. EBI Read Signals

| Symbol | Parameter | Conditions | Min | Max | Units |
|-------------------|---|---------------------------|--|-------|-------|
| EBI ₂₁ | MCKI Falling to NRD Active ⁽¹⁾ | C _{NRD} = 0 pF | 5.0 | 9.0 | ns |
| | | C _{NRD} derating | 0.042 | 0.066 | ns/pF |
| EBI ₂₂ | MCKI Rising to NRD Active ⁽²⁾ | C _{NRD} = 0 pF | 4.1 | 8.6 | ns |
| | | C _{NRD} derating | 0.042 | 0.066 | ns/pF |
| EBI ₂₃ | MCKI Falling to NRD Inactive ⁽¹⁾ | C _{NRD} = 0 pF | 5.2 | 9.4 | ns |
| | | C _{NRD} derating | 0.034 | 0.053 | ns/pF |
| EBI ₂₄ | MCKI Falling to NRD Inactive ⁽²⁾ | C _{NRD} = 0 pF | 4.9 | 7.7 | ns |
| | | C _{NRD} derating | 0.034 | 0.053 | ns/pF |
| EBI ₂₅ | D0 - D15 In Setup before MCKI Falling Edge ⁽⁵⁾ | | -0.3 | | ns |
| EBI ₂₆ | D0 - D15 In Hold after MCKI Falling Edge ⁽⁵⁾ | | 4.0 | | ns |
| EBI ₂₇ | NRD High to NUB Change | C _{NUB} = 0 pF | 4.1 | 8.4 | ns |
| | | C _{NUB} derating | 0.034 | 0.066 | ns/pF |
| EBI ₂₈ | NRD High to NLB/A0 Change | C _{NLB} = 0 pF | 3.3 | 5.2 | ns |
| | | C _{NLB} derating | 0.042 | 0.066 | ns/pF |
| EBI ₂₉ | NRD High to A1 - A23 Change | C _{ADD} = 0 pF | 3.2 | 7.1 | ns |
| | | C _{ADD} derating | 0.042 | 0.066 | ns/pF |
| EBI ₃₀ | NRD High to Chip Select Inactive | C _{NCS} = 0 pF | 3.6 | 6.9 | ns |
| | | C _{NCS} derating | 0.034 | 0.066 | ns/pF |
| EBI ₃₁ | Data Setup before NRD High ⁽⁵⁾ | C _{NRD} = 0 pF | 9.0 | | ns |
| | | C _{NRD} derating | 0.053 | | ns/pF |
| EBI ₃₂ | Data Hold after NRD High ⁽⁵⁾ | C _{NRD} = 0 pF | -2.4 | | ns |
| | | C _{NRD} derating | -0.034 | | ns/pF |
| EBI ₃₃ | NRD Minimum Pulse Width ⁽¹⁾⁽³⁾ | C _{NRD} = 0 pF | (n + 1) t _{CP} - 0.7 ⁽⁴⁾ | | ns |
| | | C _{NRD} derating | -0.013 | | ns/pF |
| EBI ₃₄ | NRD Minimum Pulse Width ⁽²⁾⁽³⁾ | C _{NRD} = 0 pF | n x t _{CP} + (t _{CH} - 0.9) ⁽⁴⁾ | | ns |
| | | C _{NRD} derating | -0.013 | | ns/pF |

- Notes:
1. Early Read Protocol.
 2. Standard Read Protocol.
 3. The derating factor should not be applied to t_{CH} or t_{CP}.
 4. n = number of standard wait states inserted.
 5. Only one of these two timings needs to be met.

Table 13. EBI Read and Write Control Signals. Capacitance Limitation

| Symbol | Parameter | Conditions | Min | Max | Units |
|--------------------|---|--------------------------|-------|-----|-------|
| $T_{CPLNRD}^{(1)}$ | Master Clock Low Due to NRD Capacitance | $C_{NRD} = 0 \text{ pF}$ | 10.8 | | ns |
| | | C_{NRD} derating | 0.053 | | ns/pF |
| $T_{CPLNWR}^{(2)}$ | Master CLock Low Due to NWR Capacitance | $C_{NWR} = 0 \text{ pF}$ | 8.6 | | ns |
| | | C_{NWR} derating | 0.053 | | ns/pF |

- Notes:
- If this condition is not met, the action depends on the read protocol intended for use.
 - Early Read Protocol: Programing an additional t_{DF} (Data Float Output Time) cycle.
 - Standard Read Protocol: Programming an additional t_{DF} Cycle and an additional wait state.
 - Applicable only for chip select programmed with 0 wait state. If this condition is not met, at least one wait state must be programmed.

Figure 5. EBI Signals Relative to MCKI

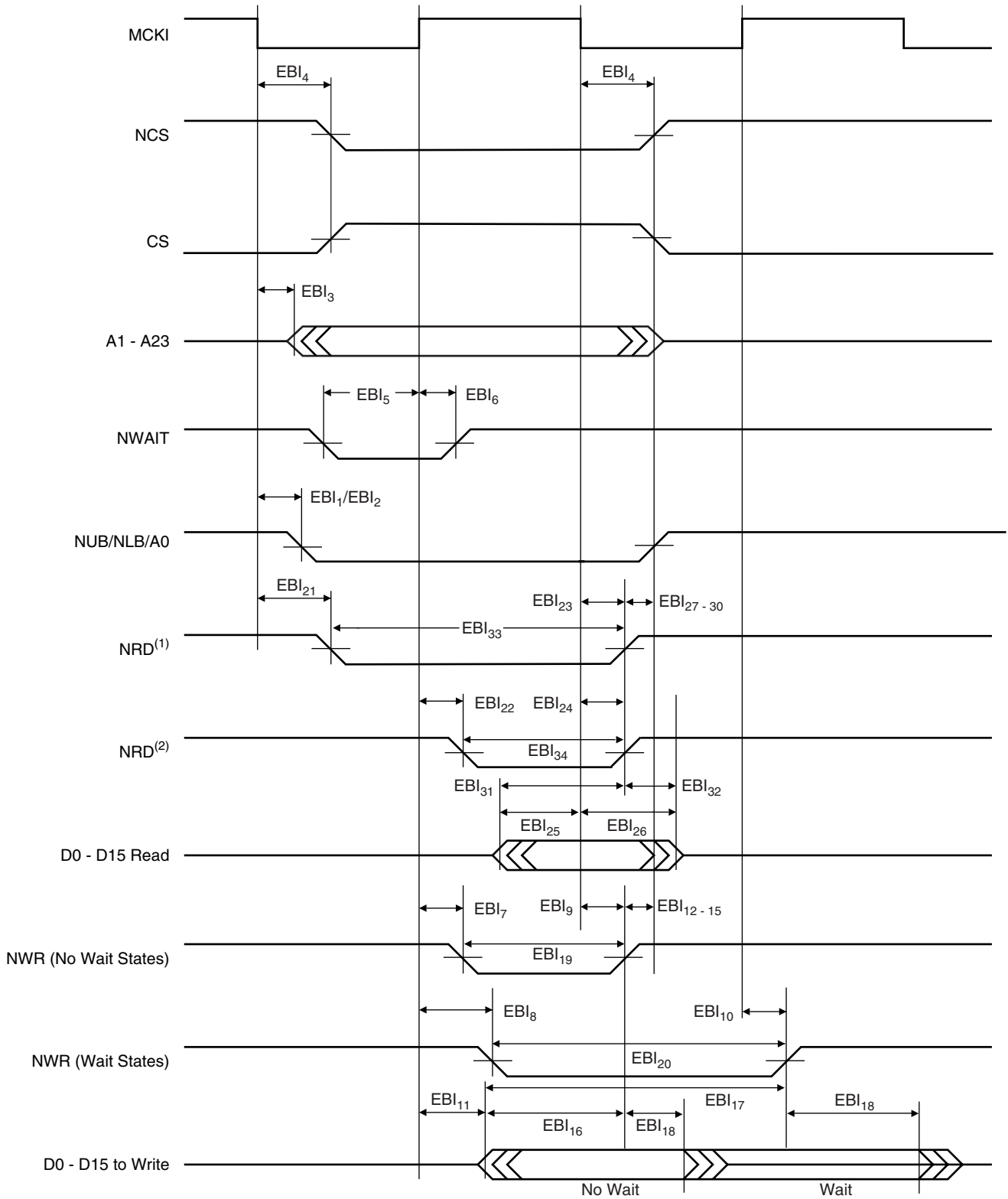

- Notes: 1. Early Read Protocol.
2. Standard Read Protocol.

Peripheral Signals

USART Signals

The inputs have to meet the minimum pulse width and period constraints shown in Table 14 and Table 15, and represented in Figure 6.

Table 14. USART Input Minimum Pulse Width

| Symbol | Parameter | Min Pulse Width | Units |
|-----------------|-----------------------------|-----------------|-------|
| US ₁ | SCK/RXD Minimum Pulse Width | $5(t_{CP}/2)$ | ns |

Table 15. USART Minimum Input Period

| Symbol | Parameter | Min Input Period | Units |
|-----------------|--------------------------|------------------|-------|
| US ₂ | SCK Minimum Input Period | $9(t_{CP}/2)$ | ns |

Figure 6. USART Signals

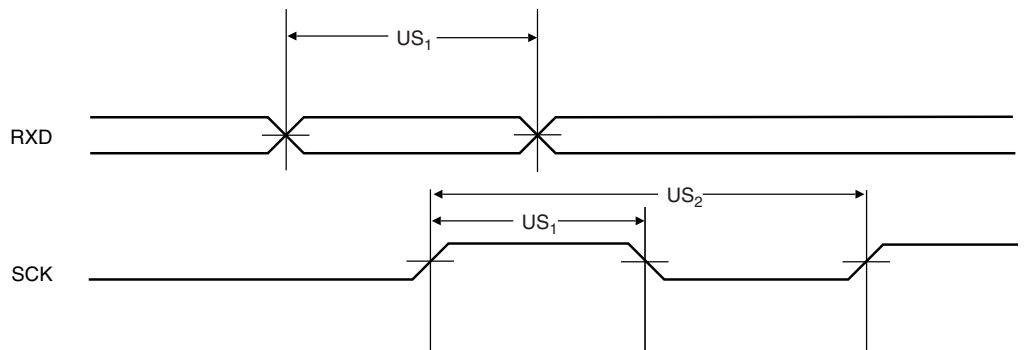

Timer/Counter Signals

Due to internal synchronization of input signals, there is a delay between an input event and a corresponding output event. This delay is $3(t_{CP})$ in Waveform Event Detection mode and $4(t_{CP})$ in Waveform Total-count Detection mode. The inputs have to meet the minimum pulse width and minimum input period shown in Table 16 and Table 17, and as represented in Figure 7.

Table 16. Timer Input Minimum Pulse Width

| Symbol | Parameter | Min Pulse Width | Units |
|-----------------|------------------------------------|-----------------|-------|
| TC ₁ | TCLK/TIOA/TIOB Minimum Pulse Width | $3(t_{CP}/2)$ | ns |

Table 17. Timer Input Minimum Period

| Symbol | Parameter | Min Input Period | Units |
|-----------------|-------------------------------------|------------------|-------|
| TC ₂ | TCLK/TIOA/TIOB Minimum Input Period | $5(t_{CP}/2)$ | ns |

Figure 7. Timer Input

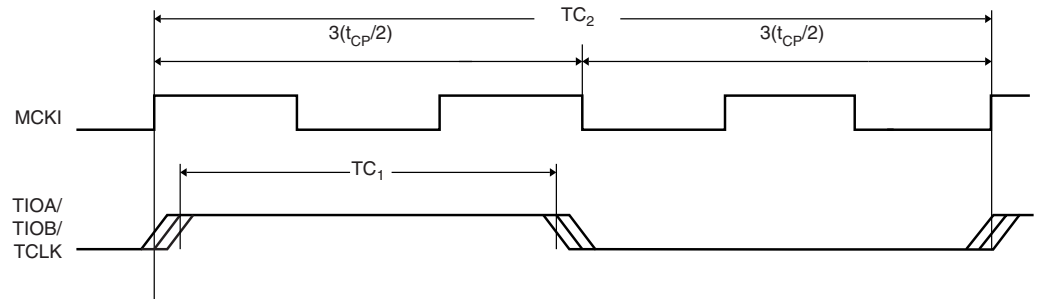

Reset Signals

A minimum pulse width is necessary, as shown in Table 18 and as represented in Figure 8.

Table 18. Reset Minimum Pulse Width

| Symbol | Parameter | Min Pulse-width | Units |
|---------|--------------------------|-----------------|-------|
| RST_1 | NRST Minimum Pulse Width | $10(t_{CP})$ | ns |

Figure 8. Reset Signal



Only the NRST rising edge is synchronized with MCKI. The falling edge is asynchronous.

Advanced Interrupt Controller Signals

Inputs have to meet the minimum pulse width and minimum input period shown in Table 19 and Table 20 and represented in Figure 9.

Table 19. AIC Input Minimum Pulse Width

| Symbol | Parameter | Min Pulse Width | Units |
|------------------|---|-----------------|-------|
| AIC ₁ | FIQ/IRQ0/IRQ1/IRQ2/IRQ3 Minimum Pulse Width | $3(t_{CP}/2)$ | ns |

Table 20. AIC Input Minimum Period

| Symbol | Parameter | Min Input Period | Units |
|------------------|--------------------------|------------------|-------|
| AIC ₂ | AIC Minimum Input Period | $5(t_{CP}/2)$ | ns |

Figure 9. AIC Signals

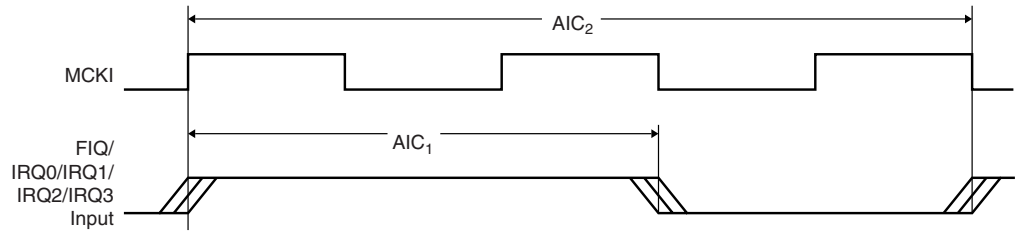

Parallel I/O Signals

The inputs have to meet the minimum pulse width shown in Table 21 and represented in Figure 10.

Table 21. PIO Input Minimum Pulse Width

| Symbol | Parameter | Min Pulse Width | Units |
|------------------|-------------------------------|-----------------|-------|
| PIO ₁ | PIO Input Minimum Pulse Width | $3(t_{CP}/2)$ | ns |

Figure 10. PIO Signal

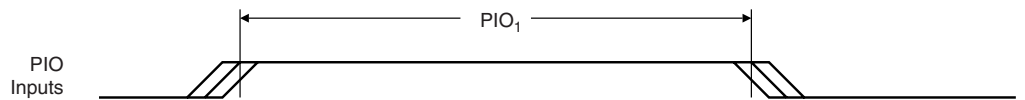

ICE Interface Signals

Table 22. ICE Interface Timing Specifications

| Symbol | Parameter | Conditions | Min | Max | Units |
|------------------|----------------------------------|---------------------------|------|-------|-------|
| ICE ₀ | NTRST Minimum Pulse Width | | 18.8 | | ns |
| ICE ₁ | NTRST High Recovery to TCK High | | 1.2 | | ns |
| ICE ₂ | NTRST High Removal from TCK High | | -0.2 | | ns |
| ICE ₃ | TCK Low Half-period | | 41.7 | | ns |
| ICE ₄ | TCK High Half-period | | 40.9 | | ns |
| ICE ₅ | TCK Period | | 82.5 | | ns |
| ICE ₆ | TDI, TMS Setup before TCK High | | 0.5 | | ns |
| ICE ₇ | TDI, TMS Hold after TCK High | | 0.6 | | ns |
| ICE ₈ | TDO Hold Time | C _{TDO} = 0 pF | 5.2 | | ns |
| | | C _{TDO} derating | 0 | | ns/pF |
| ICE ₉ | TCK Low to TDO Valid | C _{TDO} = 0 pF | | 10.2 | ns |
| | | C _{TDO} derating | | 0.063 | ns/pF |

Figure 11. ICE Interface Signal

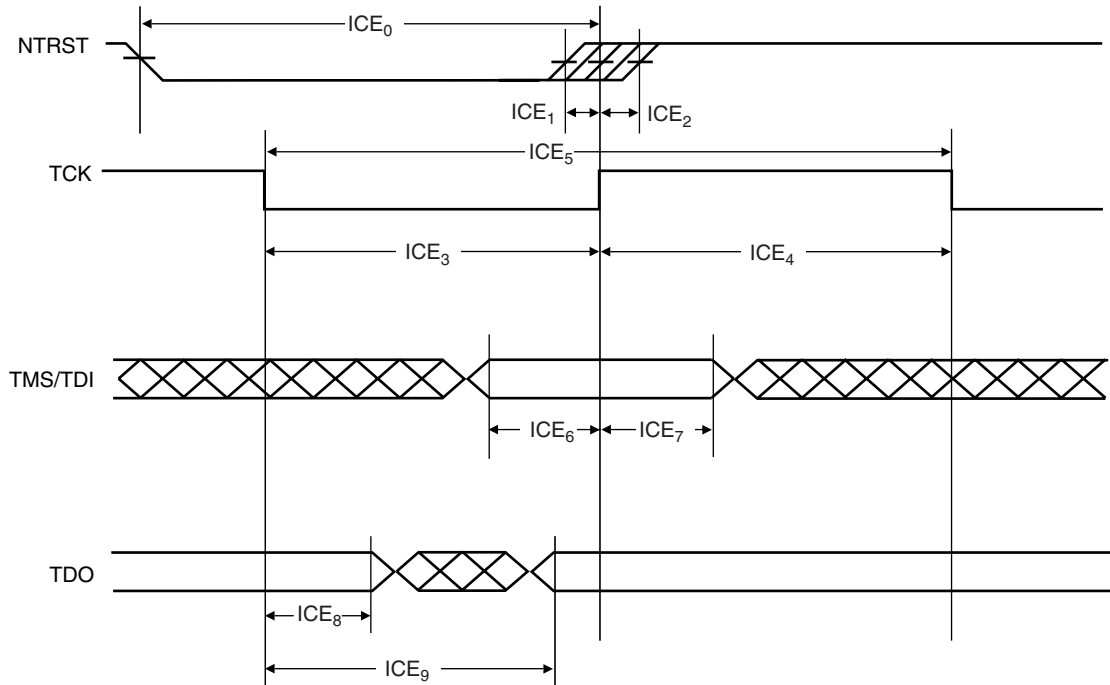

Document Details

Title AT91M40800 Electrical Characteristics

Literature Number Lit# 1393B

Revision History

Version A **Publication Date:** Sep, 2000

Version B **Publication Date:** 10-Dec-2001

Revisions Since Previous Version published on Intranet

Page: 1 “Features” “Fully Static Operation: 0 Hz to 40 MHz Internal Frequency Range at 3.0 V, 85°C” frequency and range modified

Page: 4 “Reliability Data” paragraph modified and new table inserted. “Table 6 Reliability Data”

Page: 6 “Timing Results” Cross reference added to C_{SIGNAL} part of equation.

Page: 8 Table 7. Master Clock Waveform Parameters. Values have been changed for Oscillator Frequency and Oscillator Period. Some master clock parameters deleted.

Page: 10 Table 10. General-purpose EBI Signals. EBI_4 , Conditions are changed.

Page: 13 New table inserted. Table 13. Read and Write Control Signals. Capacitance Limitation. This table adds understanding to EBI Signals Relative to MCK.

Version C **Publication Date:** 19-Nov-2004

Page 8 Changes in Table 7: new figures for t_{CH} and t_{CL} , removed references to t_r and t_f . Updated Figure 3 on page 8.



Atmel Corporation

2325 Orchard Parkway
San Jose, CA 95131, USA
Tel: 1(408) 441-0311
Fax: 1(408) 487-2600

Regional Headquarters

Europe

Atmel Sarl
Route des Arsenaux 41
Case Postale 80
CH-1705 Fribourg
Switzerland
Tel: (41) 26-426-5555
Fax: (41) 26-426-5500

Asia

Room 1219
Chinachem Golden Plaza
77 Mody Road Tsimshatsui
East Kowloon
Hong Kong
Tel: (852) 2721-9778
Fax: (852) 2722-1369

Japan

9F, Tonetsu Shinkawa Bldg.
1-24-8 Shinkawa
Chuo-ku, Tokyo 104-0033
Japan
Tel: (81) 3-3523-3551
Fax: (81) 3-3523-7581

Atmel Operations

Memory

2325 Orchard Parkway
San Jose, CA 95131, USA
Tel: 1(408) 441-0311
Fax: 1(408) 436-4314

Microcontrollers

2325 Orchard Parkway
San Jose, CA 95131, USA
Tel: 1(408) 441-0311
Fax: 1(408) 436-4314

La Chantrerie
BP 70602
44306 Nantes Cedex 3, France
Tel: (33) 2-40-18-18-18
Fax: (33) 2-40-18-19-60

ASIC/ASSP/Smart Cards

Zone Industrielle
13106 Rousset Cedex, France
Tel: (33) 4-42-53-60-00
Fax: (33) 4-42-53-60-01

1150 East Cheyenne Mtn. Blvd.
Colorado Springs, CO 80906, USA
Tel: 1(719) 576-3300
Fax: 1(719) 540-1759

Scottish Enterprise Technology Park
Maxwell Building
East Kilbride G75 0QR, Scotland
Tel: (44) 1355-803-000
Fax: (44) 1355-242-743

RF/Automotive

Theresienstrasse 2
Postfach 3535
74025 Heilbronn, Germany
Tel: (49) 71-31-67-0
Fax: (49) 71-31-67-2340

1150 East Cheyenne Mtn. Blvd.
Colorado Springs, CO 80906, USA
Tel: 1(719) 576-3300
Fax: 1(719) 540-1759

Biometrics/Imaging/Hi-Rel MPU/ High Speed Converters/RF Datacom

Avenue de Rochepleine
BP 123
38521 Saint-Egreve Cedex, France
Tel: (33) 4-76-58-30-00
Fax: (33) 4-76-58-34-80

Literature Requests

www.atmel.com/literature

Disclaimer: The information in this document is provided in connection with Atmel products. No license, express or implied, by estoppel or otherwise, to any intellectual property right is granted by this document or in connection with the sale of Atmel products. **EXCEPT AS SET FORTH IN ATMEL'S TERMS AND CONDITIONS OF SALE LOCATED ON ATMEL'S WEB SITE, ATMEL ASSUMES NO LIABILITY WHATSOEVER AND DISCLAIMS ANY EXPRESS, IMPLIED OR STATUTORY WARRANTY RELATING TO ITS PRODUCTS INCLUDING, BUT NOT LIMITED TO, THE IMPLIED WARRANTY OF MERCHANTABILITY, FITNESS FOR A PARTICULAR PURPOSE, OR NON-INFRINGEMENT. IN NO EVENT SHALL ATMEL BE LIABLE FOR ANY DIRECT, INDIRECT, CONSEQUENTIAL, PUNITIVE, SPECIAL OR INCIDENTAL DAMAGES (INCLUDING, WITHOUT LIMITATION, DAMAGES FOR LOSS OF PROFITS, BUSINESS INTERRUPTION, OR LOSS OF INFORMATION) ARISING OUT OF THE USE OR INABILITY TO USE THIS DOCUMENT, EVEN IF ATMEL HAS BEEN ADVISED OF THE POSSIBILITY OF SUCH DAMAGES.** Atmel makes no representations or warranties with respect to the accuracy or completeness of the contents of this document and reserves the right to make changes to specifications and product descriptions at any time without notice. Atmel does not make any commitment to update the information contained herein. Atmel's products are not intended, authorized, or warranted for use as components in applications intended to support or sustain life.

© Atmel Corporation 2004. All rights reserved. Atmel®, logo and combinations thereof are registered trademarks, and Everywhere You AreSM is the trademark of Atmel Corporation or its subsidiaries. ARM®, Thumb® and ARM7TDMI® are registered trademarks of ARM Ltd. Other terms and product names may be trademarks of others.



Printed on recycled paper.

1393C-ATARM-19-Nov-04

Mouser Electronics

Authorized Distributor

Click to View Pricing, Inventory, Delivery & Lifecycle Information:

[Microchip:](#)

[AT91M40800-33AU](#) [AT91M40800-33AU-999](#)



Компания «ЭлектроПласт» предлагает заключение долгосрочных отношений при поставках импортных электронных компонентов на взаимовыгодных условиях!

Наши преимущества:

- Оперативные поставки широкого спектра электронных компонентов отечественного и импортного производства напрямую от производителей и с крупнейших мировых складов;
- Поставка более 17-ти миллионов наименований электронных компонентов;
- Поставка сложных, дефицитных, либо снятых с производства позиций;
- Оперативные сроки поставки под заказ (от 5 рабочих дней);
- Экспресс доставка в любую точку России;
- Техническая поддержка проекта, помощь в подборе аналогов, поставка прототипов;
- Система менеджмента качества сертифицирована по Международному стандарту ISO 9001;
- Лицензия ФСБ на осуществление работ с использованием сведений, составляющих государственную тайну;
- Поставка специализированных компонентов (Xilinx, Altera, Analog Devices, Intersil, Interpoint, Microsemi, Aeroflex, Peregrine, Syfer, Eurofarad, Texas Instrument, Miteq, Cobham, E2V, MA-COM, Hittite, Mini-Circuits, General Dynamics и др.);

Помимо этого, одним из направлений компании «ЭлектроПласт» является направление «Источники питания». Мы предлагаем Вам помощь Конструкторского отдела:

- Подбор оптимального решения, техническое обоснование при выборе компонента;
- Подбор аналогов;
- Консультации по применению компонента;
- Поставка образцов и прототипов;
- Техническая поддержка проекта;
- Защита от снятия компонента с производства.



Как с нами связаться

Телефон: 8 (812) 309 58 32 (многоканальный)

Факс: 8 (812) 320-02-42

Электронная почта: org@eplast1.ru

Адрес: 198099, г. Санкт-Петербург, ул. Калинина, дом 2, корпус 4, литера А.