

W25R128JV



*spi*flash<sup>®</sup>

**3V 128M-BIT  
SERIAL FLASH MEMORY WITH  
DUAL/QUAD SPI & RPMC**



## Table of Contents

1.	GENERAL DESCRIPTIONS.....	4
2.	FEATURES.....	4
3.	PACKAGE TYPES AND PIN CONFIGURATIONS.....	5
3.1	Pin Configuration SOIC 208-mil .....	5
3.2	Pad Configuration WSON 6x5-mm / 8x6-mm .....	5
3.3	Pin Description SOIC 208-mil, WSON 6x5-mm / 8x6-mm .....	5
4.	PIN DESCRIPTIONS .....	6
4.1	Chip Select (/CS) .....	6
4.2	Serial Data Input, Output and IOs (DI, DO and IO0, IO1, IO2, IO3).....	6
4.3	Serial Clock (CLK) .....	6
4.4	Reset (/RESET).....	6
5.	BLOCK DIAGRAM .....	7
6.	FUNCTIONAL DESCRIPTIONS .....	8
6.1	SPI Operations .....	8
6.1.1	Standard SPI Instructions.....	8
6.1.2	Dual SPI Instructions .....	8
6.1.3	Quad SPI Instructions.....	8
6.1.4	Software Reset & Hardware /RESET pin.....	8
6.2	RPMC Operations.....	9
6.3	Write Protection .....	10
6.3.1	Write Protect Features .....	10
7.	STATUS AND CONFIGURATION REGISTERS .....	12
7.1	Status Registers .....	12
7.1.1	Erase/Write In Progress (BUSY) - <i>Status Only</i> .....	12
7.1.2	Write Enable Latch (WEL) - <i>Status Only</i> .....	12
7.1.3	Block Protect Bits (BP2, BP1, BP0) - <i>Volatile/Non-Volatile Writable</i> .....	12
7.1.4	Top/Bottom Block Protect (TB) - <i>Volatile/Non-Volatile Writable</i> .....	13
7.1.5	Sector/Block Protect Bit (SEC) - <i>Volatile/Non-Volatile Writable</i> .....	13
7.1.6	Complement Protect (CMP) - <i>Volatile/Non-Volatile Writable</i> .....	13
7.1.7	Status Register Protect (SRL) .....	14
7.1.8	Erase/Program Suspend Status (SUS) - <i>Status Only</i> .....	14
7.1.9	Security Register Lock Bits (LB3, LB2, LB1) - <i>Volatile/Non-Volatile OTP Writable</i> .....	15
7.1.10	Quad Enable (QE) - <i>Volatile/Non-Volatile Writable</i> .....	15
7.1.11	Write Protect Selection (WPS) - <i>Volatile/Non-Volatile Writable</i> .....	15
7.1.12	Output Driver Strength (DRV1, DRV0) - <i>Volatile/Non-Volatile Writable</i> .....	16



7.1.13	Reserved Bits - <i>Non Functional</i> .....	16
7.1.14	W25R128JV Status Register Memory Protection (WPS = 0, CMP = 0).....	17
7.1.15	W25R128JV Status Register Memory Protection (WPS = 0, CMP = 1).....	18
7.1.16	W25R128JV Individual Block Memory Protection (WPS = 1).....	19
8.	INSTRUCTIONS.....	20
8.1	Device ID and Instruction Set Tables.....	20
8.1.1	Manufacturer and Device Identification.....	20
8.1.2	Instruction Set Table 1-1 (Standard/Dual/Quad SPI Instructions) <sup>(1)</sup> .....	21
8.1.3	Instruction Set Table 2-1 (RPMC Input Instruction, OP1) <sup>(1)</sup> .....	23
8.1.4	Instruction Set Table 2-2 (RPMC Output Instruction, OP2) <sup>(1)</sup> .....	23
8.2	Instruction Descriptions.....	24
8.2.1	Write Enable (06h).....	24
8.2.2	Write Enable for Volatile Status Register (50h).....	24
8.2.3	Write Disable (04h).....	25
8.2.4	Read Status Register-1 (05h), Status Register-2 (35h) & Status Register-3 (15h).....	25
8.2.5	Write Status Register-1 (01h), Status Register-2 (31h) & Status Register-3 (11h).....	26
8.2.6	Read Data (03h).....	28
8.2.7	Fast Read (0Bh).....	29
8.2.8	Fast Read Dual Output (3Bh).....	30
8.2.9	Fast Read Quad Output (6Bh).....	31
8.2.10	Fast Read Dual I/O (BBh).....	32
8.2.11	Fast Read Quad I/O (EBh).....	33
8.2.12	Set Burst with Wrap (77h).....	34
8.2.13	Page Program (02h).....	35
8.2.14	Quad Input Page Program (32h).....	36
8.2.15	Sector Erase (20h).....	37
8.2.16	32KB Block Erase (52h).....	38
8.2.17	64KB Block Erase (D8h).....	39
8.2.18	Chip Erase (C7h / 60h).....	40
8.2.19	Erase / Program Suspend (75h).....	41
8.2.20	Erase / Program Resume (7Ah).....	42
8.2.21	Power-down (B9h).....	43
8.2.22	Release Power-down / Device ID (ABh).....	44
8.2.23	Read Manufacturer / Device ID (90h).....	45
8.2.24	Read Manufacturer / Device ID Dual I/O (92h).....	46
8.2.25	Read Manufacturer / Device ID Quad I/O (94h).....	47
8.2.26	Read Unique ID Number (4Bh).....	48
8.2.27	Read JEDEC ID (9Fh).....	49
8.2.28	Read SFDP Register (5Ah).....	50
8.2.29	Erase Security Registers (44h).....	51
8.2.30	Program Security Registers (42h).....	52



8.2.31	Read Security Registers (48h) .....	53
8.2.32	Individual Block/Sector Lock (36h) .....	54
8.2.33	Individual Block/Sector Unlock (39h) .....	55
8.2.34	Read Block/Sector Lock (3Dh) .....	56
8.2.35	Global Block/Sector Lock (7Eh) .....	57
8.2.36	Global Block/Sector Unlock (98h) .....	57
8.2.37	Enable Reset (66h) and Reset Device (99h) .....	58
8.2.38	Write Root Key Register (9Bh + 00h) .....	59
8.2.39	Update HMAC Key (9Bh + 01h) .....	60
8.2.40	Increment Monotonic Counter (9Bh + 02h) .....	61
8.2.41	Request Monotonic Counter (9Bh + 03h) .....	62
8.2.42	Reserved RPMC Commands (9Bh + 04h~FFh) .....	62
8.2.43	Read RPMC Status / Data (96h) .....	63
9.	ELECTRICAL CHARACTERISTICS .....	64
9.1	Absolute Maximum Ratings <sup>(1)</sup> .....	64
9.2	Operating Ranges .....	64
9.3	Power-Up Power-Down Timing and Requirements .....	65
9.4	DC Electrical Characteristics <sup>(1)</sup> .....	66
9.5	AC Measurement Conditions .....	67
9.6	AC Electrical Characteristics <sup>(5)</sup> .....	68
9.7	AC Electrical Characteristics (cont' d) .....	69
9.8	Serial Output Timing .....	70
9.9	Serial Input Timing .....	70
10.	PACKAGE SPECIFICATIONS .....	71
10.1	8-Pin SOIC 208-mil (Package Code S) .....	71
10.2	8-Pad WSON 6x5-mm (Package Code P) .....	72
10.3	8-Pad WSON 8x6-mm (Package Code E) .....	73
10.4	Ordering Information .....	74
10.5	Valid Part Numbers and Top Side Marking .....	75
11.	REVISION HISTORY .....	76



## 1. GENERAL DESCRIPTIONS

The W25R128JV (128M-bit) Serial Flash memory provides a storage solution for systems with limited space, pins and power. The W25 series offers flexibility and performance well beyond ordinary Serial Flash devices. They are ideal for code shadowing to RAM, executing code directly from Dual/Quad SPI (XIP) and storing voice, text and data. The device operates on a single 2.7V to 3.6V power supply with current consumption as low as 4mA active and 1µA for power-down. All devices are offered in space-saving packages.

The W25R128JV support the standard Serial Peripheral Interface (SPI), Dual/Quad I/O SPI: Serial Clock, Chip Select, Serial Data I/O0 (DI), I/O1 (DO), I/O2, and I/O3. SPI clock frequencies of up to 133MHz are supported allowing equivalent clock rates of 266MHz (133MHz x 2) for Dual I/O and 532MHz (133MHz x 4) for Quad I/O when using the Fast Read Dual/Quad I/O instructions. These transfer rates can outperform standard Asynchronous 8 and 16-bit Parallel Flash memories.

The device supports JEDEC standard manufacturer and device ID and SFDP Register, a 64-bit Unique Serial Number and three 256-bytes Security Registers.

The W25R series is also equipped with an enhanced security feature known as Replay Protection Monotonic Counter (RPMC). Replay Protection provides a high level secured communication between the flash device and the controller to reduce the system vulnerabilities to hardware attacks.

## 2. FEATURES

- **New Family of SpiFlash Memories**
  - W25R128JV: 128M-bit / 16M-byte
  - Standard SPI: CLK, /CS, DI(IO<sub>0</sub>), DO(IO<sub>1</sub>)
  - Dual SPI: CLK, /CS, IO<sub>0</sub>, IO<sub>1</sub>
  - Quad SPI: CLK, /CS, IO<sub>0</sub>, IO<sub>1</sub>, IO<sub>2</sub>, IO<sub>3</sub>
  - Software Reset
- **Highest Performance Serial Flash**
  - 133MHz Single, Dual/Quad SPI clocks
  - 266/532MHz equivalent Dual/Quad SPI
  - More than 100,000 erase/program cycles
  - More than 20-year data retention
- **Low Power, Wide Temperature Range**
  - Single 2.7 to 3.6V supply
  - 4mA active current, <1µA Power-down (typ.)
  - -40°C to +85°C operating range
- **Flexible Architecture with 4KB sectors**
  - Uniform Sector/Block Erase (4K/32K/64K-Byte)
  - Program 1 to 256 byte per programmable page
  - Erase/Program Suspend & Resume
- **Advanced Security Features**
  - Software and Hardware Write-Protect
  - Power Supply Lock-Down
  - Special OTP protection
  - Top/Bottom, Complement array protection
  - Individual Block/Sector array protection
  - 64-Bit Unique ID for each device
  - Discoverable Parameters (SFDP) Register
  - 3X256-Bytes Security Registers with OTP locks
  - Volatile & Non-volatile Status Register Bits
- **Space Efficient Packaging**
  - 8-pin SOIC 208-mil
  - 8-pad WSON 6x5-mm / 8x6-mm
  - Contact Winbond for other options



### 3. PACKAGE TYPES AND PIN CONFIGURATIONS

#### 3.1 Pin Configuration SOIC 208-mil

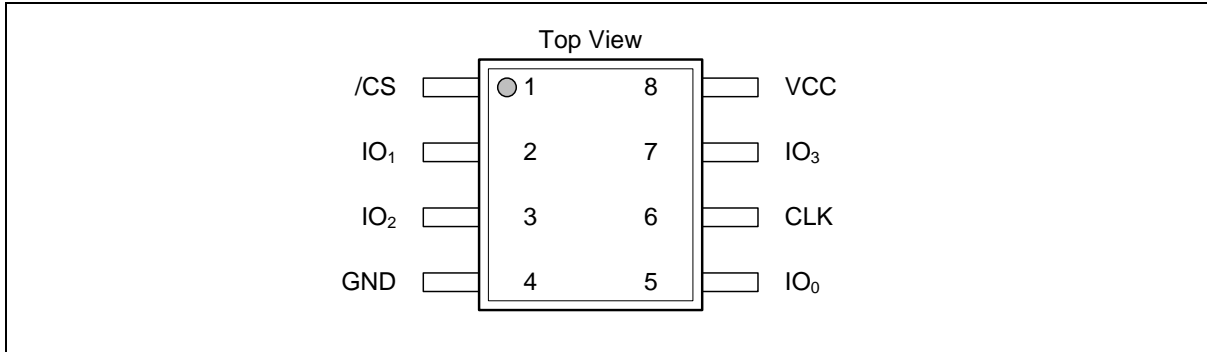

Figure 1a. W25R128JV Pin Assignments, 8-pin SOIC 208-mil (Package Code SS)

#### 3.2 Pad Configuration WSON 6x5-mm / 8x6-mm

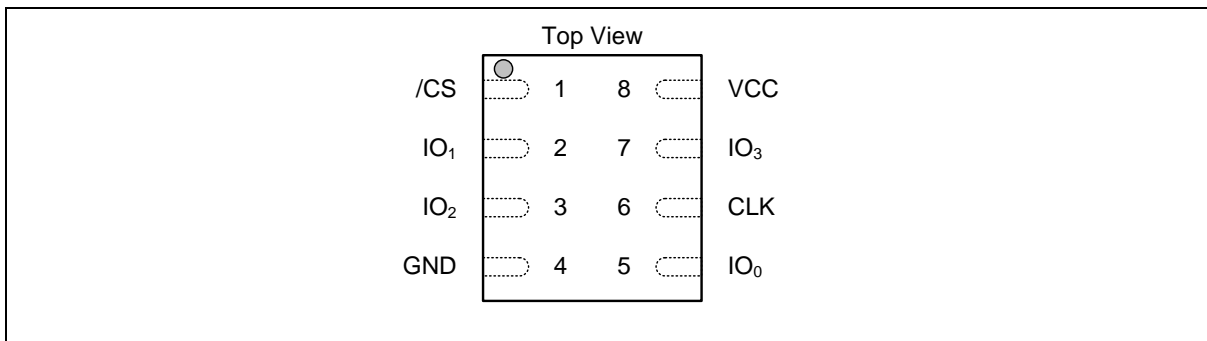

Figure 1b. W25R128JV Pad Assignments, 8-pad WSON 6x5-mm & 8x6-mm (Package Code P & E)

#### 3.3 Pin Description SOIC 208-mil, WSON 6x5-mm / 8x6-mm

PIN NO.	PIN NAME	I/O	FUNCTION
1	/CS	I	Chip Select Input
2	IO1	I/O	Data Input Output 1 <sup>(1)</sup>
3	IO2	I/O	Data Input Output 2 <sup>(2)</sup>
4	GND		Ground
5	IO0	I/O	Data Input Output 0 <sup>(1)</sup>
6	CLK	I	Serial Clock Input
7	IO3	I/O	Data Input Output 3 <sup>(2)</sup>
8	VCC		Power Supply

**Notes:**

- IO0 and IO1 are used for Standard and Dual SPI instructions
- IO0 – IO3 are used for Quad SPI instructions.



## **4. PIN DESCRIPTIONS**

### **4.1 Chip Select (/CS)**

The SPI Chip Select (/CS) pin enables and disables device operation. When /CS is high the device is deselected and the Serial Data Output (DO, or IO0, IO1, IO2, IO3) pins are at high impedance. When deselected, the device's power consumption will be at standby levels unless an internal erase, program or write status register cycle is in progress. When /CS is brought low the device will be selected, power consumption will increase to active levels and instructions can be written to and data read from the device. After power-up, /CS must transition from high to low before a new instruction will be accepted. The /CS input must track the VCC supply level at power-up and power-down (see "Write Protection" and Figure 43a & 43b). If needed a pull-up resistor on the /CS pin can be used to accomplish this.

### **4.2 Serial Data Input, Output and IOs (DI, DO and IO0, IO1, IO2, IO3)**

The W25R128JV supports standard SPI, Dual SPI and Quad SPI operation. Standard SPI instructions use the unidirectional DI (input) pin to serially write instructions, addresses or data to the device on the rising edge of the Serial Clock (CLK) input pin. Standard SPI also uses the unidirectional DO (output) to read data or status from the device on the falling edge of CLK.

Dual and Quad SPI instructions use the bidirectional IO pins to serially write instructions, addresses or data to the device on the rising edge of CLK and read data or status from the device on the falling edge of CLK.

### **4.3 Serial Clock (CLK)**

The SPI Serial Clock Input (CLK) pin provides the timing for serial input and output operations. ("See SPI Operations")

### **4.4 Reset (/RESET)**

The /RESET pin allows the device to be reset by the controller. On the 16-pin SOIC package, a dedicated /RESET pin is provided to reset either SPI or RPMC operations for the entire device.



5. BLOCK DIAGRAM

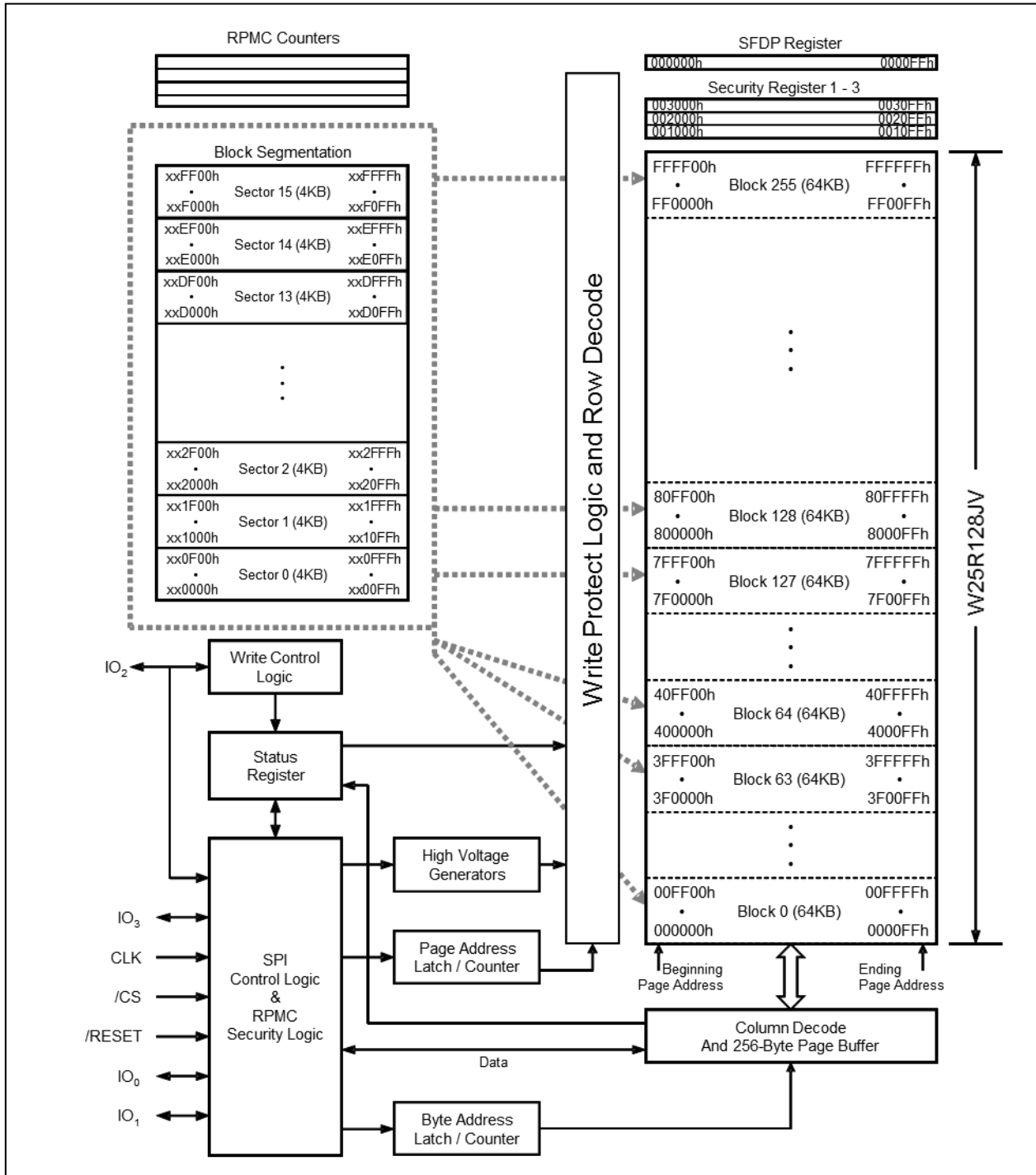

Figure 2. W25R128JV Serial Flash Memory Block Diagram





## 6. FUNCTIONAL DESCRIPTIONS

### 6.1 SPI Operations

#### 6.1.1 Standard SPI Instructions

The W25R128JV is accessed through an SPI compatible bus consisting of four signals: Serial Clock (CLK), Chip Select (/CS), Serial Data Input (DI) and Serial Data Output (DO). Standard SPI instructions use the DI input pin to serially write instructions, addresses or data to the device on the rising edge of CLK. The DO output pin is used to read data or status from the device on the falling edge of CLK.

SPI bus operation Mode 0 (0,0) and 3 (1,1) are supported. The primary difference between Mode 0 and Mode 3 concerns the normal state of the CLK signal when the SPI bus master is in standby and data is not being transferred to the Serial Flash. For Mode 0, the CLK signal is normally low on the falling and rising edges of /CS. For Mode 3, the CLK signal is normally high on the falling and rising edges of /CS.

#### 6.1.2 Dual SPI Instructions

The W25R128JV supports Dual SPI operation when using instructions such as "Fast Read Dual Output (3Bh)" and "Fast Read Dual I/O (BBh)". These instructions allow data to be transferred to or from the device at two to three times the rate of ordinary Serial Flash devices. The Dual SPI Read instructions are ideal for quickly downloading code to RAM upon power-up (code-shadowing) or for executing non-speed-critical code directly from the SPI bus (XIP). When using Dual SPI instructions, the DI and DO pins become bidirectional I/O pins: IO0 and IO1.

#### 6.1.3 Quad SPI Instructions

The W25R128JV supports Quad SPI operation when using instructions such as "Fast Read Quad Output (6Bh)", "Fast Read Quad I/O (EBh)", "Word Read Quad I/O (E7h)" and "Octal Word Read Quad I/O (E3h)". These instructions allow data to be transferred to or from the device four to six times the rate of ordinary Serial Flash. The Quad Read instructions offer a significant improvement in continuous and random access transfer rates allowing fast code-shadowing to RAM or execution directly from the SPI bus (XIP).

#### 6.1.4 Software Reset & Hardware /RESET pin

The W25R128JV can be reset to the initial power-on state by a software Reset sequence. This sequence must include two consecutive commands: Enable Reset (66h) & Reset (99h). If the command sequence is successfully accepted, the device will take approximately 30uS (trST) to reset. No command will be accepted during the reset period.

For the SOIC-16 package, W25R128JV provides a dedicated hardware /RESET pin as illustrated in Figure 1c. Drive the /RESET pin low for a minimum period of ~1us (tRESET\*) will reset the device to its initial power-on state. Hardware /RESET pin has the highest priority among all the input signals. Drive /RESET low for a minimum period of ~1us (tRESET\*) will interrupt any on-going external/internal operations, regardless the status of other SPI signals (/CS, CLK and IOs).

#### Note:

1. While a faster /RESET pulse (as short as a few hundred nanoseconds) will often reset the device, a 1us minimum is recommended to ensure reliable operation.
2. There is an internal pull-up resistor for the dedicated /RESET pin on the SOIC-16 package. If the reset function is not needed, this pin can be left floating in the system.



## **6.2 RPMC Operations**

To prevent hardware vulnerability attack, Replay Protection provides a building block towards providing Confidentiality and Integrity of read/write flash memory data. The W25R128JV is equipped with four 32-bit Monotonic Counters and can be addressed individually by the 8-bit Counter\_Address. These monotonic counters are used by the SPI flash controllers to ensure the physical authenticity of the attached flash devices.

RPMC operation is based on the HMAC-SHA-256 cryptographic algorithm. HMAC-SHA-256 is a type of keyed hash algorithm that is constructed from the SHA-256 hash function and used as a Hash-based Message Authentication Code (HMAC). The HMAC process mixes a secret key with the message data, hashes the result with the hash function, mixes that hash value with the secret key again, and then applies the hash function a second time. The output hash is 256 bits in length.

An HMAC can be used to determine whether a message sent over an insecure channel has been tampered with, provided that the sender and receiver share a secret key. The sender computes the hash value for the original data and sends both the original data and hash value as a single message. The receiver recalculates the hash value on the received message and checks that the computed HMAC matches the transmitted HMAC.

Any change to the data or the hash value results in a mismatch, because knowledge of the secret key is required to change the message and reproduce the correct hash value. Therefore, if the original and computed hash values match, the message is authenticated.

For detailed RPMC information, please refer to Intel's RPMC specification on their web site. The web site link is: [http://downloadcenter.intel.com/Detail\\_Desc.aspx?agr=Y&DwnldID=22646](http://downloadcenter.intel.com/Detail_Desc.aspx?agr=Y&DwnldID=22646)



### 6.3 Write Protection

Applications that use non-volatile memory must take into consideration the possibility of noise and other adverse system conditions that may compromise data integrity. To address this concern, the W25R128JV provides several means to protect the data from inadvertent writes.

#### 6.3.1 Write Protect Features

- Device resets when VCC is below threshold
- Time delay write disable after Power-up
- Write enable/disable instructions and automatic write disable after erase or program
- Software and Hardware (/WP pin) write protection using Status Registers
- Additional Individual Block/Sector Locks for array protection
- Write Protection using Power-down instruction
- Lock Down write protection for Status Register until the next power-up
- One Time Program (OTP) write protection for array and Security Registers using Status Register\*

\* Note: This feature is available upon special order. Please contact Winbond for details.

Upon power-up or at power-down, the W25R128JV will maintain a reset condition while VCC is below the threshold value of  $V_{WI}$ , (See Power-up Timing and Voltage Levels and Figure 43). While reset, all operations are disabled and no instructions are recognized. During power-up and after the VCC voltage exceeds  $V_{WI}$ , all program and erase related instructions are further disabled for a time delay of  $t_{PUW}$ . This includes the Write Enable, Page Program, Sector Erase, Block Erase, Chip Erase and the Write Status Register instructions. Note that the chip select pin (/CS) must track the VCC supply level at power-up until the VCC-min level and  $t_{VSL}$  time delay is reached, and it must also track the VCC supply level at power-down to prevent adverse command sequence. If needed a pull-up resistor on /CS can be used to accomplish this.

After power-up the device is automatically placed in a write-disabled state with the Status Register Write Enable Latch (WEL) set to a 0. A Write Enable instruction must be issued before a Page Program, Sector Erase, Block Erase, Chip Erase or Write Status Register instruction will be accepted. After completing a program, erase or write instruction the Write Enable Latch (WEL) is automatically cleared to a write-disabled state of 0.

Software controlled write protection is facilitated using the Write Status Register instruction and setting the Status Register Protect (SRP, SRL) and Block Protect (CMP, TB, BP[3:0]) bits. These settings allow a portion or the entire memory array to be configured as read only. Used in conjunction with the Write Protect (/WP) pin, changes to the Status Register can be enabled or disabled under hardware control. See Status Register section for further information. Additionally, the Power-down instruction offers an extra level of write protection as all instructions are ignored except for the Release Power-down instruction.

The W25R128JV also provides another Write Protect method using the Individual Block Locks. Each 64KB block (except the top and bottom blocks, total of 254 blocks) and each 4KB sector within the top/bottom blocks (total of 32 sectors) are equipped with an Individual Block Lock bit. When the lock bit is 0, the corresponding sector or block can be erased or programmed; when the lock bit is set to 1, Erase or Program commands issued to the corresponding sector or block will be ignored. When the device is powered on, all Individual Block Lock bits will be 1, so the entire memory array is protected from Erase/Program. An "Individual Block Unlock (39h)" instruction must be issued to unlock any specific sector or block.

## W25R128JV



The WPS bit in Status Register-3 is used to decide which Write Protect scheme should be used. When WPS=0 (factory default), the device will only utilize CMP, SEC, TB, BP[2:0] bits to protect specific areas of the array; when WPS=1, the device will utilize the Individual Block Locks for write protection.



## 7. STATUS AND CONFIGURATION REGISTERS

Three Status and Configuration Registers are provided for W25R128JV. The Read Status Register-1/2/3 instructions can be used to provide status on the availability of the flash memory array, whether the device is write enabled or disabled, the state of write protection, Quad SPI setting, Security Register lock status, Erase/Program Suspend status, output driver strength, power-up. The Write Status Register instruction can be used to configure the device write protection features, Quad SPI setting, Security Register OTP locks, and output driver strength. Write access to the Status Register is controlled by the state of the non-volatile Status Register Protect bits (SRL), the Write Enable instruction, and during Standard/Dual SPI operations

### 7.1 Status Registers

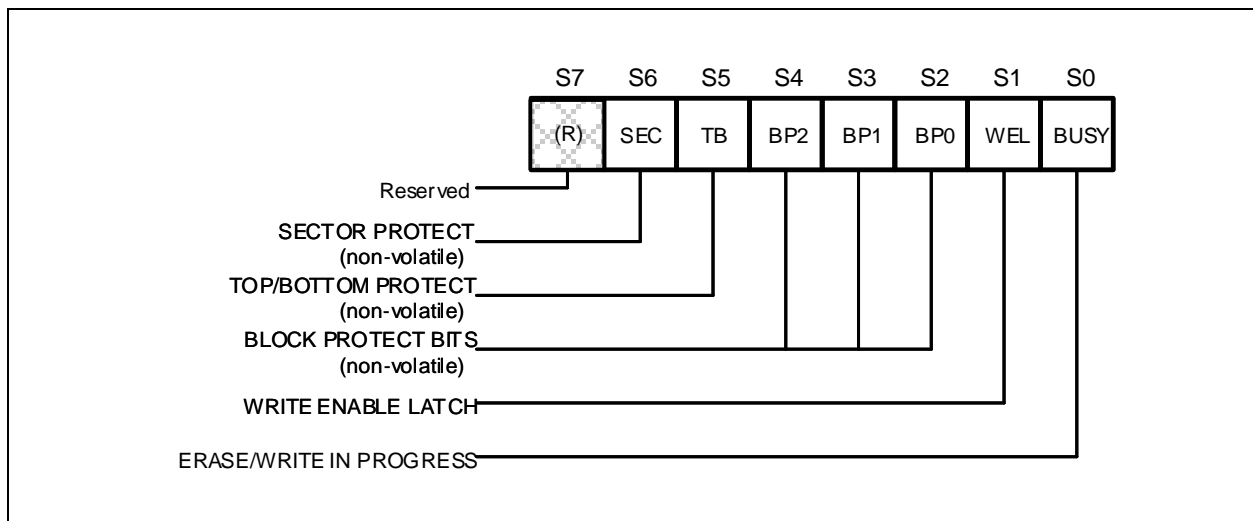

Figure 4a. Status Register-1

#### 7.1.1 Erase/Write In Progress (BUSY) – Status Only

BUSY is a read only bit in the status register (S0) that is set to a 1 state when the device is executing a Page Program, Quad Page Program, Sector Erase, Block Erase, Chip Erase, Write Status Register or Erase/Program Security Register instruction. During this time the device will ignore further instructions except for the Read Status Register and Erase/Program Suspend instruction (see *tw*, *tpp*, *tse*, *tbe*, and *tce* in AC Characteristics). When the program, erase or write status/security register instruction has completed, the BUSY bit will be cleared to a 0 state indicating the device is ready for further instructions.

#### 7.1.2 Write Enable Latch (WEL) – Status Only

Write Enable Latch (WEL) is a read only bit in the status register (S1) that is set to 1 after executing a Write Enable Instruction. The WEL status bit is cleared to 0 when the device is write disabled. A write disable state occurs upon power-up or after any of the following instructions: Write Disable, Page Program, Quad Page Program, Sector Erase, Block Erase, Chip Erase, Write Status Register, Erase Security Register and Program Security Register.

#### 7.1.3 Block Protect Bits (BP2, BP1, BP0) – Volatile/Non-Volatile Writable

The Block Protect Bits (BP2, BP1, BP0) are non-volatile read/write bits in the status register (S4, S3, and S2) that provide Write Protection control and status. Block Protect bits can be set using the Write Status Register Instruction (see *tw* in AC characteristics). All, none or a portion of the memory array can be protected from Program and Erase instructions (see Status Register Memory Protection table). The factory default setting for the Block Protection Bits is 0, none of the array protected.



#### **7.1.4 Top/Bottom Block Protect (TB) – Volatile/Non-Volatile Writable**

The non-volatile Top/Bottom bit (TB) controls if the Block Protect Bits (BP2, BP1, BP0) protect from the Top (TB=0) or the Bottom (TB=1) of the array as shown in the Status Register Memory Protection table. The factory default setting is TB=0. The TB bit can be set with the Write Status Register Instruction depending on the state of the SRL and WEL bits.

#### **7.1.5 Sector/Block Protect Bit (SEC) – Volatile/Non-Volatile Writable**

The non-volatile Sector/Block Protect bit (SEC) controls if the Block Protect Bits (BP2, BP1, BP0) protect either 4KB Sectors (SEC=1) or 64KB Blocks (SEC=0) in the Top (TB=0) or the Bottom (TB=1) of the array as shown in the Status Register Memory Protection table. The default setting is SEC=0.

#### **7.1.6 Complement Protect (CMP) – Volatile/Non-Volatile Writable**

The Complement Protect bit (CMP) is a non-volatile read/write bit in the status register (S14). It is used in conjunction with SEC, TB, BP2, BP1 and BP0 bits to provide more flexibility for the array protection. Once CMP is set to 1, previous array protection set by SEC, TB, BP2, BP1 and BP0 will be reversed. For instance, when CMP=0, a top 64KB block can be protected while the rest of the array is not; when CMP=1, the top 64KB block will become unprotected while the rest of the array become read-only. Please refer to the Status Register Memory Protection table for details. The default setting is CMP=0.



### 7.1.7 Status Register Protect (SRL)

The Status Register Lock bit (SRL) is a volatile/non-volatile read/write bit in the status register (S8). The SRL bit controls the method of write protection to the Status Registers: temporary Power Lock-Down or permanently One Time Program OTP.

SRL	Status Register Lock	Description
0	Non-Lock	Status Registers are unlocked.
1	Power Lock-Down (Temporary/Volatile)	Status Registers are locked and cannot be written to until the next power-down, power-up cycle to reset SRL=0.
	One Time Program <sup>(1)</sup> (Permanently/Non-Volatile)	A special instruction flow can be used to permanently OTP lock the Status Registers.

**Note:** Please contact Winbond for details regarding the special instruction sequence.

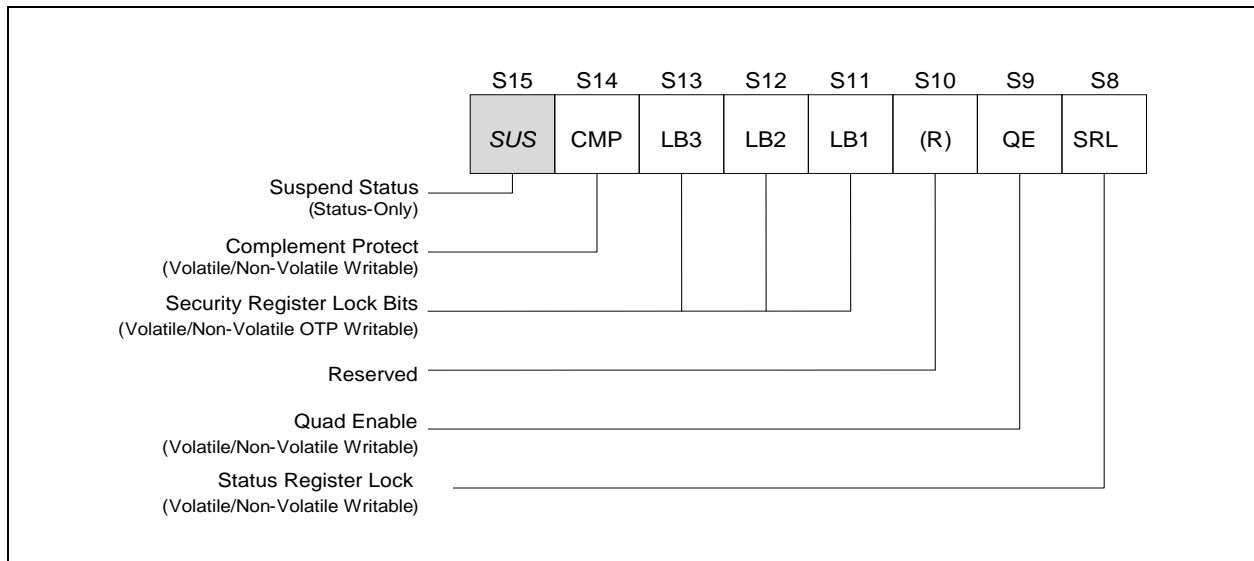

Figure 4b. Status Register-2

### 7.1.8 Erase/Program Suspend Status (SUS) – Status Only

The Suspend Status bit is a read only bit in the status register (S15) that is set to 1 after executing a Erase/Program Suspend (75h) instruction. The SUS status bit is cleared to 0 by Erase/Program Resume (7Ah) instruction as well as a power-down, power-up cycle.



### 7.1.9 Security Register Lock Bits (LB3, LB2, LB1) – Volatile/Non-Volatile OTP Writable

The Security Register Lock Bits (LB3, LB2, LB1) are non-volatile One Time Program (OTP) bits in Status Register (S13, S12, S11) that provide the write protect control and status to the Security Registers. The default state of LB3-1 is 0, Security Registers are unlocked. LB3-1 can be set to 1 individually using the Write Status Register instruction. LB3-1 are One Time Programmable (OTP), once it's set to 1, the corresponding 256-Byte Security Register will become read-only permanently.

### 7.1.10 Quad Enable (QE) – Volatile/Non-Volatile Writable

The Quad Enable (QE) bit is set to 1 by default in the factory, therefore the device supports Standard/Dual SPI as well as Quad SPI after power on. This bit cannot be reset to 0.

Note: QE bit is set to a 0 state, factory default for part numbers with ordering options “IM; please see W25R128JV-DTR data sheet.

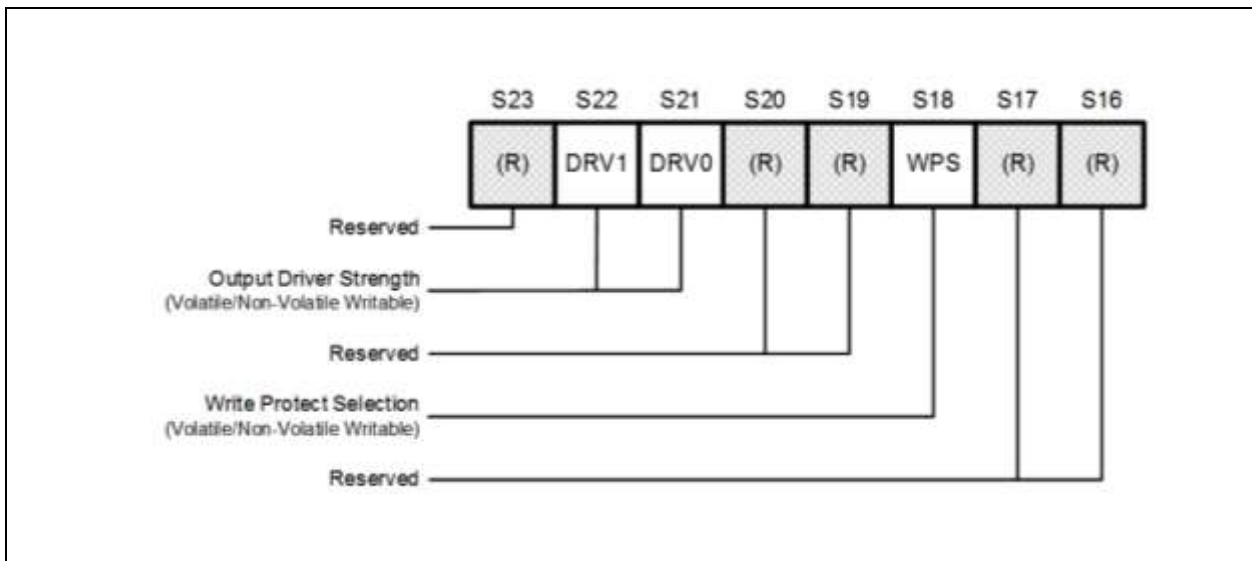

Figure 4c. Status Register-3

### 7.1.11 Write Protect Selection (WPS) – Volatile/Non-Volatile Writable

The WPS bit is used to select which Write Protect scheme should be used. When WPS=0, the device will use the combination of CMP, SEC, TB, BP[2:0] bits to protect a specific area of the memory array. When WPS=1, the device will utilize the Individual Block Locks to protect any individual sector or blocks. The default value for all Individual Block Lock bits is 1 upon device power on or after reset.





### 7.1.12 Output Driver Strength (DRV1, DRV0) – Volatile/Non-Volatile Writable

The DRV1 & DRV0 bits are used to determine the output driver strength for the Read operations.

DRV1, DRV0	Driver Strength
0, 0	100%
0, 1	75%
1, 0	50%(default)
1, 1	25%

### 7.1.13 Reserved Bits – Non Functional

There are a few reserved Status Register bits that may be read out as a “0” or “1”. It is recommended to ignore the values of those bits. During a “Write Status Register” instruction, the Reserved Bits can be written as “0”, but there will not be any effects.



## 7.1.14 W25R128JV Status Register Memory Protection (WPS = 0, CMP = 0)

STATUS REGISTER <sup>(1)</sup>					W25R128JV (128M-BIT) MEMORY PROTECTION <sup>(3)</sup>			
SEC	TB	BP2	BP1	BP0	PROTECTED BLOCK(S)	PROTECTED ADDRESSES	PROTECTED DENSITY	PROTECTED PORTION <sup>(2)</sup>
X	X	0	0	0	NONE	NONE	NONE	NONE
0	0	0	0	1	252 thru 255	FC0000h – FFFFFFFh	256KB	Upper 1/64
0	0	0	1	0	248 thru 255	F80000h – FFFFFFFh	512KB	Upper 1/32
0	0	0	1	1	240 thru 255	F00000h – FFFFFFFh	1MB	Upper 1/16
0	0	1	0	0	224 thru 255	E00000h – FFFFFFFh	2MB	Upper 1/8
0	0	1	0	1	192 thru 255	C00000h – FFFFFFFh	4MB	Upper 1/4
0	0	1	1	0	128 thru 255	800000h – FFFFFFFh	8MB	Upper 1/2
0	1	0	0	1	0 thru 3	000000h – 03FFFFh	256KB	Lower 1/64
0	1	0	1	0	0 thru 7	000000h – 07FFFFh	512KB	Lower 1/32
0	1	0	1	1	0 thru 15	000000h – 0FFFFFFh	1MB	Lower 1/16
0	1	1	0	0	0 thru 31	000000h – 1FFFFFFh	2MB	Lower 1/8
0	1	1	0	1	0 thru 63	000000h – 3FFFFFFh	4MB	Lower 1/4
0	1	1	1	0	0 thru 127	000000h – 7FFFFFFh	8MB	Lower 1/2
X	X	1	1	1	0 thru 255	000000h – FFFFFFFh	16MB	ALL
1	0	0	0	1	255	FFF000h – FFFFFFFh	4KB	U - 1/4096
1	0	0	1	0	255	FFE000h – FFFFFFFh	8KB	U - 1/2048
1	0	0	1	1	255	FFC000h – FFFFFFFh	16KB	U - 1/1024
1	0	1	0	X	255	FF8000h – FFFFFFFh	32KB	U - 1/512
1	1	0	0	1	0	000000h – 000FFFh	4KB	L - 1/4096
1	1	0	1	0	0	000000h – 001FFFh	8KB	L - 1/2048
1	1	0	1	1	0	000000h – 003FFFh	16KB	L - 1/1024
1	1	1	0	X	0	000000h – 007FFFh	32KB	L - 1/512

**Notes:**

1. X = don't care
2. L = Lower; U = Upper
3. If any Erase or Program command specifies a memory region that contains protected data portion, this command will be ignored.



7.1.15 W25R128JV Status Register Memory Protection (WPS = 0, CMP = 1)

STATUS REGISTER <sup>(1)</sup>					W25R128JV (128M-BIT) MEMORY PROTECTION <sup>(3)</sup>			
SEC	TB	BP2	BP1	BP0	PROTECTED BLOCK(S)	PROTECTED ADDRESSES	PROTECTED DENSITY	PROTECTED PORTION <sup>(2)</sup>
X	X	0	0	0	0 thru 255	000000h - FFFFFFFh	16MB	ALL
0	0	0	0	1	0 thru 251	000000h - FBFFFFFFh	16,128KB	Lower 63/64
0	0	0	1	0	0 thru 247	000000h - F7FFFFFFh	15,872KB	Lower 31/32
0	0	0	1	1	0 thru 239	000000h - EFFFFFFh	15MB	Lower 15/16
0	0	1	0	0	0 thru 223	000000h - DFFFFFFh	14MB	Lower 7/8
0	0	1	0	1	0 thru 191	000000h - BFFFFFFh	12MB	Lower 3/4
0	0	1	1	0	0 thru 127	000000h - 7FFFFFFh	8MB	Lower 1/2
0	1	0	0	1	4 thru 255	040000h - FFFFFFFh	16,128KB	Upper 63/64
0	1	0	1	0	8 thru 255	080000h - FFFFFFFh	15,872KB	Upper 31/32
0	1	0	1	1	16 thru 255	100000h - FFFFFFFh	15MB	Upper 15/16
0	1	1	0	0	32 thru 255	200000h - FFFFFFFh	14MB	Upper 7/8
0	1	1	0	1	64 thru 255	400000h - FFFFFFFh	12MB	Upper 3/4
0	1	1	1	0	128 thru 255	800000h - FFFFFFFh	8MB	Upper 1/2
X	X	1	1	1	NONE	NONE	NONE	NONE
1	0	0	0	1	0 thru 255	000000h - FFEFFFFh	16,380KB	L - 4095/4096
1	0	0	1	0	0 thru 255	000000h - FFDFFFFh	16,376KB	L - 2047/2048
1	0	0	1	1	0 thru 255	000000h - FFBFFFFh	16,368KB	L - 1023/1024
1	0	1	0	X	0 thru 255	000000h - FF7FFFFh	16,352KB	L - 511/512
1	1	0	0	1	0 thru 255	001000h - FFFFFFFh	16,380KB	U - 4095/4096
1	1	0	1	0	0 thru 255	002000h - FFFFFFFh	16,376KB	U - 2047/2048
1	1	0	1	1	0 thru 255	004000h - FFFFFFFh	16,368KB	U - 1023/1024
1	1	1	0	X	0 thru 255	008000h - FFFFFFFh	16,352KB	U - 511/512

Notes:

1. X = don't care
2. L = Lower; U = Upper
3. If any Erase or Program command specifies a memory region that contains protected data portion, this command will be ignored.



7.1.16 W25R128JV Individual Block Memory Protection (WPS = 1)

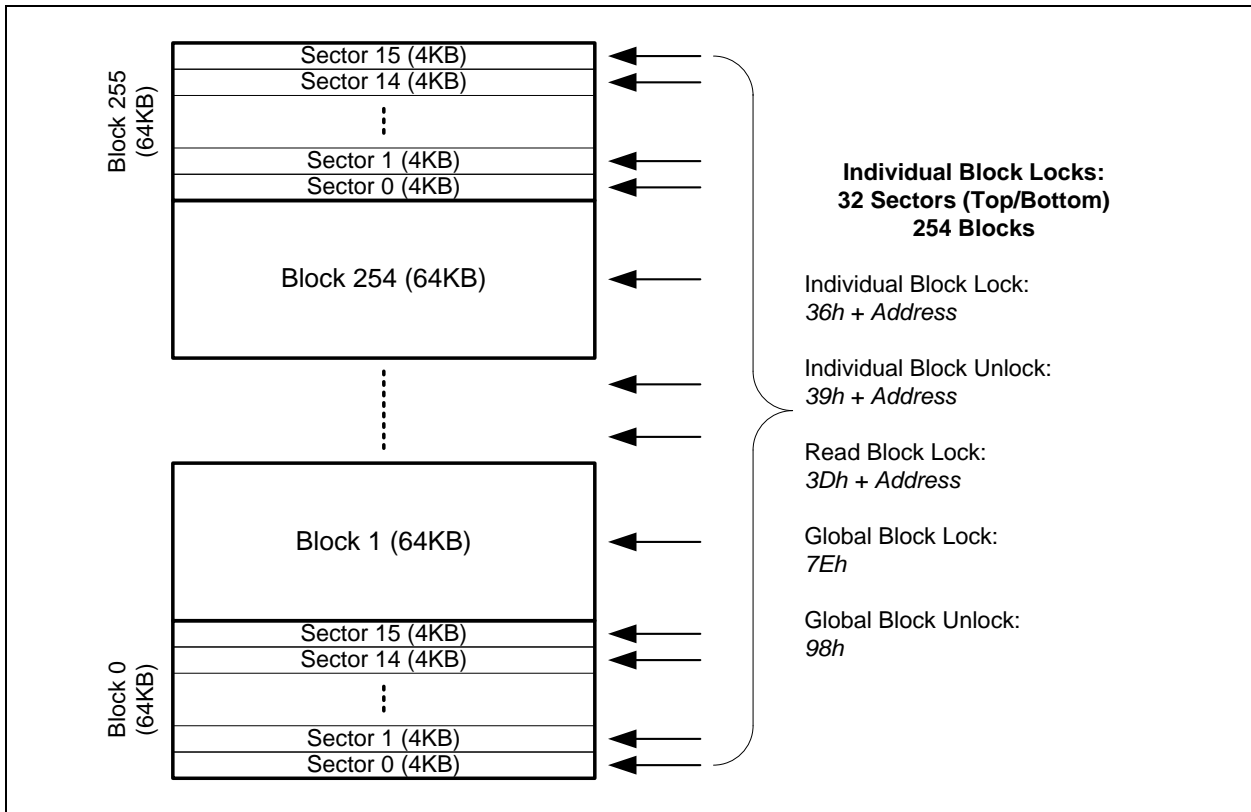

Figure 5. Individual Block/Sector Locks

**Notes:**

1. Individual Block/Sector protection is only valid when WPS=1.
2. All individual block/sector lock bits are set to 1 by default after power up, all memory array is protected.



## 8. INSTRUCTIONS

The Standard/Dual/Quad SPI instruction set of the W25R128JV consists of 47 basic instructions that are fully controlled through the SPI bus (see Instruction Set Table1-1,2). Instructions are initiated with the falling edge of Chip Select (/CS). The first byte of data clocked into the DI input provides the instruction code. Data on the DI input is sampled on the rising edge of clock with most significant bit (MSB) first.

Instructions vary in length from a single byte to several bytes and may be followed by address bytes, data bytes, dummy bytes (don't care), and in some cases, a combination. Instructions are completed with the rising edge of edge /CS. Clock relative timing diagrams for each instruction are included in Figures 6 through 42. All read instructions can be completed after any clocked bit. However, all instructions that Write, Program or Erase must complete on a byte boundary (/CS driven high after a full 8-bits have been clocked) otherwise the instruction will be ignored. This feature further protects the device from inadvertent writes. Additionally, while the memory is being programmed or erased, or when the Status Register is being written, all instructions except for Read Status Register will be ignored until the program or erase cycle has completed.

### 8.1 Device ID and Instruction Set Tables

#### 8.1.1 Manufacturer and Device Identification

<b>MANUFACTURER ID</b>	<b>(MF7 - MF0)</b>	
Winbond Serial Flash	EFh	
<b>Device ID</b>	<b>(ID7 - ID0)</b>	<b>(ID15 - ID0)</b>
<b>Instruction</b>	<b>ABh, 90h, 92h, 94h</b>	<b>9Fh</b>
W25R128JV	17h	4018h

8.1.2 Instruction Set Table 1-1 (Standard/Dual/Quad SPI Instructions)<sup>(1)</sup>

Data Input Output	Byte 1	Byte 2	Byte 3	Byte 4	Byte 5	Byte 6	Byte 7
Number of Clock <sub>(1-1-1)</sub>	8	8	8	8	8	8	8
Write Enable	06h						
Volatile SR Write Enable	50h						
Write Disable	04h						
Release Power-down / ID	ABh	Dummy	Dummy	Dummy	(ID7-ID0) <sup>(2)</sup>		
Manufacturer/Device ID	90h	Dummy	Dummy	00h	(MF7-MF0)	(ID7-ID0)	
JEDEC ID	9Fh	(MF7-MF0)	(ID15-ID8)	(ID7-ID0)			
Read Unique ID	4Bh	Dummy	Dummy	Dummy	Dummy	(UID63-0)	
Read Data	03h	A23-A16	A15-A8	A7-A0	(D7-D0)		
Fast Read	0Bh	A23-A16	A15-A8	A7-A0	Dummy	(D7-D0)	
Page Program	02h	A23-A16	A15-A8	A7-A0	D7-D0	D7-D0 <sup>(3)</sup>	
Sector Erase (4KB)	20h	A23-A16	A15-A8	A7-A0			
Block Erase (32KB)	52h	A23-A16	A15-A8	A7-A0			
Block Erase (64KB)	D8h	A23-A16	A15-A8	A7-A0			
Chip Erase	C7h/60h						
Read Status Register-1	05h	(S7-S0) <sup>(2)</sup>					
Write Status Register-1 <sup>(4)</sup>	01h	(S7-S0) <sup>(4)</sup>					
Read Status Register-2	35h	(S15-S8) <sup>(2)</sup>					
Write Status Register-2	31h	(S15-S8)					
Read Status Register-3	15h	(S23-S16) <sup>(2)</sup>					
Write Status Register-3	11h	(S23-S16)					
Read SFDP Register	5Ah	00h	00h	A7-A0	dummy	(D7-0)	
Erase Security Register <sup>(5)</sup>	44h	A23-A16	A15-A8	A7-A0			
Program Security Register <sup>(5)</sup>	42h	A23-A16	A15-A8	A7-A0	D7-D0	D7-D0 <sup>(3)</sup>	
Read Security Register <sup>(5)</sup>	48h	A23-A16	A15-A8	A7-A0	Dummy	(D7-D0)	
Global Block Lock	7Eh						
Global Block Unlock	98h						
Read Block Lock	3Dh	A23-A16	A15-A8	A7-A0	(L7-L0)		
Individual Block Lock	36h	A23-A16	A15-A8	A7-A0			
Individual Block Unlock	39h	A23-A16	A15-A8	A7-A0			
Erase / Program Suspend	75h						
Erase / Program Resume	7Ah						
Power-down	B9h						
Enable Reset	66h						
Reset Device	99h						



## Notes (For Instruction Set Table 1-1/2):

Data Input Output	Byte 1	Byte 2	Byte 3	Byte 4	Byte 5	Byte 6	Byte 7	Byte 8	Byte 9
Number of Clock <sub>(1-1-2)</sub>	8	8	8	8	4	4	4	4	4
Fast Read Dual Output	3Bh	A23-A16	A15-A8	A7-A0	Dummy	Dummy	(D7-D0) <sup>(7)</sup>		
Number of Clock <sub>(1-2-2)</sub>	8	4	4	4	4	4	4	4	4
Fast Read Dual I/O	BBh	A23-A16 <sup>(6)</sup>	A15-A8 <sup>(6)</sup>	A7-A0 <sup>(6)</sup>	Dummy <sup>(11)</sup>	(D7-D0) <sup>(7)</sup>			
Mftr./Device ID Dual I/O	92h	A23-A16 <sup>(6)</sup>	A15-A8 <sup>(6)</sup>	00 <sup>(6)</sup>	Dummy <sup>(11)</sup>	(MF7-MF0)	(ID7-ID0) <sup>(7)</sup>		
Number of Clock <sub>(1-1-4)</sub>	8	8	8	8	2	2	2	2	2
Quad Input Page Program	32h	A23-A16	A15-A8	A7-A0	(D7-D0) <sup>(9)</sup>	(D7-D0) <sup>(3)</sup>	...		
Fast Read Quad Output	6Bh	A23-A16	A15-A8	A7-A0	Dummy	Dummy	Dummy	Dummy	(D7-D0) <sup>(10)</sup>
Number of Clock <sub>(1-4-4)</sub>	8	2 <sup>(8)</sup>	2 <sup>(8)</sup>	2 <sup>(8)</sup>	2	2	2	2	2
Mftr./Device ID Quad I/O	94h	A23-A16	A15-A8	00	Dummy <sup>(11)</sup>	Dummy	Dummy	(MF7-MF0)	(ID7-ID0)
Fast Read Quad I/O	EBh	A23-A16	A15-A8	A7-A0	Dummy <sup>(11)</sup>	Dummy	Dummy	(D7-D0)	
Set Burst with Wrap	77h	Dummy	Dummy	Dummy	W8-W0				

- Data bytes are shifted with Most Significant Bit first. Byte fields with data in parenthesis “( )” indicate data output from the device on either 1, 2 or 4 IO pins.
- The Status Register contents and Device ID will repeat continuously until /CS terminates the instruction.
- At least one byte of data input is required for Page Program, Quad Page Program and Program Security Registers, up to 256 bytes of data input. If more than 256 bytes of data are sent to the device, the addressing will wrap to the beginning of the page and overwrite previously sent data.
- Write Status Register-1 (01h) can also be used to program Status Register-1&2, see section 8.2.5.
- Security Register Address:  
 Security Register 1: A23-16 = 00h; A15-8 = 10h; A7-0 = byte address  
 Security Register 2: A23-16 = 00h; A15-8 = 20h; A7-0 = byte address  
 Security Register 3: A23-16 = 00h; A15-8 = 30h; A7-0 = byte address
- Dual SPI address input format:  
 IO0 = A22, A20, A18, A16, A14, A12, A10, A8 A6, A4, A2, A0, M6, M4, M2, M0  
 IO1 = A23, A21, A19, A17, A15, A13, A11, A9 A7, A5, A3, A1, M7, M5, M3, M1
- Dual SPI data output format:  
 IO0 = (D6, D4, D2, D0)  
 IO1 = (D7, D5, D3, D1)
- Quad SPI address input format:  
 IO0 = A20, A16, A12, A8, A4, A0, M4, M0  
 IO1 = A21, A17, A13, A9, A5, A1, M5, M1  
 IO2 = A22, A18, A14, A10, A6, A2, M6, M2  
 IO3 = A23, A19, A15, A11, A7, A3, M7, M3
- Quad SPI data input/output format:  
 IO0 = (D4, D0, .....)  
 IO1 = (D5, D1, .....)  
 IO2 = (D6, D2, .....)  
 IO3 = (D7, D3, .....)
- Fast Read Quad I/O data output format:  
 IO0 = (x, x, x, x, D4, D0, D4, D0)  
 IO1 = (x, x, x, x, D5, D1, D5, D1)  
 IO2 = (x, x, x, x, D6, D2, D6, D2)  
 IO3 = (x, x, x, x, D7, D3, D7, D3)

## Set Burst with Wrap input format:

IO0 = x, x, x, x, x, x, W4, x  
 IO1 = x, x, x, x, x, x, W5, x  
 IO2 = x, x, x, x, x, x, W6, x  
 IO3 = x, x, x, x, x, x, x, x



### 8.1.3 Instruction Set Table 2-1 (RPMC Input Instruction, OP1)<sup>(1)</sup>

INSTRUCTION NAME	BYTE 0	BYTE 1 (CmdType)	BYTE 2	BYTE 3 <sup>(2)</sup>		
Write Root Key Register	9Bh	00h	CounterAddr[7:0]	Reserved[7:0]	Byte 4 - 35 RootKey[255:0]	Byte 36 - 63 TruncatedSign[223:0]
Update HMAC Key Register	9Bh	01h	CounterAddr[7:0]	Reserved[7:0]	Byte 4 - 7 KeyData[31:0]	Byte 8 - 39 Signature[255:0]
Increment Monotonic Counter	9Bh	02h	CounterAddr[7:0]	Reserved[7:0]	Byte 4 - 7 CounterData[31:0]	Byte 8 - 39 Signature[255:0]
Request Monotonic Counter	9Bh	03h	CounterAddr[7:0]	Reserved[7:0]	Byte 4 - 15 Tag[95:0]	Byte 16 - 47 Signature[255:0]
Reserved Commands	9Bh	04h ~ FFh	Reserved			

### 8.1.4 Instruction Set Table 2-2 (RPMC Output Instruction, OP2)<sup>(1)</sup>

INSTRUCTION NAME	BYTE 0	BYTE 1	BYTE 2	BYTE 3 - 14	BYTE 15 - 18	BYTE 19 - 50
Read RPMC Status / Data <sup>(3)(4)</sup>	96h	dummy	(RPMC Status[7:0])	(Tag[95:0])	(CounterData[31:0])	(Signature[255:0])

#### Notes (For Instruction Set Table 2-1/2):

1. All RPMC instructions are in Standard SPI format. Each Input/Output Byte requires 8 clocks.
2. The Reserved[7:0] field for RPMC OP1 must be all 0s (00000000'b).
3. The controller may terminate the Read RPMC Status/Data instruction at any time without going through the entire data output sequence.
4. When BUSY=1, from Byte-3 and beyond, the device will output the RPMC\_Status[7:0] value continuously until /CS terminates the instruction. The device will not output Tag, CounterData & Signature fields when BUSY=1. Once BUSY becomes 0, another OP2 command must be issued to read out the correct Tag, CounterData & Signature fields.





## 8.2 Instruction Descriptions

### 8.2.1 Write Enable (06h)

The Write Enable instruction (Figure 6) sets the Write Enable Latch (WEL) bit in the Status Register to a 1. The WEL bit must be set prior to every Page Program, Quad Page Program, Sector Erase, Block Erase, Chip Erase, Write Status Register and Erase/Program Security Registers instruction. The Write Enable instruction is entered by driving /CS low, shifting the instruction code “06h” into the Data Input (DI) pin on the rising edge of CLK, and then driving /CS high.

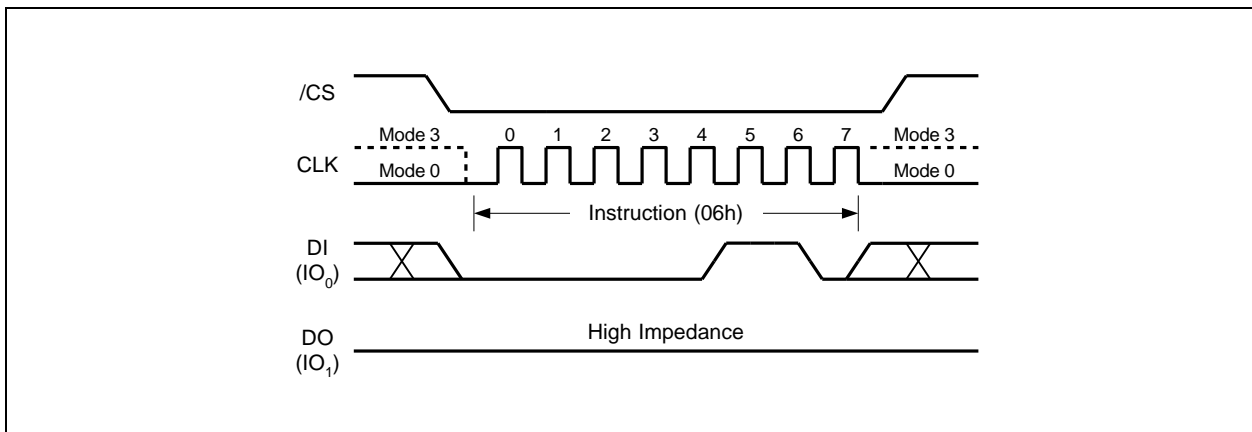

Figure 6. Write Enable Instruction

### 8.2.2 Write Enable for Volatile Status Register (50h)

The non-volatile Status Register bits described in section 7.1 can also be written to as volatile bits. This gives more flexibility to change the system configuration and memory protection schemes quickly without waiting for the typical non-volatile bit write cycles or affecting the endurance of the Status Register non-volatile bits. To write the volatile values into the Status Register bits, the Write Enable for Volatile Status Register (50h) instruction must be issued prior to a Write Status Register (01h) instruction. Write Enable for Volatile Status Register instruction (Figure 7) will not set the Write Enable Latch (WEL) bit, it is only valid for the Write Status Register instruction to change the volatile Status Register bit values.

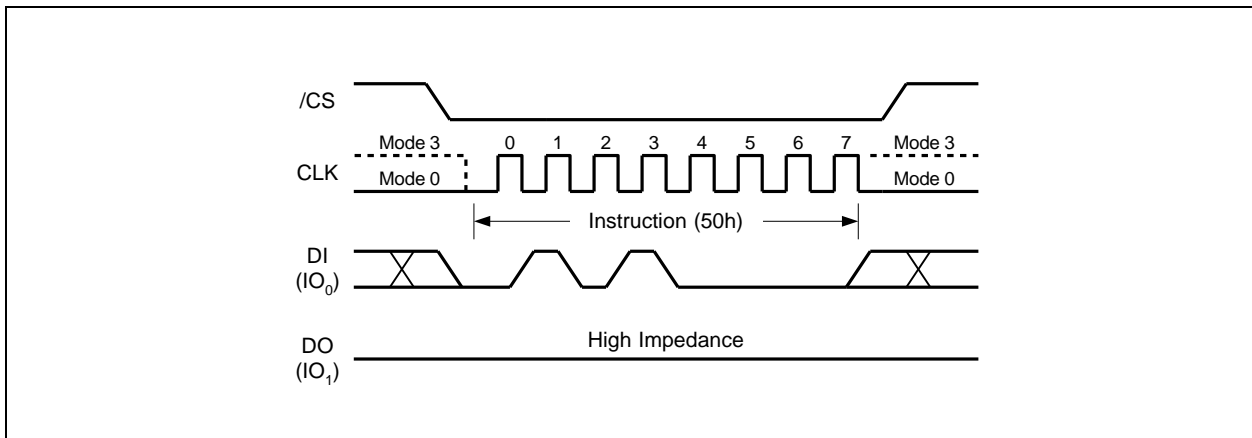

Figure 7. Write Enable for Volatile Status Register Instruction



### 8.2.3 Write Disable (04h)

The Write Disable instruction (Figure 8) resets the Write Enable Latch (WEL) bit in the Status Register to a 0. The Write Disable instruction is entered by driving /CS low, shifting the instruction code “04h” into the DI pin and then driving /CS high. Note that the WEL bit is automatically reset after Power-up and upon completion of the Write Status Register, Erase/Program Security Registers, Page Program, Quad Page Program, Sector Erase, Block Erase, Chip Erase and Reset instructions.

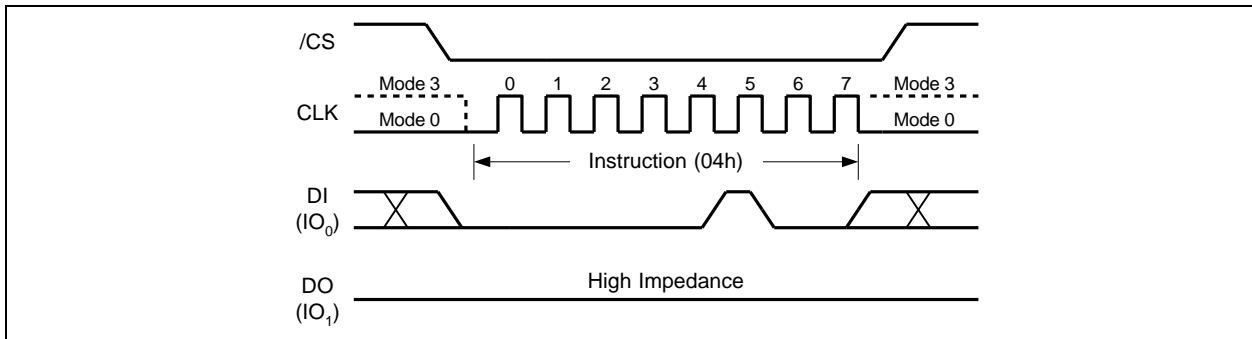

Figure 8. Write Disable Instruction

### 8.2.4 Read Status Register-1 (05h), Status Register-2 (35h) & Status Register-3 (15h)

The Read Status Register instructions allow the 8-bit Status Registers to be read. The instruction is entered by driving /CS low and shifting the instruction code “05h” for Status Register-1, “35h” for Status Register-2 or “15h” for Status Register-3 into the DI pin on the rising edge of CLK. The status register bits are then shifted out on the DO pin at the falling edge of CLK with most significant bit (MSB) first as shown in Figure 9. Refer to section 7.1 for Status Register descriptions.

The Read Status Register instruction may be used at any time, even while a Program, Erase or Write Status Register cycle is in progress. This allows the BUSY status bit to be checked to determine when the cycle is complete and if the device can accept another instruction. The Status Register can be read continuously, as shown in Figure 9. The instruction is completed by driving /CS high.

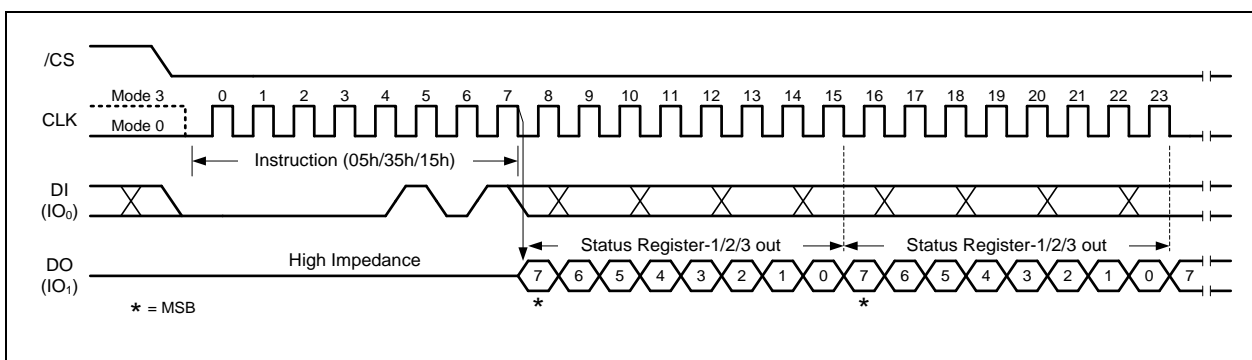

Figure 9. Read Status Register Instruction



**8.2.5 Write Status Register-1 (01h), Status Register-2 (31h) & Status Register-3 (11h)**

The Write Status Register instruction allows the Status Registers to be written. The writable Status Register bits include: SRP0, SEC, TB, BP[2:0] in Status Register-1; CMP, LB[3:1], QE, SRP1 in Status Register-2; HOLD/RST, DRV1, DRV0, WPS & ADP in Status Register-3. All other Status Register bit locations are read-only and will not be affected by the Write Status Register instruction. LB[3:1] are non-volatile OTP bits, once it is set to 1, it cannot be cleared to 0.

To write non-volatile Status Register bits, a standard Write Enable (06h) instruction must previously have been executed for the device to accept the Write Status Register instruction (Status Register bit WEL must equal 1). Once write enabled, the instruction is entered by driving /CS low, sending the instruction code "01h/31h/11h", and then writing the status register data byte as illustrated in Figure 10a & 10b.

To write volatile Status Register bits, a Write Enable for Volatile Status Register (50h) instruction must have been executed prior to the Write Status Register instruction (Status Register bit WEL remains 0). However, SRP1 and LB[3:1] cannot be changed from "1" to "0" because of the OTP protection for these bits. Upon power off or the execution of a Software/Hardware Reset, the volatile Status Register bit values will be lost, and the non-volatile Status Register bit values will be restored.

During non-volatile Status Register write operation (06h combined with 01h/31h/11h), after /CS is driven high, the self-timed Write Status Register cycle will commence for a time duration of  $t_w$  (See AC Characteristics). While the Write Status Register cycle is in progress, the Read Status Register instruction may still be accessed to check the status of the BUSY bit. The BUSY bit is a 1 during the Write Status Register cycle and a 0 when the cycle is finished and ready to accept other instructions again. After the Write Status Register cycle has finished, the Write Enable Latch (WEL) bit in the Status Register will be cleared to 0.

During volatile Status Register write operation (50h combined with 01h/31h/11h), after /CS is driven high, the Status Register bits will be refreshed to the new values within the time period of  $t_{SHSL2}$  (See AC Characteristics). BUSY bit will remain 0 during the Status Register bit refresh period.

Refer to section 7.1 for Status Register descriptions.

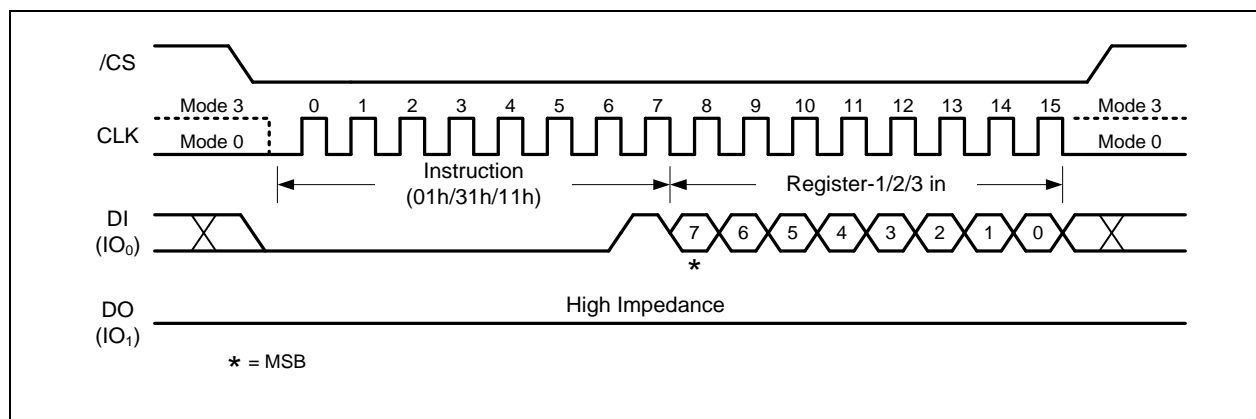

Figure 10a. Write Status Register-1/2/3 Instruction



The W25R128JV is also backward compatible to Winbond's previous generations of serial flash memories, in which the Status Register-1&2 can be written using a single "Write Status Register-1 (01h)" command. To complete the Write Status Register-1&2 instruction, the /CS pin must be driven high after the sixteenth bit of data that is clocked in as shown in Figure 10b. If /CS is driven high after the eighth clock, the Write Status Register-1 (01h) instruction will only program the Status Register-1, the Status Register-2 will not be affected (Previous generations will clear CMP and QE bits).

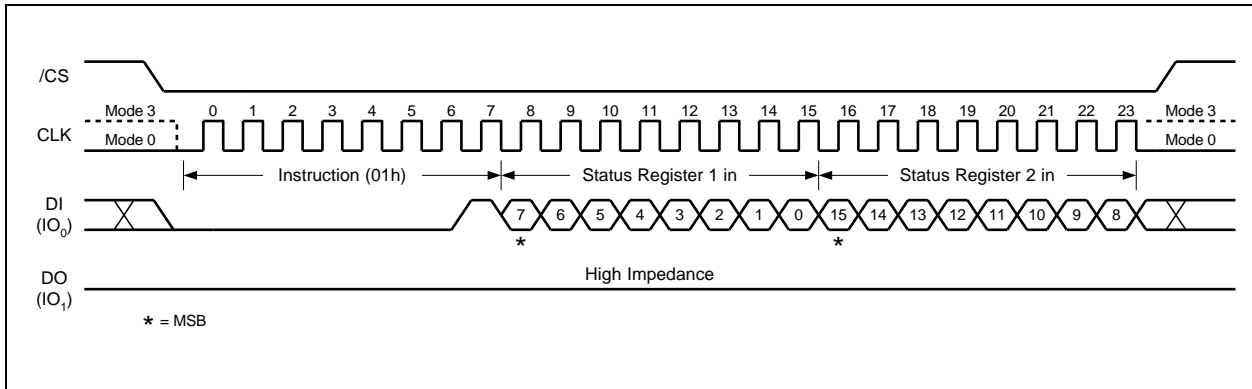

Figure 10b. Write Status Register-1/2 Instruction





### 8.2.7 Fast Read (0Bh)

The Fast Read instruction is similar to the Read Data instruction except that it can operate at the highest possible frequency of FR (see AC Electrical Characteristics). This is accomplished by adding eight “dummy” clocks after the 24-bit address as shown in Figure 12. The dummy clocks allow the devices internal circuits additional time for setting up the initial address. During the dummy clocks the data value on the DO pin is a “don’t care”.

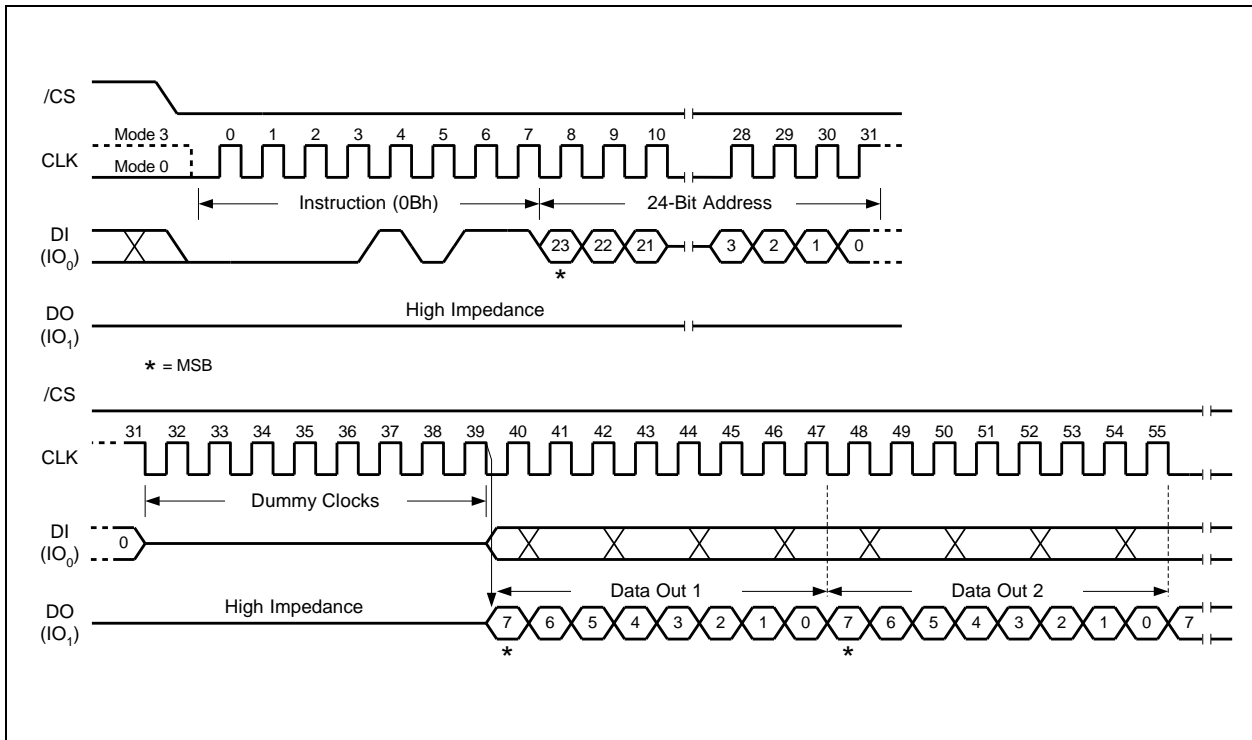

Figure 12. Fast Read Instruction



### 8.2.8 Fast Read Dual Output (3Bh)

The Fast Read Dual Output (3Bh) instruction is similar to the standard Fast Read (0Bh) instruction except that data is output on two pins; IO<sub>0</sub> and IO<sub>1</sub>. This allows data to be transferred at twice the rate of standard SPI devices. The Fast Read Dual Output instruction is ideal for quickly downloading code from Flash to RAM upon power-up or for applications that cache code-segments to RAM for execution.

Similar to the Fast Read instruction, the Fast Read Dual Output instruction can operate at the highest possible frequency of FR (see AC Electrical Characteristics). This is accomplished by adding eight “dummy” clocks after the 24-bit address as shown in Figure 13. The dummy clocks allow the device’s internal circuits additional time for setting up the initial address. The input data during the dummy clocks is “don’t care”. However, the IO<sub>0</sub> pin should be high-impedance prior to the falling edge of the first data out clock. \*

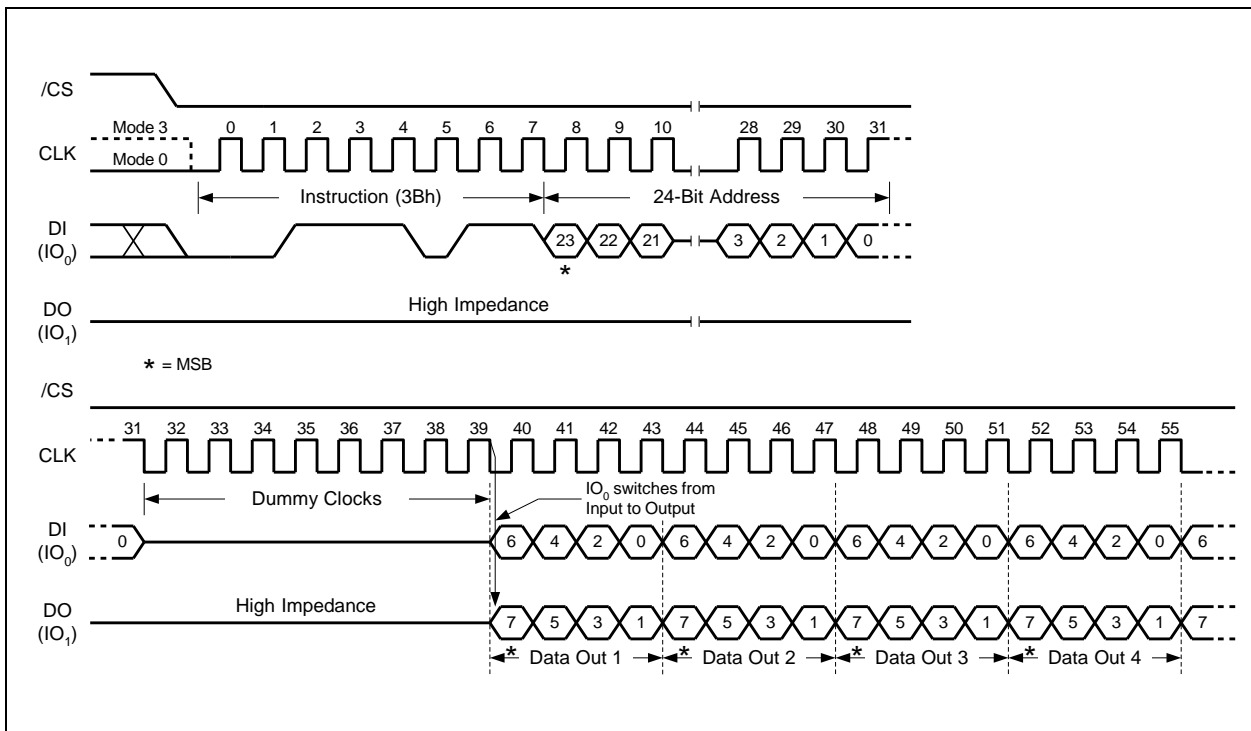

Figure 13. Fast Read Dual Output Instruction



### 8.2.9 Fast Read Quad Output (6Bh)

The Fast Read Quad Output (6Bh) instruction is similar to the Fast Read Dual Output (3Bh) instruction except that data is output on four pins, IO<sub>0</sub>, IO<sub>1</sub>, IO<sub>2</sub>, and IO<sub>3</sub>. The Quad Enable (QE) bit in Status Register-2 must be set to 1 before the device will accept the Fast Read Quad Output Instruction. The Fast Read Quad Output Instruction allows data to be transferred at four times the rate of standard SPI devices.

The Fast Read Quad Output instruction can operate at the highest possible frequency of FR (see AC Electrical Characteristics). This is accomplished by adding eight “dummy” clocks after the 24-bit address as shown in Figure 14. The dummy clocks allow the device’s internal circuits additional time for setting up the initial address. The input data during the dummy clocks is “don’t care”. However, the IO pins should be high-impedance prior to the falling edge of the first data out clock.

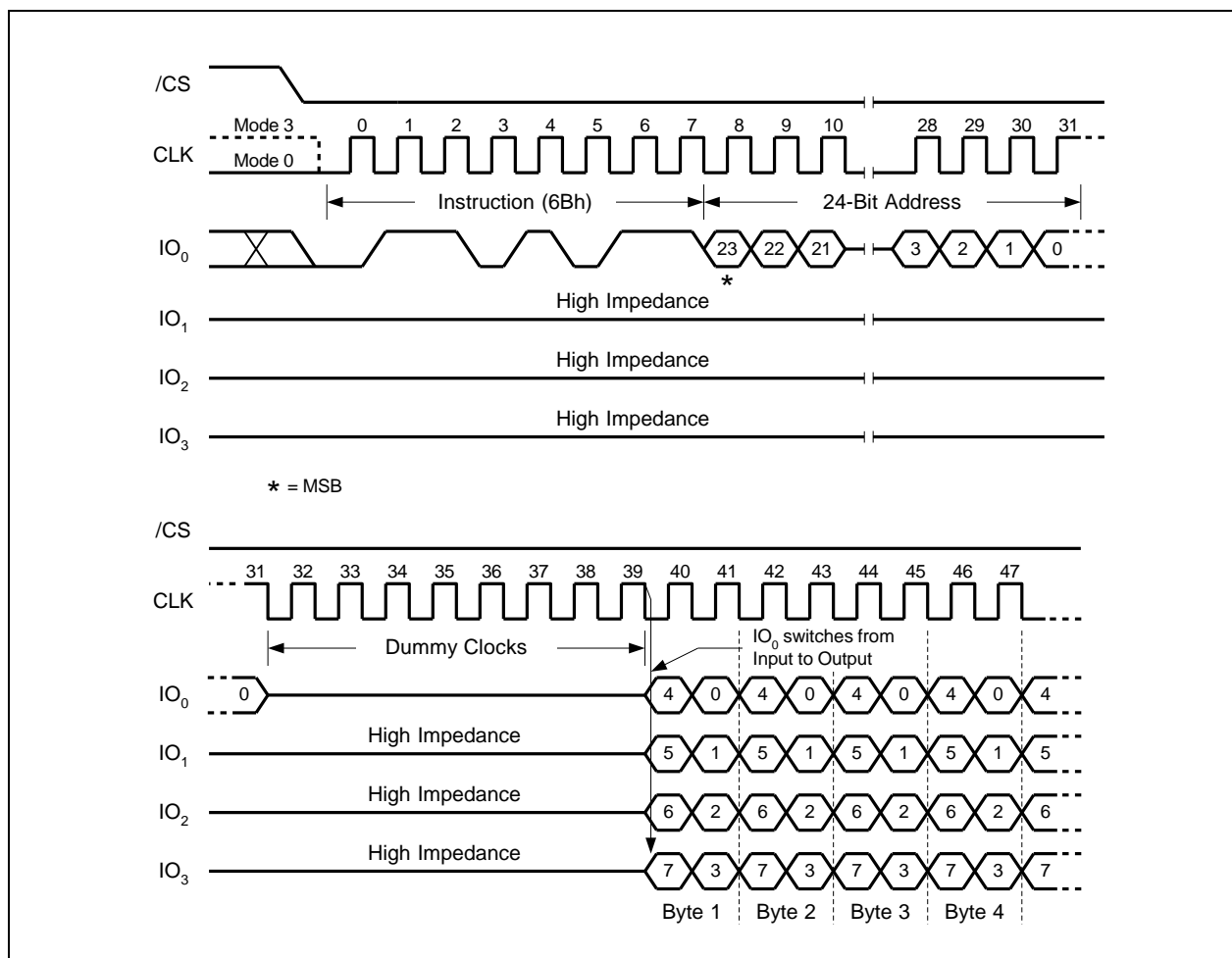

Figure 14. Fast Read Quad Output Instruction





**8.2.10 Fast Read Dual I/O (BBh)**

The Fast Read Dual I/O (BBh) instruction allows for improved random access while maintaining two IO pins, IO<sub>0</sub> and IO<sub>1</sub>. It is similar to the Fast Read Dual Output (3Bh) instruction but with the capability to input the Address bits (A23-0) two bits per clock. This reduced instruction overhead may allow for code execution (XIP) directly from the Dual SPI in some applications.

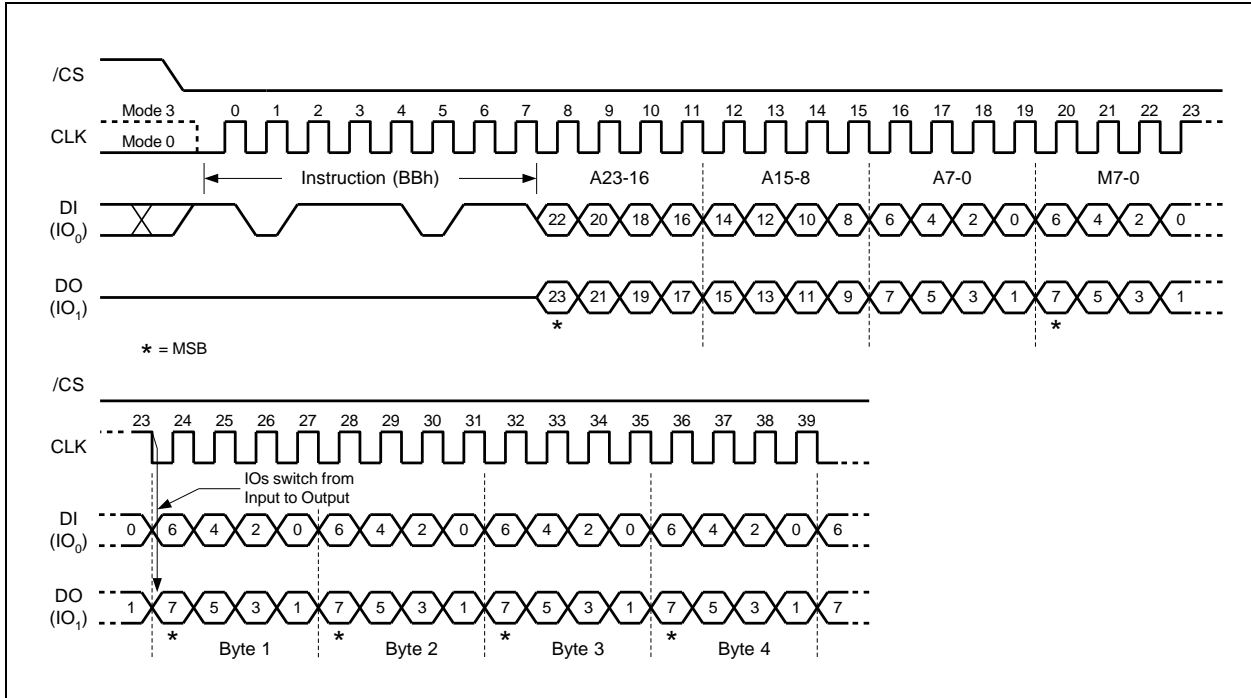

Figure 15. Fast Read Dual I/O Instruction



### 8.2.11 Fast Read Quad I/O (EBh)

The Fast Read Quad I/O (EBh) instruction is similar to the Fast Read Dual I/O (BBh) instruction except that address and data bits are input and output through four pins IO<sub>0</sub>, IO<sub>1</sub>, IO<sub>2</sub> and IO<sub>3</sub> and four Dummy clocks are required in SPI mode prior to the data output. The Quad I/O dramatically reduces instruction overhead allowing faster random access for code execution (XIP) directly from the Quad SPI.

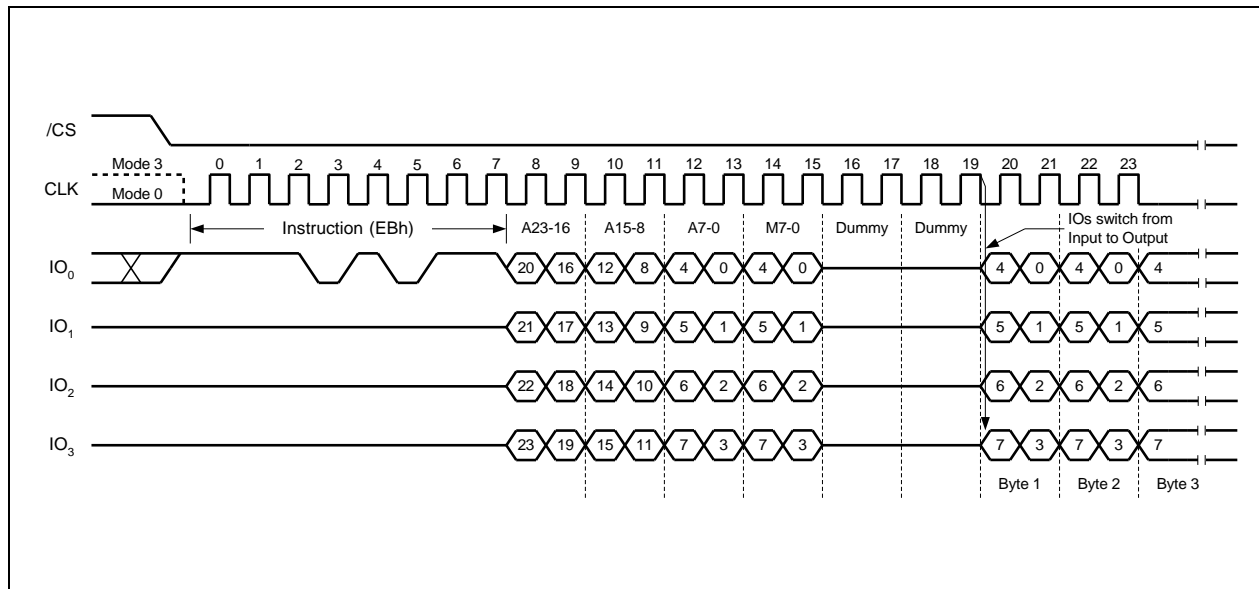

Figure 16. Fast Read Quad I/O Instruction

### Fast Read Quad I/O with “8/16/32/64-Byte Wrap Around”

The Fast Read Quad I/O instruction can also be used to access a specific portion within a page by issuing a “Set Burst with Wrap” (77h) command prior to EBh. The “Set Burst with Wrap” (77h) command can either enable or disable the “Wrap Around” feature for the following EBh commands. When “Wrap Around” is enabled, the data being accessed can be limited to either an 8, 16, 32 or 64-byte section of a 256-byte page. The output data starts at the initial address specified in the instruction, once it reaches the ending boundary of the 8/16/32/64-byte section, the output will wrap around to the beginning boundary automatically until /CS is pulled high to terminate the command.

The Burst with Wrap feature allows applications that use cache to quickly fetch a critical address and then fill the cache afterwards within a fixed length (8/16/32/64-byte) of data without issuing multiple read commands.

The “Set Burst with Wrap” instruction allows three “Wrap Bits”, W6-4 to be set. The W4 bit is used to enable or disable the “Wrap Around” operation while W6-5 are used to specify the length of the wrap around section within a page. Refer to section 8.2.12 for detail descriptions.



**8.2.12 Set Burst with Wrap (77h)**

In Standard SPI mode, the Set Burst with Wrap (77h) instruction is used in conjunction with “Fast Read Quad I/O” instruction to access a fixed length of 8/16/32/64-byte section within a 256-byte page. Certain applications can benefit from this feature and improve the overall system code execution performance.

Similar to a Quad I/O instruction, the Set Burst with Wrap instruction is initiated by driving the /CS pin low and then shifting the instruction code “77h” followed by 24 dummy bits and 8 “Wrap Bits”, W7-0. The instruction sequence is shown in Figure 17. Wrap bit W7 and the lower nibble W3-0 are not used.

W6, W5	W4 = 0		W4 =1 (DEFAULT)	
	Wrap Around	Wrap Length	Wrap Around	Wrap Length
0 0	Yes	8-byte	No	N/A
0 1	Yes	16-byte	No	N/A
1 0	Yes	32-byte	No	N/A
1 1	Yes	64-byte	No	N/A

Once W6-4 is set by a Set Burst with Wrap instruction, all the following “Fast Read Quad I/O” instruction will use the W6-4 setting to access the 8/16/32/64-byte section within any page. To exit the “Wrap Around” function and return to normal read operation, another Set Burst with Wrap instruction should be issued to set W4 = 1. The default value of W4 upon power on or after a software/hardware reset is 1.

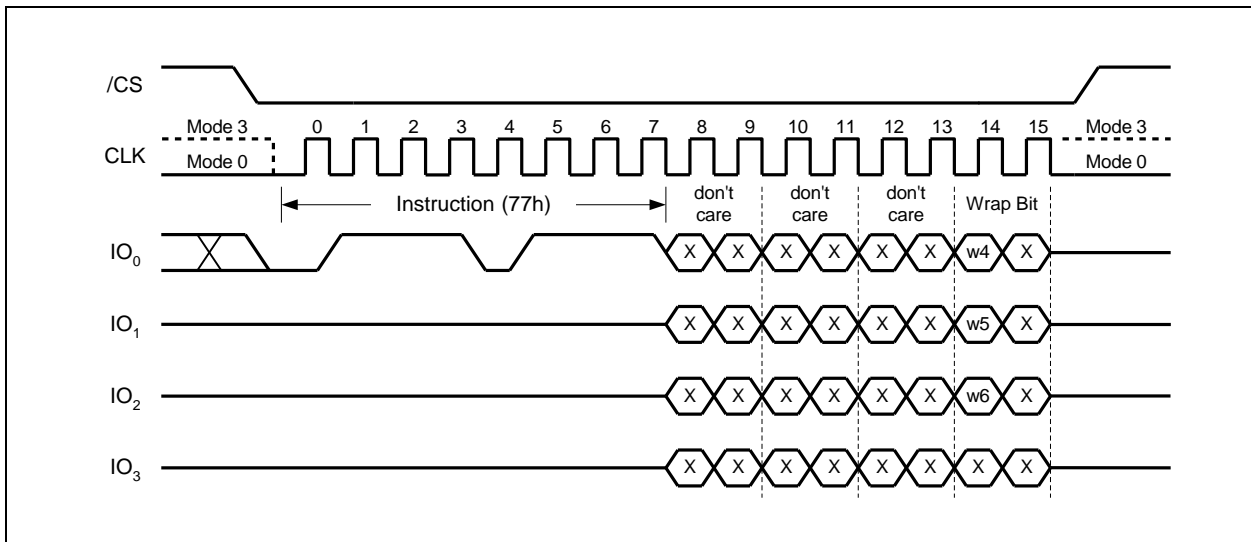

Figure 17. Set Burst with Wrap Instruction



**8.2.13 Page Program (02h)**

The Page Program instruction allows from one byte to 256 bytes (a page) of data to be programmed at previously erased (FFh) memory locations. A Write Enable instruction must be executed before the device will accept the Page Program Instruction (Status Register bit WEL= 1). The instruction is initiated by driving the /CS pin low then shifting the instruction code “02h” followed by a 24-bit address (A23-A0) and at least one data byte, into the DI pin. The /CS pin must be held low for the entire length of the instruction while data is being sent to the device. The Page Program instruction sequence is shown in Figure 18.

If an entire 256 byte page is to be programmed, the last address byte (the 8 least significant address bits) should be set to 0. If the last address byte is not zero, and the number of clocks exceeds the remaining page length, the addressing will wrap to the beginning of the page. In some cases, less than 256 bytes (a partial page) can be programmed without having any effect on other bytes within the same page. One condition to perform a partial page program is that the number of clocks cannot exceed the remaining page length. If more than 256 bytes are sent to the device the addressing will wrap to the beginning of the page and overwrite previously sent data.

As with the write and erase instructions, the /CS pin must be driven high after the eighth bit of the last byte has been latched. If this is not done the Page Program instruction will not be executed. After /CS is driven high, the self-timed Page Program instruction will commence for a time duration of tpp (See AC Characteristics). While the Page Program cycle is in progress, the Read Status Register instruction may still be accessed for checking the status of the BUSY bit. The BUSY bit is a 1 during the Page Program cycle and becomes a 0 when the cycle is finished and the device is ready to accept other instructions again. After the Page Program cycle has finished the Write Enable Latch (WEL) bit in the Status Register is cleared to 0. The Page Program instruction will not be executed if the addressed page is protected by the Block Protect (CMP, SEC, TB, BP2, BP1, and BP0) bits or the Individual Block/Sector Locks.

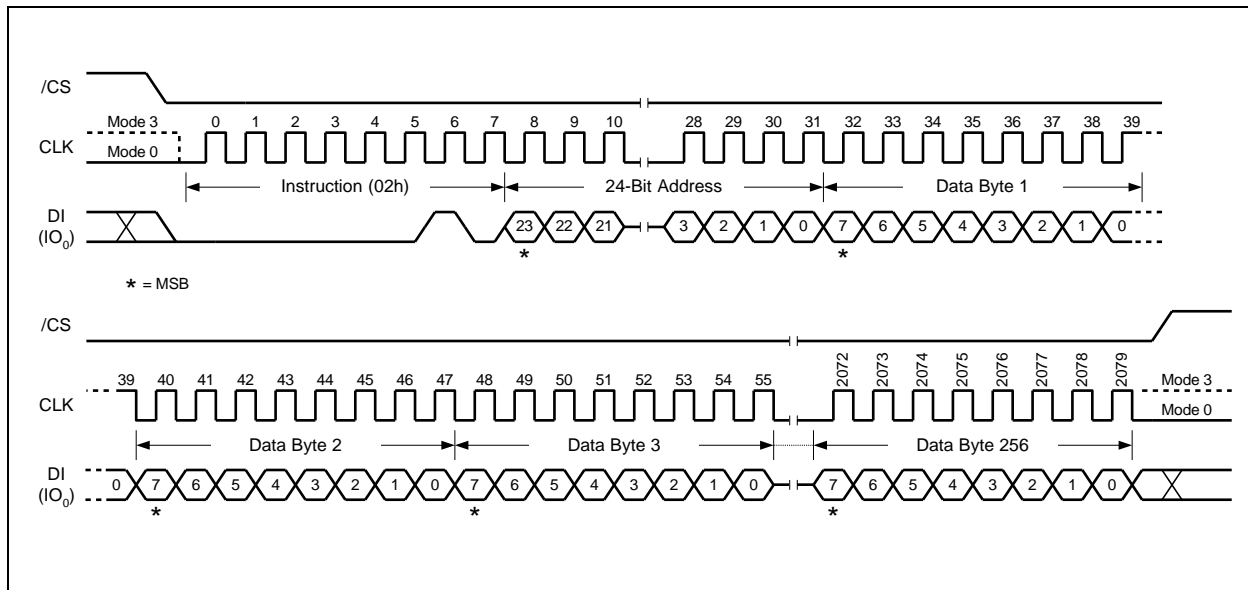

Figure 18. Page Program Instruction



### 8.2.14 Quad Input Page Program (32h)

The Quad Page Program instruction allows up to 256 bytes of data to be programmed at previously erased (FFh) memory locations using four pins: IO<sub>0</sub>, IO<sub>1</sub>, IO<sub>2</sub>, and IO<sub>3</sub>. The Quad Page Program can improve performance for PROM Programmer and applications that have slow clock speeds <5MHz. Systems with faster clock speed will not realize much benefit for the Quad Page Program instruction since the inherent page program time is much greater than the time it take to clock-in the data.

To use Quad Page Program the Quad Enable (QE) bit in Status Register-2 must be set to 1. A Write Enable instruction must be executed before the device will accept the Quad Page Program instruction (Status Register-1, WEL=1). The instruction is initiated by driving the /CS pin low then shifting the instruction code "32h" followed by a 24-bit address (A23-A0) and at least one data byte, into the IO pins. The /CS pin must be held low for the entire length of the instruction while data is being sent to the device. All other functions of Quad Page Program are identical to standard Page Program. The Quad Page Program instruction sequence is shown in Figure 19.

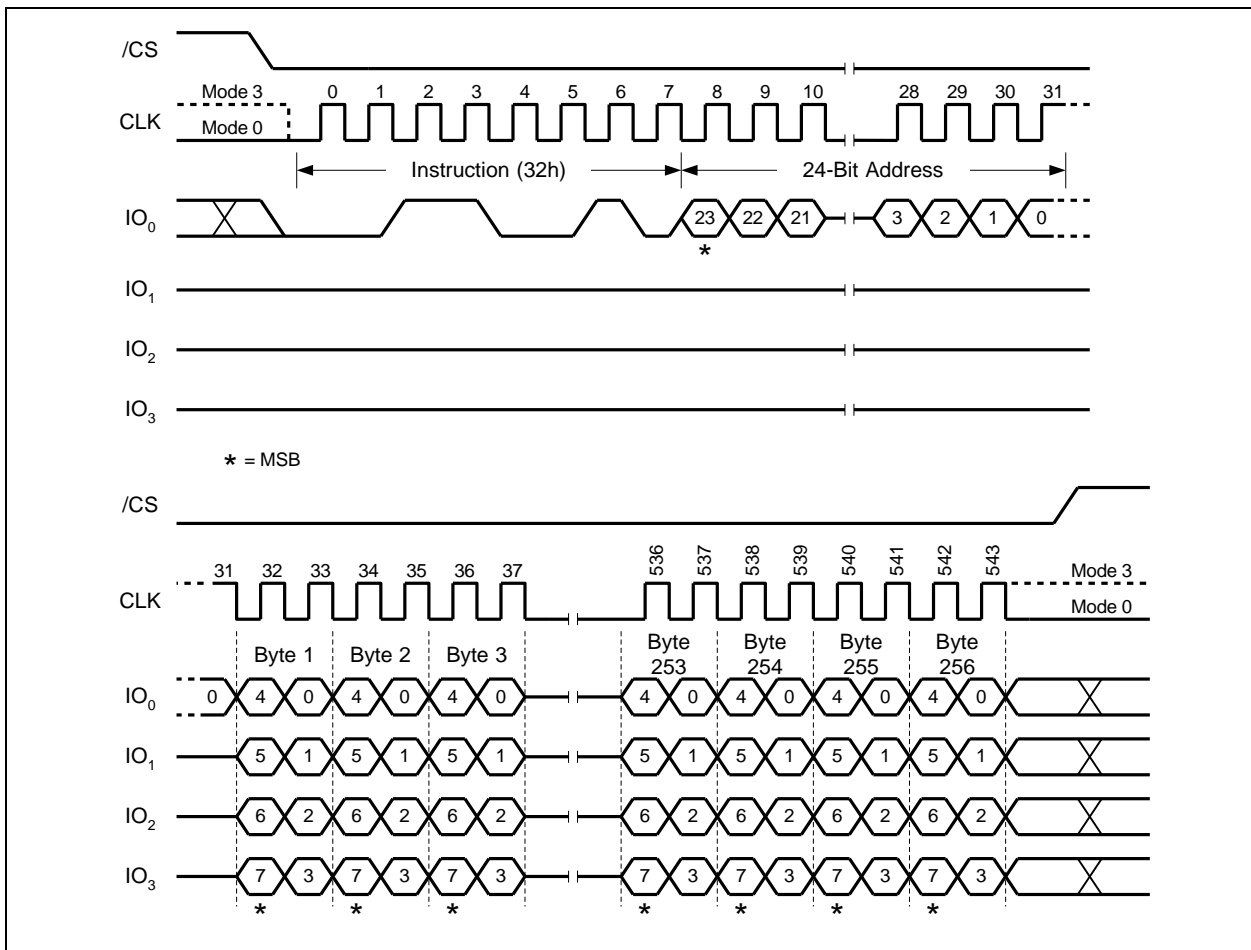

Figure 19. Quad Input Page Program Instruction



### 8.2.15 Sector Erase (20h)

The Sector Erase instruction sets all memory within a specified sector (4K-bytes) to the erased state of all 1s (FFh). A Write Enable instruction must be executed before the device will accept the Sector Erase Instruction (Status Register bit WEL must equal 1). The instruction is initiated by driving the /CS pin low and shifting the instruction code "20h" followed a 24-bit sector address (A23-A0). The Sector Erase instruction sequence is shown in Figure 20.

The /CS pin must be driven high after the eighth bit of the last byte has been latched. If this is not done the Sector Erase instruction will not be executed. After /CS is driven high, the self-timed Sector Erase instruction will commence for a time duration of  $t_{SE}$  (See AC Characteristics). While the Sector Erase cycle is in progress, the Read Status Register instruction may still be accessed for checking the status of the BUSY bit. The BUSY bit is a 1 during the Sector Erase cycle and becomes a 0 when the cycle is finished and the device is ready to accept other instructions again. After the Sector Erase cycle has finished the Write Enable Latch (WEL) bit in the Status Register is cleared to 0. The Sector Erase instruction will not be executed if the addressed page is protected by the Block Protect (CMP, SEC, TB, BP2, BP1, and BP0) bits or the Individual Block/Sector Locks.

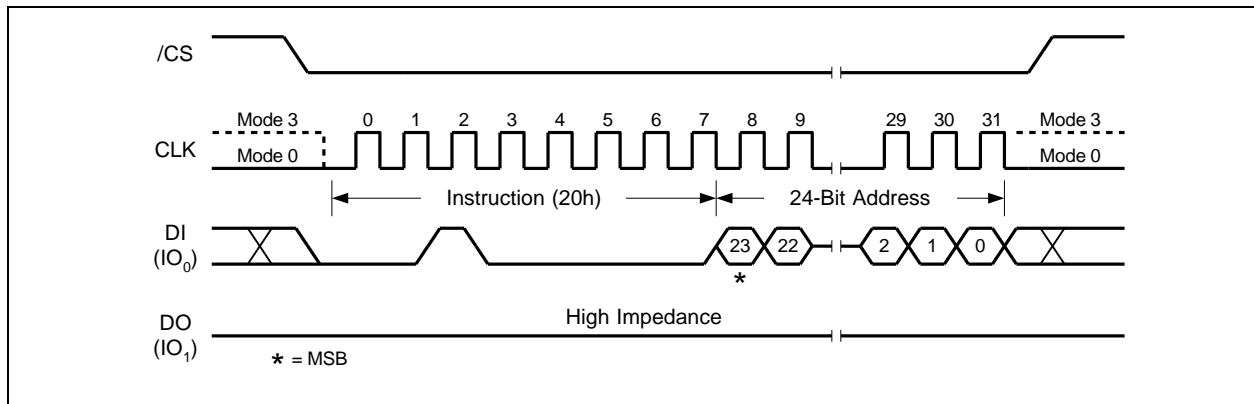

Figure 20. Sector Erase Instruction



### 8.2.16 32KB Block Erase (52h)

The Block Erase instruction sets all memory within a specified block (32K-bytes) to the erased state of all 1s (FFh). A Write Enable instruction must be executed before the device will accept the Block Erase Instruction (Status Register bit WEL must equal 1). The instruction is initiated by driving the /CS pin low and shifting the instruction code "52h" followed a 24-bit block address (A23-A0). The Block Erase instruction sequence is shown in Figure 21.

The /CS pin must be driven high after the eighth bit of the last byte has been latched. If this is not done the Block Erase instruction will not be executed. After /CS is driven high, the self-timed Block Erase instruction will commence for a time duration of  $t_{BE1}$  (See AC Characteristics). While the Block Erase cycle is in progress, the Read Status Register instruction may still be accessed for checking the status of the BUSY bit. The BUSY bit is a 1 during the Block Erase cycle and becomes a 0 when the cycle is finished and the device is ready to accept other instructions again. After the Block Erase cycle has finished the Write Enable Latch (WEL) bit in the Status Register is cleared to 0. The Block Erase instruction will not be executed if the addressed page is protected by the Block Protect (CMP, SEC, TB, BP2, BP1, and BP0) bits or the Individual Block/Sector Locks.

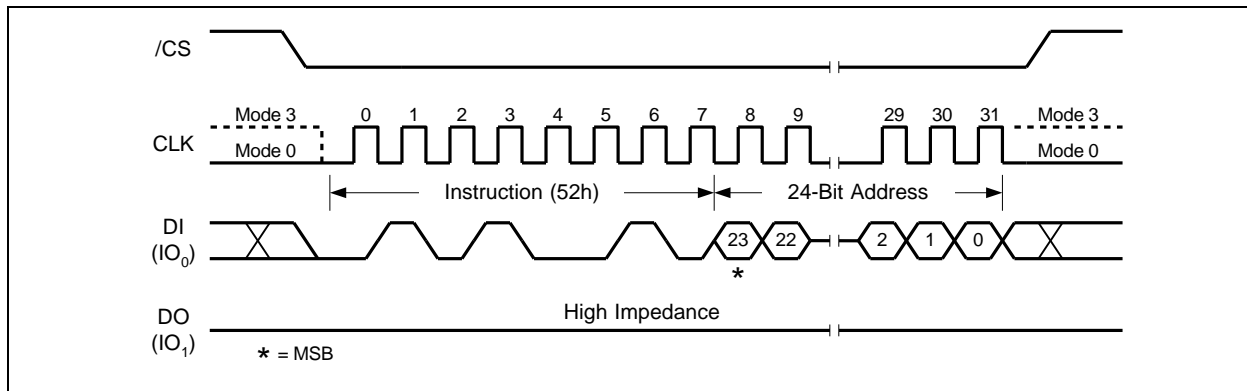

Figure 21. 32KB Block Erase Instruction



### 8.2.17 64KB Block Erase (D8h)

The Block Erase instruction sets all memory within a specified block (64K-bytes) to the erased state of all 1s (FFh). A Write Enable instruction must be executed before the device will accept the Block Erase Instruction (Status Register bit WEL must equal 1). The instruction is initiated by driving the /CS pin low and shifting the instruction code "D8h" followed a 24-bit block address (A23-A0). The Block Erase instruction sequence is shown in Figure 22.

The /CS pin must be driven high after the eighth bit of the last byte has been latched. If this is not done the Block Erase instruction will not be executed. After /CS is driven high, the self-timed Block Erase instruction will commence for a time duration of tBE (See AC Characteristics). While the Block Erase cycle is in progress, the Read Status Register instruction may still be accessed for checking the status of the BUSY bit. The BUSY bit is a 1 during the Block Erase cycle and becomes a 0 when the cycle is finished and the device is ready to accept other instructions again. After the Block Erase cycle has finished the Write Enable Latch (WEL) bit in the Status Register is cleared to 0. The Block Erase instruction will not be executed if the addressed page is protected by the Block Protect (CMP, SEC, TB, BP2, BP1, and BP0) bits or the Individual Block/Sector Locks.

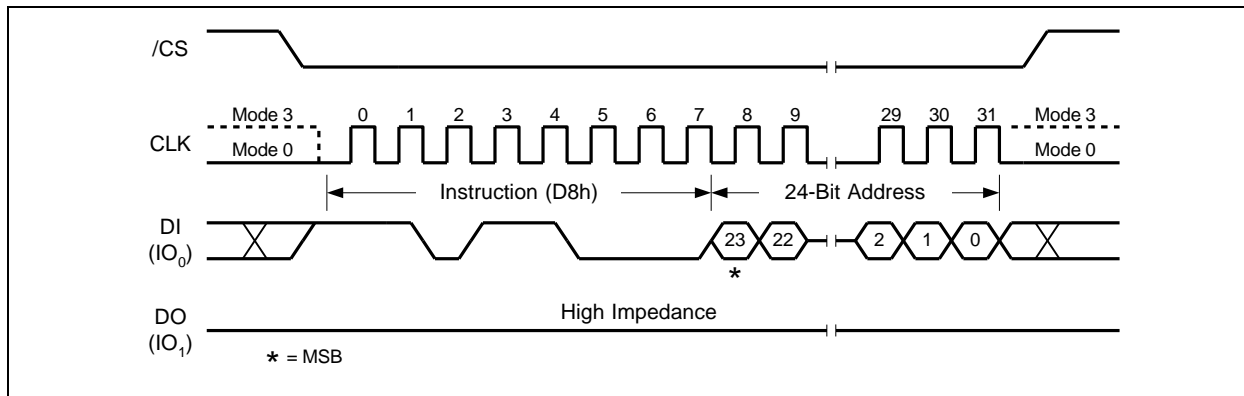

Figure 22. 64KB Block Erase Instruction





### 8.2.18 Chip Erase (C7h / 60h)

The Chip Erase instruction sets all memory within the device to the erased state of all 1s (FFh). A Write Enable instruction must be executed before the device will accept the Chip Erase Instruction (Status Register bit WEL must equal 1). The instruction is initiated by driving the /CS pin low and shifting the instruction code “C7h” or “60h”. The Chip Erase instruction sequence is shown in Figure 23.

The /CS pin must be driven high after the eighth bit has been latched. If this is not done the Chip Erase instruction will not be executed. After /CS is driven high, the self-timed Chip Erase instruction will commence for a time duration of tCE (See AC Characteristics). While the Chip Erase cycle is in progress, the Read Status Register instruction may still be accessed to check the status of the BUSY bit. The BUSY bit is a 1 during the Chip Erase cycle and becomes a 0 when finished and the device is ready to accept other instructions again. After the Chip Erase cycle has finished the Write Enable Latch (WEL) bit in the Status Register is cleared to 0. The Chip Erase instruction will not be executed if any memory region is protected by the Block Protect (CMP, SEC, TB, BP2, BP1, and BP0) bits or the Individual Block/Sector Locks.

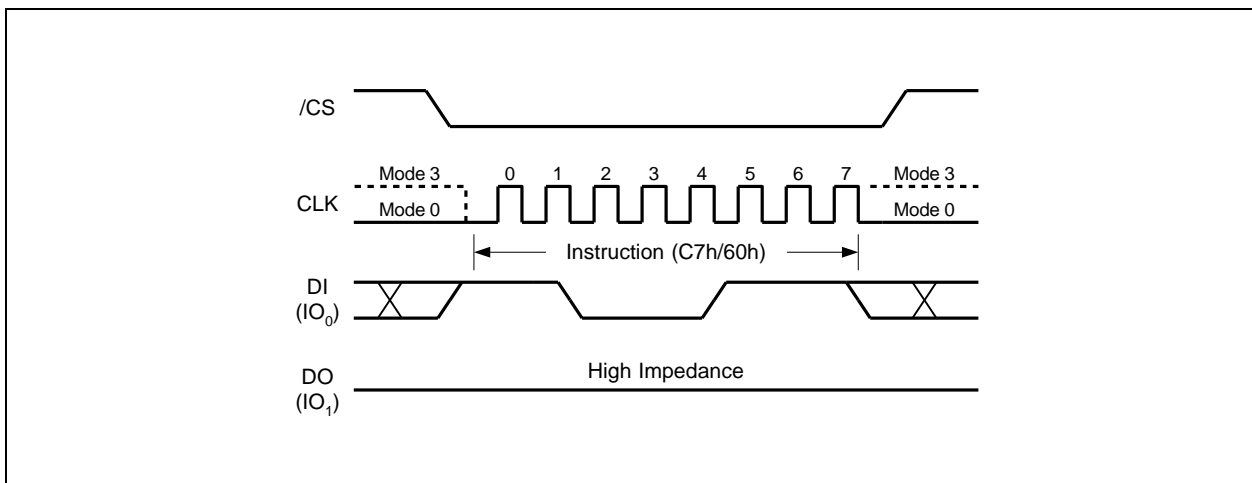

Figure 23. Chip Erase Instruction



### 8.2.19 Erase / Program Suspend (75h)

The Erase/Program Suspend instruction “75h”, allows the system to interrupt a Sector or Block Erase operation or a Page Program operation and then read from or program/erase data to, any other sectors or blocks. The Erase/Program Suspend instruction sequence is shown in Figure 24.

The Write Status Register instruction (01h) and Erase instructions (20h, 52h, D8h, C7h, 60h, 44h) are not allowed during Erase Suspend. Erase Suspend is valid only during the Sector or Block erase operation. If written during the Chip Erase operation, the Erase Suspend instruction is ignored. The Write Status Register instructions (01h, 31h, 11h) and Program instructions (02h, 32h, 42h) are not allowed during Program Suspend. Program Suspend is valid only during the Page Program or Quad Page Program operation.

The Erase/Program Suspend instruction “75h” will be accepted by the device only if the SUS bit in the Status Register equals to 0 and the BUSY bit equals to 1 while a Sector or Block Erase or a Page Program operation is on-going. If the SUS bit equals to 1 or the BUSY bit equals to 0, the Suspend instruction will be ignored by the device. A maximum of time of “ $t_{SUS}$ ” (See AC Characteristics) is required to suspend the erase or program operation. The BUSY bit in the Status Register will be cleared from 1 to 0 within “ $t_{SUS}$ ” and the SUS bit in the Status Register will be set from 0 to 1 immediately after Erase/Program Suspend. For a previously resumed Erase/Program operation, it is also required that the Suspend instruction “75h” is not issued earlier than a minimum of time of “ $t_{SUS}$ ” following the preceding Resume instruction “7Ah”.

Unexpected power off during the Erase/Program suspend state will reset the device and release the suspend state. SUS bit in the Status Register will also reset to 0. The data within the page, sector or block that was being suspended may become corrupted. It is recommended for the user to implement system design techniques against the accidental power interruption and preserve data integrity during erase/program suspend state.

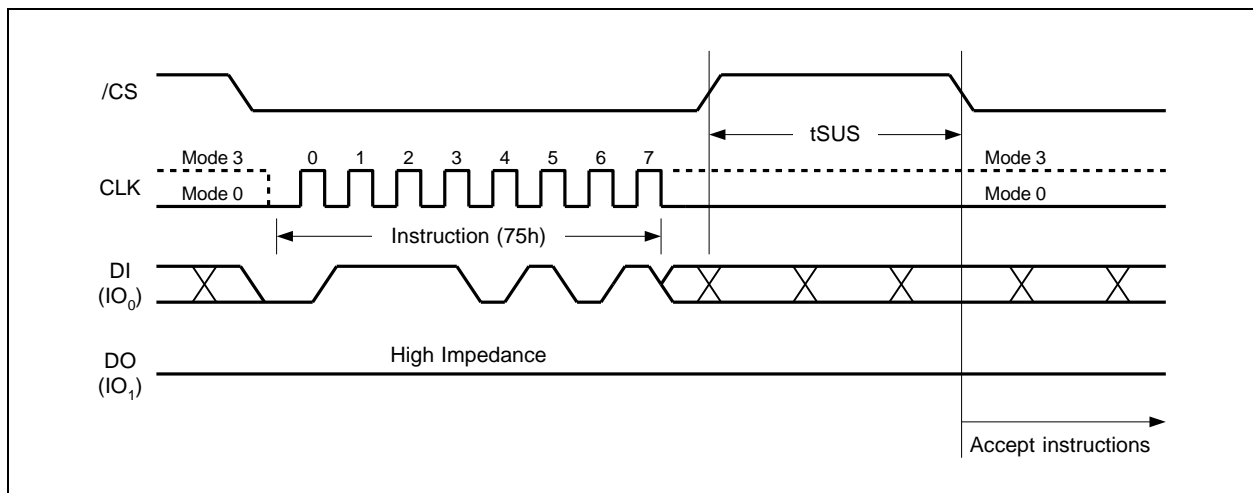

Figure 24. Erase/Program Suspend Instruction



### 8.2.20 Erase / Program Resume (7Ah)

The Erase/Program Resume instruction “7Ah” must be written to resume the Sector or Block Erase operation or the Page Program operation after an Erase/Program Suspend. The Resume instruction “7Ah” will be accepted by the device only if the SUS bit in the Status Register equals to 1 and the BUSY bit equals to 0. After issued the SUS bit will be cleared from 1 to 0 immediately, the BUSY bit will be set from 0 to 1 within 200ns and the Sector or Block will complete the erase operation or the page will complete the program operation. If the SUS bit equals to 0 or the BUSY bit equals to 1, the Resume instruction “7Ah” will be ignored by the device. The Erase/Program Resume instruction sequence is shown in Figure 25.

Resume instruction is ignored if the previous Erase/Program Suspend operation was interrupted by unexpected power off. It is also required that a subsequent Erase/Program Suspend instruction not to be issued within a minimum of time of “ $t_{sus}$ ” following a previous Resume instruction.

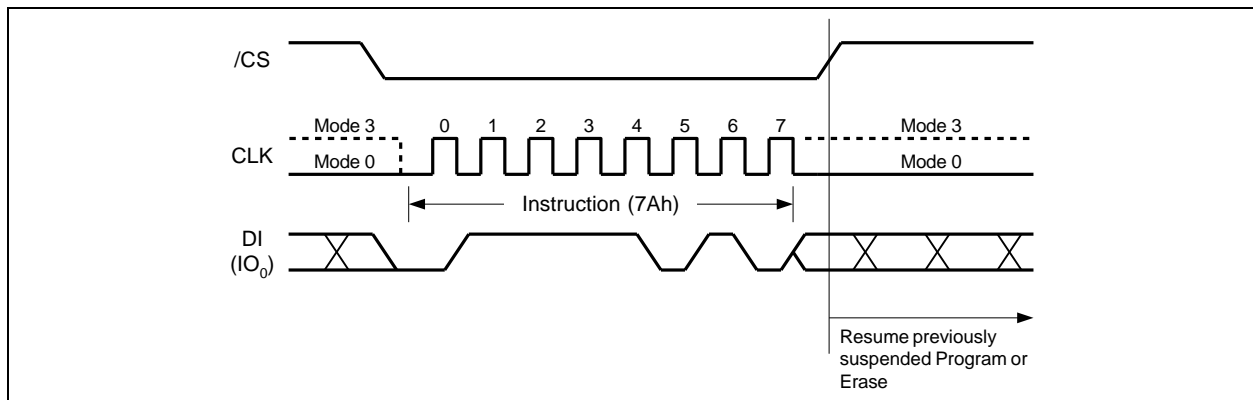

Figure 25. Erase/Program Resume Instruction



### 8.2.21 Power-down (B9h)

Although the standby current during normal operation is relatively low, standby current can be further reduced with the Power-down instruction. The lower power consumption makes the Power-down instruction especially useful for battery powered applications (See ICC1 and ICC2 in AC Characteristics). The instruction is initiated by driving the /CS pin low and shifting the instruction code "B9h" as shown in Figure 26.

The /CS pin must be driven high after the eighth bit has been latched. If this is not done the Power-down instruction will not be executed. After /CS is driven high, the power-down state will be entered within the time duration of  $t_{DP}$  (See AC Characteristics). While in the power-down state only the Release Power-down / Device ID (ABh) instruction, which restores the device to normal operation, will be recognized. All other instructions are ignored. This includes the Read Status Register instruction, which is always available during normal operation. Ignoring all but one instruction makes the Power Down state a useful condition for securing maximum write protection. The device always powers-up in the normal operation with the standby current of ICC1.

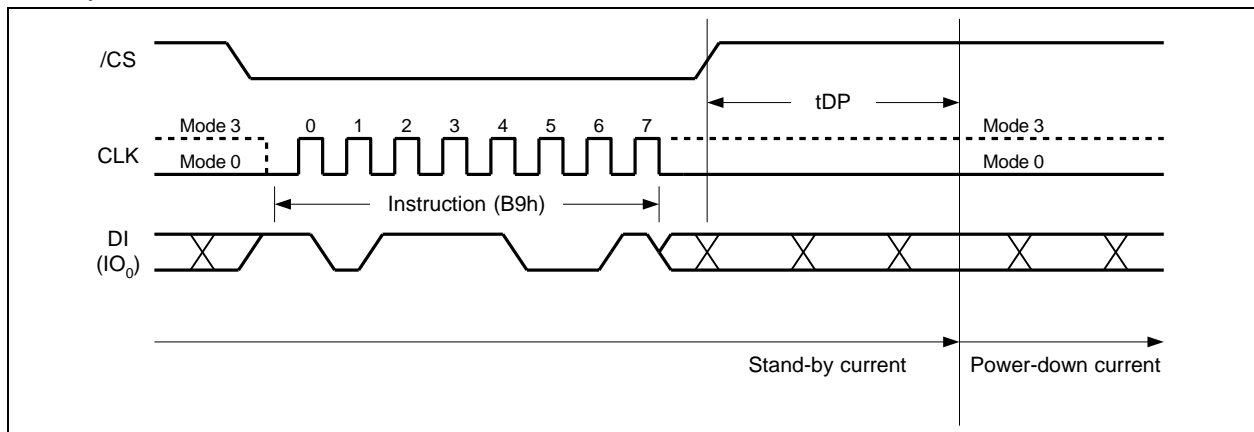

Figure 26. Deep Power-down Instruction



**8.2.22 Release Power-down / Device ID (ABh)**

The Release from Power-down / Device ID instruction is a multi-purpose instruction. It can be used to release the device from the power-down state, or obtain the devices electronic identification (ID) number.

To release the device from the power-down state, the instruction is issued by driving the /CS pin low, shifting the instruction code “ABh” and driving /CS high as shown in Figure 27a. Release from power-down will take the time duration of tRES1 (See AC Characteristics) before the device will resume normal operation and other instructions are accepted. The /CS pin must remain high during the tRES1 time duration.

When used only to obtain the Device ID while not in the power-down state, the instruction is initiated by driving the /CS pin low and shifting the instruction code “ABh” followed by 3-dummy bytes. The Device ID bits are then shifted out on the falling edge of CLK with most significant bit (MSB) first. The Device ID value for the W25R128JV is listed in Manufacturer and Device Identification table. The Device ID can be read continuously. The instruction is completed by driving /CS high.

When used to release the device from the power-down state and obtain the Device ID, the instruction is the same as previously described, and shown in Figure 27b, except that after /CS is driven high it must remain high for a time duration of tRES2 (See AC Characteristics). After this time duration the device will resume normal operation and other instructions will be accepted. If the Release from Power-down / Device ID instruction is issued while an Erase, Program or Write cycle is in process (when BUSY equals 1) the instruction is ignored and will not have any effects on the current cycle.

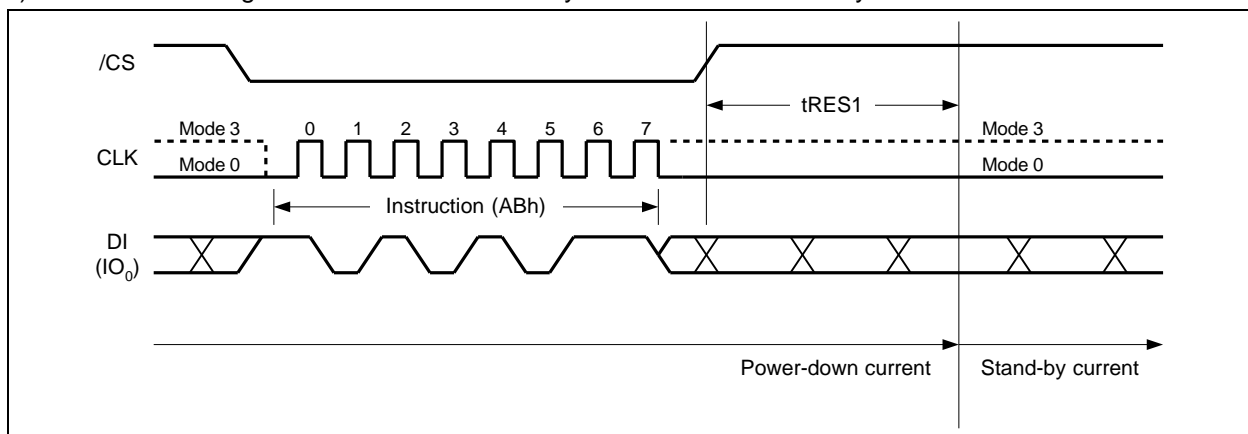

Figure 27a. Release Power-down Instruction

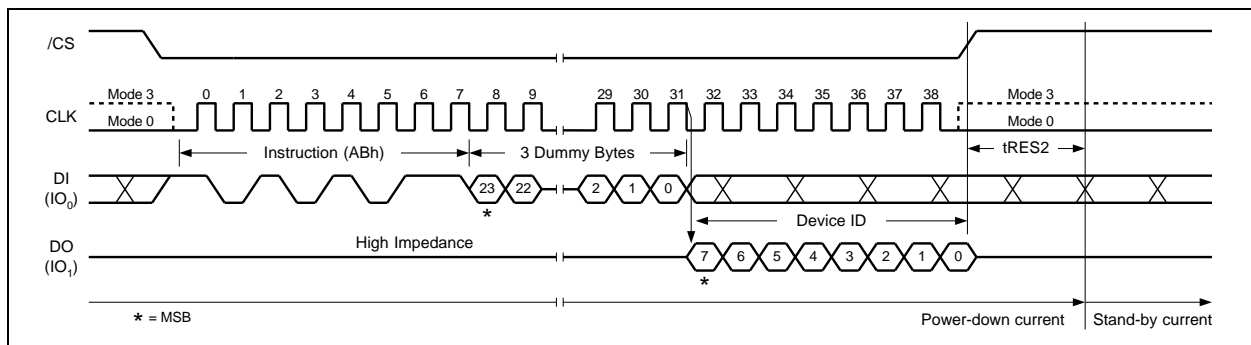

Figure 27b. Release Power-down / Device ID Instruction



**8.2.23 Read Manufacturer / Device ID (90h)**

The Read Manufacturer/Device ID instruction is an alternative to the Release from Power-down / Device ID instruction that provides both the JEDEC assigned manufacturer ID and the specific device ID.

The Read Manufacturer/Device ID instruction is very similar to the Release from Power-down / Device ID instruction. The instruction is initiated by driving the /CS pin low and shifting the instruction code “90h” followed by a 24-bit address (A23-A0) of 000000h. After which, the Manufacturer ID for Winbond (EFh) and the Device ID are shifted out on the falling edge of CLK with most significant bit (MSB) first as shown in Figure 28. The Device ID values for the W25R128JV are listed in Manufacturer and Device Identification table. The instruction is completed by driving /CS high.

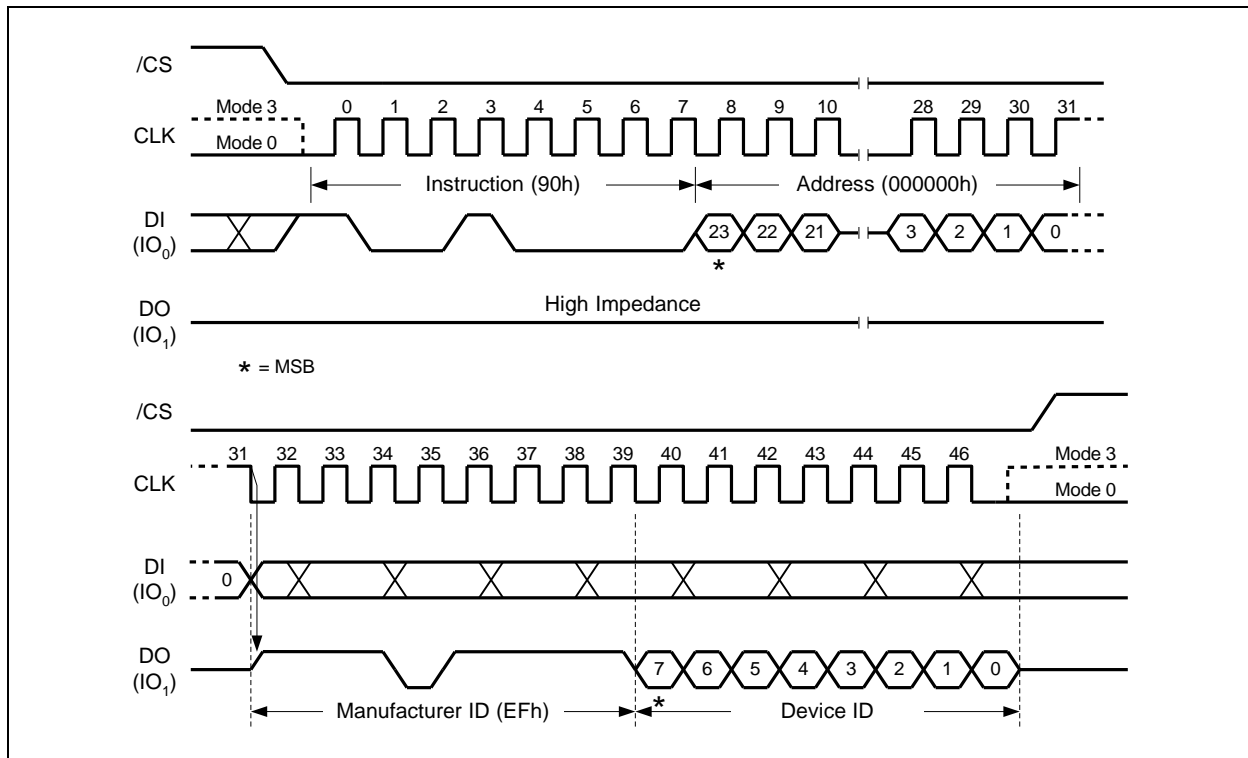

Figure 28. Read Manufacturer / Device ID Instruction





**8.2.25 Read Manufacturer / Device ID Quad I/O (94h)**

The Read Manufacturer / Device ID Quad I/O instruction is an alternative to the Read Manufacturer / Device ID instruction that provides both the JEDEC assigned manufacturer ID and the specific device ID at 4x speed.

The Read Manufacturer / Device ID Quad I/O instruction is similar to the Fast Read Quad I/O instruction. The instruction is initiated by driving the /CS pin low and shifting the instruction code “94h” followed by a four clock dummy cycles and then a 24-bit address (A23-A0) of 000000h, but with the capability to input the Address bits four bits per clock. After which, the Manufacturer ID for Winbond (EFh) and the Device ID are shifted out four bits per clock on the falling edge of CLK with most significant bit (MSB) first as shown in Figure 30. The Device ID values for the W25R128JV are listed in Manufacturer and Device Identification table. If the 24-bit address is initially set to 000001h the Device ID will be read first and then followed by the Manufacturer ID. The Manufacturer and Device IDs can be read continuously, alternating from one to the other. The instruction is completed by driving /CS high.

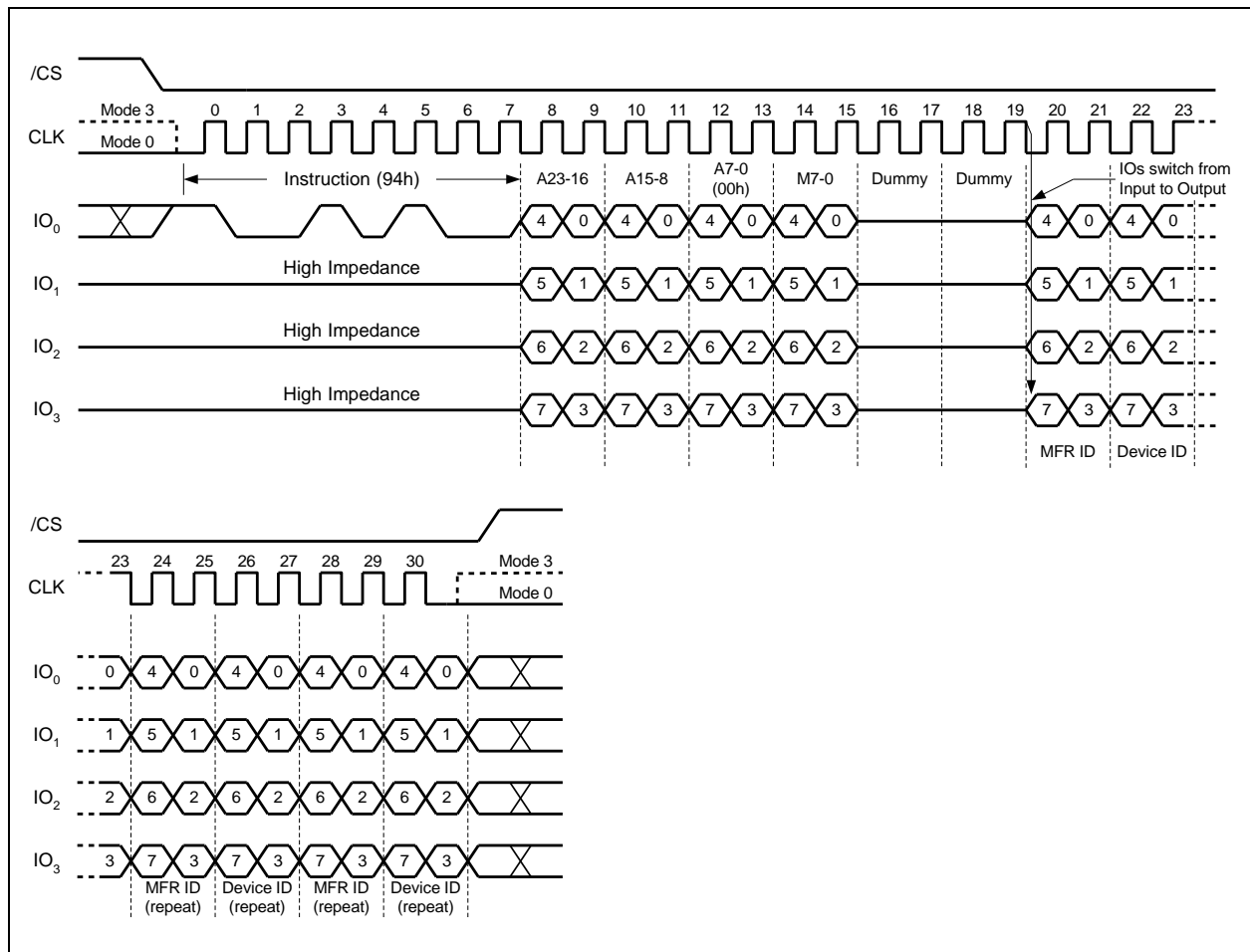

Figure 30. Read Manufacturer / Device ID Quad I/O Instruction





**8.2.26 Read Unique ID Number (4Bh)**

The Read Unique ID Number instruction accesses a factory-set read-only 64-bit number that is unique to each W25R128JV device. The ID number can be used in conjunction with user software methods to help prevent copying or cloning of a system. The Read Unique ID instruction is initiated by driving the /CS pin low and shifting the instruction code “4Bh” followed by a four bytes of dummy clocks. After which, the 64-bit ID is shifted out on the falling edge of CLK as shown in Figure 31.

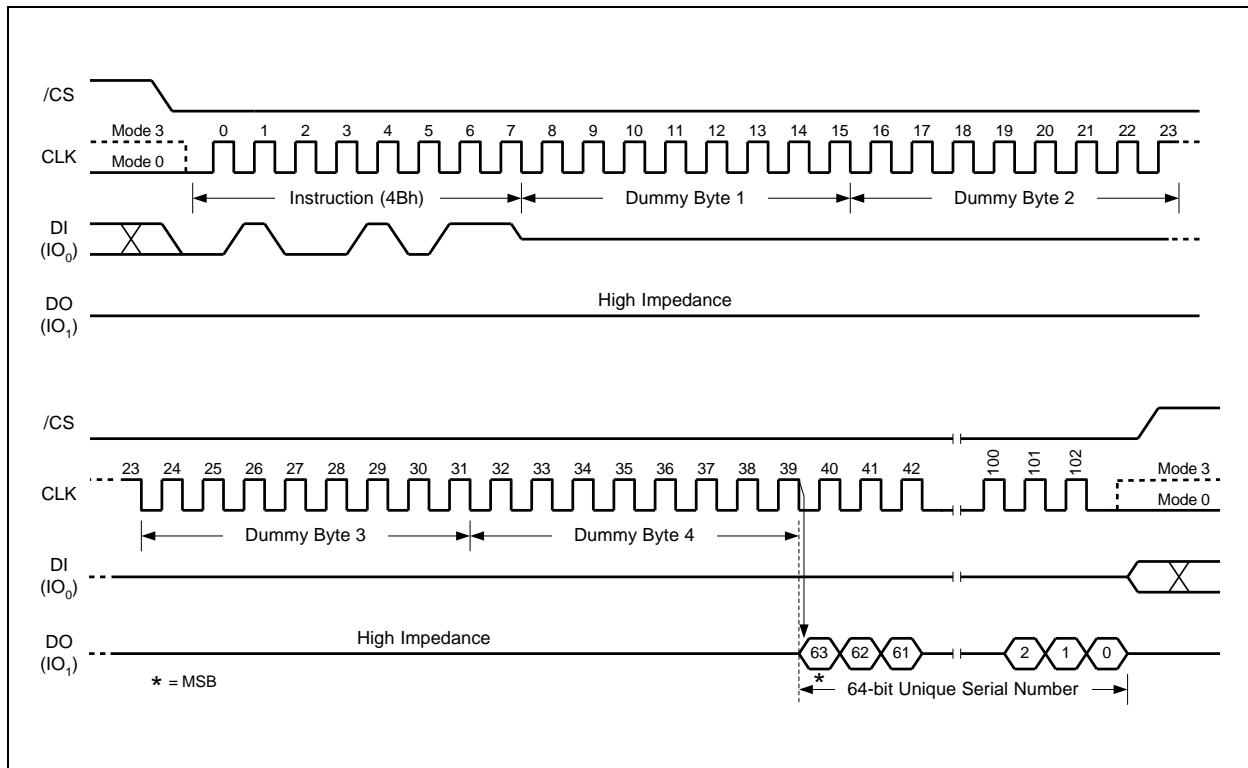

Figure 31. Read Unique ID Number Instruction



**8.2.27 Read JEDEC ID (9Fh)**

For compatibility reasons, the W25R128JV provides several instructions to electronically determine the identity of the device. The Read JEDEC ID instruction is compatible with the JEDEC standard for SPI compatible serial memories that was adopted in 2003. The instruction is initiated by driving the /CS pin low and shifting the instruction code “9Fh”. The JEDEC assigned Manufacturer ID byte for Winbond (EFh) and two Device ID bytes, Memory Type (ID15-ID8) and Capacity (ID7-ID0) are then shifted out on the falling edge of CLK with most significant bit (MSB) first as shown in Figure 32. For memory type and capacity values refer to Manufacturer and Device Identification table.

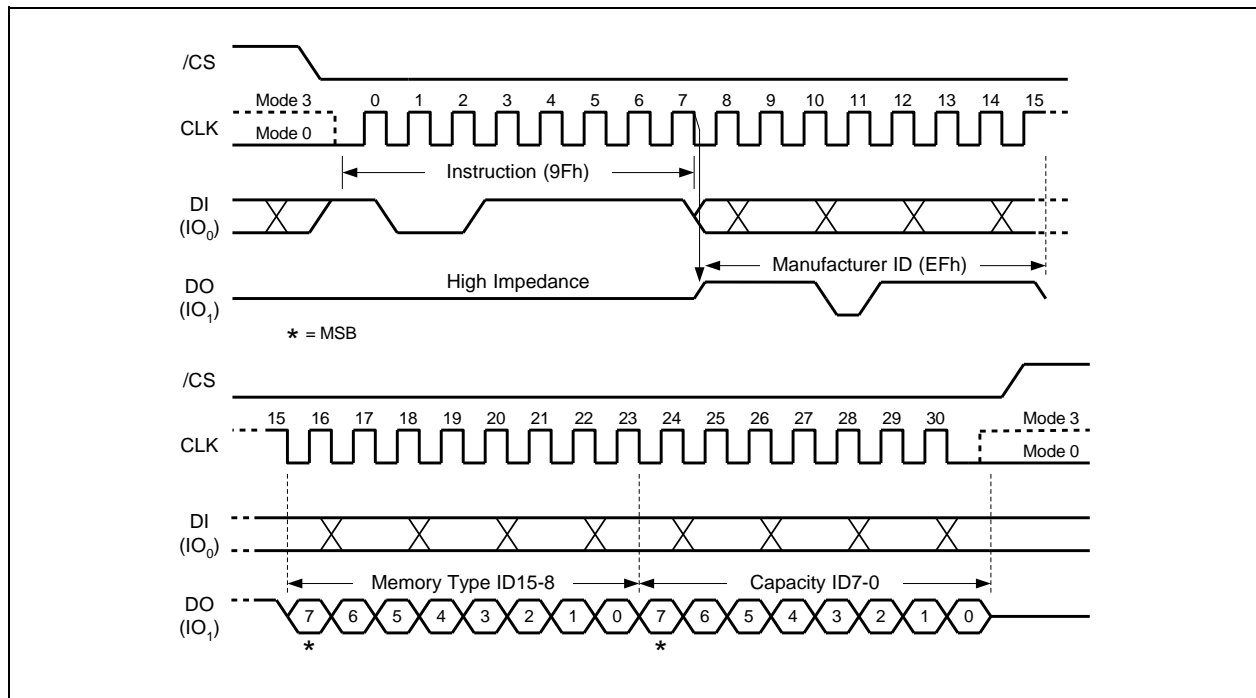

Figure 32. Read JEDEC ID Instruction



**8.2.28 Read SFDP Register (5Ah)**

The W25R128JV features a 256-Byte Serial Flash Discoverable Parameter (SFDP) register that contains information about device configurations, available instructions and other features. The SFDP parameters are stored in one or more Parameter Identification (PID) tables. Currently two PID table is specified, but more may be added in the future. The Read SFDP Register instruction is compatible with the SFDP standard initially established in 2010 for PC and other applications, as well as the JEDEC standard JESD216 that is published in 2011. Most Winbond SpiFlash Memories shipped after June 2011 (date code 1124 and beyond) support the SFDP feature as specified in the applicable datasheet.

The Read SFDP instruction is initiated by driving the /CS pin low and shifting the instruction code “5Ah” followed by a 24-bit address (A23-A0)<sup>(1)</sup> into the DI pin. Eight “dummy” clocks are also required before the SFDP register contents are shifted out on the falling edge of the 40<sup>th</sup> CLK with most significant bit (MSB) first as shown in Figure 33. For SFDP register values and descriptions, please refer to the following SFDP Definition table.

Note 1: A23-A8 = 0; A7-A0 are used to define the starting byte address for the 256-Byte SFDP Register.

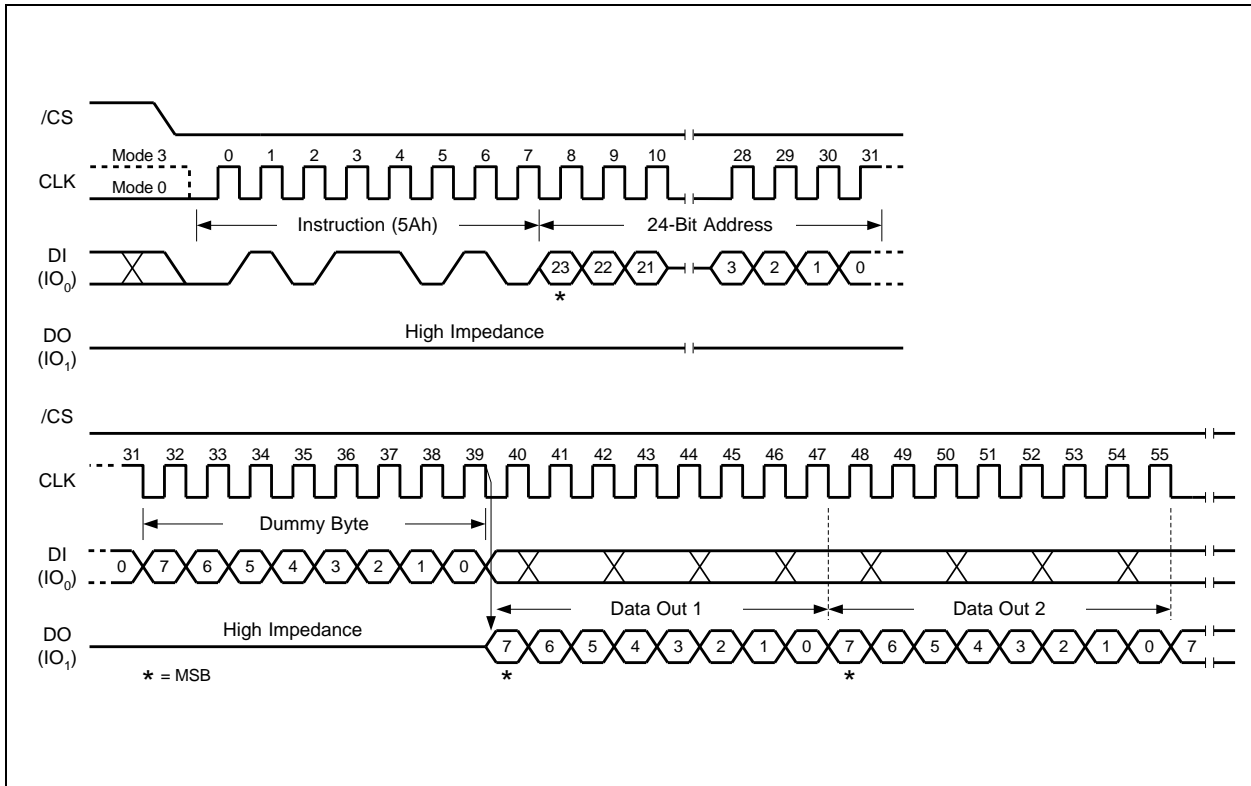

Figure 33. Read SFDP Register Instruction



**8.2.29 Erase Security Registers (44h)**

The W25R128JV offers three 256-byte Security Registers which can be erased and programmed individually. These registers may be used by the system manufacturers to store security and other important information separately from the main memory array.

The Erase Security Register instruction is similar to the Sector Erase instruction. A Write Enable instruction must be executed before the device will accept the Erase Security Register Instruction (Status Register bit WEL must equal 1). The instruction is initiated by driving the /CS pin low and shifting the instruction code “44h” followed by a 24-bit address (A23-A0) to erase one of the three security registers.

ADDRESS	A23-16	A15-12	A11-8	A7-0
Security Register #1	00h	0 0 0 1	0 0 0 0	Don't Care
Security Register #2	00h	0 0 1 0	0 0 0 0	Don't Care
Security Register #3	00h	0 0 1 1	0 0 0 0	Don't Care

The Erase Security Register instruction sequence is shown in Figure 34. The /CS pin must be driven high after the eighth bit of the last byte has been latched. If this is not done the instruction will not be executed. After /CS is driven high, the self-timed Erase Security Register operation will commence for a time duration of tSE (See AC Characteristics). While the Erase Security Register cycle is in progress, the Read Status Register instruction may still be accessed for checking the status of the BUSY bit. The BUSY bit is a 1 during the erase cycle and becomes a 0 when the cycle is finished and the device is ready to accept other instructions again. After the Erase Security Register cycle has finished the Write Enable Latch (WEL) bit in the Status Register is cleared to 0. The Security Register Lock Bits (LB3-1) in the Status Register-2 can be used to OTP protect the security registers. Once a lock bit is set to 1, the corresponding security register will be permanently locked, Erase Security Register instruction to that register will be ignored (Refer to section 7.1.9 for detail descriptions).

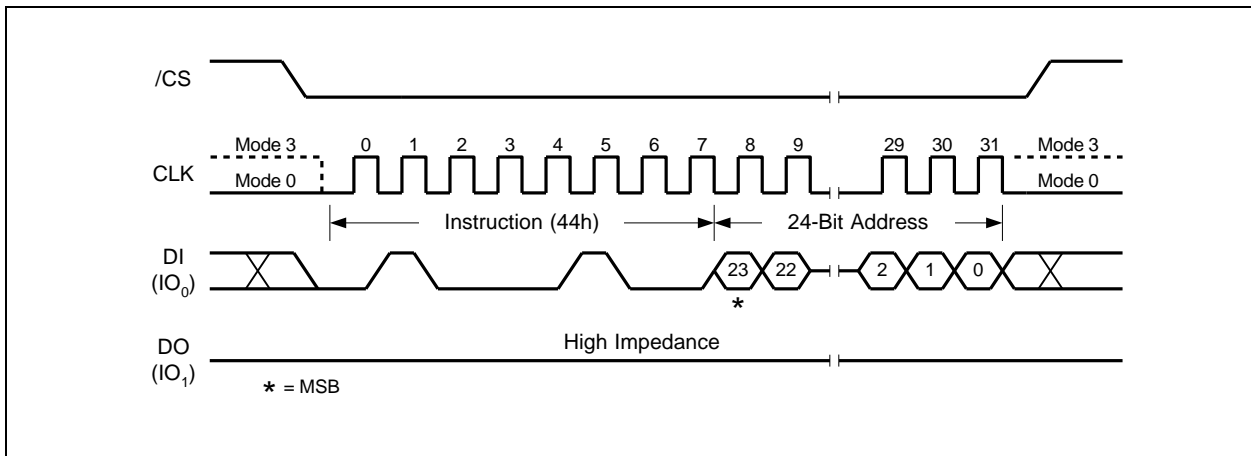

Figure 34. Erase Security Registers Instruction



**8.2.30 Program Security Registers (42h)**

The Program Security Register instruction is similar to the Page Program instruction. It allows from one byte to 256 bytes of security register data to be programmed at previously erased (FFh) memory locations. A Write Enable instruction must be executed before the device will accept the Program Security Register Instruction (Status Register bit WEL= 1). The instruction is initiated by driving the /CS pin low then shifting the instruction code “42h” followed by a 24-bit address (A23-A0) and at least one data byte, into the DI pin. The /CS pin must be held low for the entire length of the instruction while data is being sent to the device.

ADDRESS	A23-16	A15-12	A11-8	A7-0
Security Register #1	00h	0 0 0 1	0 0 0 0	Byte Address
Security Register #2	00h	0 0 1 0	0 0 0 0	Byte Address
Security Register #3	00h	0 0 1 1	0 0 0 0	Byte Address

The Program Security Register instruction sequence is shown in Figure 35. The Security Register Lock Bits (LB3-1) in the Status Register-2 can be used to OTP protect the security registers. Once a lock bit is set to 1, the corresponding security register will be permanently locked, Program Security Register instruction to that register will be ignored (See 7.1.9, 8.2.13 for detail descriptions).

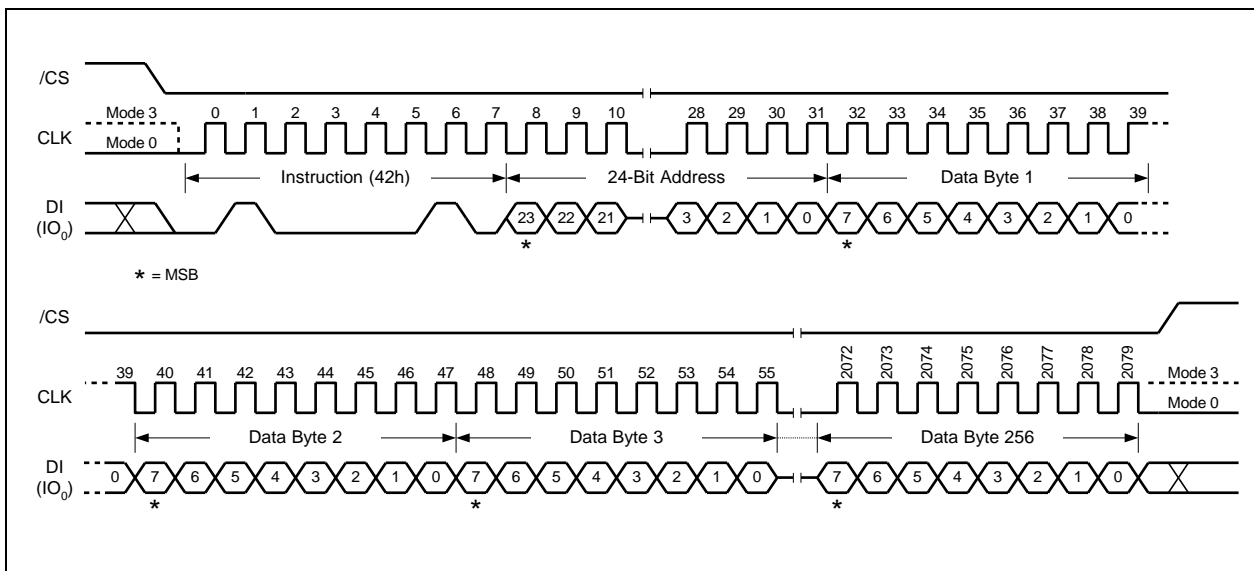

Figure 35. Program Security Registers Instruction



**8.2.31 Read Security Registers (48h)**

The Read Security Register instruction is similar to the Fast Read instruction and allows one or more data bytes to be sequentially read from one of the four security registers. The instruction is initiated by driving the /CS pin low and then shifting the instruction code “48h” followed by a 24-bit address (A23-A0) and eight “dummy” clocks into the DI pin. The code and address bits are latched on the rising edge of the CLK pin. After the address is received, the data byte of the addressed memory location will be shifted out on the DO pin at the falling edge of CLK with most significant bit (MSB) first. The byte address is automatically incremented to the next byte address after each byte of data is shifted out. Once the byte address reaches the last byte of the register (byte address FFh), it will reset to address 00h, the first byte of the register, and continue to increment. The instruction is completed by driving /CS high. The Read Security Register instruction sequence is shown in Figure 36. If a Read Security Register instruction is issued while an Erase, Program or Write cycle is in process (BUSY=1) the instruction is ignored and will not have any effects on the current cycle. The Read Security Register instruction allows clock rates from D.C. to a maximum of FR (see AC Electrical Characteristics).

ADDRESS	A23-16	A15-12	A11-8	A7-0
Security Register #1	00h	0 0 0 1	0 0 0 0	Byte Address
Security Register #2	00h	0 0 1 0	0 0 0 0	Byte Address
Security Register #3	00h	0 0 1 1	0 0 0 0	Byte Address

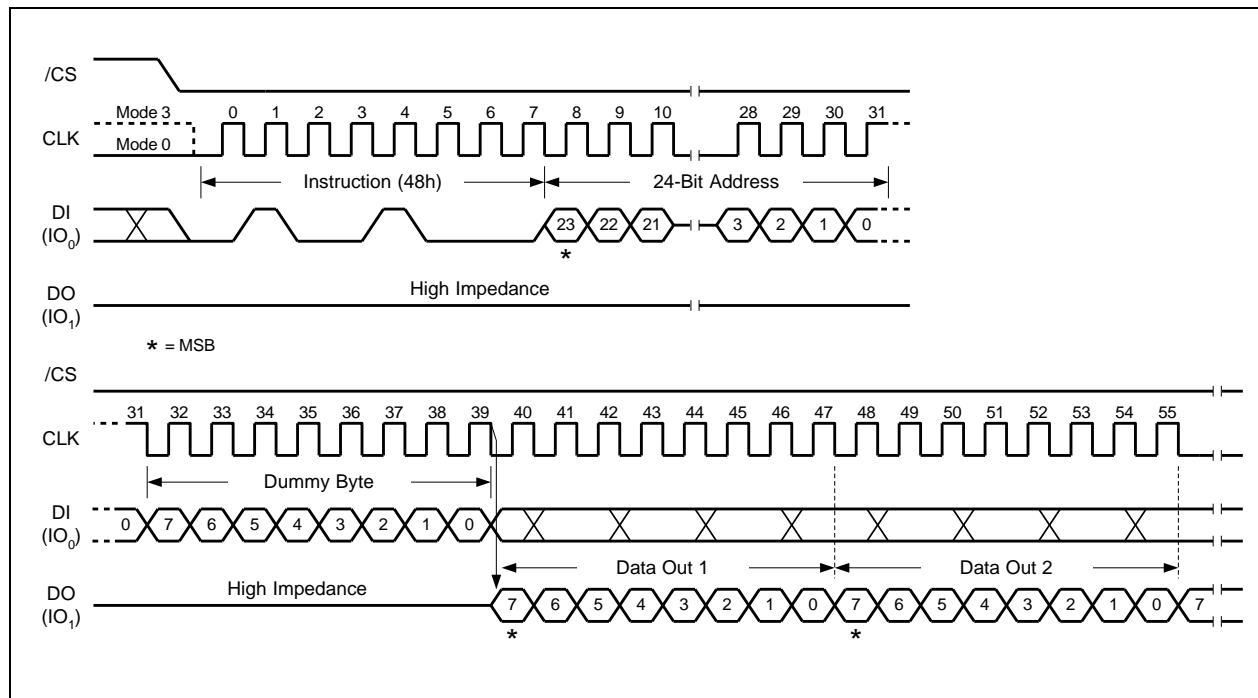

Figure 36. Read Security Registers Instruction



### 8.2.32 Individual Block/Sector Lock (36h)

The Individual Block/Sector Lock provides an alternative way to protect the memory array from adverse Erase/Program. In order to use the Individual Block/Sector Locks, the WPS bit in Status Register-3 must be set to 1. If WPS=0, the write protection will be determined by the combination of CMP, SEC, TB, BP[2:0] bits in the Status Registers. The Individual Block/Sector Lock bits are volatile bits. The default values after device power up or after a Reset are 1, so the entire memory array is being protected.

To lock a specific block or sector as illustrated in Figure 5, an Individual Block/Sector Lock command must be issued by driving /CS low, shifting the instruction code "36h" into the Data Input (DI) pin on the rising edge of CLK, followed by a 24-bit address and then driving /CS high. A Write Enable instruction must be executed before the device will accept the Individual Block/Sector Lock Instruction (Status Register bit WEL= 1).

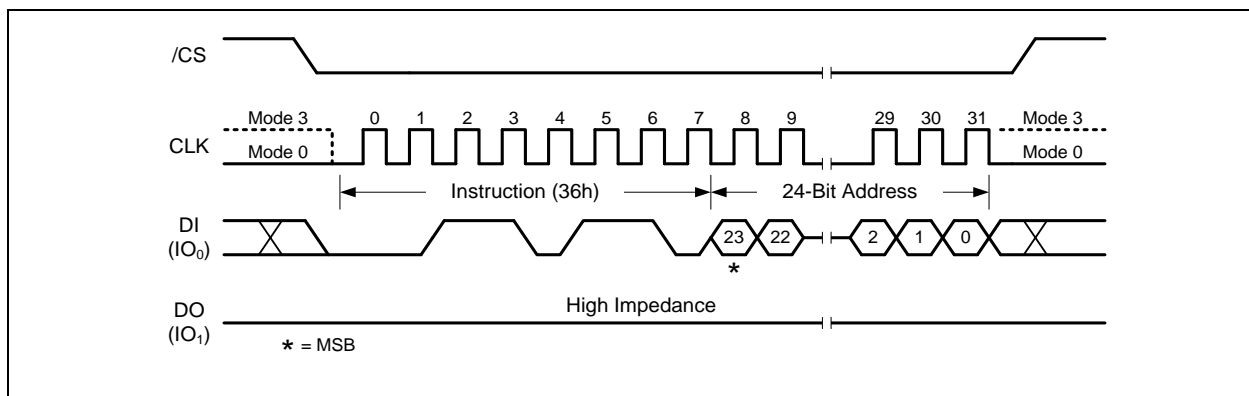

Figure 37. Individual Block/Sector Lock Instruction



### 8.2.33 Individual Block/Sector Unlock (39h)

The Individual Block/Sector Lock provides an alternative way to protect the memory array from adverse Erase/Program. In order to use the Individual Block/Sector Locks, the WPS bit in Status Register-3 must be set to 1. If WPS=0, the write protection will be determined by the combination of CMP, SEC, TB, BP[2:0] bits in the Status Registers. The Individual Block/Sector Lock bits are volatile bits. The default values after device power up or after a Reset are 1, so the entire memory array is being protected.

To unlock a specific block or sector as illustrated in Figure 5, an Individual Block/Sector Unlock command must be issued by driving /CS low, shifting the instruction code "39h" into the Data Input (DI) pin on the rising edge of CLK, followed by a 24-bit address and then driving /CS high. A Write Enable instruction must be executed before the device will accept the Individual Block/Sector Unlock Instruction (Status Register bit WEL= 1).

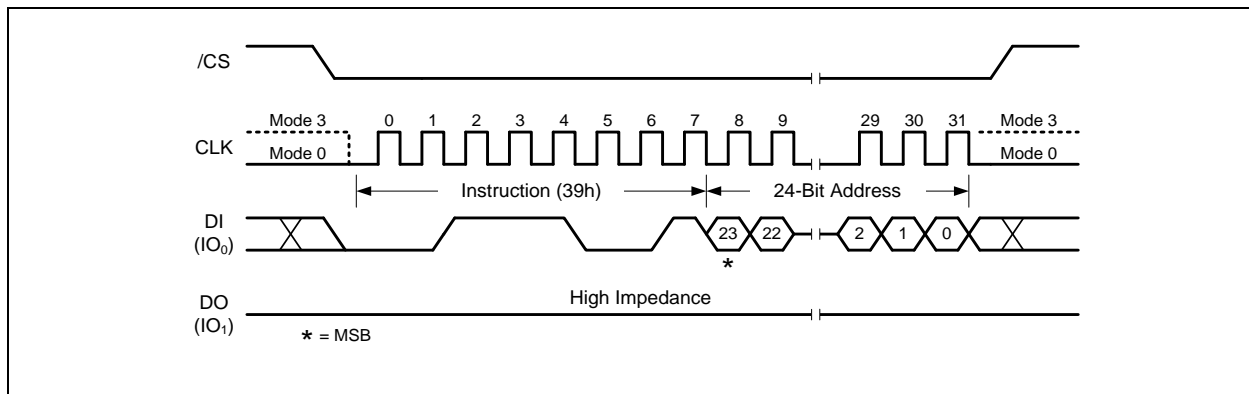

Figure 38. Individual Block Unlock Instruction





### 8.2.34 Read Block/Sector Lock (3Dh)

The Individual Block/Sector Lock provides an alternative way to protect the memory array from adverse Erase/Program. In order to use the Individual Block/Sector Locks, the WPS bit in Status Register-3 must be set to 1. If WPS=0, the write protection will be determined by the combination of CMP, SEC, TB, BP[2:0] bits in the Status Registers. The Individual Block/Sector Lock bits are volatile bits. The default values after device power up or after a Reset are 1, so the entire memory array is being protected.

To read out the lock bit value of a specific block or sector as illustrated in Figure 5, a Read Block/Sector Lock command must be issued by driving /CS low, shifting the instruction code "3Dh" into the Data Input (DI) pin on the rising edge of CLK, followed by a 24-bit address. The Block/Sector Lock bit value will be shifted out on the DO pin at the falling edge of CLK with most significant bit (MSB) first as shown in Figure 54. If the least significant bit (LSB) is 1, the corresponding block/sector is locked; if LSB=0, the corresponding block/sector is unlocked, Erase/Program operation can be performed.

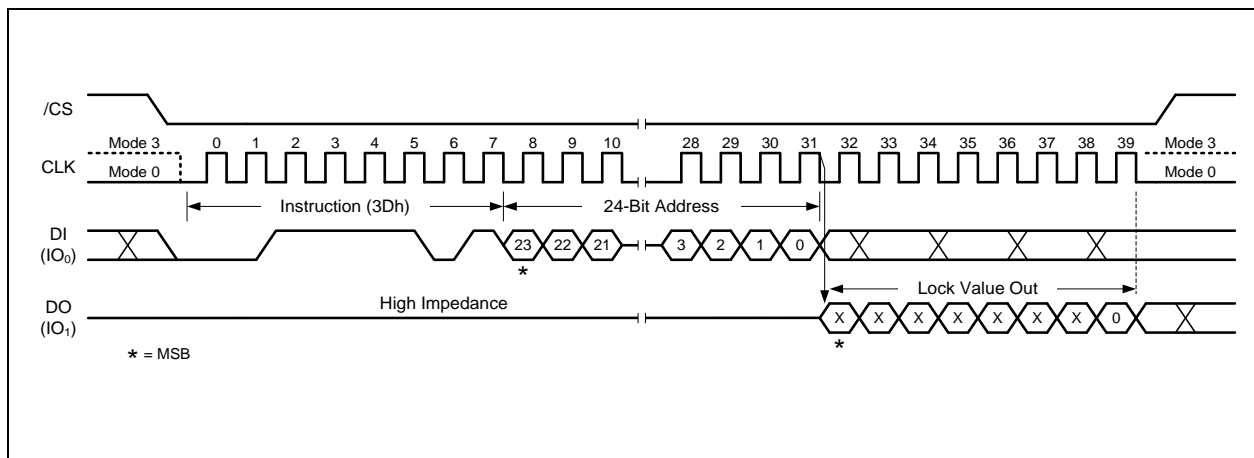

Figure 39. Read Block Lock Instruction



### 8.2.35 Global Block/Sector Lock (7Eh)

All Block/Sector Lock bits can be set to 1 by the Global Block/Sector Lock instruction. The command must be issued by driving /CS low, shifting the instruction code "7Eh" into the Data Input (DI) pin on the rising edge of CLK, and then driving /CS high. A Write Enable instruction must be executed before the device will accept the Global Block/Sector Lock Instruction (Status Register bit WEL= 1).

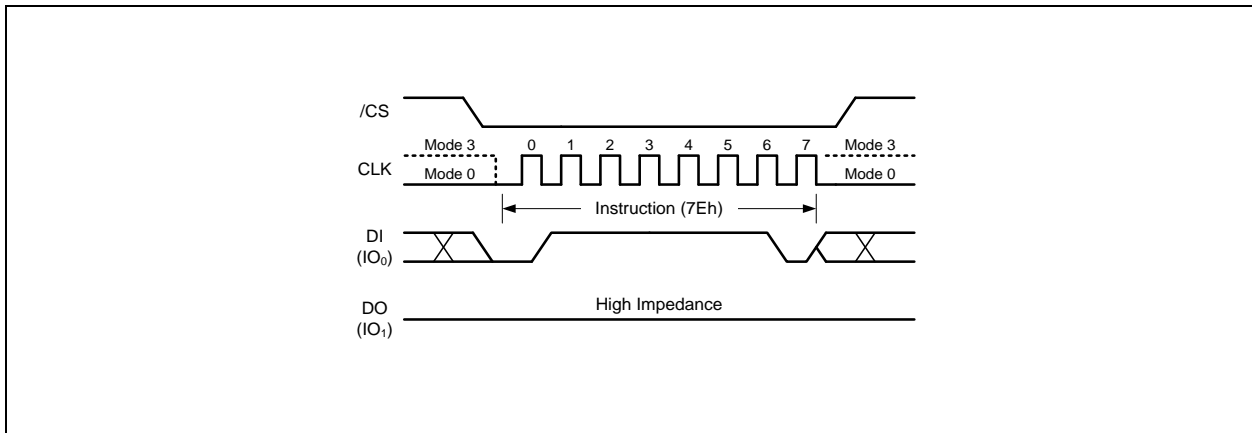

Figure 40. Global Block Lock Instruction

### 8.2.36 Global Block/Sector Unlock (98h)

All Block/Sector Lock bits can be set to 0 by the Global Block/Sector Unlock instruction. The command must be issued by driving /CS low, shifting the instruction code "98h" into the Data Input (DI) pin on the rising edge of CLK, and then driving /CS high. A Write Enable instruction must be executed before the device will accept the Global Block/Sector Unlock Instruction (Status Register bit WEL= 1).

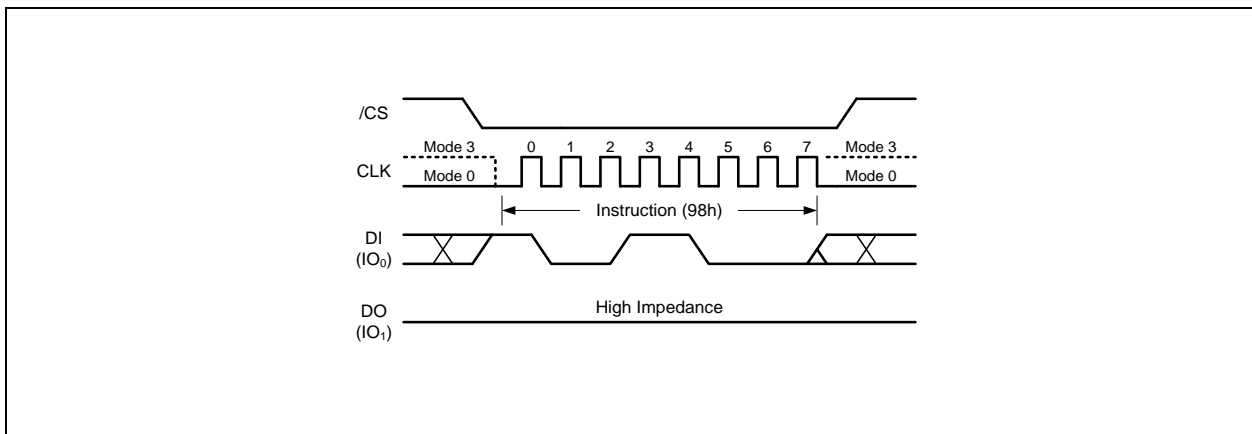

Figure 41. Global Block Unlock Instruction



### 8.2.37 Enable Reset (66h) and Reset Device (99h)

Because of the small package and the limitation on the number of pins, the W25R128JV provide a software Reset instruction instead of a dedicated RESET pin. Once the Reset instruction is accepted, any on-going internal operations will be terminated and the device will return to its default power-on state and lose all the current volatile settings, such as Volatile Status Register bits, Write Enable Latch (WEL) status, Program/Erase Suspend status, Read parameter setting (P7-P0) and Wrap Bit setting (W6-W4).

To avoid accidental reset, both instructions must be issued in sequence. Any other commands other than “Reset (99h)” after the “Enable Reset (66h)” command will disable the “Reset Enable” state. A new sequence of “Enable Reset (66h)” and “Reset (99h)” is needed to reset the device. Once the Reset command is accepted by the device, the device will take approximately  $t_{RST}=30\mu s$  to reset. During this period, no command will be accepted.

Data corruption may happen if there is an on-going or suspended internal Erase or Program operation when Reset command sequence is accepted by the device. It is recommended to check the BUSY bit and the SUS bit in Status Register before issuing the Reset command sequence.

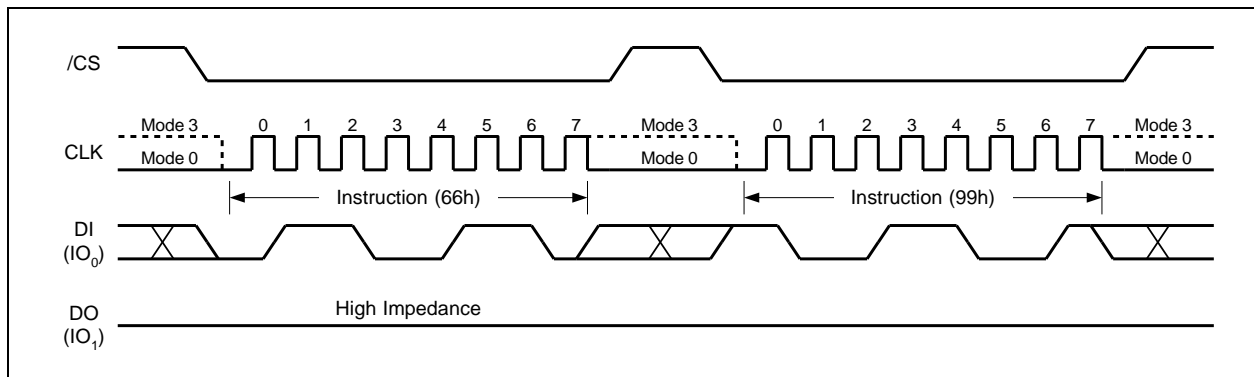

Figure 42. Enable Reset and Reset Instruction Sequence



### 8.2.38 Write Root Key Register (9Bh + 00h)

This command is used by the SPI Flash Controller to initialize the Root Key Register corresponding to the received Counter Address with the received Root Key. It is expected to be used in an OEM manufacturing environment when the SPI Flash Controller and SPI Flash are powered together for the first time.

After the command is issued on the interface the SPI Flash device must ensure that the received transaction is error free. This includes checking following conditions:

- Payload size is correct. (including OP1 is 64 bytes)
- Counter Address falls within the range of supported counters.
- The Root Key Register corresponding to the requested Counter Address was previously uninitialized. [Root\_Key\_Reg\_Init\_State[Counter\_Address] = 0xFFh]
- Truncated signature field is the same as least significant 224 bits of HMAC-SHA-256 based signature computed based on received input parameters.

If the received transaction is error free SPI Flash device successfully executes the command and posts “successful completion” in the RPMC Status Register. This command must be executed to ensure that power cycling in the middle of command execution is properly handled. This requires that the internal state tracking the root key register initialization is written as the last operation of the command execution. (Root\_Key\_Reg\_Init\_State[Counter\_Address] = 0)

Root Key Register Write with root key is = 256'hFF...FF is used as a temporary key. When this request is received error-free Root\_Key\_Reg\_Init\_State[Counter\_Address] is not affected. Instead only the corresponding Monotonic Counter is initialized to 0 if previously uninitialized. This state is tracked as separate state using MC\_Init\_State[Counter\_Address]. This state is used to leave the monotonic counters at the current value when an error free Root Key Register Write operation is received. (Both 256'hFF..FF and non 256'hFF..FF)

Once this command is successfully executed with a non 256'hFF..FF Root Key, the device will not accept the “Write Root Key Register” command any more, and the Root Key value cannot be read out by any instructions.

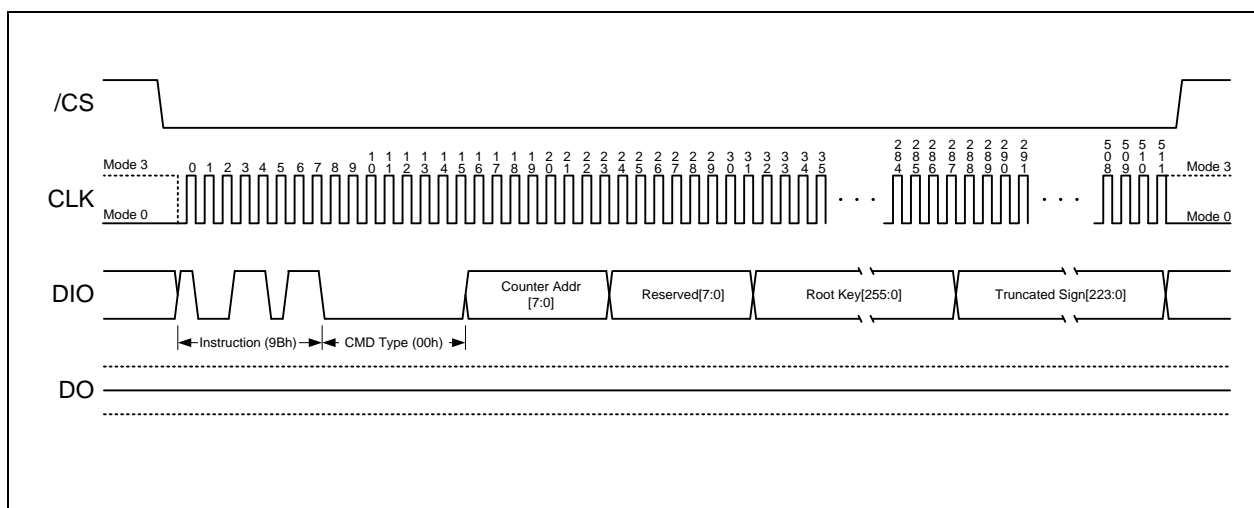

Figure 43. Write Root Key Register Instruction



### 8.2.39 Update HMAC Key (9Bh + 01h)

This command is used by the SPI Flash Controller to update the HMAC-Key register corresponding to the received Counter Address with a new HMAC key calculated based on received input. This command must be issued once only on every power cycle event on the interface. This allows the HMAC key storage to be implemented using volatile memory. Status register busy indication is expected to indicate busy for double the amount of Read\_Counter\_Polling\_Delay specified in SFDP table since this command performs two distinct HMAC-SHA-256 computations.

After the command is issued on the interface the SPI Flash device must ensure that the received transaction is error free. This includes checking following conditions:

- Payload size is correct. (including OP1 = 40 bytes)
- Counter Address falls within the range of supported counters.
- The Monotonic Counter corresponding to the requested Counter Address was previously initialized.
- Signature matches the HMAC-SHA-256 based signature computed based on received input parameters. This command performs two HMAC-SHA-256 operations.

If the received transaction is error free, the SPI Flash device successfully executes the command and posts “successful completion” in the RPMC Status Register.

If the received transaction has errors, the SPI Flash device does not execute the transaction and posts the corresponding error in the RPMC Status Register.

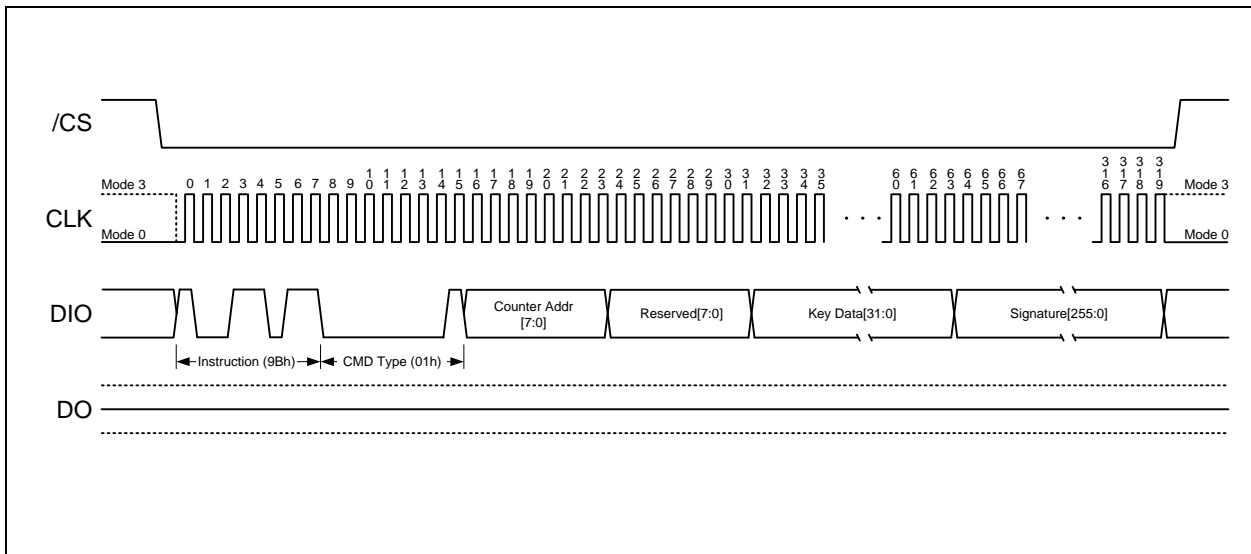

Figure 44. Update HMAC Key Register Instruction



### 8.2.40 Increment Monotonic Counter (9Bh + 02h)

This command is used by the SPI Flash Controller to increment the Monotonic counter by 1 inside the SPI Flash Device.

After the command is issued on the interface the SPI Flash device must ensure that the received transaction is error free. This includes checking following conditions:

- Payload size is correct. (including OP1 = 40 bytes)
- Counter Address falls within the range of supported counters.
- The Monotonic Counter corresponding to the requested Counter Address was previously initialized.
- The HMAC Key Register corresponding to the requested Counter Address was previously initialized.
- The requested Signature matches the HMAC-SHA-256 based signature computed based on received input parameters.
- The received Counter Data matches the current value of the counter read from the SPI Flash.

If the received transaction is error free, the SPI Flash device successfully executes the command and posts "successful completion" in the RPMC Status Register. The increment counter implementation should make sure that the counter increment operation is performed in a power glitch aware manner.

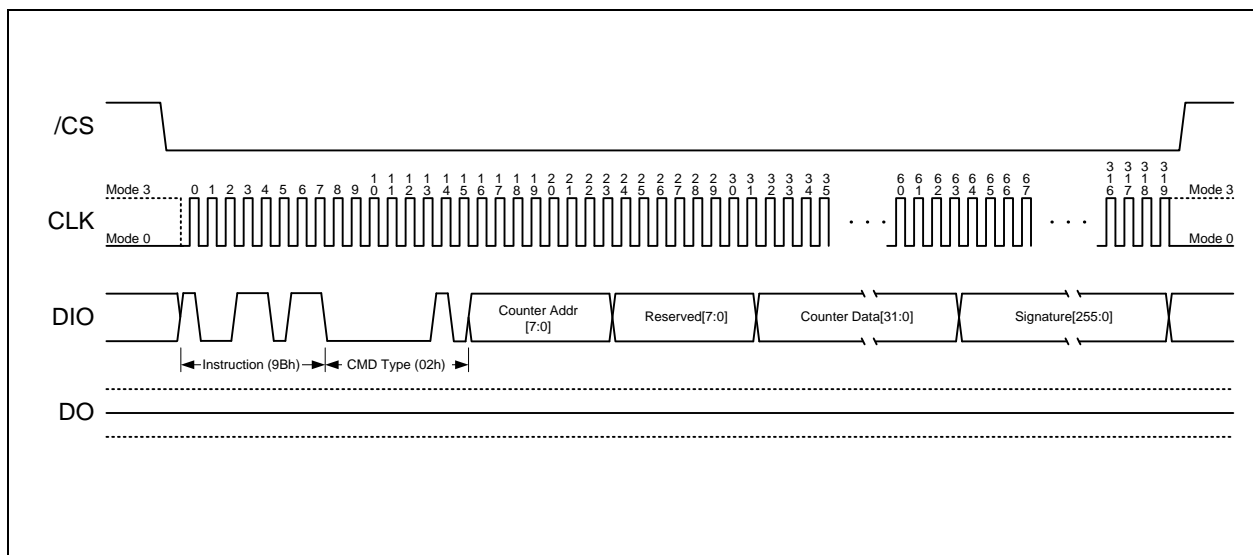

Figure 45. Increment Monotonic Counter Instruction



**8.2.41 Request Monotonic Counter (9Bh + 03h)**

This command is used by the SPI Flash Controller to request the Monotonic counter value inside the SPI Flash Device.

After the command is issued on the interface the SPI Flash device must ensure that the received transaction is error free. This includes checking following conditions:

- Payload size is correct. (including OP1 = 48 bytes)
- Counter Address falls within the range of supported counters.
- The Monotonic Counter corresponding to the requested Counter Address was previously initialized.
- The HMAC Key Register corresponding to the requested Counter Address was previously initialized.
- The requested Signature matches the HMAC-SHA-256 based signature computed based on received input parameters.

If the received transaction is error free, the SPI Flash device successfully executes the command and posts “successful completion” in the RPMC Status Register. In response to this command, the SPI flash reads the monotonic counter addressed by counter address. It calculates HMAC-SHA-256 signatures the second time, based on following parameters.

- HMAC Message[127:0] = Tag [95:0], Counter\_Data\_Read[31:0]
- HMAC Key[255:0] = HMAC\_Key\_Register[Counter\_Address][255:0]

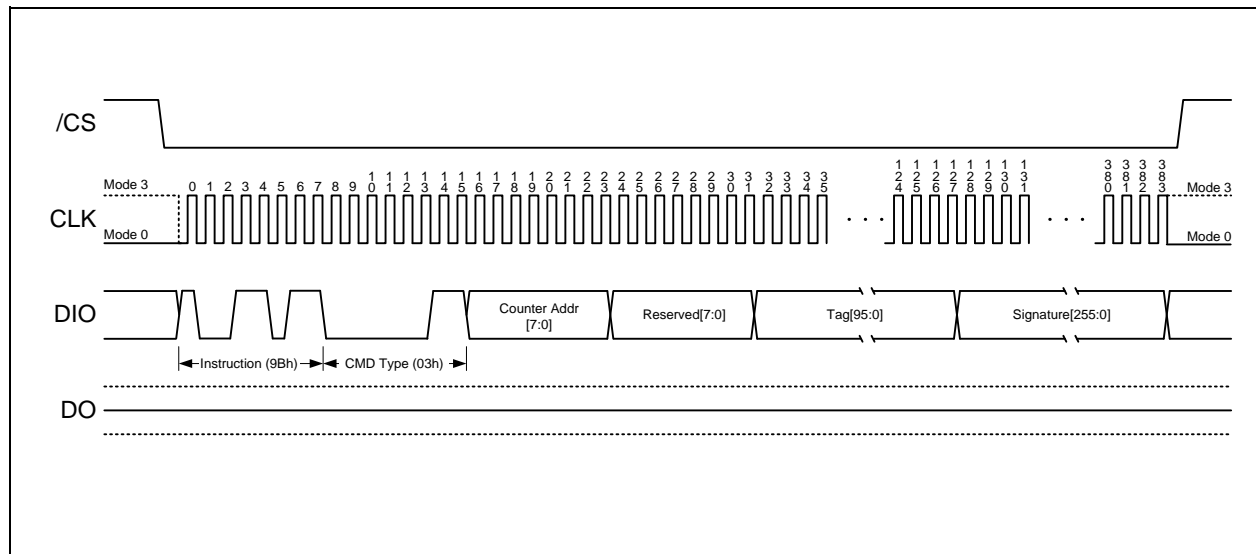

Figure 46. Request Monotonic Counter Instruction

**8.2.42 Reserved RPMC Commands (9Bh + 04h~FFh)**

If the SPI Flash Controller issues any of the reserved command-types, the SPI Flash Device must return Error status in the RPMC Status Register. It asserts bit 2 to indicate that a reserved command-type was issued.



8.2.43 Read RPMC Status / Data (96h)

This command is used by the SPI Flash Controller to read the RPMC status from any previously issued OP1 command. In addition, if previous OP1 command is Request Monotonic Counter and if SPI Flash returns successful completion (BUSY=0) in the RPMC Status Register, then it must also return valid values in the Tag, Counter Data and Signature field. If there're other error flags, the values returned in Tag, Counter and Signature field are invalid. The controller may abort the read prematurely prior to completely reading the entire payload. This may occur when the controller wants to simply read the RPMC status or when it observes an error being returned in the RPMC status field. The controller may also continue reading past the defined payload size of 49 bytes. Since this is an error condition, the SPI Flash may return any data past the defined payload size. The controller must ignore the data.

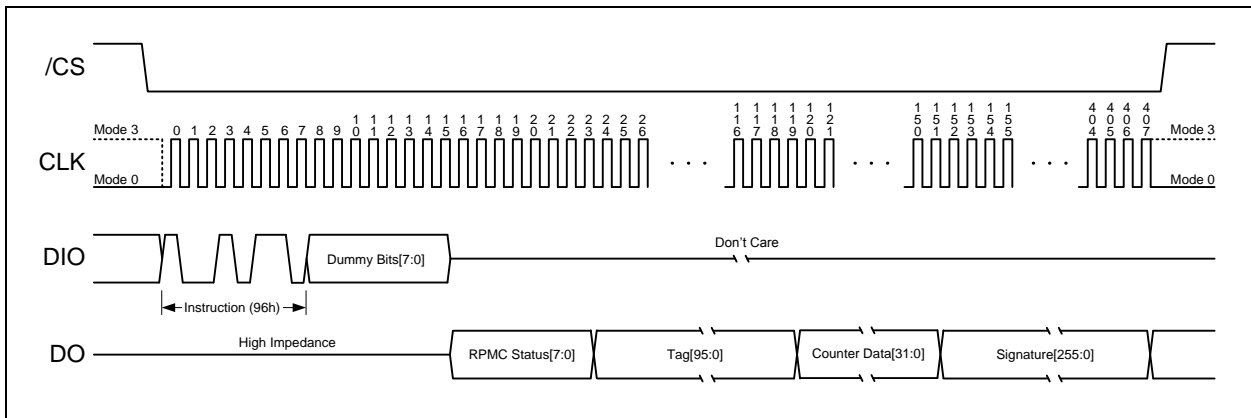

Figure 47a. Read RPMC Data Instruction (BUSY=0)

When BUSY=1, from Byte-3 and beyond, the device will output the RPMC\_Status[7:0] value continuously until /CS terminates the instruction. The device will not output Tag, CounterData & Signature fields when BUSY=1. Once BUSY becomes 0, another OP2 command must be issued to read out the correct Tag, CounterData & Signature fields.

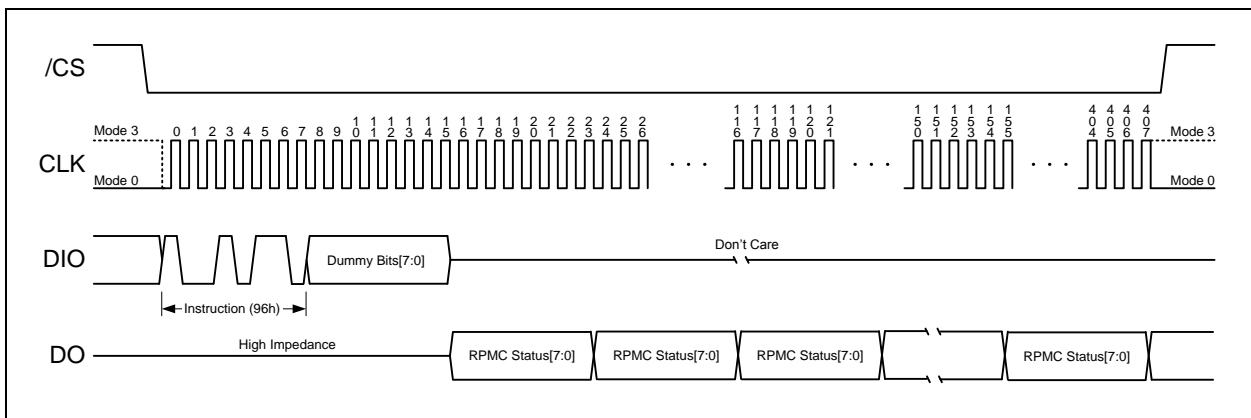

Figure 47b. Read RPMC Data Instruction (BUSY=1)





## 9. ELECTRICAL CHARACTERISTICS

### 9.1 Absolute Maximum Ratings <sup>(1)</sup>

PARAMETERS	SYMBOL	CONDITIONS	RANGE	UNIT
Supply Voltage	VCC		-0.6 to VCC+4.6	V
Voltage Applied to Any Pin	VIO	Relative to Ground	-0.6 to VCC+0.4	V
Transient Voltage on any Pin	V <sub>IOT</sub>	<20nS Transient Relative to Ground	-2.0V to VCC+2.0V	V
Storage Temperature	TSTG		-65 to +150	°C
Lead Temperature	TLEAD		See Note <sup>(2)</sup>	°C
Electrostatic Discharge Voltage	VESD	Human Body Model <sup>(3)</sup>	-2000 to +2000	V

#### Notes:

1. This device has been designed and tested for the specified operation ranges. Proper operation outside of these levels is not guaranteed. Exposure to absolute maximum ratings may affect device reliability. Exposure beyond absolute maximum ratings may cause permanent damage.
2. Compliant with JEDEC Standard J-STD-20C for small body Sn-Pb or Pb-free (Green) assembly and the European directive on restrictions on hazardous substances (RoHS) 2002/95/EU.
3. JEDEC Std JESD22-A114A (C1=100pF, R1=1500 ohms, R2=500 ohms).

### 9.2 Operating Ranges

PARAMETER	SYMBOL	CONDITIONS	SPEC		UNIT
			MIN	MAX	
Supply Voltage <sup>(1)</sup>	VCC	F <sub>R</sub> = 133MHz, f <sub>R</sub> = 50MHz	3.0	3.6	V
		F <sub>R</sub> = 104MHz, f <sub>R</sub> = 50MHz	2.7	3.0	V
		F <sub>R</sub> = 80MHz, RPMC Counters	2.7	3.6	
Ambient Temperature, Operating	T <sub>A</sub>	Industrial	-40	+85	°C

#### Note:

- 1.VCC voltage during Read can operate across the min and max range but should not exceed ±10% of the programming (erase/write) voltage.



### 9.3 Power-Up Power-Down Timing and Requirements

PARAMETER	SYMBOL	SPEC		UNIT
		MIN	MAX	
VCC (min) to /CS Low	tVSL <sup>(1)</sup>	20		μs
Time Delay Before Write Instruction	tPUW <sup>(1)</sup>	5		ms
Write Inhibit Threshold Voltage	VWI <sup>(1)</sup>	1.0	2.0	V

#### Note:

1. These parameters are characterized only.

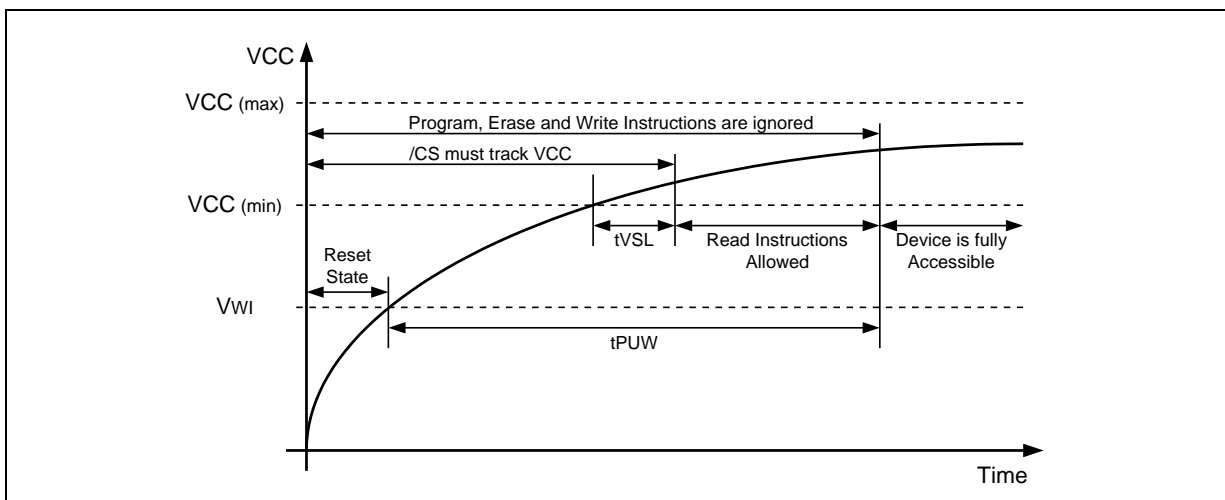

Figure 48a. Power-up Timing and Voltage Levels

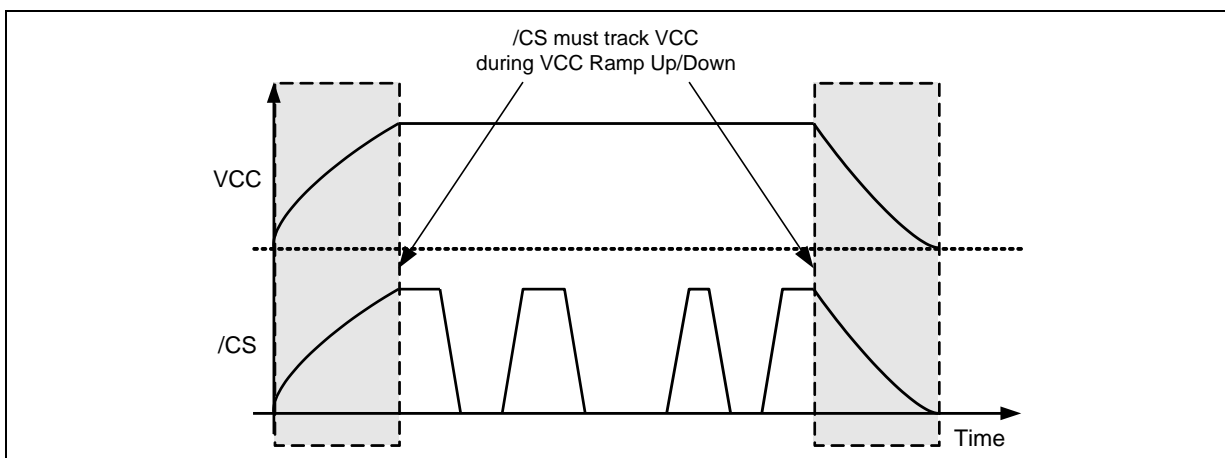

Figure 48b. Power-up, Power-Down Requirement



#### 9.4 DC Electrical Characteristics<sup>(1)</sup>

PARAMETER	SYMBOL	CONDITIONS	SPEC			UNIT
			MIN	TYP	MAX	
Input Capacitance	C <sub>IN</sub>	V <sub>IN</sub> = 0V			12	pF
Output Capacitance	C <sub>OUT</sub>	V <sub>OUT</sub> = 0V			16	pF
Input Leakage	I <sub>LI</sub>				±4	μA
I/O Leakage	I <sub>LO</sub>				±4	μA
Standby Current	I <sub>CC1</sub>	/CS = VCC, V <sub>IN</sub> = GND or VCC		35	100	μA
Power-down Current	I <sub>CC2</sub>	/CS = VCC, V <sub>IN</sub> = GND or VCC		2	25	μA
Current Read Data / Dual /Quad 50MHz <sup>(2)</sup>	I <sub>CC3</sub>	C = 0.1 VCC / 0.9 VCC DO = Open			15	mA
Current Read Data / Dual /Quad 80MHz <sup>(2)</sup>	I <sub>CC3</sub>	C = 0.1 VCC / 0.9 VCC DO = Open			18	mA
Current Read Data / Dual Output Read/Quad Output Read 104MHz <sup>(2)</sup>	I <sub>CC3</sub>	C = 0.1 VCC / 0.9 VCC DO = Open			20	mA
Current Write Status Register	I <sub>CC4</sub>	/CS = VCC		20	25	mA
Current Page Program	I <sub>CC5</sub>	/CS = VCC		20	25	mA
Current Sector/Block Erase	I <sub>CC6</sub>	/CS = VCC		20	25	mA
Current Chip Erase	I <sub>CC7</sub>	/CS = VCC		20	25	mA
RPMC OP1 Write Only	I <sub>CC8</sub>	/CS = VCC		15	20	mA
RPMC OP1 & Array Read	I <sub>CC9</sub>	C = 0.1 VCC / 0.9 VCC DO = Open		19	40	mA
RPMC OP1 & Array Program/Erase	I <sub>CC10</sub>	/CS = VCC		35	45	mA
RPMC OP2 Read Only	I <sub>CC11</sub>	C = 0.1 VCC / 0.9 VCC			30	mA
RPMC OP2 & Array Program/Erase	I <sub>CC12</sub>	C = 0.1 VCC / 0.9 VCC		30	45	mA
Input Low Voltage	V <sub>IL</sub>				VCC x 0.3	V
Input High Voltage	V <sub>IH</sub>		VCC x 0.7			V
Output Low Voltage	V <sub>OL</sub>	I <sub>OL</sub> = 100 μA			0.2	V
Output High Voltage	V <sub>OH</sub>	I <sub>OH</sub> = -100 μA	VCC - 0.2			V

**Notes:**

1. Tested on sample basis and specified through design and characterization data. TA = 25° C, VCC = 3.0V.
2. Checker Board Pattern.



## 9.5 AC Measurement Conditions

PARAMETER	SYMBOL	SPEC		UNIT
		MIN	MAX	
Load Capacitance	CL		30	pF
Input Rise and Fall Times	TR, TF		5	ns
Input Pulse Voltages	VIN	0.1 VCC to 0.9 VCC		V
Input Timing Reference Voltages	IN	0.3 VCC to 0.7 VCC		V
Output Timing Reference Voltages	OUT	0.5 VCC to 0.5 VCC		V

### Note:

1. Output Hi-Z is defined as the point where data out is no longer driven.

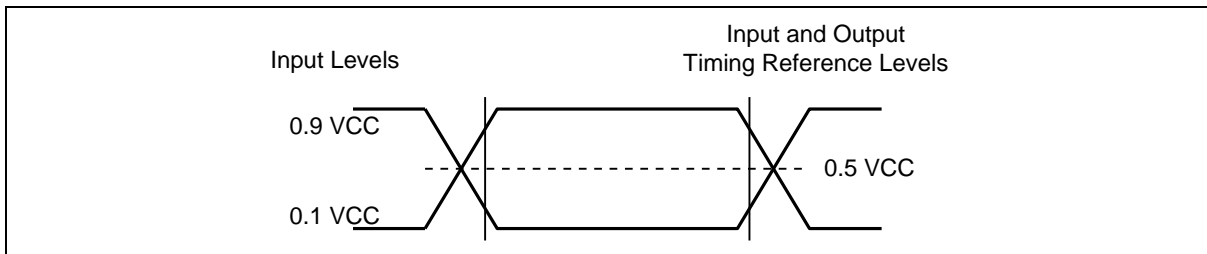

Figure 49. AC Measurement I/O Waveform

9.6 AC Electrical Characteristics<sup>(5)</sup>

DESCRIPTION	SYMBOL	ALT	SPEC			UNIT
			MIN	TYP	MAX	
Clock frequency for Read Data instruction (03h)	f <sub>R</sub>		D.C.		50	MHz
Clock frequency for all other SPI instructions (2.7V-3.0V)	F <sub>R</sub>	f <sub>c1</sub>	D.C.		104	MHz
Clock frequency for all other SPI instructions (3.0-3.6V)	F <sub>R</sub>	f <sub>c1</sub>	D.C.		133	MHz
Clock frequency for RPMC instructions	FR	f <sub>c2</sub>	D.C.		80	MHz
Clock High, Low Time for all SPI instructions except for Read Data (03h)	t <sub>CLH</sub> , t <sub>CLL</sub> <sup>(1)</sup>		3.4			ns
Clock High, Low Time for all RPMC instructions	t <sub>CLH</sub> , t <sub>CLL</sub> <sup>(1)</sup>		5			ns
Clock High, Low Time for Read Data (03h) instruction	t <sub>CRLH</sub> , t <sub>CRLL</sub> <sup>(1)</sup>		8			ns
Clock Rise Time peak to peak	t <sub>CLCH</sub> <sup>(2)</sup>		0.1			V/ns
Clock Fall Time peak to peak	t <sub>CHCL</sub> <sup>(2)</sup>		0.1			V/ns
/CS Active Setup Time relative to CLK	t <sub>SLCH</sub>	t <sub>CSS</sub>	5			ns
/CS Not Active Hold Time relative to CLK	t <sub>CHSL</sub>		5			ns
Data In Setup Time	t <sub>DVCH</sub>	t <sub>DSU</sub>	2			ns
Data In Hold Time	t <sub>CHDX1</sub>	t <sub>DH1</sub>	3			ns
Data In Hold Time for RPMC	t <sub>CHDX2</sub>	t <sub>DH2</sub>	5			ns
/CS Active Hold Time relative to CLK	t <sub>CHSH</sub>		3			ns
/CS Not Active Setup Time relative to CLK	t <sub>SHCH</sub>		3			ns
/CS Deselect Time for Memory Array Read → Memory Array Read	t <sub>SHSL1</sub>	t <sub>CSH</sub>	10			ns
/CS Deselect Time for Erase or Program → Read Status Registers or RPMC operation → RPMC operation	t <sub>SHSL2</sub>	t <sub>CSH</sub>	50			ns
Output Disable Time / Output Disable Time (RPMC)	t <sub>SHQZ</sub>	t <sub>DIS</sub>			7 / 8.5	ns
Clock Low to Output Valid 2.7V-3.0V / 3.0V-3.6V	t <sub>CLQV1</sub>	t <sub>V1</sub>			7 / 6	ns
Clock Low to Output Valid(Non-array Read & RPMC OP2) 2.7V-3.0V / 3.0V-3.6V	t <sub>CLQV2</sub>	t <sub>V2</sub>			8.5 / 7.5	ns

Continued – next page



## 9.7 AC Electrical Characteristics (cont'd)

DESCRIPTION	SYMBOL	ALT	SPEC			UNIT
			MIN	TYP	MAX	
Output Hold Time	tCLQX	tHO	2			ns
/CS High to Power-down Mode	tDP <sup>(2)</sup>				3	μs
/CS High to Standby Mode without ID Read	tRES1 <sup>(2)</sup>				3	μs
/CS High to Standby Mode with ID Read	tRES2 <sup>(2)</sup>				1.8	μs
/CS High to next Instruction after Suspend	tsUS <sup>(2)</sup>				20	μs
/CS High to next Instruction after Reset	trST <sup>(2)</sup>				30	μs
RPMC Write Root Key Register	tKEY			170	250	μs
RPMC Update HMAC Key Register	tHMAC			50	75	μs
RPMC Increment Monotonic Counter	tINC1			80	200	μs
RPMC Increment Monotonic Counter (Counter Switching)	tINC2			75	250	ms
RPMC Request Monotonic Counter	tREQ			80	120	μs
/RESET pin Low period to reset the device	tRESET <sup>(2)</sup>		1 <sup>(4)</sup>			μs
Write Status Register Time	tW			10	15	ms
Write Status Register Time (Volatile Status Register)	tW			50		ns
Page Program Time	tPP			0.7	3	ms
Sector Erase Time (4KB)	tSE			45	400	ms
Block Erase Time (32KB)	tBE <sub>1</sub>			120	1,600	ms
Block Erase Time (64KB)	tBE <sub>2</sub>			150	2,000	ms
Chip Erase Time	tCE			40	200	s

**Notes:**

1. Clock high + Clock low must be less than or equal to 1/fc.
2. Value guaranteed by design and/or characterization, not 100% tested in production.
3. For multiple bytes after first byte within a page,  $t_{BPn} = t_{BP1} + t_{BP2} * N$  (typical) and  $t_{BPn} = t_{BP1} + t_{BP2} * N$  (max), where N = number of bytes programmed.
4. It is possible to reset the device with shorter tRESET (as short as a few hundred ns), a 1us minimum is recommended to ensure reliable operation.
5. Tested on sample basis and specified through design and characterization data. TA = 25° C, VCC = 3.0V, 25% driver strength.



**9.8 Serial Output Timing**

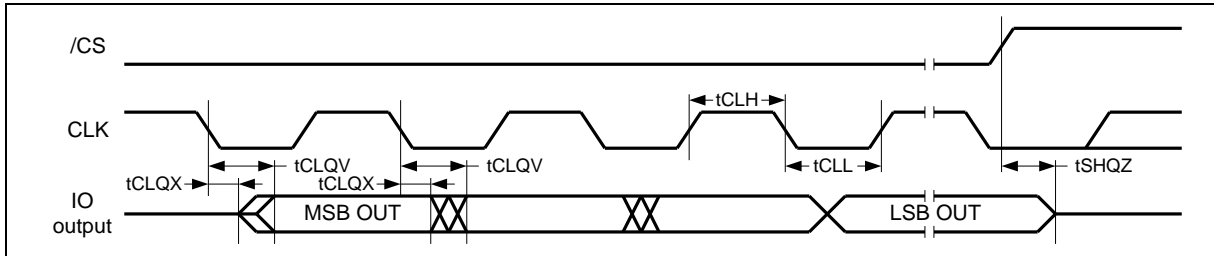

**9.9 Serial Input Timing**

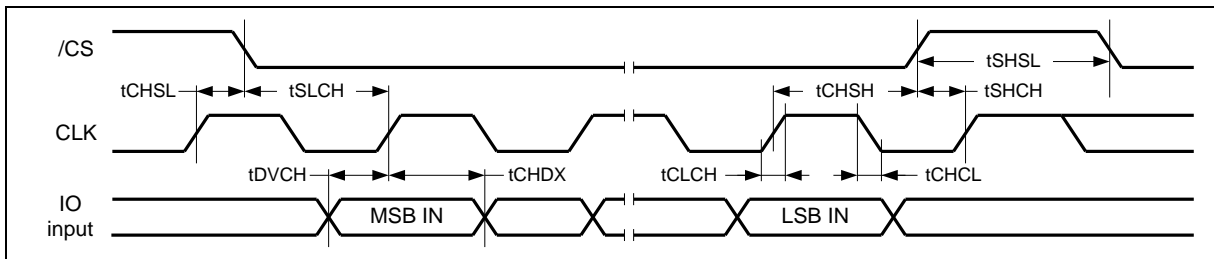



10. PACKAGE SPECIFICATIONS

10.1 8-Pin SOIC 208-mil (Package Code S)

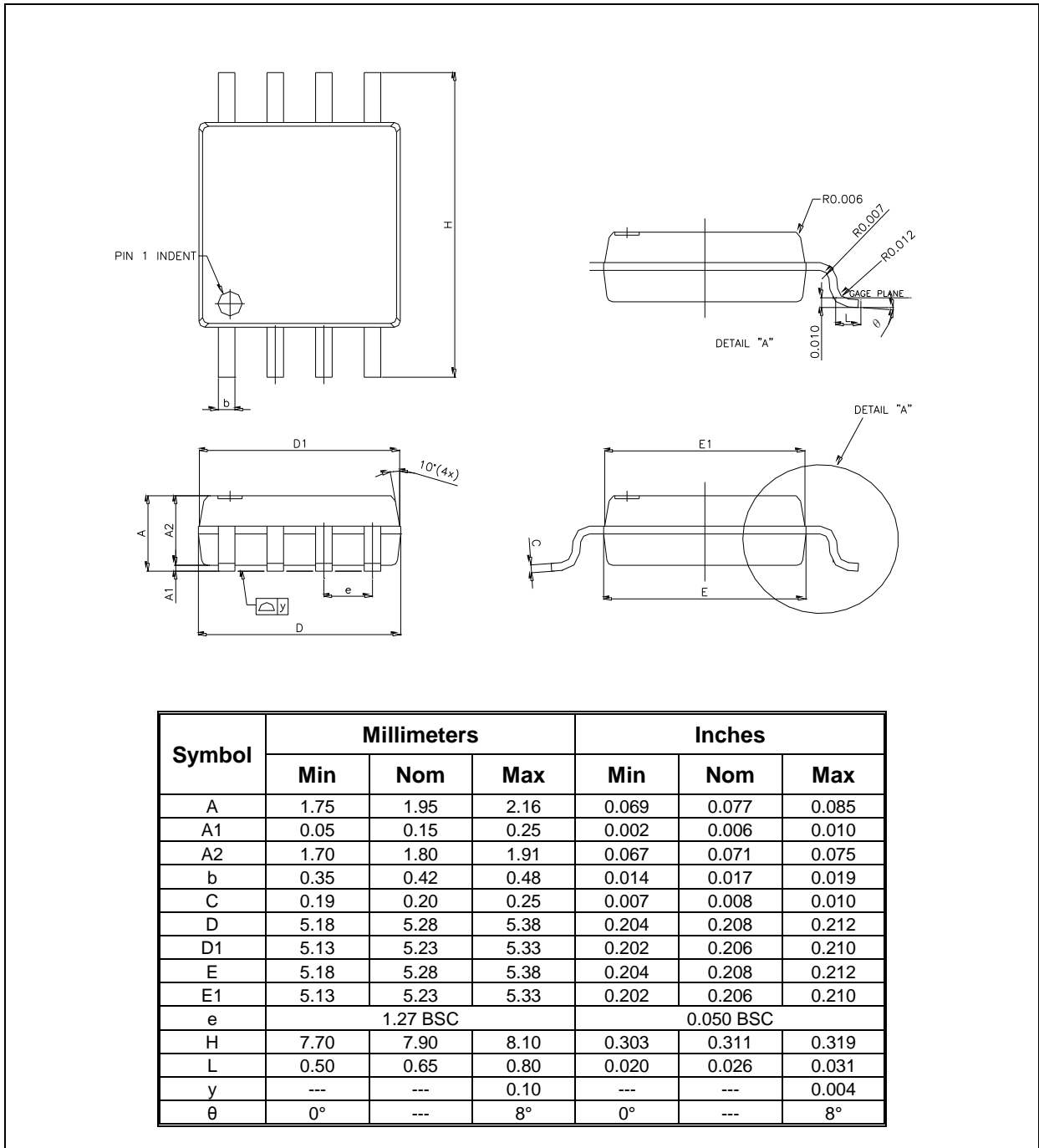





10.2 8-Pad WSON 6x5-mm (Package Code P)

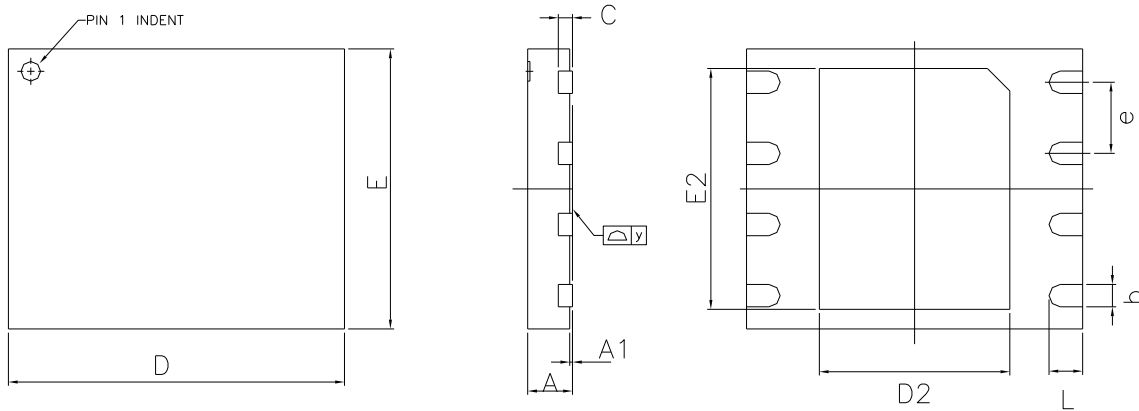

Symbol	Millimeters			Inches		
	Min	Nom	Max	Min	Nom	Max
A	0.70	0.75	0.80	0.028	0.030	0.031
A1	0.00	0.02	0.05	0.000	0.001	0.002
b	0.35	0.40	0.48	0.014	0.016	0.019
C	---	0.20 REF	---	---	0.008 REF	---
D	5.90	6.00	6.10	0.232	0.236	0.240
D2	3.35	3.40	3.45	0.132	0.134	0.136
E	4.90	5.00	5.10	0.193	0.197	0.201
E2	4.25	4.30	4.35	0.167	0.169	0.171
e	1.27 BSC			0.050 BSC		
L	0.55	0.60	0.65	0.022	0.024	0.026
y	0.00	---	0.075	0.000	---	0.003



### 10.3 8-Pad WSON 8x6-mm (Package Code E)

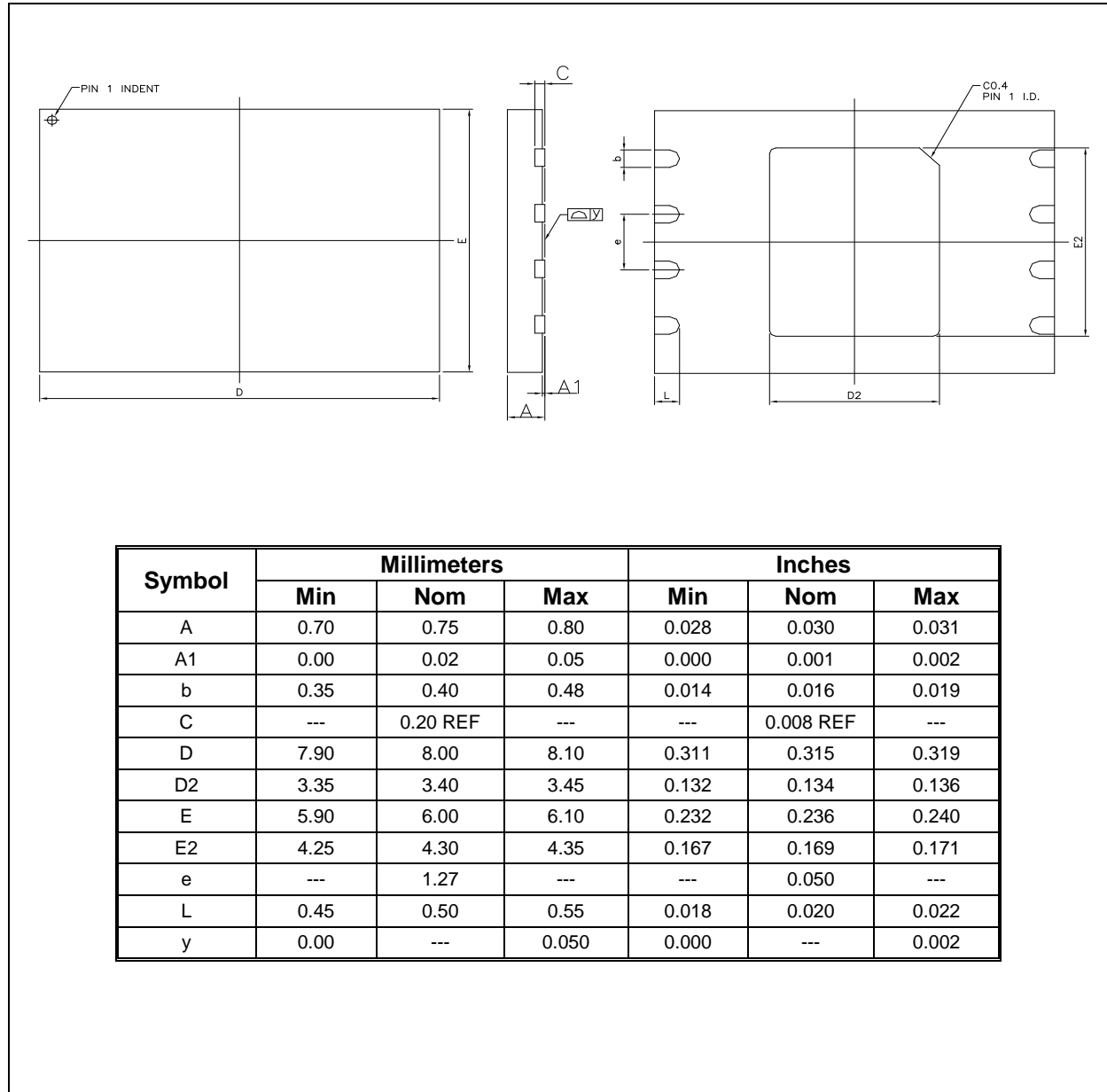

**Note:**

The metal pad area on the bottom center of the package is not connected to any internal electrical signals. It can be left floating or connected to the device ground (GND pin). Avoid placement of exposed PCB vias under the pad.



10.4 Ordering Information

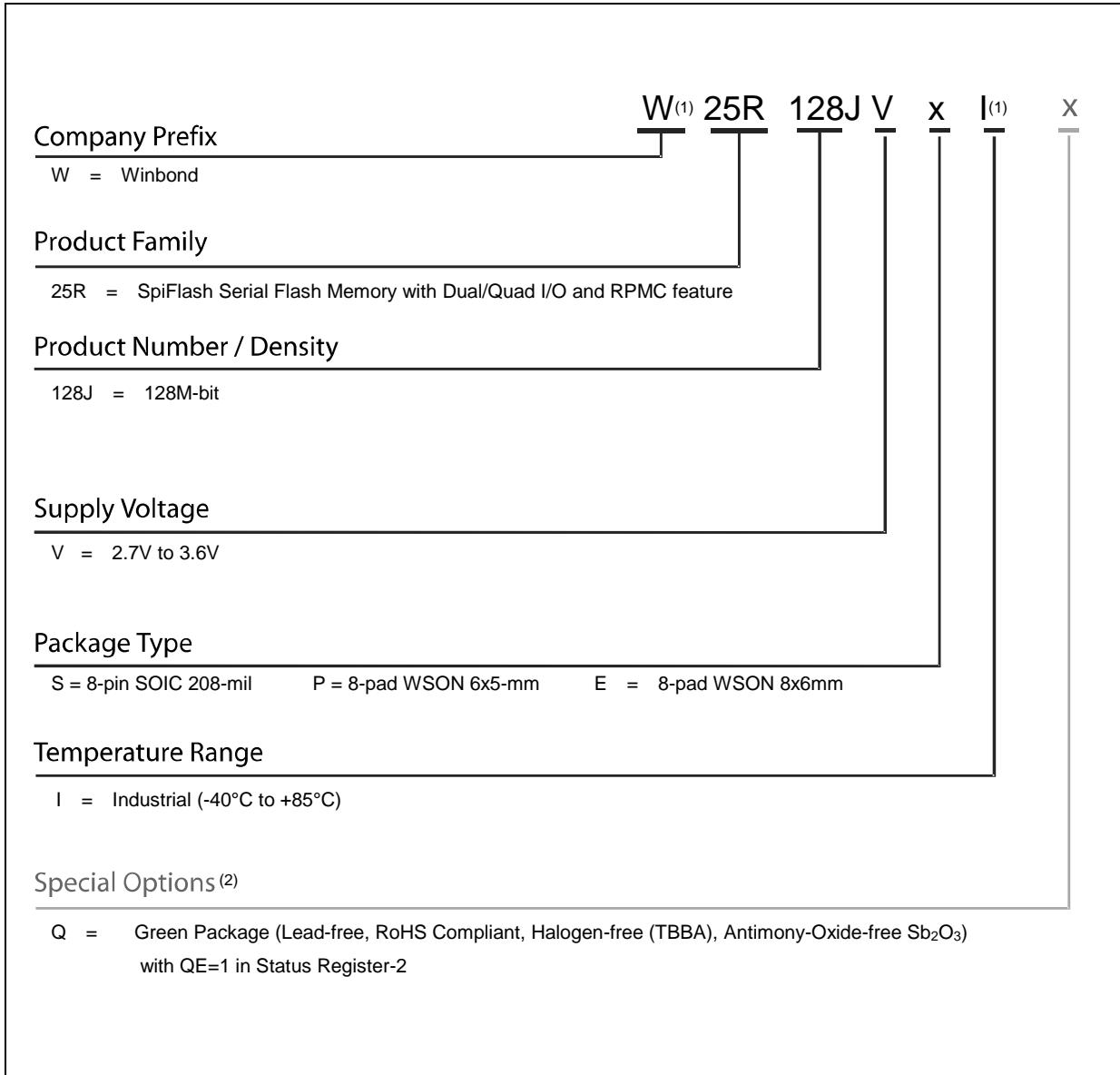

Notes:

1. The "W" prefix and the Temperature designator "I" are not included on the part marking.
2. Standard bulk shipments are in Tube (shape E). Please specify alternate packing method, such as Tape and Reel (shape T) or Tray (shape S), when placing orders.

## W25R128JV



### 10.5 Valid Part Numbers and Top Side Marking

The following table provides the valid part numbers for the W25R128JV SpiFlash Memory. Please contact Winbond for specific availability by density and package type. Winbond SpiFlash memories use a 12-digit Product Number for ordering. However, due to limited space, the Top Side Marking on all packages uses an abbreviated 10-digit number.

<b>PACKAGE TYPE</b>	<b>DENSITY</b>	<b>PRODUCT NUMBER</b>	<b>TOP SIDE MARKING</b>
<b>S</b> SOIC-8 208-mil	128M-bit	W25R128JVSIQ	25R128JVSQ
<b>P</b> WSO8-8 6x5-mm	128M-bit	W25R128JVPIQ	25R128JVPQ
<b>E</b> WSO8-8 8x6mm	128M-bit	W25R128JVEIQ	25R128JVEQ

**Note:**

1. Not all package options are available readily, please contact Winbond for availability.



## 11. REVISION HISTORY

VERSION	DATE	PAGE	DESCRIPTION
A	08/07/2017 03/28/2018		New Create Preliminary Added WSON 6x5 information
B	09/03/2018	16 5,73-75	Removed Preliminary Updated DRV default value Added WSON 8x6 information

### Trademarks

*Winbond* and *SpiFlash* are trademarks of *Winbond Electronics Corporation*. All other marks are the property of their respective owner.

### Important Notice

*Winbond* products are not designed, intended, authorized or warranted for use as components in systems or equipment intended for surgical implantation, atomic energy control instruments, airplane or spaceship instruments, transportation instruments, traffic signal instruments, combustion control instruments, or for other applications intended to support or sustain life. Furthermore, *Winbond* products are not intended for applications wherein failure of *Winbond* products could result or lead to a situation wherein personal injury, death or severe property or environmental damage could occur. *Winbond* customers using or selling these products for use in such applications do so at their own risk and agree to fully indemnify *Winbond* for any damages resulting from such improper use or sales.

**Information in this document is provided solely in connection with Winbond products. Winbond reserves the right to make changes, corrections, modifications or improvements to this document and the products and services described herein at any time, without notice.**

---

Please note that all data and specifications are subject to change without notice.  
All the trademarks of products and companies mentioned in this datasheet belong to their respective owners.



Компания «ЭлектроПласт» предлагает заключение долгосрочных отношений при поставках импортных электронных компонентов на взаимовыгодных условиях!

Наши преимущества:

- Оперативные поставки широкого спектра электронных компонентов отечественного и импортного производства напрямую от производителей и с крупнейших мировых складов;
- Поставка более 17-ти миллионов наименований электронных компонентов;
- Поставка сложных, дефицитных, либо снятых с производства позиций;
- Оперативные сроки поставки под заказ (от 5 рабочих дней);
- Экспресс доставка в любую точку России;
- Техническая поддержка проекта, помощь в подборе аналогов, поставка прототипов;
- Система менеджмента качества сертифицирована по Международному стандарту ISO 9001;
- Лицензия ФСБ на осуществление работ с использованием сведений, составляющих государственную тайну;
- Поставка специализированных компонентов (Xilinx, Altera, Analog Devices, Intersil, Interpoint, Microsemi, Aeroflex, Peregrine, Syfer, Eurofarad, Texas Instrument, Miteq, Cobham, E2V, MA-COM, Hittite, Mini-Circuits, General Dynamics и др.);

Помимо этого, одним из направлений компании «ЭлектроПласт» является направление «Источники питания». Мы предлагаем Вам помощь Конструкторского отдела:

- Подбор оптимального решения, техническое обоснование при выборе компонента;
- Подбор аналогов;
- Консультации по применению компонента;
- Поставка образцов и прототипов;
- Техническая поддержка проекта;
- Защита от снятия компонента с производства.



#### Как с нами связаться

**Телефон:** 8 (812) 309 58 32 (многоканальный)

**Факс:** 8 (812) 320-02-42

**Электронная почта:** [org@eplast1.ru](mailto:org@eplast1.ru)

**Адрес:** 198099, г. Санкт-Петербург, ул. Калинина, дом 2, корпус 4, литера А.