

SKYEMODULE M2 DATASHEET

VERSION 140427



COPYRIGHT INFORMATION:

Copyright 2014 SkyeTek, Inc., 1732 Wazee St. Suite 202, Denver, Colorado 80202, U.S.A. All rights reserved.

Version 140427

This product or document is protected by copyright and distributed under licenses restricting its use, copying, distribution, and decompilation. No part of this product or document may be reproduced in any form by any means without prior written authorization of SkyeTek and its licensors, if any.

SkyeTek and SkyeWare are trademarks or registered trademarks of SkyeTek, Inc.

CryptoRF is a registered trademark of Atmel Corporation.

MIFARE and NXP is a registered trademark of Royal Philips Electronics.

Tag-it is a trademark of Texas Instruments, Incorporated.

MicroSoft and Windows are registered trademarks of Microsoft Corporation.

TECHNICAL SUPPORT AND CONTACT INFORMATION

SkyeTek, Inc.

1732 Wazee Street Suite 202

Denver, CO 80202

<http://www.skyetek.com>

SALES:

sales@skyetek.com

TECHNICAL SUPPORT:

support@skyetek.com



Skyetek Inc
1732 Wazee St. Ste 202
Denver, CO 80202
www.skyetek.com

Main 720.328.3425 Fax:720.228.2400

TABLE OF CONTENTS

1	About this Document	8
1.1	Revision History	8
2	Definition of Terms	9
3	Ordering Information	10
3.1	Part Numbers	10
3.2	How to Buy	11
4	SkyeModule M2 Overview	12
4.1	Features.....	12
4.2	Applications	13
4.3	SkyeWare™ Software	13
5	Mechanical Specifications	14
5.1	MH Variant.....	14
5.2	CF Variant	15
6	Pinning Information	16
6.1	Pin Mapping for the SkyeModule M2-MH.....	16
6.2	Pin Mapping for the SkyeModule M2-CF	17
6.3	Using the GPIO Pins	19
7	Environmental Specifications	20
7.1	Electrostatic Precautions	20
7.2	General Ratings and Operating Conditions	20
8	Electrical Specifications	21
8.1	Absolute Maximum Ratings	21
9	Host Interface Specifications.....	22
9.1	TTL Serial.....	23
9.2	SPI.....	25



Skyetek Inc
 1732 Wazee St. Ste 202
 Denver, CO 80202
www.skyetek.com

9.3 USB 2.0..... 28

9.4 I²C..... 29

10 Radio Specifications 31

10.1 Agency Approvals..... 31

10.2 Frequency Band 31

10.3 Tag Protocols 31

11 SkyeModule M2 Antenna Options 32

12 Communicating with the Module 33

12.1 Host Communication (SkyeTek Protocol v3)..... 33

12.2 Request Formats 33

12.3 Response Formats 34

13 Customizing System Parameters..... 35

13.1 Changing System Parameters 35

13.2 System Parameter Descriptions..... 36

13.2.1 Serial Number..... 36

13.2.2 Firmware Version 36

13.2.3 Hardware Version 37

13.2.4 Product Code 37

13.2.5 Reader ID 37

13.2.6 Reader Name..... 37

13.2.7 Host Interface Type..... 38

13.2.8 Interface Baud Rate 38

13.2.9 User Port Direction 38

13.2.10 User Port Value..... 39

13.2.11 MUX Control..... 39

13.2.12 Operating Mode 39

13.2.13 GPIO Toggle on Select..... 40



Skyetek Inc
 1732 Wazee St. Ste 202
 Denver, CO 80202
www.skyetek.com

14 Operating Modes..... 41



Main 720.328.3425 Fax:720.228.2400

Skyetek Inc
1732 Wazee St. Ste 202
Denver, CO 80202
www.skyetek.com

LIST OF FIGURES

Figure 3-1: SkyeTek Part Number Scheme	10
Figure 4-1: SkyeModule M2-CF	12
Figure 5-1: M2-MH Dimensions	14
Figure 5-2: SkyeModule M2-MH.....	14
Figure 5-3: M2-CF Dimensions	15
Figure 5-4: SkyeModule M2-CF	15
Figure 6-1: M2-MH Pin Numbering	16
Figure 6-2: M2-CF Pin Numbering.....	17
Figure 9-1: TTL Serial Connection Diagram	23
Figure 9-2: TTL Serial Timing Diagram	24
Figure 9-3: SPI Connection Diagram.....	25
Figure 9-4: SPI Request Setup and Sample Timing	26
Figure 9-5: SPI Request Timing	26
Figure 9-6: SPI Response Timing	27
Figure 9-7: USB Connection Diagram.....	28
Figure 9-8: I2C Connection Diagram	29
Figure 9-9: I2C Timing Diagram	30



Skyetek Inc
 1732 Wazee St. Ste 202
 Denver, CO 80202
www.skyetek.com

LIST OF TABLES

Table 1-1: Revision History	8
Table 3-1: Part Number Details	10
Table 3-2: M2 Part Numbers	10
Table 6-1: SkyeModule M2 Connector Specification	16
Table 6-2: SkyeModule M2-MH Pin Descriptions	17
Table 6-3: SkyeModule M2-CF Pin Descriptions	18
Table 7-1: Environmental Ratings/Operating Conditions	20
Table 8-1: SkyeModule M2 Electrical Specifications	21
Table 8-2: Absolute Maximum Ratings/Operating Conditions	22
Table 11-1: Estimated Read Ranges	32
Table 12-1: Request Format (bytes), ASCII Mode	33
Table 12-2: Request Format (bytes), Binary Mode	33
Table 12-3: Response Format (bytes), Binary Mode	34
Table 13-1: SkyeModule M2 System Parameters	35



Skyetek Inc
 1732 Wazee St. Ste 202
 Denver, CO 80202
www.skyetek.com

1 About this Document

This document covers the operating characteristics and modes of the SkyeModule M2. Included in this document are electrical connection diagrams, timing characteristics, electrical and mechanical specifications, system parameters, ordering information, and pin diagrams.

1.1 Revision History

Revision	Author	Change
100212	Ryan Smith	This revision includes updated timing characteristics, electrical connection diagrams, pinning information, ordering information, and mechanical specifications.
122012	Brad Alcorn	Added missing I ² C pins to the MH pin map table.
070313	Brad Alcorn	Corrected the MH pin map table.
041814	Brad Alcorn	Updated part numbers and corrected host interface diagrams to match MH pin mapping.
140427	JRP	Updated logo

Table 1-1: Revision History



2 Definition of Terms

3DES	Triple Data Encryption Standard
AES	Advanced Encryption Standard
API	Application Programming Interface
DES	Data Encryption Standard
GPIO	General Purpose Input/Output
HID	Human Interface Device
HMAC	Hash-based message authentication code
I ² C	Inter-integrated Circuit
LSB	Least Significant Bit
MD5	Message-Digest Algorithm
MSB	Most Significant Bit
NC	No Connect
PRNG	Pseudo-Random Number Generator
RoHS	Reduction of Hazardous Substances
SHA	Secure Hash Algorithm
SPI	Serial Peripheral Interface
SSEL	Slave Select
STP V3	SkyeTek Protocol Version 3
TTL	Transistor-transistor Logic



3 Ordering Information

3.1 Part Numbers

The M2 part number is constructed according to the SkyeTek part number specification below:



Figure 3-1: SkyeTek Part Number Scheme

Details:

Code	Options	Description
Product Family	SM = SkyeModule	Highest level product family code.
Product Type	M2 = M2	Specifies the specific part type.
Build Type	MH = Mounting holes CF = CF Connector	Specifies standard form factors or custom builds.
Options	Blank = Serial, 38400B	This field is left for special customer part numbers or standard variations such I2C for I2C as the default host interface. Consult the SkyeTek sales team for custom orders. NOTE: In developer kits, the module comes programmed to USB.

Table 3-1: Part Number Details

The standard part numbers for the M2 are shown in Table 3-2. Always contact a reseller or the SkyeTek sales team for the latest part number.

Module	Part Number
SkyeModule M2-MH	SM-M2-MH
SkyeModule M2-CF	SM-M2-CF

Table 3-2: M2 Part Numbers



Skyetek Inc
1732 Wazee St. Ste 202
Denver, CO 80202
www.skyetek.com

3.2 How to Buy

SkyeTek products are distributed through a worldwide distribution network as well as directly through SkyeTek. For more information on how to purchase SkyeTek products in your area, please visit the [How To Buy](http://SkyeTek.com/HowToBuy) page on the SkyeTek website at SkyeTek.com/HowToBuy.



Main 720.328.3425 Fax:720.228.2400

Skyetek Inc
1732 Wazee St. Ste 202
Denver, CO 80202
www.skyetek.com

4 SkyeModule M2 Overview

The SkyeModule M2® is a multi-protocol, secure HF (13.56MHz) RFID reader platform that supports a variety of secure HF RFID tags and can provide security for otherwise non-secure RFID tags. The SkyeModule M2 can read and write to transponders based on the ISO14443 (parts 2, 3, and 4) and ISO15693 air interface and communications standards. The SkyeModule M2 also supports standard encryption algorithms (DES, 3DES, and AES), secure hash functions (SHA and MD5), and an internal Pseudo-Random Number Generator (PRNG).

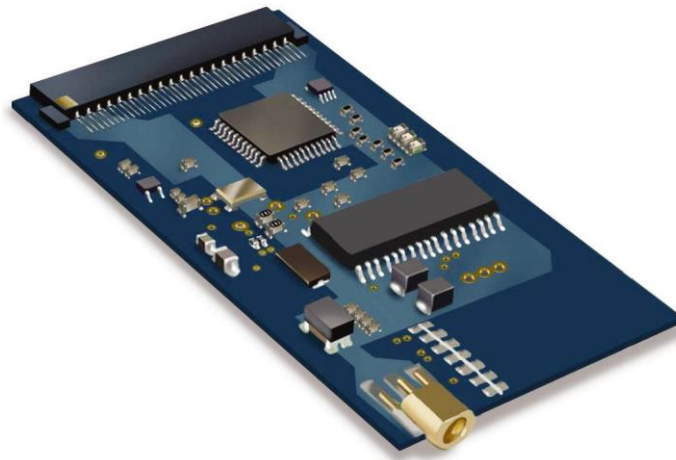

Figure 4-1: SkyeModule M2-CF

4.1 Features

Designed for item-level tagging, consumables, handhelds, and label printers, the SkyeModule M2 offers the following features:

- Common communications protocol— All SkyeTek common blade products use SkyeTek Protocol v3 (STPv3) to drive low level communications. SkyeTek APIs built on top of STPv3 give you methods for exercising readers and reading tags from your custom windows applications.
- A standard 50 ohm antenna output enables use of an external antenna to optimize the read range/rate.
- Multiple communications interfaces: TTL Serial, SPI, I²C, and native USB for connection to a host PC with or without a serial port. These options are software selectable to support both loosely and tightly coupled integrations. The SkyeModule M2 also has up to seven programmable GPIO pins for I/O connections to peripherals.
- Serial data rates are adjustable from 9.6 to 115.2 kbps. Field-upgradable firmware provides forward compatibility for adding future tag protocols, security features, and customized enhancements.



Skyetek Inc
1732 Wazee St. Ste 202
Denver, CO 80202
www.skyetek.com

- GPIO toggle on select tag feature for LED, buzzer or other indicator control.

4.2 Applications

- Product and Consumable Anti-Counterfeiting
- RFID Printers
- Library tracking systems
- Healthcare Patient Identification
- Access control
- Document Tracking
- Loyalty Card Reader
- Ticketing
- Kiosks
- Proximity Sensing

4.3 SkyeWare™ Software

All SkyeModule M2 developer kits ship with the SkyeWare 4 software package for Microsoft® Windows® to aid your RFID development process. This package includes:

- **Capabilities Functions** - This utility offers a quick way to perform high-level demonstrations of the basic functionality of the SkyeModule M2. You can test read range, anti-collision (singulation) capabilities, and use inventory selection and memory functions.
- **Configuration** - You can easily view and change reader configuration parameters, configure tags, and update or change firmware.
- **Protocol Command Builder** - This utility provides a GUI interface for constructing the SkyeTek Protocol v3 commands in either ASCII or binary format, based on tag type and selected flags. You can build and test low-level SkyeTek protocol commands and use all the features of the reader at the protocol level. It is an excellent way to learn more about SkyeTek Protocol v3 commands. For more information, see the [SkyeWare User Guide](#).
- **APIs** - SkyeTek offers C and .NET APIs for Windows so that you can easily create interfaces between your programming language and any SkyeTek reader modules that communicate using SkyeTek Protocol v3. The APIs provide a rich assortment of functions that allows complete access to and manipulation of your SkyeModule M2. For more information, see the [SkyeTek C and .NET API Developer Guide](#).



5 Mechanical Specifications

The SkyeModule M2 has two variants: MH (equipped with mounting holes) and CF (uses compact-flash-style connector). The following sections provide information and mechanical dimensions for each. In addition, 3D models of our modules are available at <http://www.skyetek.com>.

5.1 MH Variant

Dimensions: 53.2 mm x 70.4 mm = 3745.28 mm²

Height: 9mm

Clearance: Approx. 2.5 mm between edge of mounting hole and edge of printed circuit board (PCB) (side-to-side direction)

Weight: 10.5 grams

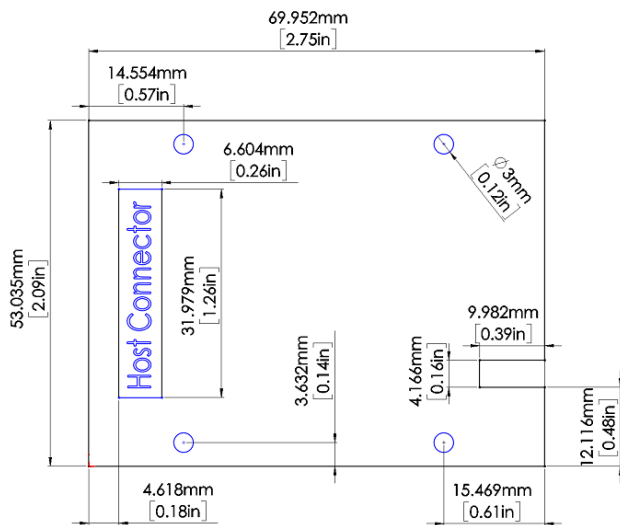

Figure 5-1: M2-MH Dimensions

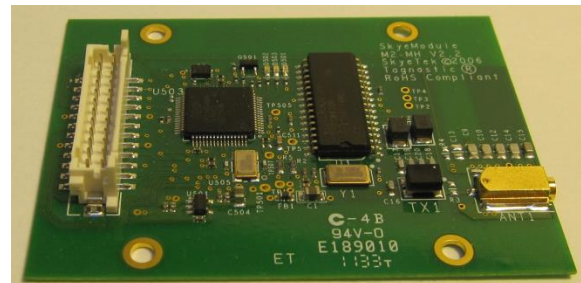

Figure 5-2: SkyeModule M2-MH

5.2 CF Variant

Dimensions: 66.1 mm x 32.5 mm = 2148.25 mm²

Height: 5mm (9mm with ISO 7816 slot)

Weight: 8.6 grams

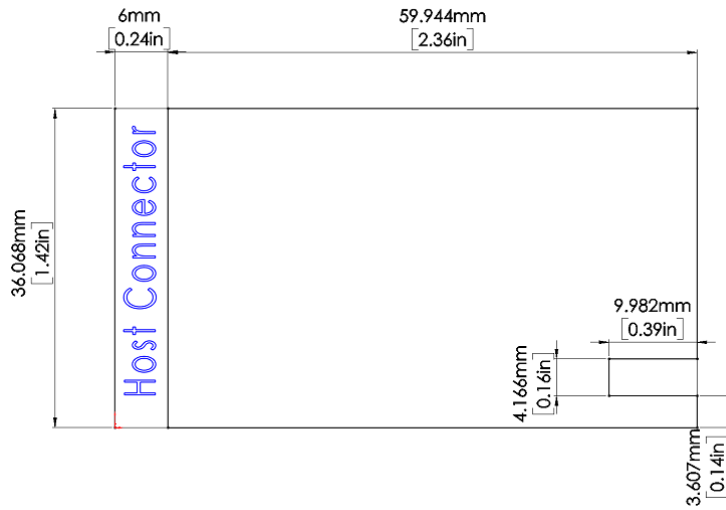

Figure 5-3: M2-CF Dimensions

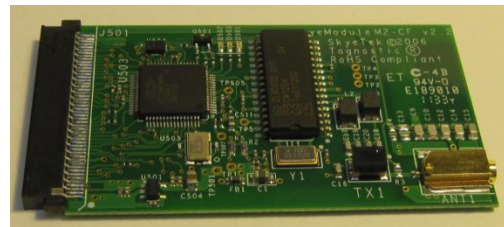

Figure 5-4: SkyeModule M2-CF

6 Pinning Information

SkyeModule Type	Connector Type	Manufacturer	Manufacturer's Part Number
M2-CF	Compact flash type II (receptacle on module)	Molex	67799-0004
	CF counterpart to connect to module	Molex	67155-0002
M2-MH	Surface-mount protected header (receptacle on module)	Hirose	DF11Z-24DP-2V
	MH counterpart to connect to module	Hirose	DF11Z-24DS-2V

Table 6-1: SkyeModule M2 Connector Specification

6.1 Pin Mapping for the SkyeModule M2-MH

The SkyeModule M2-MH host connector is a 24-pin MH male connector as specified in Table 6-1. Figure 6-1 shows the pin-out locations for the SkyeModule M2, and Table 6.2 lists the pin mapping for the SkyeModule M2-MH. (All unconnected pins should be left floating.)

NOTE - The standard Pin 1 indicator does *not* correspond to the actual Pin 1 location on the connector. Pin 1 is located on the same side of the connector as the indicator but on the opposite end of the row of pins.

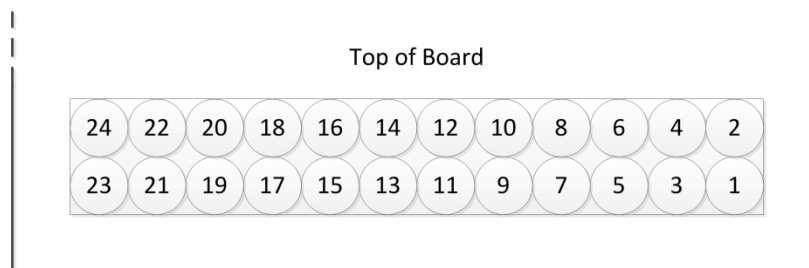

Figure 6-1: M2-MH Pin Numbering

Pin	Name	Description	Pin	Name	Description
1	GPIO0	General-purpose I/O	13	DNEG	USB negative
2	RXD	UART receive	14	SDA	I ² C Data
3	GPIO1	General-purpose I/O	15	VCC	Supply voltage
4	TXD	UART transmit	16	GND	Ground
5	GPIO2	General-purpose I/O	17	NC	Not connected
6	NC	Not connected	18	MISO	SPI master in, slave out
7	GPIO3	General-purpose I/O	19	RESET_N	Active low reset
8	NC	Not connected	20	MOSI	SPI master out, slave in
9	VCC	Supply voltage	21	NC	Reserved
10	GND	Ground	22	SCK	SPI clock in
11	DPOS	USB positive	23	NC	Reserved
12	SCL	I ² C Clock	24	SSEL	SPI slave select

Table 6-2: SkyeModule M2-MH Pin Descriptions



CAUTION - If you perform custom integration work on your SkyeModule M2, make sure that you connect all available power and ground pins. Failure to do so reduces read range and could cause failure of the module. (Pins listed as not connected can be left floating.)

6.2 Pin Mapping for the SkyeModule M2-CF

The SkyeModule M2-CF host connector is a 50-pin CF female connector specified in Table 6-1. Figure 7-2 shows the connector pin-out locations, and Table 7-2 lists the connector pin mappings. (All unconnected pins should be left floating.)

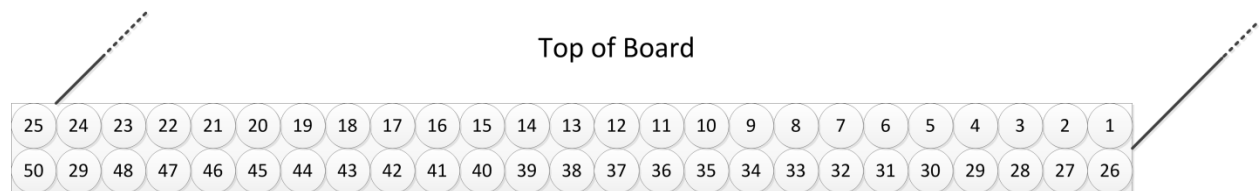

Figure 6-2: M2-CF Pin Numbering

Pin	Name	Description	Pin	Name	Description
1	GND	Ground	26	GND	Ground
2	VCC	Supply voltage	27	GND	Ground
3	VCC	Supply voltage	28	SCL	I ² C Clock
4	DPOS	USB positive	29	SDA	I ² C Data
5	DNEG	USB negative	30	NC	Not connected
6	GND	Ground	31	NC	Not connected
7	MISO	SPI master-in, slave-out	32	GPIO 0	General-purpose I/O
8	MOSI	Master-out, slave-in for SPI	33	GPIO 1	General-purpose I/O
9	SSEL	Slave select for SPI	34	GPIO 2	General-purpose I/O
10	SCK	SPI clock	35	NC	Reserved
11	NC	Reserved	36	NC	Reserved
12	NC	Reserved	37	NC	Not connected
13	NC	Not connected	38	NC	Not connected
14	RXD	UART receive	39	NC	Not connected
15	TXD	UART transmit	40	NC	Reserved
16	NC	Reserved	41	NC	Reserved
17	NC	Reserved	42	NC	Not connected
18	NC	Not connected	43	GPIO 3	General-purpose I/O
19	NC	Reserved	44	GPIO 4	General-purpose I/O
20	NC	Reserved	45	GPIO 5	General-purpose I/O
21	NC	Reserved	46	GPIO 6	General-purpose I/O
22	NC	Reserved	47	NC	Not connected
23	NC	Reserved	48	NC	Not connected
24	NC	Reserved	49	GND	Ground
25	GND	Ground	50	NC	Not connected

Table 6-3: SkyeModule M2-CF Pin Descriptions



CAUTION - If you perform custom integration work on your SkyeModule M2, make sure that you connect all available power and ground pins. Failure to do so reduces read range and could cause failure of the module. (Pins listed as not connected should be left floating.)

6.3 Using the GPIO Pins

You can use the User Port Direction and User Port Value system parameters to address the GPIO pins to set the user port direction (input or output) and the user port value (high or low). For more information, see the following:

- “User Port Direction” in section 13.2.9
- “User Port Value” in section 13.2.10
- “GPIO Toggle on Select” in section 13.2.13



7 Environmental Specifications

7.1 Electrostatic Precautions



CAUTION - Failure to take proper electrostatic precautions may result in damage to or failure of your SkyeModule M2.

The SkyeModule M2 contains static-sensitive parts. Observe the following precautions to prevent damage to these parts.

- Wear a static grounding strap when handling electronic control components.
- Keep all plastic, vinyl, and styrofoam (except antistatic versions) away from printed circuit boards.
- Do not touch the components or conductors on a printed circuit board with your hands or with conductive devices.

7.2 General Ratings and Operating Conditions

Specification	Rating
Temperature range	Temperature is 25 degrees Celsius unless otherwise noted
Operating	-10 to +70 degrees C
Storage	-20 to +85 degrees C
Humidity	
Operating, continuous storage	10-90 percent (non-condensing)
Transient storage (<24 hours)	5-95 percent maximum (non-condensing)
ESD protection	< 1kV (ESD HBM 15500 Ω , 100pF) –or– 100V (ESD MM 0.75uH, 200pF)

Table 7-1: Environmental Ratings/Operating Conditions



Skyetek Inc
1732 Wazee St. Ste 202
Denver, CO 80202
www.skyetek.com

8 Electrical Specifications

This chapter discusses the electrical specifications of the SkyeModule M2. Unless otherwise noted, the following assumptions apply to these specifications:

- Temperature is 25 degrees Celsius.
- Frequency is 13.56 MHz.
- Supply voltage (VCC) is 5 V.

Specification	Min	Typ	Max	Units/Notes
RF Characteristics				
Frequency ranges (Direct output)		13.56		MHz
Transmission Parameters				
Transmit Power		23.0 ± 2		dBm
Optimum PA Load Impedance		50		Ohms
Logic Inputs				
High state input voltage	2			V
Low state input voltage			0.8	V
Input Current (IINH/IINL)			4	mA
Logic Outputs				
Output High Voltage (VOH)	2.8	3.3	3.6	V
Output Low Voltage (VOL)			0.3	V
Output Current (IINH/IINL)			4	mA
Power Supplies				
Voltage Supply	3.5	5.0	5.5	V
Continuous Transmit Current Consumption (23 dBm)		150	200	mA
Low Power Sleep Mode		2.5	3	mA

Table 8-1: SkyeModule M2 Electrical Specifications

8.1 Absolute Maximum Ratings

Temperature for these specifications is assumed to be 25 degrees Celsius unless otherwise noted.

Specification	Rating
Maximum input voltage, high (V_{INH})	5.5 V
V_{SUPPLY} to GND	5.5 V
Digital I/O voltage to GND	5.5 V



Skyetek Inc
1732 Wazee St. Ste 202
Denver, CO 80202
www.skyetek.com

Table 8-2: Absolute Maximum Ratings/Operating Conditions

9 Host Interface Specifications

The SkyeModule M2 supports the following microcontroller host interfaces for easy integration into existing systems:

- TTL Serial
- SPI
- USB
- I²C

The SkyeModule M2 and the host interface board support TTL Serial and USB communications. The host interface board provides a USB connector and a TTL to-RS-232-level converter for the TTL Serial host interface. The Host Interface system parameter determines which host interface is used to communication with the host. Each interface is software selectable and only one host interface is active at a time. The host interface is selected based on the power-up default value and can be changed at run time. The SkyeModule M2 operates under host control using SkyeTek Protocol v3 sent over one of the host interfaces described in this chapter.

The following sections describe the power and host communication connections for the SkyeModule M2.



9.1 TTL Serial

Figure 9-1 shows a sample circuit that lets you connect the SkyeModule M2 without the host interface board.



CAUTION - Be sure to connect both supply voltage and both ground lines to allow sufficient current draw. Failure to do so could cause damage to or failure of the host computer or of the SkyeModule M2.

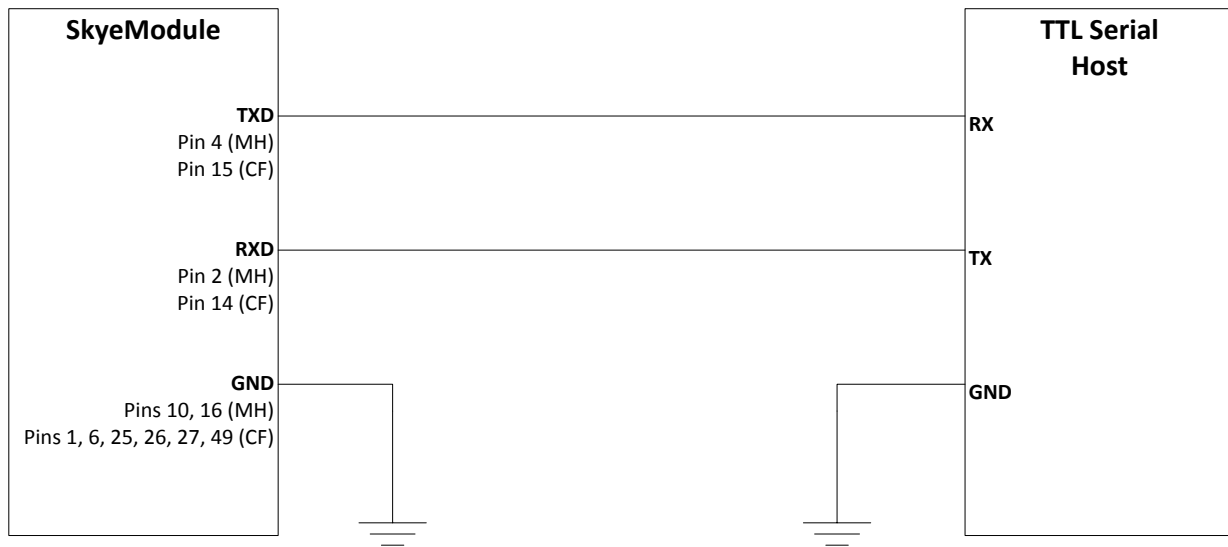

Figure 9-1: TTL Serial Connection Diagram

A two-wire serial connection (no handshaking) is provided on the TXD and RXD lines where TXD and RXD are from the module's point of view. Data exchange between the host and the SkyeModule M2 occurs according to SkyeTek Protocol v3 (ASCII or Binary mode). Figure 9-2 shows examples of typical communication.



Skyetek Inc
 1732 Wazee St. Ste 202
 Denver, CO 80202
 www.skyetek.com

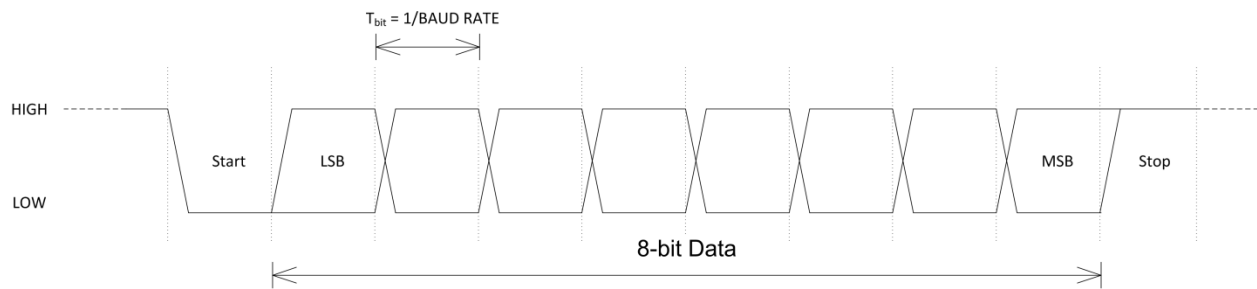

Figure 9-2: TTL Serial Timing Diagram

- Baud rate is selectable via the appropriate system parameter. Preprogrammed factory default baud rate is 38,400 Baud.
- Bytes are transmitted least-significant bit (LSB) first using the typical serial data format of *Start Bit* followed by *8 data bits* followed by a *Stop Bit*.
- The TTL Serial connection supports bit rates from 9,600 to 115,200 baud, 8 data bits, no parity, 1 stop bit.
- Host to reader interface shall be TTL level (non-inverted).
- TTL low = 0 to 0.8V; TTL high = 2.0 to 5V

9.2 SPI

The SkyeModule M2 provides a simple four-wire SPI host interface. Figure 9-3 shows an example of a host interface connection using SPI.



Figure 9-3: SPI Connection Diagram

The protocol for requests to the SkyeModule M2 is as follows:

- The host must implement SPI master functionality.
- The data packet exchange between the host (SPI Master) and the M2 (SPI Slave) uses SkyeTek Protocol v3 (Binary Mode only).
- The SCK line is the master clock controlled by the host and should remain low during idle state.
- The slave select line is active low.
- The data is setup on the rising edge of SCK.
- The message data is latched on the falling edge of SCK.
- The MOSI signal line provides the data from the host to the SkyeModule M2.
- Low = 0 to 0.8 V; High = 2.0 to 5 V.

The timing diagram in Figure 9-4 illustrates this behavior.

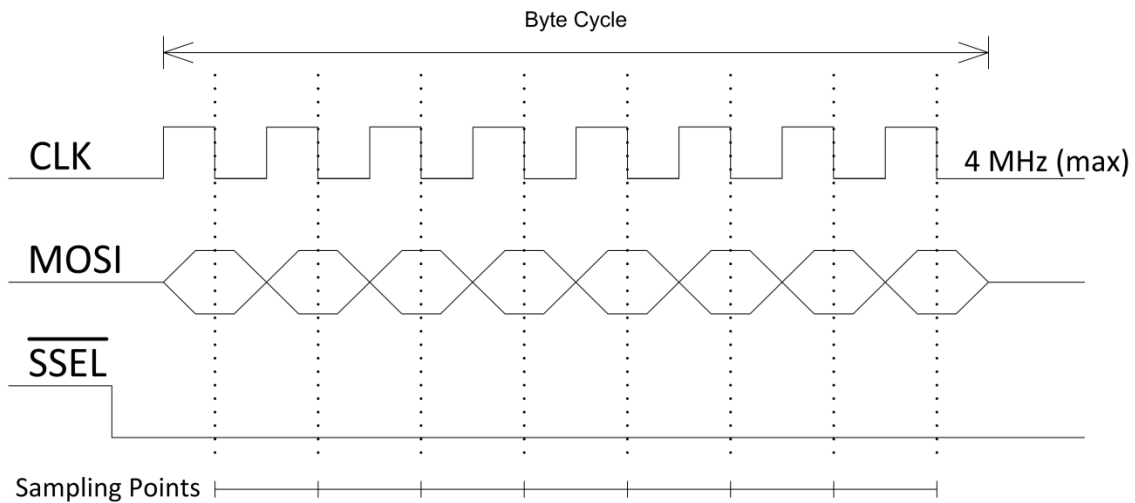

Figure 9-4: SPI Request Setup and Sample Timing

- For the request data on the MOSI line, the host software should keep the SSEL pin at steady state low as shown in Figure 9-5 below.
- The time delay $T_{d,MAX}$ between byte cycles in a request should not exceed 5 ms. After 5 ms the SkyeModule M2 will timeout, signifying the end of the request.

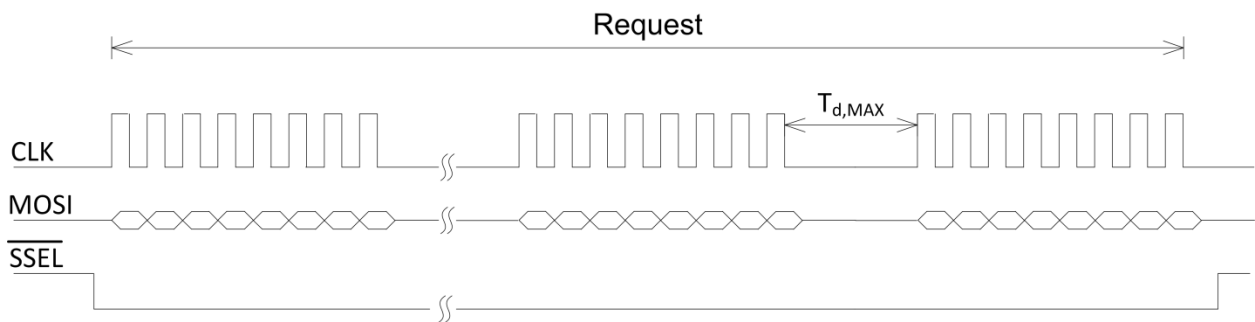

Figure 9-5: SPI Request Timing

The protocol for retrieving the response data is outlined below.

- The SkyeModule M2 is half duplex so the response data must be retrieved after the request has been sent.
- The MISO signal provides the response data from SkyeModule M2 to host.
- To retrieve data on the MISO line, the SSEL (Slave Select) signal must toggle low-high-low between clocked-back bytes.

Figure 9-6 below shows the timing required to retrieve data on the MISO line.

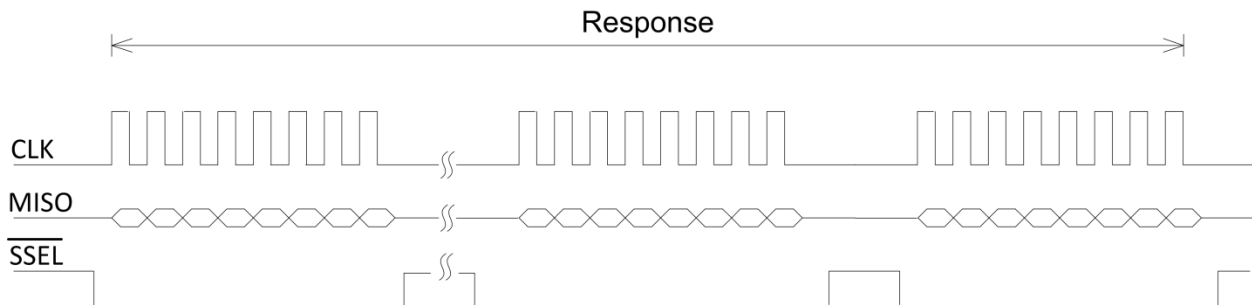

Figure 9-6: SPI Response Timing

9.3 USB 2.0

- As a USB device, the host detects the SkyeModule M2 as an HID device. (Note that the SkyeModule M2 uses a standard HID driver and is not a certified USB device.)
- The SkyeModule M2 supports both standard and high speed USB and enumerates correctly on both Windows and UNIX platforms.
- Maximum data rates are 41 Kbps from the reader to the host and 62 Kbps from the host to reader.

Figure 9-7 shows an example of a circuit to permit USB communications without using the host interface board.

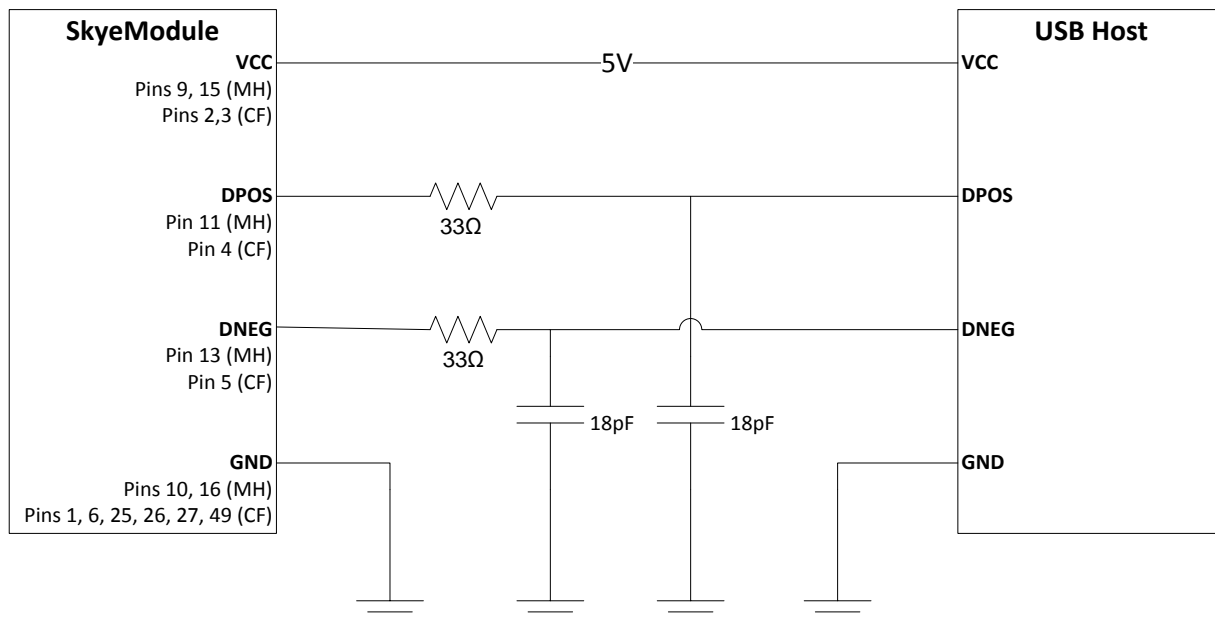

Figure 9-7: USB Connection Diagram

9.4 I²C

The SkyeModule M2 supports the I²C standard for connecting to a host controller. The device connection requires that external pull up resistors be added to the SDA and SCL lines as shown in Figure 10-9.

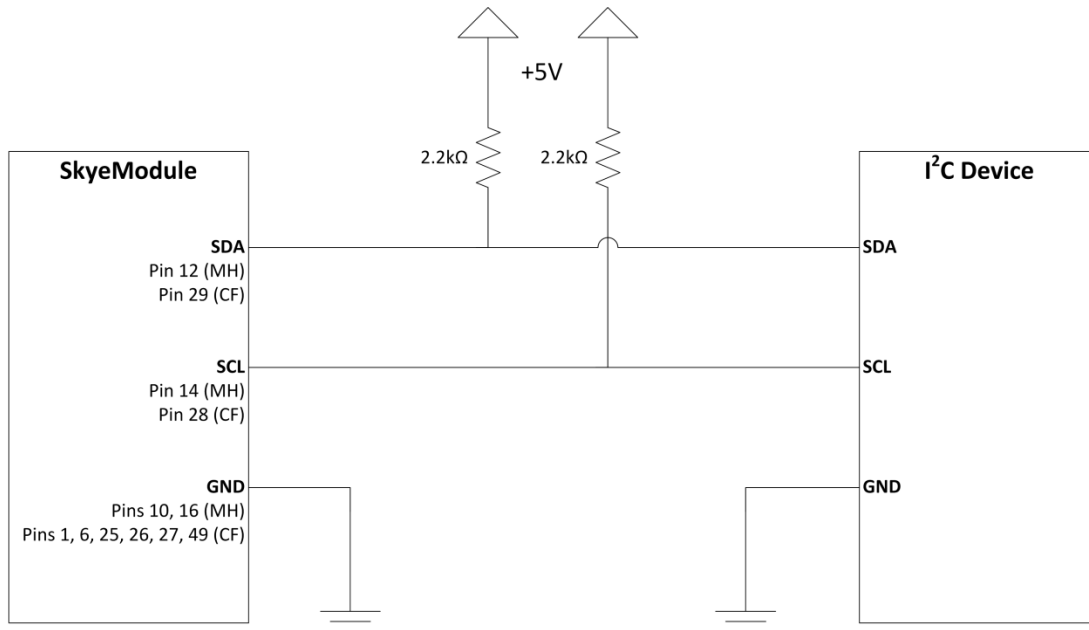

Figure 9-8: I2C Connection Diagram

The SkyeModule M2 requires the host to operate as a master.

- The SPI interface uses a standard two-wire connection in which SCL is the master clock and SDA is a bidirectional serial data line.
- Data exchange between the host and the SkyeModule M2 uses SkyeTek Protocol v3 (Binary Mode only).
- I²C fast mode (400 kHz) is supported, as is the slower 100kHz data rate.
- The data is sent and received MSB first.
- Low = 0 to 0.8V; High = 2.0 to 5V.
- The device address is 0x7F.
- The communication scheme from host to module is as follows:
 - Initiate a start condition (SDA transitions low while SCL is high).
 - Send the nine bits of the initial start packet as follows:
 - Send the 7-bit address.
 - Send the read/write bit as the eighth bit (0 for writing from the host to the slave).
 - Send the ninth bit as the “acknowledge” bit (ACK), which is automatically handled.

- If the reader recognizes the address, it pulls SDA low.
- Use the bus to clock each byte of the SkyeTek protocol request.
- After sending the request, initiate a stop condition. (SCL transitions high, and then SDA transitions high while SCL is high)

NOTE - You may need to include from one to a few hundred milliseconds of delay between request and response. The delay may vary for tag-specific commands.

- Communication scheme from module to host is as follows:
 - Initiate a start condition. (SDA transitions low, and then SCL transitions low.)
 - Send the 7-bit address.
 - Send the read/write bit as the eighth bit (1 for reading from the slave to the host).
 - If the reader recognizes the address, it pulls SDA low for the ACK bit.
 - If the address isn't recognized or the module is busy the SDA bit will remain high during the ACK bit.
 - Clock each byte of the SkyeTek protocol response from the module.
 - After receiving the response, is received, initiate a stop condition. (SDA transitions high while SCL is high.)
 - SDA must transition while the clock is low and remain stable while the clock is high.

A timing diagram illustrating the data transfer is shown in the figure below.

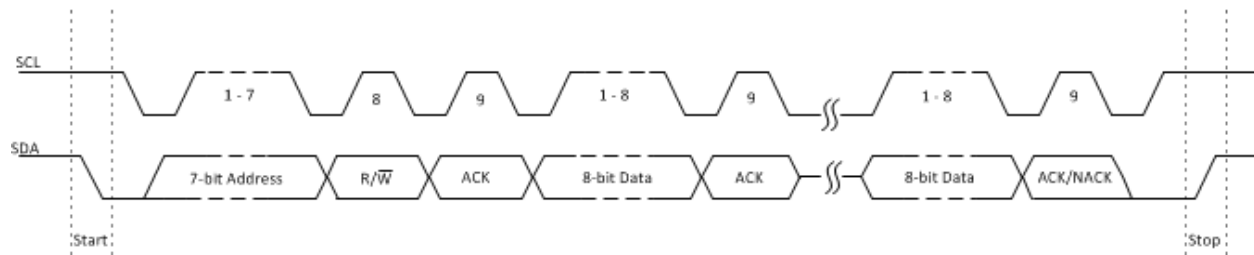

Figure 9-9: I2C Timing Diagram

NOTE - Not reading the entire response before sending another command can cause undesired behavior. Always make sure to read the entire response when using the I²C interface.

10 Radio Specifications

10.1 Agency Approvals

As part of a host system, the SkyeModule M2 will not interfere with the overall system's compliance with agency requirements for emissions and susceptibility, including:

- United States: FCC 15.225
- Europe: EN300-330, EN301-489, EN 61000-4-3, RoHS
- Australia/New Zealand: AS/NZS 4268:2003
- Taiwan: DGT LP002
- Hong Kong: HKTA 1035
- Singapore: IDA TS SRD

10.2 Frequency Band

The M2 operates in the 13.56MHz (+/- 7KHz) ISM unlicensed band and is suitable for worldwide use. The frequency is not adjustable.

10.3 Tag Protocols

The SkyeModule M2 supports the basic tag commands (identify, read, and write) for the following tag types:

- ISO 14443A
- ISO 14443B
- ISO 15693
- Selected proprietary formats, including NXP, Infineon, and EM Microelectronics.

For the most current listing of supported tags and features, see the [SkyeModule M2 Tag Support List](#).



11 SkyeModule M2 Antenna Options

You can use the SkyeModule M2 with an on-board antenna, a standard 50 Ω (13.56MHz) external antenna, or a multiplexer for multiple external antennas.

Internal Antenna - The SkyeModule M2 includes an internal PCB trace loop antenna, located on the bottom of the module. Useful for space-constrained applications that require less read range, this antenna is active unless an external MMCX plug is inserted into the MMCX jack.

External Antenna - The M2 includes a switching MMCX jack for connecting an external 50 Ω (13.56MHz) matched antenna, which can maximize read range. A sample external antenna is included with a SkyeTek developer kit.

SkyePlus® MXH - The SkyePlus MXH multiplexer provides four or eight ports for external antennas. You can use multiple multiplexers to increase the number of antennas each M2 module can support. Digital control is accomplished by either the host processor or reader module. This permits explicit addressing of any of the eight antennas, using three GPIO pins.

- Low insertion loss: < 1.5 dB
- Isolation: 45 dB minimum
- Control voltage: CMOS/TTL levels

See the [SkyePlus Multiplexer Reference Guide](#) for more information.

Read range depends on antenna choice and operating environment. Range can vary widely, depending on your choice of tag inlay and antenna gain. Table 11-1 shows some expected read ranges for internal and external antennas.

Antenna	ISO15693 Credit Card Tag	ISO14443A PVC Credit Card Tag	ISO14443B Paypass Inlay
Internal	4.0 in./10.2 cm	2.5 in./6.4 cm	1.0 in./2.5 cm
External (SkyeTek DK External)	7.0 in./17.8 cm	5 in./12.7 cm	3.0 in./7.6 cm

Table 11-1: Estimated Read Ranges



Skyetek Inc
1732 Wazee St. Ste 202
Denver, CO 80202
www.skyetek.com

12 Communicating with the Module

12.1 Host Communication (SkyeTek Protocol v3)

The SkyeModule M2 operates under control of a host computer according to SkyeTek Protocol v3. For more information about this protocol, including commands, flags, request and response formats, please see the [SkyeTek Protocol v3 Reference Guide](#).

The basic command and response formats are illustrated in the following two sections.

12.2 Request Formats

Flags	Cmd.	RID	Tag Type	TID Len.	TID	AFI	Addr.	# of Blks.	Data Len.	Data	CRC
4	4	8	4	4	32 (max)	2	4	4	4	2K	4

Table 12-1: Request Format (bytes), ASCII Mode

Msg. Len	Flags	Cmd.	RID	Tag Type	TID Len	TID	AFI	Addr.	# of Blks	Data Len.	Data	CRC
2	2	2	4	2	1	16 (max)	1	2	2	2	1K	2

Table 12-2: Request Format (bytes), Binary Mode

	Required Fields (must be present at all times)
	Optional fields (depending on the command and flags)
	Required fields, depending on the command



Skyetek Inc
1732 Wazee St. Ste 202
Denver, CO 80202
www.skyetek.com

12.3 Response Formats

Message Length	Response Code	RID	Tag Type	Data Length	Response Data	CRC
2	2	4	2	2	1K	2

Table 12-3: Response Format (bytes), Binary Mode

	Required Fields (must be present at all times)
	Optional fields (depending on the command and flags)
	Required fields, depending on the command



13 Customizing System Parameters

System parameters let you configure reader settings to customize the reader for your environment. You can temporarily alter parameters in memory or change the default values that are stored on the SkyeModule M2 non-volatile memory. The following table summarizes the parameters for the SkyeModule M2. (See System Parameter Descriptions in section 13.2 for detailed information about each parameter)

Parameter Name	Address (hex)	Num. Blocks (hex)	Default Value
Serial Number	0x0000	0x0004	0x00000000
Firmware Version	0x0001	0x0004	0XXXXXXXX (depending on release)
Hardware Version	0x0002	0x0004	0XXXXXXXX (depending on release)
Product Code	0x0003	0x0002	0x0002
Reader ID	0x0004	0x0004	0xFFFFFFFF
Reader Name	0x0005	0x0032	SkyeModule M2 (in hex)
Host Interface Type	0x0006	0x0001	0x01 (TTL)
Host Interface Baud Rate	0x0007	0x0001	0x02 (38400)
User Port Direction	0x0008	0x0001	0x00
User Port Value	0x0009	0x0001	0x7F
MUX Control	0x000A	0x0001	0x00
Operating Mode	0x000C	0x0001	writing 01 puts the device to sleep
GPIO Toggle on Select	0x0013	0x0001	0x00

Table 13-1: SkyeModule M2 System Parameters

13.1 Changing System Parameters



CAUTION - Changing system parameter values - especially the default values - can render your SkyeModule M2 non-operational in your environment. Research, record, and test all planned changes to make sure they are compatible with your system.

You can read or write system parameters via the following commands:

- Read System Parameter - Reads the current value of the system parameter at the memory address specified.
- Write System Parameter - Writes a new value to the system parameter at the memory address specified.
- Store Default System Parameter - Writes a new system parameter value to the non-volatile memory. This saves the setting even after a power cycle or reset.



Skyetek Inc
1732 Wazee St. Ste 202
Denver, CO 80202
www.skyetek.com

- Retrieve Default System Parameter - Reads the system parameter value at the address specified out of non-volatile memory.

See System Parameter Descriptions in section 13.2 for detailed information about individual parameters.

For full examples of how to use these commands, see the system parameter examples found in [Using SkyeProtocol V3 Reader Commands](#). Also, see the [SkyeTek Protocol v3 Reference Guide](#) for a complete list of commands and the communication protocol specification.



CAUTION - Resetting (cycling power) on your SkyeModule M2 causes all system parameters to revert to their default values. Any changes made to system parameters in memory are lost at reset unless you write them to the non-volatile memory as the new default values. Any changes to the default values do not take effect until the reader is reset.

13.2 System Parameter Descriptions

This section describes the SkyeModule M2 system parameters.

13.2.1 Serial Number

- Returns the serial number of the reader
- Parameter address: 0x0000
- Length (bytes): 4
- Default value: 0x00000000
- Read-only

13.2.2 Firmware Version

- Returns the firmware version currently loaded on the reader.
- Refer to the [SkyeWare User Guide](#) for information about updating firmware.
- Parameter address: 0x0001
- Length (bytes): 4
- Default value: 0XXXXXXXX (depending on release)
- The firmware version uses this format:
 - Major revision (1 Byte)
 - Minor revision (1 Byte)
 - Current build number (2 bytes)
- Read-only



Skyetek Inc
1732 Wazee St. Ste 202
Denver, CO 80202
www.skyetek.com

13.2.3 Hardware Version

- Returns the current hardware version of the reader
- Parameter address: 0x0002
- Length (bytes): 4
- Default value: 0XXXXXXXX (depending on release)
- The hardware version uses the following format:
 - Major revision (1 Byte)
 - Minor revision (1 Byte)
 - Current build number (2 bytes)
- Read-only

13.2.4 Product Code

- Returns the SkyeTek product code identifier. (Each SkyeTek Product has a unique product code.)
- Parameter address: 0x0003
- Length (bytes): 2
- Default value: 0x000A
- Read-only

13.2.5 Reader ID

- Specifies the Reader ID, which is a reader-specific identifier. It lets the reader execute and respond only to those commands intended for it. The reader determines if the Reader ID in the request matches its internal Reader ID. If the ID does not match, the reader does not respond.
- Parameter address: 0x0004
- Length (bytes): 4
- Default value: 0xFFFFFFFF
- Select the Reader ID functionality by specifying the RID Flag in the request. This setting lets you use multiple readers on the same bus or networked together.
- Read/write

13.2.6 Reader Name

- Identifies a reader with a 32-byte user-defined name.
- Parameter address: 0x0005
- Length (bytes): 32 (20 hex)
- Default value is “SkyeModule M2” (in hex)
- Read/write



Skyetek Inc
1732 Wazee St. Ste 202
Denver, CO 80202
www.skyetek.com

13.2.7 Host Interface Type

- Identifier for the type of host interface being used.
- Parameter address: 0x0006
- Length (bytes): 1
- Default value: 0x01 (TTL)
- Valid host interface values are:
 - 0x01 - TTL Serial
 - 0x03 - SPI
 - 0x05 - I²C
 - 0x06 - USB
 - Any other values are invalid and are ignored.
- Read/write

13.2.8 Interface Baud Rate

- Sets the baud rate of the host interface.
- Works for the TTL Serial host interface only.
- Parameter address: 0x0007
- Length (bytes): 1
- Default value: 0x02 (38,400)
- Valid baud rate values are:
 - 0x01 - 19200
 - 0x02 - 38400
 - 0x03 - 57600
 - 0x04 - 115200
 - Any other value - 9600
- Read/write

13.2.9 User Port Direction

- Sets the direction of the GPIO pins of the reader.
- Parameter address: 0x0008
- Length (bytes): 1
- Default value: 0x00
- Default value is 0x00 (GPIO pins are outputs).
- A one in the bit position indicates that the corresponding GPIO pin is an input.
- A zero in the bit position indicates that the corresponding GPIO pin is an output.
- Bits correspond to the pins as follows:
 - BIT0 - GPIO 0
 - BIT1 - GPIO 1
 - BIT2 - GPIO 2
 - BIT3 - GPIO 3



Skyetek Inc
1732 Wazee St. Ste 202
Denver, CO 80202
www.skyetek.com

- BIT4 - GPIO 4
- BIT5 - GPIO 5
- BIT6 - GPIO 6
- BIT7 - Enable
- Read/write

13.2.10 User Port Value

- Sets or reads the value of the GPIO pins of the reader.
- Parameter address: 0x0009
- Length (bytes): 1
- Default value is 0x7F (GPIO pins are logic high).
- A one in the bit position indicates that the corresponding GPIO pin is logic high.
- A zero in the bit position indicates that the corresponding GPIO pin is logic low.
- The enable bit (bit 7) must be set for the settings to take effect.
- Bits correspond to the pins as follows:
 - BIT0 - GPIO 0
 - BIT1 - GPIO 1
 - BIT2 - GPIO 2
 - BIT3 - GPIO 3
 - BIT4 - GPIO 4
 - BIT5 - GPIO 5
 - BIT6 - GPIO 6
 - BIT7 - Enable
- Read/write

13.2.11 MUX Control

- Controls a SkyePlus multiplexer. See the [SkyePlus Multiplexer Reference Guide](#) for complete information about using this parameter.
- Parameter address: 0x000A
- Length (bytes): 1
- Default value: 0x00 (Mux Control disabled)
- Read/write

13.2.12 Operating Mode

- Puts the reader into sleep mode.
- Parameter address: 0x000C
- Length (bytes): 1
- Default value is 0x00 (active).



Skyetek Inc
1732 Wazee St. Ste 202
Denver, CO 80202
www.skyetek.com

- Writing a value 0x01 to this system parameter puts the reader in sleep mode. (Not supported with the USB host interface.)
- Sending any command on any interface wakes the reader from sleep mode.
- Read Only

13.2.13 GPIO Toggle on Select

- Sets GPIO 0 to toggle high on any Select command (with Inventory, Loop, or Loop plus Inventory flags).
- Parameter address: 0x0013
- Length (bytes): 1
- Default value: 0x00 (disabled)
- GPIO 0 remains high for a period of time defined by the value for this parameter, multiplied by one millisecond with a maximum of 255 ms. For example, a system parameter value of 0x0A indicates a high period of 10ms.
- Overrides current GPIO settings.
- Can be stored in nonvolatile memory via a Store Default System Parameter command.
- The response to the Select command is not available to the host interface until after GPIO 0 has toggled.
- A value of 0x00 disables this function
- Read/write



14 Operating Modes

The SkyeModule M2 has three operating modes: Sleep, Active, and Loop. The low-power Sleep mode can be used to conserve battery or system power.

The reader can be put into sleep mode by writing the data 0x01 to the Operating Mode system parameter using the Write System Parameter command. After the reader gives a positive response, it enters Sleep mode. Any command wakes the reader from Sleep mode. Even sending a single byte to the reader wakes it from Sleep mode. The reader gives the same positive response upon waking from sleep mode as it gives upon entering Sleep mode. The following example illustrates putting the module to sleep using a binary mode request.

Request

Start	Message Length	Flags	Command	Address	Number of Blocks	Data Length	Data	CRC
02	000D	8201	2020	00C0	0001	0001	01	D0CF

Response

Start	Message Length	Command Response	CRC
02	0004	1202	E652

The module responds with a success message and then goes to sleep. Any command can be used to wake the module up however the following example uses the basic select tag command to wake the module up.

Request

Start	Message Length	Flags	Command	Tag Type	CRC
02	0008	0020	0101	0000	F81A

Response

Start	Message Length	Command Response	CRC



Skyetek Inc
 1732 Wazee St. Ste 202
 Denver, CO 80202
www.skyetek.com

02	0004	1202	E652
----	------	------	------

The module responds with the same success message as when put to sleep indicating that the device is awake. Note that the select tag command would have to be sent again to actually select a tag, as the first command just wakes the module up from sleep.

Active mode is the main operating mode of the reader. Loop mode is entered by sending a select tag command with the loop flag present. The reader will then continuously poll for tags and send any tags found back to the host with no other command request required by the host. Examples of this can be found in [Using SkyeProtocol V3 Basic Examples](#). Also, see the [Skyetek Protocol v3 Reference Guide](#) for a complete list of commands and the communication protocol specification.





Компания «ЭлектроПласт» предлагает заключение долгосрочных отношений при поставках импортных электронных компонентов на взаимовыгодных условиях!

Наши преимущества:

- Оперативные поставки широкого спектра электронных компонентов отечественного и импортного производства напрямую от производителей и с крупнейших мировых складов;
- Поставка более 17-ти миллионов наименований электронных компонентов;
- Поставка сложных, дефицитных, либо снятых с производства позиций;
- Оперативные сроки поставки под заказ (от 5 рабочих дней);
- Экспресс доставка в любую точку России;
- Техническая поддержка проекта, помощь в подборе аналогов, поставка прототипов;
- Система менеджмента качества сертифицирована по Международному стандарту ISO 9001;
- Лицензия ФСБ на осуществление работ с использованием сведений, составляющих государственную тайну;
- Поставка специализированных компонентов (Xilinx, Altera, Analog Devices, Intersil, Interpoint, Microsemi, Aeroflex, Peregrine, Syfer, Eurofarad, Texas Instrument, Miteq, Cobham, E2V, MA-COM, Hittite, Mini-Circuits, General Dynamics и др.);

Помимо этого, одним из направлений компании «ЭлектроПласт» является направление «Источники питания». Мы предлагаем Вам помощь Конструкторского отдела:

- Подбор оптимального решения, техническое обоснование при выборе компонента;
- Подбор аналогов;
- Консультации по применению компонента;
- Поставка образцов и прототипов;
- Техническая поддержка проекта;
- Защита от снятия компонента с производства.



Как с нами связаться

Телефон: 8 (812) 309 58 32 (многоканальный)

Факс: 8 (812) 320-02-42

Электронная почта: org@eplast1.ru

Адрес: 198099, г. Санкт-Петербург, ул. Калинина, дом 2, корпус 4, литера А.