

FND300-1012G Power Supply

DC Input, 12V Output, 300 W



The FND300-1012G is a highly-efficient bus converter with one high current output, which can be used in a wide range of applications. Passive current share along with internal ORing diodes allow this unit to be also used in redundant, hot-swap applications.

The FND300 meets international safety standards and displays the CE Mark for the Low Voltage Directive.

Key Features & Benefits

- RoHS compliant for all six substances
- 40.5 to 72 VDC Input Range
- 12 V output
- 2000 VAC I/O electric strength test
- Highly-efficient topology
- High-density design
- 4" x 1.65" x 8.5" cassette
- I²C interface
- Supervisory signaling
- Overtemperature, output overvoltage, and output overcurrent protection
- ORing diode included for true redundant operation
- Safety approvals: UL60950-1/ CSA 60950-1, & TUV EN60950-1

Applications

- Telecommunication Equipment

North America

+1-866.513.2839

Asia-Pacific

+86.755.29885888

Europe, Middle East

+353 61 225 977

tech.support@psbel.com

belpowersolutions.com

FND300-1012G

Model Selection

MODEL	NOMINAL OUTPUT VOLTAGE (VDC)	INPUT CURRENT MAX (ADC)	ADJUSTMENT RANGE (VDC)	OUTPUT RATED CURRENT I _{RATED} (ADC)	OUTPUT RIPPLE/NOISE, mV p-p	TYPICAL EFFICIENCY @ I _{RATED} %
FND300-1012G	12	10	N/A	25	<120	>80

Input Specifications

PARAMETER	CONDITIONS / DESCRIPTION	MIN	NOM	MAX	UNITS
Input Voltage	With full output power	40.5	48/60	72	VDC
Inrush Current Limitation	48 / 60 VDC			<12 / 15	A
Efficiency	V _I nom, I _o nom			>80	%

Output Specifications

PARAMETER	CONDITIONS / DESCRIPTION	MIN	NOM	MAX	UNITS
Nominal Output Current V1	V _I min to V _I max		25		A
Output Voltage Setting V1	V _I nom, 12.5 A, T _c = 25 °C		12.0		VDC
Static Line Regulation V1	V _I min to V _I max, V _I nom, 5 to 100% I _o nom			±0.5	%
Static Load Regulation V1* * (Droop Characteristic)	V _I min to V _I max, V _I nom, 5 to 100% I _o nom			±5	%
Minimum Load	No minimum load requirements				
Hold-Up Time	At full load, starting at V _I = 60 VDC			>8	ms
Dynamic Load Regulation Settling Time	V1: ΔI _o = 8A, dI _o /dt = 2A/μs			±2 400	%V _{out} μs
Start-Up Time	V _I nom, I _o nom			<1	s
Output Voltage Ripple And Noise	V _I nom, I _o nom, 20 MHz BW			<120	mVp-p

Interface Signals and Internal Protection¹

PARAMETER	CONDITIONS / DESCRIPTION	MIN	NOM.	MAX	UNITS
Overvoltage Protection	Latch-style overvoltage protection.			14.5	V
Overcurrent Protection	(Latch-style) 110 to 120% I _o nom				
Overtemperature	Self-recovery; shut down at T _c = 95 °C				
Input Fuses	15 AF, Not user-accessible				
Input Transient Protection	VDR, reverse polarity protection				
I ² C Digital Bus	Reports information and monitors alarm functions				
PS Seated Signal	Contact closure to GND				
PS Remote Shut Down	TTL-compatible signal, inhibited at High or TTL "1"				
Power Fail	Indicates output voltage is out of regulation				
Fan Fail	Indicates low fan speed				
Current Share	Droop load characteristic				

FND300-1012G

Environmental, Mechanical Specifications & Reliability

PARAMETER	CONDITIONS/DESCRIPTION	MIN	NOM	MAX	UNITS
Operating Temperature	1/2 min to 1/2 max, 1/2 nom, cooling by internal fan	0		55	°C
Storage Temperature	Ambient	-40		85	°C
Operating Humidity	Relative Humidity, Non-cond.	10		90	%
Storage Humidity	Relative Humidity, Non-cond.	5		95	%
Shock	IEC/EN 60068-2-27, 11 ms			30	g
Sinusoidal Vibration	IEC/EN 60068-2-6			7.5	mm
	2 to 8 Hz			2	g _n
	8 to 200 Hz			4	g _n
Weight			1		kg
Dimensions	(Overall)	8.5 L (215.9)	4.0 W (101.6)	1.65 H (41.9)	in (mm)
MTBF	MIL-HDBK-217F Notice 2, G _B , 25 °C		150'000 (calculated)		h

Safety Regulatory Compliance & EMC

SAFETY AGENCY OR PARAMETER	STANDARD APPROVED TO:	MARKING OR RELATED TEST VALUE
UL/CSA	UL60950-1 / CSA 60950-1	
TUV Product Service	TUV EN60950-1	
Electric Strength Test Voltage	Class I, I/case (basic insulation)	1.41 kVDC
Electric Strength Test Voltage	Class I, I/O (reinforced insulation)	2.82 kVDC
Electrostatic Discharge	IEC/EN 61000-4-2, level 4 (contact/air)	8/15 kV, criterion B
Electromagnetic Field	IEC/EN 61000-4-3, level 3	10 V/m, criterion A
Electrical Fast Transients / Burst	IEC/EN 61000-4-4, level 4 (direct capacitive)	4/2 kV, criterion B
Surge	IEC/EN 61000-4-5, level 2 (L/L, L/C)	0.5/1 kV, criterion B
Electromagnetic Emissions	CISPR 22/EN 55022/EN61204 conducted/radiated	Class B

Output Connector Pin Allocation

PIN	SIGNAL NAME	DESCRIPTION
1-3, 13-15	V1 RTN	V1 Output Return
4-6, 16-18	V1	V1 Output
7	-	Not Used
8	-	Not Used
9	PF	Power Fail
10	I ² C	I ² C Voltage Input/Output
11	SDA	Serial Data Line
12	SCL	Serial Clock Line
19	-	Not Used
20	-	Not Used
21	LSB	Address Input Line
22	RSD	Power Supply Remote Shut Down
23	PS_PRSNT_L	Power Supply Present signal
24	Fan Fail	Fan Fail signal

866.513.2839

tech.support@psbel.com

belpowersolutions.com

FND300-1012G

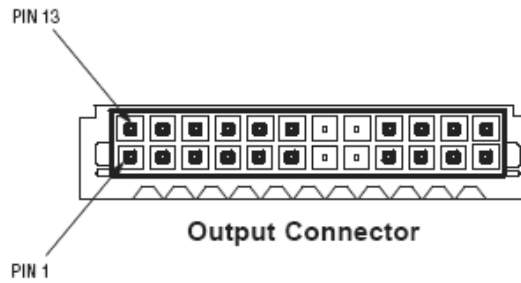

Connector Information

Power Supply:

Output - 24-Pin Molex connector 15-06-0241 with pre-plated tin over copper Molex terminals 39-00-0038

Mating Connections:

Output - 24-Pin Molex connector 15-06-0245 with pre-plated tin over copper Molex terminals 39-00-0040

Airflow Direction



Characteristic Curves

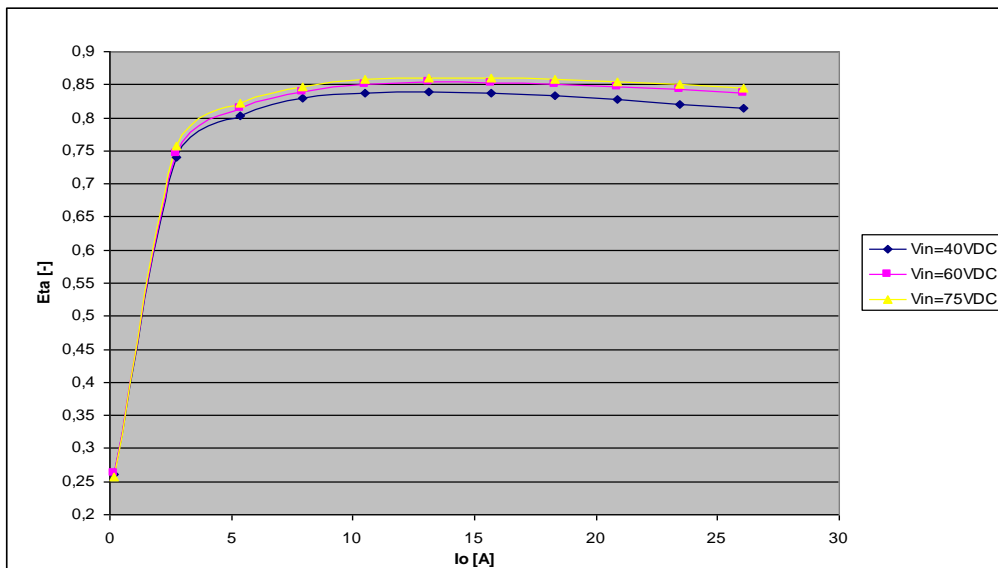

FND300-1012G

Figure 1 - Efficiency vs. Output Load

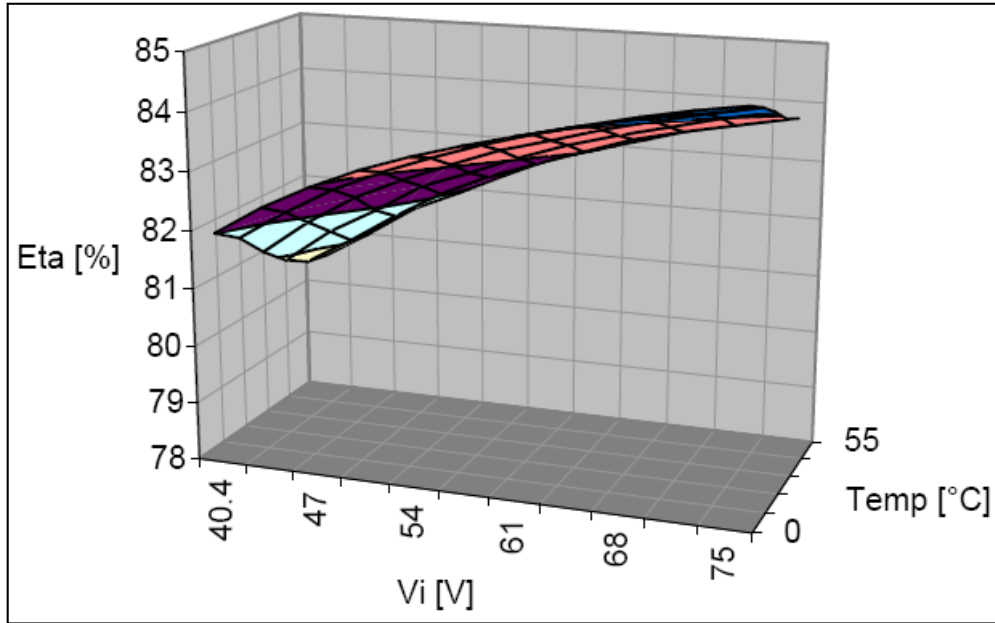

Figure 2 - Efficiency vs. Input Voltage and Ambient Temperature, $I_o=I_{onom}$

Mechanical

PARAMETER	CONDITIONS / DESCRIPTION
Overall Dimensions (L x W x H)	215.9 x 101.6 x 41.9 mm (8.5 x 4.0 x 1.65 inches)
Weight:	1 kg

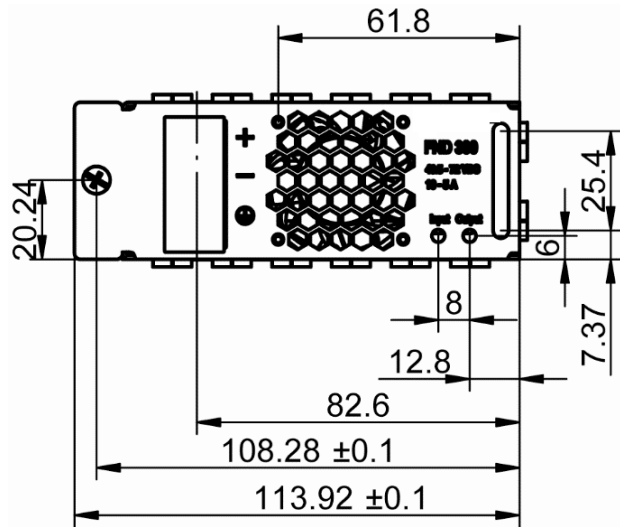

Figure 3 - Front View

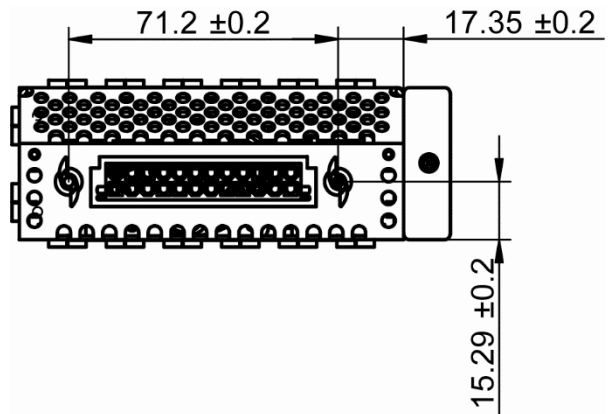

Figure 4 - Rear View

FND300-1012G

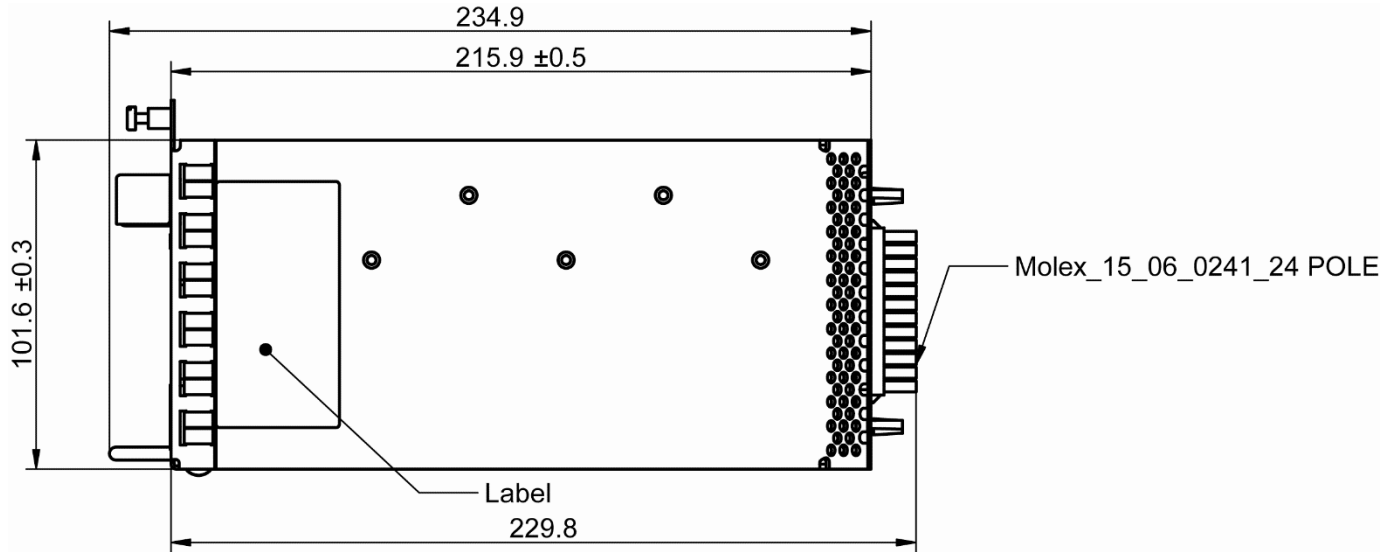

Figure 5 - Top View

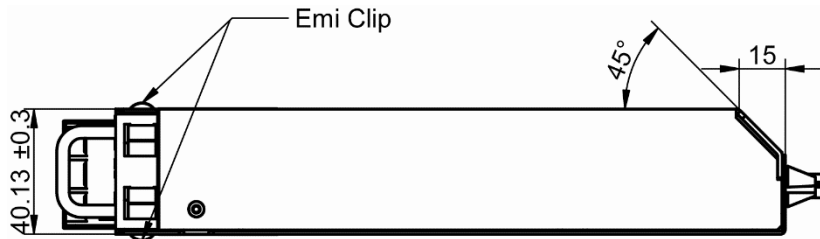

Figure 6 - Side View

For more information on these products consult: tech.support@psbel.com

NUCLEAR AND MEDICAL APPLICATIONS - Products are not designed or intended for use as critical components in life support systems, equipment used in hazardous environments, or nuclear control systems.

TECHNICAL REVISIONS - The appearance of products, including safety agency certifications pictured on labels, may change depending on the date manufactured. Specifications are subject to change without notice.



Компания «ЭлектроПласт» предлагает заключение долгосрочных отношений при поставках импортных электронных компонентов на взаимовыгодных условиях!

Наши преимущества:

- Оперативные поставки широкого спектра электронных компонентов отечественного и импортного производства напрямую от производителей и с крупнейших мировых складов;
- Поставка более 17-ти миллионов наименований электронных компонентов;
- Поставка сложных, дефицитных, либо снятых с производства позиций;
- Оперативные сроки поставки под заказ (от 5 рабочих дней);
- Экспресс доставка в любую точку России;
- Техническая поддержка проекта, помощь в подборе аналогов, поставка прототипов;
- Система менеджмента качества сертифицирована по Международному стандарту ISO 9001;
- Лицензия ФСБ на осуществление работ с использованием сведений, составляющих государственную тайну;
- Поставка специализированных компонентов (Xilinx, Altera, Analog Devices, Intersil, Interpoint, Microsemi, Aeroflex, Peregrine, Syfer, Eurofarad, Texas Instrument, Miteq, Cobham, E2V, MA-COM, Hittite, Mini-Circuits, General Dynamics и др.);

Помимо этого, одним из направлений компании «ЭлектроПласт» является направление «Источники питания». Мы предлагаем Вам помощь Конструкторского отдела:

- Подбор оптимального решения, техническое обоснование при выборе компонента;
- Подбор аналогов;
- Консультации по применению компонента;
- Поставка образцов и прототипов;
- Техническая поддержка проекта;
- Защита от снятия компонента с производства.



Как с нами связаться

Телефон: 8 (812) 309 58 32 (многоканальный)

Факс: 8 (812) 320-02-42

Электронная почта: org@eplast1.ru

Адрес: 198099, г. Санкт-Петербург, ул. Калинина, дом 2, корпус 4, литера А.