

Features

- Gain: 24.5 dB
- P_{-1dB} : 29 dBm
- P_{SAT} : 30 dBm
- PAE at P_{SAT} : 40%
- OIP3: 40 dBm
- Typical bias conditions: 9 V, 265 mA
- Fully matched output
- Lead-Free 3 mm 16-LD PQFN package
- Halogen-Free “Green” Mold Compound
- RoHS* Compliant

Description

The MAAP-011232 is a 2-stage power amplifier with gain shut off, operating from 100 MHz to 3 GHz. For operation in the 100 MHz to 1 GHz frequency range no I/O matching is required. Internal DC blocking is provided at the input, while the RF output port is DC coupled through an external bias-tee. Bias current, RF gain and output power are controlled with a gate bias voltage (V_G). Typical current consumption is less than 300 mA at maximum output power.

The MAAP-011232 is well suited to both power and driver requirements for multiple applications such as LMR, Milcom, Sensors & Telemetry, Test & Measurement and Satcom.

The MAAP-011232 is fabricated using a GaAs D-mode high breakdown process which features full passivation for increased performance and reliability.

Ordering Information^{1,2}

Part Number	Package
MAAP-011232	Bulk
MAAP-011232-TR0500	500 Piece Reel
MAAP-011232-TR1000	1000 Piece Reel
MAAP-011232-001SMB	Sample Board Type A
MAAP-011232-002SMB	Sample Board Type B

1. Reference Application Note M513 for reel size information.
2. All sample boards include 5 loose parts.

* Restrictions on Hazardous Substances, European Union Directive 2011/65/EU.

Functional Schematic

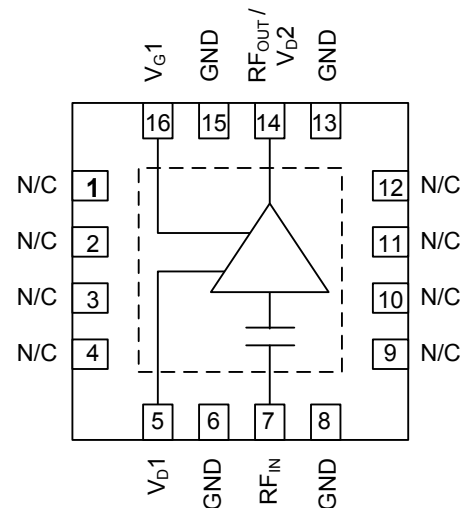

Pin Configuration^{3,4}

Pin No.	Function
1 - 4	No Connection
5	Drain Voltage V_{D1}
6	Ground
7	RF Input
8	Ground
9 - 12	No Connection
13	Ground
14	RF Output and Drain Voltage V_{D2}
15	Ground
16	Shut Off Voltage V_G

3. MACOM recommends connecting unused package pins to ground.
4. The exposed pad centered on the package bottom must be connected to RF, DC and thermal ground.

1 W Driver Amplifier with VG Enable 0.1 - 3.0 GHz

Rev. V2

Electrical Specifications:

Freq. = 1 GHz, $T_A = +25^\circ\text{C}$, $V_{D1} = V_{D2} = 9\text{ V}$, $I_{DQ2} = 200\text{ mA}$, $Z_0 = 50\ \Omega$, V_G pulsed with 1 ms pulse width and 10% duty cycle

Parameter	Symbol	Test Conditions	Units	Min.	Typ.	Max.
Small-Signal Gain	SSG	-10 dBm input drive level	dB	23	24.5	—
Output Power at 1dB compression	$P_{-1\text{dB}}$	—	dBm	—	29	—
Saturated Output Power	P_{SAT}	3 dB Gain compression	dBm	28.5	30	—
Power Added Efficiency	PAE	3 dB Gain compression	%	35	40	—
Reverse Isolation	S12	-10 dBm input drive level	dB	—	50	—
Input Return Loss	IRL	-10 dBm input drive level	dB	—	8	—
Output Return Loss	ORL	-10 dBm input drive level	dB	—	12	—
Output Third Order Intercept	OIP3	-13 dBm/tone, F1-F2 = 6 MHz	dBm	—	40	—
Gate Bias Voltage	V_G	—	V	—	-0.55	—
Quiescent Drain Current	I_{DQ1}	—	mA	—	65	—

Schematic of the Production Test Board

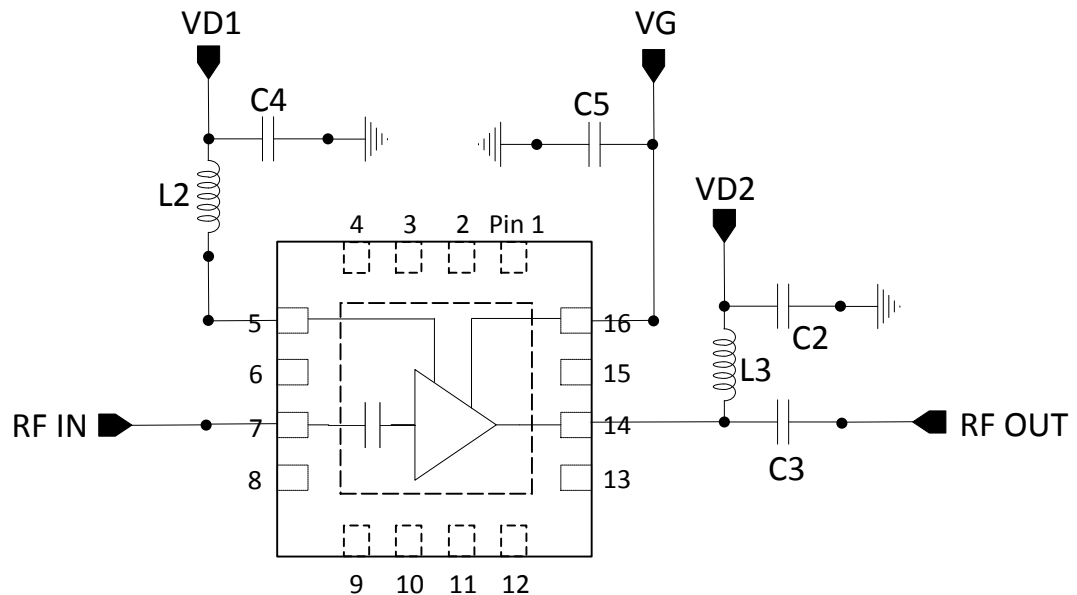

Absolute Maximum Ratings^{5,6}

Parameter	Absolute Maximum
RF Input Power	20 dBm
Gate Voltage	-4 V to 0 V
Drain Voltage VD1	10 V
Drain Voltage VD2	10 V
Junction Temperature ^{7,8}	+150°C
Operating Temperature	-40°C to +85°C
Storage Temperature	-55°C to +150°C

5. Exceeding any one or combination of these limits may cause permanent damage to this device.
6. MACOM does not recommend sustained operation near these survivability limits.
7. Operating at nominal conditions with $T_J \leq +150^\circ\text{C}$ will ensure $\text{MTTF} > 1 \times 10^6$ hours.
8. Junction Temperature (T_J) = $T_C + \Theta_{JC} * [(V * I) - (P_{OUT} - P_{IN})]$
 Typical thermal resistance (Θ_{JC}) = 29°C/W.

Handling Procedures

Please observe the following precautions to avoid damage:

Static Sensitivity

These electronic devices are sensitive to electrostatic discharge (ESD) and can be damaged by static electricity. Proper ESD control techniques should be used when handling these (HBM) Class 1A devices.

Operating the MAAP-011232

To operate the device, follow these steps:

1. Set VG to -2 V.
2. Turn on VD1 and VD2 to 5-9 V.
3. Adjust VG to set I_{DQ2} (I_{DQ1} varies).
4. Turn off in reverse order with VG last.

1 W Driver Amplifier with VG Enable 0.1 - 3.0 GHz

Rev. V2

Typical Electrical Specifications: Test Board A: 100 - 1600 MHz Input Tuning

$T_A = +25^\circ\text{C}$, $V_{D1} = V_{D2} = 9\text{ V}$, $I_{DQ2} = 200\text{ mA}$, $Z_0 = 50\ \Omega$, CW

Parameter	Sym-	Test Conditions	Units	Typical Values			
Frequency	F	—	MHz	100	700	1100	1600
Small-Signal Gain	SSG	-10 dBm input drive level	dB	16	26	25	21
Output Power at 1dB compression	$P_{-1\text{dB}}$	1 dB Gain compression	dBm	29	29	30	29
Saturated Output Power	P_{SAT}	3 dB Gain compression	dBm	30	30	30.5	30
Power Added Efficiency	PAE	3 dB Gain compression	%	32	40	45	37
Reverse Isolation	S12	-10 dBm input drive level	dB	79	56	55	53
Input Return Loss	IRL	-10 dBm input drive level	dB	4	17	28	7
Output Return Loss	ORL	-10 dBm input drive level	dB	17	16	15	14
Output Third Order Intercept	OIP3	-13 dBm/tone, F1-F2 = 6 MHz	dBm	41	44	43	40
Gate Bias Voltage	V_G	—	V	-0.55			
Quiescent Drain Current	I_{DQ1}	—	mA	65			

Schematic of the Test Board Type A: 100-1600 MHz Input Tuning

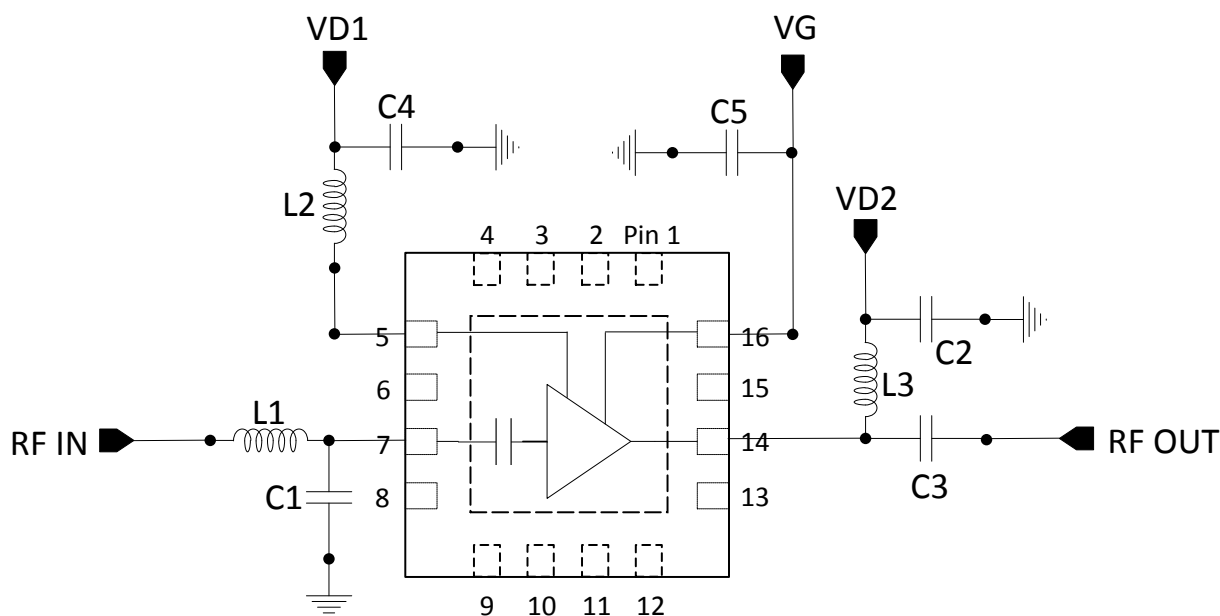

Test Board Type A: 100 - 1600 MHz Input Tuning

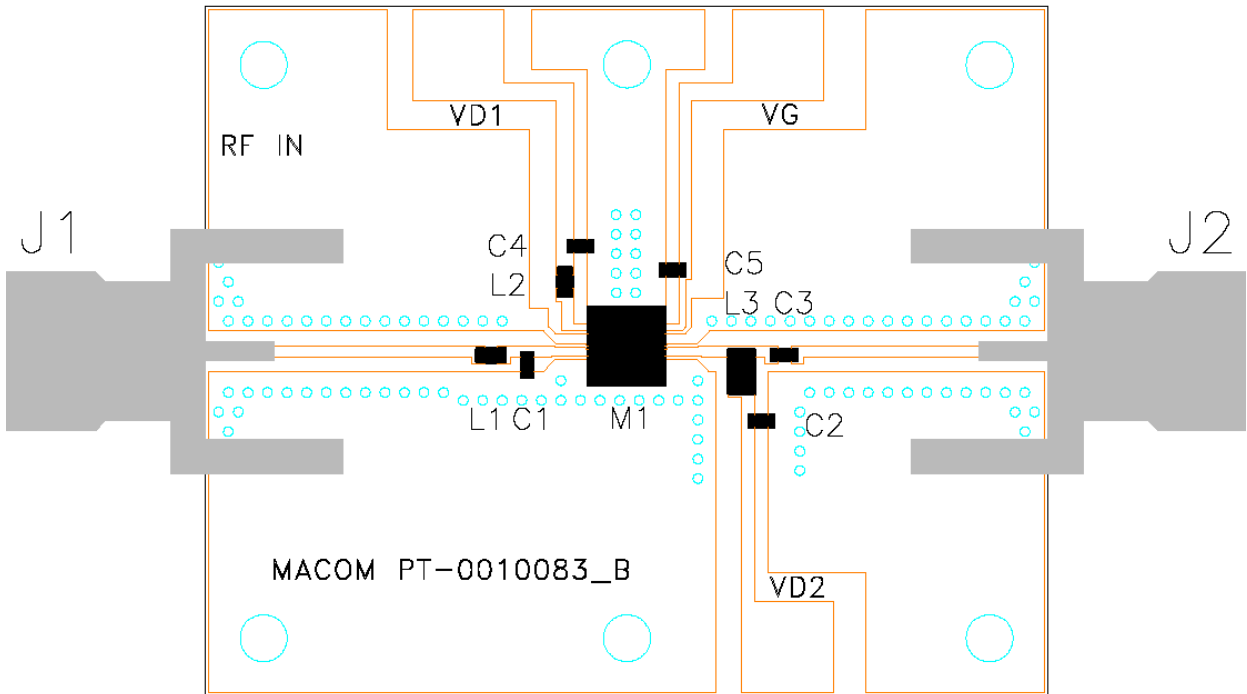

PCB Material: R4003C LoPro, 0.008" THICK, Solid Copper filled vias

Parts List

Part	Description	Value	Size	Manufacturer
C1	Capacitor	0.6 pF	0402	Murata
C2, C4	Capacitor	0.1 μ F	0402	Murata
C3	Capacitor	100 pF	0402	Murata
C5	Capacitor	10 nF	0402	Murata
L1	Inductor	7.5 nH	0402	0402CS, Coilcraft
L2	Inductor	560 nH	0402	0402AF, Coilcraft
L3	Inductor	110 nH	0603	0603HP, Coilcraft
J1, J2	SMA Connector	—	—	142-0701-881 Emerson

Test Board Type A: S-parameters over Temperature

Test Conditions: $T_A = +25^\circ\text{C}$, $V_{D1} = V_{D2} = 9\text{ V}$, $I_{DQ1} = 65\text{ mA}$, $I_{DQ2} = 200\text{ mA}$, $Z_0 = 50\ \Omega$, CW

Insertion Gain vs. Frequency

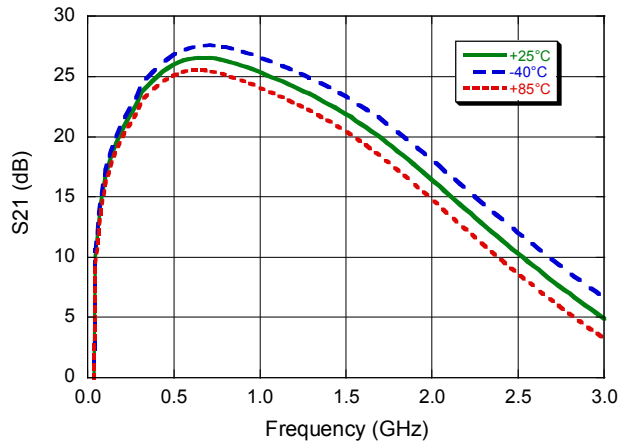

Isolation vs. Frequency

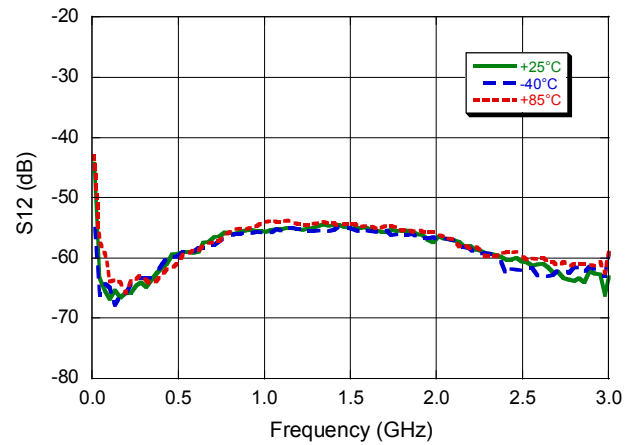

Input Return Loss vs. Frequency

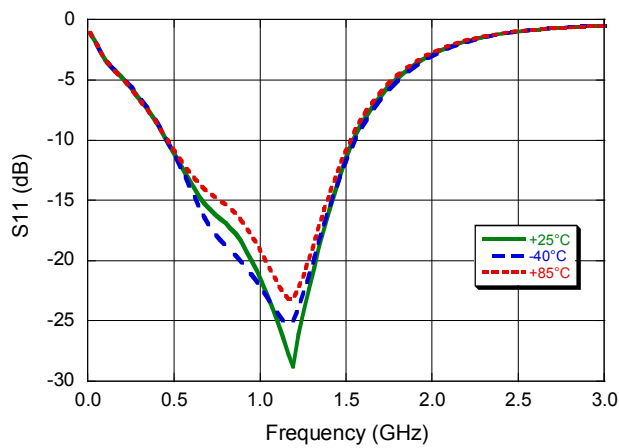

Output Return Loss vs. Frequency

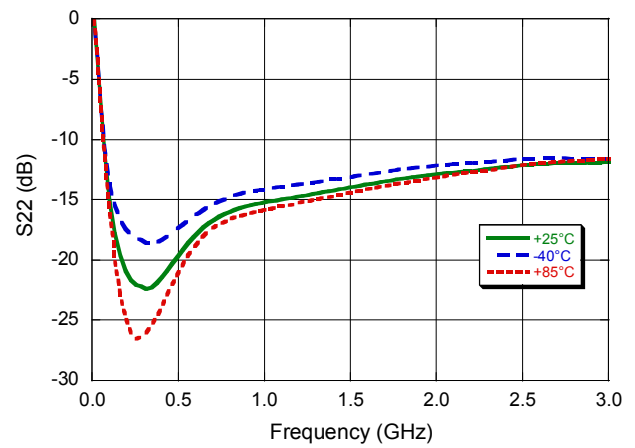

1 W Driver Amplifier with VG Enable 0.1 - 3.0 GHz

Rev. V2

Test Board Type A - Power Performance @ Room Temperature

Test Conditions: $T_A = +25^\circ\text{C}$, $V_{D1} = V_{D2} = 9\text{ V}$, $I_{DQ1} = 65\text{ mA}$, $I_{DQ2} = 200\text{ mA}$, $Z_0 = 50\ \Omega$, CW

P_{OUT} , Gain and Efficiency vs. P_{IN} @ 700 MHz

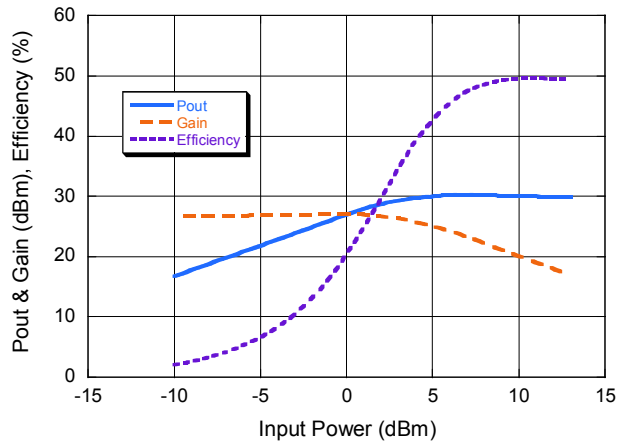

Bias Current vs. P_{IN} @ 700 MHz

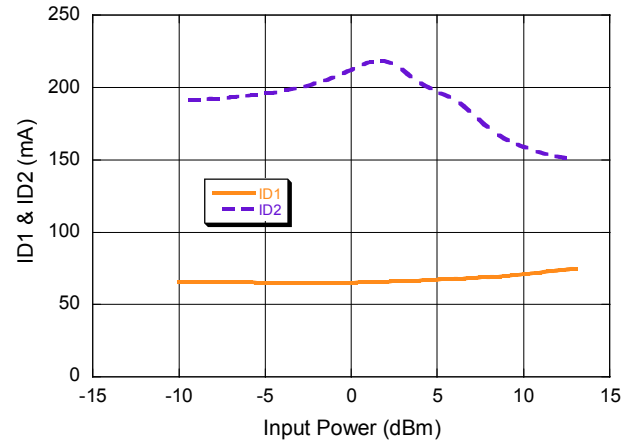

P_{OUT} , Gain and Efficiency vs. P_{IN} @ 1100 MHz

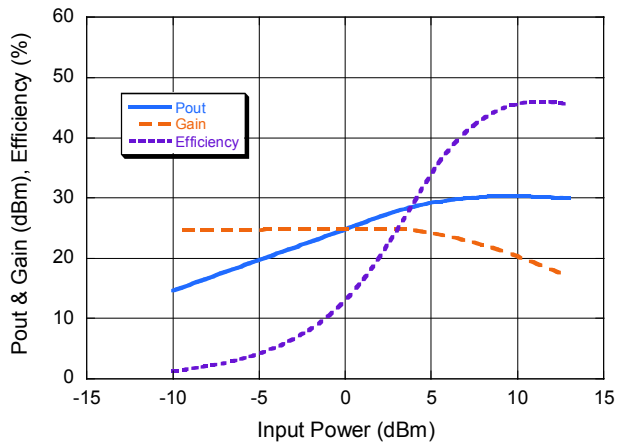

Bias Current vs. P_{IN} @ 1100 MHz

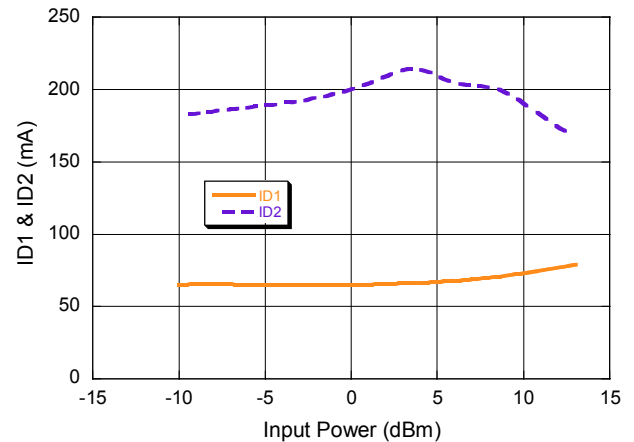

P_{OUT} , Gain and Efficiency vs. P_{IN} @ 1600 MHz

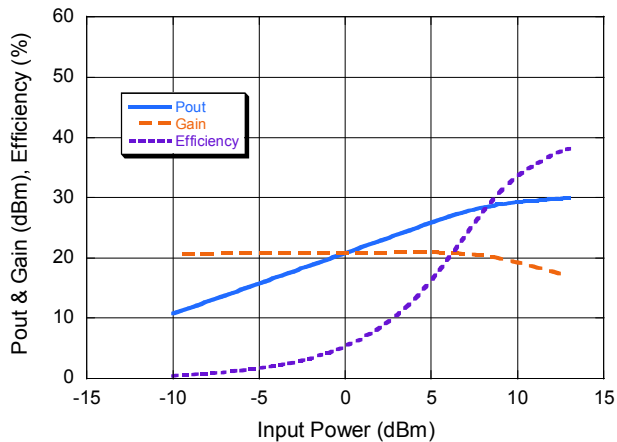

Bias Current vs. P_{IN} @ 1600 MHz

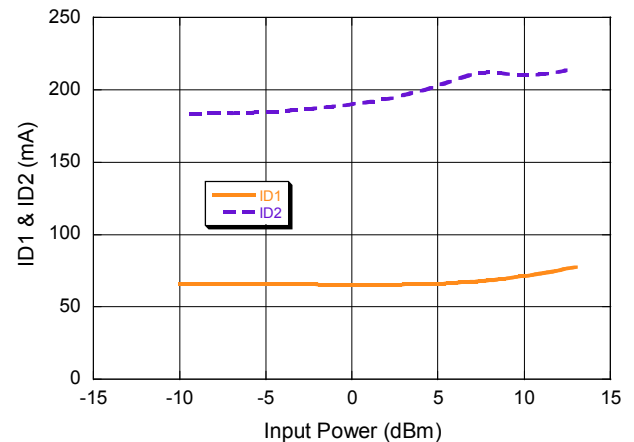

1 W Driver Amplifier with VG Enable 0.1 - 3.0 GHz

Rev. V2

Test Board Type A - Power Performance over Temperature

Test Conditions: $T_A = +25^\circ\text{C}$, $V_{D1} = V_{D2} = 9\text{ V}$, $I_{DQ1} = 65\text{ mA}$, $I_{DQ2} = 200\text{ mA}$, $Z_0 = 50\ \Omega$, CW

Saturated Power vs. Frequency

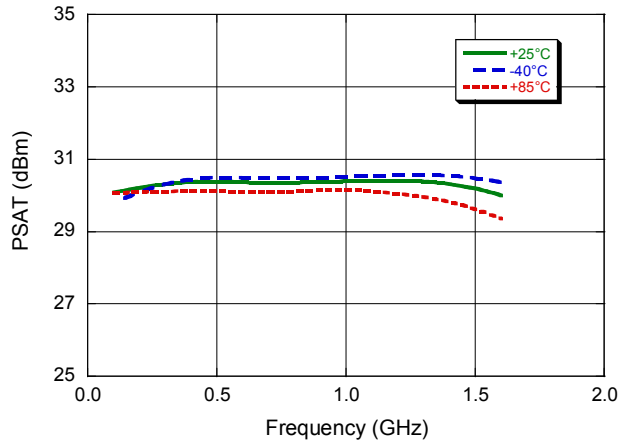

P1dB vs. Frequency

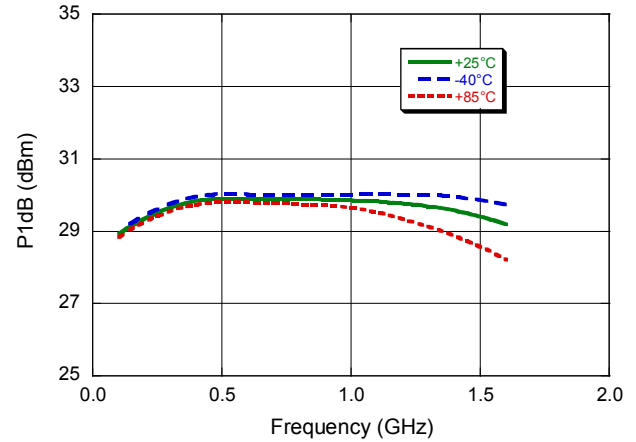

PAE vs. Frequency

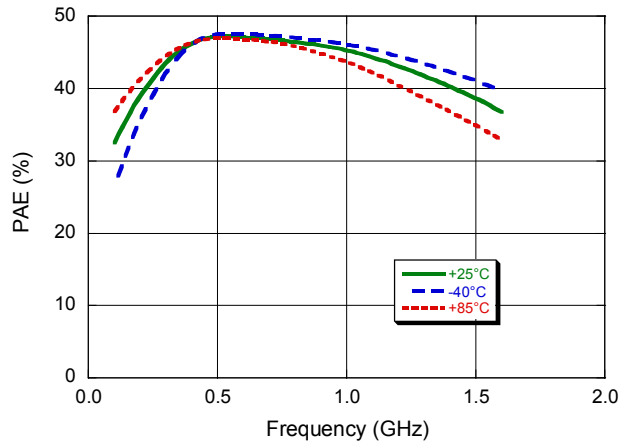

Output IP3 vs. Frequency

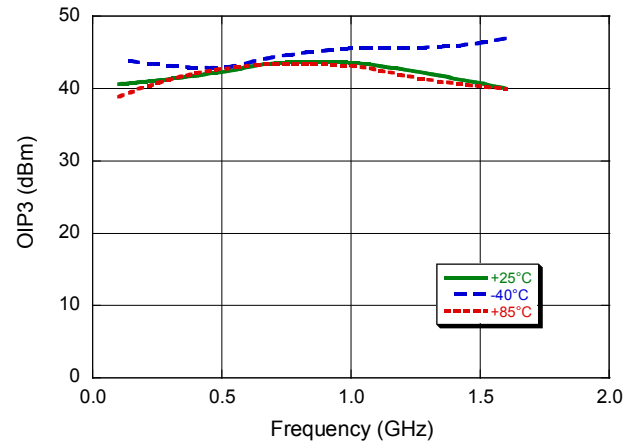

Gain Control Range vs. Frequency

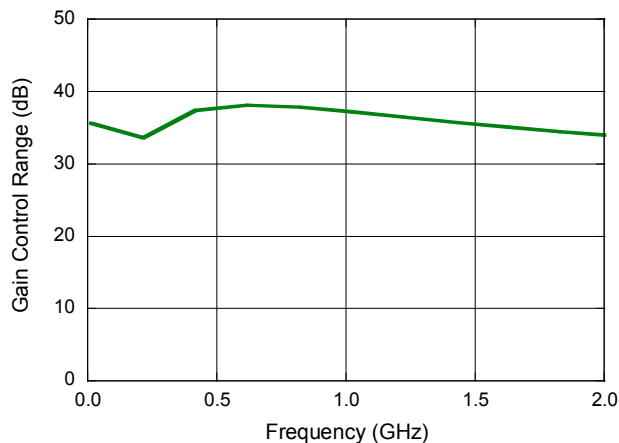

$P_{IN} = -13\text{ dBm/tone}$, tone separation = 6 MHz

Measured for V_G between -0.4 V and -1.4 V

1 W Driver Amplifier with VG Enable 0.1 - 3.0 GHz

Rev. V2

Typical Electrical Specifications: Test Board B: 1600 - 3000 MHz Input Tuning

$T_A = +25^\circ\text{C}$, $V_{D1} = V_{D2} = 9\text{ V}$, $I_{DQ2} = 200\text{ mA}$, $Z_0 = 50\ \Omega$, CW

Parameter	Symbol	Test Conditions	Units	Typical Values		
Frequency	F	—	MHz	2000	2500	3000
Small-Signal Gain	SSG	-10 dBm input drive level	dB	24	24	17
Output Power @ 1dB compression	$P_{-1\text{dB}}$	1 dB Gain compression	dBm	29	29	30
Saturated Output Power	P_{SAT}	3 dB Gain compression	dBm	30	30	30.5
Power Added Efficiency	PAE	3 dB Gain compression	%	37	40.5	37
Reverse Isolation	S12	-10 dBm input drive level	dB	51	52	54
Input Return Loss	IRL	-10 dBm input drive level	dB	9	11	2
Output Return Loss	ORL	-10 dBm input drive level	dB	10	9	9
Output Third Order Intercept	OIP3	-13 dBm/tone, F1-F2 = 6 MHz	dBm	40	42	40
Gate Bias Voltage	V_G	—	V	-0.55		
Quiescent Drain Current	I_{DQ1}	—	mA	65		

Schematic of the Test Board Type B: 1600-3000 MHz Input Tuning

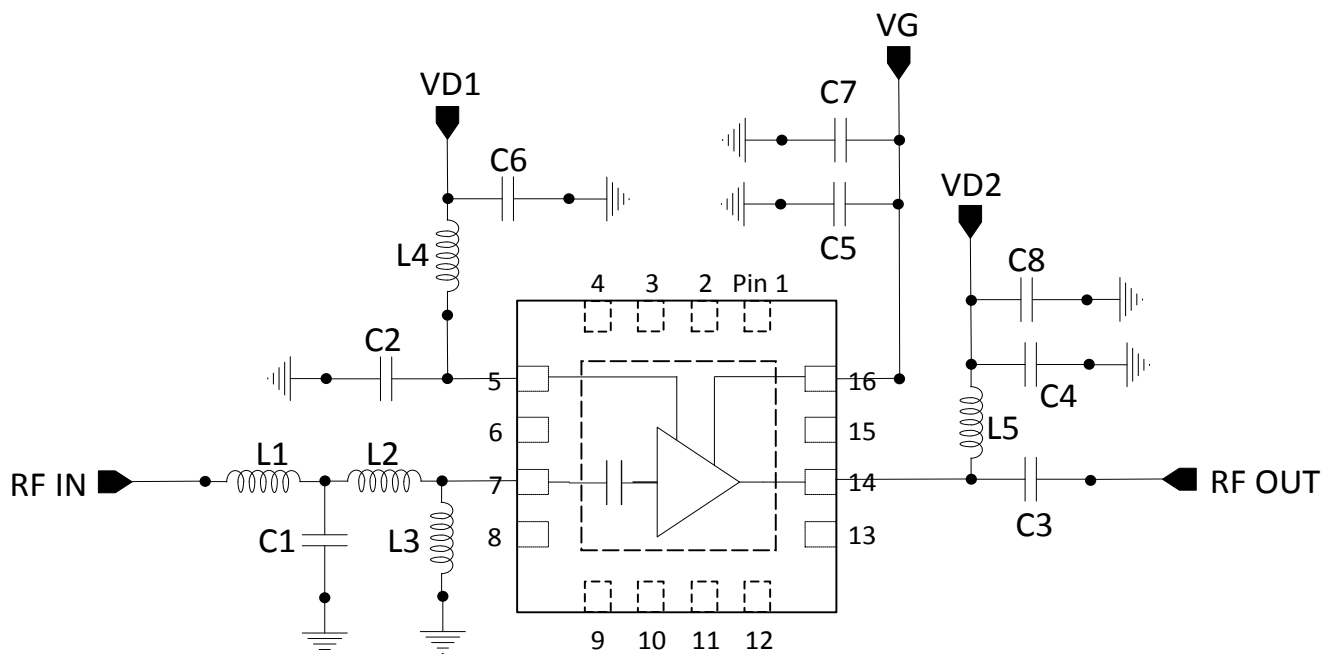

Test Board Type B: 1600 - 3000 MHz Input Tuning

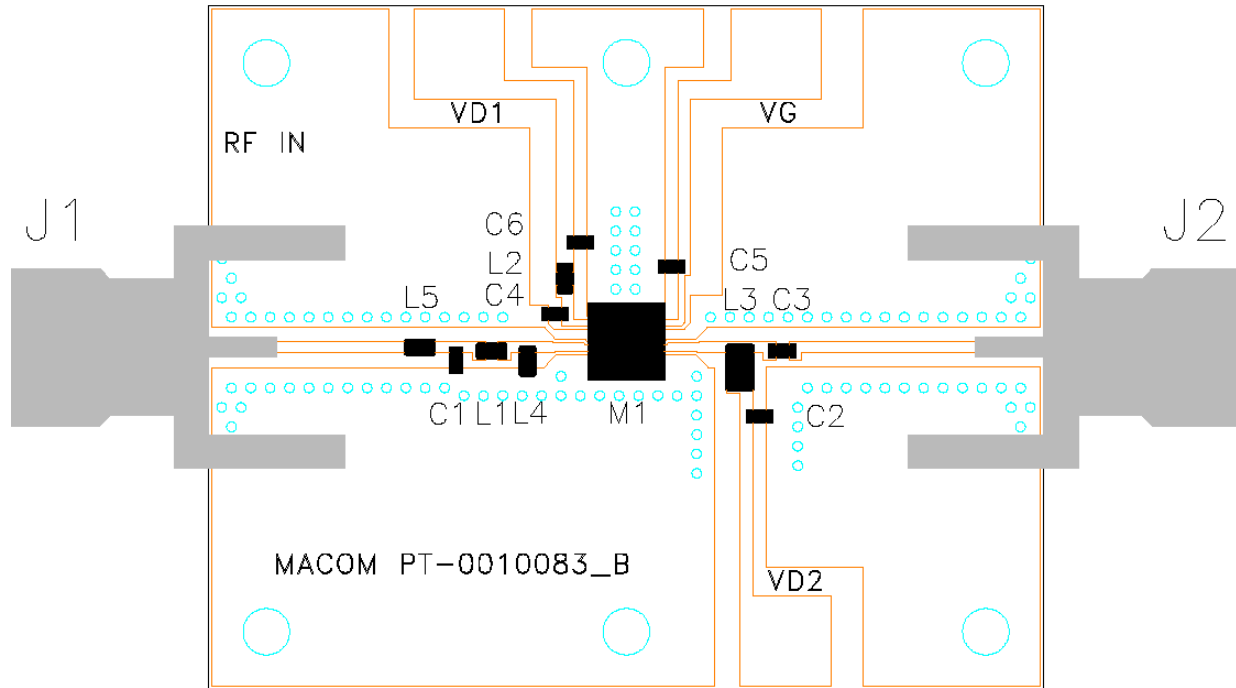

PCB Material: R4003C LoPro, 0.008" THICK, Solid Copper filled vias

Parts List

Part	Description	Value	Size	Manufacturer
C1	Capacitor	1.2 pF	0402	PPI
C4, C5	Capacitor	10 nF	0402	Murata
C2, C6	Capacitor	0.1 μ F	0402	Murata
C3	Capacitor	100 pF	0402	Murata
L1	Inductor	5.6 nH	0402	0402HP, Coilcraft
L2	Inductor	560 nH	0402	0402AF, Coilcraft
L3	Inductor	110 nH	0603	0603HP, Coilcraft
L4	Inductor	10 nH	0402	0402HP, Coilcraft
L5	Inductor	3.3 nH	0402	0402HP, Coilcraft
J1, J2	SMA Connector	—	—	142-0701-881 Emerson

Test Board Type B: S-parameters over Temperature

Test Conditions: $T_A = +25^\circ\text{C}$, $V_{D1} = V_{D2} = 9\text{ V}$, $I_{DQ1} = 65\text{ mA}$, $I_{DQ2} = 200\text{ mA}$, $Z_0 = 50\ \Omega$, CW

Insertion Gain vs. Frequency

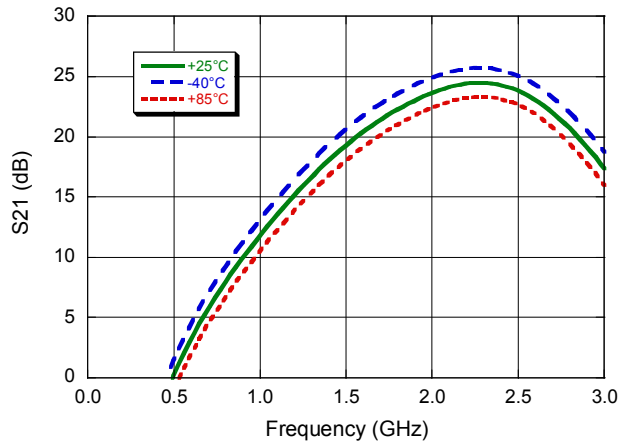

Isolation vs. Frequency

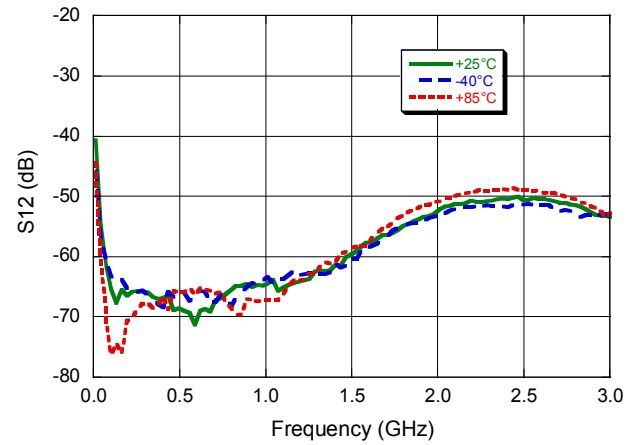

Input Return Loss vs. Frequency

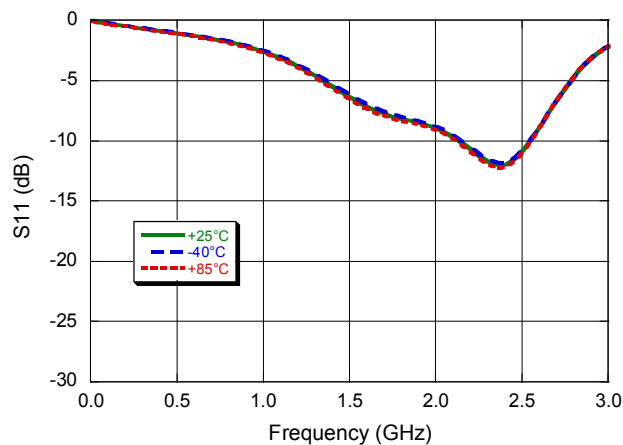

Output Return Loss vs. Frequency

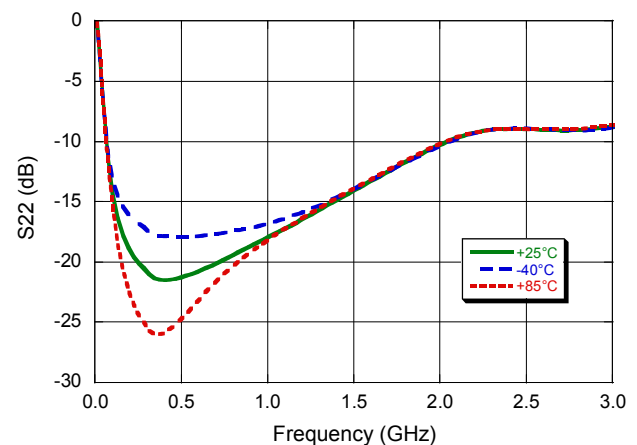

1 W Driver Amplifier with VG Enable 0.1 - 3.0 GHz

Rev. V2

Test Board Type B - Power Performance @ Room Temperature

Test Conditions: $T_A = +25^\circ\text{C}$, $V_{D1} = V_{D2} = 9\text{ V}$, $I_{DQ1} = 65\text{ mA}$, $I_{DQ2} = 200\text{ mA}$, $Z_0 = 50\ \Omega$, CW

P_{OUT} , Gain and Efficiency vs. P_{IN} @ 2 GHz

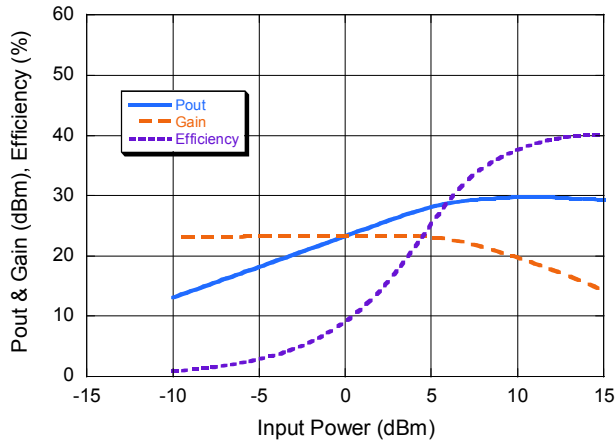

Bias Current vs. P_{IN} @ 2 GHz

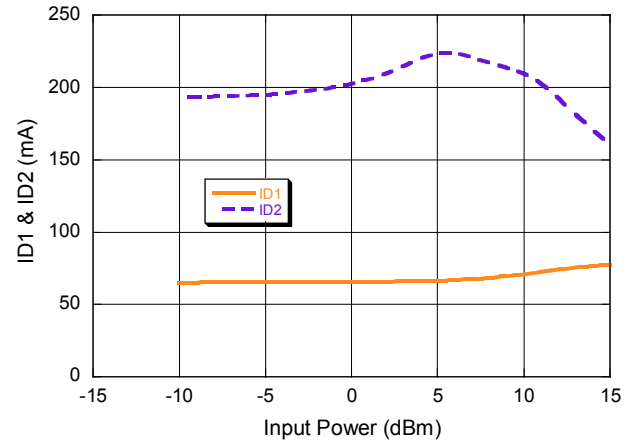

P_{OUT} , Gain and Efficiency vs. P_{IN} @ 2.5 GHz

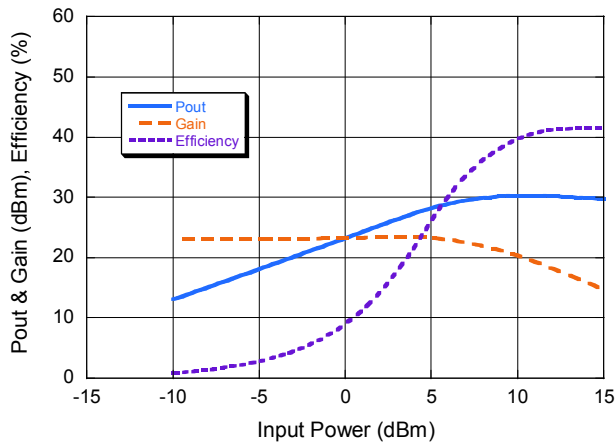

Bias Current vs. P_{IN} @ 2.5 GHz

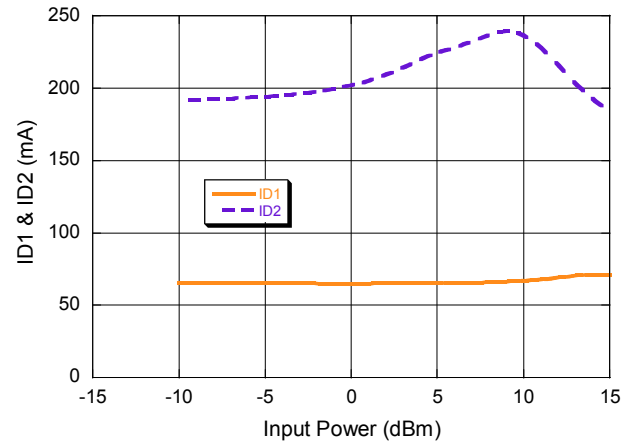

P_{OUT} , Gain and Efficiency vs. P_{IN} @ 3 GHz

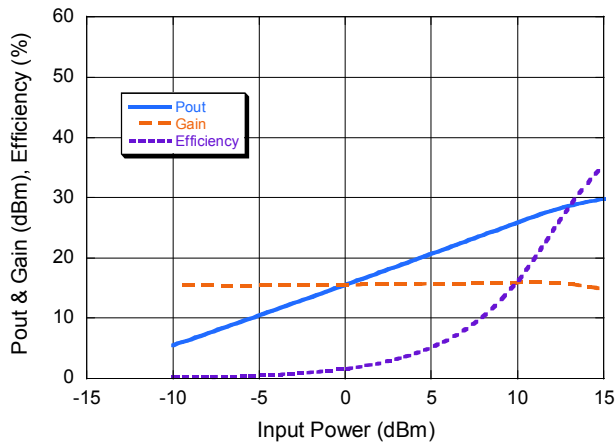

Bias Current vs. P_{IN} @ 3 GHz

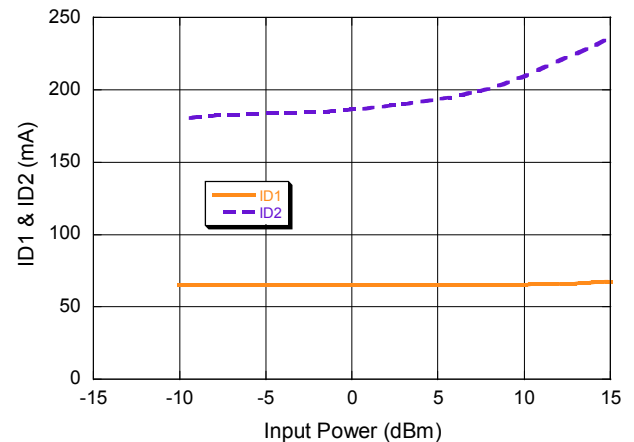

1 W Driver Amplifier with VG Enable 0.1 - 3.0 GHz

Rev. V2

Test Board Type B - Power Performance over Temperature

Test Conditions: $T_A = +25^\circ\text{C}$, $V_{D1} = V_{D2} = 9\text{ V}$, $I_{DQ1} = 65\text{ mA}$, $I_{DQ2} = 200\text{ mA}$, $Z_0 = 50\ \Omega$, CW

Saturated Power vs. Frequency

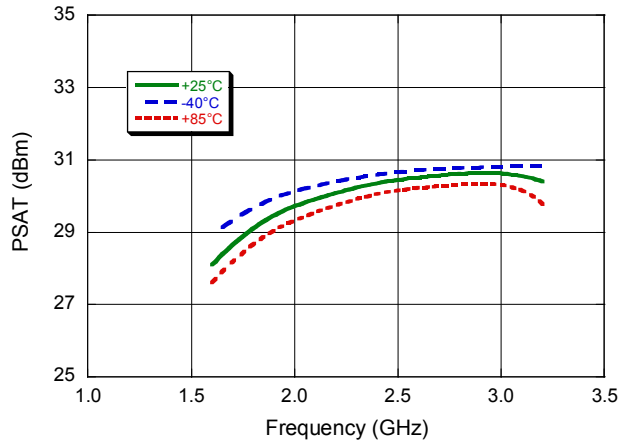

P1dB vs. Frequency

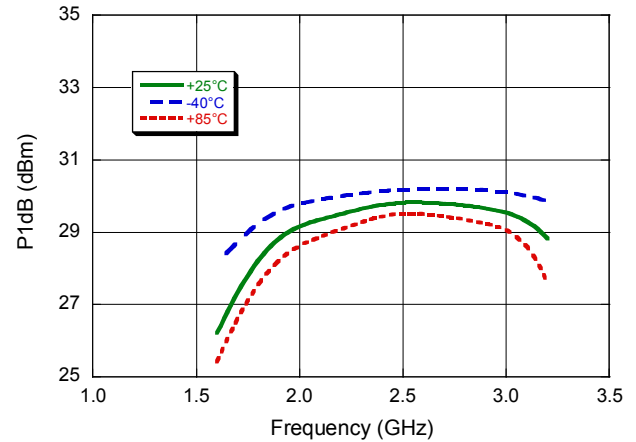

PAE vs. Frequency

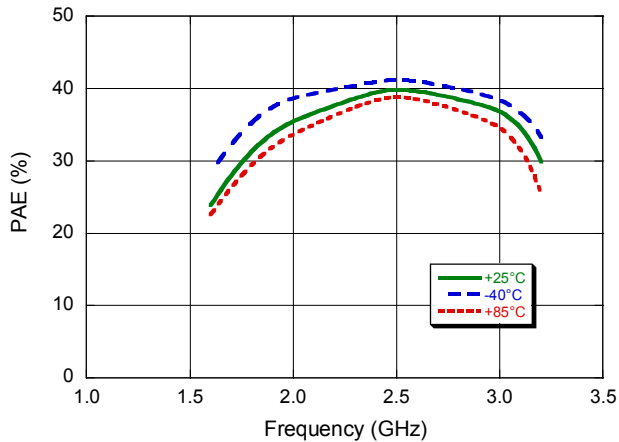

Output IP3 vs. Frequency

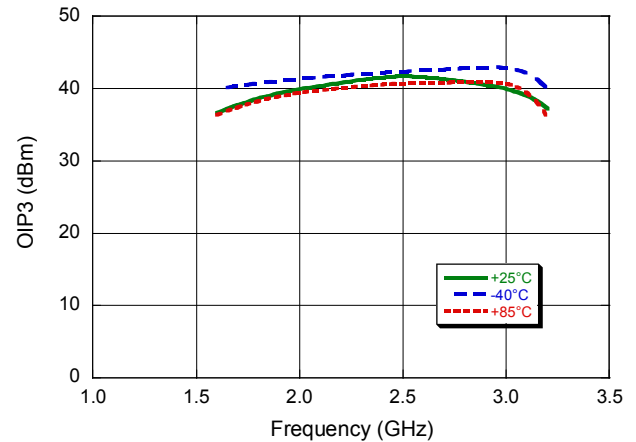

Gain Control Range vs. Frequency

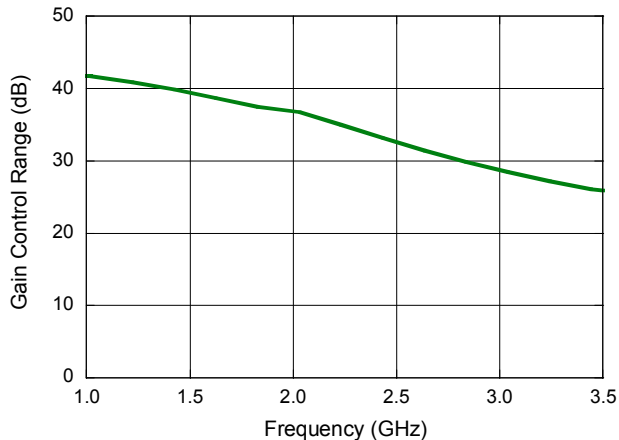

$P_{IN} = -13\text{ dBm/ tone}$, tone separation = 6 MHz

Measured for V_G between -0.4 V and -1.4 V

Recommended Landing Pattern ^{9,10}

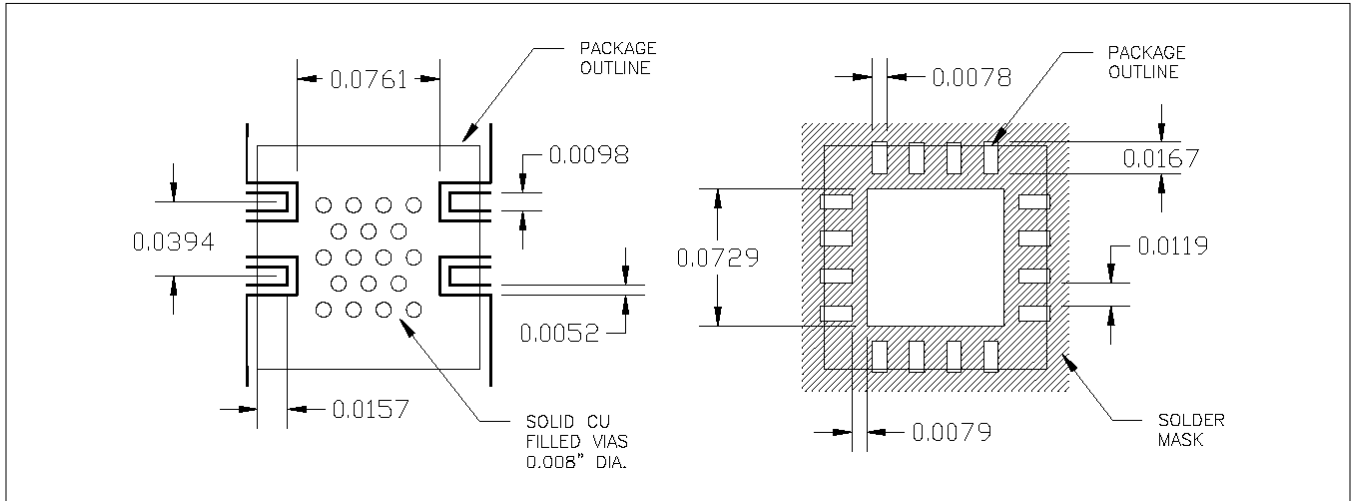

9. All dimensions are in inches.
10. Landing pattern indicates solder mask opening. Cu-filled via-holes under the ground are used for optimal thermal performance. Recommended pattern: 8-mil diameter, 8-mil spacing.

Lead-Free 3 mm 16-Lead PQFN[†]

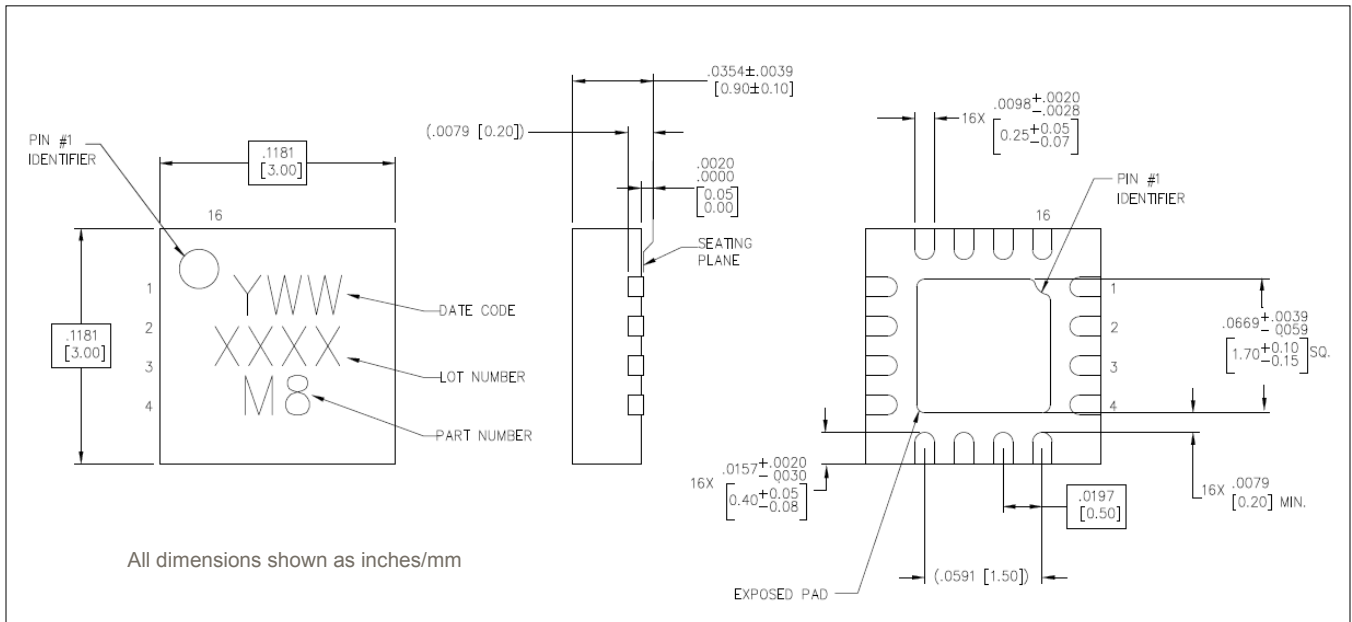

[†] Reference Application Note M538 for lead-free solder reflow recommendations.
 Meets JEDEC moisture sensitivity level 1 requirements.
 Plating is 100% matte tin over copper.

MACOM Technology Solutions Inc. All rights reserved.

Information in this document is provided in connection with MACOM Technology Solutions Inc ("MACOM") products. These materials are provided by MACOM as a service to its customers and may be used for informational purposes only. Except as provided in MACOM's Terms and Conditions of Sale for such products or in any separate agreement related to this document, MACOM assumes no liability whatsoever. MACOM assumes no responsibility for errors or omissions in these materials. MACOM may make changes to specifications and product descriptions at any time, without notice. MACOM makes no commitment to update the information and shall have no responsibility whatsoever for conflicts or incompatibilities arising from future changes to its specifications and product descriptions. No license, express or implied, by estoppel or otherwise, to any intellectual property rights is granted by this document.

THESE MATERIALS ARE PROVIDED "AS IS" WITHOUT WARRANTY OF ANY KIND, EITHER EXPRESS OR IMPLIED, RELATING TO SALE AND/OR USE OF MACOM PRODUCTS INCLUDING LIABILITY OR WARRANTIES RELATING TO FITNESS FOR A PARTICULAR PURPOSE, CONSEQUENTIAL OR INCIDENTAL DAMAGES, MERCHANTABILITY, OR INFRINGEMENT OF ANY PATENT, COPYRIGHT OR OTHER INTELLECTUAL PROPERTY RIGHT. MACOM FURTHER DOES NOT WARRANT THE ACCURACY OR COMPLETENESS OF THE INFORMATION, TEXT, GRAPHICS OR OTHER ITEMS CONTAINED WITHIN THESE MATERIALS. MACOM SHALL NOT BE LIABLE FOR ANY SPECIAL, INDIRECT, INCIDENTAL, OR CONSEQUENTIAL DAMAGES, INCLUDING WITHOUT LIMITATION, LOST REVENUES OR LOST PROFITS, WHICH MAY RESULT FROM THE USE OF THESE MATERIALS.

MACOM products are not intended for use in medical, lifesaving or life sustaining applications. MACOM customers using or selling MACOM products for use in such applications do so at their own risk and agree to fully indemnify MACOM for any damages resulting from such improper use or sale.



Компания «ЭлектроПласт» предлагает заключение долгосрочных отношений при поставках импортных электронных компонентов на взаимовыгодных условиях!

Наши преимущества:

- Оперативные поставки широкого спектра электронных компонентов отечественного и импортного производства напрямую от производителей и с крупнейших мировых складов;
- Поставка более 17-ти миллионов наименований электронных компонентов;
- Поставка сложных, дефицитных, либо снятых с производства позиций;
- Оперативные сроки поставки под заказ (от 5 рабочих дней);
- Экспресс доставка в любую точку России;
- Техническая поддержка проекта, помощь в подборе аналогов, поставка прототипов;
- Система менеджмента качества сертифицирована по Международному стандарту ISO 9001;
- Лицензия ФСБ на осуществление работ с использованием сведений, составляющих государственную тайну;
- Поставка специализированных компонентов (Xilinx, Altera, Analog Devices, Intersil, Interpoint, Microsemi, Aeroflex, Peregrine, Syfer, Eurofarad, Texas Instrument, Miteq, Cobham, E2V, MA-COM, Hittite, Mini-Circuits, General Dynamics и др.);

Помимо этого, одним из направлений компании «ЭлектроПласт» является направление «Источники питания». Мы предлагаем Вам помощь Конструкторского отдела:

- Подбор оптимального решения, техническое обоснование при выборе компонента;
- Подбор аналогов;
- Консультации по применению компонента;
- Поставка образцов и прототипов;
- Техническая поддержка проекта;
- Защита от снятия компонента с производства.



Как с нами связаться

Телефон: 8 (812) 309 58 32 (многоканальный)

Факс: 8 (812) 320-02-42

Электронная почта: org@eplast1.ru

Адрес: 198099, г. Санкт-Петербург, ул. Калинина, дом 2, корпус 4, литера А.