

**Harvatek Surface Mount LED Data Sheet
HT-110 Series**

Official Product	Product: HT-110 Series			Data Sheet No.
Tentative Product	*****			HT-110 Series
Specifications are subject to change without notice. Data and drawings herein are copyrighted.		Mar. 03, 2005	Version of 1.0	Page 1/25

DISCLAIMER	3
PRODUCT SPECIFICATIONS	4
ATTENTION: ELECTROSTATIC DISCHARGE (ESD) PROTECTION	5
LABEL SPECIFICATIONS	6
PRODUCT CHARACTERISTICS	11
ABSOLUTE MAXIMUM RATINGS	11
ELECTRO-OPTICAL CHARACTERISTICS	12
PACKAGE OUTLINE DIMENSION	13
RECOMMENDED SOLDERING PATTERN FOR REFLOW SOLDERING	13
CHARACTERISTIC CURVES FOR YG, Y, D, SD AND UR	14
CHARACTERISTIC CURVES FOR UYG, UY, UD AND USD	15
CHARACTERISTIC CURVES FOR NB, NG AND TW	16
CHARACTERISTIC CURVES FOR ALL COLORS (RADIATION PATTERN)	17
PACKAGING	18
TAPE DIMENSION	18
REEL DIMENSION	19
PACKING	20
DRY PACK	21
REFLOW SOLDERING	22
WAVE SOLDERING	23
PRECAUTIONS	23
REWORKING	23
CLEANING	23
RELIABILITY	24
REVISION HISTORY	25

Official Product	Product: HT-110 Series			Data Sheet No.
Tentative Product	*****			HT-110 Series
Specifications are subject to change without notice. Data and drawings herein are copyrighted.	Mar. 03, 2005	Version of 1.0	Page 2/25	

DISCLAIMER

HARVATEK reserves the right to make changes without further notice to any products herein to improve reliability, function or design. HARVATEK does not assume any liability arising out of the application or use of any product or circuit described herein; neither does it convey any license under its patent rights, nor the rights of others.

LIFE SUPPORT POLICY

HARVATEK's products are not authorized for use as critical components in life support devices or systems without the express written approval of the President of HARVATEK or HARVATEK INTERNATIONAL. As used herein:

1. Life support devices or systems are devices or systems which, (a) are intended for surgical implant into the body, or (b) support or sustain life, and (c) whose failure to perform when properly used in accordance with instructions for use provided in the labeling, can be reasonably expected to result in a significant injury of the user.
2. A critical component in any component of a life support device or system whose failure to perform can be reasonably expected to cause the failure of the life support device or system, or to affect its safety or effectiveness.

Official Product	Product: HT-110 Series			Data Sheet No.
Tentative Product	*****			HT-110 Series
Specifications are subject to change without notice. Data and drawings herein are copyrighted.		Mar. 03, 2005	Version of 1.0	Page 3/25

Product Specifications

Product	Emission Color	Technology	Test Current I_F (mA)	Luminous Intensity I_V (mcd)	Forward Voltage V_F (V)	Orderable Part Number
HT-110YG	Yellow Green	GaP	20	16 typ	2.2 typ	HT-110YG-YYYY
HT-110Y	Yellow	GaAsP	20	9 typ	2.1 typ	HT-110Y-YYYY
HT-110D	Orange	GaAsP	20	9 typ	2.1 typ	HT-110D-YYYY
HT-110SD	Red	GaAsP	20	9 typ	2.1 typ	HT-110SD-YYYY
HT-110UR	Bright Red	AlGaAs	20	20 typ	1.8 typ	HT-110UR-YYYY
HT-110UYG	Ultra Bright Yellow Green	AlInGaP	20	60 typ	2.0 typ	HT-110UYG-YYYY
HT-110UY	Ultra Bright Yellow	AlInGaP	20	120 typ	1.9 typ	HT-110UY-YYYY
HT-110UD	Ultra Bright Orange	AlInGaP	20	160 typ	1.9 typ	HT-110UD-YYYY
HT-110USD	Ultra Bright Red	AlInGaP	20	120 typ	1.9 typ	HT-110USD-YYYY
HT-110NB	Blue	InGaN	20	60 typ	3.3 typ	HT-110NB-YYYY
HT-110NG	True Green	InGaN	20	200 typ	3.3 typ	HT-110NG-YYYY
HT-110TW	White	InGaN	20	180 typ	3.3 typ	HT-110TW-YYYY

Official Product	Product: HT-110 Series		Data Sheet No.
Tentative Product	*****		HT-110 Series
Specifications are subject to change without notice. Data and drawings herein are copyrighted.		Mar. 03, 2005	Version of 1.0
			Page 4/25

	Specification	Material	Quantity
Resin	Water clear	Epoxy resin	
Carrier tape	Per EIA 481-1A specs	Conductive black tape	3000pcs per reel
Reel	Per EIA 481-1A specs	Conductive black	
Label	HT standard	Paper	
Packing bag	220x240mm	Aluminum laminated bag/ no-zipper	One reel per bag
Carton	HT standard	Paper	

Others:

Each immediate box consists of 5 reels. The 5 reels may not necessarily have the same lot number or the same bin combinations of I_v , λ_D and V_f . Each reel has a label identifying its specification; the immediate box consists of a product label as well.

ATTENTION: Electrostatic Discharge (ESD) protection



The symbol to the left denotes that ESD precaution is needed. ESD protection for GaP and AlGaAs based chips is necessary even though they are relatively safe in the presence of low static-electric discharge. Parts built with AlInGaP, GaN, or/and InGaN based chips are **STATIC SENSITIVE devices**. ESD precaution must be taken during design and assembly.

If manual work or processing is needed, please ensure the device is adequately protected from ESD during the process.

Compliance and Certification

ISO9002, QS9000 and ISO14001 Certified

RoHS Compliant



Official Product	Product: HT-110 Series	Data Sheet No.
Tentative Product	*****	HT-110 Series
Specifications are subject to change without notice. Data and drawings herein are copyrighted.	Mar. 03, 2005	Version of 1.0
		Page 5/25

Label Specifications

HARVATEK		Date: yyyy/mm/dd
CUSTOMER P/N: 		
HARVATEK P/N: 	QTY: PCS 	
LOT NO: 		QC
IV BIN: COLOR BIN: VF:		

 Harvatek P/N:

H T - 1 1 0 X X X - Y Y Y Y

Series Name	Emitting Color	Customer Code
HT-121 HT: Harvatek 110: Side-emitting series 3.2 (L) x 1.5 (W) x 1.0 (H) mm	XXX YG: Yellow Green Y: Yellow D: Orange SD: Red UR: Bright Red UYG: Ultra Bright Yellow Green UY: Ultra Bright Yellow UD: Ultra Bright Orange USD: Ultra Bright Red NB: Blue NG: True Green TW: White	YYYY Customer Product Code (TBD)

Official Product	Product: HT-110 Series	Data Sheet No.
Tentative Product	*****	HT-110 Series
Specifications are subject to change without notice. Data and drawings herein are copyrighted.	Mar. 03, 2005	Version of 1.0
		Page 6/25

Lot No.:

1 2 3 4 5 6 7 8 9 10
P 1 2 2 3 0 A - D T

Code 1	Code 2	Code 3	Code 4, 5	Code 6, 7	Code 9	Code 10
	Mfg. Year	Mfg. Month	Mfg. Date	Lots	Resin Color	Packaging
Internal Tracing Code	Z: 2000 1: 2001 2: 2002 3: 2003	1: Jan. 2: Feb. 9: Sep. A: Oct. B: Nov. C: Dec.	1~31/ (30)	01~99, A,B,C...	D: Diffused	T: Tape & Reel

 Luminous Intensity (Iv) Bin:

Bin	Luminous Intensity Range (mcd)		Bin	Luminous Intensity Range (mcd)	
	Minimum	Maximum		Minimum	Maximum
H1	2.8	3.6	H2	3.6	4.5
J1	4.5	5.7	J2	5.7	7.2
K1	7.2	9.0	K2	9.0	11.2
L1	11.2	14.2	L2	14.2	18.0
M1	18.0	22.5	M2	22.5	28.5
N1	28.5	36.0	N2	36.0	45.0
P1	45.0	57.0	P2	57.0	71.5
Q1	71.5	90.0	Q2	90.0	112.5
R1	112.5	142.0	R2	142.0	180.0
S1	180.0	227.0	S2	227.0	285.0
T1	285.0	360.0	T2	360.0	450.0
U1	450.0	570.0	U2	570.0	715.0

@20mA / Ta=25° C, Tolerance: ± 10%

Official Product	Product: HT-110 Series	Data Sheet No.
Tentative Product	*****	HT-110 Series
Specifications are subject to change without notice. Data and drawings herein are copyrighted.	Mar. 03, 2005	Version of 1.0
		Page 7/25

Wavelength (λ_D) Bin:

Bin	Wavelength Range (nm)									
	Bright Red (UR)		Red (SD)		Orange (D)		Yellow (Y)		Yellow Green (YG)	
	Min	Max	Min	Max	Min	Max	Min	Max	Min	Max
-	620.0	650.0	615.0	635.0						
A					597.0	600.0	582.0	584.5	561.5	564.5
B					600.0	603.0	584.6	587.0	564.5	567.5
C					603.0	606.0	587.0	589.5	567.5	570.5
D					606.0	609.0	589.5	592.0	570.5	573.5
E					609.0	612.0			573.5	576.5
F					612.0	615.0				
H							592.0	594.5		
J							594.5	597.0		

@20mA / Ta=25° C, Tolerance: \pm 0.5nm

Bin	Wavelength Range (nm)							
	Red (USD)		Orange (UD)		Yellow (UY)		Yellow Green (UYG)	
	Min	Max	Min	Max	Min	Max	Min	Max
-	615.0	630.0						
A			597.0	600.0	582.0	584.5	561.5	564.5
B			600.0	603.0	584.6	587.0	564.5	567.5
C			603.0	606.0	587.0	589.5	567.5	570.5
D			606.0	609.0	589.5	592.0	570.5	573.5
E			609.0	612.0			573.5	576.5
F			612.0	615.0				
H					592.0	594.5		
J					594.5	597.0		

@20mA / Ta=25° C, Tolerance: \pm 0.5nm

Official Product	Product: HT-110 Series	Data Sheet No.
Tentative Product	*****	HT-110 Series
Specifications are subject to change without notice. Data and drawings herein are copyrighted.	Mar. 03, 2005	Version of 1.0
		Page 8/25

Bin	Wavelength Range (nm)			
	True Green (NG)		Blue (NB)	
	Min	Max	Min	Max
-				
A	515.0	520.0	460.0	464.0
B	520.0	525.0	464.0	468.0
C	525.0	530.0	468.0	472.0
D	530.0	535.0	472.0	476.0
E	535.0	540.0	476.0	480.0
F			480.0	485.0
H				
J				

@20mA / Ta=25° C, Tolerance: ± 0.5nm

Forward Voltage (V_F) Bin:

Color	Bin Code	Spec. Range
Blue (NB) Green (NG) White (TW)	G8	2.7-2.9 V
	H7	2.9-3.1 V
	H8	3.1-3.3 V
	J7	3.3-3.5 V
	J8	3.5-3.7 V
	K7	3.7-3.9 V
Ultra Bright (UYG, UY, UD, USD)	-	2.4 V max
Standard Bright (YG, Y, D, SD)	-	2.6 V max
Bright Red (UR)	-	2.2 V max

@20mA / Ta=25°C, Tolerance: ± 0.05 V

Official Product	Product: HT-110 Series		Data Sheet No.
Tentative Product	*****		HT-110 Series
Specifications are subject to change without notice. Data and drawings herein are copyrighted.	Mar. 03, 2005	Version of 1.0	Page 9/25

Chromaticity Bin (for TW only):

Rank C1				
x	0.2500	0.2700	0.2700	0.2500
y	0.2500	0.2775	0.2325	0.2050

Rank C2				
x	0.2700	0.2900	0.2900	0.2700
y	0.2775	0.3050	0.2600	0.2325

Rank D1				
x	0.2900	0.3100	0.3100	0.2900
y	0.3050	0.3325	0.2875	0.2600

Rank D2				
x	0.3100	0.3300	0.3300	0.3100
y	0.3325	0.3600	0.3150	0.2875

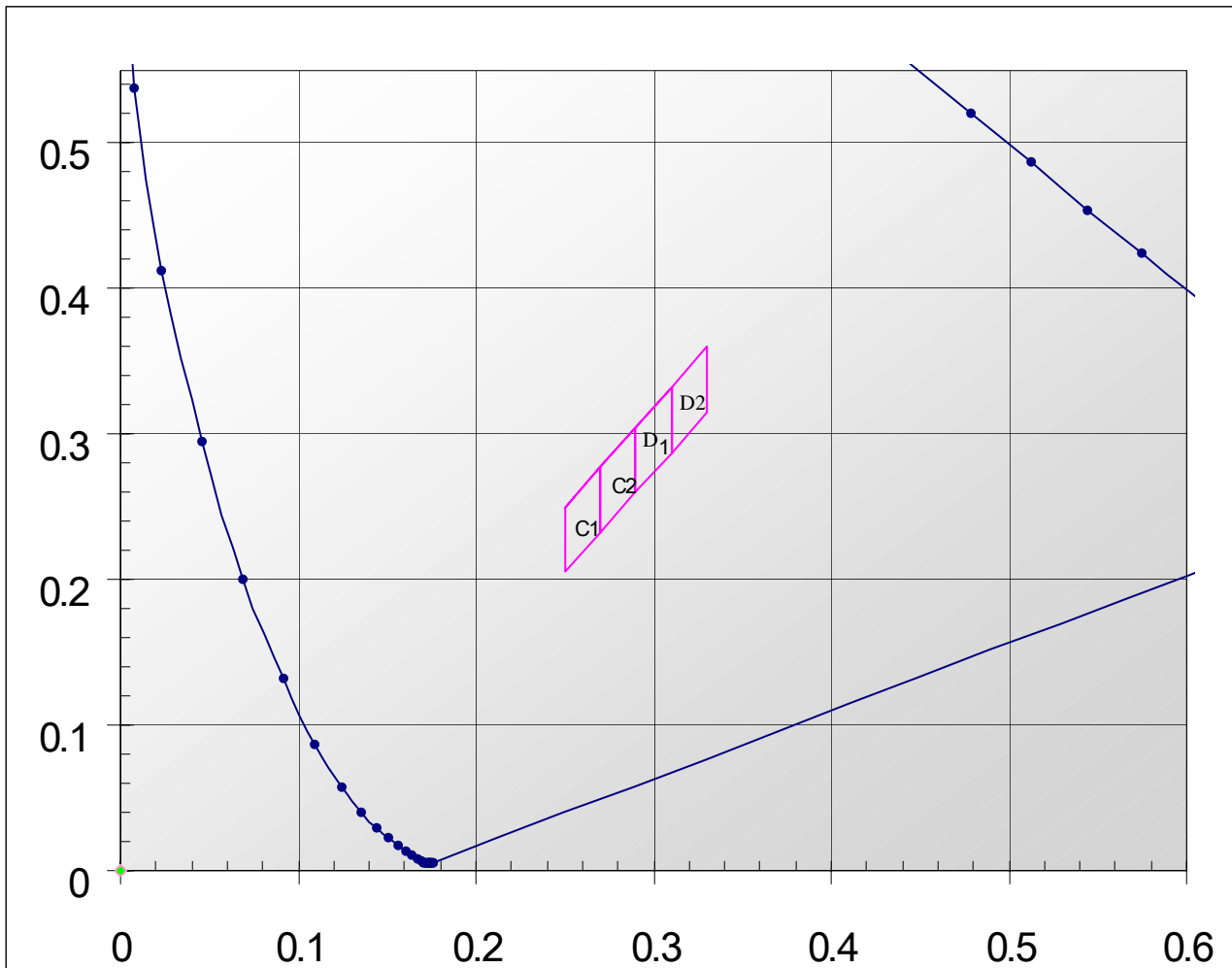

@20mA / Ta=25°C, Tolerance: ± 0.01

Official Product	Product: HT-110 Series	Data Sheet No.	
Tentative Product	*****	HT-110 Series	
Specifications are subject to change without notice. Data and drawings herein are copyrighted.	Mar. 03, 2005	Version of 1.0	Page 10/25

Product Characteristics

Absolute Maximum Ratings

Product	Emission Color	P _d (mW)	I _F (mA)	I _{FP} * (mA)	V _R (V)	T _{OP} (°C)	T _{ST} (°C)
HT-110YG	Yellow Green	65	25	100	5	-30°C~+80°C	-40°C~+85°C
HT-110Y	Yellow						
HT-110D	Orange						
HT-110SD	Red						
HT-110UR	Bright Red	66	30	100			
HT-110UYG	Ultra Bright Yellow Green	72	30	100			
HT-110UY	Ultra Bright Yellow						
HT-110UD	Ultra Bright Orange						
HT-110USD	Ultra Bright Red						
HT-110NB	Blue	78	20	80			
HT-110NG	True Green						
HT-110TW	White						

* Condition for I_{FP} is pulse of 1/10 duty and 0.1msec width

Official Product	Product: HT-110 Series		Data Sheet No.
Tentative Product	*****		HT-110 Series
Specifications are subject to change without notice. Data and drawings herein are copyrighted.		Mar. 03, 2005	Version of 1.0
			Page 11/25

Electro-Optical Characteristics

(T_a 25 °C)

Product	Emission Color	I _F (mA)	V _F (V)		λ(nm)			I _V (mcd)	
			typ	max	λ _D	λ _P	Δλ	min	typ
HT-110YG	Yellow Green	20	2.2	2.6	573	568	30	9	16
HT-110Y	Yellow	20	2.1	2.6	590	589	35	5.6	9
HT-110D	Orange	20	2.1	2.6	608	610	35	5.6	9
HT-110SD	Red	20	2.1	2.6	629	642	35	3.6	9
HT-110UR	Bright Red	20	1.8	2.2	643	660	20	9	20
HT-110UYG	Ultra Bright Yellow Green	20	2.0	2.4	573	574	20	36	60
HT-110UY	Ultra Bright Yellow	20	1.9	2.4	589	593	15	36	120
HT-110UD	Ultra Bright Orange	20	1.9	2.4	605	609	17	56	160
HT-110USD	Ultra Bright Red	20	1.9	2.4	622	636	17	56	120
HT-110NB	Blue	20	3.3	3.9	470	468	40	36	60
HT-110NG	True Green	20	3.3	3.9	527	520	40	140	200
HT-110TW	White	20	3.3	3.9	X=0.29 Y=0.31	-	-	90	180

* Per NIST standards

Official Product	Product: HT-110 Series		Data Sheet No.
Tentative Product	*****		HT-110 Series
Specifications are subject to change without notice. Data and drawings herein are copyrighted.		Mar. 03, 2005	Version of 1.0
			Page 12/25

Package Outline Dimension
Recommended Soldering Pattern for Reflow Soldering

Unit: mm Tolerance: +/-0.1

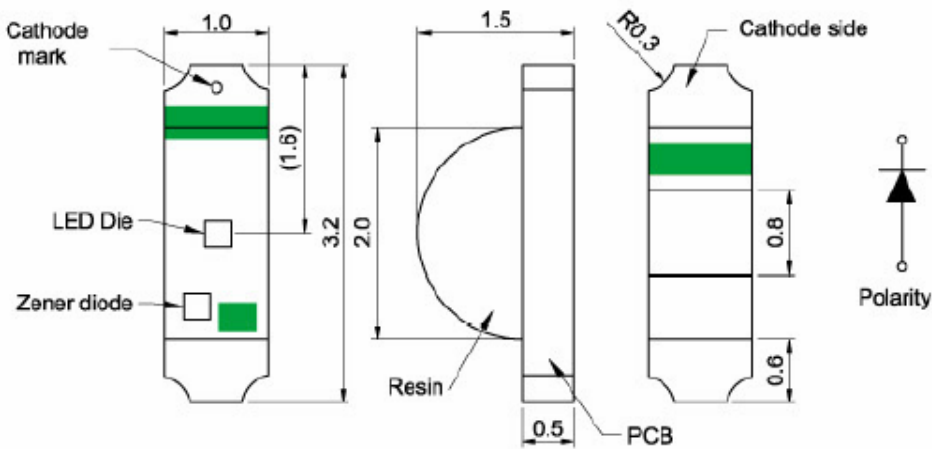
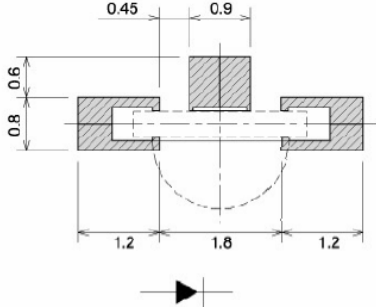
Outline Dimension	Solder Pattern
 <p>1. Soldering terminal may shift in x, y direction. 2. Polarity referring onto the cathode line is reversed on the UR.</p>	
<p>Soldering terminals may shift in the x, y direction.</p>	<p>Unit: mm</p>

Official Product	Product: HT-110 Series		Data Sheet No.
Tentative Product	*****		HT-110 Series
Specifications are subject to change without notice. Data and drawings herein are copyrighted.	Mar. 03, 2005	Version of 1.0	Page 13/25

Characteristic Curves for YG, Y, D, SD and UR

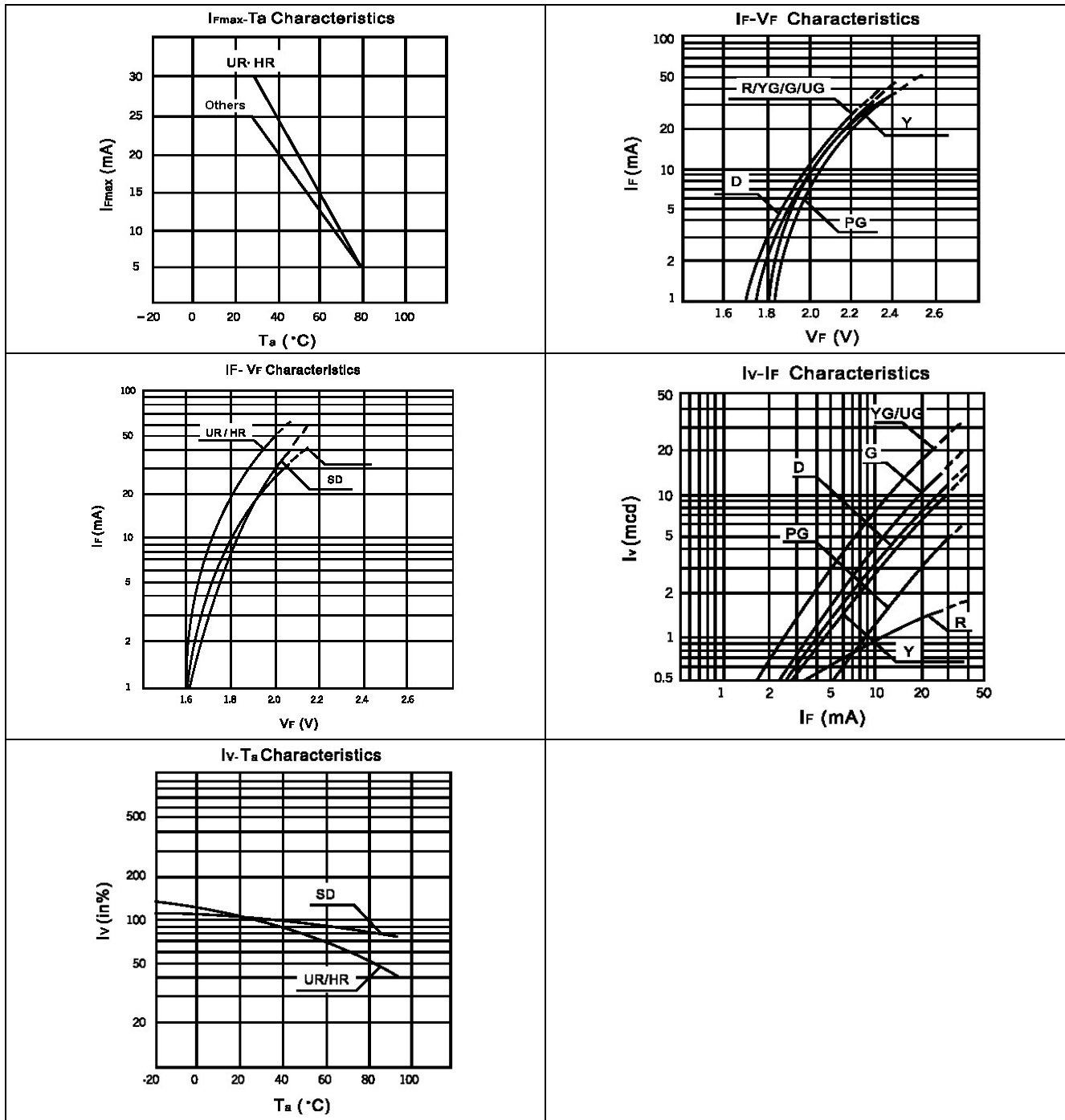

Official Product	Product: HT-110 Series	Data Sheet No.
Tentative Product	*****	HT-110 Series
Specifications are subject to change without notice. Data and drawings herein are copyrighted.	Mar. 03, 2005	Version of 1.0
		Page 14/25

Characteristic Curves for UYG, UY, UD and USD

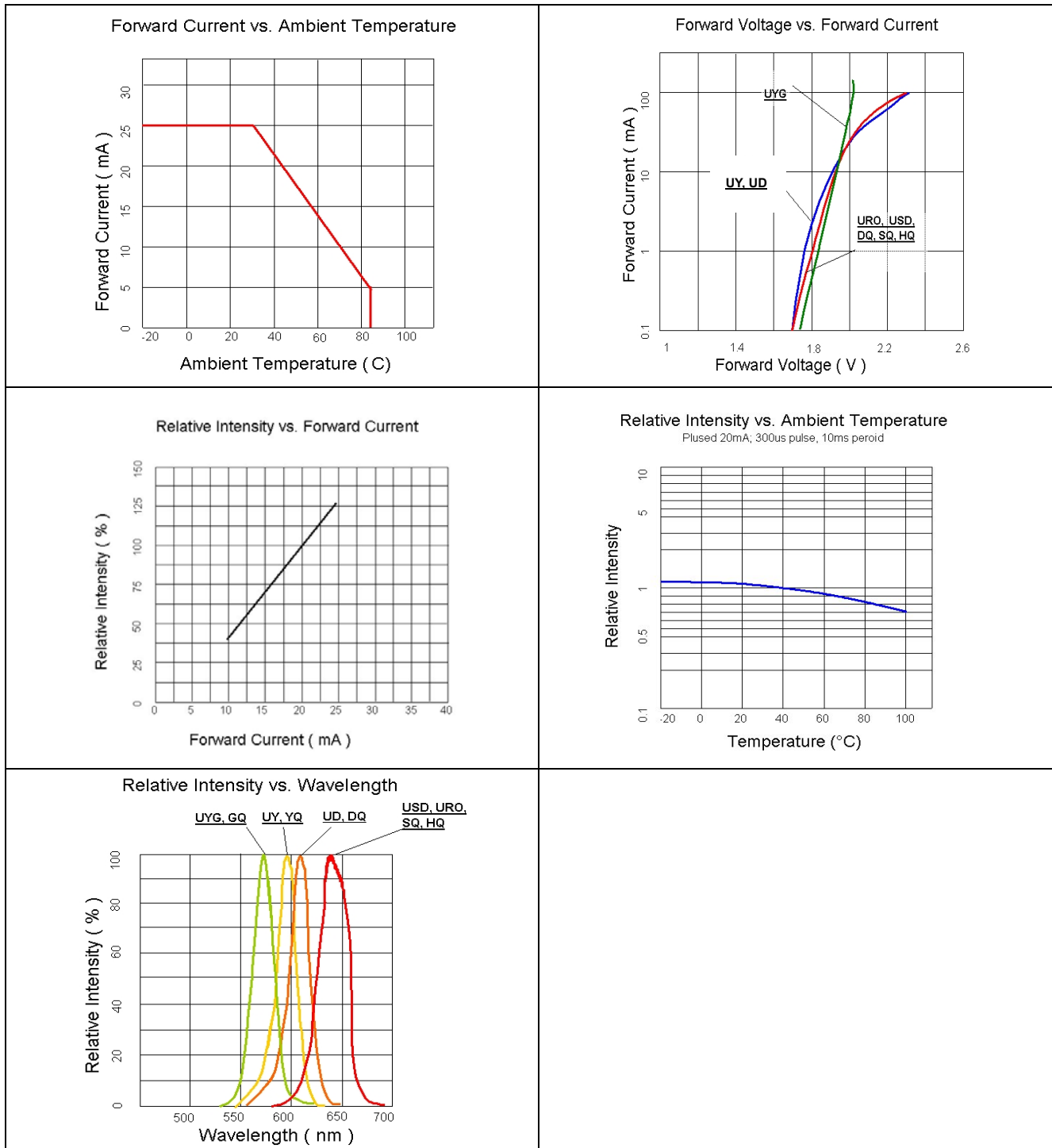

Official Product	Product: HT-110 Series	Data Sheet No.
Tentative Product	*****	HT-110 Series
Specifications are subject to change without notice. Data and drawings herein are copyrighted.	Mar. 03, 2005	Version of 1.0
		Page 15/25

Characteristic Curves for NB, NG and TW

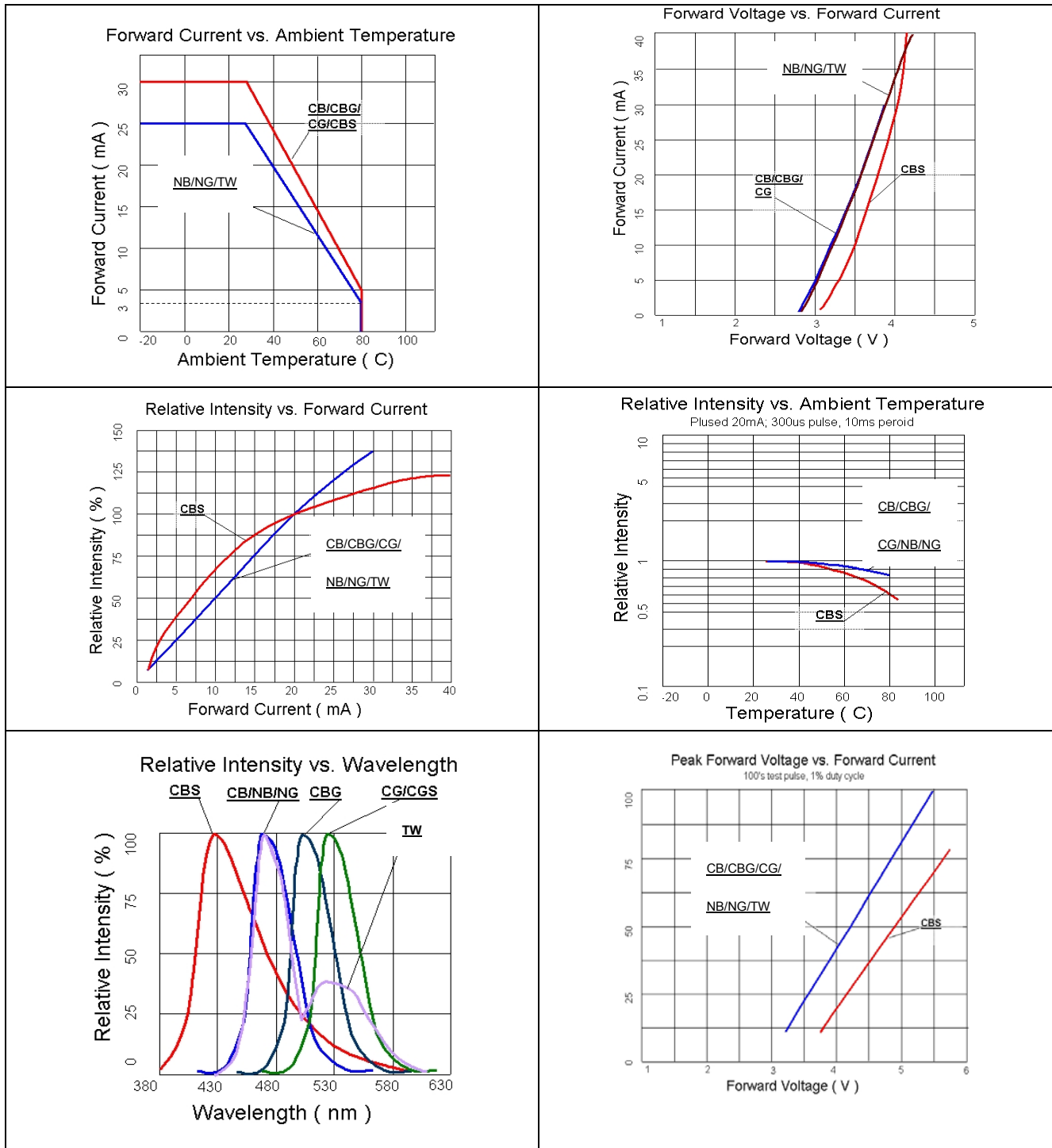

Official Product	Product: HT-110 Series	Data Sheet No.
Tentative Product	*****	HT-110 Series
Specifications are subject to change without notice. Data and drawings herein are copyrighted.	Mar. 03, 2005	Version of 1.0
		Page 16/25

Characteristic Curves for All Colors (Radiation Pattern)

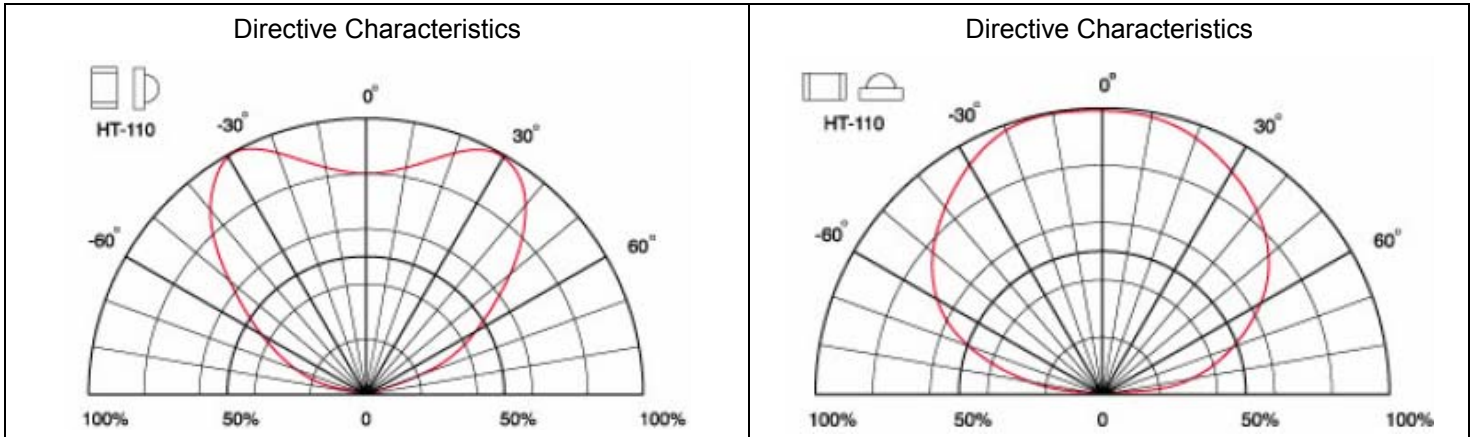

Official Product	Product: HT-110 Series	Data Sheet No.
Tentative Product	*****	HT-110 Series
Specifications are subject to change without notice. Data and drawings herein are copyrighted.	Mar. 03, 2005	Version of 1.0
		Page 17/25

Packaging

Tape Dimension

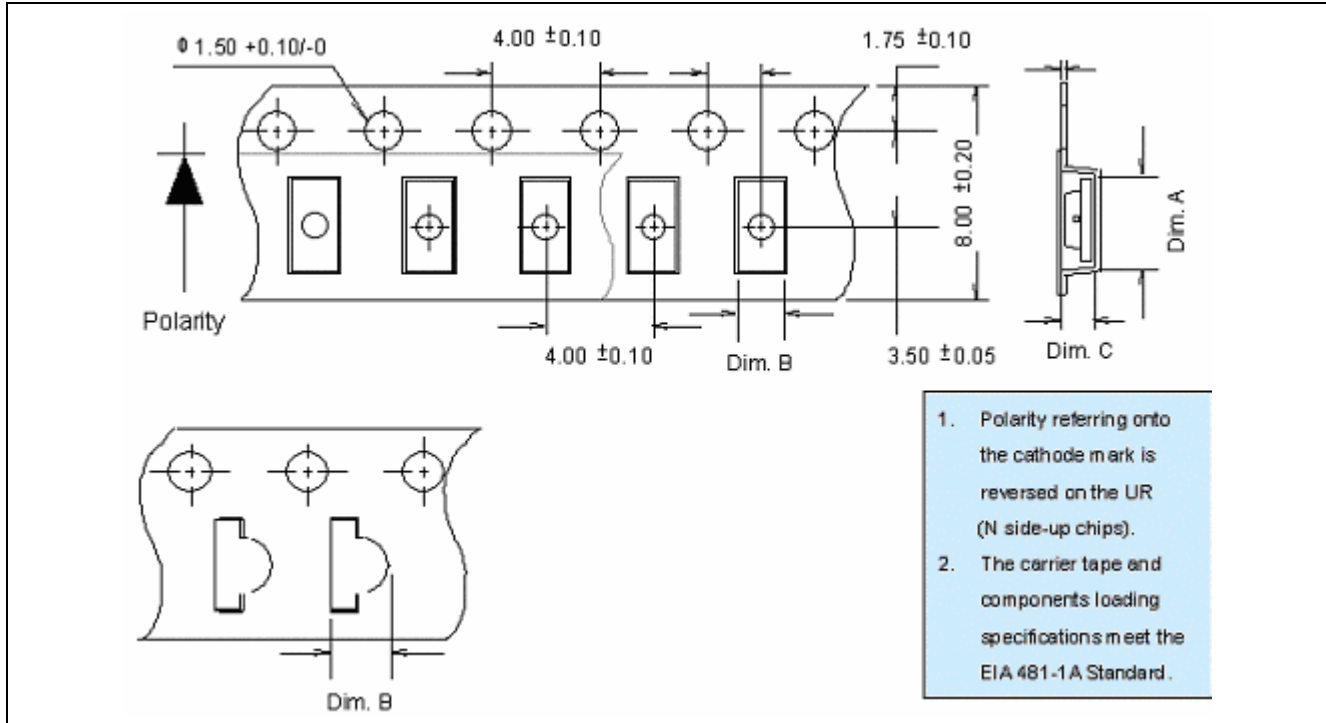

Part No.	Dim. A	Dim. B	Dim. C	Q'ty/Reel
HT-110	3.40 ± 0.10	1.70 ± 0.10	1.20 ± 0.10	3K

Unit: mm

Official Product	Product: HT-110 Series	Data Sheet No.
Tentative Product	*****	HT-110 Series
Specifications are subject to change without notice. Data and drawings herein are copyrighted.	Mar. 03, 2005	Version of 1.0
		Page 18/25

Reel Dimension

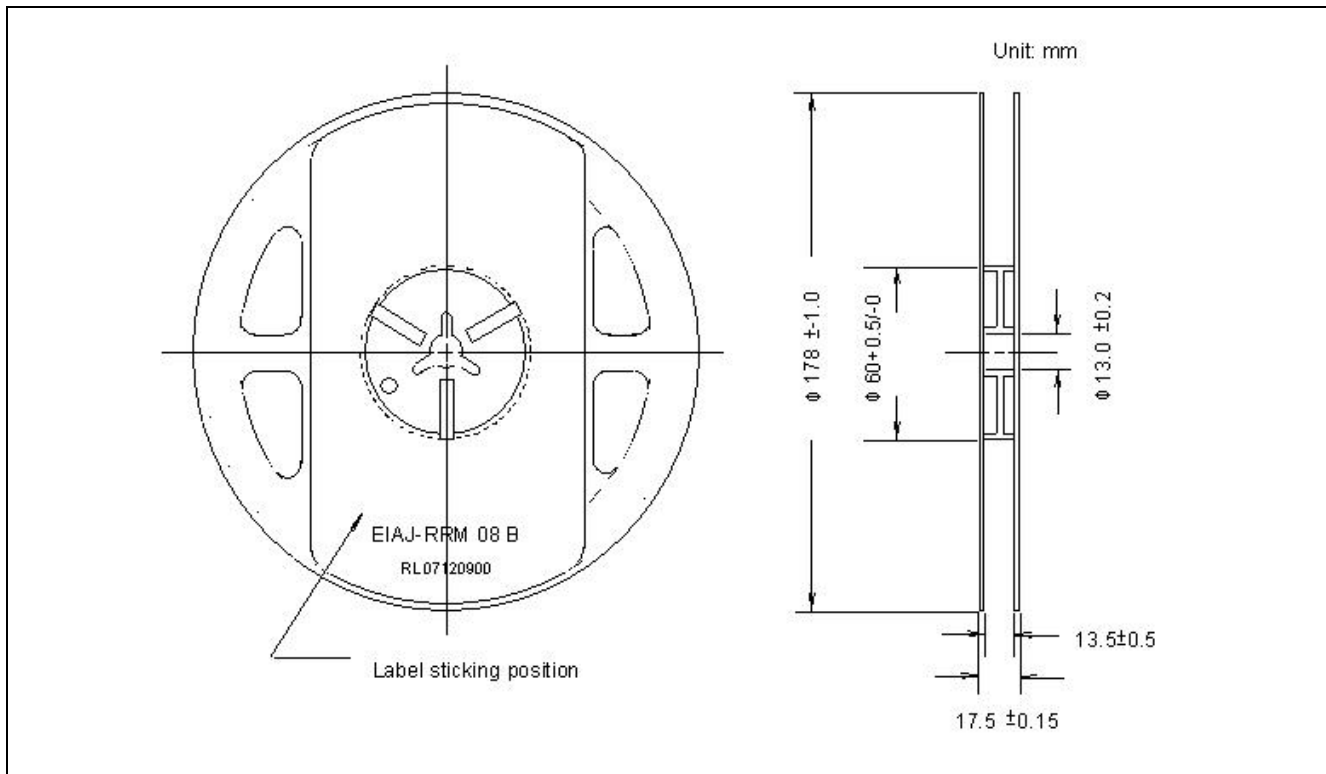

Official Product	Product: HT-110 Series	Data Sheet No.
Tentative Product	*****	HT-110 Series
Specifications are subject to change without notice. Data and drawings herein are copyrighted.	Mar. 03, 2005	Version of 1.0
		Page 19/25

Packing

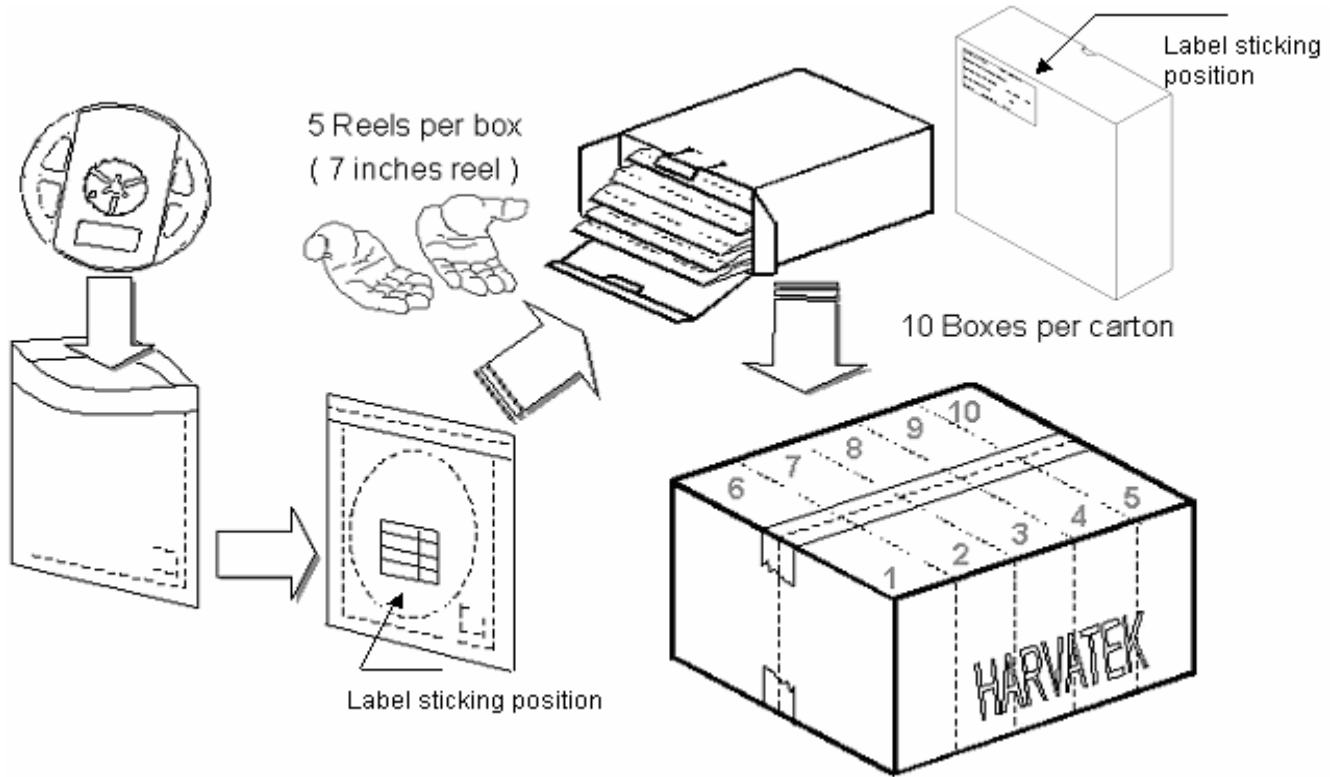

5 boxes per carton is available depending on shipment quantity.

	Specification	Material	Quantity
Carrier tape	Per EIA 481-1A specs	Conductive black tape	4000pcs per reel
Reel	Per EIA 481-1A specs	Conductive black	
Label	HT standard	Paper	
Packing bag	220x240mm	Aluminum laminated bag/ no-zipper	One reel per bag
Carton	HT standard	Paper	Non-specified

Others:

Each immediate box consists of 5 reels. The 5 reels may not necessarily have the same lot number or the same bin combinations of Iv, λ_D and Vf. Each reel has a label identifying its specification; the immediate box consists of a product label as well.

Official Product	Product: HT-110 Series	Data Sheet No.
Tentative Product	*****	HT-110 Series
Specifications are subject to change without notice. Data and drawings herein are copyrighted.	Mar. 03, 2005	Version of 1.0
		Page 20/25

Dry Pack

All SMD optical devices are **MOISTURE SENSITIVE**. Avoid exposure to moisture at all times during transportation or storage. Every reel is packaged in a moisture protected anti-static bag. Each bag is properly sealed prior to shipment.

Upon request, a humidity indicator will be included in the moisture protected anti-static bag prior to shipment.

The packaging sequence is as follows:

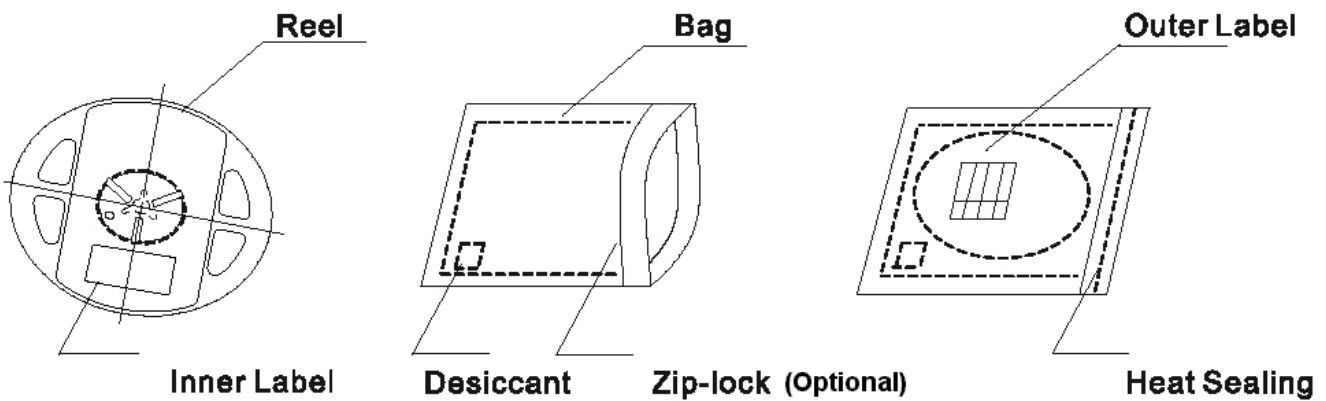

Official Product	Product: HT-110 Series			Data Sheet No.
Tentative Product	*****			HT-110 Series
Specifications are subject to change without notice. Data and drawings herein are copyrighted.	Mar. 03, 2005	Version of 1.0	Page 21/25	

Reflow Soldering

- Recommended tin glue specifications: melting temperature in the range of 178~192 °C
- The recommended reflow soldering profile is as follows (temperatures indicated are as measured on the surface of the LED resin):

Lead Solder Profile

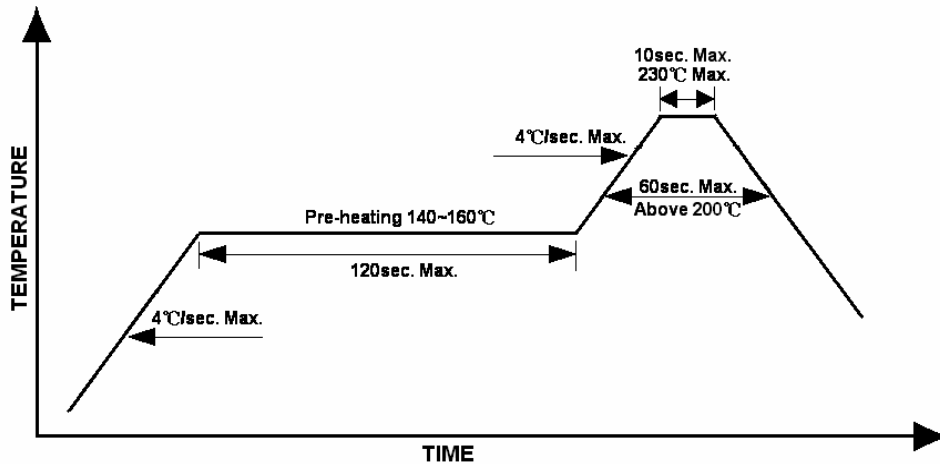

Lead-free Solder Profile

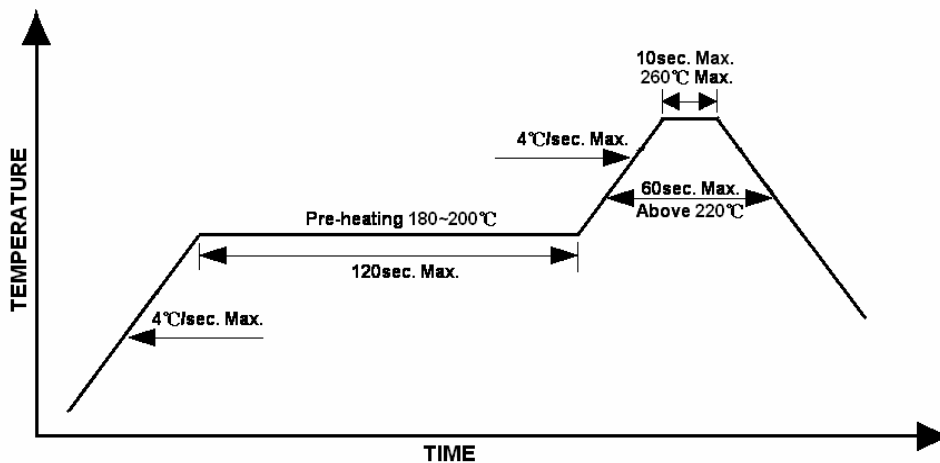

Official Product	Product: HT-110 Series	Data Sheet No.	
Tentative Product	*****	HT-110 Series	
Specifications are subject to change without notice. Data and drawings herein are copyrighted.	Mar. 03, 2005	Version of 1.0	Page 22/25

Wave Soldering

- Maximum soldering temperature is 260°C for 5 seconds.

Precautions

1. Avoid exposure to moisture at all times during transportation or storage.
2. Anti-Static precaution must be taken when handling GaN, InGaN, and AlInGaP products.
3. It is suggested to connect the unit with a current limiting resistor of the proper size. Avoid applying a reverse voltage beyond the specified limit.
4. Avoid operation beyond the limits as specified by the absolute maximum ratings.
5. Avoid direct contact with the surface through which the LED emits light.
6. If possible, assemble the unit in a clean room or dust-free environment.

Reworking

- Rework should be completed within 5 seconds under 260 °C.
- The iron tip must not come in contact with the copper foil.
- Twin-head type is preferred.

Cleaning

Following are cleaning procedures after soldering:

- An alcohol-based solvent such as isopropyl alcohol (IPA) is recommended.
- Temperature x Time should be 50°C x 30sec. or <30°C x 3min
- Ultra sonic cleaning: < 15W/ bath; bath volume ≤ 1liter
- Curing: 100 °C max, <3min

Cautions of Pick and Place

- Avoid stress on the resin at elevated temperature.
- Avoid rubbing or scraping the resin by any object.
- Electro-static may cause damage to the component. Please ensure that the equipment is properly grounded. Use of an ionizer fan is recommended.

Official Product	Product: HT-110 Series			Data Sheet No.
Tentative Product	*****			HT-110 Series
Specifications are subject to change without notice. Data and drawings herein are copyrighted.	Mar. 03, 2005	Version of 1.0	Page 23/25	

Reliability

Item	Frequency/ lots/ samples/ failures	Standards Reference	Conditions
Precondition	For all reliability monitoring tests according to JEDEC Level 2	J-STD-020	1.) Baking at 85°C for 24hrs 2.) Moisture storage at 85°C/ 60% R.H. for 168hrs
Solderability	1Q/ 1/ 22/ 0	JESD22-B102-B And CNS-5068	Accelerated aging 155°C/ 24hrs Tinning speed: 2.5+0.5cm/s Tinning: A: 215°C/ 3+1s or B: 260°C/ 10+1s
Resistance to soldering heat		CNS-5067	Dipping soldering terminal only Soldering bath temperature A: 260+/-5°C; 10+/-1s B: 350+/-10°C; 3+/-0.5s
Operating life test	1Q/ 1/ 40/ 0	CNS-11829	1.) Precondition: 85°C baking for 24hrs 85°C/ 60%R.H. for 168hrs 2.) Tamb25°C; IF=20mA; duration 1000hrs
High humidity, high temperature bias	1Q/ 1/ 45/ 0	JESD-A101-B	Tamb: 85°C Humidity: 85% R.H., IF=5mA Duration: 1000hrs
High temperature bias	1Q/ 1/ 20	HT specs.	Tamb: 55°C IF=20mA Duration: 1000hrs
Pulse life test	1Q/ 1/ 40/ 0		Tamb25°C, If=20mA,, Ip=100mA, Duty cycle=0.125 (tp=125µs,T=1sec) Duration 500hrs)
Temperature cycle	1Q/ 1/ 76/ 0	JESD-A104-A IEC 68-2-14, Nb	A cycle: -40 degree C 15min; +85 degree C 15min Thermal steady within 5 min.. 300 cycles 2 chamber/ Air-to-air type
High humidity storage test	1Q/ 1/ 40/ 0	CNS-6117	60+3°C 90+5/-10% R.H. for 500hrs
High temperature storage test	1Q/ 1/ 40/ 0	CNS-554	100+10°C for 500hrs
Low temperature storage test	1Q/ 1/ 40/ 0	CNS-6118	-40+5°C for 500hrs

Official Product	Product: HT-110 Series		Data Sheet No.
Tentative Product	*****		HT-110 Series
Specifications are subject to change without notice. Data and drawings herein are copyrighted.	Mar. 03, 2005	Version of 1.0	Page 24/25

Revision History

Changes since last revision	Page	Version No.	Revision Date
New format		1.0	03-03-2006

Official Product	Product: HT-110 Series		Data Sheet No.
Tentative Product	*****		HT-110 Series
Specifications are subject to change without notice. Data and drawings herein are copyrighted.	Mar. 03, 2005	Version of 1.0	Page 25/25



Компания «ЭлектроПласт» предлагает заключение долгосрочных отношений при поставках импортных электронных компонентов на взаимовыгодных условиях!

Наши преимущества:

- Оперативные поставки широкого спектра электронных компонентов отечественного и импортного производства напрямую от производителей и с крупнейших мировых складов;
- Поставка более 17-ти миллионов наименований электронных компонентов;
- Поставка сложных, дефицитных, либо снятых с производства позиций;
- Оперативные сроки поставки под заказ (от 5 рабочих дней);
- Экспресс доставка в любую точку России;
- Техническая поддержка проекта, помощь в подборе аналогов, поставка прототипов;
- Система менеджмента качества сертифицирована по Международному стандарту ISO 9001;
- Лицензия ФСБ на осуществление работ с использованием сведений, составляющих государственную тайну;
- Поставка специализированных компонентов (Xilinx, Altera, Analog Devices, Intersil, Interpoint, Microsemi, Aeroflex, Peregrine, Syfer, Eurofarad, Texas Instrument, Miteq, Cobham, E2V, MA-COM, Hittite, Mini-Circuits, General Dynamics и др.);

Помимо этого, одним из направлений компании «ЭлектроПласт» является направление «Источники питания». Мы предлагаем Вам помощь Конструкторского отдела:

- Подбор оптимального решения, техническое обоснование при выборе компонента;
- Подбор аналогов;
- Консультации по применению компонента;
- Поставка образцов и прототипов;
- Техническая поддержка проекта;
- Защита от снятия компонента с производства.



Как с нами связаться

Телефон: 8 (812) 309 58 32 (многоканальный)

Факс: 8 (812) 320-02-42

Электронная почта: org@eplast1.ru

Адрес: 198099, г. Санкт-Петербург, ул. Калинина, дом 2, корпус 4, литера А.