

DC-DC Converter Specification

MYFSP3R303FMS

1. Application

This specification applies to DC-DC Converter for telecommunication / data-communication equipment, MYFSP3R303FMS.

For any other application, please contact us before using this product.

2. Customer Reference

Customer Spec. Number

Customer Part Number

3. Murata Part Number

MYFSP3R303FMS

4. Appearance, Dimensions

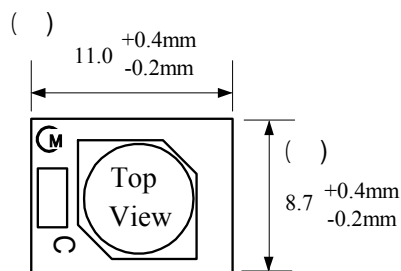

[Unit : mm] Tolerance : 0.2mm

Tolerance is not accumulated.

Coplanarity 0.15mm max.

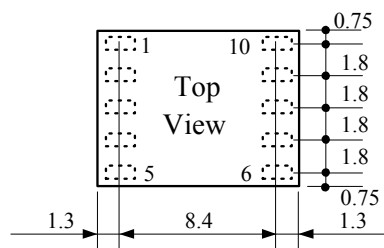
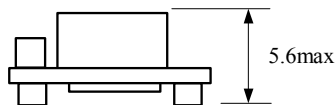

Marking

(1) Pin No.1 Marking / MFG ID 

(2) Parts No. C

(3) Lot No.

Production Year

Production Month (1,2,3,...9,O,N,D)

⚠ Note:

- This datasheet is downloaded from the website of Murata Manufacturing co., ltd. Therefore, it's specifications are subject to change or our products in it may be discontinued without advance notice. Please check with our sales representatives or product engineers before ordering.
- This datasheet has only typical specifications because there is no space for detailed specifications. Therefore, please approve our product specifications or transact the approval sheet for product specifications before ordering.

5. Pin Number and Function

Pin No.	Symbol	Function
1	ISHARE	Current Share (for parallel operation)
2	TRIM	Output voltage adjustment
3	Vout	Output
4,6	GND	GND
5	+SENSE	Output voltage sense
7	ON/OFF	Remote ON/OFF
8	Vin	Input
9	Pgood	Power good output
10	PO	Synchronous Turn-off (for parallel operation)

6. Block Diagram

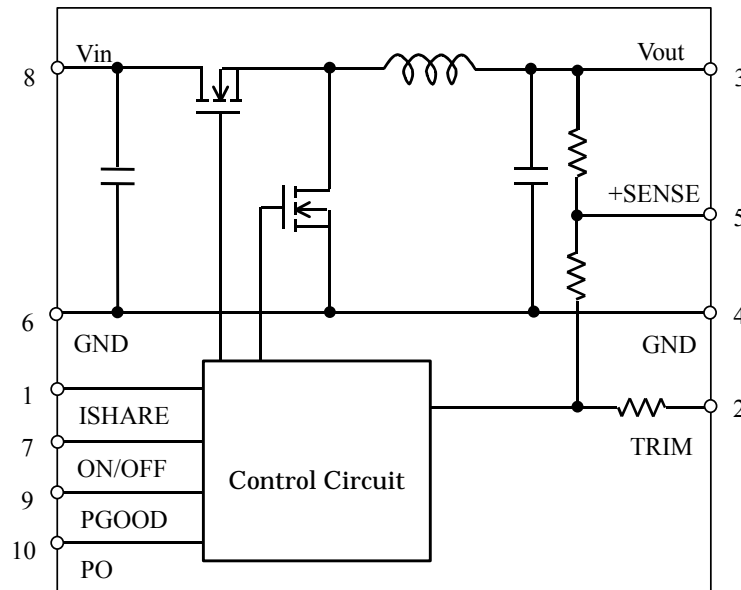

7. Environmental Conditions

7.1 Operating Temperature Range	-40°C ~ +85°C
7.2 Storage Temperature Range	-40°C ~ +85°C
7.3 Operating Humidity Range	20% ~ 85% (No water condenses in any cases.)
7.4 Storage Humidity Range	10% ~ 90% (No water condenses in any cases.)

8. Absolute Maximum Rating

Item	Unit	Absolute Rating	Remarks
Minimum Input Voltage	V	0	
Maximum Input Voltage	V	5.5	
ON/OFF Pin Maximum input Voltage	V	Vin	
PGOOD Pin Maximum input Voltage	V	Vin	

No voltage, no matter how instantaneous, shall be applied beyond the absolute maximum voltage rating to this product. If you apply any voltage over this limit the product characteristics will deteriorate or the product itself will be destroyed. Even though it may continue operating for a while after the over-voltage event, its life will likely be shortened significantly. Reliability and life of the module may degrade similarly if the maximum operating voltage rating is continuously exceeded. This product is designed to operate within the maximum operating voltage rating specification.

⚠ Note:

1. This datasheet is downloaded from the website of Murata Manufacturing co., ltd. Therefore, it's specifications are subject to change or our products in it may be discontinued without advance notice. Please check with our sales representatives or product engineers before ordering.
2. This datasheet has only typical specifications because there is no space for detailed specifications. Therefore, please approve our product specifications or transact the approval sheet for product specifications before ordering.

9. Characteristics

9.1. Electrical Characteristics

9.1.1. Input Characteristics (Ta= 25°C)

Item	Symbol	Condition	Value			Unit
			Min.	Typ.	Max.	
Input Voltage Range	Vin		3.0	-	5.5	V
Rising UVLO Threshold	UVLOr	Vin increase	2.2	2.55	2.9	V
Falling UVLO Threshold	UVLOf	Vin decreasing	2.15	2.5	2.85	V

9.1.2. Interface Characteristics (Ta= 25°C)

Item	Symbol	Condition	Value			Unit
			Min.	Typ.	Max.	
ON/OFF pin High Voltage	VIH	ON	2.0	-	Vin	V
ON/OFF pin Low Voltage	VIL	OFF	0	-	0.8	V
PGOOD pin Internal ON Resistance	Rpg			140	280	

9.1.3. General Characteristics (Ta= 25°C)

Item	Symbol	Condition	Value			Unit
			Min.	Typ.	Max.	
Output Voltage Range	Vout	Vin=3.0V-5.5V Note : VinMin.=Vout+1.2V at Vout 1.6V	0.7	-	3.3	V
Output Current	Iout	See the thermal derating curve in clause 9.1.4	0	-	3	A
Output Voltage Tolerance	Vo tol	Over Vin, Temperature range Rset=0.5% tolerance Io=0.1A ~ 3A	-3.0	-	+3.0	%Vo
Ripple Voltage	Vrpl	Vin=5V, Vout=3.3V, Iout=3A BW =20MHz,	-	20	50	mV(pp)
Efficiency	EFF	Vin =5V, Vout=3.3V, Iout=3A	-	89	-	%
Short Circuit Protection	SCP	Hiccup-mode operation after a mask time: Thd. After correction of the abnormal condition, the DC-DC Converter will restart.	-	5	-	A
Hiccup Delay Time	Thd		0.5	1	2	msec
Operating Frequency	Frq			1000		kHz
Power Good Detection Range	ΔVpg		-	± 10	-	%Vo
External Output Capacitor	Cout	When input voltage is ideal voltage source	0		300	μF
Rising Overshoot	Vover		-	0	+5	%
Output Rise Time	Tr	Output voltage 0-90% (remote on)	0.5	1	5	msec

⚠ Caution

The above electrical characteristics are guaranteed with the condition that the impedance of the input voltage source is sufficiently low as shown in section 10. Connecting an input inductance or using an input power supply with output inductance may cause an unstable operation of this device. Please check the proper operation of this device with the peripheral circuits on your system.

⚠ Note:

1. This datasheet is downloaded from the website of Murata Manufacturing co., ltd. Therefore, it's specifications are subject to change or our products in it may be discontinued without advance notice. Please check with our sales representatives or product engineers before ordering.
2. This datasheet has only typical specifications because there is no space for detailed specifications. Therefore, please approve our product specifications or transact the approval sheet for product specifications before ordering.

9.1.4. Thermal Derating

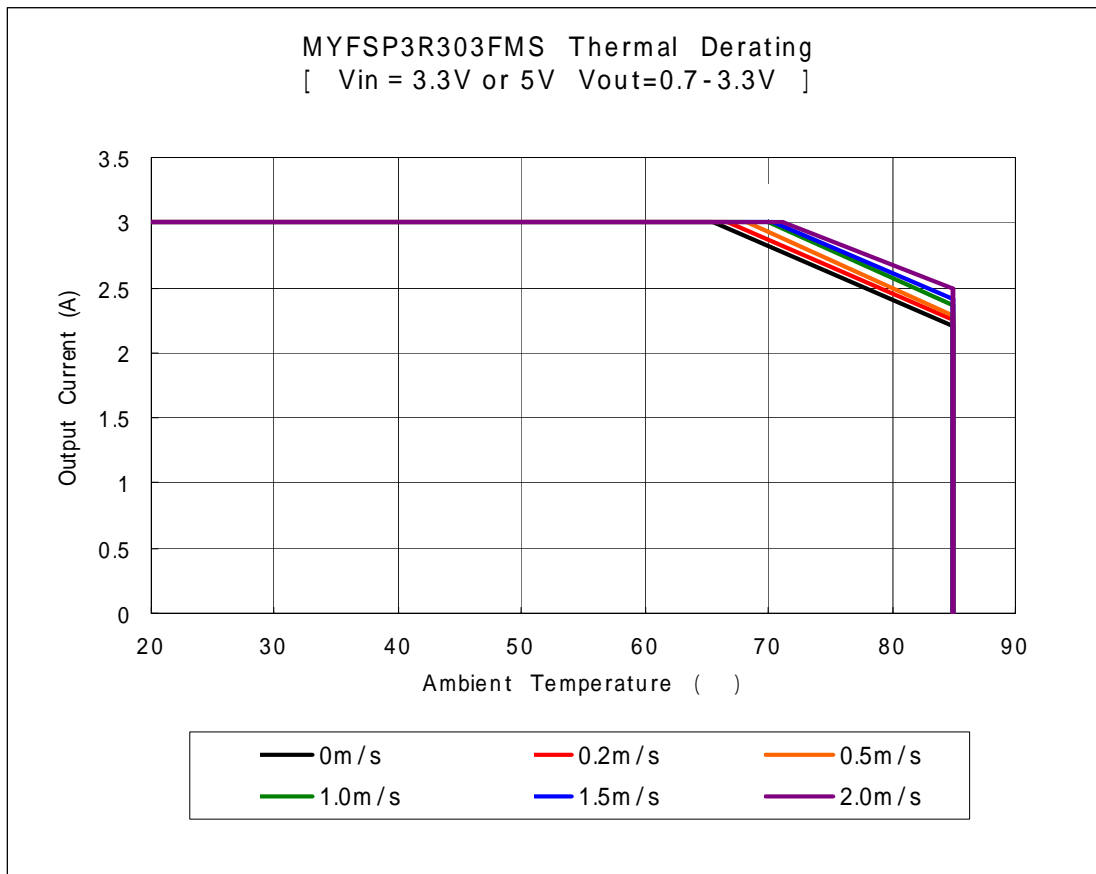

The above derating limits apply to this product soldered directly to 101.6*180mm*1.6mm PCB (double-sided, with 70um copper). Any adjacent parts of high temperature may cause overheating. For reliable operation, please ensure that the IC temperature of this product is maintained below 120°C and the inductor temperature is below 119°C.

⚠ Note:

1. This datasheet is downloaded from the website of Murata Manufacturing co., ltd. Therefore, it's specifications are subject to change or our products in it may be discontinued without advance notice. Please check with our sales representatives or product engineers before ordering.
2. This datasheet has only typical specifications because there is no space for detailed specifications. Therefore, please approve our product specifications or transact the approval sheet for product specifications before ordering.

9.2. Operation Information

9.2.1. Output Voltage Adjustment

The output voltage can be adjusted from 0.7V to 3.3V by connecting resistors between TRIM-pin(2Pin) to GND-pin(Pin 4 is recommended for accurate Vout setting).

The following equation gives the required external-resistor values to adjust the output voltage to the required Vout.

It is highly recommended that evaluation of the characteristics of this DC-DC converter's operation under your board conditions be thoroughly conducted.

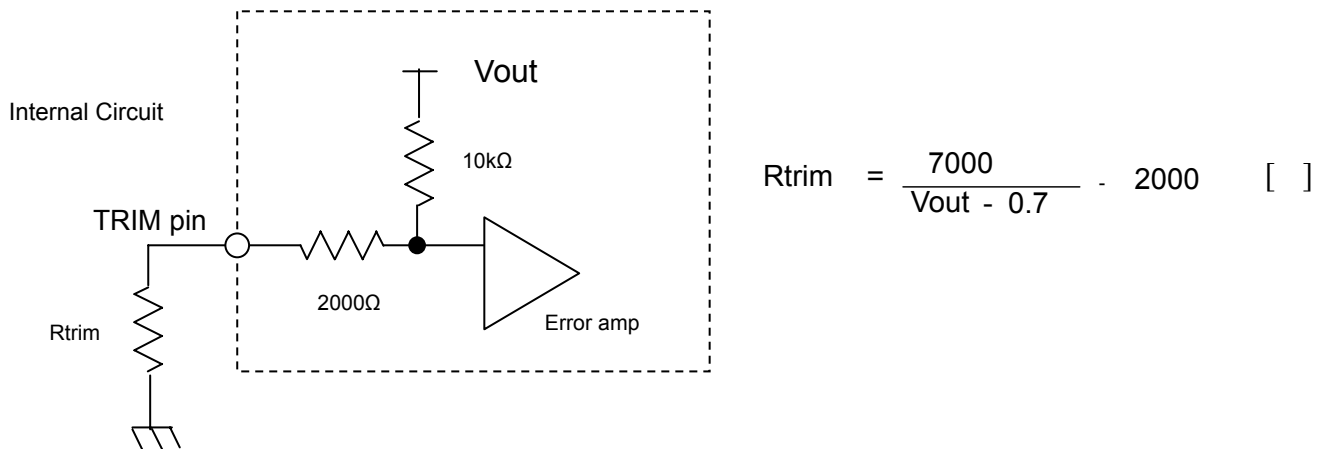

< Rtrim Calculation Example >

Vout(V)	Calculated Rtrim(Ω)	Rtrim Example(Ω)
3.3	692.3	680 + 12
2.5	1888.9	1500 + 390
1.8	4363.6	3900 + 470
1.5	6750	5600 + 1200
1.2	12000	12000
1.0	21333.3	18000 + 3300 + 33
0.8	68000	68000
0.7	∞	Open

9.2.2. ON/OFF control

Using the ON/OFF feature, the operation of this product can be disabled without removal of the input voltage. Sequencing of a power supply system and power-saving control can be easily achieved using this function.

To avoid the influence with the UVLO threshold difference (Rising /Falling UVLO Threshold shown in 9.1.1), when starting or stopping by Vin increasing or decreasing in case of parallel operation. We recommend the ON/OFF control.

When ON/OFF-pin(7pin) is left open Output Voltage =ON
 When ON/OFF-pin(7pin) is connected to GND Output Voltage =OFF

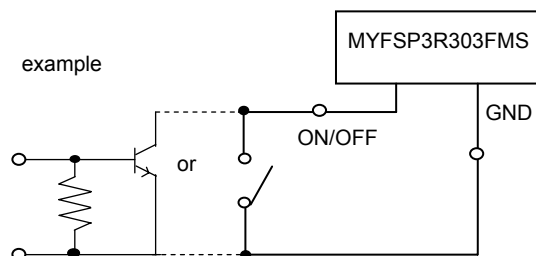

⚠ Note:

1. This datasheet is downloaded from the website of Murata Manufacturing co., ltd. Therefore, it's specifications are subject to change or our products in it may be discontinued without advance notice. Please check with our sales representatives or product engineers before ordering.
2. This datasheet has only typical specifications because there is no space for detailed specifications. Therefore, please approve our product specifications or transact the approval sheet for product specifications before ordering.

9.2.3. Output voltage sensing

By connecting the SENSE-pin to the load, the output voltage drop due to the PCB wiring may be compensated for (within 10cm).

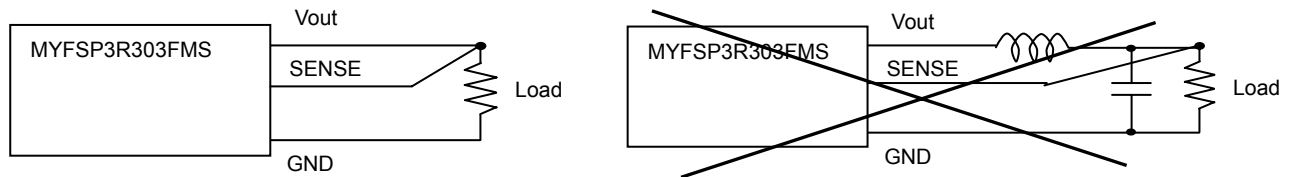

Please do NOT connect SENSE-pin to the output of LC filter that is set to the Vout line. When using this way, this product will not operate properly.

< Caution >

Please connect SENSE-pin to Vout-pin nearby the product, if sense function is not used.

9.2.4. Power Good Function

Power Good Detection output is sent when the DC-DC converter begins the output operation, and it becomes a range of Power Good Detection Range shown in 9.1.3. PGOOD pin is open drain output and it has internal ON resistance shown in section 9.1.2.

The output voltage is a range of Power Good Detection Range : PGOOD is open.

The output voltage is not a range of Power Good Detection Range : Internal ON resistance shown in 9.1.2 is connected between PGOOD-pin and GND-pin.

9.2.5. Parallel Operation.

This product can easily increase the output current by the parallel operation, when setting each output voltage to the same by the function of Trimming (Adjusting) the Output Voltage. The maximum number connecting DC-DC converters is 3pcs of parallel operation. Please connect the each terminal - Vin, Vout, GND, ISHARE, PGOOD, ON/OFF and PO mutually, and connect Rtrim between TRIM-pin and GND-pin respectively. If the ON/OFF or Power good function is not used, PGOOD or ON/OFF terminal can be used by the opening.

< Caution >

Please do not use the Output Voltage sensing and connect SENSE-pin to Vout-pin nearby the product, if you drive in parallel.

⚠ **Note:**

1. This datasheet is downloaded from the website of Murata Manufacturing co., ltd. Therefore, it's specifications are subject to change or our products in it may be discontinued without advance notice. Please check with our sales representatives or product engineers before ordering.
2. This datasheet has only typical specifications because there is no space for detailed specifications. Therefore, please approve our product specifications or transact the approval sheet for product specifications before ordering.

9.2.5.1. The application of parallel operation with plural DC-DC converters (n=2)

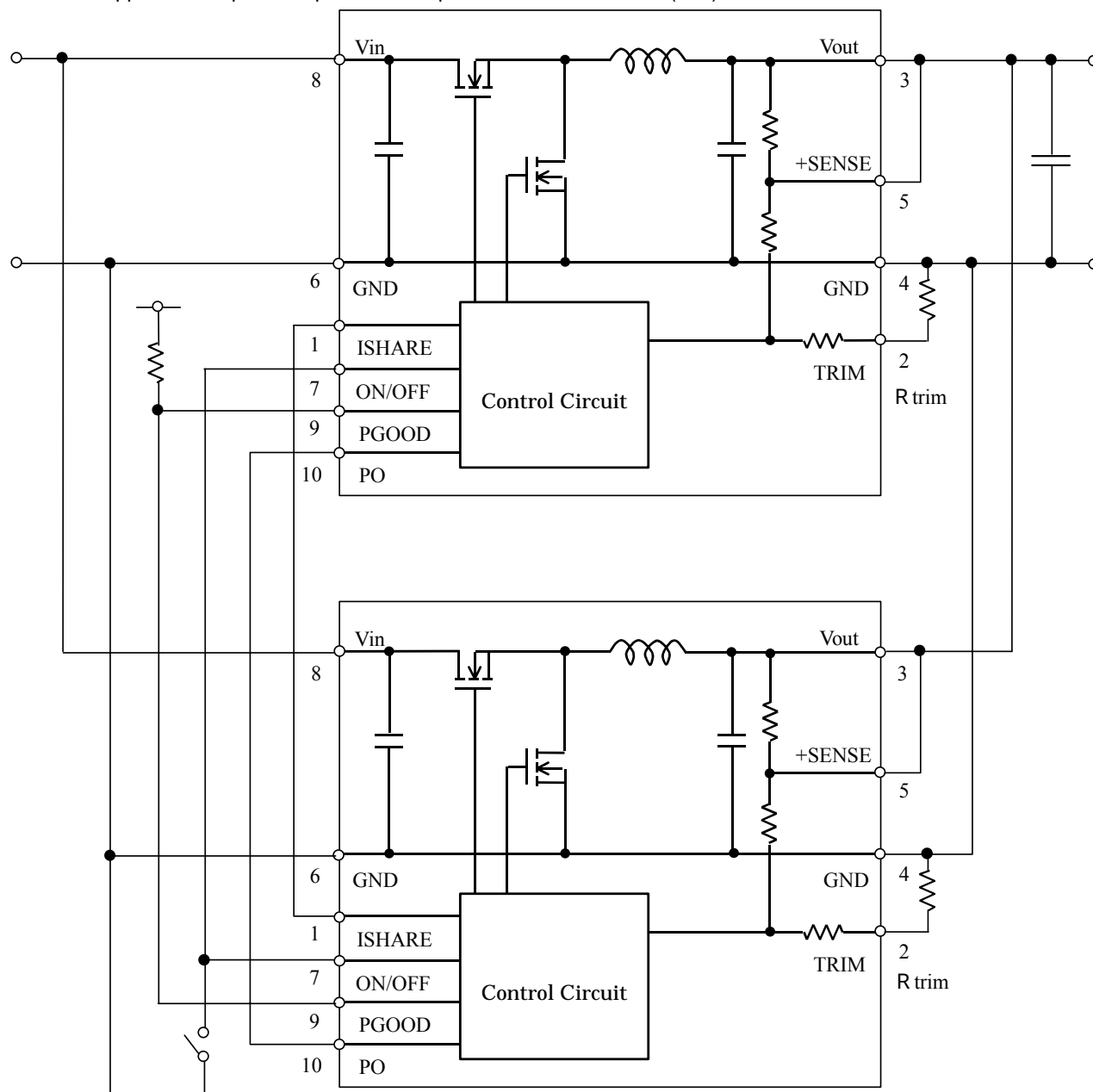

9.2.6. Current share

For the parallel operation of multiple DC-DC converters the output current valance of each converter may be improved by inter-connecting the ISHARE-pins between the parallel devices.

However, please consider so that the exogenous noise should not influence, and do not impress the voltage from the outside to wiring that connects the terminal ISHARE mutually. And please note that the output current is limited by Thermal Derating shown in 9.1.4.. The maximum number connecting DC-DC converters is 3pcs of parallel operation. Please contact us when more than these figures.

9.2.7. Synchronous Turn-off

All of the DC-DC converters are interrupted (hiccup mode operation) when any one is halted with over current protection or over temperature protection, with connecting all PO pins for the application of parallel operation with plural DC-DC converters. However, please consider so that the exogenous noise should not influence, and do not impress the voltage from the outside to wiring that connects the terminal PO mutually. The maximum number connecting DC-DC converters is 3pcs of parallel operation. Please contact us when more than these figures.

9.2.8. Over Temperature Protection

The DC-DC converters thermally shut down(hiccup mode operation) when junction temperature of a control IC reaches to 175°C typically.

⚠ Note:

1. This datasheet is downloaded from the website of Murata Manufacturing co., ltd. Therefore, it's specifications are subject to change or our products in it may be discontinued without advance notice. Please check with our sales representatives or product engineers before ordering.
2. This datasheet has only typical specifications because there is no space for detailed specifications. Therefore, please approve our product specifications or transact the approval sheet for product specifications before ordering.

9.3. Reliability

9.3.1. Humidity

According to JIS-C-0022.

40 ± 2°C, 90 to 95%RH, 100 hours. Leave for 4 hours at room temperature.

No damage in appearance and no deviation from electrical characteristics (section 9.1.).

9.3.2. Temperature Cycles

Repeat cycle 5 times. Leave 2 hours at room temp.

No damage in appearance and no deviation from electrical characteristics (section 9.1.).

Step	Condition	Time
1	-40°C ± 3°C	30 minutes
2	Room Temp.	5-10 minutes
3	+85°C ± 2°C	30 minutes
4	Room Temp.	5-10 minutes

9.3.3. Vibration

10 to 55Hz, 1.5mm amplitude (1minute cycle), 1 hour for each of X, Y, Z directions.

No damage in appearance and no deviation from electrical characteristics (section 9.1.).

9.3.4. Mechanical Shock

20G, 1 time for each X, Y, Z directions.

No damage in appearance and no deviation from electrical characteristics (section 9.1.).

10. Test Circuit

In the following test circuit, the initial values under item 9.1. should be met.

10.1. General Measure Circuit

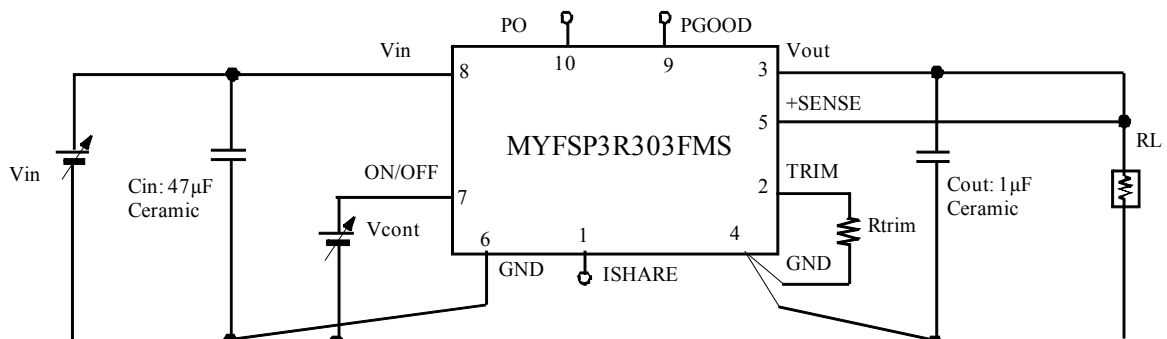

Cin : 47µF / 6.3V Ceramic Capacitor
Cout : 1µF / 10V Ceramic Capacitor

Please make sure to place Cin and Cout nearby input and output terminal of DC-DC converter.

⚠ Note:

1. This datasheet is downloaded from the website of Murata Manufacturing co., ltd. Therefore, it's specifications are subject to change or our products in it may be discontinued without advance notice. Please check with our sales representatives or product engineers before ordering.
2. This datasheet has only typical specifications because there is no space for detailed specifications. Therefore, please approve our product specifications or transact the approval sheet for product specifications before ordering.

10.2. Ripple Noise Measurement Circuit

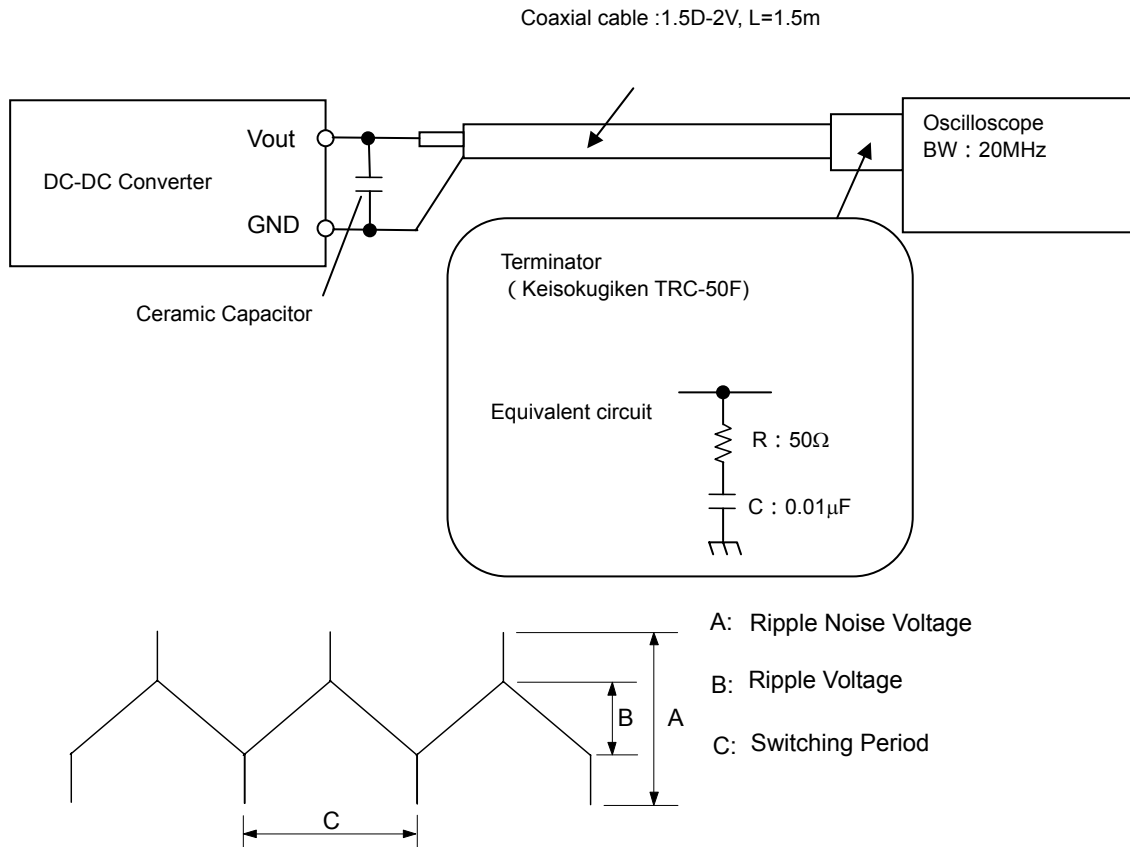

10.3. Land Pattern Recommendation

Both input-side and output side, please make the wiring loop between plus and minus as small as possible. The influence of a leakage inductance can be reduced.

Please separate GND(Vin) line from GND(Vout) line. The following figure is an example of recommended PCB design. Please consider so that the exogenous noise should not influence, and do not impress the voltage from the outside to wiring that connects the terminal ISHARE mutually.

Please make the power line pattern as wide and short as possible. The following figure is an example of recommendable PCB design.

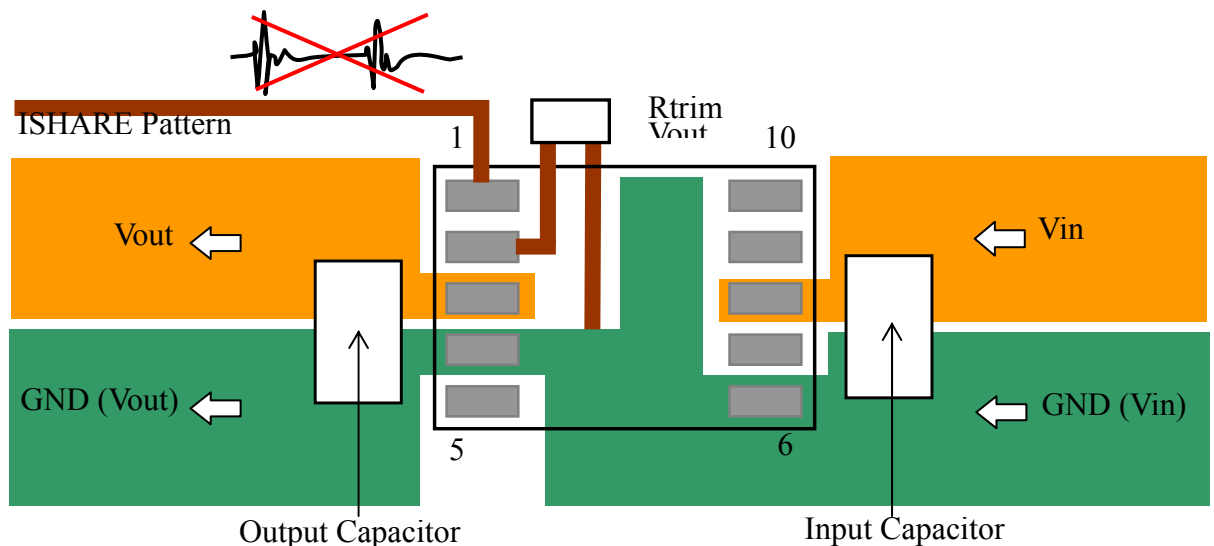

⚠ Note:

1. This datasheet is downloaded from the website of Murata Manufacturing co., ltd. Therefore, it's specifications are subject to change or our products in it may be discontinued without advance notice. Please check with our sales representatives or product engineers before ordering.
2. This datasheet has only typical specifications because there is no space for detailed specifications. Therefore, please approve our product specifications or transact the approval sheet for product specifications before ordering.

11. Packaging Specification

11.1. Emboss Tape Dimensions

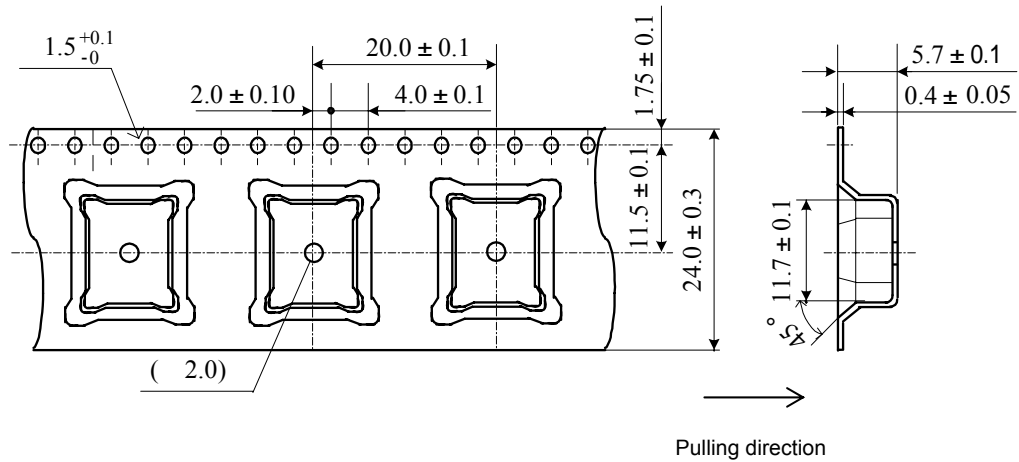

11.2. Real Dimension

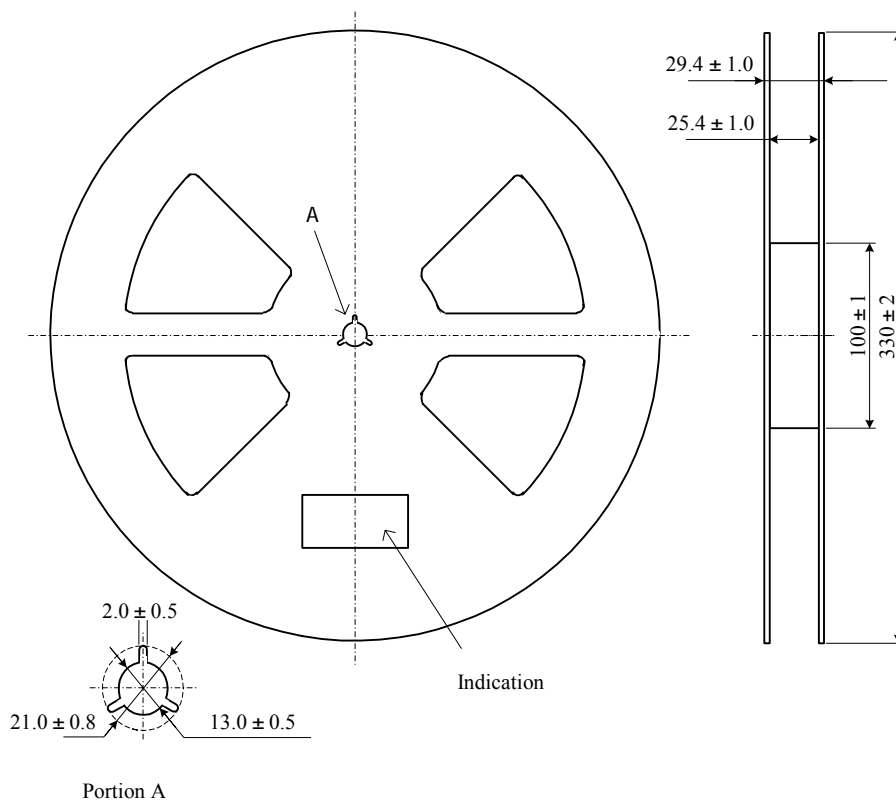

⚠ Note:

1. This datasheet is downloaded from the website of Murata Manufacturing co., ltd. Therefore, it's specifications are subject to change or our products in it may be discontinued without advance notice. Please check with our sales representatives or product engineers before ordering.
2. This datasheet has only typical specifications because there is no space for detailed specifications. Therefore, please approve our product specifications or transact the approval sheet for product specifications before ordering.

11.3. Taping Specification

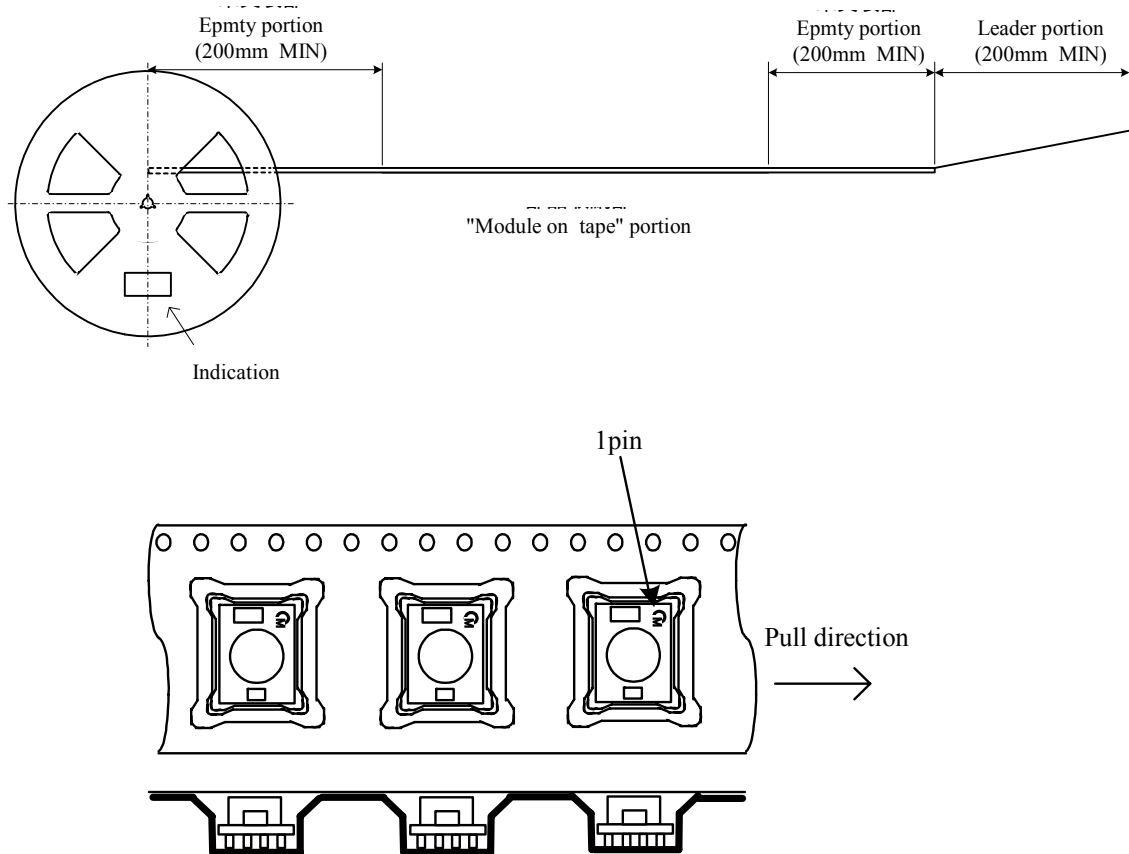

The module is oriented with coil on top and pins on the bottom sides.

11.4. Note

1. The adhesive strength of the protective tape must be within 0.1-1N.
2. Each reel contains 500pcs.
3. No vacant pocket in "Module on tape" section.
4. The reel is labeled with Murata part number and quantity.
5. The color of reel is not designated.

⚠ Note:

1. This datasheet is downloaded from the website of Murata Manufacturing co., ltd. Therefore, it's specifications are subject to change or our products in it may be discontinued without advance notice. Please check with our sales representatives or product engineers before ordering.
2. This datasheet has only typical specifications because there is no space for detailed specifications. Therefore, please approve our product specifications or transact the approval sheet for product specifications before ordering.

11.5. Packing form

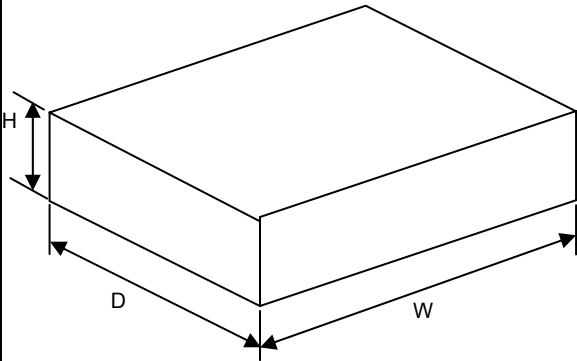
Item	Specification
Packaging form typical classification	Box
Dimensions of packaging form (typ.)	 <p> $W = 345 \text{ (mm)}$ $D = 345 \text{ (mm)}$ $H = 95 \text{ (mm)}$ </p>
The number of products in packaging form	1000 (p c s)
Mass of one product	0.76 typ. (g)
Remark If the products have fraction, may not follow this specification.	

12. Production factory

Komatsu Murata Mfg.Co., Ltd.

Kanazu Murata Mfg. Co., Ltd.

Wakura Murata Mfg. Co., Ltd.

⚠ **Note:**

1. This datasheet is downloaded from the website of Murata Manufacturing co., ltd. Therefore, it's specifications are subject to change or our products in it may be discontinued without advance notice. Please check with our sales representatives or product engineers before ordering.
2. This datasheet has only typical specifications because there is no space for detailed specifications. Therefore, please approve our product specifications or transact the approval sheet for product specifications before ordering.

13. Caution

1. Be sure to provide an appropriate fail-safe function on your product to prevent secondary damage that may be caused due to abnormal functional or failure of this product.
2. Inrush current protection is not a feature of this product.
3. Please connect the input terminals with the correct polarity. If an error in polarity connection is made this product may be damaged. If this product is damaged internally, an elevated input current may flow, and so this product may exhibit an abnormal temperature rise, or your product may be damaged. Please add a diode and fuse per the following diagram to protect them.

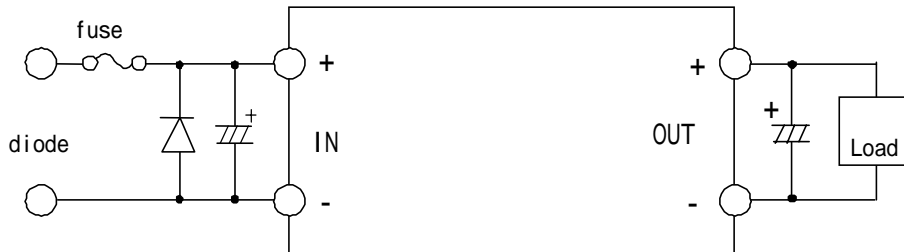

Please select diode and fuse after confirming the operation of your product.

4. Limitation of Application

Please contact us before using this product for the applications listed below which require especially high reliability for the prevention of defects, which might directly cause damage to the third party's life, body or property.

- Aircraft equipment
- Aerospace equipment
- Undersea equipment
- Power plant control equipment
- Medical equipment
- Transportation equipment (vehicles, trains, ships, etc.)
- Traffic signal equipment
- Disaster prevention /crime prevention equipment
- Any other application of similar complexity and/or reliability requirements to the applications listed above.

14. Notice

14.1. Soldering

14.1.1. Flux

Please solder this product with Rosin Flux that contains of 0.2wt% or less chlorine.
Please do not use high activity acid flux or water-soluble flux as they may reduce the reliability of this product.

Note:

1. This datasheet is downloaded from the website of Murata Manufacturing co., ltd. Therefore, it's specifications are subject to change or our products in it may be discontinued without advance notice. Please check with our sales representatives or product engineers before ordering.
2. This datasheet has only typical specifications because there is no space for detailed specifications. Therefore, please approve our product specifications or transact the approval sheet for product specifications before ordering.

14. 2. Cleaning

Please use no-cleaning type flux and do not wash this product.

14.3. Storage

14.3.1. Please store the products in room where the temperature/humidity is stable and direct sunlight cannot come in, and use the products within 6 months after delivery.

Please avoid damp and heat or such places where the temperature greatly changes, as water may condense on this product, and the quality of characteristics may be reduced, and/or be the solderability may be degraded.

If this product needs to be stored for a long time (more than 1 year), this product may be degraded in solderability and/or corroded. Please test the solderability of this product regularly.

Baking before reflow process is unnecessary to store the products under 30 ± 5%RH or less up to 6 months.

In case the storage condition is over above mentioned, if these are unpacked condition, please bake them at 125 ± 5 /24hour. If these are packed in a tape, please bake them before soldering at 60 ± 5 /168hour.

14.3.2. Please do not store this product in places such as :

A dusty place, a place exposed directly to sea breeze, or in an atmosphere containing corrosive gas (Cl₂,NH₃,SO₂,NOX and so on).

14. 4. Operational Environment and Operational Conditions

14.4.1. Operational Environment

This product is not water-, chemical- or corrosion-proof.

In order to prevent leakage of electricity and abnormal temperature rise of the product,do not operate under the following environmental conditions:

- (1) An atmosphere containing corrosive gas (Cl₂, NH₃, SO₂, NOX and so on)
- (2) A high-dust environment
- (3) Under the exposure of direct sunlight
- (4) A location where the likelihood of exposure to water or water condensation exists.
- (5) A location exposed to ocean air
- (6) Any locations similar to the above

14.4.2. Operational Conditions

Please use this product within specified values (power supply, temperature, input, output and load condition, and so on). If the product is exposed to conditions outside of the specified values reliability of the product may be adversely effected.

14.4.3. Note prior to use

Diminished reliability and/ or failure may result if the product is exposed to a high-level static charge, over-rated voltage or reverse voltage. Please avoid the following conditions be avoided prior to use of the product:

- (1) Supply of power outside of rated values (see section 8)
- (2) Supply of reverse power or inadequate connection of a 0 V(DC)line
- (3) Electrostatic discharge from production line and/ or operator
- (4) Electrification of the product from electrostatic induction
- (5) Excessive mechanical shock

14.5. Transportation

Murata recommends that when transporting this product, it be packed so as to avoid damage by mechanical vibration or exposure to adverse conditions such as ocean air, high humidity. It is additionally recommended that appropriate instructions and guidelines be communicated to carriers to prevent exposure to these same conditions.

15. Note

1. Murata recommends that customers ensure that the evaluation and testing of these devices are completed with this product actually assembled on their product.

2. All the items and parameters in this product specification have been prescribed on the premise that Murata's product is used for the purpose, under the condition and in the environment mutually agreed upon.

**This document is for reference only and subject to revision without prior of subsequent notice.
Please contact Murata for latest documentation.**

Note:

1. This datasheet is downloaded from the website of Murata Manufacturing co., ltd. Therefore, it's specifications are subject to change or our products in it may be discontinued without advance notice. Please check with our sales representatives or product engineers before ordering.
2. This datasheet has only typical specifications because there is no space for detailed specifications. Therefore, please approve our product specifications or transact the approval sheet for product specifications before ordering.



Компания «ЭлектроПласт» предлагает заключение долгосрочных отношений при поставках импортных электронных компонентов на взаимовыгодных условиях!

Наши преимущества:

- Оперативные поставки широкого спектра электронных компонентов отечественного и импортного производства напрямую от производителей и с крупнейших мировых складов;
- Поставка более 17-ти миллионов наименований электронных компонентов;
- Поставка сложных, дефицитных, либо снятых с производства позиций;
- Оперативные сроки поставки под заказ (от 5 рабочих дней);
- Экспресс доставка в любую точку России;
- Техническая поддержка проекта, помощь в подборе аналогов, поставка прототипов;
- Система менеджмента качества сертифицирована по Международному стандарту ISO 9001;
- Лицензия ФСБ на осуществление работ с использованием сведений, составляющих государственную тайну;
- Поставка специализированных компонентов (Xilinx, Altera, Analog Devices, Intersil, Interpoint, Microsemi, Aeroflex, Peregrine, Syfer, Eurofarad, Texas Instrument, Miteq, Cobham, E2V, MA-COM, Hittite, Mini-Circuits, General Dynamics и др.);

Помимо этого, одним из направлений компании «ЭлектроПласт» является направление «Источники питания». Мы предлагаем Вам помощь Конструкторского отдела:

- Подбор оптимального решения, техническое обоснование при выборе компонента;
- Подбор аналогов;
- Консультации по применению компонента;
- Поставка образцов и прототипов;
- Техническая поддержка проекта;
- Защита от снятия компонента с производства.



Как с нами связаться

Телефон: 8 (812) 309 58 32 (многоканальный)

Факс: 8 (812) 320-02-42

Электронная почта: org@eplast1.ru

Адрес: 198099, г. Санкт-Петербург, ул. Калинина, дом 2, корпус 4, литера А.