

Quad power amplifier with integrated step-up converter

Features

- Multipower BCD technology
- DMOS power output
- Non-switching high efficiency amplifier
- Switching high efficiency voltage converter
- High output power capability:
 - 4 x 41 W max @ $V_s = 14.4$ V
 - 4 x 59 W @ $V_s = 14.4$ V and PWM = 17.5 V
- Full I²C bus driving:
 - Standby
 - Independent front/rear soft play/mute
 - Selectable gain 26 dB - 12 dB (for low noise line output function)
 - High efficiency enable/disable
 - Voltage converter enable/disable
 - Regulated voltage selection
 - Switching frequency selection
- Hardware mute function
- Full fault protection
- DC offset detection
- Four independent short circuit protection
- Clipping detector with selectable threshold (1 % / 10 %) via I²C bus

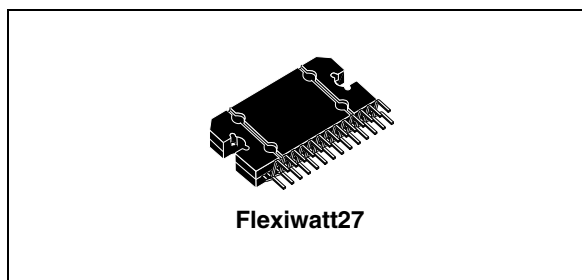

Description

The TDA7565 is a new BCD technology quad bridge type of car radio amplifier in Flexiwatt27 package specially intended for car radio applications.

Thanks to the DMOS output stage the TDA7565 has a very low distortion allowing a clear powerful sound.

The built-in voltage converter control block assures a very high output power with an extremely low number of added components.

Furthermore, the converter makes the TDA7565 compliant to the most recent OEM specifications for low voltage operation (so called 'start-stop' battery profile during engine stop), helping car manufacturers to reduce the overall emissions and thus contributing to environment protection.

Table 1. Device summary

Order code	Package	Packing
TDA7565	Flexiwatt27	Tube

Contents

1	Block and pin connection diagrams	5
2	Electrical specification	6
2.1	Absolute maximum ratings	6
2.2	Thermal data	6
2.3	Electrical characteristics	6
3	I²C bus interface	10
3.1	Data validity	10
3.2	Start and stop conditions	10
3.3	Byte format	10
3.4	Acknowledge	10
4	Software specifications	12
5	Examples of bytes sequence	15
6	Low voltage "start-stop" operation	16
7	Package information	17
8	Revision history	18

List of tables

Table 1.	Device summary	1
Table 2.	Absolute maximum ratings	6
Table 3.	Thermal data	6
Table 4.	Electrical characteristics	6
Table 5.	Chip address	12
Table 6.	IB1	12
Table 7.	IB2	13
Table 8.	DB1	13
Table 9.	DB2	13
Table 10.	DB3	14
Table 11.	DB4	14
Table 12.	Document revision history	18

List of figures

Figure 1.	Block diagram	5
Figure 2.	Pin connection (top view)	5
Figure 3.	Demoboard schematic	9
Figure 4.	Data validity on the I2C bus	10
Figure 5.	Timing diagram on the I2C bus.	11
Figure 6.	Acknowledge on the I2C bus	11
Figure 7.	Worst case condition for a start-stop system diagram	16
Figure 8.	Flexiwatt27 (vertical) mechanical data and package dimensions.	17

1 Block and pin connection diagrams

Figure 1. Block diagram

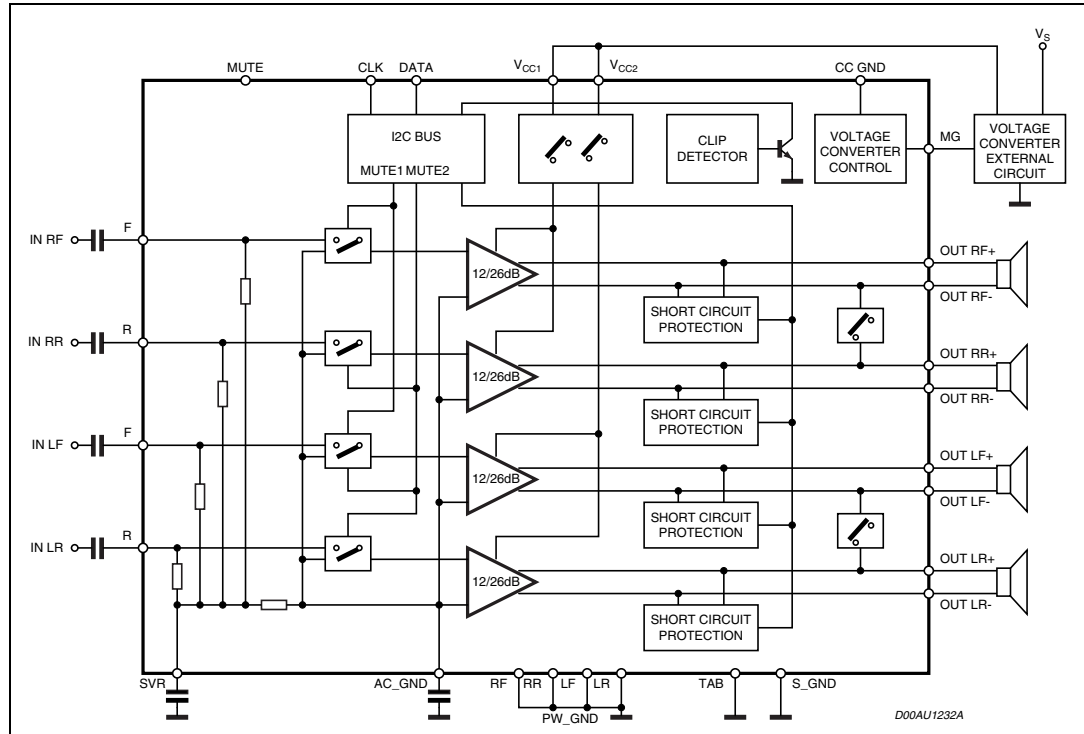
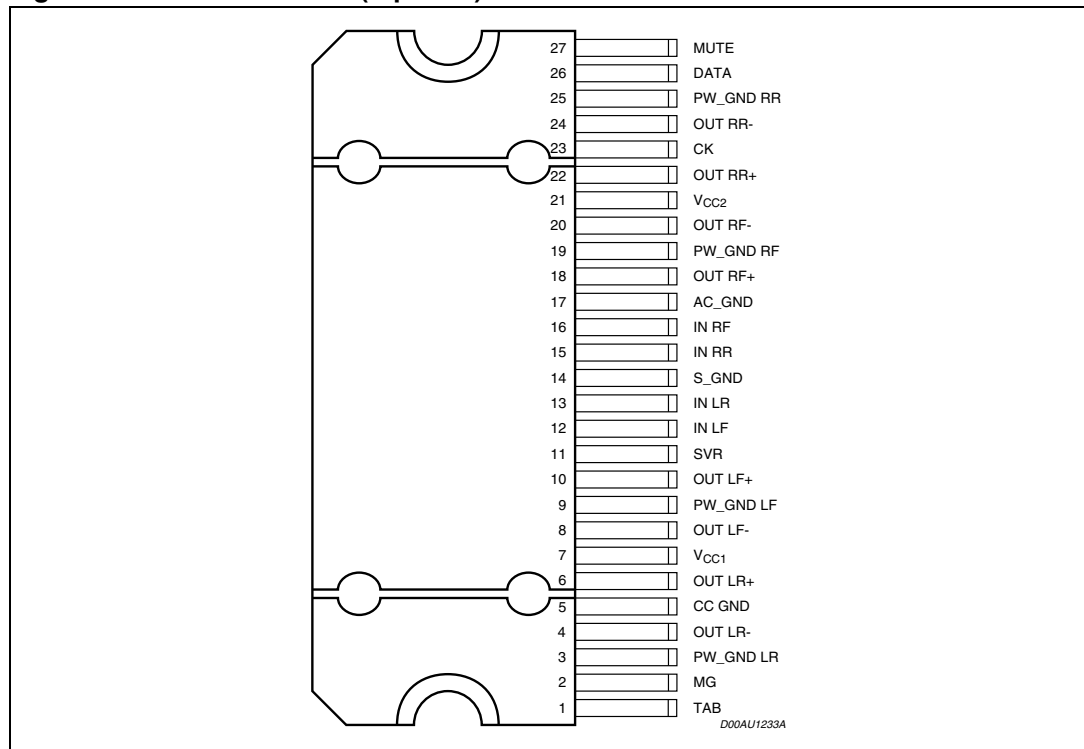

Figure 2. Pin connection (top view)



2 Electrical specification

2.1 Absolute maximum ratings

Table 2. Absolute maximum ratings

Symbol	Parameter	Value	Unit
$V_{opc\ OFF}$	Operating supply voltage, converter off	18	V
$V_{opc\ ON}$	Operating supply voltage, converter on	25	V
V_S	DC supply voltage	28	V
V_{peak}	Peak supply voltage (for $t = 50\ ms$)	50	V
V_{CK}	CK pin voltage	6	V
V_{DATA}	Data pin voltage	6	V
I_O	Output peak current (not repetitive $t = 100\ \mu s$)	8	A
I_O	Output peak current (repetitive $f > 10\ Hz$)	6	A
P_{tot}	Power dissipation $T_{case} = 70\ ^\circ C$	80	W
T_{stg}, T_j	Storage and junction temperature	-55 to 150	$^\circ C$

2.2 Thermal data

Table 3. Thermal data

Symbol	Description	Value	Unit
$R_{th\ j-case}$	Thermal resistance junction to case Max.	1	$^\circ C/W$

2.3 Electrical characteristics

Refer to the test circuit, $V_S = 14.4\ V$; $R_L = 4\ \Omega$; $f = 1\ kHz$; voltage converter disabled (VC_{Off}); $T_{amb} = 25\ ^\circ C$; unless otherwise specified.

Table 4. Electrical characteristics

Symbol	Parameter	Test condition	Min.	Typ.	Max.	Unit
Power amplifier						
V_S	Supply voltage range	-	8	-	18	V
I_d	Total quiescent drain current	-	-	250	300	mA
I_d	Total quiescent drain current (VC_{on})	-	-	350	-	mA
P_O	Output power (VC_{off}) $V = 14.4\ V$	Max power ⁽¹⁾	-	41	-	W
		THD = 10 %	22	27	-	W
		THD = 1 %	18	22	-	W

Table 4. Electrical characteristics (continued)

Symbol	Parameter	Test condition	Min.	Typ.	Max.	Unit
P _O	Output power (V _{C_{on}}) V = 14.4V, PWM = 17.5V	Max power ⁽¹⁾	-	59	-	W
		THD = 10 %	32	39	-	W
		THD = 1 %	25	31	-	W
THD	Total harmonic distortion	P _O = 1 W to 12 W; STDmode HE mode; P _O = 1-2 W HE mode; P _O = 4-12 W	-	0.03 0.03 0.1	0.1	% % %
		P _O = 1-12 W, f = 10 kHz	-	0.15	0.5	%
C _T	Cross talk	f = 1 kHz to 10 kHz, R _G = 600 Ω	50	55	-	dB
R _{IN}	Input impedance	-	60	100	130	KΩ
G _{V1}	Voltage gain 1	-	25.5	26	26.5	dB
ΔG _{V1}	Voltage gain match 1	-	-1	-	1	dB
G _{V2}	Voltage gain 2	-	11.5	12	12.5	dB
ΔG _{V2}	Voltage gain match 2	-	-1	-	1	dB
E _{IN1}	Output noise voltage 1	R _g = 600 Ω; G _V = 26 dB filter 20 Hz to 22 kHz	-	60	70	μV
E _{IN2}	Output noise voltage 2	R _g = 600 Ω; G _V = 26 dB filter 20 Hz to 12 kHz	-	15	25	μV
SVR	Supply voltage rejection	f = 100 Hz to 10 kHz; V _r = 1V pk; R _g = 600 Ω	50	60	-	dB
BW	Power bandwidth	(-3 dB)	75	-	-	KHz
A _{SB}	Standby attenuation	-	70	100	-	dB
I _{SB}	Standby current	-	-	-	50	μA
A _M	Mute attenuation	-	70	90	-	dB
V _{OS}	Offset voltage	Mute and play	-100	-	100	mV
V _{AM}	Min. supply voltage threshold	-	6.5	7	7.5	V
	Slew rate	-	1.5	-	-	V/μs
T _{ON}	Turn on delay	D2/D1 (IB1) 0 to 1	-	10	40	ms
T _{OFF}	Turn off delay	D2/D1 (IB1) 1 to 0	-	10	40	ms
-	Thermal foldback junction temperature	-	155	170	185	°C
CD _{THD}	Clip det thd. level	D0 (IB1) = 0	0	1	2	%
		D0 (IB1) = 1	5	10	15	%
V _O	Offset detection	Power amplifier = play AC Input = 0	±1.5	±2	±2.5	V
T _{hw}	Thermal warning	-	-	165	-	°C

Table 4. Electrical characteristics (continued)

Symbol	Parameter	Test condition	Min.	Typ.	Max.	Unit
I²C bus interface						
f _{SCL}	Clock frequency	-	-	-	400	KHz
V _{IL}	Input low voltage	-	-	-	1.5	V
V _{IH}	Input high voltage	-	2.3	-	-	V
V _{Min(pin27)}	Mute in threshold voltage	Amp. mute	-	-	1.5	V
V _{Mout(pin27)}	Mute out threshold voltage	-	3.5	-	-	V
A _{M(pin 27)}	Mute attenuation	-	80	90	-	-
Voltage converter						
V _{CC1} , V _{CC2}	Converter output voltage (VC = ON)	V _S = 14 V D3 (IB2) = 0; D6 (IB2) = 0 D3 (IB2) = 1; D6 (IB2) = 0 D3 (IB2) = 0; D6 (IB2) = 1 D3 (IB2) = 1; D6 (IB2) = 1	-	15 16.5 17.5 18.5	-	V
F _s	Voltage converter switching frequency	D6 (IB1) = 0; D7 (IB1) = 0 D6 (IB1) = 1; D7 (IB1) = 0 D6 (IB1) = 0; D7 (IB1) = 1 D6 (IB1) = 1; D7 (IB1) = 1	90 135 230 360	-	120 175 300 470	kHz
V _{mgl}	MOS gate output low voltage	I _o = 200 mA	-	1	2	V
V _{mgh}	MOS gate output high voltage	I _o = 20 mA	-	11	-	V
		I _o = 200 mA	-	9.5	-	V
V _{mgclamp}	MOS gate output clamp voltage	I _o = 5 mA	-	11.5	-	V
t _f	Fall time	C _o = 1 nF	-	20	-	ns
t _r	Rise time	C _o = 1 nF	-	50	-	ns
V _{mgl} (V _{Coff})	MOS gate output voltage with voltage converter disabled	I _o = 5 mA	-	-	0.5	V

1. Saturated square wave output.

Figure 3. Demoboard schematic

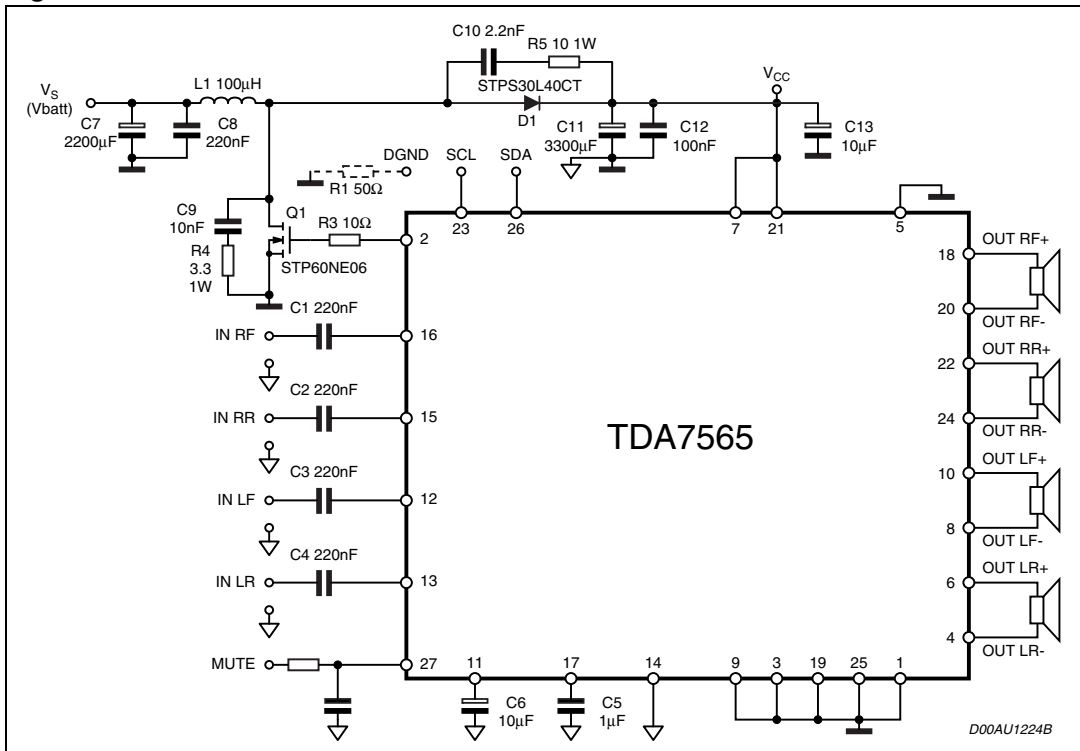

3 I²C bus interface

Data transmission from microprocessor to the TDA7565 and vice versa takes place through the 2 wires I²C bus interface, consisting of the two lines SDA and SCL (pull-up resistors to positive supply voltage must be connected).

3.1 Data validity

As shown by [Figure 4](#), the data on the SDA line must be stable during the high period of the clock. The HIGH and LOW state of the data line can only change when the clock signal on the SCL line is LOW.

3.2 Start and stop conditions

As shown by [Figure 5](#) a start condition is a high to low transition of the SDA line while SCL is HIGH. The stop condition is a low to high transition of the SDA line while SCL is high.

3.3 Byte format

Every byte transferred to the SDA line must contain 8 bits. Each byte must be followed by an acknowledge bit. The MSB is transferred first.

3.4 Acknowledge

The transmitter* puts a resistive high level on the SDA line during the acknowledge clock pulse (see [Figure 6](#)). The receiver** the acknowledges has to pull-down (low) the SDA line during the acknowledge clock pulse, so that the SDA line is stable low during this clock pulse.

* Transmitter

- master (μ P) when it writes an address to the TDA7565
- slave (TDA7565) when the μ P reads a data byte from TDA7565

** Receiver

- slave (TDA7565) when the μ P writes an address to the TDA7565
- master (μ P) when it reads a data byte from TDA7565

Figure 4. Data validity on the I²C bus

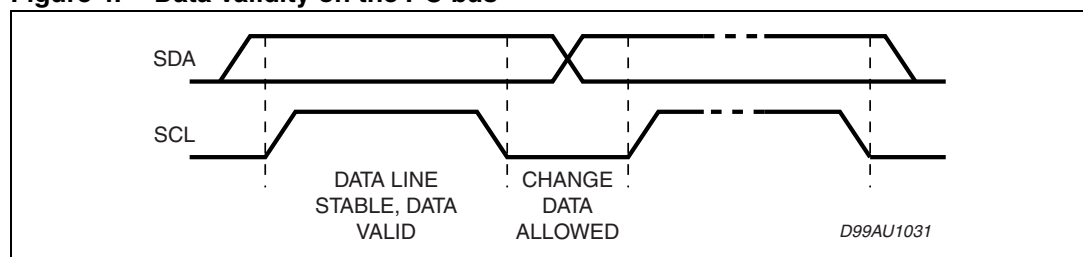

Figure 5. Timing diagram on the I²C bus

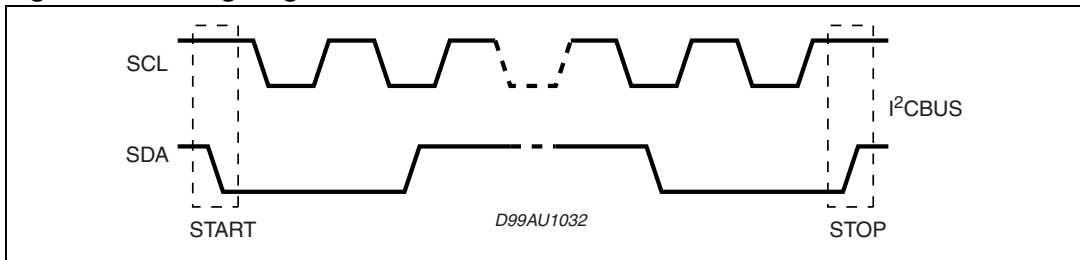
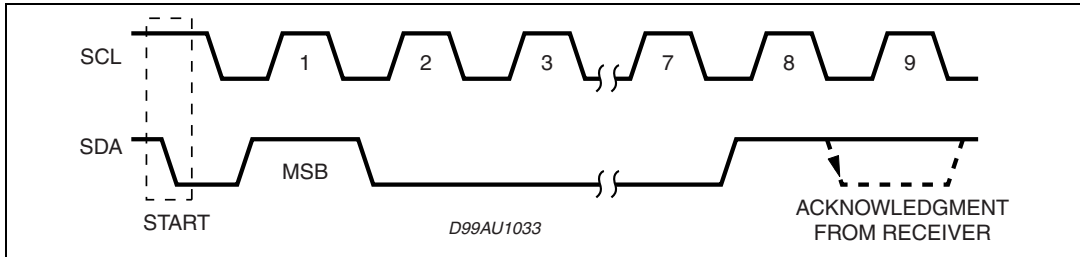

Figure 6. Acknowledge on the I²C bus



4 Software specifications

All the functions of the TDA7565 are activated by I²C interface.

The bit 0 of the "ADDRESS BYTE" defines if the next bytes are write instruction (from μ P to TDA7565) or read instruction (from TDA7565 to μ P).

Table 5. Chip address

Bit	Instruction
D7	Address bit
D6	Address bit
D5	Address bit
D4	Address bit
D3	Address bit
D2	Address bit
D1	Address bit
D0(R/W)	Read/Write bit 0 = Write instruction 1 = read instruction

If R/W = 0, the μ P sends 2 "Instruction Bytes": IB1 and IB2.

Table 6. IB1

Bit	Instruction
D7	Sel. freq. switch 1
D6	Sel. freq. switch 2
D5	Offset detection start (D5 = 1) Offset detection stop (D5 = 0) (off)
D4	Front channel Gain = 26dB (D4 = 0) Gain = 12dB (D4 = 1)
D3	Rear channel Gain = 26dB (D3 = 0) Gain = 12dB (D3 = 1)
D2	Mute front channels (D2 = 0) Unmute front channels (D2 = 1)
D1	Mute rear channels (D1 = 0) Unmute rear channels (D1 = 1)
D0	CD 1% (D0 = 0) CD 10% (D0 = 1)

Table 7. IB2

Bit	Instruction
D7	Voltage converter enabled (D7 = 1) Voltage converter disabled (D7 = 0)
D6	Regulated voltage selection 1
D5	Test speed
D4	Stand-by on - amplifier not working - (D4 = 0) Stand-by off - amplifier working - (D4 = 1)
D3	Regulated voltage selection 0)
D2	To be forced to "Level 1"
D1	Right channel Power amplifier working in standard mode (D1 = 0) Power amplifier working in Hi Eff. mode(D1 = 1)
D0	Left channel Power amplifier working in standard mode (D0 = 0) Power amplifier working in Hi Eff. mode(D0 = 1)

Table 8. DB1

Bit	Instruction
D7	Thermal warning
D6	X
D5	X
D4	X
D3	X
D2	Offset (LF)
D1	Short circuit protection (CH1)
D0	X

Table 9. DB2

Bit	Instruction
D7	Off status
D6	X
D5	Clip detector output
D4	X
D3	X
D2	Offset (LR)
D1	Short circuit protection (CH2)
D0	X

Table 10. DB3

Bit	Instruction
D7	Standby status
D6	X
D5	X
D4	X
D3	X
D2	Offset (RF)
D1	Short circuit protection (CH3)
D0	X

Table 11. DB4

Bit	Instruction
D7	X
D6	X
D5	X
D4	X
D3	X
D2	Offset (RR)
D1	Short circuit protection (CH4)
D0	X

5 Examples of bytes sequence

1 - Turn-on of the power amplifier with 26 dB gain, mute on, diagnostic defeat, high eff. mode, voltage converter disabled.

Start	Address byte with D0 = 0	ACK	IB1	ACK	IB2	ACK	STOP
			XX00X000		0XX1XX10		

2 - Turn-off of the power amplifier

Start	Address byte with D0 = 0	ACK	IB1	ACK	IB2	ACK	STOP
			XXXXXXXX		XXX0XXX0		

4 - Offset detection procedure start

Start	Address byte with D0 = 0	ACK	IB1	ACK	IB2	ACK	STOP
			XX1XX11X		XXX1XXX0		

5 - Offset detection procedure stop and reading operation.

Start	Address byte with D0 = 1	ACK	DB1	STOP

- The purpose of this test is to check if a D.C. offset (2V typ.) is present on the outputs, produced by input capacitor with anomalous leakage current or humidity between pins.
- The delay from 3 to 4 can be selected by software, starting from 1 ms

6 Low voltage "start-stop" operation

The most recent OEM specification are requiring automatic stop of car engine at traffic lights in order to reduce emissions of polluting substances. The TDA7565, thanks to its integrated switching voltage converter, allows a continuous operation when battery falls down to 6/7 V during such conditions, without producing pop noise. The maximum system power will be reduced accordingly.

The internal converter must be enabled and programmed in order to supply 15 V ($D3 (IB2) = 0$; $D6 (IB2) = 0$). The suggested voltage frequency switching is 150 kHz ($D6 (IB1) = 1$; $D7 (IB1) = 0$).

The following curve is a worst case condition for a start-stop system. The TDA7565, with the switching converter powered on, can sustain this cranking curve without any audio signal interruption.

Figure 7. Worst case condition for a start-stop system diagram

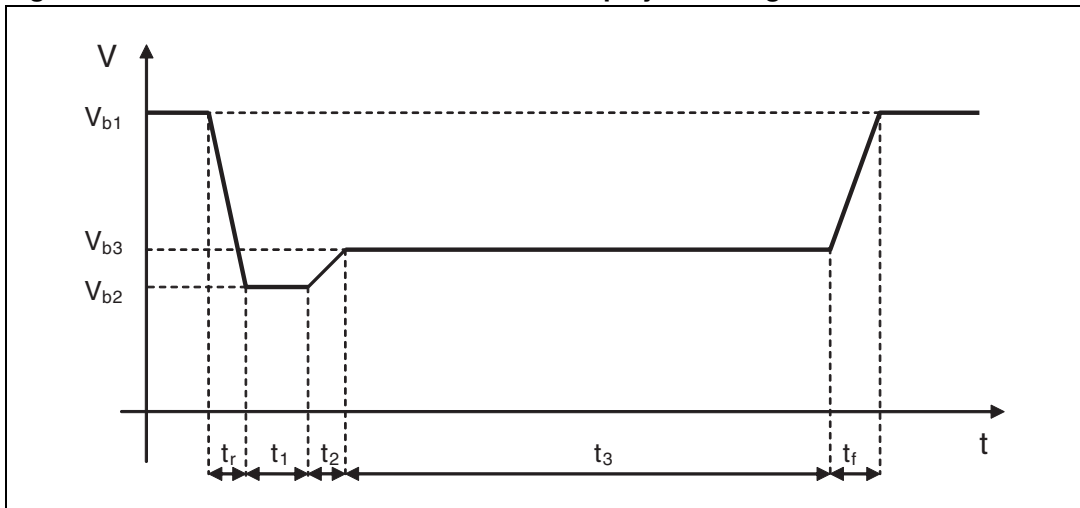

$V_{b1} = 12 \text{ V}$, $V_{b2} = 6 \text{ V}$, $V_{b3} = 7 \text{ V}$

$R_i \leq 0.01 \Omega$ (internal resistor of power supply)

Recovery time from test start to t_r is 1 s

$t_r = 2 \text{ ms}$

$t_1 = 1 \text{ ms}$ (the shortest time, at cranking simulation power supply, is 5 ms)

$t_2 = 15 \text{ ms}$

$t_3 = 1 \text{ s}$

$t_f = 0.5 \text{ s}$

7 Package information

In order to meet environmental requirements, ST offers these devices in different grades of ECOPACK® packages, depending on their level of environmental compliance. ECOPACK® specifications, grade definitions and product status are available at: www.st.com.

ECOPACK® is an ST trademark.

Figure 8. Flexiwatt27 (vertical) mechanical data and package dimensions

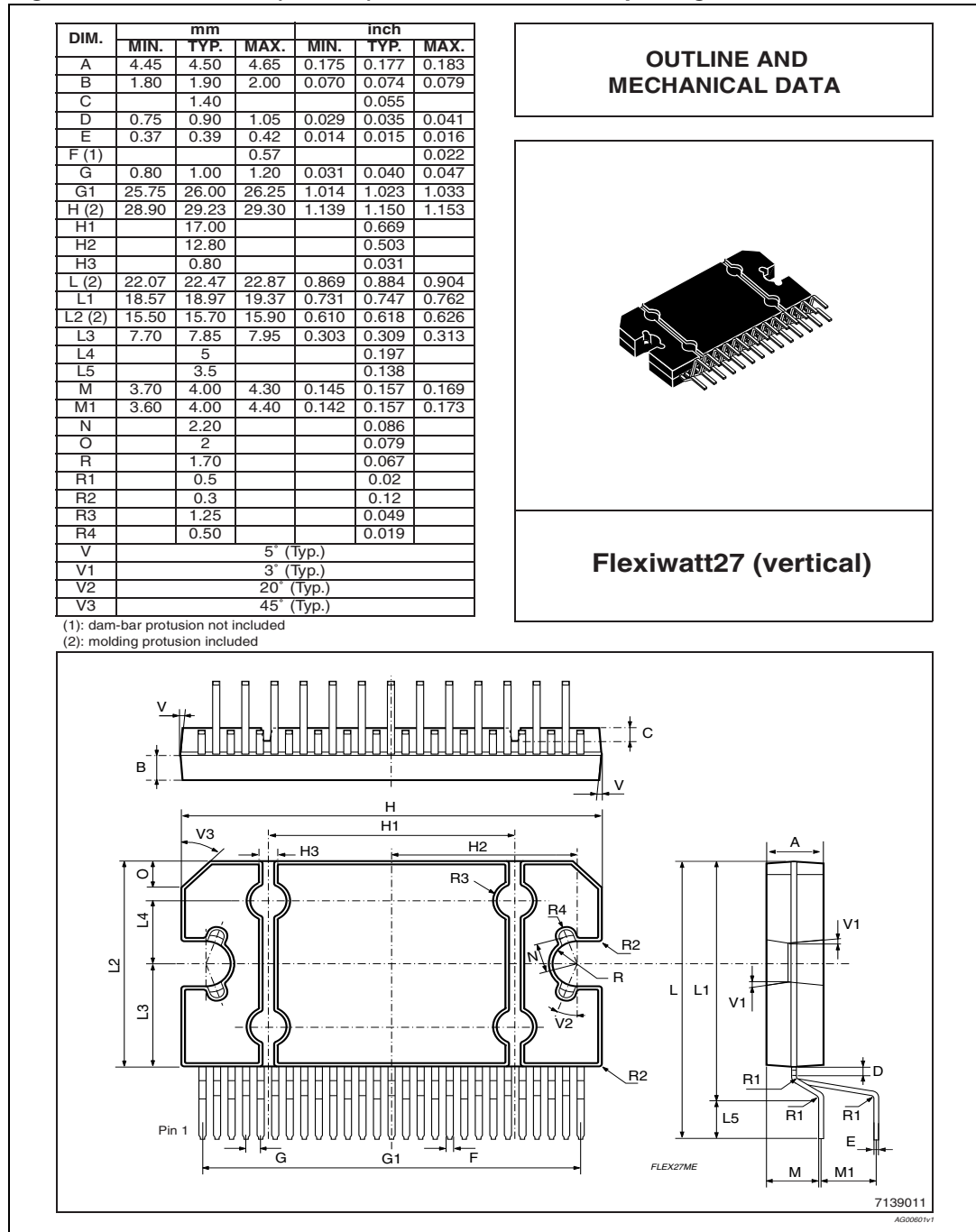

8 Revision history

Table 12. Document revision history

Date	Revision	Changes
20-Sep-2003	1	Initial release.
1-Jul-2008	2	Document reformatted. Document status promoted from product preview to datasheet.
25-Jan-2010	3	Updated <i>Features</i> and <i>Description on page 1</i> . Updated <i>Table 4: Electrical characteristics</i> . Added <i>Section 6: Low voltage "start-stop" operation</i> .
03-Feb-2010	4	Minor text changes.
16-Sep-2013	5	Updated Disclaimer.

Please Read Carefully:

Information in this document is provided solely in connection with ST products. STMicroelectronics NV and its subsidiaries ("ST") reserve the right to make changes, corrections, modifications or improvements, to this document, and the products and services described herein at any time, without notice.

All ST products are sold pursuant to ST's terms and conditions of sale.

Purchasers are solely responsible for the choice, selection and use of the ST products and services described herein, and ST assumes no liability whatsoever relating to the choice, selection or use of the ST products and services described herein.

No license, express or implied, by estoppel or otherwise, to any intellectual property rights is granted under this document. If any part of this document refers to any third party products or services it shall not be deemed a license grant by ST for the use of such third party products or services, or any intellectual property contained therein or considered as a warranty covering the use in any manner whatsoever of such third party products or services or any intellectual property contained therein.

UNLESS OTHERWISE SET FORTH IN ST'S TERMS AND CONDITIONS OF SALE ST DISCLAIMS ANY EXPRESS OR IMPLIED WARRANTY WITH RESPECT TO THE USE AND/OR SALE OF ST PRODUCTS INCLUDING WITHOUT LIMITATION IMPLIED WARRANTIES OF MERCHANTABILITY, FITNESS FOR A PARTICULAR PURPOSE (AND THEIR EQUIVALENTS UNDER THE LAWS OF ANY JURISDICTION), OR INFRINGEMENT OF ANY PATENT, COPYRIGHT OR OTHER INTELLECTUAL PROPERTY RIGHT.

ST PRODUCTS ARE NOT DESIGNED OR AUTHORIZED FOR USE IN: (A) SAFETY CRITICAL APPLICATIONS SUCH AS LIFE SUPPORTING, ACTIVE IMPLANTED DEVICES OR SYSTEMS WITH PRODUCT FUNCTIONAL SAFETY REQUIREMENTS; (B) AERONAUTIC APPLICATIONS; (C) AUTOMOTIVE APPLICATIONS OR ENVIRONMENTS, AND/OR (D) AEROSPACE APPLICATIONS OR ENVIRONMENTS. WHERE ST PRODUCTS ARE NOT DESIGNED FOR SUCH USE, THE PURCHASER SHALL USE PRODUCTS AT PURCHASER'S SOLE RISK, EVEN IF ST HAS BEEN INFORMED IN WRITING OF SUCH USAGE, UNLESS A PRODUCT IS EXPRESSLY DESIGNATED BY ST AS BEING INTENDED FOR "AUTOMOTIVE, AUTOMOTIVE SAFETY OR MEDICAL" INDUSTRY DOMAINS ACCORDING TO ST PRODUCT DESIGN SPECIFICATIONS. PRODUCTS FORMALLY ESCC, QML OR JAN QUALIFIED ARE DEEMED SUITABLE FOR USE IN AEROSPACE BY THE CORRESPONDING GOVERNMENTAL AGENCY.

Resale of ST products with provisions different from the statements and/or technical features set forth in this document shall immediately void any warranty granted by ST for the ST product or service described herein and shall not create or extend in any manner whatsoever, any liability of ST.

ST and the ST logo are trademarks or registered trademarks of ST in various countries.

Information in this document supersedes and replaces all information previously supplied.

The ST logo is a registered trademark of STMicroelectronics. All other names are the property of their respective owners.

© 2013 STMicroelectronics - All rights reserved

STMicroelectronics group of companies

Australia - Belgium - Brazil - Canada - China - Czech Republic - Finland - France - Germany - Hong Kong - India - Israel - Italy - Japan - Malaysia - Malta - Morocco - Philippines - Singapore - Spain - Sweden - Switzerland - United Kingdom - United States of America

www.st.com



Компания «ЭлектроПласт» предлагает заключение долгосрочных отношений при поставках импортных электронных компонентов на взаимовыгодных условиях!

Наши преимущества:

- Оперативные поставки широкого спектра электронных компонентов отечественного и импортного производства напрямую от производителей и с крупнейших мировых складов;
- Поставка более 17-ти миллионов наименований электронных компонентов;
- Поставка сложных, дефицитных, либо снятых с производства позиций;
- Оперативные сроки поставки под заказ (от 5 рабочих дней);
- Экспресс доставка в любую точку России;
- Техническая поддержка проекта, помощь в подборе аналогов, поставка прототипов;
- Система менеджмента качества сертифицирована по Международному стандарту ISO 9001;
- Лицензия ФСБ на осуществление работ с использованием сведений, составляющих государственную тайну;
- Поставка специализированных компонентов (Xilinx, Altera, Analog Devices, Intersil, Interpoint, Microsemi, Aeroflex, Peregrine, Syfer, Eurofarad, Texas Instrument, Miteq, Cobham, E2V, MA-COM, Hittite, Mini-Circuits, General Dynamics и др.);

Помимо этого, одним из направлений компании «ЭлектроПласт» является направление «Источники питания». Мы предлагаем Вам помощь Конструкторского отдела:

- Подбор оптимального решения, техническое обоснование при выборе компонента;
- Подбор аналогов;
- Консультации по применению компонента;
- Поставка образцов и прототипов;
- Техническая поддержка проекта;
- Защита от снятия компонента с производства.



Как с нами связаться

Телефон: 8 (812) 309 58 32 (многоканальный)

Факс: 8 (812) 320-02-42

Электронная почта: org@eplast1.ru

Адрес: 198099, г. Санкт-Петербург, ул. Калинина, дом 2, корпус 4, литера А.