

Features

- ◆ Compact U-bracket and enclosed power supplies
- ◆ Screw terminal block
- ◆ Very high efficiency up to 93 %
- ◆ No internal fan for 120 W & 240 W models.
- ◆ Universal input 90 – 264 VAC
- ◆ Adjustable output voltage
- ◆ EMI/EMC compliance with EN 61000-6-3 and EN 61000-6-1
- ◆ Compliance to EN 61000-3-2 (PFC)
- ◆ Short circuit and overvoltage protection
- ◆ 3-year product warranty



The TRACOPOWER TXH series is a family of power supplies in metal enclosure, designed for a wide range of cost critical applications. The very high efficiency of up to 93% admits of a compact design with free air convection cooling for the 120 and 240 Watt models. The units are equipped with screw terminal blocks and are easy to install in any equipment.

These power supplies have universal input and comply with European EMC standards and the Low Voltage Directive (LVD).

Models with Single Output

Order code	Output power max.	Output voltage nom.	Output current max.	Efficiency typ. at 230 VAC
TXH 120-112	120 Watt	12 VDC	10 A	90 %
TXH 120-124		24 VDC	5.0 A	91 %
TXH 120-148		48 VDC	2.5 A	92 %
TXH 240-112	240 Watt	12 VDC	20 A	90 %
TXH 240-124		24 VDC	10 A	92 %
TXH 240-148		48 VDC	5.0 A	93 %
TXH 360-112	360 Watt	12 VDC	30 A	89 %
TXH 360-124		24 VDC	15 A	91 %
TXH 360-148		48 VDC	7.5 A	93 %
TXH 480-112	480 Watt	12 VDC	40 A	88 %
TXH 480-124		24 VDC	20 A	90 %
TXH 480-136		36 VDC	13.33 A	92 %
TXH 480-148		48 VDC	10 A	91 %

Input Specifications

Input voltage	– nominal – AC range (universal input) – DC range	100 – 240 VAC 90 – 264 VAC 120 – 370 VDC
Input frequency		47 – 63 Hz
Earth leakage current (240 VAC / 63 Hz)		360 W models: 300 μ A max. other models: 500 μ A max.
Input current at full load	– at 115 VAC / 230 VAC	120 W models: 2.0 A typ. / 1.0 A typ. 240 W models: 3.0 A typ. / 1.5 A typ. 360 W models: 4.0 A typ. / 2.0 A typ. 480 W models: 5.5 A typ. / 3.0 A typ.
Recommended circuit breaker (characteristic C) or slow blow fuse		120 & 240 W models: 5 A 360 & 480 W models: 10 A

Output Specifications

Voltage set accuracy		± 2 % max.																									
Output voltage adjustment range		120 & 240 W models: fixed 360 & 480 W models: ± 10 % with internal potentiometer																									
Regulation	– Input variation – Load variation (0–100%)	1 % max. 1 % max.																									
Minimum load		not required																									
Ripple and noise (20 MHz bandwidth) [mVp-p] max.	Models:	<table border="1"> <thead> <tr> <th></th> <th>12 VDC</th> <th>24 VDC</th> <th>36 VDC</th> <th>48 VDC</th> </tr> </thead> <tbody> <tr> <td>120 W</td> <td>120</td> <td>240</td> <td>-</td> <td>480</td> </tr> <tr> <td>240 W</td> <td>120</td> <td>200</td> <td>-</td> <td>200</td> </tr> <tr> <td>360 W</td> <td>150</td> <td>200</td> <td>-</td> <td>200</td> </tr> <tr> <td>480 W</td> <td>100</td> <td>200</td> <td>200</td> <td>300</td> </tr> </tbody> </table>		12 VDC	24 VDC	36 VDC	48 VDC	120 W	120	240	-	480	240 W	120	200	-	200	360 W	150	200	-	200	480 W	100	200	200	300
	12 VDC	24 VDC	36 VDC	48 VDC																							
120 W	120	240	-	480																							
240 W	120	200	-	200																							
360 W	150	200	-	200																							
480 W	100	200	200	300																							
Hold-up time		10 ms min.																									
Current limitation		130 - 150 % foldback, auto recovery																									
Short circuit protection		indefinite, auto recovery																									
	360 & 480 W models: 120 & 240 W models:	auto recovery no auto recovery (power disconnect required)																									
Overvoltage protection by Zener diode		120 % of Vout typ.																									
	360 & 480 W models: 120 & 240 W models:	auto recovery no auto recovery (power disconnect required)																									
Overtemperature protection		for 360 & 480 W models only, auto recovery																									
Capacitive load, [μ F] max.	Models:	<table border="1"> <thead> <tr> <th></th> <th>12 VDC</th> <th>24 VDC</th> <th>36 VDC</th> <th>48 VDC</th> </tr> </thead> <tbody> <tr> <td>120 W</td> <td>23'000</td> <td>1ba</td> <td>-</td> <td>470</td> </tr> <tr> <td>240 W</td> <td>23'000</td> <td>1ba</td> <td>-</td> <td>470</td> </tr> <tr> <td>360 W</td> <td>85'000</td> <td>48'000</td> <td>-</td> <td>13'000</td> </tr> <tr> <td>480 W</td> <td>180'000</td> <td>75'000</td> <td>50'000</td> <td>25'000</td> </tr> </tbody> </table>		12 VDC	24 VDC	36 VDC	48 VDC	120 W	23'000	1ba	-	470	240 W	23'000	1ba	-	470	360 W	85'000	48'000	-	13'000	480 W	180'000	75'000	50'000	25'000
	12 VDC	24 VDC	36 VDC	48 VDC																							
120 W	23'000	1ba	-	470																							
240 W	23'000	1ba	-	470																							
360 W	85'000	48'000	-	13'000																							
480 W	180'000	75'000	50'000	25'000																							

General Specifications

Temperature ranges	– Operating – Storage (non operating)	480 W models: -20°C to $+70^{\circ}\text{C}$ other models: -10°C to $+70^{\circ}\text{C}$ -25°C to $+85^{\circ}\text{C}$
Derating		2.5 %/K above $+50^{\circ}\text{C}$ (-20°C to $+5^{\circ}\text{C}$ operation also requires a derating for THX 480-112 model: 2%/K below 5°C)
Temperature coefficient		0.03 %/K
Humidity (non condensing)		95 % rel max.

All specifications valid at nominal input voltage, full load and $+25^{\circ}\text{C}$ after warm-up time unless otherwise stated.

General Specifications

Switching frequency (pulse width modulation PWM)	120 & 240 W models: 100 kHz typ. 360 W models: 75 kHz typ. 480 W models: 62.5 kHz typ.
Isolation voltage (60 sec.)	<ul style="list-style-type: none"> – Input / Output 120 & 240 W models: 4'000 VAC 360 & 480 W models: 3'000 VAC – Input / Case 120 & 240 W models: 2'000 VAC 360 & 480 W models: 1'500 VAC – Output / Case 500 VAC
Reliability /calculated MTBF (MIL-HDBK-217F, at +25°C, ground benign)	<ul style="list-style-type: none"> 120 & 360 W models: >120'000 h 240 W models: >50'000 h 480 W models: >100'000 h
Electromagnetic compatibility (EMC), Emissions	<ul style="list-style-type: none"> – Conducted input RI suppression EN 55022, class B, FCC part 15, level B – Harmonic current emissions IEC/EN 61000-3-2 class B
Electromagnetic compatibility (EMC), Immunity	EN 55024
Degree of protection	class I
Safety standards	UL 60950-1, IEC/EN 60950-1
Safety approvals	<ul style="list-style-type: none"> – UL/cUL 60950-1 www.ul.com -> certifications -> File e188913 – CB report according to IEC 60950-1 www.tracopower.com/products/txh-cb.pdf
Environment	<ul style="list-style-type: none"> – Vibration 3 axes, sine sweep, 10–500Hz, 2g, 0.1 oct/min – Shock tba.
Environmental compliance	<ul style="list-style-type: none"> – Reach www.tracopower.com/products/txh-reach.pdf – RoHS RoHS directive 2011/65/EU
Altitude during operation	<ul style="list-style-type: none"> 120 / 240 & 360 W models: up to 4'000 m (13'120 ft) approved 480 W models: up to 3'000 m (9'840 ft) approved

Outline Dimensions

TXH 120 models

Weight: 390 g (13.8 oz)

Optional Cover

TXH 120-COV	Cover incl. screws for TXH 120 models
--------------------	---------------------------------------

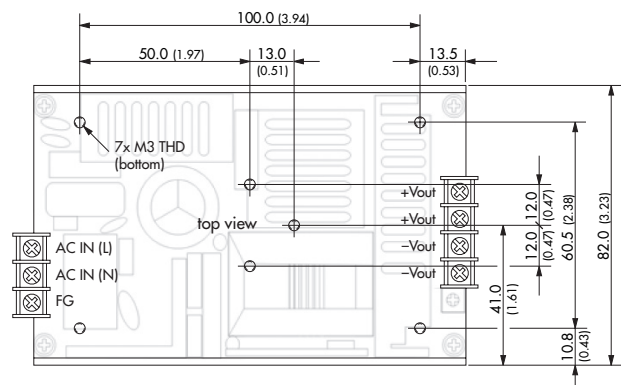
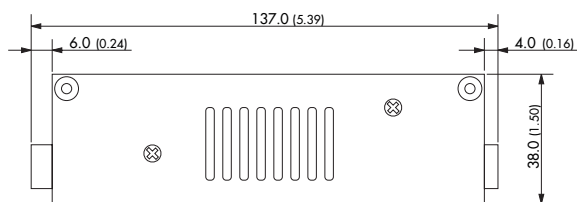

Outline Dimensions

TXH 240 models

Weight: 580 g (20.5 oz)

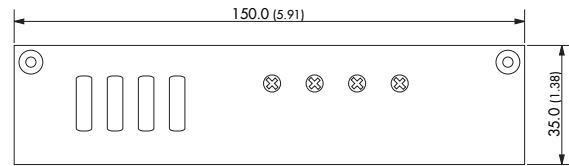

Optional Cover

TXH 240-COV Cover incl. screws for TXH 240 models

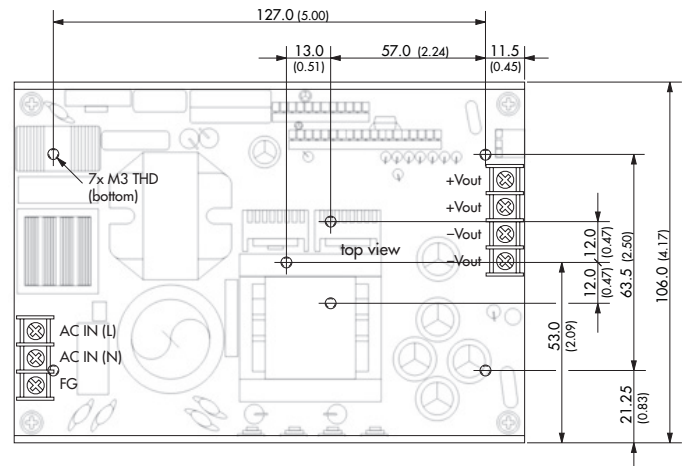

TXH 360 models

Weight: 750 g (26 oz)

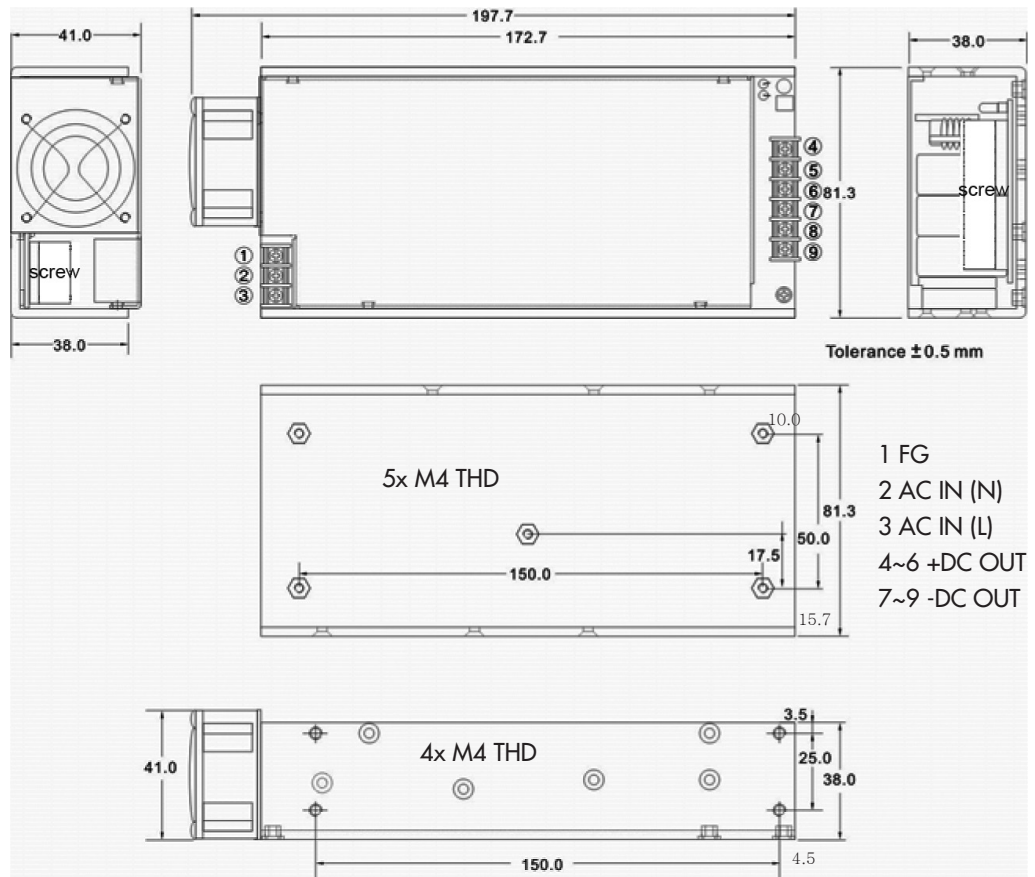

Max mounting screw penetration: 3.0 mm (0.12)

Dimensions in [mm], () = Inch
Tolerances ± 0.8 (± 0.03)
Mounting hole pitch tolerances ± 0.5 (± 0.02)

Outline Dimensions

TXH 480 models

Control connector	
C1	+ Sense
C2	- Sense
C3	Remote Control: open = On, short = Off
C4	
C5	DC-OK: 4-6 VDC = On, 0-1 VDC = Off
C6	GND
C7	+5 VDC aux. ±10%, 0.6 A max.
C8	GND aux.

Input terminal	
1	AC (N)
2	AC (L)
3	FG

Output terminal	
4-6	+ Vout
7-9	- Vout

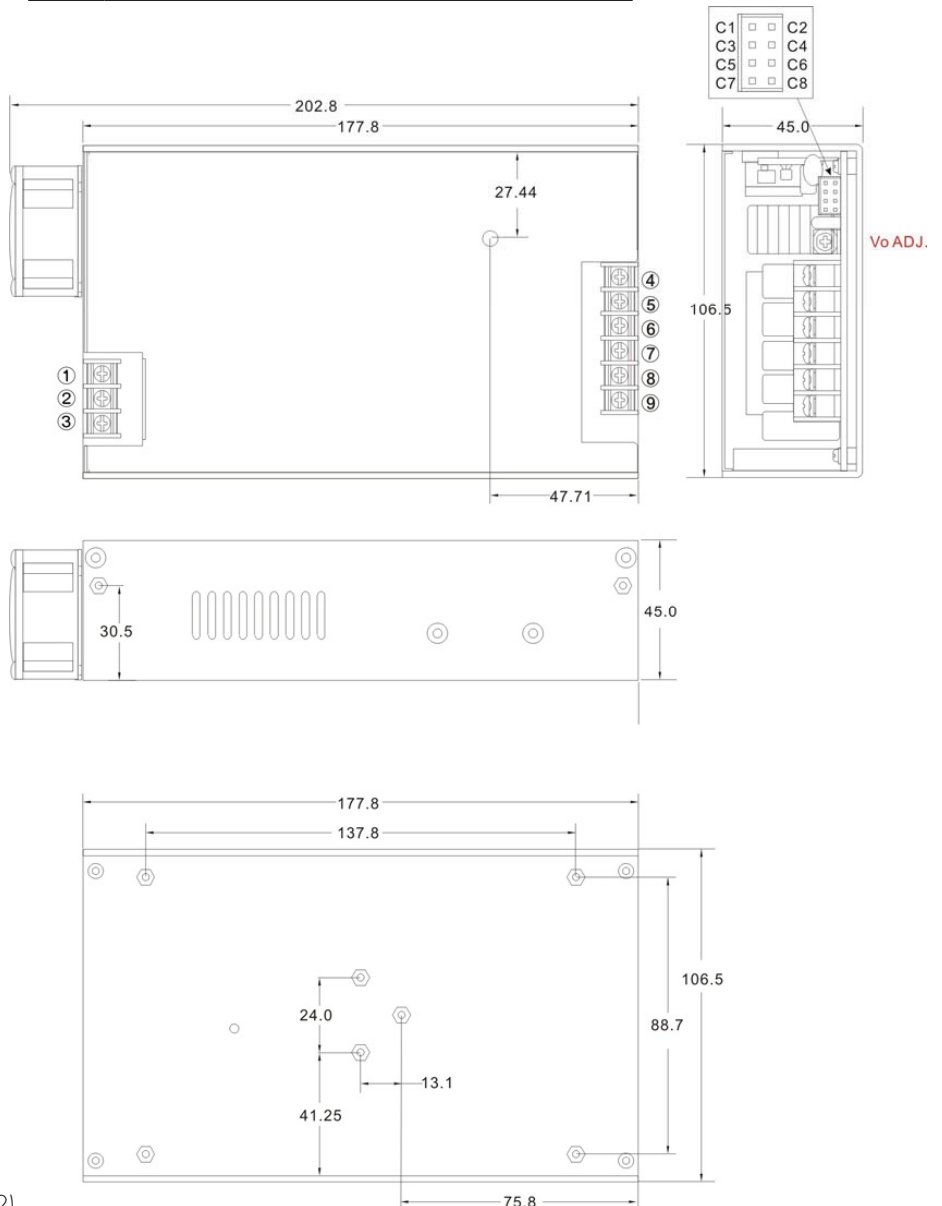

Weight: 1050 g (37 oz)

Dimensions in [mm], () = Inch
Tolerances ±0.8 (±0.03)
Mounting hole pitch tolerances ±0.5 (±0.02)

Max mounting screw penetration: 2.5 mm (0.10)

Specifications can be changed without notice! Make sure you are using the latest documentation, downloadable at www.tracopower.com



Компания «ЭлектроПласт» предлагает заключение долгосрочных отношений при поставках импортных электронных компонентов на взаимовыгодных условиях!

Наши преимущества:

- Оперативные поставки широкого спектра электронных компонентов отечественного и импортного производства напрямую от производителей и с крупнейших мировых складов;
- Поставка более 17-ти миллионов наименований электронных компонентов;
- Поставка сложных, дефицитных, либо снятых с производства позиций;
- Оперативные сроки поставки под заказ (от 5 рабочих дней);
- Экспресс доставка в любую точку России;
- Техническая поддержка проекта, помощь в подборе аналогов, поставка прототипов;
- Система менеджмента качества сертифицирована по Международному стандарту ISO 9001;
- Лицензия ФСБ на осуществление работ с использованием сведений, составляющих государственную тайну;
- Поставка специализированных компонентов (Xilinx, Altera, Analog Devices, Intersil, Interpoint, Microsemi, Aeroflex, Peregrine, Syfer, Eurofarad, Texas Instrument, Miteq, Cobham, E2V, MA-COM, Hittite, Mini-Circuits, General Dynamics и др.);

Помимо этого, одним из направлений компании «ЭлектроПласт» является направление «Источники питания». Мы предлагаем Вам помощь Конструкторского отдела:

- Подбор оптимального решения, техническое обоснование при выборе компонента;
- Подбор аналогов;
- Консультации по применению компонента;
- Поставка образцов и прототипов;
- Техническая поддержка проекта;
- Защита от снятия компонента с производства.



Как с нами связаться

Телефон: 8 (812) 309 58 32 (многоканальный)

Факс: 8 (812) 320-02-42

Электронная почта: org@eplast1.ru

Адрес: 198099, г. Санкт-Петербург, ул. Калинина, дом 2, корпус 4, литера А.