



# IGAR-2062+-4G

## Industrial IEEE 802.11 a/b/g/n Dual 4G LTE Cellular Router with 2x10/100/1000Base-T(X)

### Features

- High Speed Air Connectivity: WLAN interface support up to 300Mbps link speed
- Provide 2 port 10/100/1000Base-T(X) port and 2 sim card slot
- **Support dual 4G LTE dial up backup and load balance.**
- Provide HNAT enhance LAN to WAN routing performance
- Highly Security Capability: WEP/WPA/WPA-PSK(TKIP,AES)/WPA2/WPA2-PSK(TKIP,AES)/802.1X Authentication supported
- Secured Management by HTTPs
- Support STP(802.1D) for wireless redundancy
- Various kind of WAN Connection Type supported: Dynamic/Static IP, PPPoE, Modem/Dial Up
- IP table to prevent access from unauthorized IP address
- Support VPN for secured network connection (Open VPN , PPTP VPN, IPSEC VPN)
- Support NAT Setting (Virtual Server , Port Trigger , DMZ , UPnP)
- 3G Modem signal information display (un-connecting status)
- Wireless connecting status monitoring
- Versatile modes & event alarm by e-mail
- 1KV isolation for PoE P.D. port
- Event Warning by Syslog, Email, SNMP Trap, Relay and Beeper
- Rigid IP-30 housing design
- DIN-Rail and Wall-mount enabled



### Introduction

IGAR-2062+-4G is a reliable IEEE 802.11 a/b/g/n WLAN VPN router with 2 ports 10/100/1000Base-T(X) router where ETH1 for LAN and ETH2 for WAN. It supports 802.1X and MAC filter for security control. It could be configured to operate in 3 modes of routing function: Dynamic/Static IP route, PPPoE authentication, and Modem dial up. In the mode of Modem dial up, it support GPRS/3G/3.5G/LTE modem by internal cellular module. Users can set up WLAN environment to fulfill demands of various applications rapidly by dual SIM dialing up cellular modems. In addition, IGAR-2062+-4G also provides P.D. feature on ETH2 which is fully compliant with IEEE802.3af PoE P.D. specification. This feature extends the layout up to 100 meters. Therefore, IGAR-2062+-4G is one of the best solution for applications of wireless communication.

## Application

In IGAR-2062+-4G, there are 3 modes of routing functions supported: Dynamic/Static IP route, PPPoE dial up, and Modem dial up. IGAR-2062+-4G also support NAT, VPN and Back up functions. You can build up the wireless network and connect to the Internet easily.

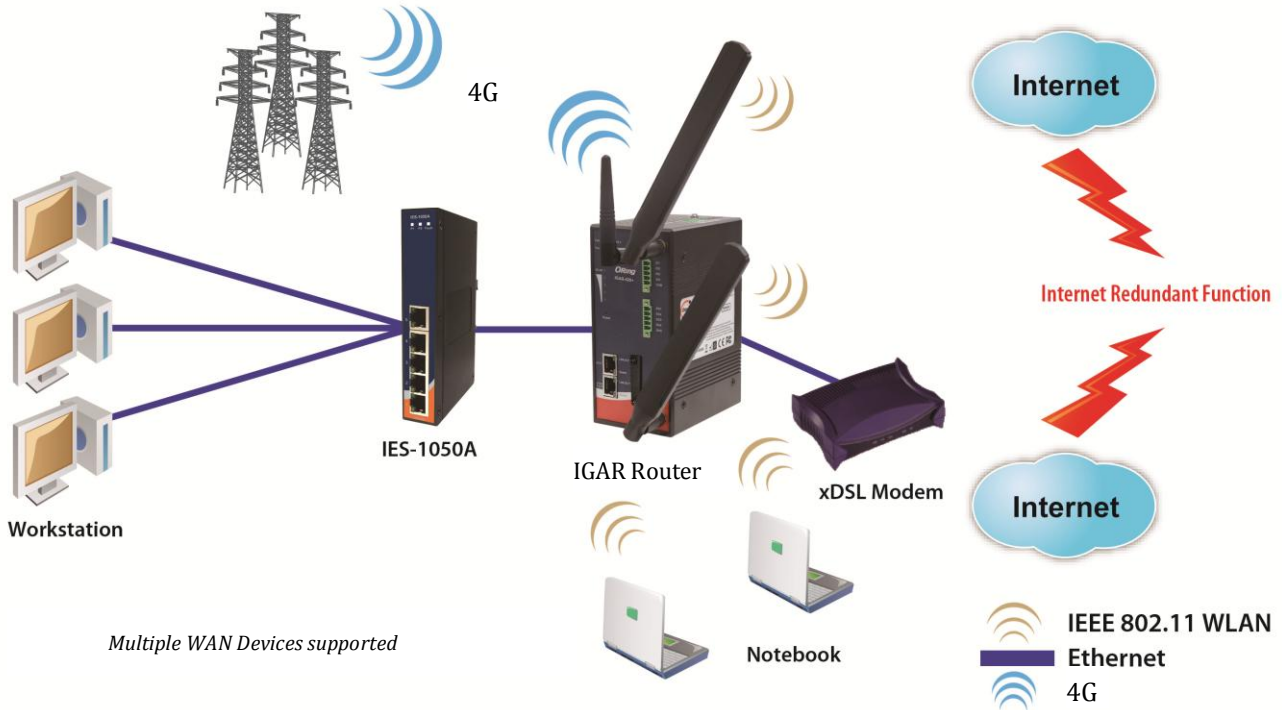

## Dimension

Dimension (Unit =mm)

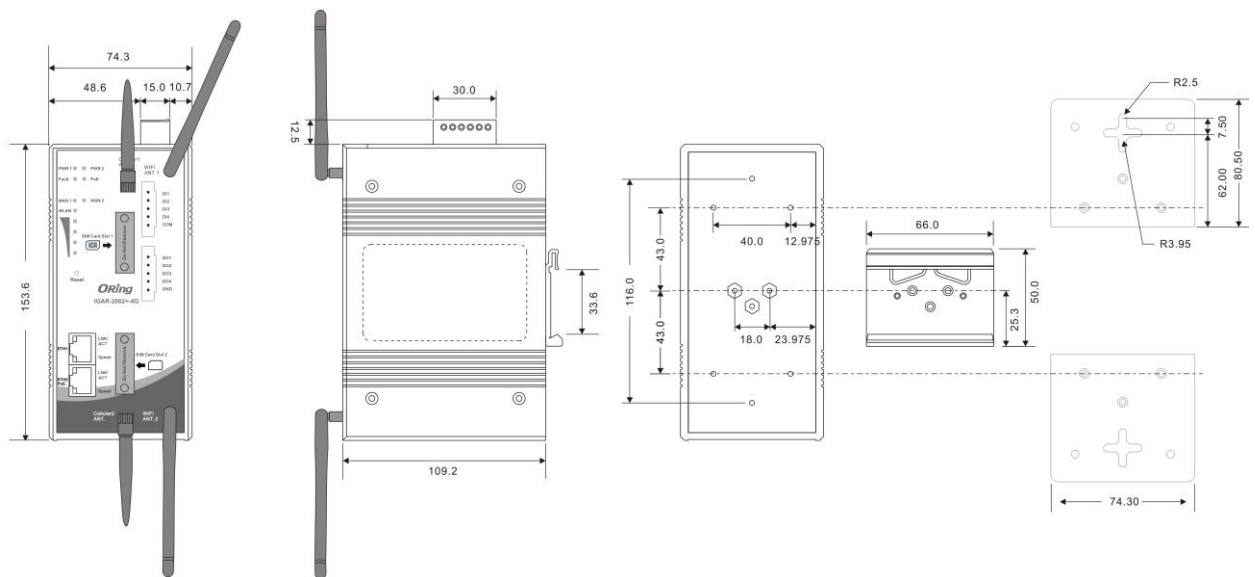

## DI/DO Definition

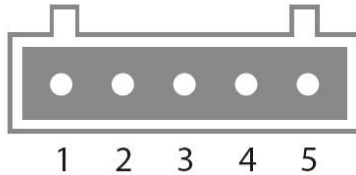

### Digital Input Pin Definition

PIN	1	2	3	4	5
Function	DI1	DI2	DI3	DI4	COM

### Digital Output Pin Definition

PIN	1	2	3	4	5
Function	DO1	DO2	DO3	DO4	GND

## Specifications

ORing AP Router Model	IGAR-2062+-4G
<b>Physical Ports</b>	
10/100/1000 Base-T(X) Ports in RJ45 Auto MDI/MDIX	2
PoE P.D. port	Present at ETH2 Fully compliant with IEEE 802.3af Power Device specification Over load & short circuit protection Isolation Voltage: 1000 VDC min. Isolation Resistance : 10 <sup>8</sup> ohms min
5-Pin Terminal Block	2(DI x 4 and DO x 4)
Sim Card Slot	2
<b>Cellular Interface</b>	
Antenna Connector	2 x SMA Female
Cellular Standard	GSM / GPRS/ EGPRS/ EDGE / WCDMA / HSDPA / HSUPA /HSPA+ /LTE
Band Option	<b>America(US)</b> LTE: 700/1700/2100/ MHz UMTS/HSDPA/HSUPA/HSPA+/DC-HSPA+: 800/850/1900/2100 MHz GSM/GPRS/EDGE: 850/900/1800/1900 MHz <b>Europe(EU)</b> LTE:

	800/900/1800/2100/2600 MHz UMTS/HSDPA/HSUPA/HSPA+/DC-HSPA+: 900/2100 MHz GSM/GPRS/EDGE: 900/1800/1900 MHz
<b>WLAN interface</b>	
Antenna Connector	2 x Reverse SMA Female
Modulation	IEEE802.11b: CCK/DQPSK/DBPSK IEEE802.11a/g: OFDM IEEE802.11n: BPSK, QPSK, 16-QAM, 64-QAM
Frequency Band	America / FCC: 2.412~2.462 GHz (11 channels ) 5.180~5.240 GHz & 5.745~5.825 GHz ( 9 channels ) Europe CE / ETSI: 2.412~2.472 GHz ( 13 channels ) 5.180~5.240 GHz ( 4 channels )
Transmission Rate	802.11b: 1/2/5.5/11 Mbps 802.11a/g: 6/9/12/18/24/36/48/54 Mbps 802.11n(40MHz): UP to 300 Mbps
Transmit Power	802.11a: 12dBm ± 1.5dBm@54Mbps 802.11b: 17dBm ± 1.5dBm@11Mbps 802.11g: 16dBm ± 1.5dBm@54Mbps 802.11gn HT20: 15dBm ± 1.5dBm @MCS7 802.11gn HT40: 14dBm ± 1.5dBm @MCS7 802.11an HT20: 12dBm ± 1.5dBm @MCS7 802.11an HT40: 11dBm ± 1.5dBm @MCS7
Receiver Sensitivity	802.11a : -76dBm ± 2dBm@54Mbps 802.11b : -85dBm ± 2dBm@11Mbps 802.11g : -76dBm ± 2dBm@54Mbps 802.11gn HT20:-75dBm ± 2dBm@MCS7 802.11gn HT40:-72dBm ± 2dBm@MCS7 802.11an HT20:-74dBm ± 2dBm@MCS7 802.11an HT40:-71dBm ± 2dBm@MCS7
Encryption Security	WEP: (64-bit ,128-bit key supported) WPA/WPA2 :802.11i(WEP and AES encryption) WPA-PSK (256-bit key pre-shared key supported) 802.1X Authentication supported TKIP encryption
Wireless Security	SSID broadcast disable
<b>LED indicators</b>	
Power indicator	3 x LEDs, PWR1(2)(PoE) / Ready: Red On : Power is on and booting up Green On : Power is on and functioning Normal
10/100/1000TX RJ45 port indicator	2 x LEDs, LNK/ACT:Green for port Act. Speed: Green for port Link at 1000Mbps Amber for port Link at 100Mbps. Off for port Link at 10Mbps
WLAN LEDs:	Green Solid On: RF on, Blink: data transmitting Green for WLAN Strength: 1<25%, 2<50%, 3<75%, 4<100%
WAN LEDs:	2 x LEDs, Green On : Power is on and functioning Normal
Fault	1 x LED, Red for Ethernet link down or power down indicator
<b>Fault contact</b>	
Relay	Relay output to carry capacity of 1A at 24VDC
<b>Power</b>	
Redundant Input power	Dual DC inputs. 12-48VDC on 6-pin terminal block
Power consumption	<15 Watts
Overload current protection	Present
Reverse polarity protection	Present
<b>Physical Characteristic</b>	
Enclosure	IP-30
Dimension (W x D x H)	74.3(W) x 109.2(D) x 153.6(H) mm (2.93 x 4.3 x 6.05 inch.)

Weight (g)	1155g
<b>Environmental</b>	
Storage Temperature	-40 to 85°C (-40 to 185°F)
Operating Temperature	-25 to 70°C (-13 to 158°F)
Operating Humidity	5% to 95% Non-condensing
<b>Regulatory approvals</b>	
EMI	FCC Part 15, CISPR (EN55022) class A
EMS	EN61000-4-2 (ESD), EN61000-4-3 (RS), EN61000-4-4 (EFT), EN61000-4-5 (Surge), EN61000-4-6 (CS), EN61000-4-8, EN61000-4-11
Shock	IEC60068-2-27
Free Fall	IEC60068-2-32
Vibration	IEC60068-2-6
Safety	EN60950-1
<b>Warranty</b>	5 years

## Ordering Information

**IGAR-ABCDE FF**

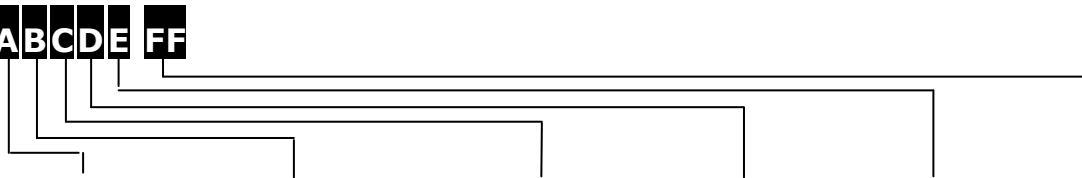

Code Definition	Cellular Module Number	2 <sup>nd</sup> Wireless Mode	1 <sup>st</sup> Wireless Mode	Giga Ethernet Port Number	PoE Identification	Cellular Generation
Option	1: One SIM 2: Dual SIM	1: 802.11 b/g 2: 802.11 a 3: 802.11 a/b/g 4: 802.11 b/g/n 5: 802.11 a/n 6: 802.11 a/b/g/n	1: 802.11 b/g 2: 802.11 a 3: 802.11 a/b/g 4: 802.11 b/g/n 5: 802.11 a/n 6: 802.11 a/b/g/n	2: 2 ports	+ : PoE P.D. present at ETH2	4G :LTE

	Model Name	Description
Available Model	<b>IGAR-2062+-4G_US</b>	Industrial IEEE 802.11 a/b/g/n Dual 4G LTE Cellular router with 2x10/100/1000Base-T(X), 1-port PoE P.D., US band
	<b>IGAR-2062+-4G_EU</b>	Industrial IEEE 802.11 a/b/g/n Dual 4G LTE 3G Cellular router with 2x10/100/1000Base-T(X), 1-port PoE P.D., EU band

## Packing List

<b>IGAR-2062+-4G</b>	<b>CD x 1</b>	<b>Quick Installation Guide x 1</b>
<b>2.5GHz/5GHz Antenna x 2</b>	<b>Din-Rail Kit x 1</b>	<b>Wall-Mount Kit x 2</b>
<b>LTE Antenna x 2</b>	<b>5-Pin Terminal Block x 2</b>	<b>Dust Cover x 2</b>
<b>6-Pin Terminal Block x 1</b>		

## Optional Accessories

**DR-45 series : 45 Watts power supply**

**DR-120 series : 120 Watts power supply**

**RF Antenna Base (Magnetic) series**

**DR-75 series : 75 Watts power supply**

**WLAN RF Antenna (Omni-directional) series**

**RF Cable series**



Компания «ЭлектроПласт» предлагает заключение долгосрочных отношений при поставках импортных электронных компонентов на взаимовыгодных условиях!

Наши преимущества:

- Оперативные поставки широкого спектра электронных компонентов отечественного и импортного производства напрямую от производителей и с крупнейших мировых складов;
- Поставка более 17-ти миллионов наименований электронных компонентов;
- Поставка сложных, дефицитных, либо снятых с производства позиций;
- Оперативные сроки поставки под заказ (от 5 рабочих дней);
- Экспресс доставка в любую точку России;
- Техническая поддержка проекта, помощь в подборе аналогов, поставка прототипов;
- Система менеджмента качества сертифицирована по Международному стандарту ISO 9001;
- Лицензия ФСБ на осуществление работ с использованием сведений, составляющих государственную тайну;
- Поставка специализированных компонентов (Xilinx, Altera, Analog Devices, Intersil, Interpoint, Microsemi, Aeroflex, Peregrine, Syfer, Eurofarad, Texas Instrument, Miteq, Cobham, E2V, MA-COM, Hittite, Mini-Circuits, General Dynamics и др.);

Помимо этого, одним из направлений компании «ЭлектроПласт» является направление «Источники питания». Мы предлагаем Вам помощь Конструкторского отдела:

- Подбор оптимального решения, техническое обоснование при выборе компонента;
- Подбор аналогов;
- Консультации по применению компонента;
- Поставка образцов и прототипов;
- Техническая поддержка проекта;
- Защита от снятия компонента с производства.



#### Как с нами связаться

**Телефон:** 8 (812) 309 58 32 (многоканальный)

**Факс:** 8 (812) 320-02-42

**Электронная почта:** [org@eplast1.ru](mailto:org@eplast1.ru)

**Адрес:** 198099, г. Санкт-Петербург, ул. Калинина, дом 2, корпус 4, литера А.