

WHITE-RODGERS DC PRODUCTS

Type 70 and 71 contactors

FEATURES

- High current capacity control
- Isolated or grounded coils
- Enclosed in dust-resistant case
- Longer steel encasement permits lower heat rise and more sensitive operation on Type 71

ENGINEERING DATA

Contacts

- Pole form– SPNO, SPDT
- Material– SPNO-copper or silver
SPDT-copper and silver or all silver
- Termination– $\frac{5}{16}$ "-24 UNF-2A thread

RATINGS					
Type	Volts DC	NO		NC	
		Cont.	Inrush	Cont.	Inrush
70	6	80A	300 A	60A	100 A
	12	80 A	150 A	60 A	60 A
	24 & 36	50 A	50 A	30 A	30 A
71	6	80A	300 A	60A	100 A
	12	80 A	150 A	60 A	60 A
	24 & 36	50 A	50 A	30 A	30 A

Coils

- Voltage–6 VDC through 36 VDC
- Termination–#10-32 UNF-2A thread
- Power (approximate)
Type 70 intermittent 23 watts
Type 70 continuous 9 watts
Type 71 intermittent 25 watts
Type 71 continuous 10 watts
- Connections
 1. Two coil terminals isolated from case
 2. One coil terminal with ground wire, one coil terminal isolated from case
 3. One coil lead common to NO terminal marked "BAT" (one terminal)
- Operate (77°F/25°C)
75% of nominal coil voltage; 110% max. safe of nominal coil voltage



GENERAL DATA

- Dielectric Strength
 - 500 Volts
- Temperature Range
 - -40°F/-40°C to 122°F/50°C
- Mechanical Life (no load)
 - 250,000 operations
- Electrical Life (rated load)
 - 100,000 operations
- Mounting Position
 - Recommended mounting with cap down
- Vibration
 - 5 g's vertical and horizontal planes
- Weight (approximate)
 - Type 70–14.0 oz.
 - Type 71–17.0 oz.
- Duty Cycle
 - Continuous
 - Intermittent–10 seconds "on" maximum and minimum 60 seconds "off". One minute "on" maximum and minimum 6 minutes "off".
- Hardware Torque Specification
 - Contact Terminal: 45-55 inch-lbs.
 - Coil Terminal: 12-18 inch-lbs.
 - Mounting Bracket: 100 inch-lbs. max (a backup wrench must be used to hold the bottom nut stationary during installation)

COIL DATA					
TYPE 70			TYPE 71		
Volts DC	Resistance (Ohms)		Volts DC	Resistance (Ohms)	
	Int.	Cont.		Int.	Cont.
6	1.5	4.0	6	1.4	3.5
12	6.2	16.0	12	4.9	13.5
18	16.0	37.4	18	13.46	36.0
24	23.9	60.4	24	20.1	57.1
36	60.4	114.0	36	57.1	131.0

TYPE 70/71 PART NUMBERING SYSTEM

7x - xxxxx - x

Basic Part Number Series
Type 71 case is approx. 0.29" longer than Type 70

Contact Form
1 - SPNO
3 - SPDT

Coil Voltage/Duty
08 - 6 Volt continuous
09 - 6 Volt intermittent
11 - 12 Volt continuous
12 - 12 Volt intermittent
14 - 18 Volt continuous
15 - 18 Volt intermittent
17 - 24 Volt continuous
18 - 24 Volt intermittent
20 - 36 Volt continuous
21 - 36 Volt intermittent

Coil Termination
(15 in-lb torque spec.)
221 - Isolated coil, all Ag contacts
222 - Coil terminal with ground wire, all Ag contacts
224 - Isolated coil, Cu NO and Ag NC contacts
225 - Coil terminal with ground wire, Cu NO and Ag NC contacts
226 - Coil common to NO (stud marked "BAT"), Cu NO and Ag NC contacts

Factory Assigned Specials
(where undefined, contact factory)
2 - Hardware loosely assembled
2B - Customer requested markings
2C - Customer requested markings
3 - Customer requested markings
4 - Customer requested markings
5 - Hardware bulk packed
5C - Customer requested markings
5F - Customer requested markings
7 - No hardware included

Not all part number combinations are released. Please contact your Sales Representative for a list of active part numbers.

APPLICATION NOTES

- A back-up wrench **MUST** be used to hold the bottom nut stationary during installation.
- Solenoids applied in battery charging circuits should be protected from higher than rated voltage during charging. The service life may be affected by this condition and the solenoid may or may not operate the circuit as intended.
- Circuits should be designed to provide safe operation should the solenoid fail in either the open or closed position.
- Special construction options, including a curved bracket, may be available under other part numbers, including 111-xxxD (short can), 111-xxxE (long can), 5608-x and 878x-x.

SPNO - Isolated Coil

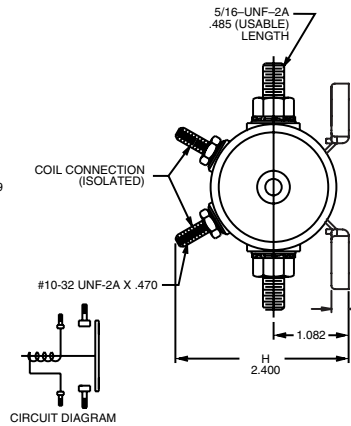
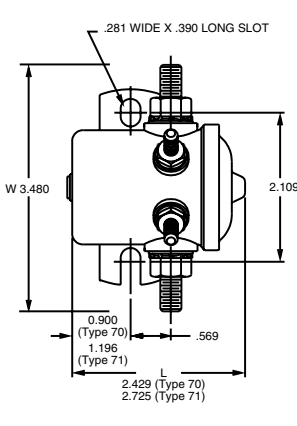

Coil Terminal to Ground

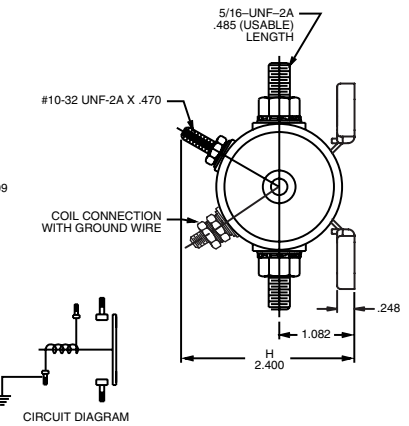
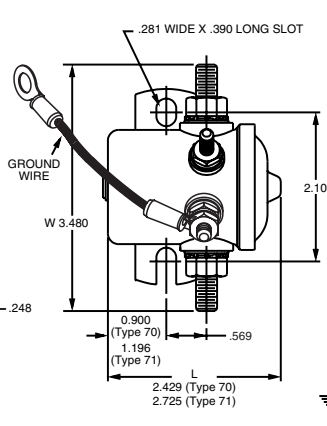

Coil Common to Load

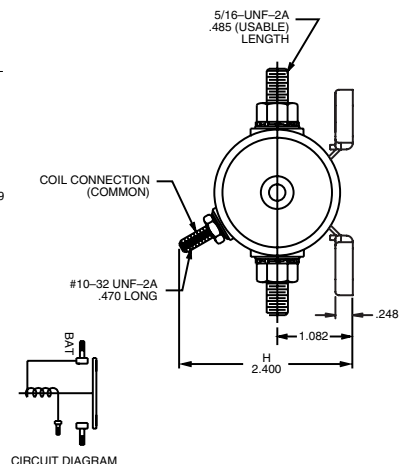
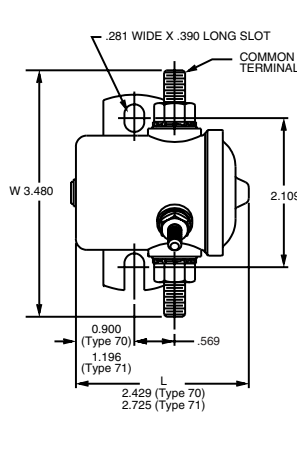

SPDT - Isolated Coil

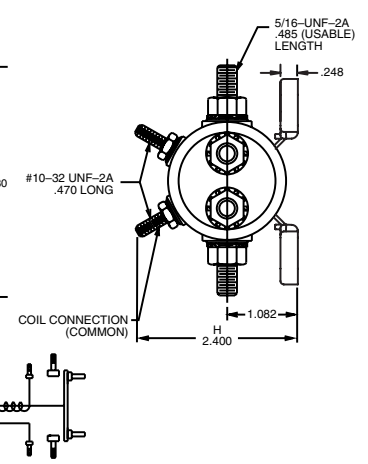
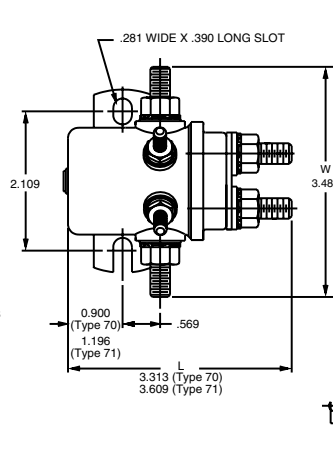



Компания «ЭлектроПласт» предлагает заключение долгосрочных отношений при поставках импортных электронных компонентов на взаимовыгодных условиях!

Наши преимущества:

- Оперативные поставки широкого спектра электронных компонентов отечественного и импортного производства напрямую от производителей и с крупнейших мировых складов;
- Поставка более 17-ти миллионов наименований электронных компонентов;
- Поставка сложных, дефицитных, либо снятых с производства позиций;
- Оперативные сроки поставки под заказ (от 5 рабочих дней);
- Экспресс доставка в любую точку России;
- Техническая поддержка проекта, помощь в подборе аналогов, поставка прототипов;
- Система менеджмента качества сертифицирована по Международному стандарту ISO 9001;
- Лицензия ФСБ на осуществление работ с использованием сведений, составляющих государственную тайну;
- Поставка специализированных компонентов (Xilinx, Altera, Analog Devices, Intersil, Interpoint, Microsemi, Aeroflex, Peregrine, Syfer, Eurofarad, Texas Instrument, Miteq, Cobham, E2V, MA-COM, Hittite, Mini-Circuits, General Dynamics и др.);

Помимо этого, одним из направлений компании «ЭлектроПласт» является направление «Источники питания». Мы предлагаем Вам помощь Конструкторского отдела:

- Подбор оптимального решения, техническое обоснование при выборе компонента;
- Подбор аналогов;
- Консультации по применению компонента;
- Поставка образцов и прототипов;
- Техническая поддержка проекта;
- Защита от снятия компонента с производства.



Как с нами связаться

Телефон: 8 (812) 309 58 32 (многоканальный)

Факс: 8 (812) 320-02-42

Электронная почта: org@eplast1.ru

Адрес: 198099, г. Санкт-Петербург, ул. Калинина, дом 2, корпус 4, литера А.